



US 20070296902A1

(19) **United States**

(12) **Patent Application Publication**
LEE et al.

(10) **Pub. No.: US 2007/0296902 A1**

(43) **Pub. Date: Dec. 27, 2007**

(54) **FFS MODE LIQUID CRYSTAL DISPLAY**

(30) **Foreign Application Priority Data**

Aug. 26, 2003 (KR)..... 10-2003-0059242

(76) Inventors: **Kyung Ha LEE**, Kyoungki-do (KR);
Hyang Yul KIM, Kyoungki-do (KR);
Jong Yob JEON, Kyoungki-do (KR);
Chi Wook AN, Kyoungki-do (KR)

Publication Classification

(51) **Int. Cl.**
G02F 1/1343 (2006.01)

(52) **U.S. Cl.** **349/141**

Correspondence Address:
LADAS & PARRY LLP
224 SOUTH MICHIGAN AVENUE
SUITE 1600
CHICAGO, IL 60604 (US)

(57) **ABSTRACT**

An FFS (Fringe Field Switching) mode liquid crystal display comprises a lower substrate and an upper substrate and a gate line formed on the lower substrate. A data line crosses perpendicular to the gate line. A first ITO electrode is formed in a region defined by the gate line and the data line. A second ITO electrode of a comb-teeth pattern is formed on the lower substrate while being overlapped on the first ITO electrode. A black matrix formed on the upper substrate, wherein, a wedge portion of the second ITO electrode is formed at a position spaced by a predetermined interval to the inside from an edge section of the black matrix.

(21) Appl. No.: **11/853,125**

(22) Filed: **Sep. 11, 2007**

Related U.S. Application Data

(63) Continuation of application No. 10/883,422, filed on Jun. 30, 2004, now abandoned.

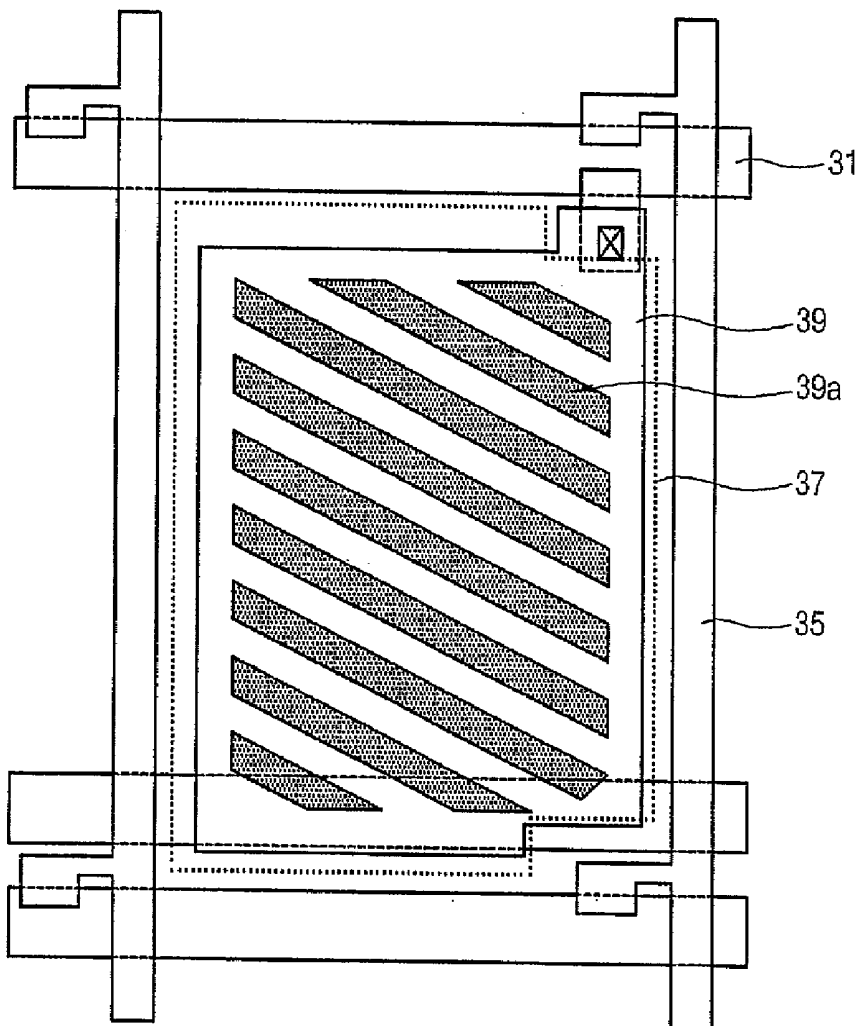

FIG. 1A

(PRIOR ART)

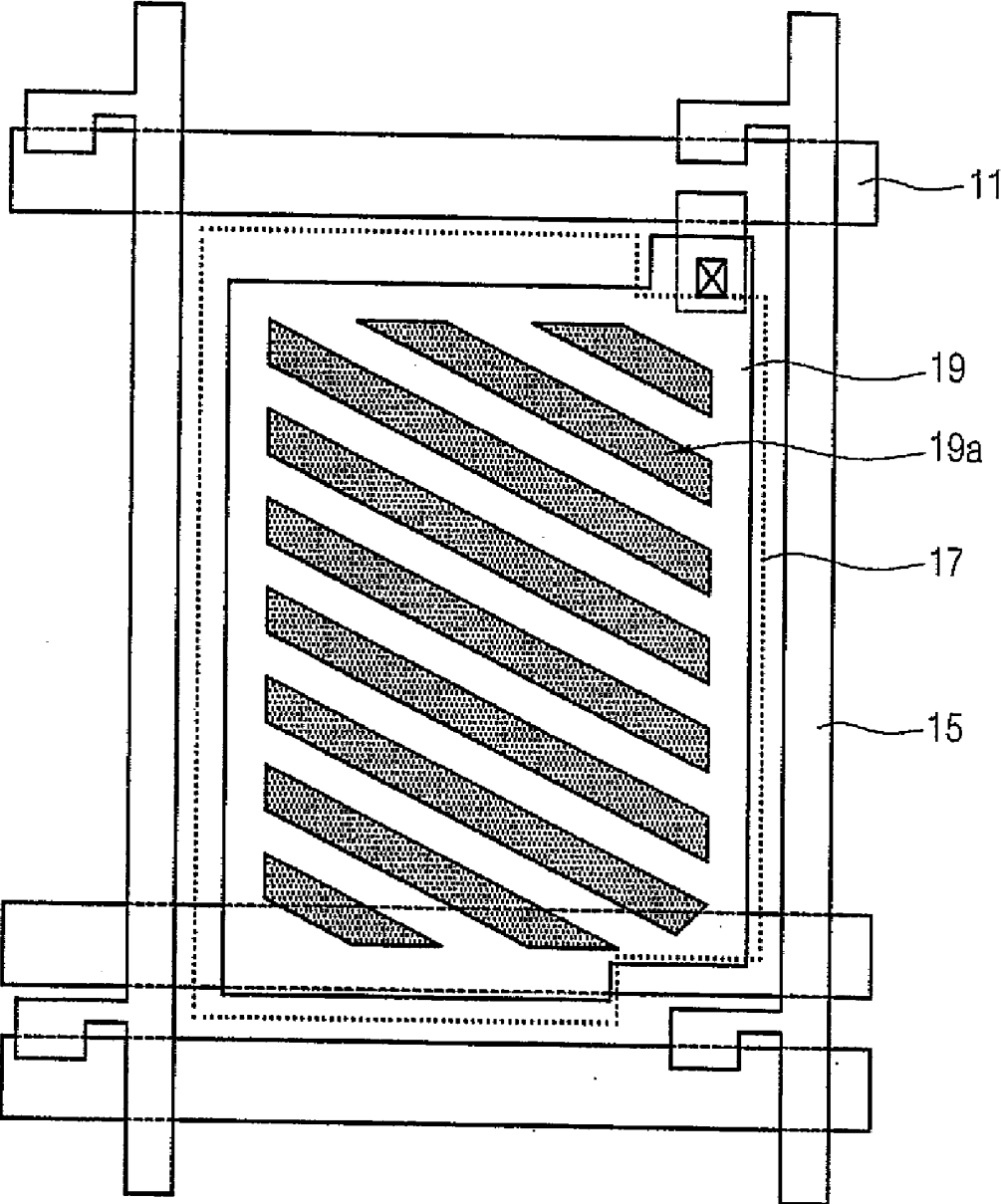

FIG. 1B

(PRIOR ART)

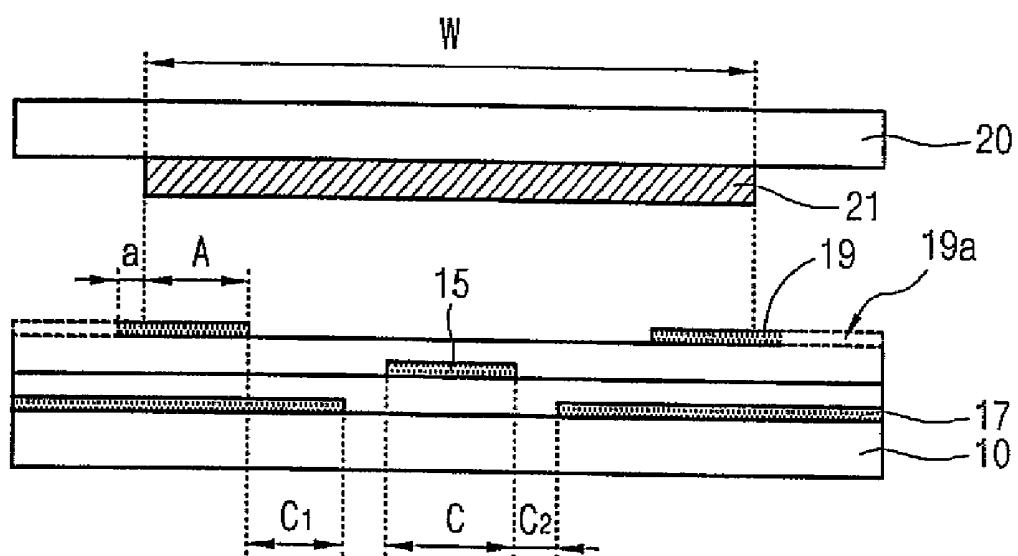

FIG. 2A

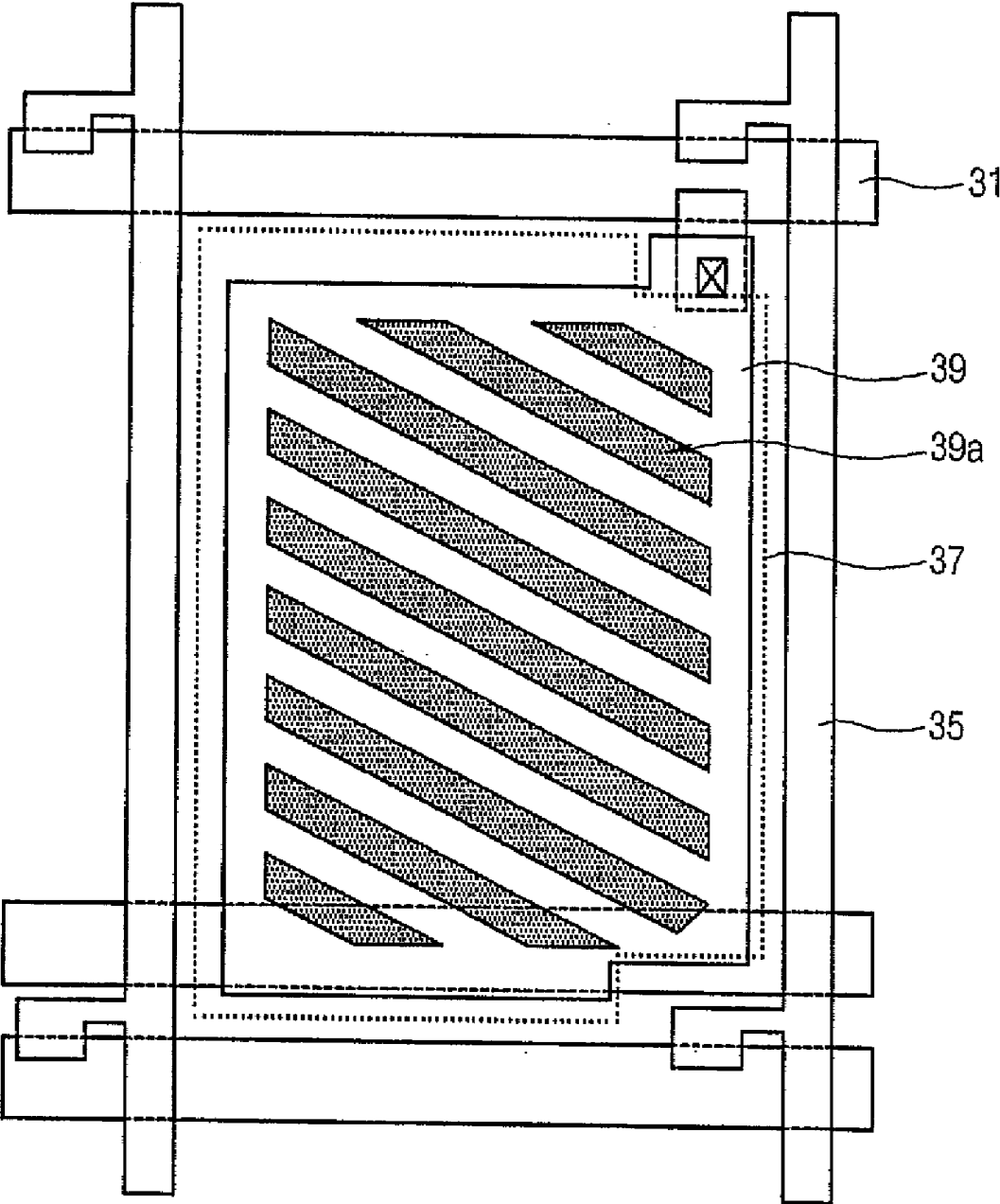

FIG. 2B

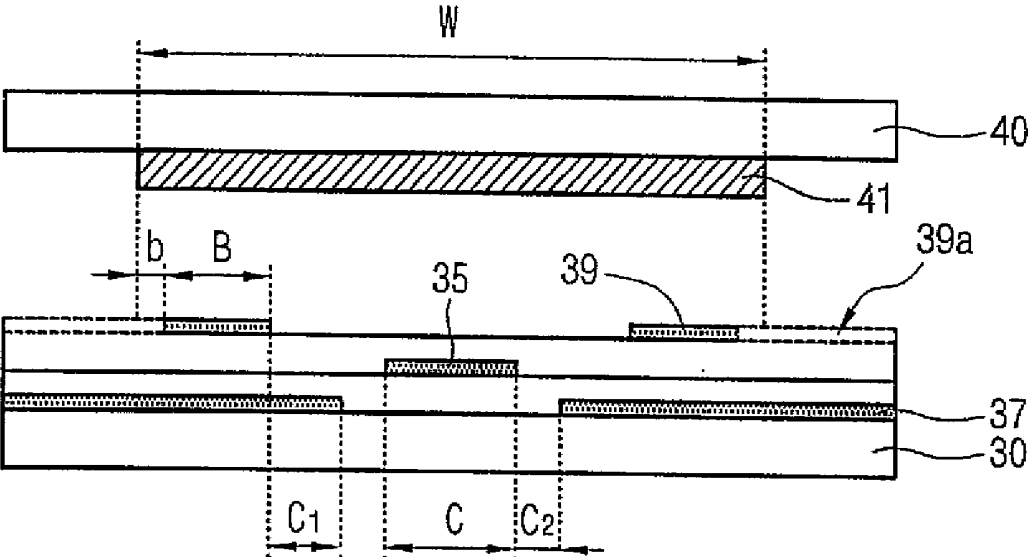

FIG. 3

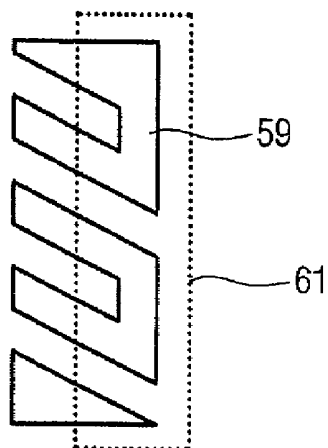
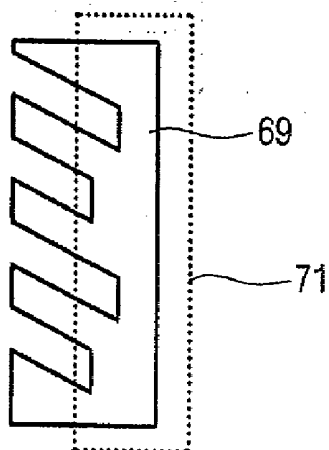

FIG. 4



FFS MODE LIQUID CRYSTAL DISPLAY

RELATED APPLICATIONS

[0001] This application is a continuation of U.S. patent application Ser. No. 10/883,422, which was filed on Jun. 30, 2004, and which is now abandoned.

BACKGROUND OF THE INVENTION

[0002] 1. Field of the invention

[0003] The present invention relates to a fringe field switching (hereinafter, simply referred to as "FFS") mode liquid crystal display, and more particularly to an FFS mode liquid crystal display capable of improving driving mura and luminance non-uniformity.

[0004] 2. Description of the Prior Art

[0005] A method for fabricating an ultra-FFS mode liquid crystal display may be described as follows, with reference to FIGS. 1A and 1B. Herein, FIG. 1A is a plan view of a conventional ultra-FFS mode liquid crystal display, and FIG. 1B is a sectional view thereof.

[0006] As shown in FIG. 1A, according to the conventional ultra-FFS mode liquid crystal display, a gate line **11** and a data line **15** are aligned to cross perpendicular to each other on a lower substrate **10**. Then, a first ITO electrode **17** is aligned in a region defined by the gate line **11** and the data line **15** and a second ITO electrode **19** for a pixel electrode is aligned while overlapping with the first ITO electrode **17**. The orientation of liquid crystal is aligned at 0 degrees. Herein, the second ITO electrode **19** for the pixel electrode includes a plurality of slit patterns **19a**, in which the slit patterns **19a** are formed in an inclined manner, so that the edge sections of the slit patterns **19a** have a wedge shape.

[0007] Also, as shown in FIG. 1B, an upper substrate **20** is disposed opposite to the lower substrate **10**, while being spaced from the lower substrate **10** by a predetermined interval, and a black matrix **21** is formed on the upper substrate **20**. Herein, the edge sections of the slit patterns **19a** having the wedge shape in the second ITO electrode **19** for the pixel electrode, which overlaps with the black matrix **21**, are disposed in a transmission region spaced by a length of 'a' to the outside from an edge section of the black matrix **21**. That is, the slit patterns **19a** of the second ITO electrode **19** are disposed while not overlapping with the black matrix **21**.

[0008] Owing to such a construction, when liquid crystal molecules are twisted by an electric field, upper liquid crystal molecules (a color filter substrate) and lower liquid crystal molecules (an array substrate) are twisted in opposite directions from each other, thereby compensating for chromatic shift toward a bluish color or a yellowish color, which is caused by dielectric anisotropy of the liquid crystal.

[0009] According to the conventional FFS mode liquid crystal display fabricated the above-mentioned method, since an overlapped region between electrodes is very wide, layers such as an insulation layer may be deteriorated due to long-period electrical operations, which results in inferior afterimages.

[0010] In order to correct such a disadvantage, various shapes and structures of electrodes have been studied and proposed.

[0011] However, according to conventional FFS pixels, the edge sections of the slit patterns having the wedge shape, which forms a non-uniform electric field (i.e. which causes distortion in the operation of liquid crystal) are not disposed in the black matrix but located in the actual transmission region.

[0012] As a result, such a relationship between the pixel wedge and the black matrix causes transmittance reduction and luminance non-uniformity due to an alternation operation between them, so that the characteristics of manufactured goods are deteriorated.

SUMMARY OF THE INVENTION

[0013] Accordingly, the present invention has been made to solve the above-mentioned problems occurring in the prior art, and an object of the present invention is to provide an FFS (Fringe Field Switching) mode liquid crystal display which can improve operating mura, luminance non-uniformity, etc., which have been problematic in the conventional FFS mode liquid crystal display, by establishing a new conception of mutual factors between a black matrix and a pixel electrode provided in an FFS design structure.

[0014] In order to accomplish this object, there is provided an FFS (Fringe Field Switching) mode liquid crystal display comprising: a lower substrate and an upper substrate; a gate line formed on the lower substrate; a data line crossing perpendicular to the gate line; a first ITO electrode formed in a region defined by the gate line and the data line; a second ITO electrode being formed on the lower substrate while overlapping with the first ITO electrode, and including a plurality of slit patterns having edge sections of a wedge shape; and a black matrix formed on the upper substrate, wherein the second ITO electrode is disposed such that the edge sections of the slit patterns having the wedge shape overlap with the black matrix.

BRIEF DESCRIPTION OF THE DRAWINGS

[0015] The above and other objects, features and advantages of the present invention will be more apparent from the following detailed description taken in conjunction with the accompanying drawings, in which:

[0016] FIG. 1A is a plan view of a conventional ultra-FFS mode liquid crystal display, and FIG. 1B is a sectional view thereof;

[0017] FIG. 2A is a layout view of an FFS mode liquid crystal display according to one embodiment of the present invention, and FIG. 2B is a sectional view of the FFS mode liquid crystal display shown in FIG. 2A; and

[0018] FIGS. 3 and 4 are schematic views for explaining the shapes of edge sections of slit patterns in FFS mode liquid crystal displays according to other embodiments of the present invention.

DETAILED DESCRIPTION OF THE PREFERRED EMBODIMENTS

[0019] Hereinafter, a preferred embodiment of the present invention will be described with reference to the accompanying drawings. In the following description and drawings, the same reference numerals are used to designate the same

or similar components, and so repetition of the description on the same or similar components will be omitted.

[0020] FIG. 2A is a layout view of an FFS (Fringe Field Switching) mode liquid crystal display according to one embodiment of the present invention, and FIG. 2B is a sectional view of the FFS mode liquid crystal display according to this embodiment of the present invention.

[0021] FIGS. 3 and 4 are schematic views for explaining FFS mode liquid crystal displays according to other embodiments of the present invention, in which a wedge portion of a second ITO electrode is formed with removed parts spaced from each other, so as to improve distortion of liquid crystal.

[0022] As shown in FIG. 2A according to an FFS mode liquid crystal display of one embodiment of the present invention, a gate line 31 and a data line 35 are aligned to cross perpendicular to each other on a lower substrate 30. A first ITO electrode 37 is aligned in a region defined by the gate line 31 and the data line 35 and. A second ITO electrode 39 for a pixel electrode is aligned while overlapping with the first ITO electrode 37. The orientation of liquid crystal is aligned at 0°. Herein, the second ITO electrode 39 for the pixel electrode includes a plurality of slit patterns 39a, in which the slit patterns 39a are formed in an inclined manner, so that the edge sections of the slit patterns 39a have a wedge shape.

[0023] In addition, as shown in FIG. 2B, an upper substrate 40 is disposed opposite to the lower substrate 30, while being spaced from the lower substrate 30 by a predetermined interval, and a black matrix 41 is formed on the upper substrate 40. The black matrix 41 is formed using conductive material which has a resistance of $1 \times 10^{-2} \Omega\text{cm}$ to $1 \times 10^{-7} \Omega\text{cm}$. Also, the black matrix 41 is formed to have a width of 22 μm or less.

[0024] Herein, different from the conventional construction, the second ITO electrode 39 for a pixel electrode located on the lower substrate 30 according to the present invention is formed with the slit patterns 39a extended by a length of 'b', for example, by 0.5 μm or more, to the inside from an edge section of the black matrix 41. In other words, the slit patterns 39a having the wedge shape are disposed in such a manner that the edge sections of the slit patterns 39a overlap with the black matrix 41 by a width of 0.5 μm or more. Therefore, according to the FFS mode liquid crystal display of the present invention, it is possible to prevent afterimage or mura due to distortion of liquid crystal, which occurs around the edge sections of the slit patterns 39a, from being displayed on the screen.

[0025] Meanwhile, according to other embodiments of the present invention, the shape of the slit pattern in the second ITO electrode for a pixel electrode may be modified as shown in FIGS. 3 and 4, so that the distortion of liquid crystal can be minimized. FIG. 3 shows a second ITO electrode 59 including slit patterns 59a which are alternatively and oppositely opened on one side, so that the second ITO electrode 59 has a serpentine shape. FIG. 4 is a second ITO electrode 69, in which slit patterns 69a having different lengths are alternately disposed. Herein, the edge sections of all the slit patterns 59a and 69a shown in FIGS. 3 and 4 are disposed while overlapping with black matrixes 61 and 71.

[0026] As described above, according to the FFS mode liquid crystal display of the present invention, the edge

sections of the slit pattern having a wedge shape in the second ITO electrode are disposed while overlapping with the conductive black matrix, so that it is possible to prevent distortion of liquid crystal occurring around the edge sections of the slit pattern (i.e. distortion of liquid crystal occurring due to electric field interference between the conductive black matrix and the edge sections of the slit pattern having the wedge shape) from being displayed on the screen. Accordingly, mura (i.e. block, Y-block, and luminance non-uniformity) and afterimages (i.e. un stability of liquid crystal due to an unstable operation) can be improved.

[0027] Although a preferred embodiment of the present invention has been described for illustrative purposes, those skilled in the art will appreciate that various modifications, additions and substitutions are possible, without departing from the scope and spirit of the invention as disclosed in the accompanying claims.

What is claimed is:

1. An FFS (Fringe Field Switching) mode liquid crystal display comprising:

a lower substrate including a gate line and a data line crossing perpendicular to the gate line;

a first ITO electrode formed in a region defined by the gate line and the data line, the first ITO electrode being a plate-type electrode; and

a second ITO electrode formed on the lower substrate while overlapping with the first ITO electrode, the second ITO electrode including a plurality of slit patterns having edge sections of a wedge shape, the edge sections of the slit pattern extending toward the data line; and

an upper substrate including a conductive black matrix formed on the upper substrate, the resistance of the conductive black matrix having a resistance of $1 \times 10^{-2} \Omega\text{-cm}$ to $1 \times 10^{-7} \Omega\text{-cm}$, wherein edge sections of the slit patterns extending toward the data line are formed at a position spaced by a predetermined interval to the inside from an edge section of the black matrix, which is disposed above the data line.

2. The FFS mode liquid crystal display as claimed in claim 1, wherein the edge section of the slit pattern in the second ITO electrode overlaps by 0.5 μm or more to an inside with an edge section of the black matrix.

3. The FFS mode liquid crystal display as claimed in claim 1, wherein the second ITO electrode includes slit patterns, which are alternatively and oppositely opened on one side.

4. The FFS mode liquid crystal display as claimed in claim 1, wherein the second ITO electrode includes slit patterns of different lengths, which are alternatively aligned.

5. The FFS mode liquid crystal display as claimed in claim 1, wherein the black matrix has a width of 22 μm or less.

6. An FFS (Fringe Field Switching) mode liquid crystal display comprising:

a lower substrate including a gate line and a data line crossing substantially perpendicular to the gate line;

an upper substrate;

a first electrode formed in a region defined by the gate line and the data line;

a second electrode formed on the lower substrate while overlapping with the first ITO electrode, the second electrode including a plurality of slit patterns having edge sections, the edge sections of the slit patterns extending toward the data line; and

a conductive black matrix selectively formed on the upper substrate, the resistance of the conductive black matrix being $1 \times 10^{-2} \Omega\text{-cm}$ to $1 \times 10^{-7} \Omega\text{-cm}$ wherein the edge sections of the slit patterns extending toward the data line are formed at a position spaced by a predetermined interval to the inside from an edge section of the black matrix, which is disposed above the data line.

7. The FFS mode liquid crystal display as claimed 7, wherein the edge section of the slit pattern in the second electrode overlaps by $0.5 \mu\text{m}$ or more, to an inside with an edge section of the black matrix.

8. The FFS mode liquid crystal display as claimed 7, wherein the second electrode includes slit patterns, which are alternatively and oppositely opened on one side.

9. The FFS mode liquid crystal display as claimed 7, wherein the black matrix has a width of $22 \mu\text{m}$ or less.

10. The FFS mode liquid crystal display as claimed 7, the first electrode is a plate-type electrode.

* * * * *

专利名称(译)	FFS模式液晶显示器		
公开(公告)号	US20070296902A1	公开(公告)日	2007-12-27
申请号	US11/853125	申请日	2007-09-11
[标]申请(专利权)人(译)	李敬^ h 金香ÿ JEON JONGÿ 安驰W [—]		
申请(专利权)人(译)	李敬^ h 金香ÿ JEON JONGÿ 安驰W [—]		
当前申请(专利权)人(译)	HYDIS TECHNOLOGIES CO. , LTD.		
[标]发明人	LEE KYUNG HA KIM HYANG YUL JEON JONG YOB AN CHI WOOK		
发明人	LEE, KYUNG HA KIM, HYANG YUL JEON, JONG YOB AN, CHI WOOK		
IPC分类号	G02F1/1343 G02F1/13357 G02F1/1335 G02F1/1368		
CPC分类号	G02F1/134363 G02F1/133512		
优先权	1020030059242 2003-08-26 KR		
其他公开文献	US7535534		
外部链接	Espacenet USPTO		

摘要(译)

FFS (边缘场切换) 模式液晶显示器包括下基板和上基板以及形成在下基板上的栅极线。数据线垂直于栅极线交叉。第一ITO电极形成在由栅极线和数据线限定的区域中。梳齿图案的第二ITO电极形成在下基板上, 同时重叠在第一ITO电极上。形成在上基板上的黑矩阵, 其中, 第二ITO电极的楔形部分形成在从黑矩阵的边缘部分向内部隔开预定间隔的位置处。

