



(19) **United States**

(12) **Patent Application Publication**
O'Donnell

(10) **Pub. No.: US 2004/0036665 A1**

(43) **Pub. Date: Feb. 26, 2004**

(54) **DRIVE CIRCUIT FOR LIQUID CRYSTAL DISPLAYS AND METHOD THEREFOR**

Publication Classification

(76) **Inventor: Eugene Murphy O'Donnell, Fishers, IN (US)**

(51) **Int. Cl.⁷ G09G 3/36**

(52) **U.S. Cl. 345/87**

Correspondence Address:

**Joseph S Tripoli
Thomson Multimedia Licensing Inc
PO Box 5312
Princeton, NJ 08543-5312 (US)**

(57) **ABSTRACT**

In a display unit having an array of liquid crystal cells and a corresponding array of display driver circuits (10) for each of the liquid crystal cells (20), each display driver circuit in the corresponding array includes an analog memory element (14) and a differential amplifier (16) coupled between the analog memory element and the liquid crystal cell. The differential amplifier provides isolation between the analog memory element and the liquid crystal cell.

(21) **Appl. No.: 10/433,165**

(22) **PCT Filed: Nov. 29, 2001**

(86) **PCT No.: PCT/US01/44841**

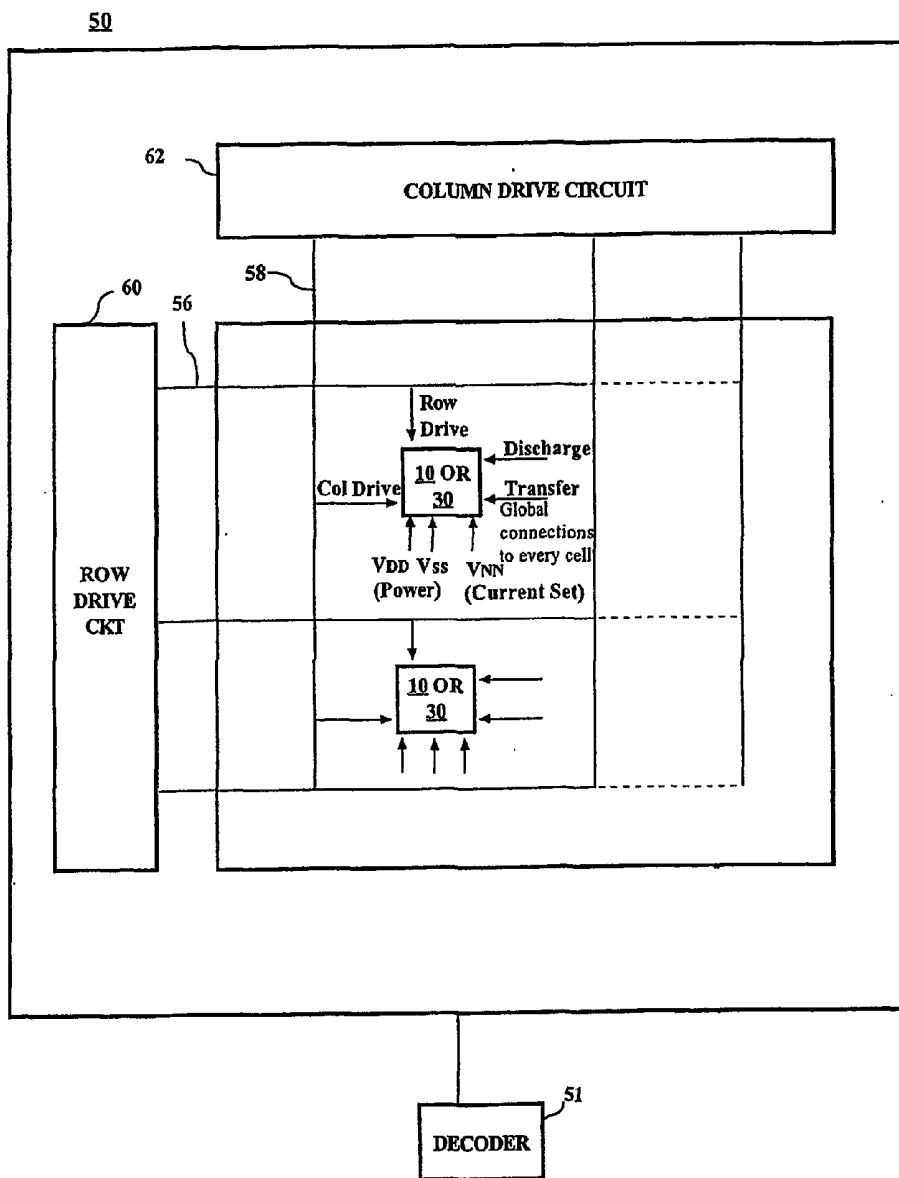

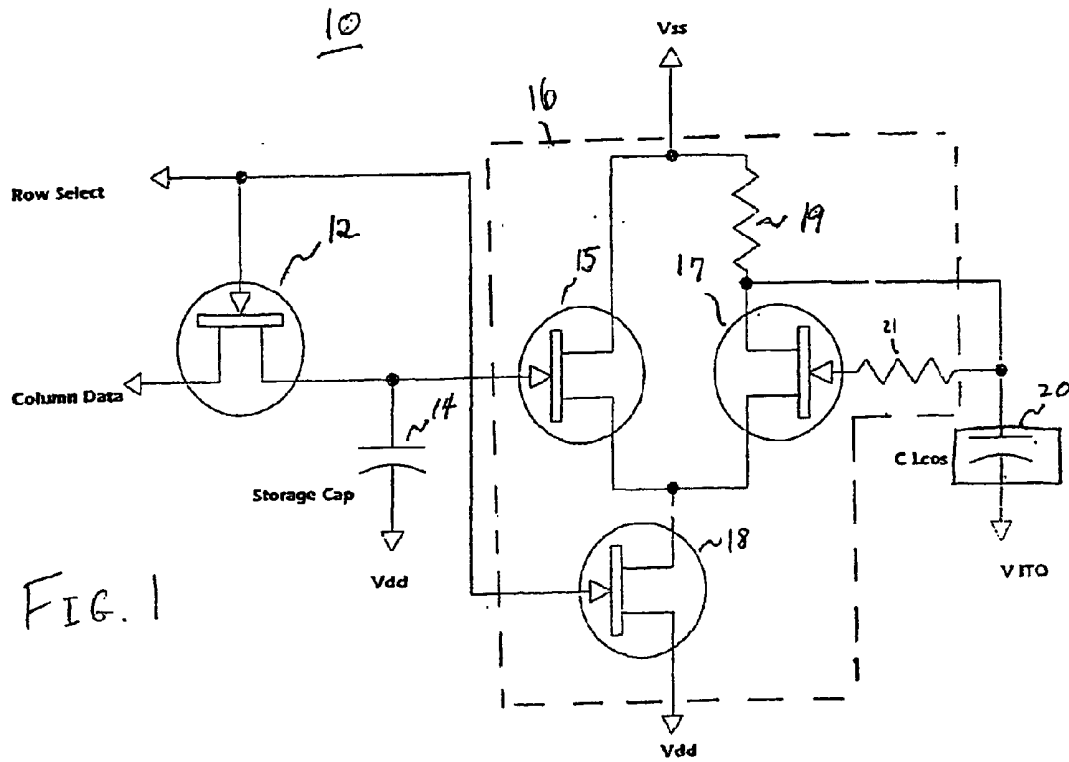

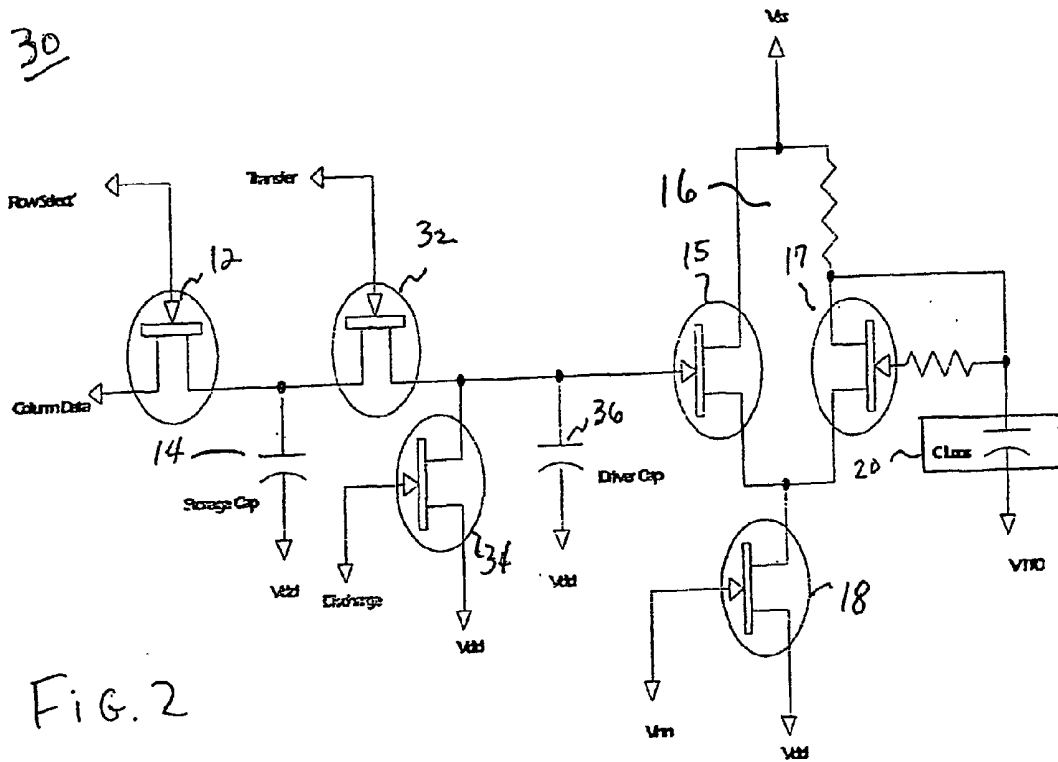

FIG. 3

50

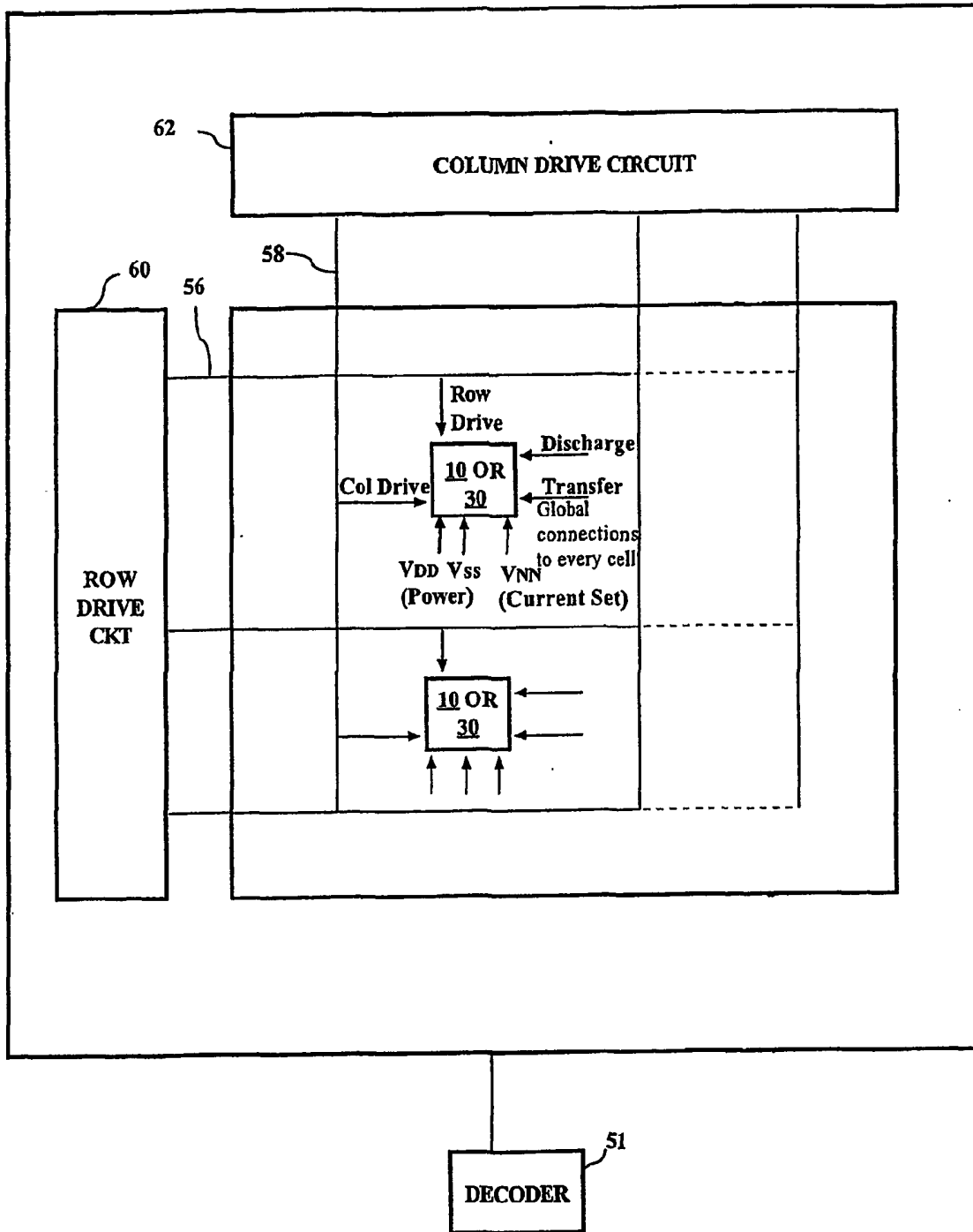
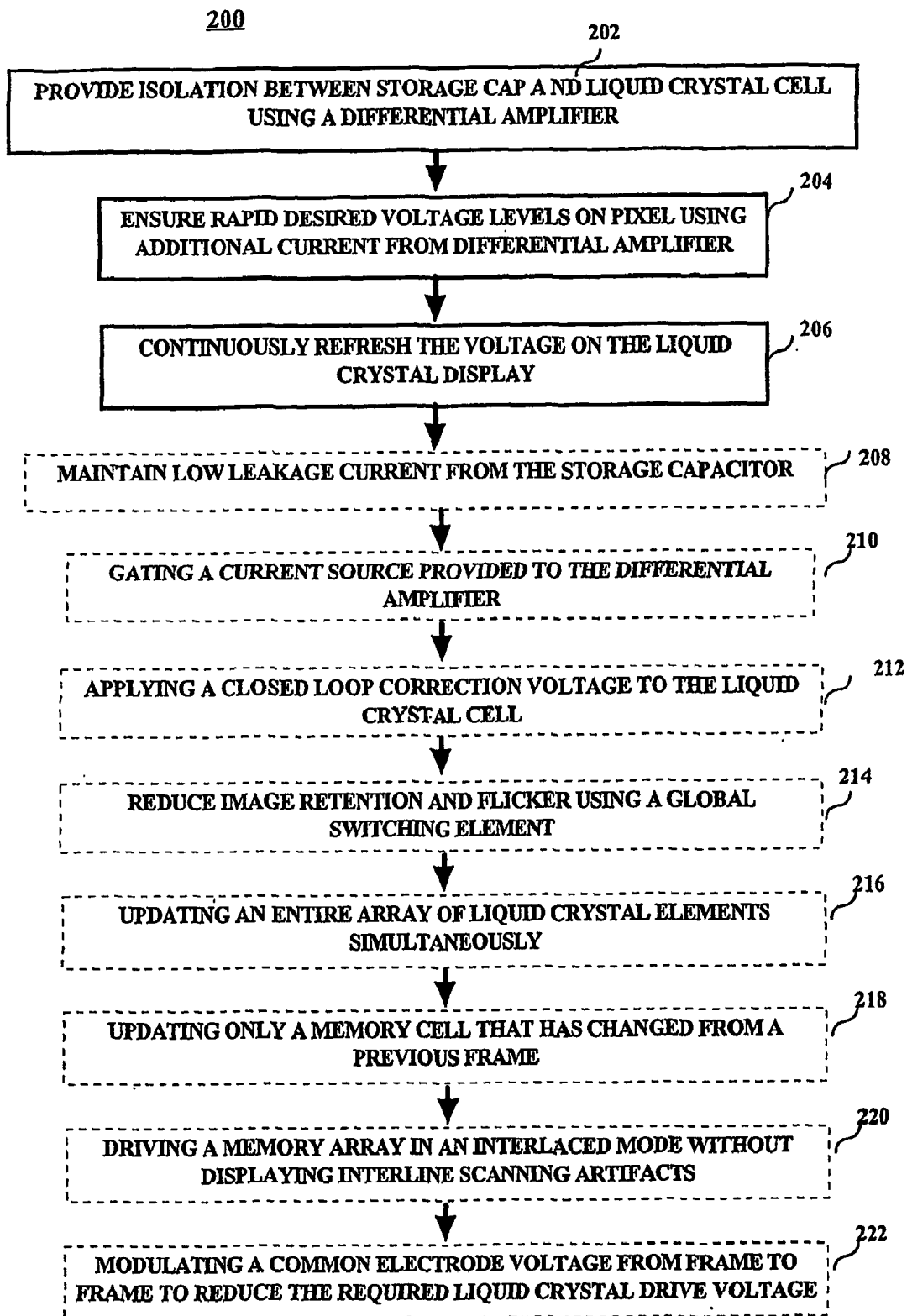

FIG. 4



DRIVE CIRCUIT FOR LIQUID CRYSTAL DISPLAYS AND METHOD THEREFOR

BACKGROUND OF THE INVENTION

[0001] 1. Field of the Invention

[0002] This invention relates to the field of video systems utilizing a liquid crystal display (LCD) or liquid crystal on silicon (LCOS), and in particular, to a driver circuit for such displays.

[0003] 2. Description of Related Art

[0004] Liquid crystal on silicon (LCOS) can be thought of as one large liquid crystal formed on a silicon wafer. The silicon wafer is divided into an incremental array of tiny plate electrodes. A tiny incremental region of the liquid crystal is influenced by the electric field generated by each tiny plate and the common plate. Each such tiny plate and corresponding liquid crystal region are together referred to as a cell of the imager. Each cell corresponds to an individually controllable pixel. A common plate electrode is disposed on the other side of the liquid crystal. The drive voltages are supplied to plate electrodes on each side of the LCOS array. Each cell, or pixel, remains lighted with the same intensity until the input signal is changed, thus acting as a sample and hold (so long as the voltage is maintained, the pixel brightness does not decay). Each set of common and variable plate electrodes forms an imager. One imager is typically provided for each color, in this case, one imager each for red, green and blue.

[0005] It is typical to drive the imager of an LCOS display with a frame-doubled signal to avoid 30 Hz flicker, by sending first a normal frame in which the voltage at the electrodes associated with each cell is positive with respect to the voltage at the common electrode (positive picture) and then an inverted frame in which the voltage at the electrodes associated with each cell is negative with respect to the voltage at the common electrode (negative picture) in response to a given input picture. The generation of positive and negative pictures ensures that each pixel will be written with a positive electric field followed by a negative electric field. The resulting drive field has a zero DC component, which is necessary to avoid image sticking, and ultimately, permanent degradation of the imager. It has been determined that the human eye responds to the average value of the brightness of the pixels produced by these positive and negative pictures so long as the frame rate is above 120 Hertz.

[0006] The present state of the art in LCOS requires the adjustment of the common-mode electrode voltage, denoted VITO, to be precisely between the positive and negative field drive for the LCOS. The subscript ITO refers to the material indium tin oxide. The average balance is necessary in order to minimize flicker, as well as to prevent a phenomenon known as image sticking.

[0007] In the current art, the LCOS drive cell looks much like a conventional Active Matrix LCD driver. This does not work well, due to the various artifacts discussed in the literature. The main causes are parasitic capacitance crosstalk, residual voltage in the LC cell, and voltage droop of the LC, due to ionic leakage and bulk resistivity of the LC material. Mainly this has been solved by 1. Increasing the cell capacitance (limited by physical area), 2. Changing to

higher resistivity LC materials (limits flexibility and response time), 3. Increasing the frame scan rate to more than 60 Hz (expensive, and costs more bandwidth), and 4. Strongly controlling the temperature of the device, to maintain high voltage holding ratio (VHR).

[0008] The main cause for all of the above issues is that the available charge is only transferred to the LC cell once per frame. In a display with a million pixels, this limits the available power and doesn't allow for any closed-loop check that the desired voltage has actually been achieved on the pixel electrode. Thus, a need exists for a display driver that provides adequate isolation between a storage capacitor and a liquid crystal cell and ensures that the desired voltage is achieved on the pixel electrode.

BRIEF SUMMARY OF THE INVENTION

[0009] In a first aspect of the present invention, a display driver circuit for a liquid crystal cell in an array of liquid crystal cells comprises a storage capacitance and an amplifier coupled between the capacitance and the liquid crystal cell.

[0010] In a second aspect of the present invention, a method for driving a display, comprising the steps of providing isolation between a storage capacitor and a liquid crystal cell using a differential amplifier, ensuring rapid desired voltage levels on a pixel using additional current provided by the differential amplifier and the step of continuously refreshing the voltage on the liquid crystal cell.

[0011] In a third aspect of the present invention, a display driver for a display unit which includes a plurality of display elements arranged in a matrix of rows and columns and a memory element and a liquid crystal cell. The display unit preferably comprises a driver for switchably outputting one of a plurality of voltages to the display elements on at least one of the matrix of rows and columns, the driver including a decoder and a plurality of analog switches, each analog switch being formed from a semiconductor switch and controlled to be opened or closed by an output signal of the decoder. The display driver also comprises a storage capacitor coupled between the decoder and the semiconductor switch and a differential amplifier coupled between the storage capacitor and the liquid crystal cell, whereby the differential amplifier provides isolation between the storage capacitor and the liquid crystal cell.

BRIEF DESCRIPTION OF THE DRAWINGS

[0012] FIG. 1 is a block diagram of a liquid crystal cell driver in accordance with the present invention.

[0013] FIG. 2 is a block diagram of another liquid crystal cell driver in accordance with the present invention.

[0014] FIG. 3 is a block diagram of a display unit utilizing a liquid crystal cell driver in accordance with the present invention.

[0015] FIG. 4 is a flow chart illustrating a method of driving a display in accordance with the present invention.

DETAILED DESCRIPTION OF THE PREFERRED EMBODIMENTS

[0016] In order to overcome the problems described above, it is proposed to add an amplifier such as a differential

amplifier 16 between the internal storage capacitor (14), and the LC cell (20) as shown in FIG. 1. In other words, a drive amplifier is added to the driving cell. This adds isolation between the storage capacitor and the LC cell. The added current drive capability ensures that the voltage on the pixel will rapidly become that desired and remain there. It also allows for very low leakage current from the storage capacitor (FET has very high input impedance), and allows for a continuous refresh of the voltage on the LC cell, which eliminates the 'droop' problem, as well as the residual voltaic potential stored in the cell. This should improve both the flicker issue, as well as the 'image sticking' problem which is associated with inability to achieve DC balance in the cell. It should also allow the cell to work well even at somewhat elevated temperatures.

[0017] The disadvantage of this technique is that it increases the DC current through the liquid crystal cell. This disadvantage can optionally be overcome in part by gating the current source in the bottom of the differential amplifier. This can use the 'pixel select' or "row select" bit in the device. In this way, a periodic refresh of the voltage can be achieved, while reducing the power consumption by 1/nrow, where nrow is the number of rows in the device. Since heating is uniform, this gating in some situations may not be needed.

[0018] A typical implementation in CMOS is shown in FIG. 1. The components are schematic representations, and alternate configurations can be used without loss of generality. The key points are the amplifier 16, which applies a closed loop correction voltage to the LC cell, and the optionally gated current source which allows reduction of power consumption.

[0019] Typically this circuit could be implemented with 3 transistors, which can be placed under the liquid crystal cell in an LCOS display device. In the arrangement of FIG. 1, an amplifier 16 decouples the LC cell from the memory element (the storage capacitor 14). FIG. 1 illustrates a liquid crystal cell driver 10 for a liquid crystal display. The liquid crystal cell driver preferably comprises a plurality of transistors (12, 15, 17, and 18), a storage capacitance such as the storage capacitor 14, and a plurality of resistors 19 and 21 and the liquid crystal cell represented by liquid crystal capacitance 20. Preferably, three (3) transistors, such as transistors 15, 17 and 18 form the amplifier 16, preferably in the form of a differential amplifier. The differential amplifier 16 is preferably comprised of N-Channel transistors having respective sources coupled and the drain of transistor 17 serving as an output to the liquid crystal cell (20). Additionally, the respective sources of the differential amplifier 16 are coupled and driven by a current source which is another N-Channel transistor such as transistor 18 that sets the balance current in the differential amplifier. The differential amplifier 16 is coupled between the storage capacitor 14 and provides isolation between the storage capacitor 14 and a liquid crystal cell 20 or pixel.

[0020] The arrangement of FIG. 2 adds a global switch element (32) to transfer data from the storage element to the driver. This allows for increased pixel drive for the same circuit operating voltages, and reduces image retention and flicker by allowing for inversion of the pixel drive voltage and the ITO transparent conductive electrode from frame to frame.

[0021] Referring to FIG. 2, another liquid crystal cell driver 30 is shown similar to the liquid crystal cell driver 10 of FIG. 1. In addition to the elements previously recited with respect to cell driver 10, cell driver 30 further comprises the global switch element 32 in the form of a transistor coupled between the storage capacitor 14 and the differential amplifier 16. The global switch element transfers data from the memory cell (14) to a driver capacitor 36 of the display driver.

[0022] The problem of flicker has been addressed by many mechanisms in the past. The issue of drive voltage and image retention has been addressed in digital drive LCOS displays.

[0023] The main benefit of the technique disclosed herein is to separate the liquid crystal cell (20) from the storage capacitor. This separation as shown in FIG. 2 allows for updating all the cells of the entire LC array at one time if desired. The benefit of this is two-fold. First, this separation (with further pre-processing to determine which LC cells have changed from frame to frame) also allows for updating of only the cells in the LC array that have changed from a prior frame. In other words, the contents of the storage capacitor 14 can be changed without instantaneously changing the display content on the LC cells. This greatly reduces the data rate needed for static pictures. It also allows for the possibility of driving the display in an interlaced mode without displaying interline scanning artifacts. In a system which is interlaced, normally odd lines are written on a first scan, and even lines are written on a second scan. This scanning scheme produces the artifact known as 'interline flicker'. This even happens for data which is not intrinsically interlaced, such as film. The reason for "interline flicker" is that the even lines from one frame are displayed at the same time that the odd lines from the previous frame are displayed. Any portion of the frame which changed will show an interline flicker. With the present invention, a display having an array of storage capacitors (14) corresponding to an array of LC cells would be updated just as normal (even lines followed by odd lines), except that the entire LC array would then be updated once the storage array has been filled. Thus, lines from different frames are never displayed simultaneously.

[0024] The second benefit of this technique is that it allows the common electrode voltage to be modulated from frame to frame. This modulation increases the effective electric field which can be applied to the LC for a given operating voltage of the driver circuit. This is a significant advantage, as finer process geometry will reduce the maximum allowed driving voltage.

[0025] The technique can most simply be implemented with the circuit described in FIG. 1, with a modification as shown in FIG. 2. The voltage V_{nn} of FIG. 2 is a static voltage which controls the current source for the transistors 15 and 17. The Row and Column address are normal addressing for an active matrix display. The control signals (Transfer and Discharge) are separate globally controlled signals which transfer the charge on the storage capacitor 14 to the drive capacitor 36, which drives the LC cell. The additional transistor 34 and capacitor 36 on the device are added to implement the new circuit and operationally allows for the adequate discharge of current from the storage capacitor 14 after each transfer. The additional components

should not be significant as process fabrication technology moves forward towards 0.1 microns and below.

[0026] Referring to FIG. 3, a display unit 50 is shown that can utilize the display drivers 10 or 30 as previously described above. The display unit 50 preferably includes a plurality of display elements arranged in a matrix of rows and columns and a memory element and a liquid crystal cell. The driver for each display element preferably switchably outputs one of a plurality of voltages to the display elements on at least one of the matrix of rows and columns, the display unit including a decoder 51 controlled by a conventional decoder 51. The driver (not shown in FIG. 3) can include a storage capacitor and a differential amplifier coupled between the storage capacitor and the liquid crystal cell, whereby the differential amplifier provides isolation between the storage capacitor and the liquid crystal cell. The display unit can include a decoder and a plurality of semiconductor switches such as shown in FIG. 1 or 2 controlled to be opened or closed by an output signal of the decoder 51. As shown in FIG. 3, the display unit 50 can include a row drive circuit having a plurality of row (scanning) address lines 56 and a column drive circuit 62 having a plurality of column (data) address lines 58.

[0027] Referring to FIG. 4, a flow chart is shown illustrating a method 200 of driving a display in accordance with the present invention. The method 200 preferably comprises the step 202 of providing isolation between a storage capacitor and a liquid crystal cell using a differential amplifier, the step 204 of ensuring rapid desired voltage levels on a pixel using additional current provided by the differential amplifier, and the step 206 of continuously refreshing the voltage on the liquid crystal cell. The method 200 may further comprise the step 208 of maintaining low leakage current from the storage capacitor and the step 210 of gating a current source provided to the differential amplifier. Additionally, the method 200 may further comprise the step 212 of applying a closed loop correction voltage to the liquid crystal cell. As applicable to display driver 30 of FIG. 2, the method 200 could comprise the step 214 of reducing image retention and flicker using a global switch element which is coupled between the storage capacitor and the differential amplifier and may further comprise the step 216 of updating an entire array of liquid crystal elements simultaneously. The method may also include the step 218 of updating only a memory cell that has changed from a previous frame. Additional benefits of the method 200 may include the step 220 of driving a memory array in an interlaced mode without displaying interline scanning artifacts and/or the step 222 of modulating a common electrode voltage from frame to frame to reduce a required liquid crystal drive voltage.

[0028] Although the present invention has been described in conjunction with the embodiments disclosed herein, it should be understood that the foregoing description is intended to illustrate and not limit the scope of the invention as defined by the claims.

1. In a display unit having an array of liquid crystal cells, comprising:

an array of display driver circuits for said liquid crystal cells, respectively, a given display driver circuit, including:

a storage capacitance; and

an amplifier coupled between the storage capacitance and the liquid crystal cell.

2. The display driver circuit of claim 1, wherein the amplifier comprises a differential amplifier.

3. The display driver of claim 2, wherein the differential amplifier provides isolation between the storage capacitance and the liquid crystal cell.

4. The display driver of claim 2, wherein the differential amplifier comprises a pair of N-Channel transistors having respective sources coupled and a drain from one of the pair of N-Channel transistors serving as an output to the liquid crystal cell.

5. The display driver of claim 2, wherein the differential amplifier comprises a pair of N-Channel transistors having respective sources coupled and a current source which is gated by another N-channel transistor that gates the current source and ensures a predetermined voltage on a pixel.

6. The display driver of claim 2, wherein the display driver further comprises a global switch element coupled between the storage capacitance and the differential amplifier, wherein the global switch element transfers data from the memory cell to the display driver.

7. The display driver circuit of claim 1, wherein said amplifier is responsive to a gating signal for reducing power consumption.

8. A method for driving a display, comprising the steps of:

providing isolation between a storage capacitor and a liquid crystal cell using a differential amplifier;

ensuring rapid desired voltage levels on a pixel using additional current provided by the differential amplifier; and

continuously refreshing the voltage on the liquid crystal cell.

9. The method of claim 8, wherein the method further comprises the step of maintaining low leakage current from the storage capacitor.

10. The method of claim 8, wherein the method further comprises the step of gating a current source provided to the differential amplifier.

11. The method of claim 8, wherein the method further comprises the step of applying a closed loop correction voltage to the liquid crystal cell.

12. The method of claim 8, wherein the method further comprises the step of reducing image retention and flicker using a global switch element which is coupled between the storage capacitor and the differential amplifier.

13. The method of claim 12, wherein the method further comprises the step of updating an entire array of liquid crystal elements simultaneously.

14. The method of claim 12, wherein the method further comprises the step of updating only the memory cells that have changed from a previous frame.

15. The method of claim 12, wherein the method further comprises the step of driving a memory array in an interlaced mode without displaying interline scanning artifacts.

16. The method of claim 12, wherein the method further comprises the step of modulating the common electrode voltage from frame to frame to reduce a required liquid crystal drive voltage.

17. A display driver for a display unit which includes a plurality of display elements arranged in a matrix of rows and columns, comprising:

a driver for switchably outputting one of a plurality of voltages to the display elements on at least one of the matrix of rows and columns, said driver including a decoder and a plurality of semiconductor switches controlled to be opened or closed by an output signal of said decoder;

a storage capacitor coupled between said decoder and said semiconductor switch for each of the plurality of display elements; and

a differential amplifier coupled between the storage capacitor and each of the plurality of display elements, whereby the differential amplifier provides isolation between the storage capacitor and a liquid crystal cell forming each of the plurality of display elements.

18. The display driver of claim 17, wherein the differential amplifier comprises a pair of N-Channel transistors having respective sources coupled and a drain from one of the pair of N-Channel transistors serving as an output to the liquid crystal cell.

19. The display driver of claim 17, wherein the differential amplifier comprises a pair of N-Channel transistors having respective sources coupled and serving as a current source which is gated by another N-channel transistor that gates the current source and ensures a predetermined voltage on a pixel.

20. The display driver of claim 17, wherein the display driver further comprises a global switch element coupled between the storage capacitor and the differential amplifier, wherein the global switch element transfers data from the memory cell to the display driver.

* * * * *

专利名称(译)	用于液晶显示器的驱动电路及其方法		
公开(公告)号	US20040036665A1	公开(公告)日	2004-02-26
申请号	US10/433165	申请日	2001-11-29
[标]申请(专利权)人(译)	奥唐奈EUGENE MURPHY		
申请(专利权)人(译)	O'DONNELL EUGENE MURPHY		
当前申请(专利权)人(译)	汤姆森许可S.A.		
[标]发明人	ODONNELL EUGENE MURPHY		
发明人	O'DONNELL, EUGENE MURPHY		
IPC分类号	G02F1/133 G02F1/1333 G02F1/1368 G09G3/20 G09G3/36 H03F3/45		
CPC分类号	G02F1/13306 G09G2320/0285 G09G3/2011 G09G3/3611 G09G3/3614 G09G3/3648 G09G3/3688 G09G2300/0809 G09G2300/0842 G09G2300/0852 G09G2310/0251 G09G2310/027 G09G2310/04 G09G2320/0233 G09G2320/0247 G02F1/1333		
优先权	60/250259 2000-11-30 US		
其他公开文献	US7782285		
外部链接	Espacenet USPTO		

摘要(译)

在具有用于每个液晶单元 (20) 的液晶单元阵列和相应的显示驱动电路 (10) 阵列的显示单元中，相应阵列中的每个显示驱动电路包括模拟存储元件 (14) 和差分放大器 (16) 耦合在模拟存储元件和液晶单元之间。差分放大器提供模拟存储元件和液晶单元之间的隔离。

