



(19) **United States**

(12) **Patent Application Publication**
Park et al.

(10) **Pub. No.: US 2002/0113931 A1**

(43) **Pub. Date: Aug. 22, 2002**

(54) **LIQUID CRYSTAL DISPLAY HAVING
IMPROVED CONTRAST RATIO AND
COLOR REPRODUCTION WHEN VIEWED
IN THE LATERAL DIRECTION**

(52) **U.S. Cl. 349/141**

(76) **Inventors: Seung-Beom Park, Seoul (KR);
Kyeong-Hyeon Kim, Suwon-City (KR)**

(57) **ABSTRACT**

Correspondence Address:
Frank Chau
F. CHAU & ASSOCIATES, LLP
Suite 501
1900 Hempstead Turnpike
East Meadow, NY 11554 (US)

Pluralities of pixel electrodes having openings and thin film transistors are provided on a lower panel, a common electrode having apertures is provided on an upper panel, and a liquid crystal layer vertically aligned to the two panels is located between the lower and the upper panels. The upper and the lower polarizers having the perpendicular polarizing directions are provided on the outer surfaces of the upper and the lower panels, respectively. The voltage value of a first gray representing the darkest state applied between the pixel electrode and the common electrode is within a voltage range giving a contrast ratio to be equal to or higher than 0.8 with respect to contrast ratio when the voltage applied between the pixel electrode and the common electrode is zero. In this way, the contrast ratio and the color reproduction is improved, so that the image quality of a liquid crystal display is improved.

(21) **Appl. No.: 09/992,474**

(22) **Filed: Nov. 14, 2001**

(30) **Foreign Application Priority Data**

Nov. 14, 2000 (KR) 2000-0067391

Publication Classification

(51) **Int. Cl.⁷ G02F 1/1343**

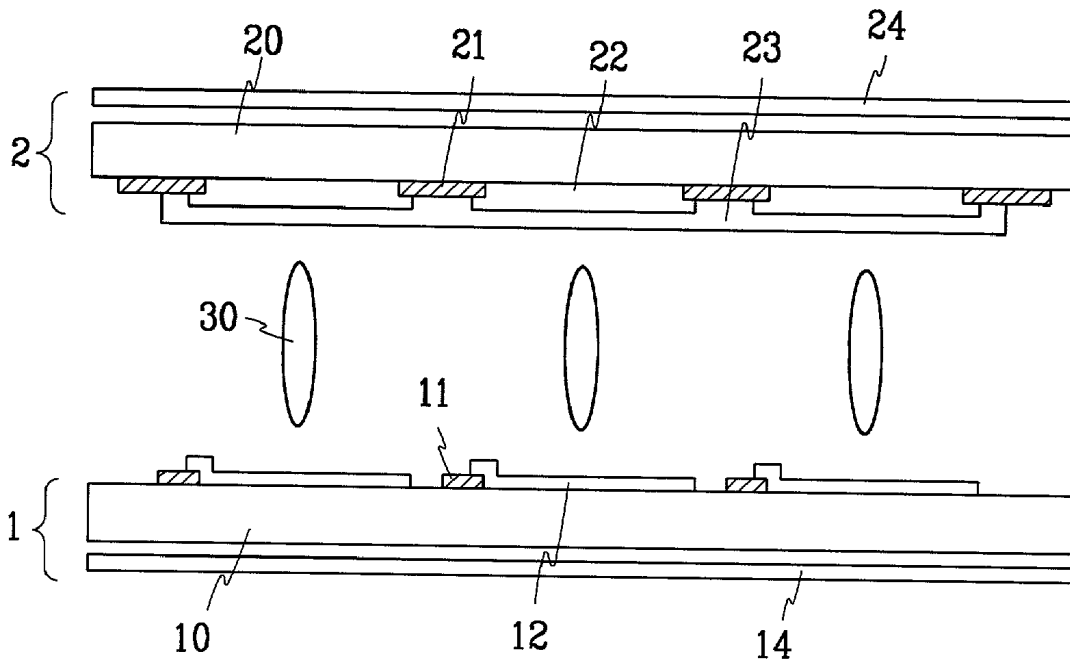

Fig.1a

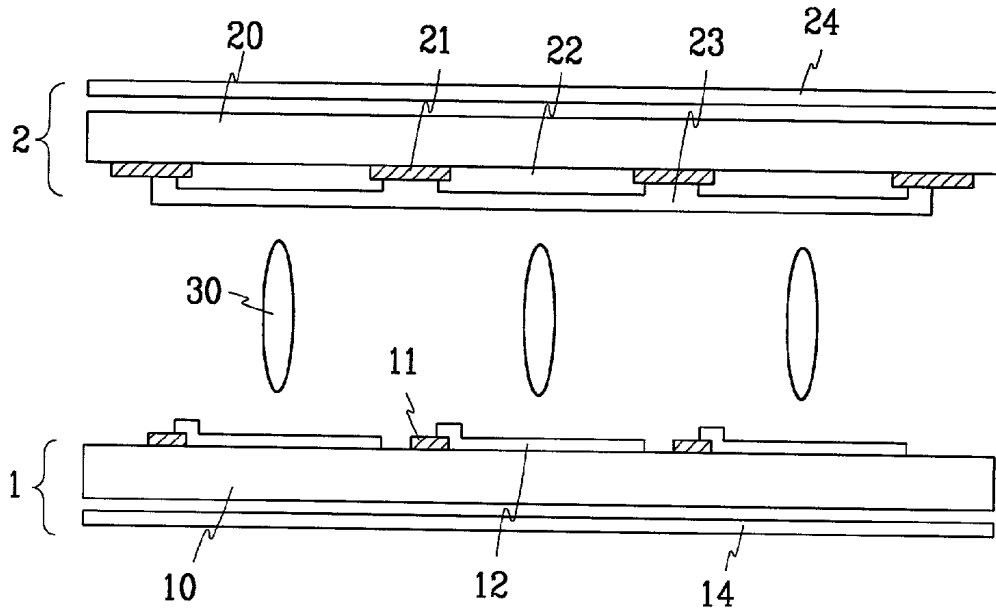

Fig.1b

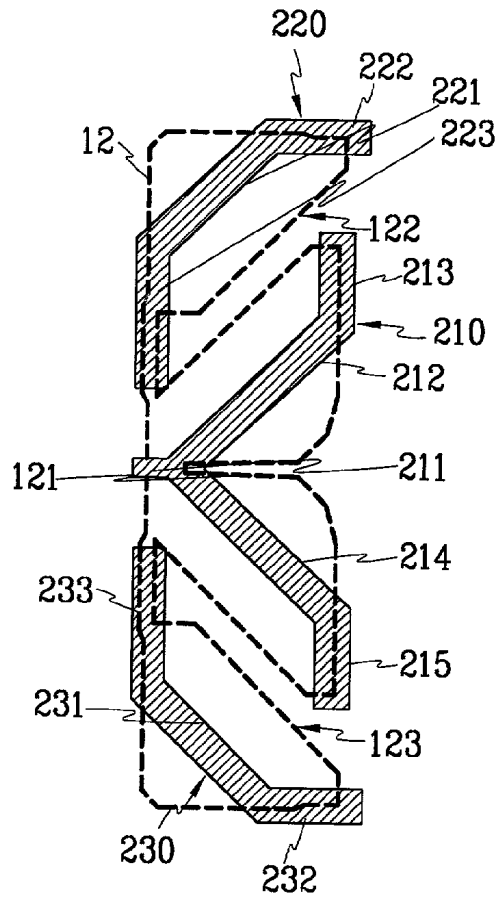

Fig. 2

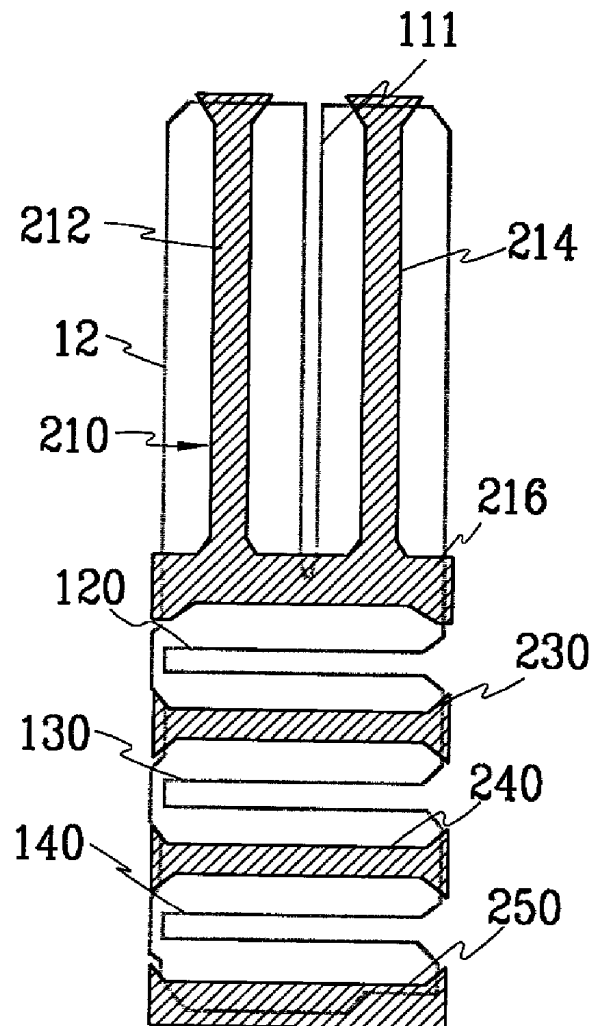

Fig.3a

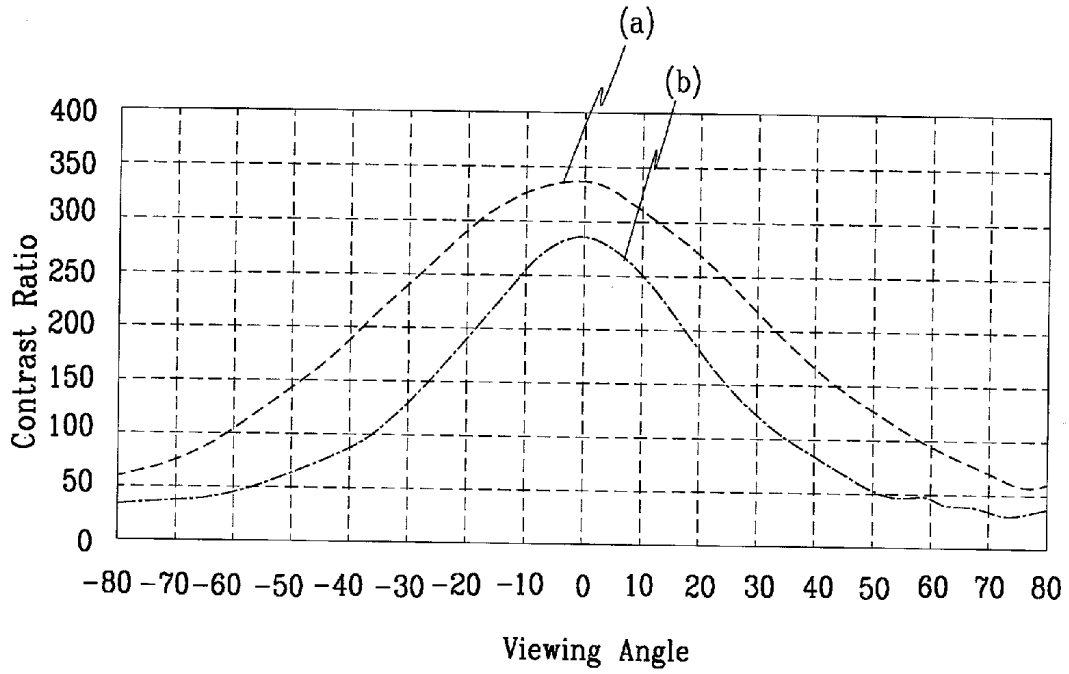

Fig.3b

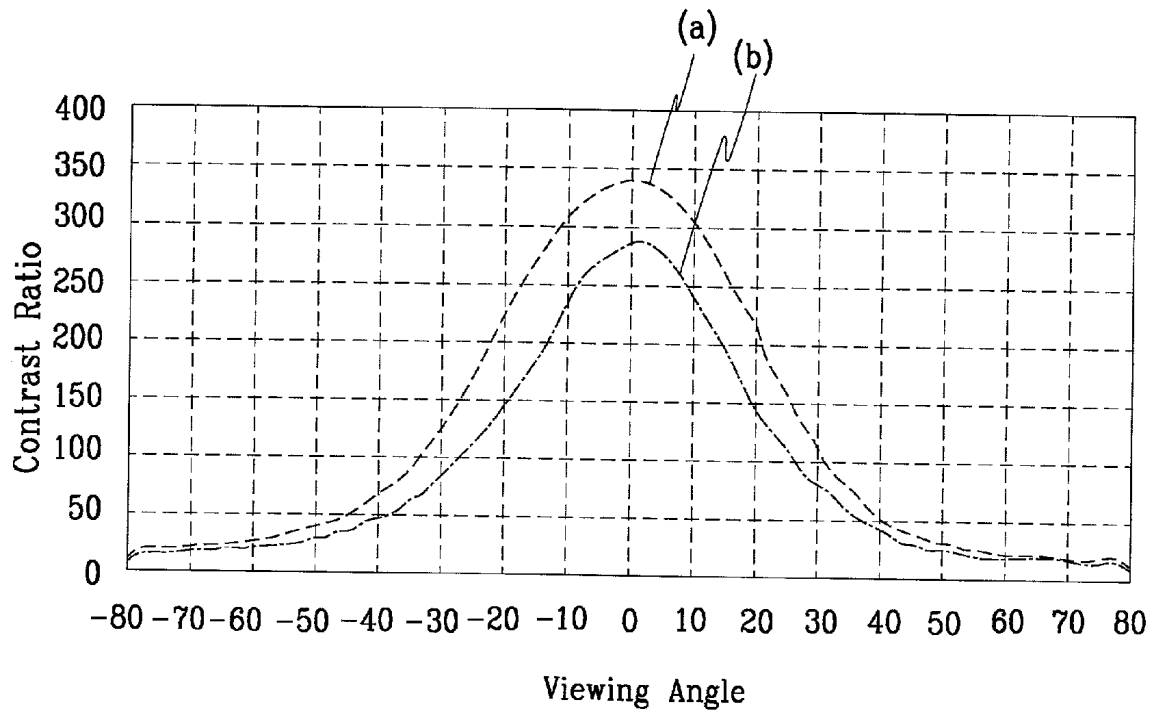

Fig.3c

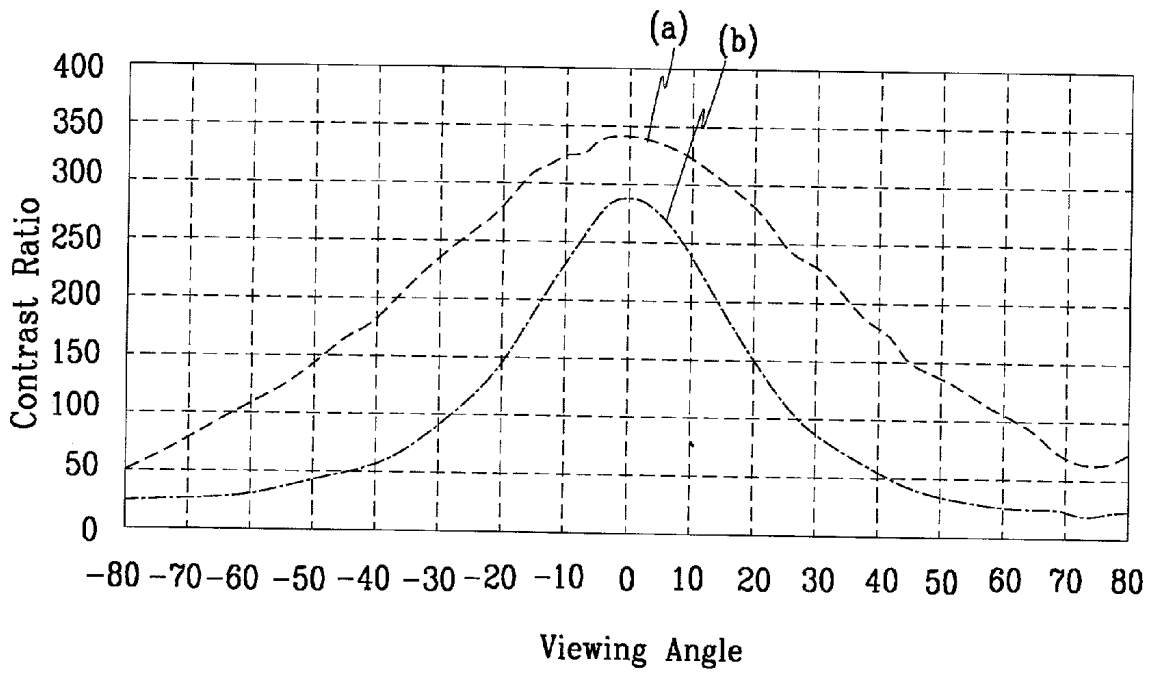

Fig.3d

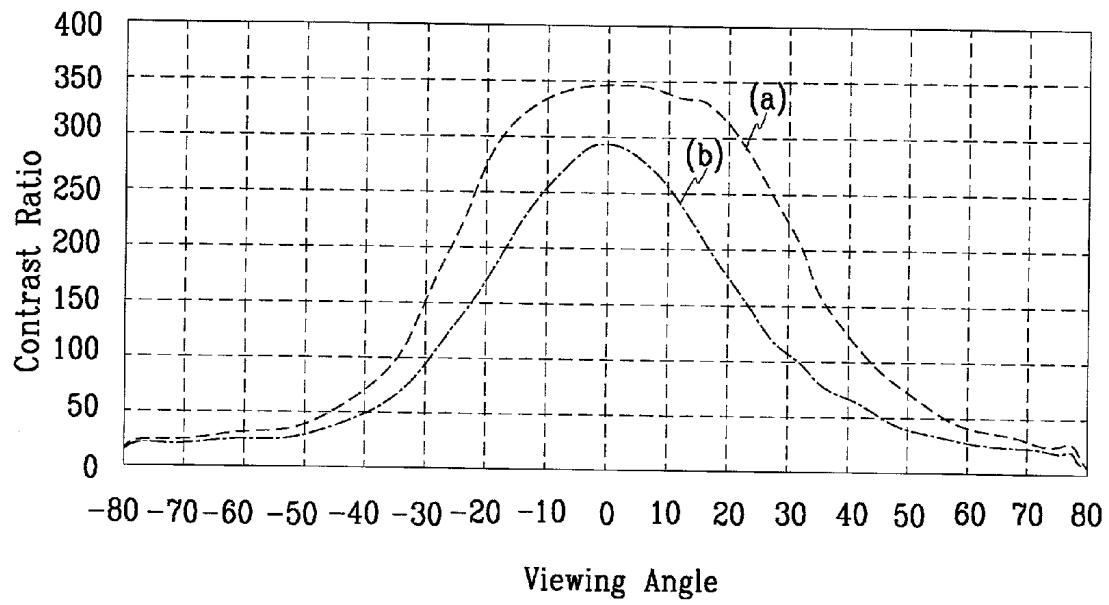

Fig.4a

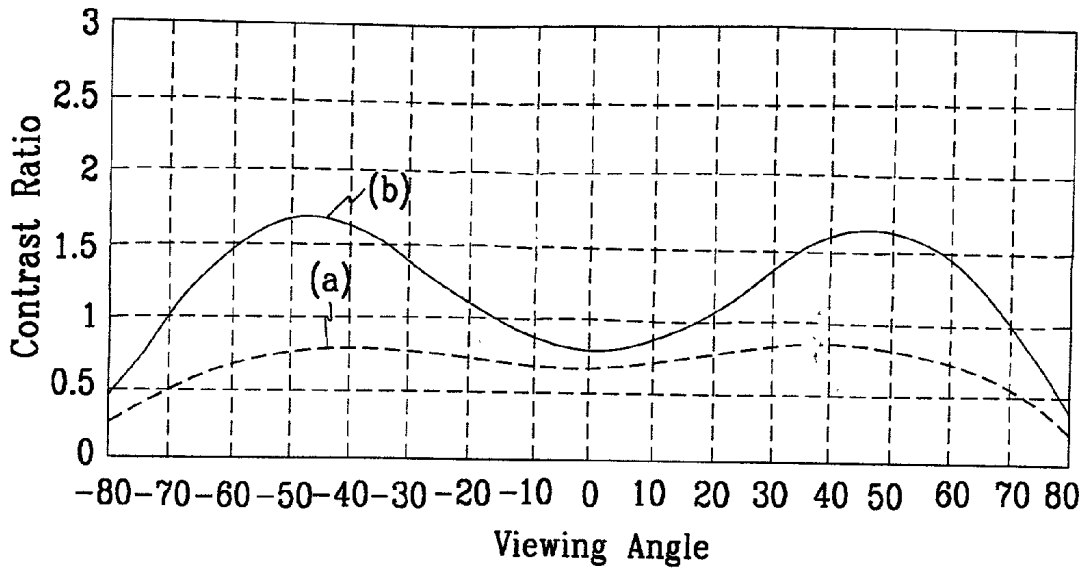

Fig.4b

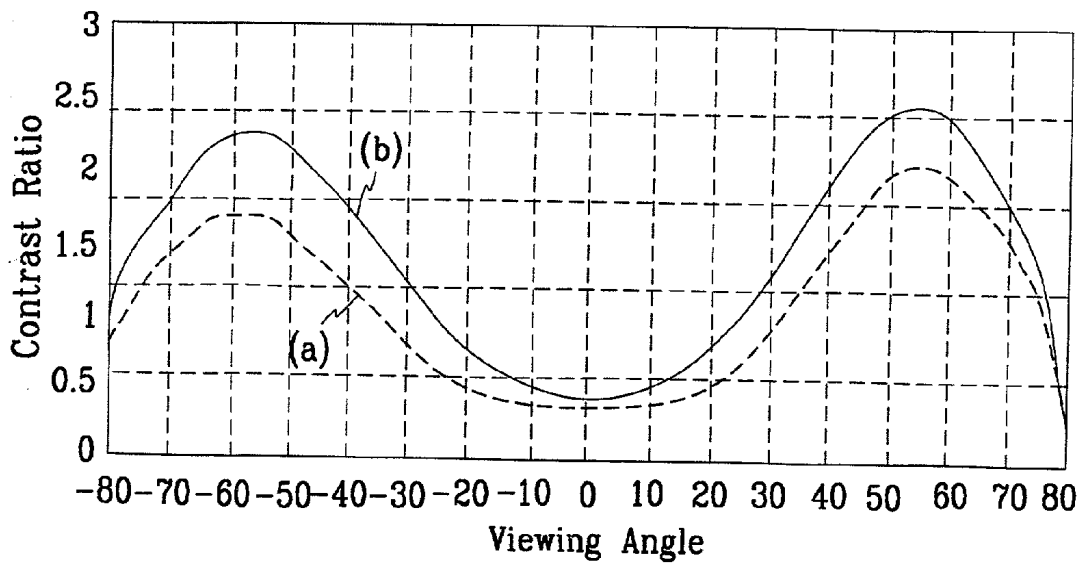

FIG. 4c

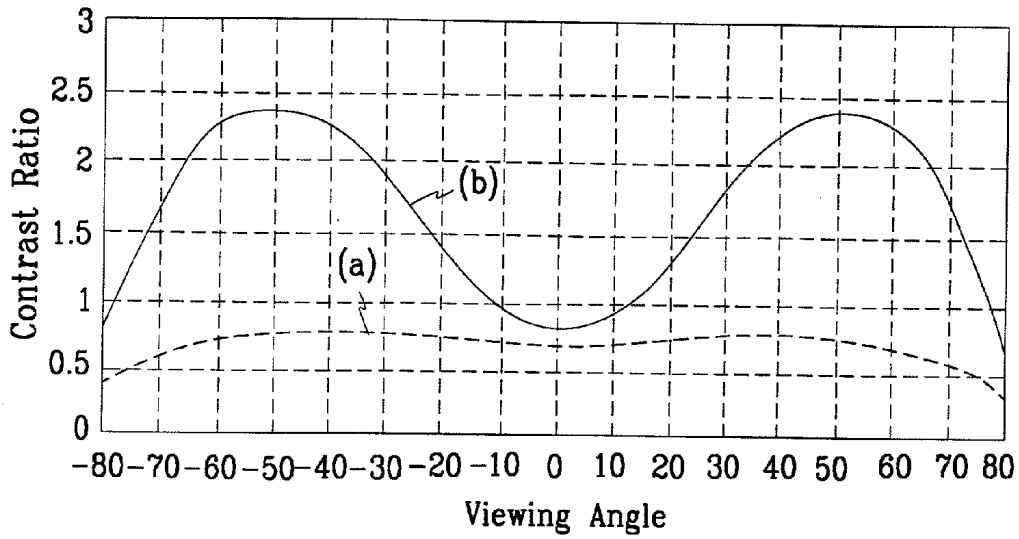

FIG. 4d

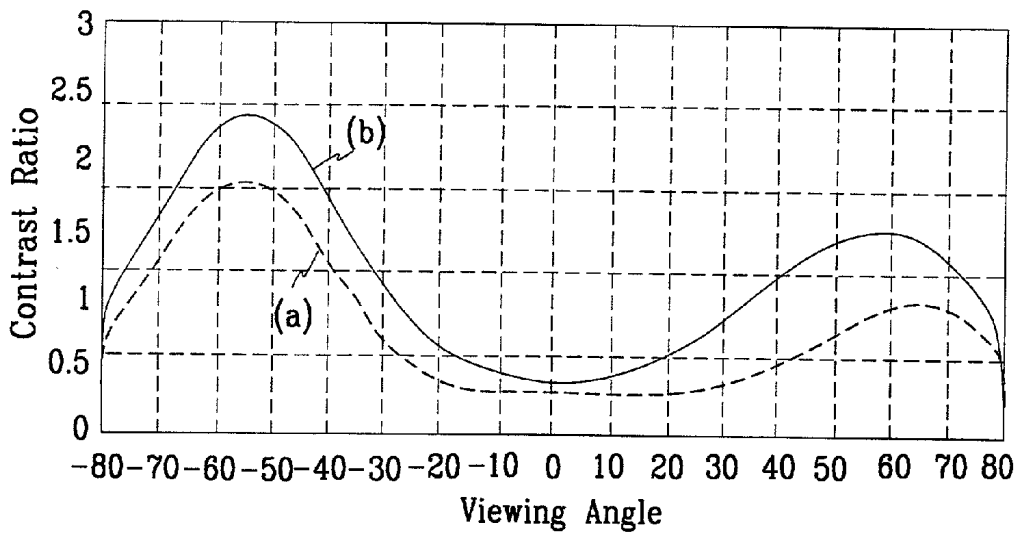

FIG.5a

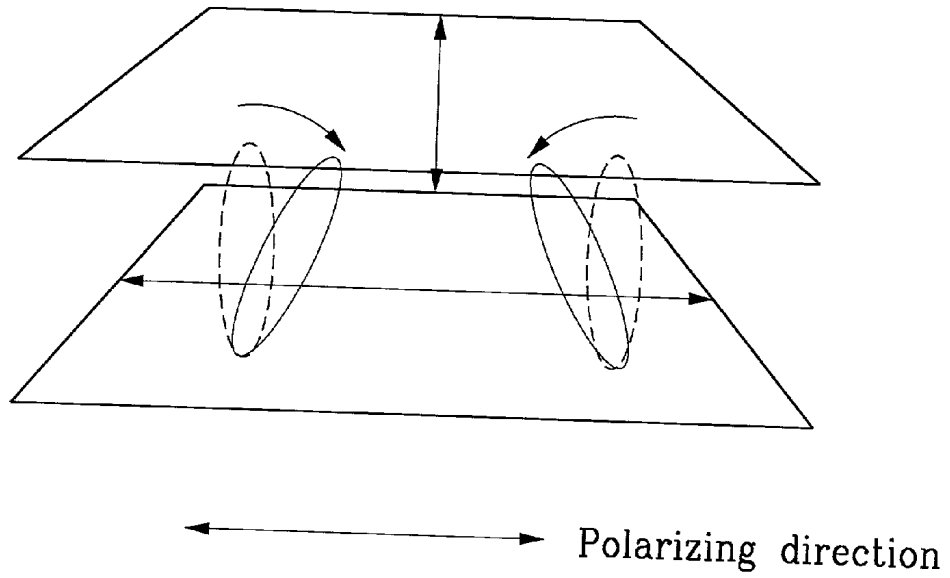

FIG.5b

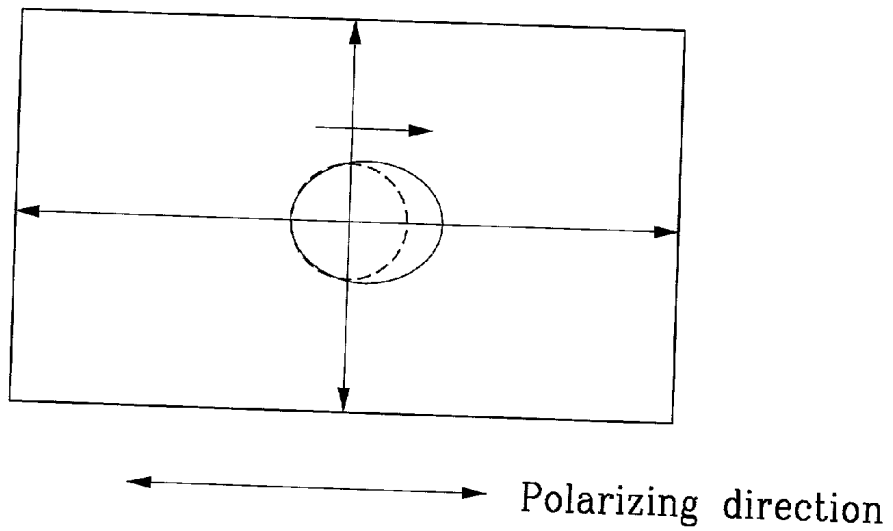

FIG. 5c

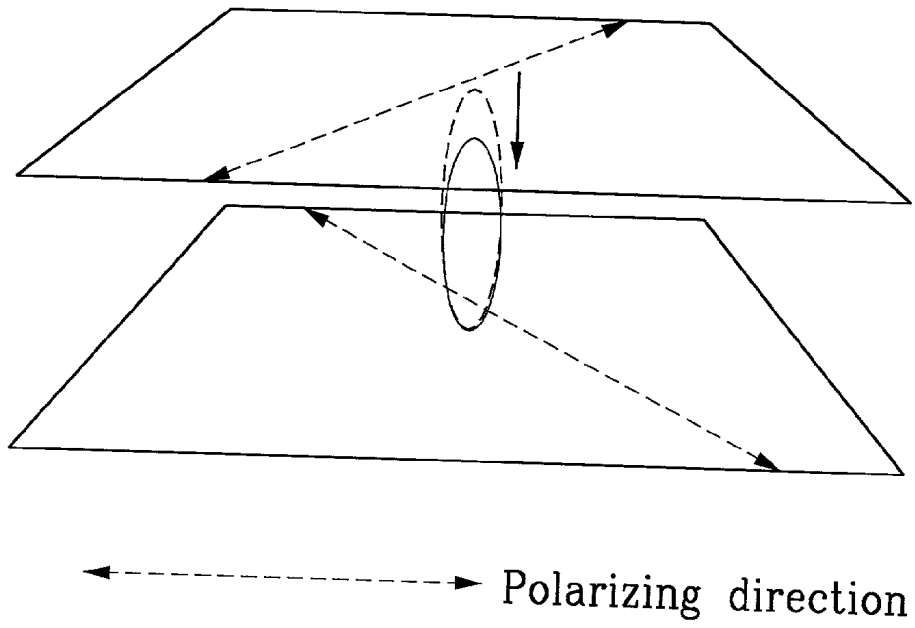

FIG. 5d

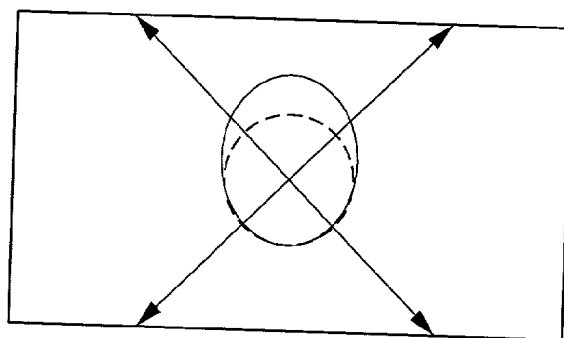

FIG.6a

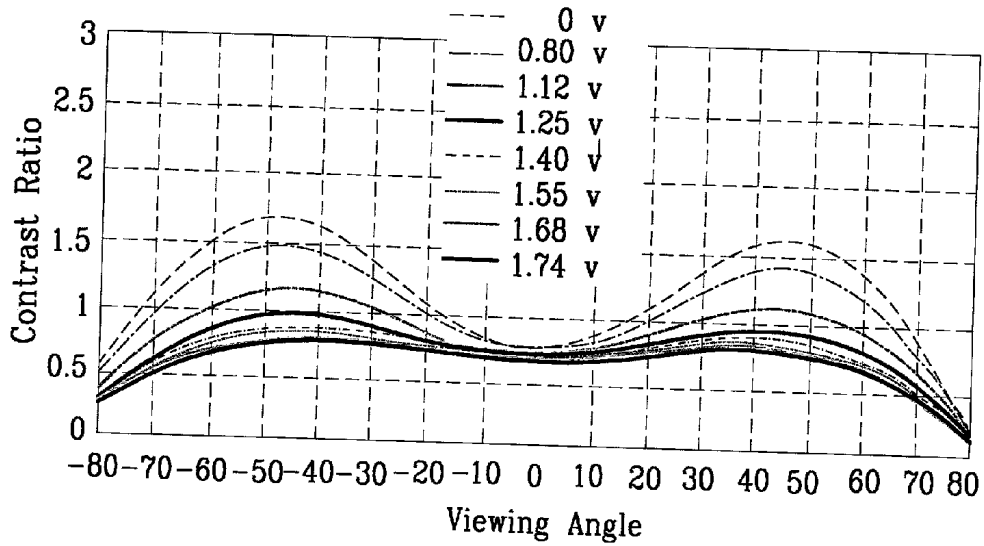

FIG.6b

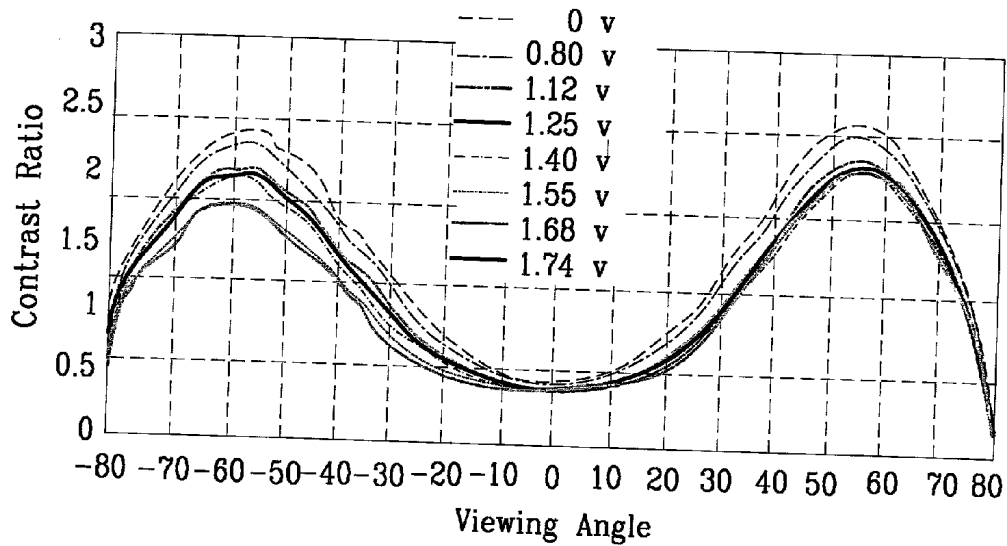

FIG. 6c

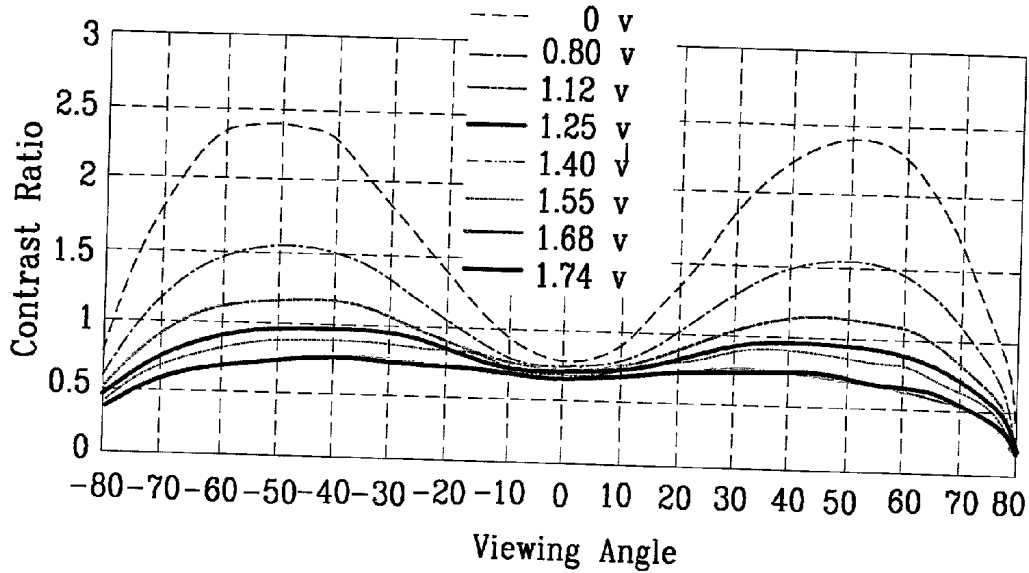

FIG. 6d

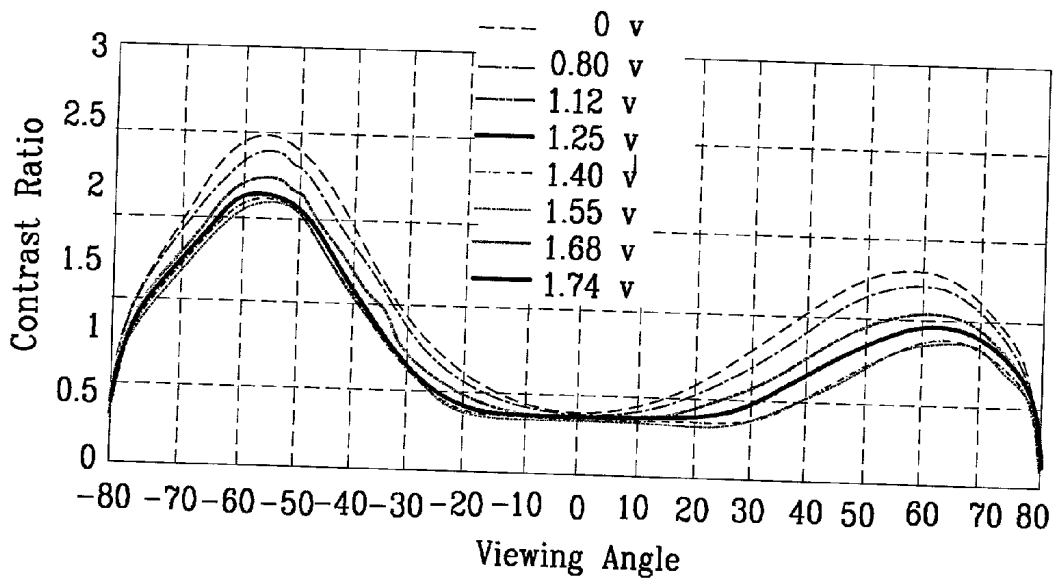

FIG. 7c

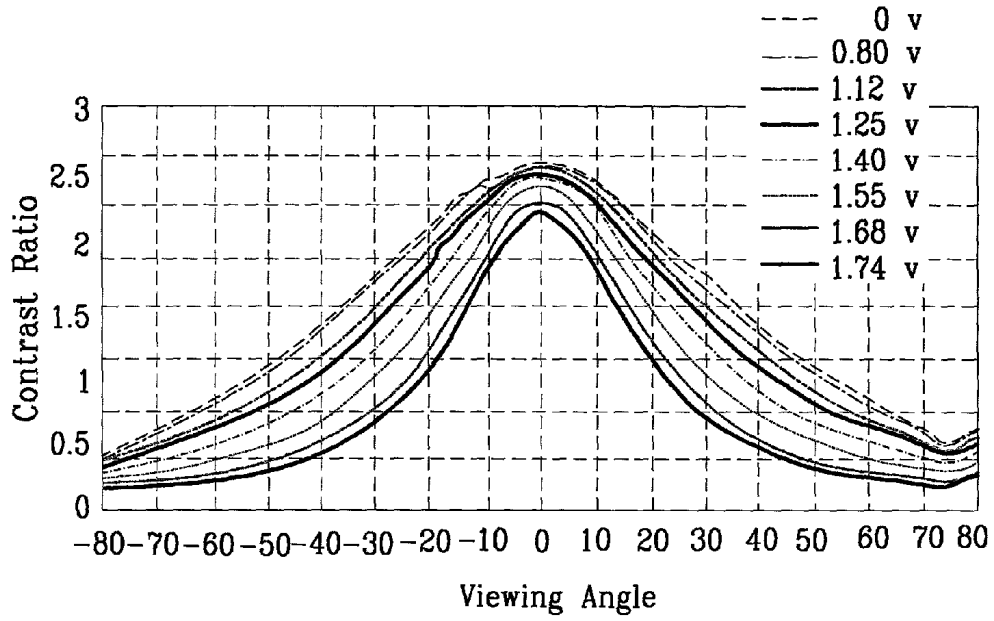

FIG. 7d

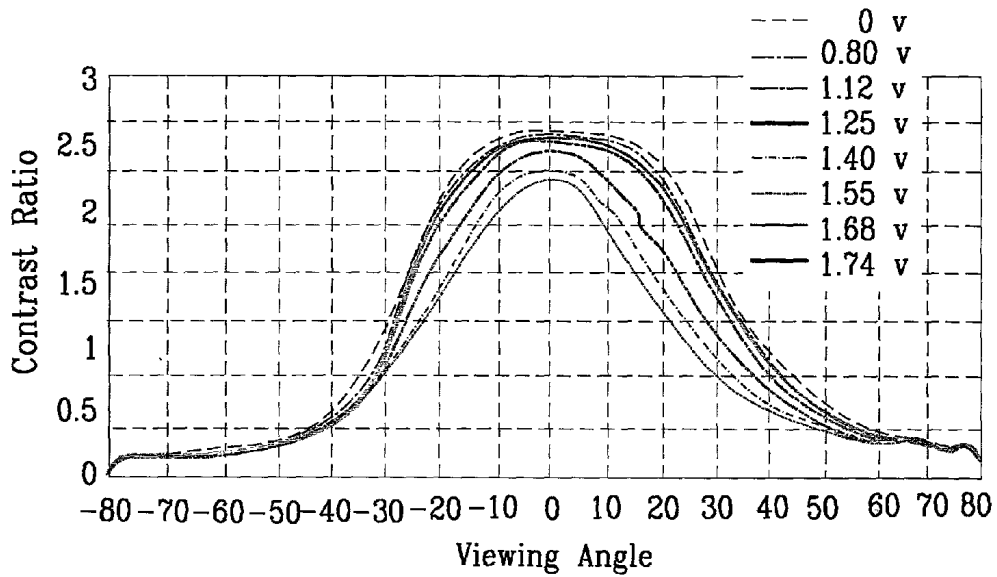

FIG.8

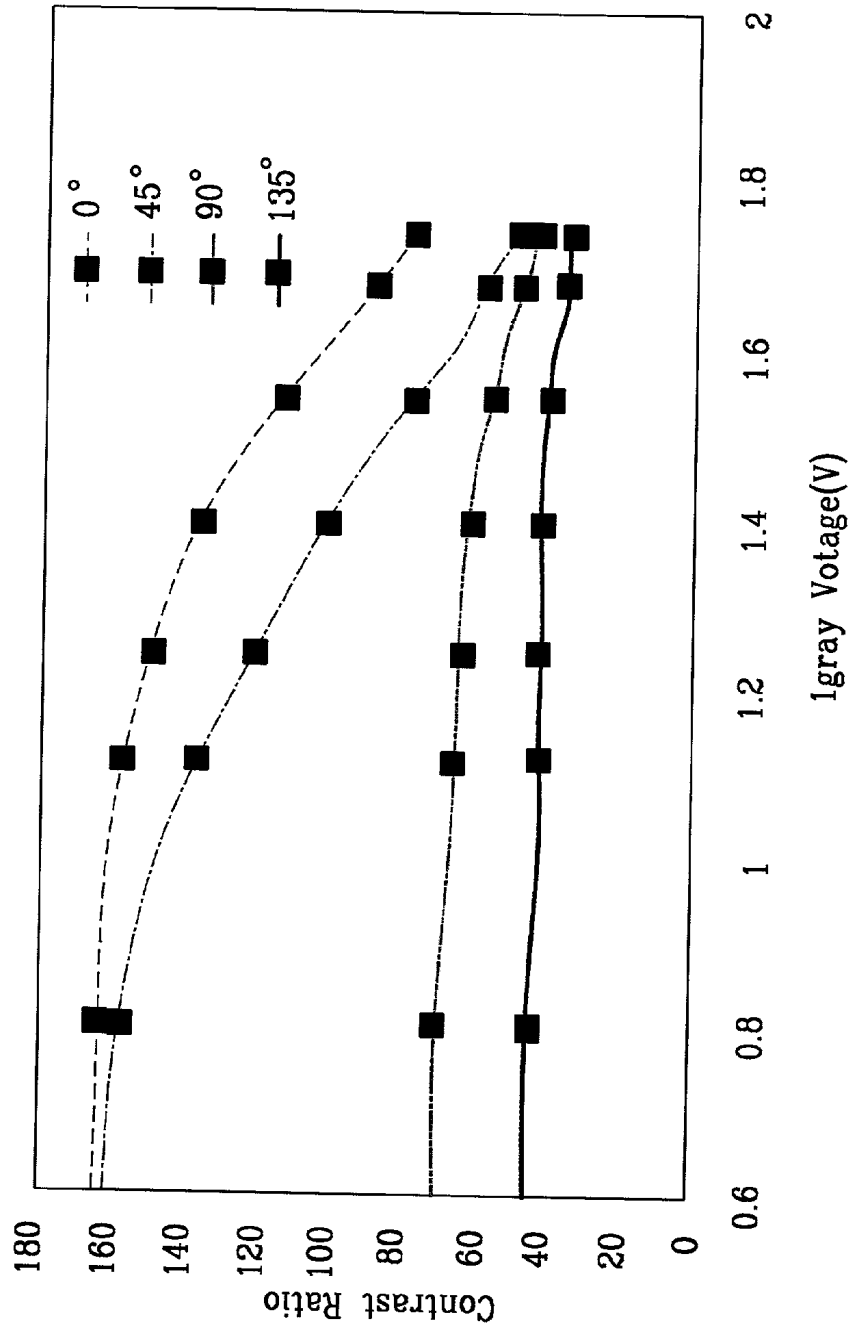

FIG.9

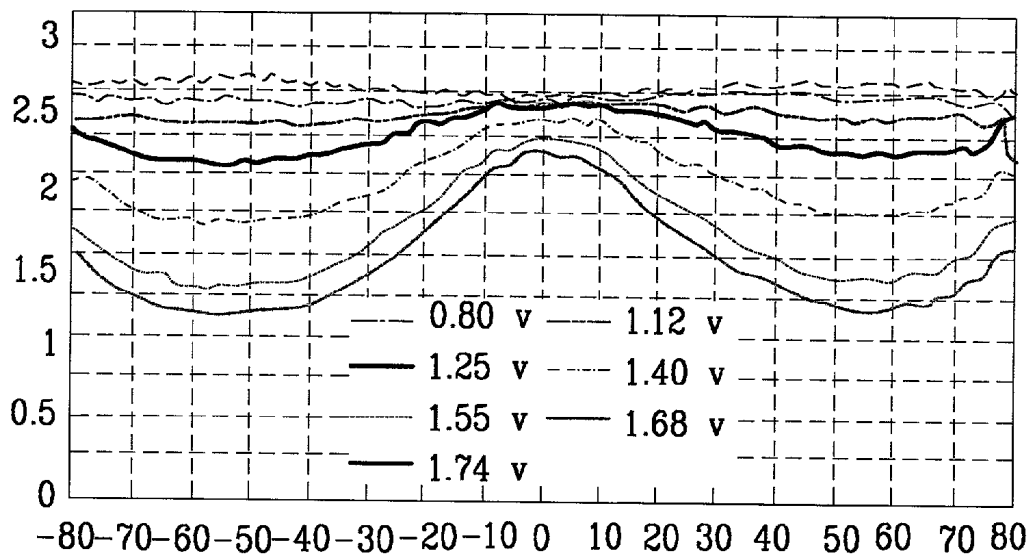

FIG.10a

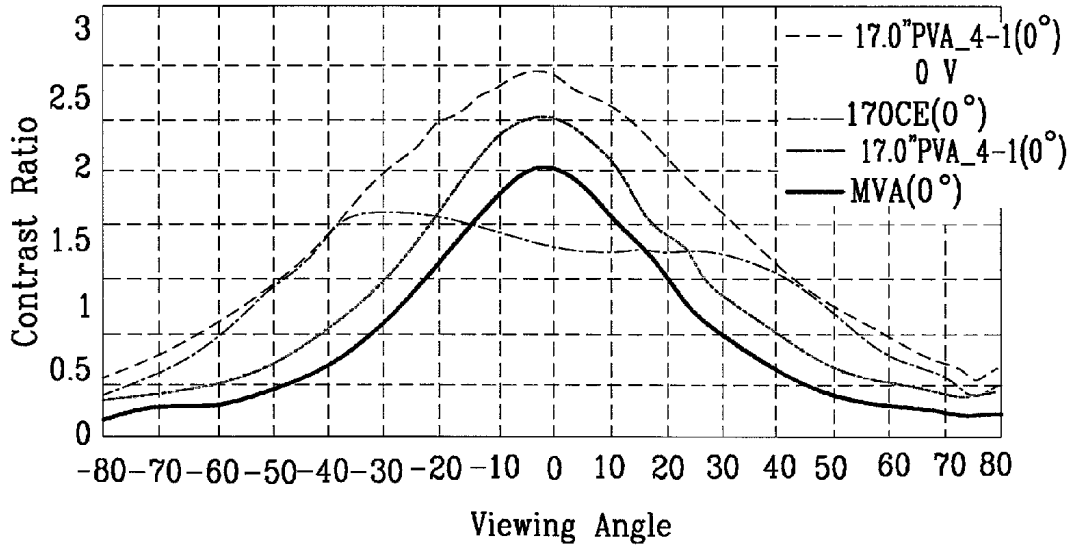

FIG.10b

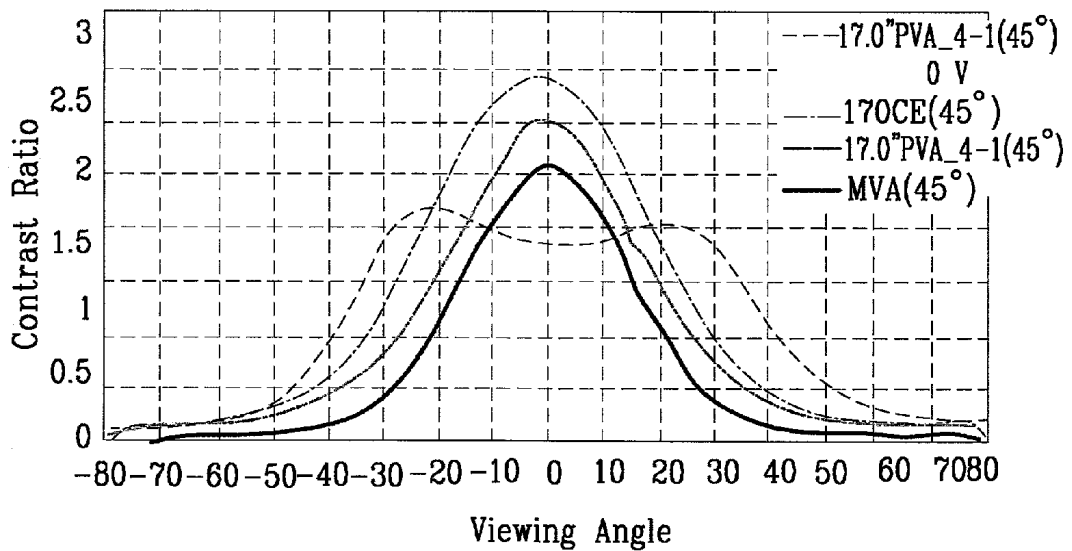

FIG.10c

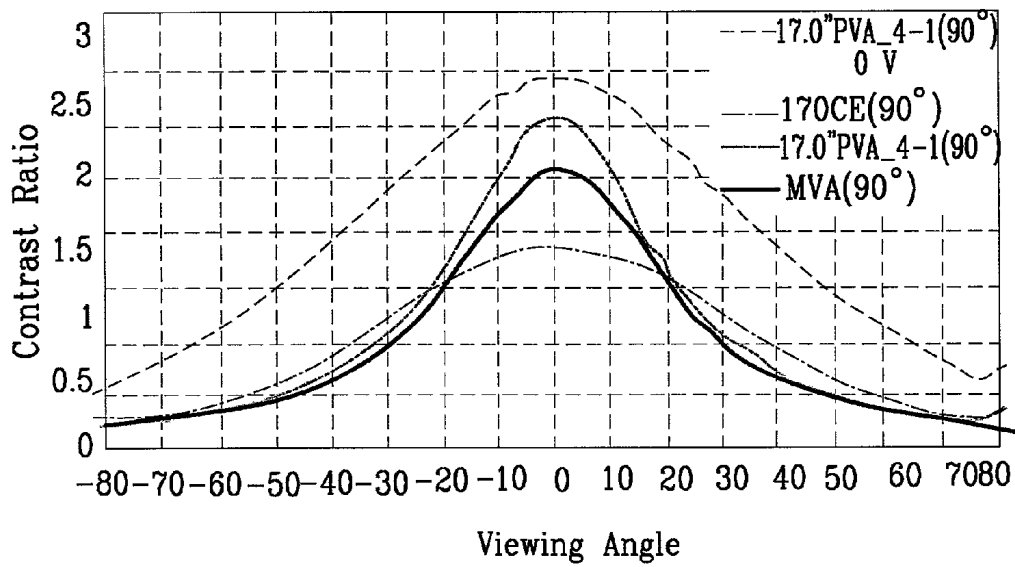

FIG.10d

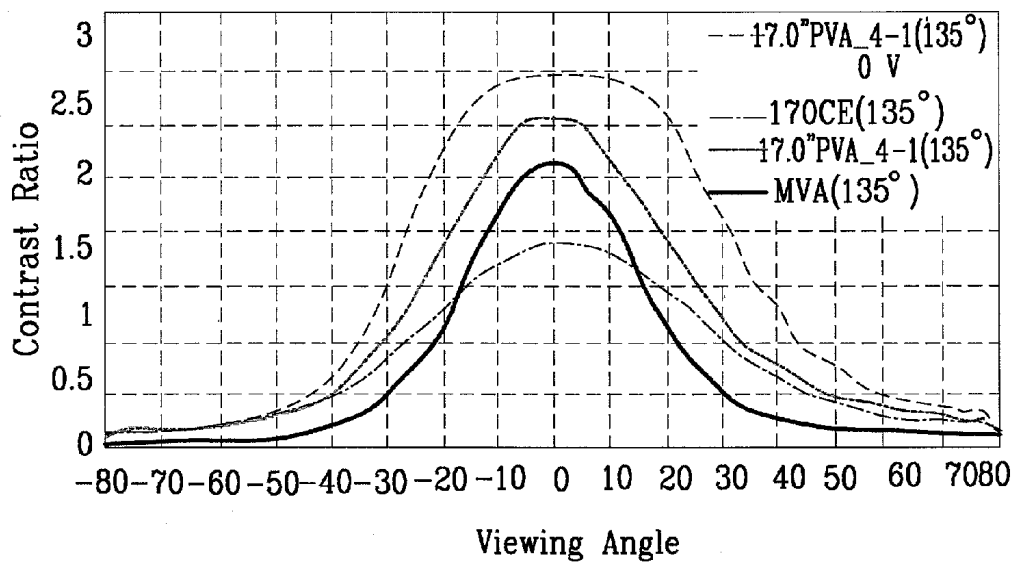

FIG.11a

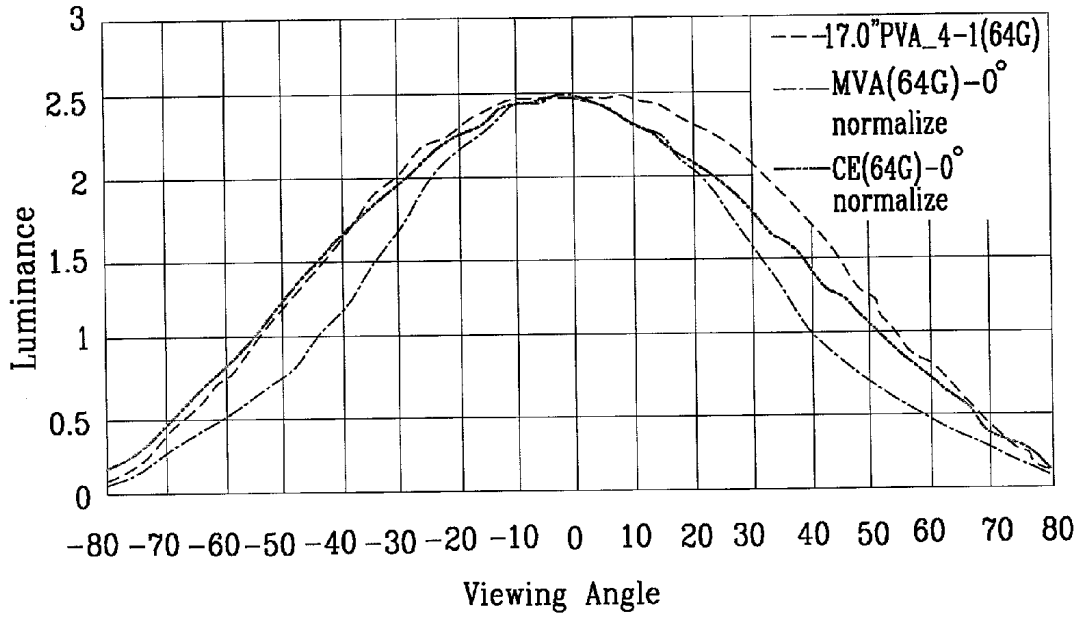

FIG.11b

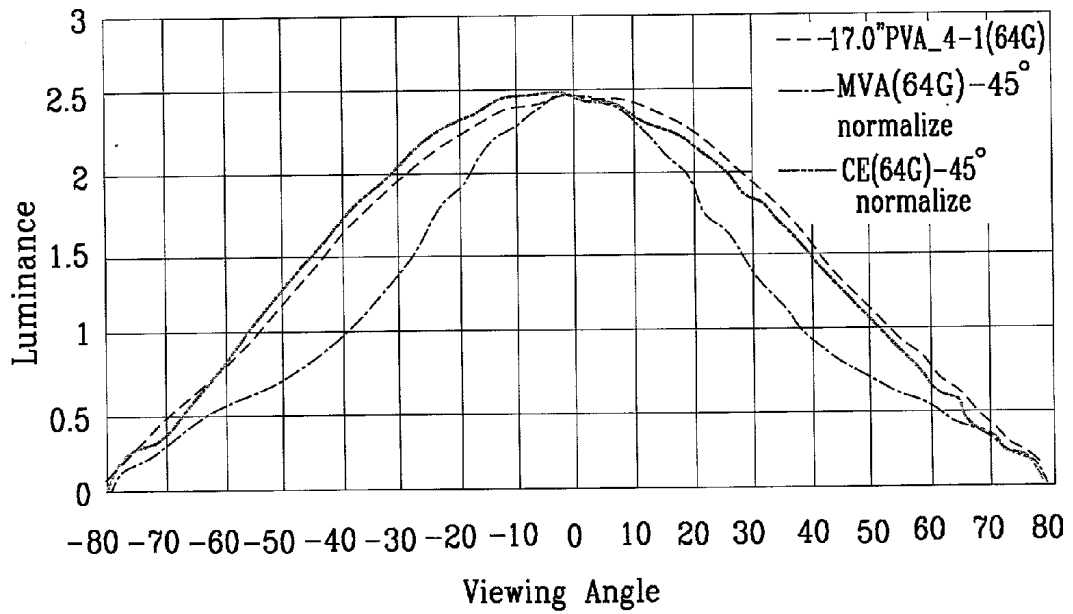

FIG.11c

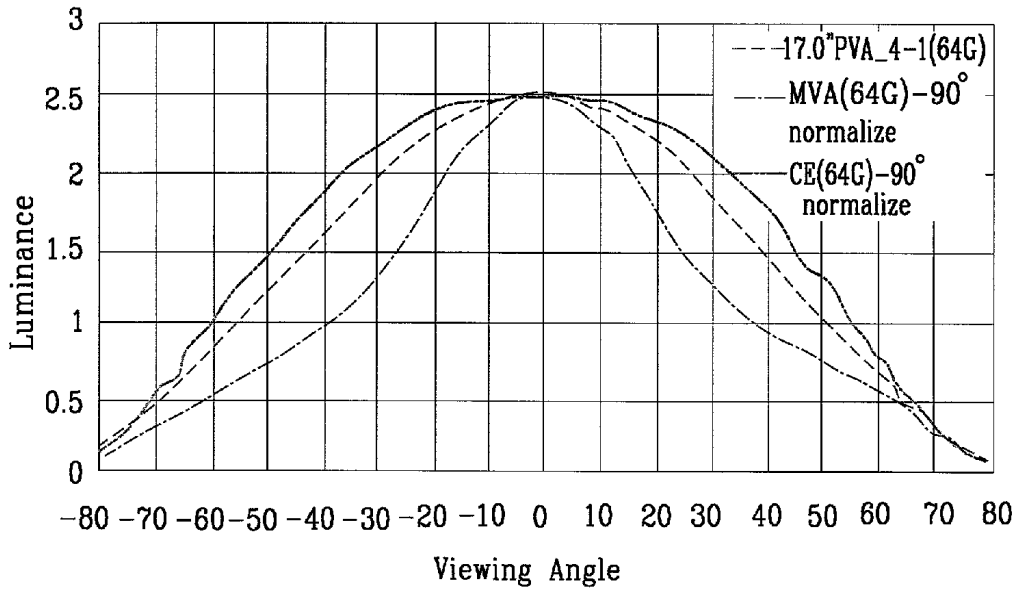

FIG.11d

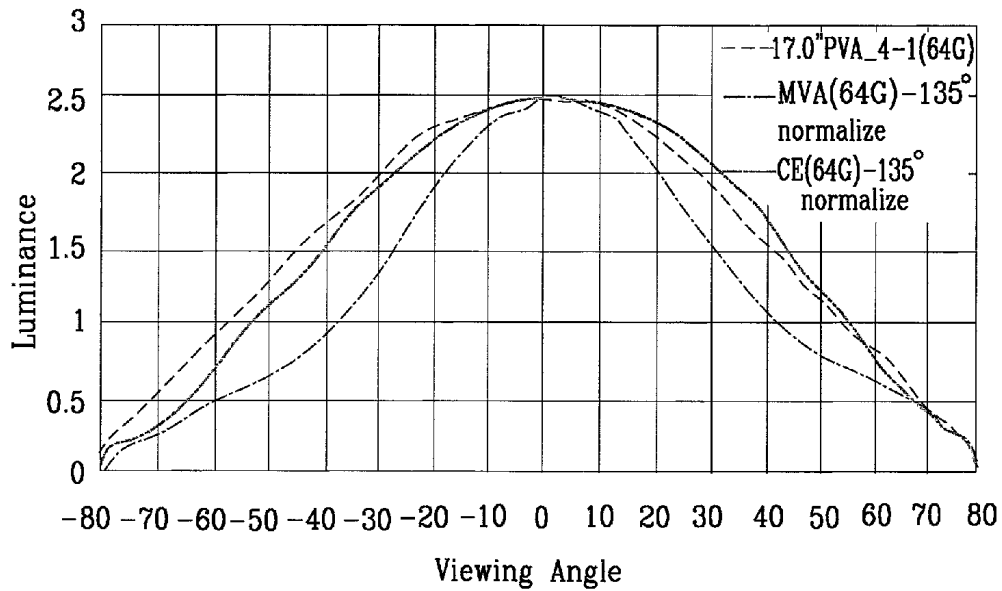

FIG.12

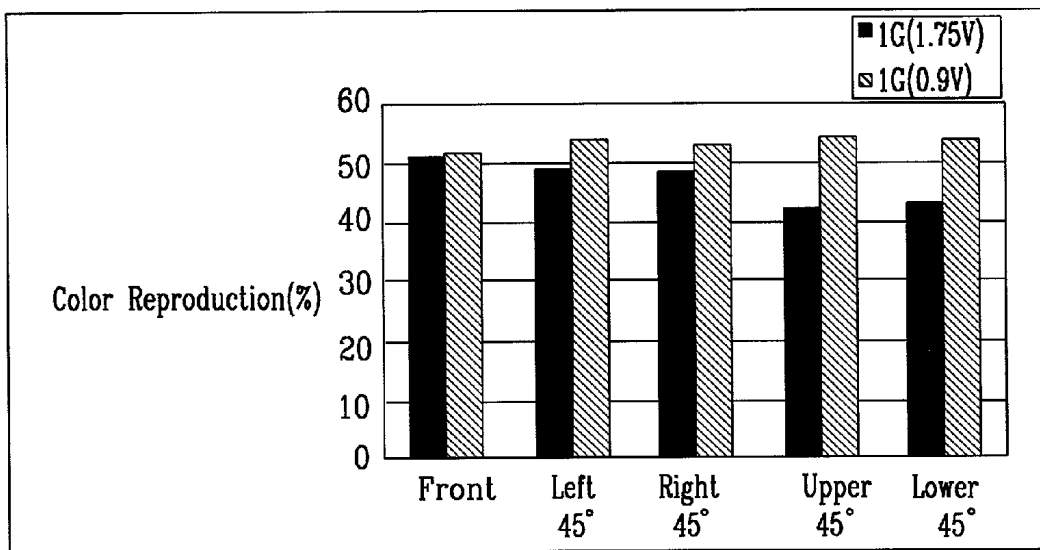

FIG.13a

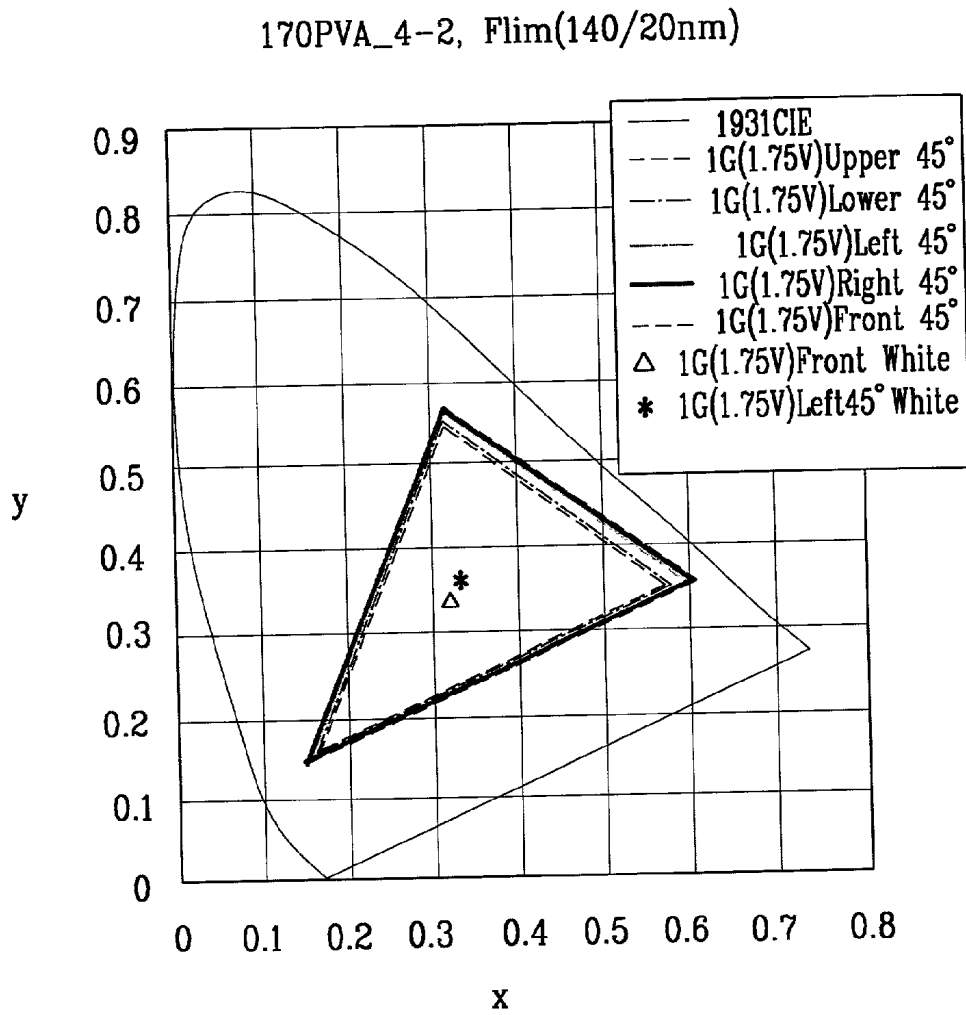
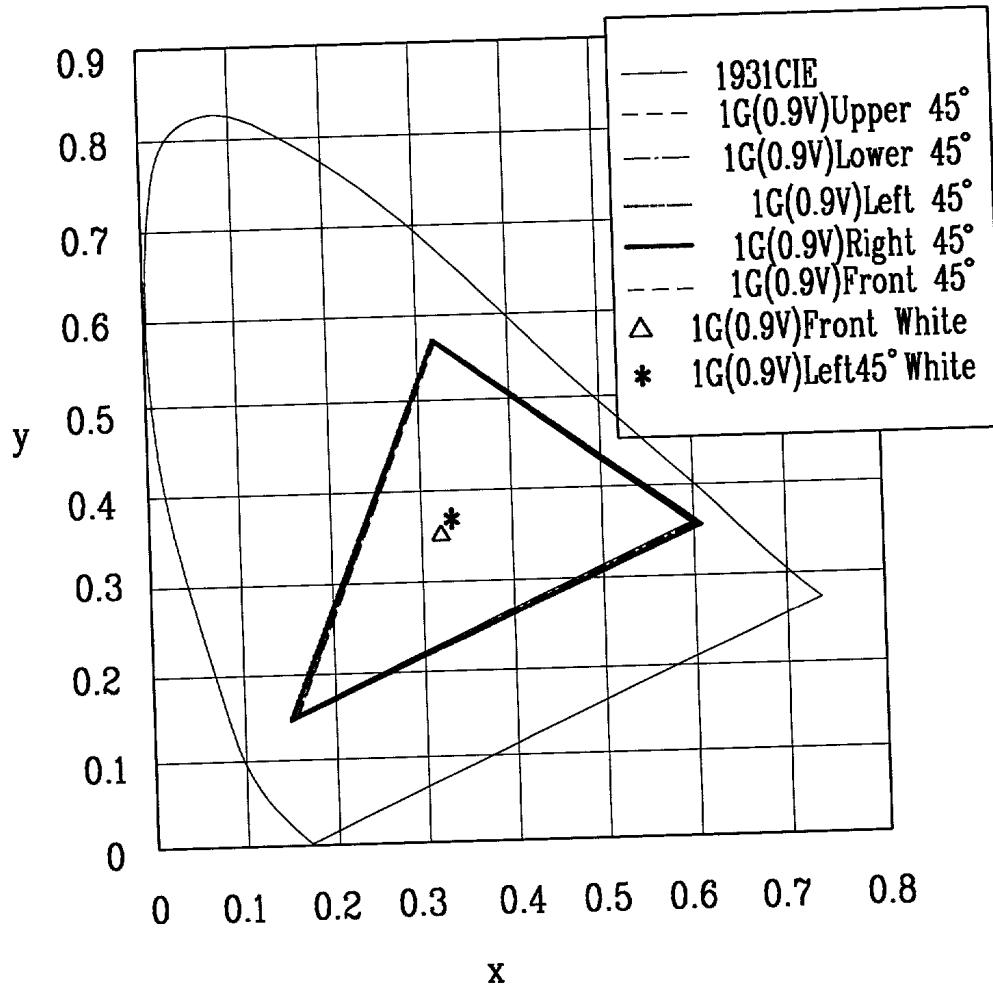

FIG.13b



**LIQUID CRYSTAL DISPLAY HAVING IMPROVED
CONTRAST RATIO AND COLOR
REPRODUCTION WHEN VIEWED IN THE
LATERAL DIRECTION**

BACKGROUND OF THE INVENTION

[0001] (a) Field of the Invention

[0002] The present invention relates to a liquid crystal display, more particularly, to a liquid crystal display having the improved image quality and viewing angle.

[0003] (b) Description of the Related Art

[0004] Generally, a liquid crystal display includes an upper panel having a common electrode and a plurality of color filters, a lower panel having pluralities of thin film transistors (TFTs) and pixel electrodes, and a liquid crystal layer between the two panels. The pixel electrodes and the common electrode are applied with different electric potentials to generate electric fields which vary the arrangement of liquid crystal molecules to control the light transmittance, thereby displaying images.

[0005] The initial arrangement of liquid crystal molecules can be, for example, horizontally twisted or vertically aligned. A vertically aligned structure can produce a relatively high contrast ratio and a relatively wide viewing angle. In a vertically aligned mode liquid crystal display, longitudinal axes of liquid crystal molecules are aligned perpendicular to the upper and the lower panels in absence of electric field. When electric field is applied, the liquid crystal molecules are tilted with respect to an axis normal to the panels at angles dependent on the strength of the electric field, so that the polarization of light passing through the liquid crystal layer can be changed. The larger the tilt angle of the liquid crystal molecules, the larger the amount of change in polarization. If the polarization axes of a polarizer and an analyzer opposite each other with respect to the liquid crystal layer are aligned to be perpendicular to each other, the light which is linearly polarized after passing through the polarizer experiences no change of the polarization in the liquid crystal layer in absence of electric field, thereby being almost completely intercepted by the analyzer. Accordingly, the screen of the liquid crystal display becomes black. However, when electric field is applied, the polarization of the linearly polarized light changes in the liquid crystal layer. Accordingly, when light reaches the analyzer, the light has a polarization component parallel to the polarization axis of the analyzer, and thus the light out of the analyzer is visible to users. Generally, the higher the strength of the electric field applied to the liquid crystal layer, the larger the magnitude of the polarization component parallel to the polarization axis of the analyzer, and the screen of the liquid crystal display becomes brighter.

[0006] Based on the above principle, a liquid crystal display realizes gray scale by adjusting the potential difference between the pixel electrodes and the common electrode. Generally, the gray scale ranges from the first gray representing the darkest state to the sixty-fourth gray representing the brightest state.

[0007] In the meantime, the contrast ratio of a liquid crystal display when viewed from its lateral sides is very poor compared with when viewed from the front of the display. The contrast ratio is defined as the luminance of the

sixty-fourth gray divided by that of the first gray. In addition, the color reproduction when viewed from the lateral sides is inferior to that of the front view. A liquid crystal display having poor contrast ratio and inferior color reproduction cannot display bright and sharp images.

SUMMARY OF THE INVENTION

[0008] It is an object of the present invention to improve the contrast ratio of a liquid crystal display when viewed from the lateral sides.

[0009] It is another object of the present invention to improve the color reproduction of a liquid crystal display when viewed from the lateral sides.

[0010] It is still another object of the present invention to improve the image quality of a liquid crystal display when viewed from the lateral sides.

[0011] These and other objects are achieved by restricting the maximum value of the first gray voltage of a liquid crystal display to a predetermined value.

[0012] According to one aspect of the present invention, a liquid crystal display includes a first panel having inner and outer surfaces and a second panel facing the first panel and having inner and outer surfaces. A plurality of pixel electrodes and a common electrode are provided on one of the inner surfaces of the first and the second panels. A liquid crystal layer is disposed between the first and the second panels. Voltage value of a first gray representing the darkest state applied between the pixel electrode and the common electrode is within a voltage range giving a contrast ratio to be equal to or higher than about 0.8 with respect to contrast ratio when the voltage applied between the pixel electrode and the common electrode is zero. A pair of crossing polarizers are disposed on the outer surfaces of the first and the second panels and the liquid crystal layer is vertically aligned in absence of electric field. Domain-defining member for restricting the tilt directions of molecules in the liquid crystal layer is provided in one or both of the first and the second panels. The domain-defining member is openings in the pixel electrode or the common electrode. In this case, the voltage value of the first gray is equal to or lower than 1.4 V. Regions divided by the openings are classified into four domains depending on the tilt directions of the liquid crystal molecules.

BRIEF DESCRIPTION OF THE DRAWINGS

[0013] A more complete appreciation of the invention, and many of the attendant advantages thereof, will be readily apparent as the same becomes better understood by reference to the following detailed description when considered in conjunction with the accompanying drawings in which like reference symbols indicate the same or the similar components, wherein:

[0014] **FIG. 1A** is a sectional view of a liquid crystal display according to an embodiment of the present invention;

[0015] **FIG. 1B** is a schematic layout view illustrating the overlap between openings of a pixel electrode and apertures of a common electrode of a liquid crystal display according to the first embodiment of the present invention;

[0016] FIG. 2 is a layout view illustrating the overlap between the openings of a pixel electrodes and apertures of a common electrode of a liquid crystal display according to the second embodiment of the present invention;

[0017] FIGS. 3A to 3D are graphs illustrating contrast ratios as a function of the viewing angle θ for azimuthal angles Φ of 0°, 45°, 90° and 135°, respectively, when the applied first gray voltage is 0 volt (a) and 1.7 volts (b);

[0018] FIGS. 4A to 4D are graphs illustrating the luminance as a function of the viewing angle θ for azimuthal angles Φ of 0°, 45°, 90° and 135°, respectively, when the applied first gray voltage is 0 volt (a) and 1.7 volts (b);

[0019] FIGS. 5A and 5B show a lateral view in one polarizing direction and a front view of a liquid crystal display, respectively, when liquid crystal molecules tilt in the other polarizing direction;

[0020] FIGS. 5C and 5D show a lateral view in the tilt direction of liquid crystal molecules and a front view of a liquid crystal display, respectively, when the tilt direction of the liquid crystal molecules makes 45 degrees with both polarizing direction;

[0021] FIGS. 6A to 6D are graphs illustrating the luminance as a function of the viewing angle θ for the various voltages of the first gray when the azimuthal angles Φ are 0°, 45°, 90° and 135°, respectively;

[0022] FIGS. 7A to 7D are graphs illustrating the contrast ratio as a function of the viewing angle θ for the various voltages of the first gray when the azimuthal angles Φ are 0°, 45°, 90° and 135°, respectively;

[0023] FIG. 8 is a graph illustrating the contrast ratio as a function of the first voltage for various azimuthal angles when the viewing angle θ is 45°;

[0024] FIG. 9 is a graph illustrating the contrast ratio as a function of the viewing angle for the various voltages of the first gray with reference to the contrast ratio of 0 volt being applied;

[0025] FIGS. 10A to 10D are graphs showing the contrast ratio of the first embodiment of the present invention as a function of the viewing angle θ along with those of the conventional PVA (Patterned Vertical Aligned), MVA (Multi-domain Vertical Aligned) and CE (coplanar electrode) mode LCDs when the azimuthal angles Φ are 0°, 45°, 90° and 135°, respectively;

[0026] FIGS. 11A to 11D are graphs showing the luminance of the first embodiment of the present invention as a function of the viewing angle θ along with those of the conventional PVA, MVA and CE mode LCDs when the azimuthal angles Φ are 0°, 45°, 90° and 135°, respectively;

[0027] FIG. 12 is a graph illustrating the color reproductions in the front view and the side views ($\theta=45^\circ$) for the first gray voltages of 1.75 volts and 0.9 volts; and

[0028] FIGS. 13A and 13B are color-coordinate diagram for the first gray voltages of 1.75 volts and 0.9 volts.

DETAILED DESCRIPTION OF THE PREFERRED EMBODIMENTS

[0029] The present invention now will be described more fully hereinafter with reference to the accompanying draw-

ings, in which preferred embodiments of the invention are shown. This invention may, however, be embodied in many different forms and should not be construed as limited to the embodiments set forth herein. In the drawings, the thickness of layers and regions are exaggerated for clarity. Like numerals refer to like elements throughout. It will be understood that when an element such as a layer, region or substrate is referred to as being "on" another element, it can be directly on the other element or intervening elements may also be present. In contrast, when an element is referred to as being "directly on" another element, there are no intervening elements present.

[0030] FIG. 1A is a sectional view of a liquid crystal display according to an embodiment of the present invention, and FIG. 1B is a schematic layout view illustrating the overlap between a pixel electrode and apertures of a common electrode of a liquid crystal display according to the first embodiment of the present invention.

[0031] A liquid crystal display according to this embodiment includes a lower panel 1, an upper panel 2 facing the lower panel 1, and liquid crystal molecules 30 vertically aligned between the lower and the upper panels 1 and 2.

[0032] A plurality of rectangular pixel electrodes 12 of transparent conductive material having openings are provided on the inner surface of a lower substrate 10 of transparent insulating material such as glass. Each pixel electrode 12 is connected to a respective switching element 11 such as a thin film transistor to be applied with image signals via the switching element 11. The switching element 11 is connected to both a gate line (not shown) transmitting scanning signals and a data line (not shown) transmitting image signals, and turned on/off responsive to the scanning signal to transmit the image signals to the respective pixel electrode 12. In addition, a lower polarizer 14 is attached to the outer surface of the lower substrate 10. In a reflective type liquid crystal display, the lower substrate 10 and the pixel electrodes 12 may be made of opaque material. In this case, the lower polarizer 14 is not required.

[0033] A black matrix 21 for preventing light leakage, a plurality of color filters 22 and a common electrode 23 of transparent conductive material such as ITO (Indium-Tin Oxide) or IZO (Indium-Zinc Oxide) having apertures are provided on the inner surface of an upper substrate 20 of transparent insulating material such as glass. The black matrix 21 or the color filters 22 may be provided on the lower substrate 10. In addition, an upper polarizer 24 is attached to the outer surface of the upper substrate 20.

[0034] The liquid crystal display according to this embodiment is in the normally black mode, where the polarizing directions of the lower and the upper polarizers 14 and 24 are aligned perpendicular to each other, and the screen becomes dark as the electric field generated by the pixel electrode and the common electrode to be applied to the liquid crystal molecules is reduced.

[0035] In this liquid crystal display, the apertures and the openings of the common electrode 23 and the pixel electrodes 12 are used for restricting the tilt directions of the liquid crystal molecules. The shapes and arrangement of the openings and the apertures according to the present invention will be described in detail.

[0036] As shown in FIG. 1B, there are provided three openings 122, 121 and 123 in the rectangular pixel electrode

12, which are arranged in a longitudinal direction. A middle opening **121** extends in a transverse direction from the right side of the pixel electrode **12** toward the left side. The corners of the pixel electrode **12** near the inlet of the middle opening **121** are chamfered at a smooth angle to be curved. Upper and lower openings **122** and **123** are provided in upper and lower portions of the pixel electrode **12** opposed to each other with respect to the middle opening **121**. Each of the upper and the lower openings **122** and **123** starts at a proximal corner of the pixel electrode **12**, away from the middle opening **121**, and continues toward the middle opening **121** in a diagonal direction. In this embodiment, the upper and the lower openings **122** and **123** are symmetrical with respect to the middle opening **121**.

[0037] The common electrode **23** includes three apertures **220**, **210** and **230** arranged in the longitudinal direction. A middle aperture **210** has a stem **211** extending from the left side in the transverse direction, upper and lower oblique branches **212** and **214** extending from the end of the stem **211** obliquely upward and downward, respectively, and upper and lower longitudinal branches **213** and **215** extending from the ends of the upper and the lower oblique branches **212** and **214**, respectively. The upper branch **212** is nearly perpendicular to the lower branch **214**. An upper aperture **220** has a middle portion **221** extending parallel to the upper oblique branch **212**, and transverse and longitudinal portion **222** and **223** extending from upper and lower ends of the middle portion **221** in the transverse and the longitudinal directions, respectively. The lower aperture **230** and the upper aperture **220** are symmetrically arranged with respect to middle aperture **210**. That is, a middle portion **231** of the lower aperture **230** is arranged parallel to the lower oblique branch **214** of the middle aperture **210**, and longitudinal and transverse portion **233** and **232** extends from the upper and the lower ends of the middle portion **231** in the longitudinal and the transverse directions, respectively. Such arrangement of the apertures **210**, **220** and **230** is provided repeatedly on the common electrode **23**.

[0038] The openings **121**, **122** and **123** of the pixel electrode **12** and the apertures **210**, **220** and **230** of the common electrode **23** divide the pixel electrode **12** into a plurality of areas to define domains. The openings **121**, **122** and **123** of the pixel electrode **12** and the apertures **210**, **220** and **230** of the common electrode **23** are alternately arranged. The openings **122** and **123** are parallel to the middle portions **221** and **231** as well as the oblique branches **212** and **214**, respectively. These oblique openings **122** and **123**, and portions **221** and **231**, and branches **212** and **214** of the apertures **210**, **220** and **230** form long edges of the areas, while the opening **121**, the portions **222**, **223**, **232** and **233**, the stem **211** and the branches **213** and **215** in the longitudinal or transverse directions form short edges of the areas.

[0039] The polarizing directions of the upper and the lower polarizers **14** and **24** are aligned in the transverse and the longitudinal directions, respectively, or vice versa.

[0040] In this structure, since most of the liquid crystal molecules applied with electric fields tend to tilt in the direction perpendicular to the long edges, there are four different average tilt directions to form four domains which generate wide viewing angle, and the number of the liquid crystal molecules tilting in the polarizing direction of the polarizers **14** and **24** decreases to reduce texture. In addition,

since the arrangement of the liquid crystal molecules may be completed nearly immediately, the response time is very short.

[0041] The second embodiment of the present invention will be described with the accompanying drawings.

[0042] FIG. 2 is a layout view illustrating openings of a pixel electrode and apertures of a common electrode of a liquid crystal display according to the second embodiment of the present invention. The structure of the second embodiment is similar to that of the first embodiment except for the shapes of the openings and apertures.

[0043] The pixel electrode **12** includes a longitudinal opening **111** and three transverse openings **120**, **130** and **140** arranged along the longitudinal direction. The longitudinal opening **111** extends downward from the upper edge of the pixel electrode **12**, and divides the upper portion of the pixel electrode **12** into two partitions arranged in the transverse direction. The transverse openings **120**, **130** and **140** extend leftward from the right edge of the pixel electrode **12**, and divide the lower portion of the pixel electrode **12** into four partitions arranged along the longitudinal direction.

[0044] The common electrode **23** includes an upper aperture **210** having two longitudinal portions **212** and **214** and a transverse portion **216** connected thereto, and three lower transverse apertures **230**, **240** and **250**, and the upper and the lower apertures **210**, **230**, **240** and **250** are laterally arranged along the longitudinal direction.

[0045] Each of the two longitudinal portions **212** and **214** divides the respective upper partition into two areas, thereby forming four upper areas. The upper two **230** and **240** of the lower apertures **230**, **240** and **250** divide the middle two of the lower partitions of the pixel electrodes **12**, and the transverse portion **216** of the upper aperture **210** and the lowest aperture **250** form the upper and the lower edges of the lower portion of the pixel electrode **12**.

[0046] The voltage of the first gray representing the darkest state in a liquid crystal display is confined in a range and this will be described in detail.

[0047] According to a preferred embodiment of the present invention, the voltage of the first gray is determined in a voltage range which gives the contrast ratio to be equal to or larger than about 0.8 in all viewing directions when compared to contrast ratio when applying 0 volt. The voltage range depends on the type of the liquid crystal panel. In the LCD according to the embodiments wherein the liquid crystal molecules are arranged vertical to the upper and the lower panels and the openings and the apertures are provided on both the pixel electrode and the common electrode, the voltage range of the first gray is within 0 volt to 1.4 volts. The reason for the limitation of the voltage range of the first gray will be described below.

[0048] Advantageously, lateral contrast ratio and lateral color reproduction of the liquid crystal display are largely improved.

[0049] FIGS. 3A to 3D are graphs illustrating contrast ratios as a function of the viewing angle θ for azimuthal angles Φ of 0° , 45° , 90° and 135° , respectively. The two curves are those when the applied first gray voltage is 0 volt (a) and 1.7 volts (b).

[0050] The voltage of 1.7 volts was chosen because the voltage of 1.7 volts is less than the threshold voltage where the transmittance starts increasing in the V-T (voltage-transmittance) curve measured in front of a liquid crystal display and because this voltage gives suitable voltage gaps between this voltage and the successive second and third gray voltages.

[0051] As shown in FIGS. 3A to 3D, it is apparent that the contrast ratio of 0 volt is better than that of 1.7 volts in all viewing angles.

[0052] FIGS. 4A to 4D are graphs illustrating the luminance as a function of the viewing angle θ for azimuthal angles Φ of 0°, 45°, 90° and 135°, respectively. The two curves are those when the applied first gray voltage is 0 volt (a) and 1.7 volts (b).

[0053] As shown in FIGS. 4A to 4D, it is apparent that the luminance of 1.7 volts is higher than that of 0 volt in all viewing angles. High luminance in the first gray representing the darkest state means high light leakage in the black state.

[0054] For azimuthal angles of 0° and 90°, the luminance curve of 1.7 volts exhibits high peaks near $\pm 50^\circ$ while that of 0 volt showing no peak. For azimuthal angles of 45° and 135°, both the luminance curves of 0 volt and 1.7 volts show high peaks, but the luminance of 1.7 volts is still larger than that of 0 volt. This high luminance of 1.7 volts may result in high contrast.

[0055] FIGS. 5A to 5D show liquid crystal molecules applied with a voltage of 1.7 volts. FIGS. 5A and 5B are lateral views in one polarizing direction and a front view of a liquid crystal display, respectively, when liquid crystal molecules tilt in the other polarizing direction. FIGS. 5C and 5D are lateral views in the tilt direction of liquid crystal molecules and a front view of a liquid crystal display, respectively, when the tilt direction of the liquid crystal molecules makes 45 degrees with both polarizing direction.

[0056] Although the threshold voltage of a liquid crystal display is higher than 1.7 volts, the liquid crystal molecules are minutely moved. The retardation in the lateral view is large compared with that in the front view, as shown in FIGS. 5A to 5D. Accordingly, the brightness in the front view is low while that in the lateral view is relatively high. In addition, the retardation variation in the lateral view when the tilt direction makes 45 degrees with the polarizing directions is smaller than that when the tilt direction is parallel to the polarizing direction, as shown in FIGS. 5A and 5C, and this causes small contrast variation.

[0057] FIGS. 6A to 6D are graphs illustrating the luminance as a function of the viewing angle θ for various voltages of the first gray when the azimuthal angles Φ are 0°, 45°, 90° and 135°, respectively, and FIGS. 7A to 7D are graphs illustrating the contrast ratio as function of the viewing angle θ for various voltages of the first gray when azimuthal angles Φ are 0°, 45°, 90° and 135°, respectively.

[0058] As the first gray voltage decreases, the luminance decreases while the contrast ratio increases. The contrast ratio curve of the applied voltage of 0.8 volts shows the same as that of zero voltage.

[0059] FIG. 8 is a graph illustrating the contrast ratio as a function of the applied voltage for several azimuthal angles

when the viewing angle θ is 45°. As shown in FIG. 8, contrast ratio increases as the applied voltage decreases for all azimuthal angles.

[0060] FIG. 9 is a graph illustrating the contrast ratio of a PVA (Patterned Vertically Aligned) LCD in the polarizing direction as a function of the viewing angle for various applied voltages with reference to that of zero volt.

[0061] As shown in FIG. 9, the variation of the contrast ratio depending on the viewing angle becomes larger as the applied voltage becomes higher. It is understood that the applied voltage equal to or smaller than 1.4 volts gives the contrast ratio equal to or higher than 0.8 in all viewing directions. However, this value may be varied depending on the type of LCD or the kind of liquid crystal material.

[0062] The light leakage is larger in the diagonal direction than in the polarizing direction even when applying 0 volt as the first gray voltage, and this may be compensated by adjusting the retardation value of a phase compensation film or changing a cell gap.

[0063] In order to review the effect of the present invention, the contrast ratio and the luminance of the white color of an LCD according to the present invention were compared with those of conventional liquid crystal displays.

[0064] FIGS. 10A to 10D are graphs showing contrast ratio as a function of the viewing angle θ for an LCD according to the first embodiment of the present invention, and conventional PVA, MVA (Multi-domain Vertically Aligned) and CE (Coplanar Electrode) mode LCDs, when the azimuthal angles Φ are 0°, 45°, 90° and 135°, respectively.

[0065] FIGS. 11A to 11D are graphs showing the luminance as a function of the viewing angle θ for an LCD according to the first embodiment of the present invention, and conventional PVA, MVA and CE mode LCDs when the azimuthal angles Φ are 0°, 45°, 90° and 135°, respectively.

[0066] A PVA mode LCD is a vertically aligned mode LCD having openings as domain-defining members, an MVA mode LCD is also a vertically aligned mode LCD but having projections as domain-defining members, and a CE mode LCD has pixel electrodes and a common electrode provided in the same panel.

[0067] As shown in FIGS. 10A to 10D, the contrast ratio of the liquid crystal display according to the embodiment of the present invention is superior in all viewing angles except for the case of the azimuthal angle of 45 degrees shown in FIG. 10B.

[0068] As shown in FIGS. 11A to 11D, the luminance of the white color of the liquid crystal display according to the embodiment of the present invention is superior to the MVA mode and is similar or slightly superior to the CE mode.

[0069] Next, the color reproduction will be described.

[0070] FIG. 12 and Table 1 illustrate the color reproductions in the front view and the lateral views ($\theta=45^\circ$) when the applied voltage is 1.75 volts and 0.9 volts.

TABLE 1

First Gray Voltage	Front	Left 45°	Right 45°	Top 45°	Bottom 45°
1.75 V	51.3	49.2	48.2	42.0	42.8
0.9 V	51.8	53.8	52.9	54.1	53.5

[0071] As shown in Table 1 and FIG. 12, the color reproduction of 1.75 volts is similar to that of 0.9 volts in the front view, while severely deteriorated in the lateral view. This can be understood in the same manner as the decrease of the contrast ratio and the increase of luminance in the lateral view, as described above. For example, when blue color is intended to display, the red and the green pixels are applied with the first gray voltage to be dark and only the blue pixel is applied with higher gray voltage to be brightened. However, leaked light in the red and the green pixels applied with the first gray voltage is mixed to distort the display of pure blue color.

[0072] FIGS. 13A and 13B are color-coordinate graphs when the first gray voltage is 1.75 volts and 0.9 volts, respectively.

[0073] As described above, when displaying the blue color, the light leakages in the red and the green pixels make color-coordinate to move toward the white color. In this way, when displaying the red or the green color, the light leakages in the other color pixels also make color-coordinate to move toward the white color, thereby diminishing the size of a triangle connecting the red, the green and the blue colors. The decreases of the size of the triangle connecting the red, the green and the blue color means that displayable color range is small, thereby color reproduction is deteriorated.

[0074] Accordingly, to improve color reproduction, the first gray voltage should be smaller than a value as taught by the present invention.

[0075] As described above, the contrast ratio and the color reproduction can be improved by lowering the first gray voltage, so that the image quality of a liquid crystal display is improved.

[0076] While the present invention has been described in detail with reference to the preferred embodiments, those skilled in the art will appreciate that various modifications and substitutions can be made thereto without departing from the spirit and scope of the present invention as set forth in the appended claims.

What is claimed is:

1. A liquid crystal display comprising:
 - a first panel having inner and outer surfaces;
 - a second panel facing the first panel and having inner and outer surfaces;
 - a pixel electrode provided on the inner surface of the first panel;
 - a common electrode provided on the inner surface of the second panel; and
 - a liquid crystal layer between the first and the second panels,

wherein voltage value of a first gray representing the darkest state applied between the pixel electrode and the common electrode is within a voltage range giving a contrast ratio to be equal to or higher than about 0.8 with respect to contrast ratio when the voltage applied between the pixel electrode and the common electrode is zero.

2. The liquid crystal display of claim 1 further comprising a first and second polarizers disposed on respective outer surfaces of the first and the second panels.

3. The liquid crystal display of claim 2, wherein the liquid crystal layer is vertically aligned in absence of electric field.

4. The liquid crystal display of claim 3 further comprising domain-defining member for restricting the tilt directions of molecules in the liquid crystal layer, provided in one or both of the first and the second panels.

5. The liquid crystal display of claim 4, wherein the domain-defining member is openings in the pixel electrode or the common electrode.

6. The liquid crystal display of claim 5, wherein the voltage value of the first gray is equal to or lower than 1.4 V.

7. The liquid crystal display of claim 6, wherein the openings are provided in both the pixel electrode and the common electrode.

8. The liquid crystal display of claim 7, wherein regions divided by the openings are classified into four domains depending on the tilt directions of the liquid crystal molecules.

9. A liquid crystal display comprising:

a first and second panel, each having inner and outer surfaces, with inner surfaces facing each other;

a common electrode disposed on the inner surface of the first panel and a common electrode disposed on the inner surface of the second panel; and

a liquid crystal layer having crystal molecules disposed between the first and second panels, wherein a domain defining member is formed in one of the common electrode and the pixel electrode for restricting the tilt directions of the crystal molecules.

10. The display according to claim 9, wherein the domain defining member includes an upper opening, middle opening and a lower opening arranged laterally along a longitudinal direction, the upper and lower openings being symmetrically spaced with respect to the middle opening.

11. The display according to claim 10, wherein each of the upper and lower openings includes a slant portion which slants toward the middle opening.

12. The display according to claim 10, wherein the domain defining member further includes upper, lower, and middle apertures, the upper and lower apertures having the same shape and are disposed symmetrically about the middle aperture.

13. The display according to claim 12, wherein each of the apertures includes at least one slant portion, the slant portion in the upper and lower apertures slanting in a parallel direction with respect to one of two slants in the middle aperture.

14. The display according to claim 9, wherein the domain defining member includes a plurality of openings arranged laterally along a longitudinal direction, with at least one opening disposed in a direction transverse to the longitudinal direction.

专利名称(译)	当在横向方向上观察时，液晶显示器具有改善的对比度和颜色再现		
公开(公告)号	US20020113931A1	公开(公告)日	2002-08-22
申请号	US09/992474	申请日	2001-11-14
[标]申请(专利权)人(译)	朴升BEOM KIM KYEONG铉		
申请(专利权)人(译)	朴升BEOM KIM KYEONG铉		
当前申请(专利权)人(译)	朴升BEOM KIM KYEONG铉		
[标]发明人	PARK SEUNG BEOM KIM KYEONG HYEON		
发明人	PARK, SEUNG-BEOM KIM, KYEONG-HYEON		
IPC分类号	G02F1/1337 G02F1/133 G02F1/1333 G02F1/1335 G02F1/1343 G02F1/139		
CPC分类号	G02F1/133707 G02F1/1393 G02F2201/121		
优先权	1020000067391 2000-11-14 KR		
其他公开文献	US6970220		
外部链接	Espacenet USPTO		

摘要(译)

具有开口和薄膜晶体管的多个像素电极设置在下面板上，具有孔的公共电极设置在上面板上，垂直对准两个面板的液晶层位于下面板和上面板之间。具有垂直偏振方向的上偏振器和下偏振器分别设置在上板和下板的外表面上。表示在像素电极和公共电极之间施加的最暗状态的第一灰度的电压值在相对于像素电极之间施加的电压时的对比度给出对比度等于或高于0.8的电压范围内。公共电极为零。这样，提高了对比度和色彩再现，从而提高了液晶显示器的图像质量。

