



US007986383B2

(12) **United States Patent**
Han et al.

(10) **Patent No.:** **US 7,986,383 B2**
(45) **Date of Patent:** **Jul. 26, 2011**

(54) **LIQUID CRYSTAL DISPLAY DEVICE
HAVING IMPROVED LIGHT GUIDE PLATE**

(58) **Field of Classification Search** 349/62-67
See application file for complete search history.

(75) Inventors: **Byung-Woong Han**, Incheon (KR);
Dong-Cheol Kim, Suwon-si (KR);
Kyu-Seok Kim, Yongin-si (KR);
Jeong-Min Seo, Seongnam-si (KR);
Young-Bee Chu, Suwon-si (KR);
Sang-Min Yi, Suwon-si (KR)

(56) **References Cited**

U.S. PATENT DOCUMENTS

6,976,779	B2 *	12/2005	Ohtsuki et al.	362/608
7,056,005	B2 *	6/2006	Lee	362/625
7,478,937	B2 *	1/2009	Hara et al.	362/606
2005/0180166	A1 *	8/2005	Hara et al.	362/606

FOREIGN PATENT DOCUMENTS

CN	1553226	A	12/2004
CN	2690915		4/2005
JP	2006-240275		4/2005
KR	10-0425511		3/2004
KR	10-0499140		6/2005
WO	2006/098479		9/2006

* cited by examiner

(73) Assignee: **Samsung Electronics Co., Ltd.** (KR)

(*) Notice: Subject to any disclaimer, the term of this patent is extended or adjusted under 35 U.S.C. 154(b) by 277 days.

Primary Examiner — Kevin S Wood

(21) Appl. No.: **11/931,928**

(22) Filed: **Oct. 31, 2007**

(74) *Attorney, Agent, or Firm* — Innovation Counsel LLP

(65) **Prior Publication Data**

US 2008/0129925 A1 Jun. 5, 2008

(30) **Foreign Application Priority Data**

Dec. 4, 2006 (KR) 10-2006-0121533

(57) **ABSTRACT**

A backlight assembly for an LCD device having a light guide plate that includes at least two thin layers and a plurality of optical sheets sequentially stacked over the rear surface of the liquid crystal panel.

(51) **Int. Cl.**
G02F 1/1335 (2006.01)

(52) **U.S. Cl.** **349/65; 349/61**

10 Claims, 8 Drawing Sheets

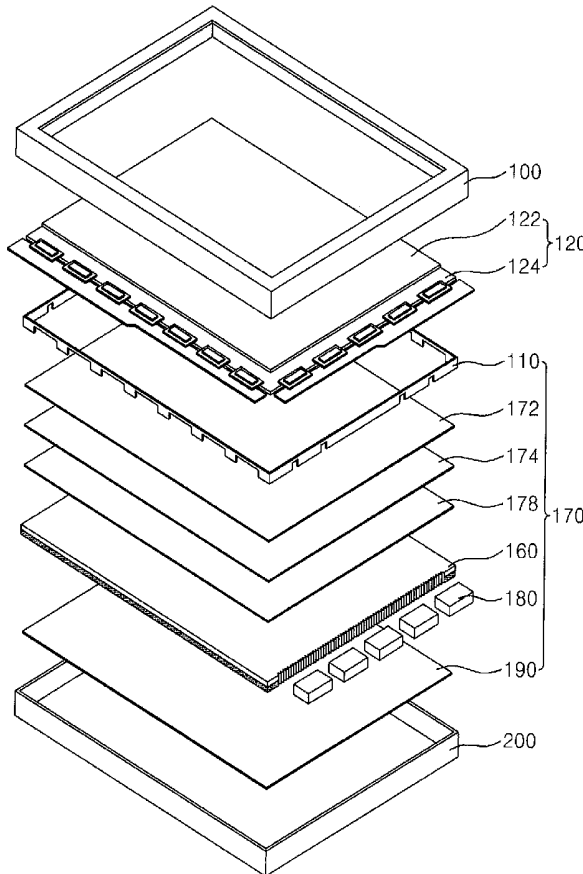

FIG. 1

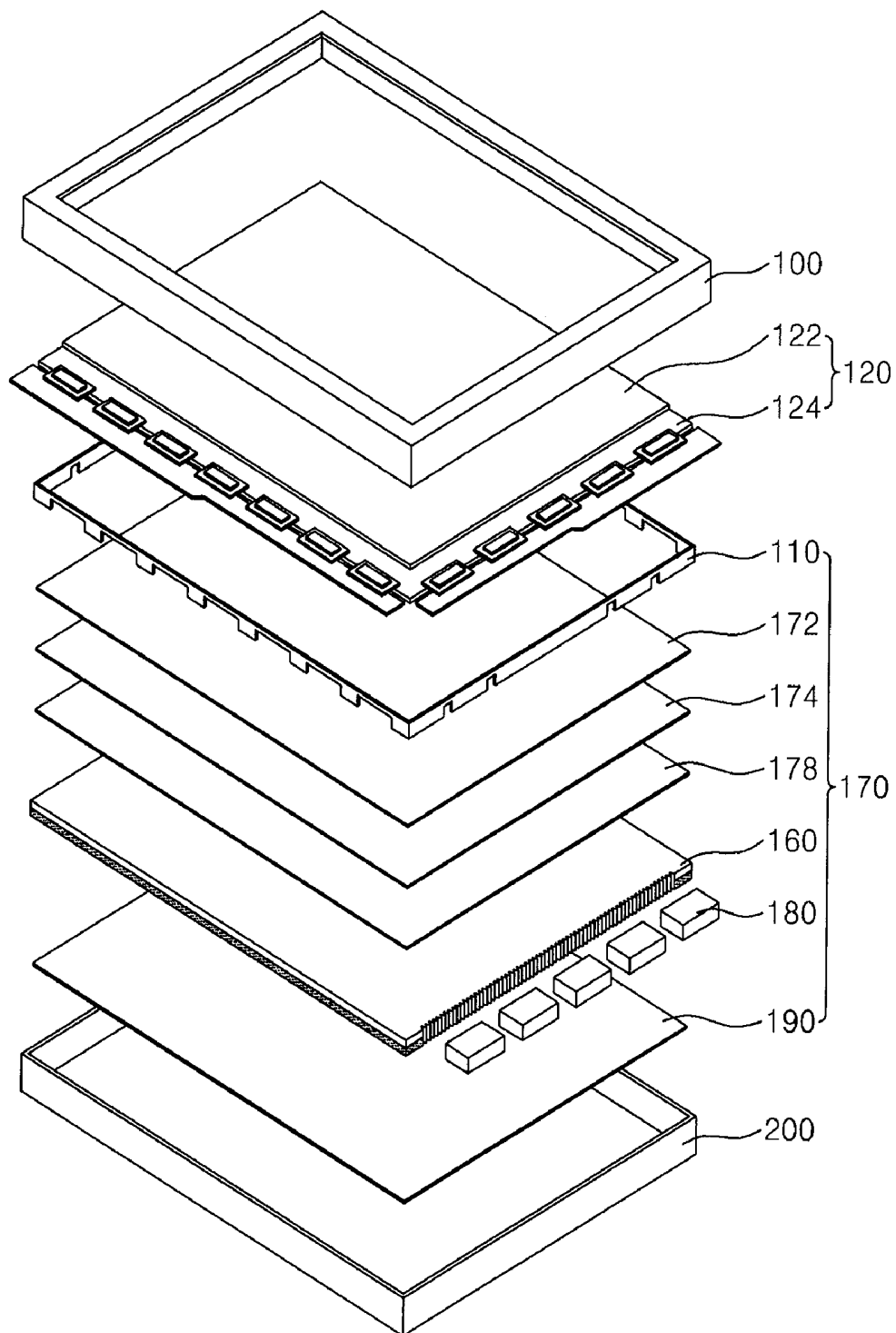

FIG. 2

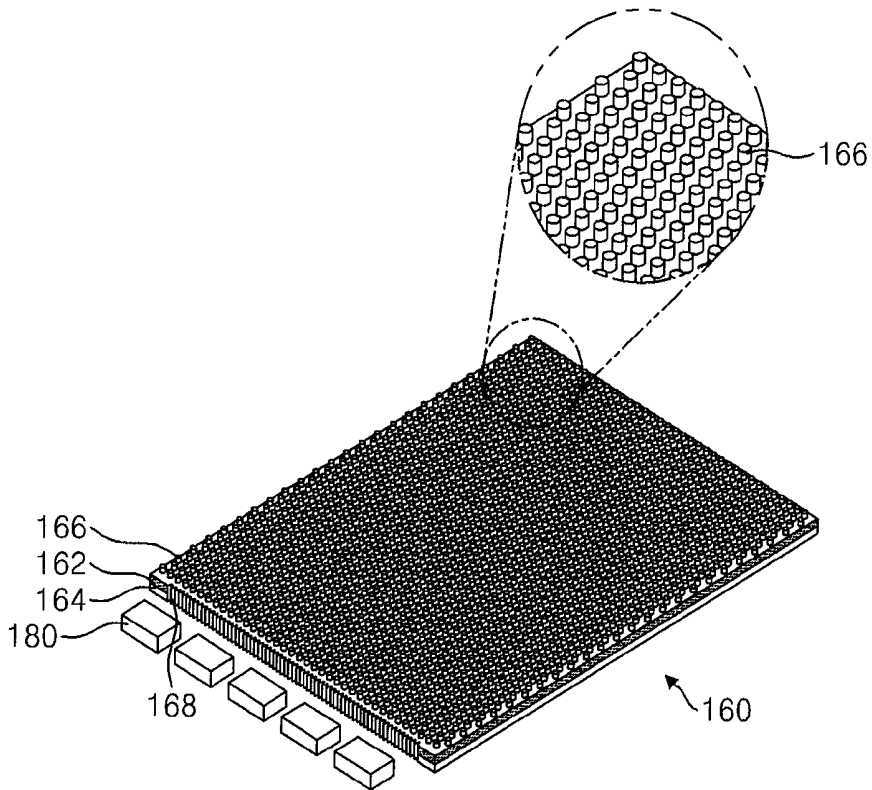

FIG. 3

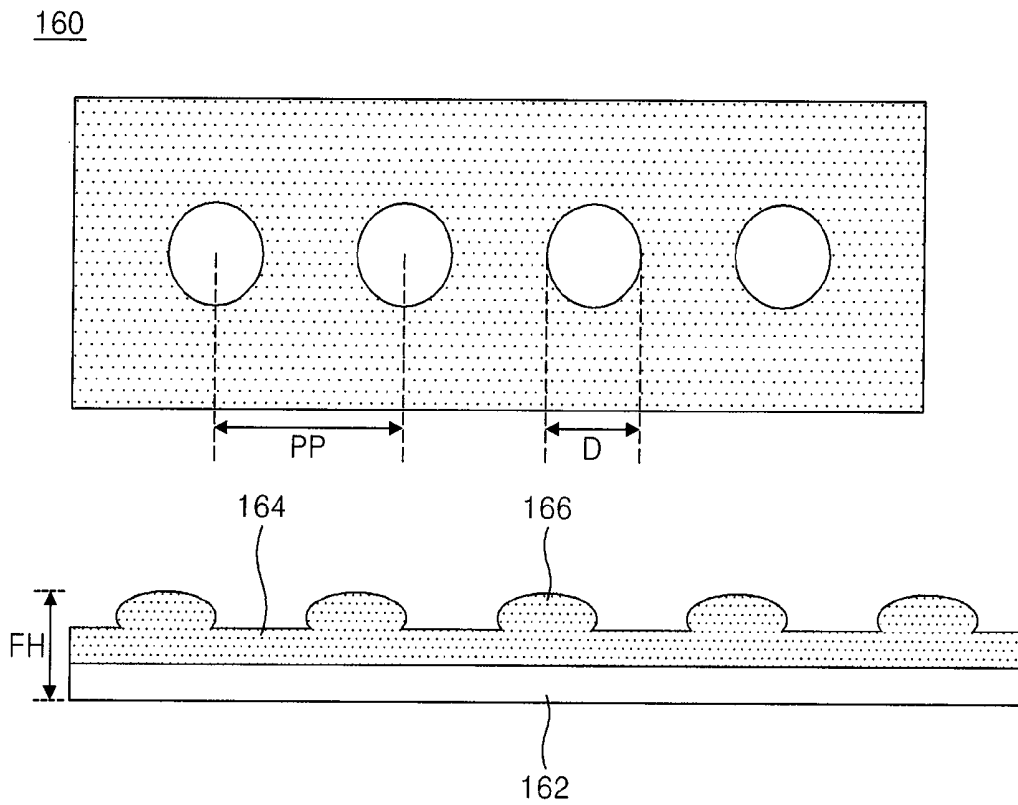

FIG. 4

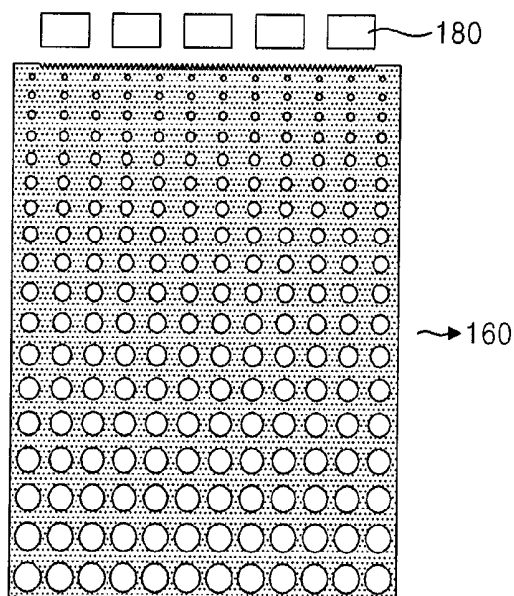

FIG. 5

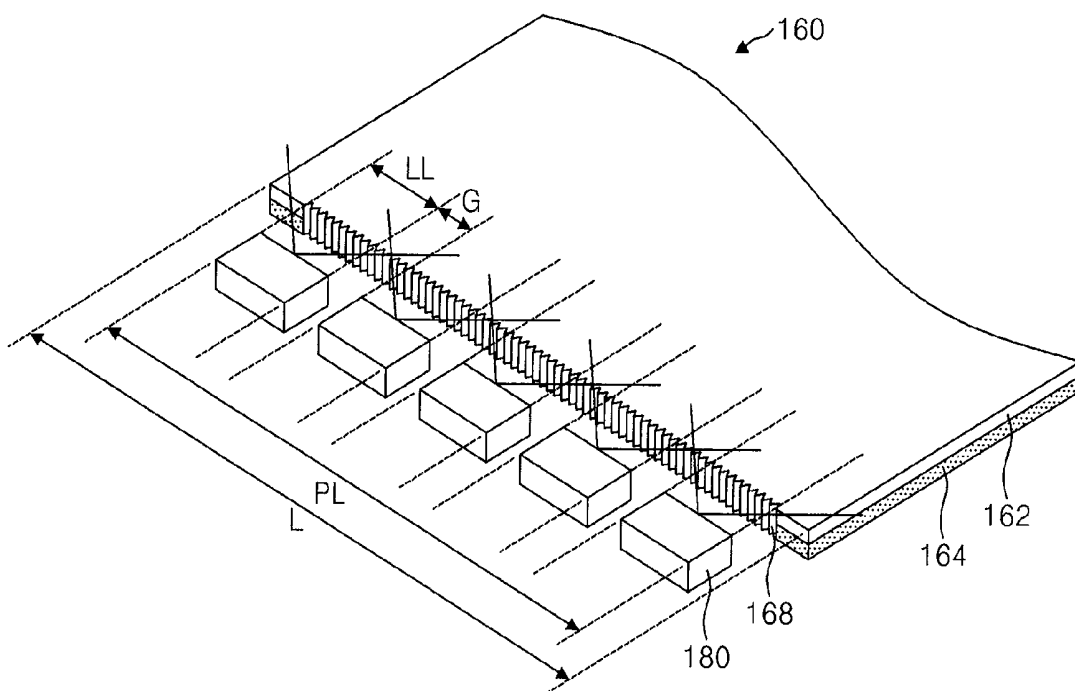

FIG. 6

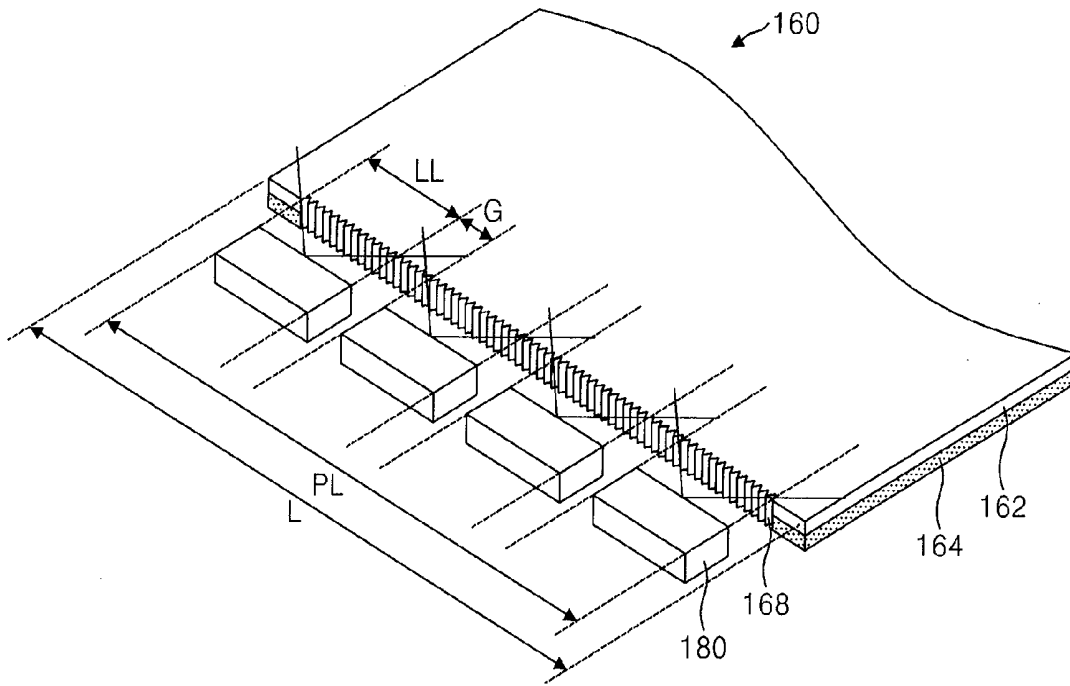

FIG. 7

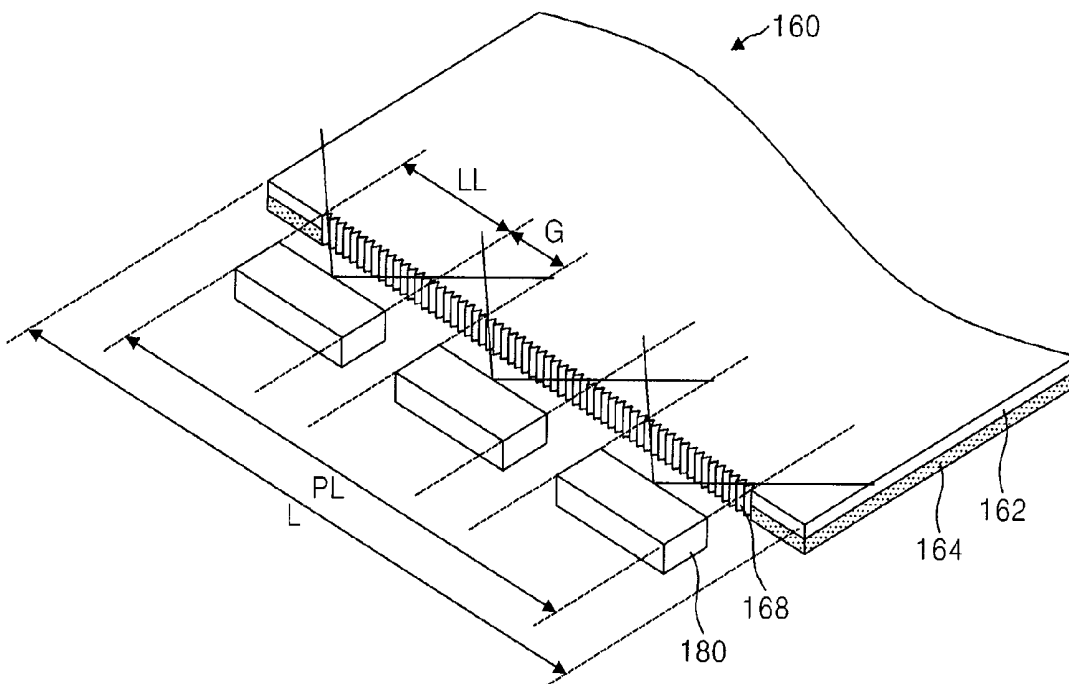

FIG. 8

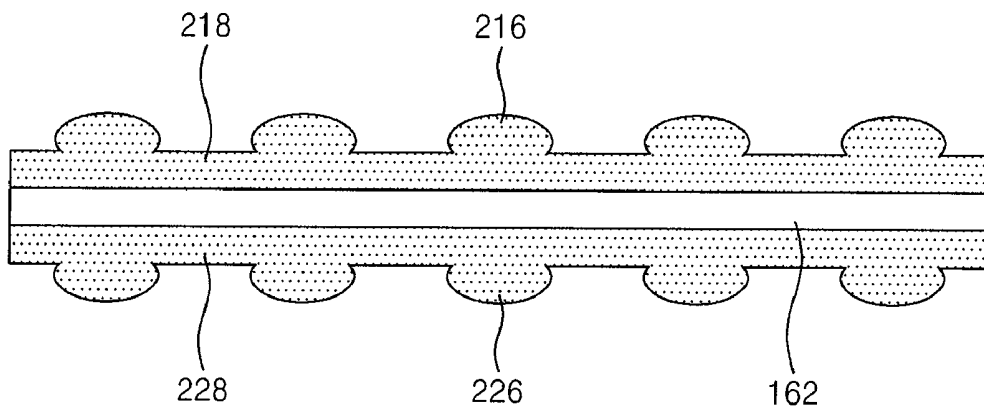

FIG. 9A

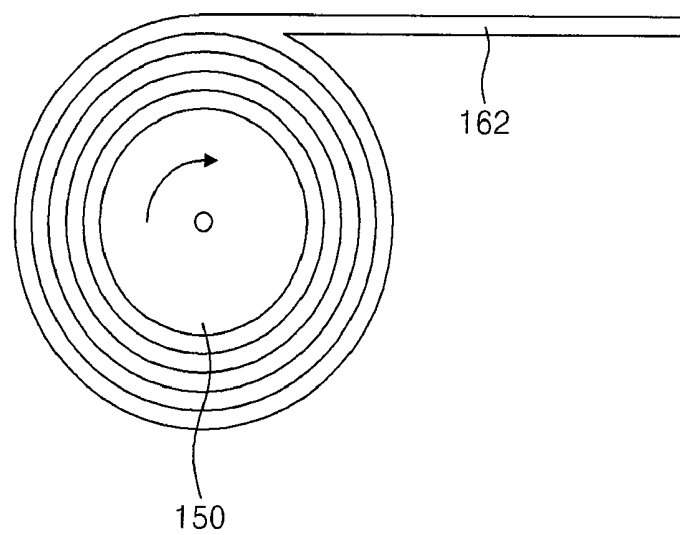

FIG. 9B

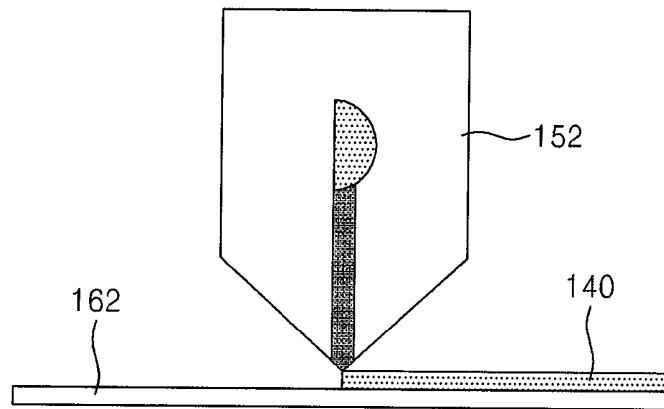

FIG. 9C

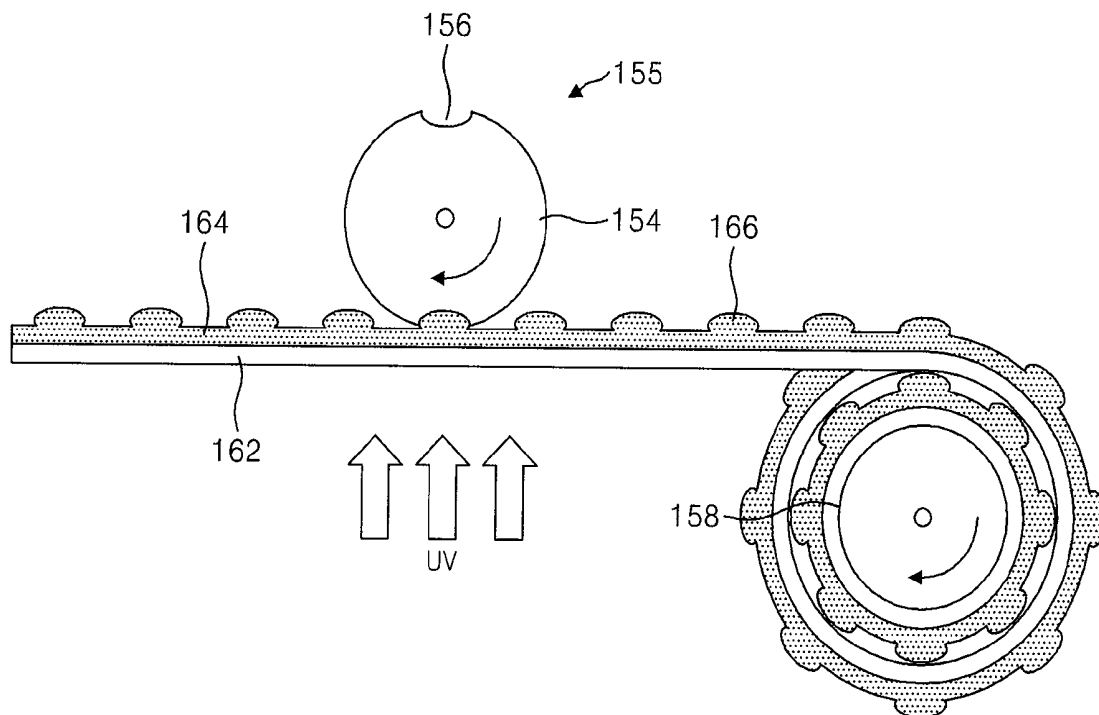

FIG. 10

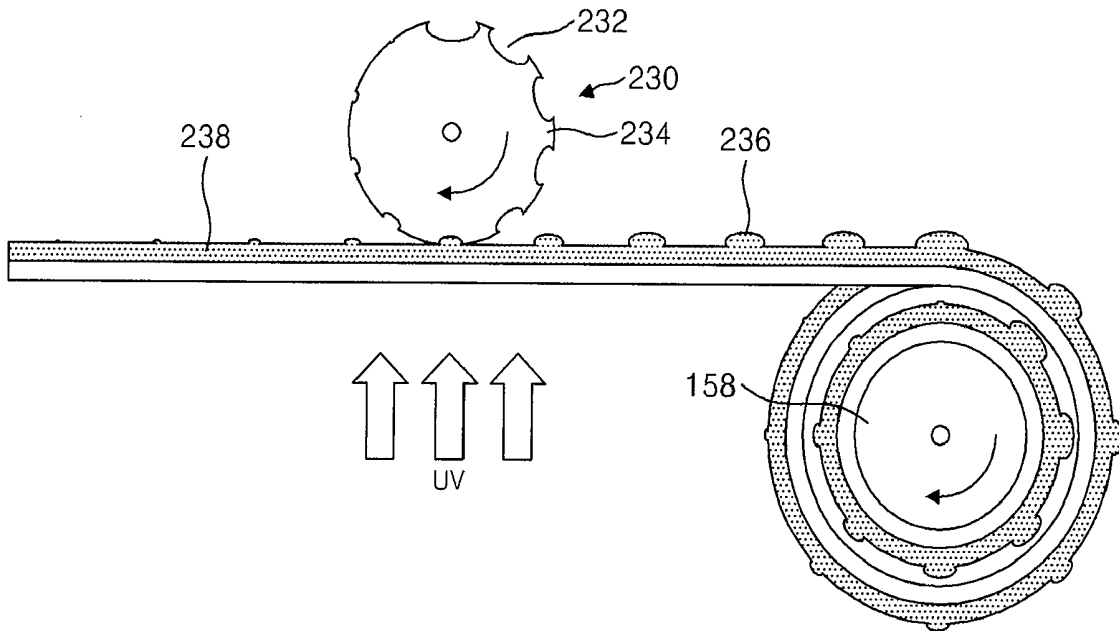

FIG. 11A

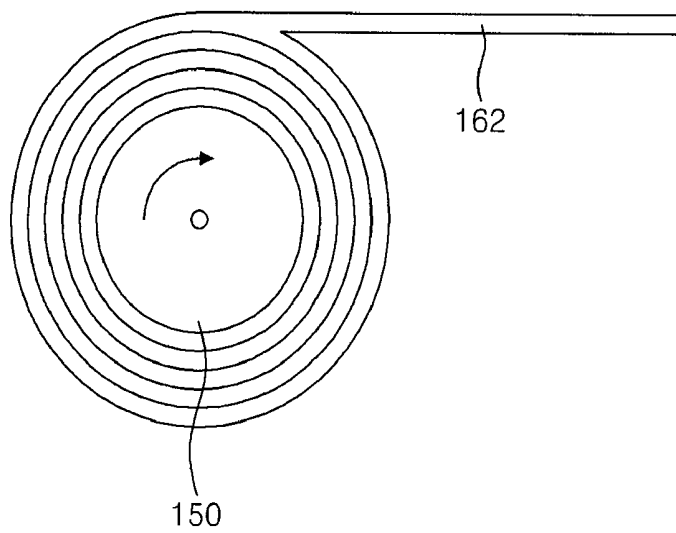

FIG. 11B

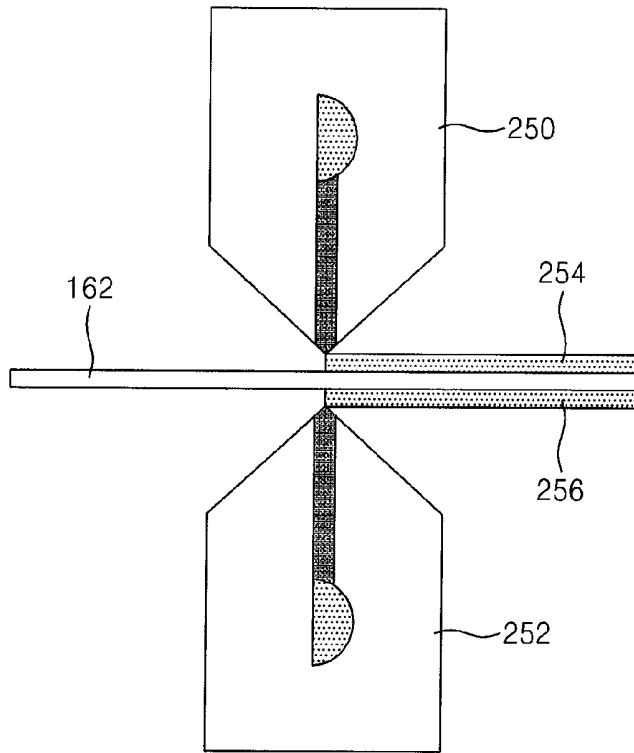
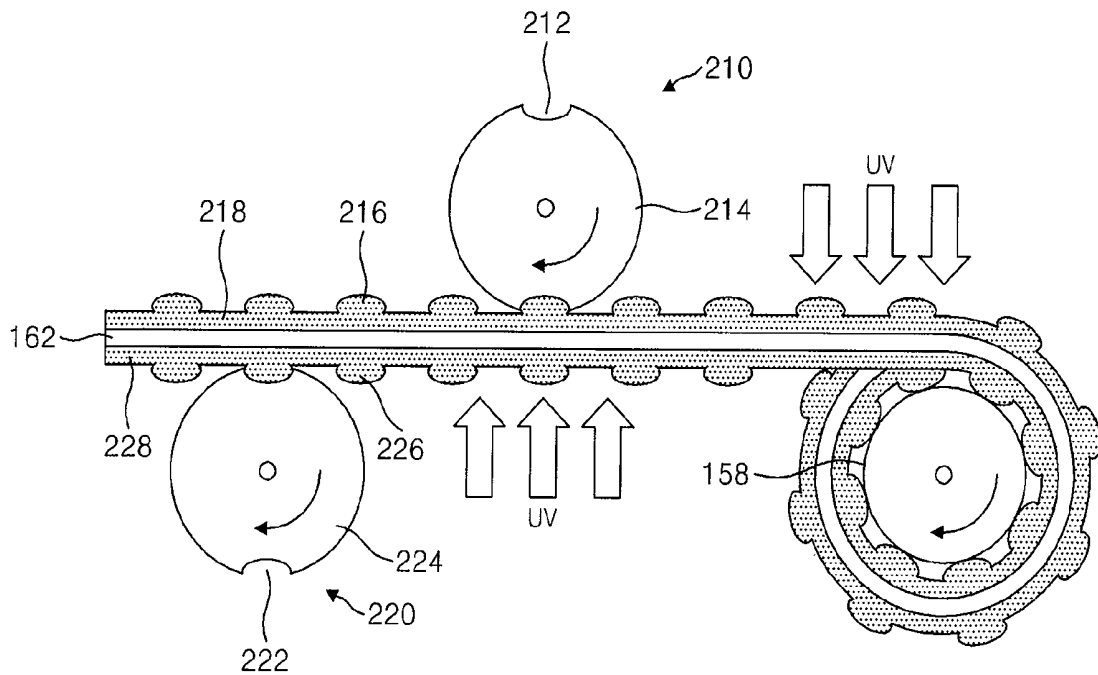

FIG. 11C



LIQUID CRYSTAL DISPLAY DEVICE HAVING IMPROVED LIGHT GUIDE PLATE

CROSS-REFERENCE TO RELATED APPLICATION(S)

This application claims priority from Korean Patent Application No. 2006-0121533 filed in the Korean Patent Office on Dec. 4, 2006, the entire content of which is incorporated by reference herein.

BACKGROUND OF THE INVENTION

1. Field of the Invention

The present invention relates to a liquid crystal display ("LCD") device and, in particular, to a backlight assembly having an improved light guide plate and a manufacturing method therefore.

2. Description of the Related Art

An LCD device has a structure in which liquid crystal cells are arranged between two transparent substrates in the form of a matrix, and a backlight assembly for providing light to the LCD panel.

A conventional backlight assembly includes a plurality of lamps, lamp housing for protecting the lamps, a light guide plate for guiding the light emitted from the lamps to the LCD panel, a reflection sheet arranged behind the light guide plate, and a plurality of optical sheets stacked on the light guide plate. Typically, the thickness of the backlight assembly occupies 50% to 95% of the total thickness of the LCD device of which the thickness of the light guide plate occupies 50% to 80%. Accordingly, the larger the thickness of the light guide plate becomes, the more difficult it is to manufacture a thin LCD device. Moreover, the dot and prism patterns for improving light efficiency formed on the rear surface of the light guide plate use a printing process that requires considerable manufacturing time, which results in a decrease in productivity.

SUMMARY OF THE INVENTION

The present invention, according to one aspect, provides a thin and lightweight LCD device having an easily manufactured light guide plate.

In accordance with an aspect of the present invention, a backlight assembly for a liquid crystal display device having a liquid crystal panel includes a light source for providing light to the liquid crystal display panel, a light guide plate including at least two thin layers for guiding the light from the light source to the liquid crystal display panel; and a plurality of optical sheets sequentially stacked over the rear surface of the liquid crystal panel, wherein the light guide plate includes a first thin layer formed of an optical film and a second thin layer stacked on the first thin layer and having a dot pattern.

The light guide plate includes a prism pattern formed in a shape selected a group consisting of a V shape, a saw tooth shape and a triangular shape on a light incident portion of the light guide plate facing the light source.

The prism pattern is formed with a length determined by the following formula:

$$PL > \frac{N-1}{N} * 100\%$$

wherein PL denotes the length of the prism pattern and N is the number of LED lamps.

The optical film comprises polycarbonate (PC), polyethylene terephthalate (PET), or the like.

The light guide plate is formed with a thickness in the range of about 20 μm to about 600 μm .

The dot pattern includes a plurality of dots whose diameters become larger as being distanced away from the light source. The dot pattern may include a plurality of dots whose diameters are in the range of about 20 μm to about 200 μm and where adjacent dots of the dot pattern are separated from each other by a distance in the range of about 100 μm to about 120 μm .

In accordance with another aspect of the present invention, there is provided a liquid crystal display including a liquid crystal display panel; a number of light sources providing light to the liquid crystal display panel; a light guide plate including at least two thin layers for guiding the light emitted by the light source to the liquid crystal display panel; a plurality of optical sheets sequentially stacked over the rear surface of the liquid crystal display panel; a bottom chassis accommodating the liquid crystal display panel, the light sources, the light guide plate, and the optical sheets; and a top chassis surrounding edges of the liquid crystal display panel and covering the lateral sides of the bottom chassis, wherein light guide plate includes a first thin layer formed of an optical film and a second thin layer stacked on the first thin layer and layer having a dot pattern.

The light guide plate includes a prism pattern having a shape selected from a group consisting of a V shape, a saw tooth shape, and a triangular shape formed on a light incident surface of the light guide plate facing the light sources.

The prism pattern may be formed having a length determined by the following formula:

$$PL > \frac{N-1}{N} * 100\%$$

where PL denotes the length of the prism pattern and N is the number of LED lamps.

The prism pattern is formed facing the LED lamps and facing the area between the spaced apart LED lamps.

The optical film comprises polycarbonate (PC), polyethylene terephthalate (PET), or the like.

The second thin layer is formed of an ultraviolet-curing resin.

The light guide plate is formed with a thickness in the range of about 20 μm to about 600 μm .

The dot pattern includes a plurality of dots whose diameters become larger as being distanced away from the light sources. Moreover, the dot pattern includes a plurality of dots whose diameters are in the range of about 20 μm to about 200 μm and that are spaced apart from each other at a distance in the range of about 100 μm to about 120 μm .

In accordance with a further aspect of the present invention, a method of manufacturing a light guide plate for a liquid crystal display comprises: preparing a first thin layer wound around a first roller base; coating an ultraviolet-curing resin on the first thin layer; pressurizing or embossing the top of the ultraviolet-curing resin with a rotating mold having a groove and a protrusion; forming a second thin layer having a dot pattern in the area corresponding to the groove as the rotating mold comes in contact with the top of the ultraviolet-curing resin; curing the second thin layer having the dot pattern; and

winding the light guide plate formed with the first and second thin layers around a second roller.

Preferably, the optical film comprises polycarbonate (PC), polyethylene terephthalate (PET), or the like.

Moreover, the dot pattern includes a plurality of dots whose diameters are in the range of about 20 μm to about 200 μm .

The dots are formed with a distance in the range of about 100 μm to about 120 μm .

Furthermore, the light guide plate has a thickness in the range of about 20 μm to about 600 μm .

In addition, the dot pattern includes a plurality of dots whose diameters become larger as being distanced away from the light sources.

BRIEF DESCRIPTION OF THE DRAWINGS

The above and other objects, features and advantages of the present invention will be more apparent from the following detailed description in conjunction with the accompanying drawings, in which:

FIG. 1 is an exploded perspective view showing an LCD device according to an exemplary embodiment of the present invention;

FIG. 2 is a perspective view showing a light guide plate according to an exemplary embodiment of the present invention;

FIG. 3 is a top plan view and a cross-sectional view enlarging a portion of the light guide plate shown in FIG. 2;

FIG. 4 is a top plan view showing a second thin layer of a light guide plate according to another exemplary embodiment of the present invention;

FIG. 5 is a partial perspective view of the light guide plate and LED lamps of FIG. 2 for illustrating a light incident portion of the light guide plate according to the present invention;

FIGS. 6 and 7 are partial perspective views illustrating light incident portions of light guide plates according to other exemplary embodiments of the present invention;

FIG. 8 is a cross sectional view showing a light guide plate according to another embodiment of the present invention;

FIGS. 9A to 9C are cross sectional views illustrating a process for manufacturing the light guide plate shown in FIG. 2;

FIG. 10 is a cross sectional view illustrating a process for forming the second thin layer shown in FIG. 4; and

FIGS. 11A to 11C are cross sectional views illustrating a process for manufacturing the light guide plate shown in FIG. 8.

DETAILED DESCRIPTION OF EXEMPLARY EMBODIMENTS

FIG. 1 is an exploded perspective view showing an LCD device according to an exemplary embodiment of the present invention, and FIG. 2 is a perspective view showing a light guide plate according to an exemplary embodiment of the present invention.

Referring to FIG. 1, the LCD device includes an LCD panel 120 for displaying a picture in accordance with applied image signals, a backlight assembly 170 for providing light to the LCD panel 120, a mold frame 110 for accommodating the LCD panel 120 and the backlight assembly 170, a top chassis 100, and a bottom chassis 200.

The LCD panel 120 includes a thin film transistor ("TFT") substrate 124 and a color filter substrate 122 facing the TFT substrate 124. Liquid crystal is injected between the TFT substrate 124 and the color filter substrate 122 and thereby the

LCD panel 120 displays a picture by adjusting the light transmissivity of the liquid crystal using TFTs arranged in the form of a matrix as switching elements. The color filter substrate 122 includes a color filter including red, green, and blue color filter segments corresponding to respective sub-pixel regions such that a picture can be displayed by the light passing through the color filter.

The top chassis 100 is configured to cover edges of the top surface of the LCD panel 120 and its up/down/left/right sides are to cover the lateral sides of the mold frame 110 and the bottom chassis 200.

The mold frame 110 accommodates the LCD panel 120 and the backlight assembly 170 to prevent the movements and to absorb an impact applied from the outside to the LCD panel 120 and the backlight assembly 170. Preferably, the mold frame 110 is made of a synthetic resin or plastic material for insulating the driving circuit.

The backlight assembly 170 including light emitting diode ("LED") lamps 180, a reflection sheet 190, a light guide plate 160, a diffusing sheet 178, a prism sheet 174, and a protecting sheet 172 provides light to the LCD panel 120.

The LED lamps 180 arranged at regular intervals provide light to the light guide plate 160. Such an LED lamp 180 is a PN junction semiconductor diode that emits photons when forward biased. The light-emission occurs when minority carriers recombine with carriers of the opposite type in the diode's band gap. The LED lamp 180 may be a typical LED, a high brightness LED, or the like. The typical LED emits light of uniform brightness without a voltage drop when current is applied, whereas, the high brightness LED emits light of high brightness and causes a voltage drop while emitting the light.

Two to three diffusing sheets 178 and prism sheets 174 may be appropriately combined with each other to diffuse or collect the light emitted from the light guide plate 160 and to improve brightness and viewing angle. The protection sheet 172 is provided on the diffusing sheet 178 or the prism sheet 174 to protect the sheets against scratches and to prevent the sheets from being moved while transporting the backlight assembly 170.

The reflection sheet 190 reflects the light emitted to the bottom of the light guide plate 160 back to the light guide plate 160. For this purpose, the reflection sheet 190 is formed by coating a preform with a highly reflective material. The preform used may be aluminum (Al), polyethylene terephthalate (PET), etc. and the reflective material may be silver (Ag), titanium (Ti), etc.

The light guide plate 160 formed with at least two thin layers 162 and 164 diffuses the light emitted from the LED lamps 180 onto the whole surface of the light guide plate 160, uniformly. The thin layers 162 and 164 will be referred to as first and second thin layers, for the sake of convenience, but more layers may be used.

Referring to FIG. 3, the first thin layer 162 is formed of an optical film, and the second thin layer 164 is stacked on the rear surface of the first thin film 162. The optical film comprises polycarbonate (PC), polyethylene terephthalate (PET), or the like. As the first thin layer 162 is formed with the optical film, the thickness of the light guide plate 160 can be reduced and it is thus possible to manufacture a thin light guide plate 160. As shown in the figure, it is possible to form the light guide plate 160 including the two thin layers 162 and 164 very thin, with a thickness FH in the range of about 20 μm to about 600 μm .

The second thin layer 164 includes a dot pattern having a plurality of dots in a polygonal, semi-oval, or semicircular shape so as to change the angle of light incident upon the LCD

panel **120**, and diffuse it, thus improving the brightness and viewing angle. The second thin layer **164** is made of an ultraviolet-curing resin using an imprinting process. Advantageously, the distance PP between the centers of adjacent circles of the dot pattern is about 100 to about 120 μm and the circles of the dot pattern **166** may each have a diameter D in the range of about 20 μm to about 200 μm .

FIG. 4 is a top plan view showing a second thin layer **164** of a light guide plate **160** according to another embodiment of the present invention. As shown in the figure, the dot pattern may be formed such that the diameters of the circles on the second thin layer **164** become gradually larger from the area adjacent to the LED lamps **180** toward the opposite side thereby more uniformly diffusing the light over the area where no LED lamp present.

FIG. 5 is a partial perspective view of the light guide plate and LED lamps of FIG. 2 for illustrating a light incident portion of the light guide plate according to the present invention. As shown in the figure, the light incident portion L of the light guide plate **160** has a prism pattern **168** formed in a V shape, saw tooth, or triangular shape, so as to efficiently diffuse the light emitted from the LED lamps **180**. The LED lamps **180** are arranged to be spaced apart from each other at regular intervals and to face the light incident portion L of the light guide plate **160**. Moreover, the prism pattern **168** is formed at the area LL corresponding to the LED lamps **180** and as well as at the area corresponding to the gap G between the LED lamps **180** which may be spaced apart from each other. In other words, the length PL of the prism pattern **168** formed on the light incident portion L of the light guide plate **160** is determined by the following formula:

$$PL > \frac{N-1}{N} * 100\%$$

wherein N denotes the number of LED lamps.

For example, if the first to fifth LED lamps **180** are arranged facing the light incident portion L of the light guide plate **160**, the length PL of the prism pattern **168** should be over 80% of the total length of the light incident portion L in accordance with formula 1. That is, the prism pattern **168** is formed from the area corresponding to the first LED lamp **180** to the area corresponding to the fifth LED lamp **180**.

FIGS. 6 and 7 are partial perspective views illustrating light incident portions of light guide plates according to other embodiments of the present invention. As shown in FIG. 6, if the first to fourth LED lamps **180** are formed, the length PL of the prism pattern **168** should be over 75% of the total length of the light inlet part L in accordance with formula 1. Moreover, as shown in FIG. 7, if the first to third LED lamps **180** are formed, the length PL of the prism pattern **168** should be over 66% of the total length of the light inlet part L in accordance with formula 1. Accordingly, the formation process of the prism pattern **168** in accordance with the present invention can be simplified compared with the conventional prism pattern that should be formed at every area corresponding to the LED lamps.

FIG. 8 is a cross sectional view showing a light guide plate according to another embodiment of the present invention.

Referring to FIG. 8, the light guide plate **160** includes first to third thin layers **162**, **218** and **228**. The second thin layer **218** is formed on the front surface of the first thin layer **162**, and the third thin layer **228** is arranged on the rear surface of the first thin layer **162**. The first thin layer **162** is formed of an optical film. The second and third thin layers **218** and **228**

include a dot pattern having a plurality of dots in a polygonal, semi-oval, or semicircular shape so as to change the light incident angle toward the LCD panel **120** and diffuse the light to improve brightness and viewing angle. Accordingly, detailed descriptions of the first to third thin layers **162**, **218** and **228** having the same structure as that of the first embodiment of the present invention will be omitted.

FIGS. 9A to 9C are cross sectional views illustrating a process for manufacturing the light guide plate according to the present invention.

As shown in FIG. 9A, a first thin layer **162** is wound around a first base roller **150**. The first thin layer **162** is formed of an optical film comprising polycarbonate (PC), polyethylene terephthalate (PET), or the like. The first thin layer **162** is transferred to a resin coating apparatus. As shown in FIG. 9b, the resin coating apparatus **152** coats the surface of the first thin layer **162** with an ultraviolet-curing resin **140**.

Subsequently, a rotating imprint mold **155** having a groove **156** and a protrusion **154** is arranged on the ultraviolet-curing resin **140** as shown in FIG. 9C. The rotating imprint mold **155** rotates in a predetermined direction to bring the surface of the protrusion **154** into contact with the ultraviolet-curing resin **140**, thus embossing the ultraviolet-curing resin **140**.

Accordingly, as a portion of the ultraviolet-curing resin **140** is moved into the groove **156** of the rotating imprint mold **155**, a second thin layer **164** to which the dot pattern **166** is transferred by the groove **156** of the rotating imprint mold **155** is formed. The dots of the dot pattern **166** may be formed to have diameters in the range of 20 μm to 200 μm and with the distance between adjacent dots in the range of about 100 μm to about 120 μm . The second thin layer **164** formed on the first thin layer **162** is then cured by ultraviolet radiation. Next, the first and second thin layers **162** and **164** are wound sequentially around a second base roller **158**.

FIG. 10 is a cross sectional view illustrating a process for forming a second thin layer according to another exemplary embodiment of the present invention. As shown in the figure, a rotating imprint mold **230** including a plurality of grooves **232** having different sizes is used to form the dot pattern **236** having a plurality of dots with a variety of diameters on the second thin layer **238**. That is, the dots of the dot pattern **236** formed on the second thin layer **238** have diameters that become larger, gradually.

The dot pattern on the second thin layer **238** may be varied by modifying the imprint mold **230** to ensure an efficient manufacturing process.

FIGS. 11A to 11C are cross sectional views illustrating a process for manufacturing a light guide plate according to a further exemplary embodiment of the present invention.

First, as shown in FIG. 11A, a first thin layer **162** is wound around a first base roller **150**. The first thin layer is formed of an optical film comprising polycarbonate, polyethylene terephthalate (PET), or the like. The first thin layer **162** is transferred to first and second resin coating apparatuses **250** and **252** as shown in FIG. 11B. The first and second resin coating apparatuses **250** and **252** coat the front and rear surfaces of the first thin layer **162** with first and second ultraviolet-curing resins **254** and **256**.

Subsequently, a first rotating imprint mold **210** having a groove **212** and a protrusion **214** is arranged on the top of the first ultraviolet-curing resin **254**, and a second rotating imprint mold **220** having a groove **222** and a protrusion **224** is arranged on the top of the second ultraviolet-curing resin **256** as shown in FIG. 11C. Such first and second rotating imprint molds **210** and **220** rotate in a predetermined direction to bring the surfaces of the protrusions **214** and **224** of the first and second rotating imprint molds **210** and **220** into contact

with the first and second ultraviolet-curing resins **254** and **256**, thus embossing the first and second ultraviolet-curing resin **254** and **256**. Accordingly, as portions of the first and second ultraviolet-curing resin **254** and **256** are moved into the grooves **212** and **222** of the rotating imprint molds **210** and **220**, the second and third thin layer **218** and **228** are formed with dot patterns **216** and **226** transferred by the grooves **212** and **222**. Here, it is possible to form the dot pattern **166** with a diameter in the range of 20 μm to 200 μm and with the distance between the dots adjacent to each other in the range of about 100 μm to about 120 μm. The second and third thin layer **218** and **228** formed on the first thin layer **162** are then cured by ultraviolet radiation. Next, the second and third thin layers **218** and **228** formed on the front and rear surfaces of the first thin layer **162** are wound around the second base roller **158**.

As described above in detail, the light guide plate is formed having a first thin layer formed of an optical film and a second thin layer having a dot pattern formed on the rear surface of the first thin layer using an imprint mold. With the use of the optical film as the first thin layer, it is possible to reduce the total thickness of the light guide plate, and thereby to manufacture the LCD device in a thin and lightweight design. Moreover, the manufacturing method of the light guide plate in accordance with the present invention can simplify the manufacturing process, reduce the manufacturing time and thereby improve the productivity by conveying the light guide plate using a roll-to-roll process and by forming the dot pattern on the second thin layer using a rotating imprint mold.

Furthermore, the present invention can improve the light efficiency of the LCD device by forming the prism pattern in a V shape all over the light incident portion of the light guide plate, not limited to the areas facing the light sources.

Although exemplary embodiments of the present invention have been described in detail hereinabove, it should be clearly understood that many variations and/or modifications of the basic inventive concepts herein taught which may appear to those skilled in the present art will still fall within the spirit and scope of the present invention, as defined in the appended claims.

What is claimed is:

1. A backlight assembly for a liquid crystal display having a liquid crystal panel, comprising:
 - a light source for providing light to the liquid crystal display panel;
 - a light guide plate including at least two thin layers for guiding the light from the light source to the liquid crystal display panel; and
 - a plurality of optical sheets sequentially stacked over the rear surface of the liquid crystal panel,
 wherein the light guide plate includes a first thin layer formed of an optical film and a second thin layer stacked on the first thin layer and having a dot pattern, the dot pattern includes a plurality of dots whose diameters become larger as being distanced away from the light source, and
 - the light guide includes a prism pattern having a shape selected from a group consisting of a V shape, a saw tooth shape, and a triangular shape on a light incident portion of the light guide plate facing the light source.
2. The backlight assembly of claim 1, wherein the prism pattern is formed with a length determined by the following formula, and the prism pattern is formed at the area facing the LED lamps and at the area facing the gap between the spaced-apart LED lamps:

$$PL > \frac{N-1}{N} * 100\%,$$

wherein PL denotes the length of the prism pattern and N is the number of LED lamps.

3. The backlight assembly of claim 2, wherein the optical film comprises polycarbonate (PC), polyethylene terephthalate (PET).

4. The backlight assembly of claim 2, wherein the light guide plate is formed with a thickness in the range of about 20 μm to about 600 μm.

5. The backlight assembly of claim 1, wherein the dot pattern includes a plurality of dots whose diameters are in the range of about 20 μm to about 200 μm, wherein the distance between adjacent dots of the dot pattern is in the range of about 100 μm to about 120 μm.

6. A liquid crystal display comprising:

- a liquid crystal display panel;
- one or more light sources providing light to the liquid crystal display panel;
- a light guide plate including at least two thin layers and guiding the light emitted by the light source to the liquid crystal display panel;
- a plurality of optical sheets sequentially stacked on the rear surface of the liquid crystal display panel;
- a bottom chassis accommodating the liquid crystal display panel, the light sources, the light guide plate, and the optical sheets; and
- a top chassis surrounding edges of the liquid crystal display panel and covering the lateral sides of the bottom chassis,

wherein the light guide plate includes a first thin layer formed of an optical film and a second thin layer stacked on the first thin layer and having a dot pattern, the dot pattern includes a plurality of dots whose diameters become larger as being distanced away from the light source, and

the light guide includes a prism pattern having a shape selected from a group consisting of V shape, a saw tooth shape, and a triangular shape on a light incident portion of the light guide plate facing the light sources.

7. The liquid crystal display of claim 6, wherein the prism pattern is formed with a length determined by the following formula, and the prism pattern is formed in the area facing the LED lamps and in the area facing the gap between the LED lamps spaced apart from each other:

$$PL > \frac{N-1}{N} * 100\%,$$

wherein PL denotes the length of the prism pattern and N is the number of LED lamps.

8. The liquid crystal display of claim 6, wherein the second thin layer is formed of an ultraviolet-curing resin.

9. The liquid crystal display of claim 6, wherein the light guide plate has a thickness in the range of about 20 μm to about 600 μm.

10. The liquid crystal display of claim 6, wherein the dot pattern includes a plurality of dots whose diameters are in the range of about 20 μm to about 200 μm.

专利名称(译)	具有改进的导光板的液晶显示装置		
公开(公告)号	US7986383	公开(公告)日	2011-07-26
申请号	US11/931928	申请日	2007-10-31
[标]申请(专利权)人(译)	三星电子株式会社		
申请(专利权)人(译)	SAMSUNG ELECTRONICS CO. , LTD.		
当前申请(专利权)人(译)	三星DISPLAY CO. , LTD.		
[标]发明人	HAN BYUNG WOONG KIM DONG CHEOL KIM KYU SEOK SEO JEONG MIN CHU YOUNG BEE YI SANG MIN		
发明人	HAN, BYUNG-WOONG KIM, DONG-CHEOL KIM, KYU-SEOK SEO, JEONG-MIN CHU, YOUNG-BEE YI, SANG-MIN		
IPC分类号	G02F1/1335		
CPC分类号	B29D11/00663 G02B6/0035 G02B6/0016 G02B6/0043 G02B6/0065		
优先权	1020060121533 2006-12-04 KR		
其他公开文献	US20080129925A1		
外部链接	Espacenet USPTO		

摘要(译)

一种用于LCD装置的背光组件，其具有导光板，该导光板包括至少两个薄层和顺序堆叠在液晶面板的后表面上的多个光学片。

