



(19) **United States**

(12) **Patent Application Publication**
Kim et al.

(10) **Pub. No.: US 2009/0322989 A1**

(43) **Pub. Date: Dec. 31, 2009**

(54) **LIQUID CRYSTAL DISPLAY**

Publication Classification

(76) Inventors: **Hyojin Kim**, Chilgok-gun (KR);
Hyunki Kim, Dalseo-gu (KR)

(51) **Int. Cl.**
G02F 1/13357 (2006.01)

(52) **U.S. Cl.** **349/65**

Correspondence Address:
MCKENNA LONG & ALDRIDGE LLP
1900 K STREET, NW
WASHINGTON, DC 20006 (US)

(57) **ABSTRACT**

The liquid crystal display includes: a liquid crystal panel; a backlight unit that includes a light guide plate that is positioned at a lower part of the liquid crystal panel and that guides light emitted from a light source in a direction of the liquid crystal panel, and a plurality of optical sheets that provide light emitted from the light guide plate to the liquid crystal panel; and a plurality of step parts that are formed from a base surface to an upper surface in order to receive the liquid crystal panel and the backlight unit, wherein a step part facing the liquid crystal panel among the plurality of step parts includes a main support having an area patterned to be apart from the liquid crystal panel.

(21) Appl. No.: **12/318,518**

(22) Filed: **Dec. 30, 2008**

(30) **Foreign Application Priority Data**

Jun. 30, 2008 (KR) 10-2008-0062853

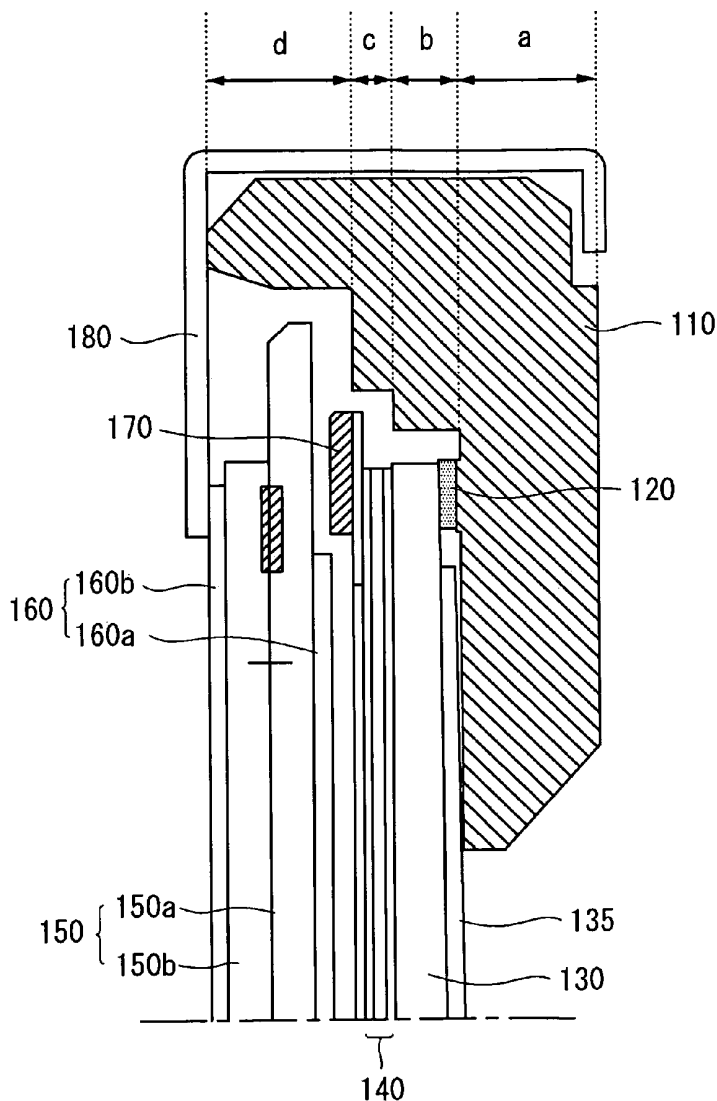

Fig. 1

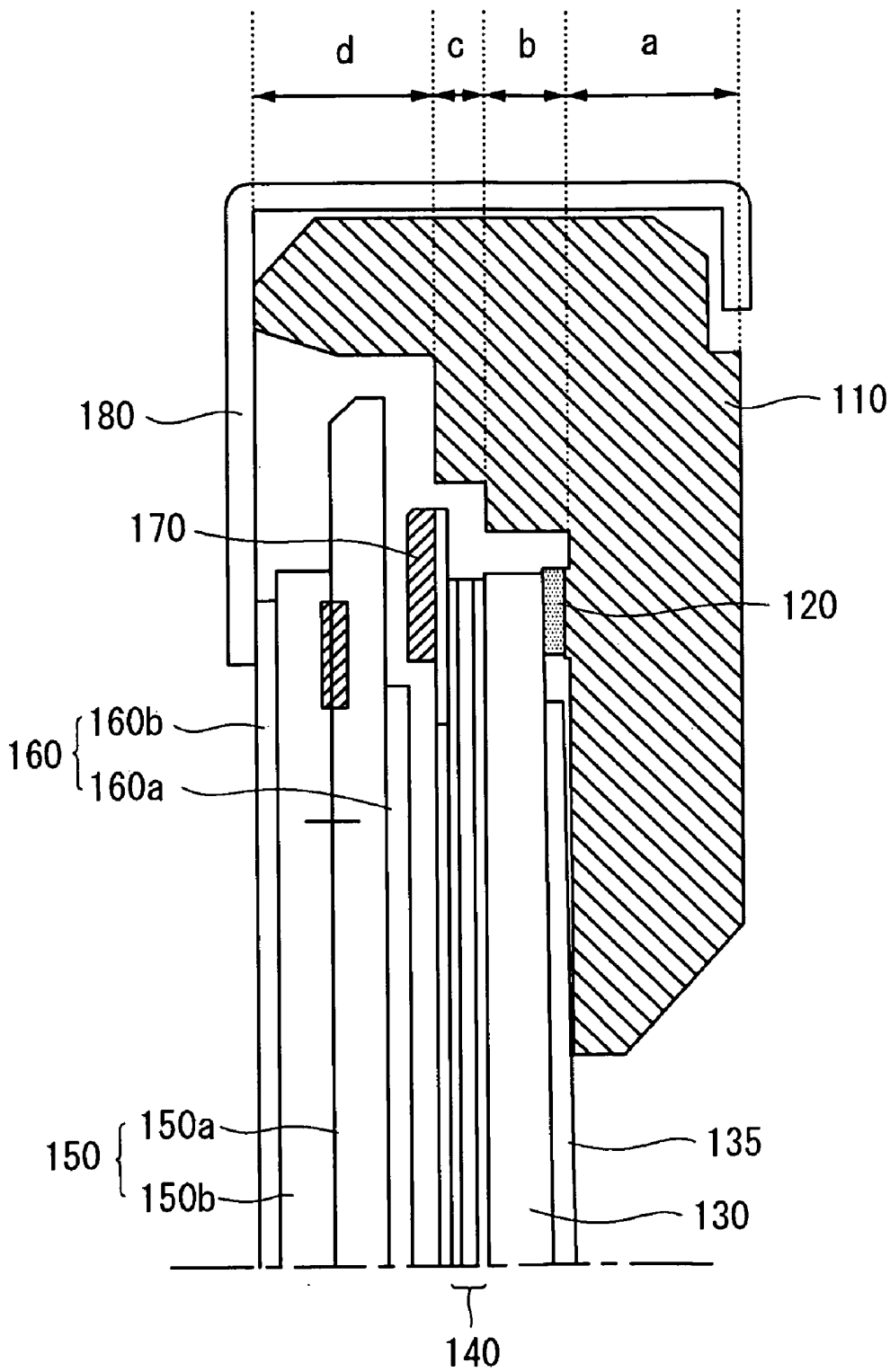

Fig. 2

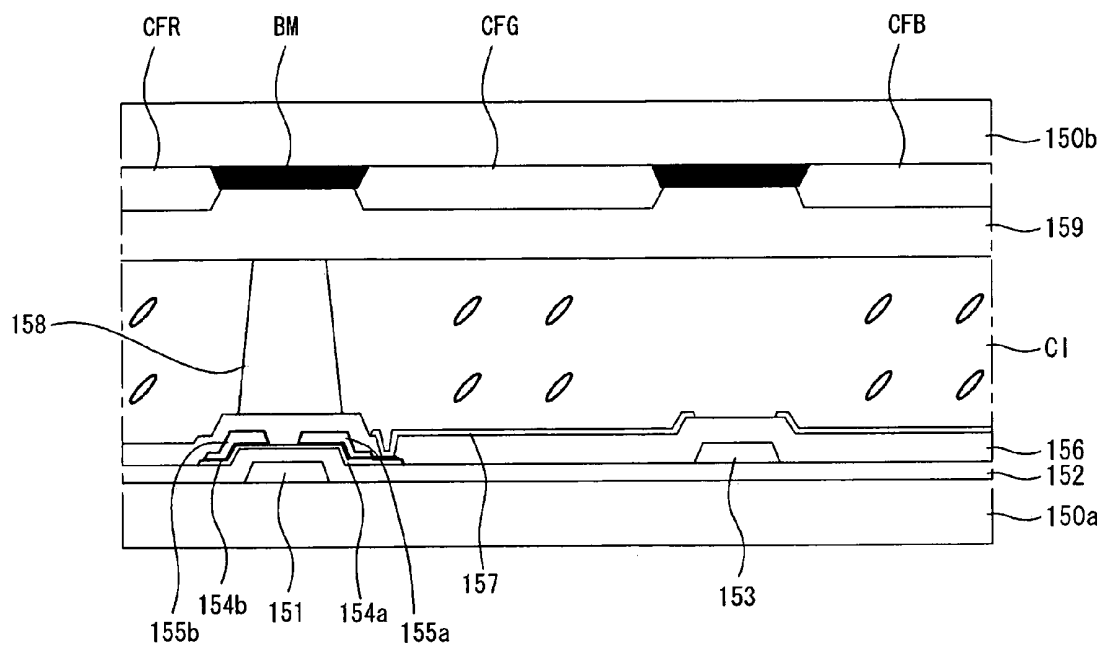

Fig. 3

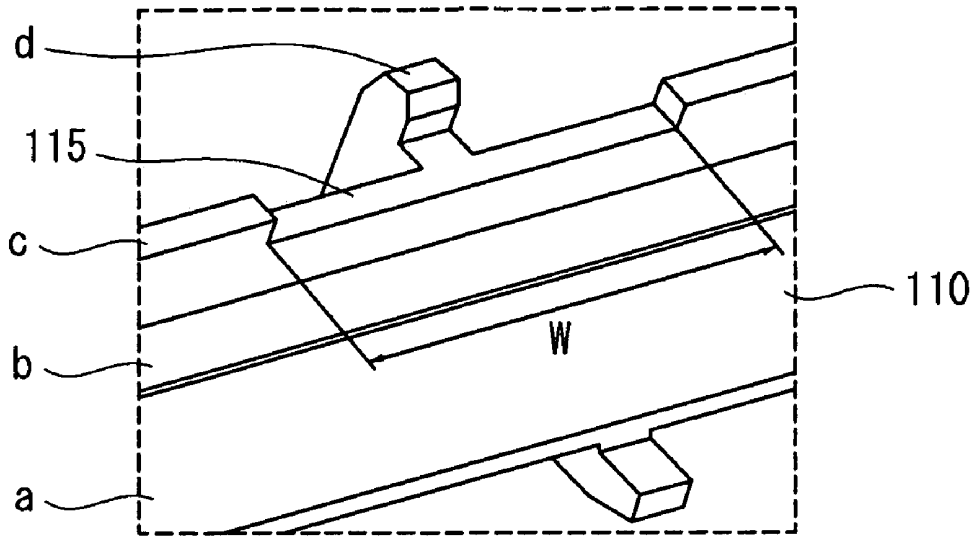

Fig. 4

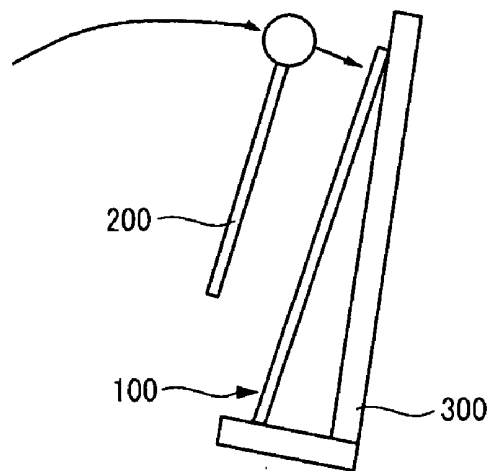

Fig. 5

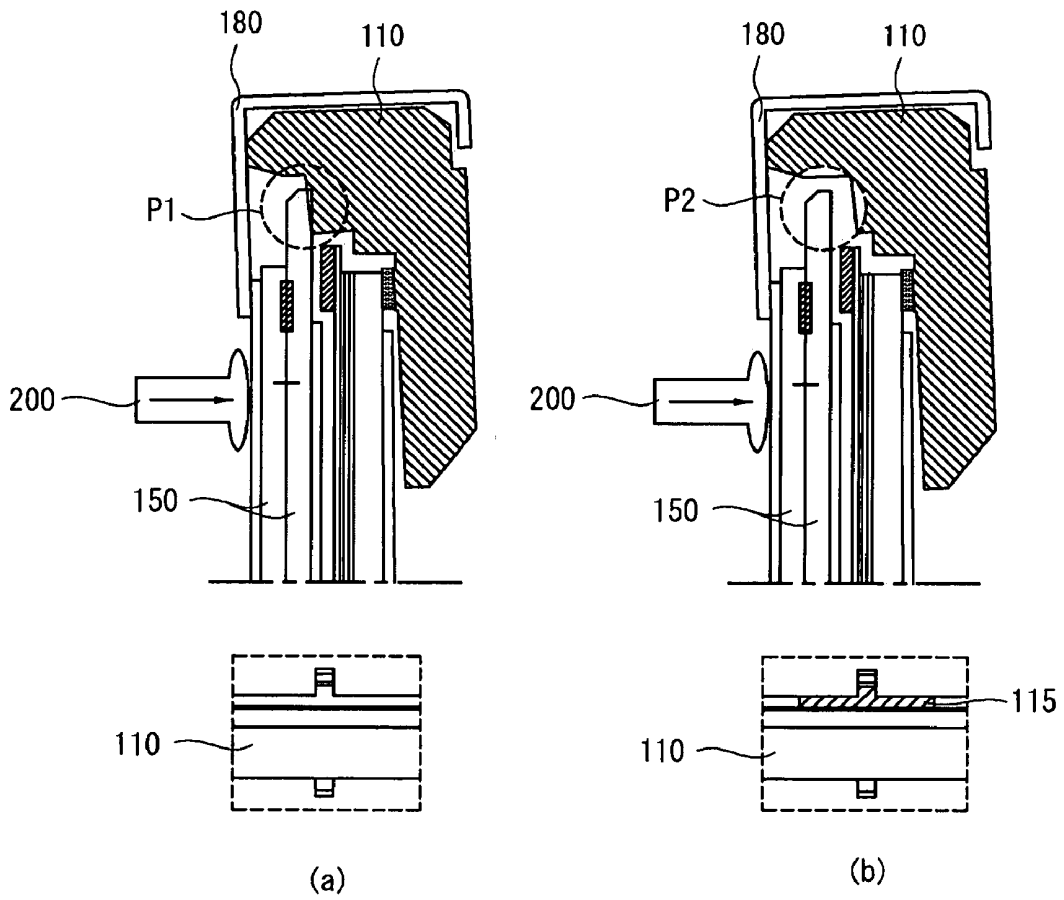

Fig. 6

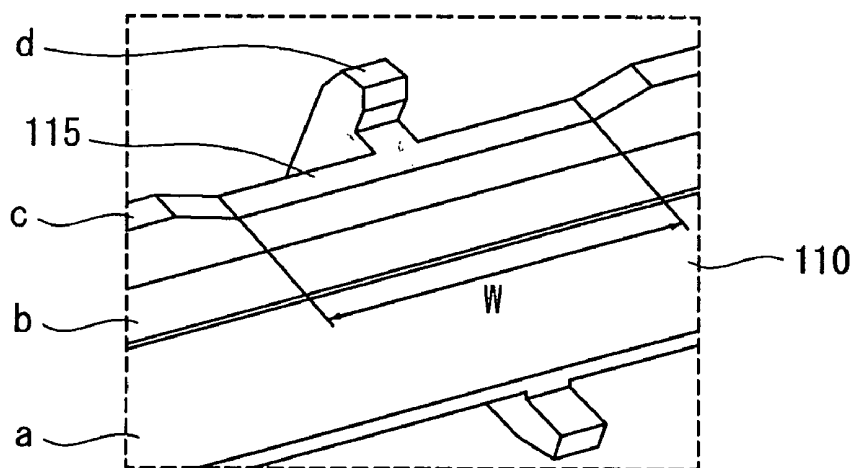

Fig. 7

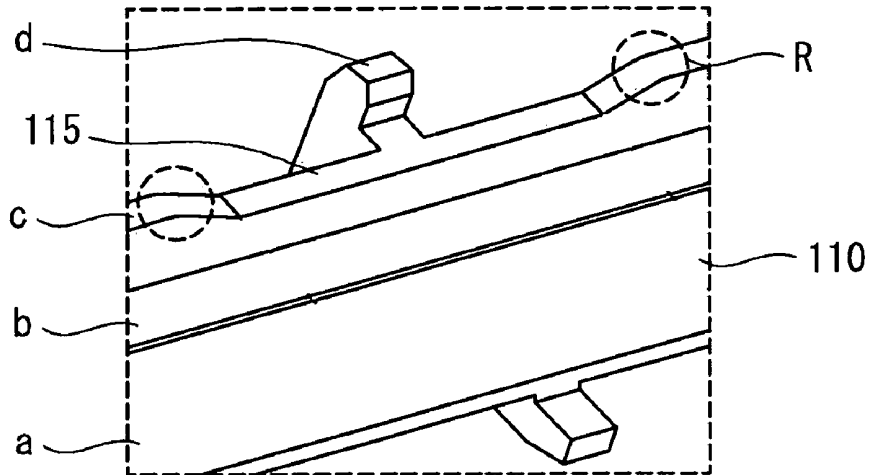
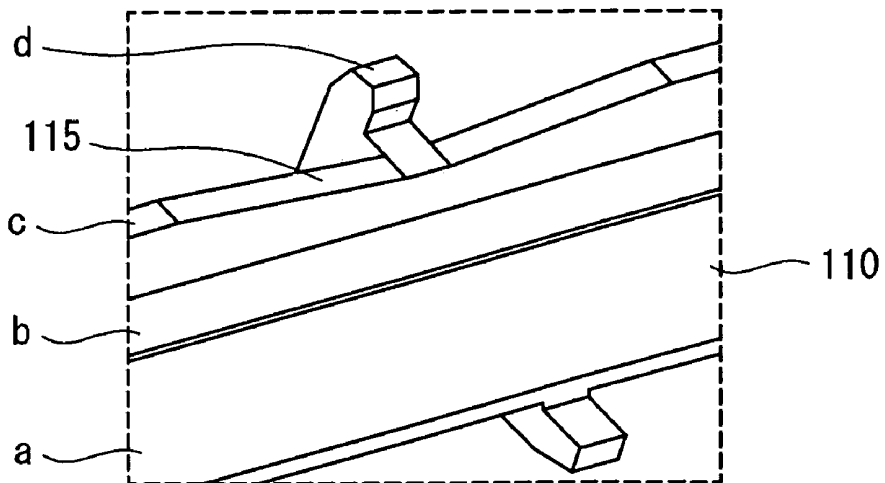

Fig. 8



LIQUID CRYSTAL DISPLAY

[0001] This application claims the benefit of Korean Patent Application No. 10-2008-0062853 filed on Jun. 30, 2008, which is hereby incorporated by reference for all purposes as if fully set forth herein.

BACKGROUND

[0002] 1. Field of the Invention

[0003] This document relates to a backlight unit and a liquid crystal display using the same.

[0004] 2. Discussion of the Related Art

[0005] As an information-oriented technology develops, a market of a display device, which is a connection medium between a user and information increases. Accordingly, a use of a flat panel display (FPD) such as a liquid crystal display (LCD), an organic light emitting diode (OLED), and a plasma display panel (PDP) increases. The LCD that can embody high resolution and that can increase a size as well as decrease a size is widely used.

[0006] The LCD is produced by dividing into a small module mounted in a mobile phone, or a digital camera, etc. and a large module mounted in a television, or a monitor, etc. The LCD is classified into a light receiving display device. The LCD receives light emitted from a light source of a backlight unit positioned at a lower part of a liquid crystal panel and expresses an image.

[0007] The LCD is largely divided into a transistor array substrate and a color filter substrate. In the transistor array substrate, a transistor including a gate, a semiconductor layer, a source, and a drain, and a subpixel including a pixel electrode that is connected to the source or the drain of the transistor are formed. A color filter and a black matrix are formed in the color filter substrate.

[0008] The liquid crystal panel and the backlight unit included in the LCD are received by a main support and an upper support. The main support has a plurality of step parts to receive the liquid crystal panel and the backlight unit. Because a related art main support is designed so that a step part facing the liquid crystal panel among a plurality of step parts contacts with the liquid crystal panel, when an impact test is performed, while the liquid crystal panel is bent, a light guide part of the upper support is opened and a light guide part of the main support is opened and thus interference between the liquid crystal panel and the main support occurs. Accordingly, a damage (crack) frequently occurs from a central area of the liquid crystal panel.

SUMMARY OF THE INVENTION

[0009] Accordingly, the present invention is directed to a liquid crystal display that substantially obviates one or more of the problems due to limitations and disadvantages of the related art.

[0010] Additional features and advantages of the invention will be set forth in the description which follows, and in part will be apparent from the description, or may be learned by practice of the invention. The objectives and other advantages of the invention will be realized and attained by the structure particularly pointed out in the written description and claims hereof as well as the appended drawings.

[0011] To achieve these and other advantages and in accordance with the purpose of the present invention, as embodied

and broadly described, an LCD includes: a liquid crystal panel; a backlight unit that includes a light guide plate that is positioned at a lower part of the liquid crystal panel and that guides light emitted from a light source in a direction of the liquid crystal panel, and a plurality of optical sheets that provide light emitted from the light guide plate to the liquid crystal panel; and a plurality of step parts that are formed from a base surface to an upper surface in order to receive the liquid crystal panel and the backlight unit, wherein a step part facing the liquid crystal panel among the plurality of step parts includes a main support having an area patterned to be apart from the liquid crystal panel.

[0012] It is to be understood that both the foregoing general description and the following detailed description are exemplary and explanatory and are intended to provide further explanation of the invention as claimed

BRIEF DESCRIPTION OF THE DRAWINGS

[0013] The accompanying drawings, which are included to provide a further understanding of the invention and are incorporated in and constitute a part of this specification, illustrate embodiments of the invention and together with the description serve to explain the principles of the invention.

[0014] FIG. 1 is a partial cross-sectional view of an LCD according to an embodiment of the present invention;

[0015] FIG. 2 is a schematic cross-sectional view of a liquid crystal panel shown in FIG. 1;

[0016] FIG. 3 is a partial perspective view of a main support shown in FIG. 1;

[0017] FIG. 4 is a view illustrating an impact test of a liquid crystal display module;

[0018] FIG. 5 is a view comparing the change within a liquid crystal display module by an impact test; and

[0019] FIGS. 6 to 8 are various perspective views of a main support according to a modified embodiment.

DETAILED DESCRIPTION OF THE ILLUSTRATED EMBODIMENTS

[0020] Reference will now be made in detail to an embodiment of the present invention, example of which is illustrated in the accompanying drawings.

[0021] As shown in FIG. 1, an LCD includes a liquid crystal panel 150. Further, the LCD includes backlight units 130 and 140 that include a light guide plate 130 that is positioned at a lower part of the liquid crystal panel 150 and that guides light emitted from a light source in a direction of the liquid crystal panel 150, and a plurality of optical sheets 140 for providing light emitted from the light guide plate 130 to the liquid crystal panel 150.

[0022] The LCD may include an adhesion member 120 for fixing the light guide plate 130 to one surface of the main support 110. The adhesion member 120 may use a double-sided tape to which an opaque material, for example, silver (Ag) or a black pigment is added.

[0023] Further, the LCD may include a reflective sheet 135 positioned between the light guide plate 130 and the main support 110. The LCD may use the reflective sheet 135 in which a diffusion material is formed in order to provide light emitted to the light guide plate 130 to a plurality of optical sheets 140 without loss.

[0024] Further, the LCD includes a black frame 170 for exposing a display area of the liquid crystal panel 150 and blocking a non-display area. The black frame 170 prevents

light emitted from the plurality of optical sheets **140** from being leaked to the outside. In order to improve light blocking characteristics, the black frame **170** may include an opaque black-series material and may be formed using a single layer film or a multiple layer film. The black frame **170** may be a light blocking tape.

[0025] Further, the LCD may include a polarizing film **160** positioned at both surfaces of the liquid crystal panel **150**. The polarizing film **160** may selectively include a plurality of films such as an anisotropic absorption shaft, a compensation film, and a zero retardation film according to a position in order to polarize light provided to the liquid crystal panel **150** and to emit only desired light in a direction of a display area.

[0026] Further, the LCD includes the liquid crystal panel **150** received in the main support **110** and an upper support **180** that protects the backlight units **130** and **140**. The upper support **180** may have an opening to expose a display area of the liquid crystal panel **150** and a form bent in a "c" shape. The plurality of optical sheets **140** may include at least one of a diffusion sheet, a prism sheet, a lenticular lens sheet, a micro lens sheet, and a protection sheet, and in order to increase a diffusion coefficient, beads may be included in at least one of a diffusion sheet, a prism sheet, a lenticular lens sheet, a micro lens sheet, and a protection sheet.

[0027] Referring to FIG. 2, the liquid crystal panel **150** is described in detail. A structure of the liquid crystal panel **150** shown in FIG. 2 is provided for a better understanding, and the liquid crystal panel **150** is not limited thereto.

[0028] The liquid crystal panel **150** may have a structure in which a first substrate **150a** in which a thin film transistor is formed and a second substrate **150b** in which a color filter is formed are coupled with a liquid crystal layer **Cl** interposed therebetween. According to characteristics of the liquid crystal layer **Cl**, an alignment film may be positioned in an upper part of the first substrate **150a** and the second substrate **150b**.

[0029] A gate **151** is positioned at one surface of the first substrate **150a**. The gate **151** may be formed of, for example, molybdenum (Mo), aluminum (Al), chrome (Cr), gold (Au), titanium (Ti), nickel (Ni), neodymium (Nd), and copper (Cu), or alloys thereof. Further, the gate **151** may be formed of multiple layers, such as multiple layers of molybdenum (Mo), aluminum (Al), chrome (Cr), gold (Au), titanium (Ti), nickel (Ni), neodymium (Nd), and copper (Cu), or alloys thereof. For example, the gate **151** may be formed in a double layer of molybdenum/aluminum-neodymium or molybdenum/aluminum.

[0030] The first insulating film **152** is positioned on the gate **151**. The first insulating film **152** may be a silicon oxide film (SiO_x), a silicon nitride film (SiN_x), or a multiple layer thereof, but is not limited thereto.

[0031] An active layer **154a** is positioned at an area corresponding to the gate **151** on the first insulating film **152**, and an ohmic contact layer **154b** for lowering contact resistance is positioned at the active layer **154a**. Further, a data wiring **153** for supplying a data voltage is positioned on the first insulating film **152**, but a position of the data wiring **153** is not limited thereto.

[0032] A source **155a** and a drain **155b** are positioned on the active layer **154a**. The source **155a** and the drain **155b** may be formed in a single layer or multiple layers, and when the source **155a** and the drain **155b** are formed in a single layer, the source **155a** and the drain **155b** may be formed of, for example, molybdenum (Mo), aluminum (Al), chrome (Cr), gold (Au), titanium (Ti), nickel (Ni), neodymium (Nd),

copper (Cu), or alloys thereof. The source **155a** and the drain **155b** may be formed of multiple layers, such as multiple layers of molybdenum (Mo), aluminum (Al), chrome (Cr), gold (Au), titanium (Ti), nickel (Ni), neodymium (Nd), and copper (Cu), or alloys thereof. For example, the source **155a** and the drain **155b** may be formed in a double layer of molybdenum/aluminum-neodymium, or a triple layer of molybdenum/aluminum/molybdenum or molybdenum/aluminum-neodymium/molybdenum.

[0033] A second insulating film **156** is positioned on the source **155a** and the drain **155b**. The second insulating film **156** may be a silicon oxide film (SiO_x), a silicon nitride film (SiN_x), or a multiple layers thereof, but is not limited thereto. The second insulating film **156** may be a passivation film.

[0034] A pixel electrode **157** connected to the source **155a** or the drain **155b** is positioned on the second insulating film **156**. The pixel electrode **157** may be a transparent electrode such as an indium tin oxide (ITO), an indium zinc oxide (IZO), or a zinc oxide (ZnO).

[0035] A common electrode (not shown) may be positioned opposite to the pixel electrode **157** on the second insulating film **156**. The common electrode may be positioned on the first substrate **150a** or the second substrate **150b**.

[0036] A spacer **158** for sustaining a cell gap with the second substrate **150b** is positioned on the second insulating film **156** that is positioned on the first substrate **150a** and that corresponds to the source **155a** and the drain **155b**.

[0037] A black matrix **BM** is positioned at one surface of the second substrate **150b**. The black matrix **BM** is positioned to correspond to a non-display area at which the spacer **158** is positioned. The black matrix **BM** may be made of a photo-sensitive organic material to which a black pigment is added, and the black pigment may use carbon black or titanium oxide, etc.

[0038] Color filters **CFR**, **CFG**, and **CFB** are positioned between the black matrixes **BM**. The color filters **CFR**, **CFG**, and **CFB** may have other colors as well as a red color **CFR**, a green color **CFG**, and a blue color **CFB**.

[0039] An overcoating layer **159** is positioned on the black matrix **BM** and the color filters **CFR**, **CFG**, and **CFB**. The second substrate **150b** in which the black matrix **BM** and the color filters **CFR**, **CFG**, and **CFB** are formed may omit the overcoating layer **159** according to a structure thereof.

[0040] Although not shown in FIG. 2, a driver including a scan driver and a data driver for supplying a driving signal to the liquid crystal panel **150** is positioned at the first substrate **150a**.

[0041] The driver is connected to the data wiring **153** and a gate wiring formed on the first substrate **150a** for forming the liquid crystal panel **150**. A film circuit in which the driver is mounted is connected to the liquid crystal panel **150** with a chip on film (COF) method or a tape carrier package (TCP) method. However, the driver may be directly mounted on the first substrate **150a** with a chip on glass (COG) method, or may be formed on the first substrate **150a** in a thin film transistor formation process.

[0042] The liquid crystal panel **150** formed in this way can display an image in each subpixel according to a scan signal supplied through gate wirings and a data voltage supplied through data wirings.

[0043] The scan signal may be a pulse signal in which a gate high voltage supplied for one horizontal time period and a gate low voltage supplied for the remaining time period are alternately supplied, but is not limited thereto. When a gate

high voltage is supplied from the gate wirings, a thin film transistor included in the subpixel is turned on to supply a data voltage applied from the data wirings to the liquid crystal layer Cl.

[0044] Accordingly, when the thin film transistor of each subpixel is turned on and a data voltage are thus applied to the pixel electrode 157, a difference voltage between a data voltage and a common voltage is charged to the liquid crystal layer Cl, and thus the liquid crystal panel 150 can display an image.

[0045] In contrast, when a gate low voltage is supplied from gate wirings, as the thin film transistor is turned off, a data voltage charged to the liquid crystal layer Cl may be sustained for one frame period by a storage capacitor. The liquid crystal panel 150 may repeat different operations according to a scan signal supplied through the gate wirings.

[0046] The main support 110 is described hereinafter in detail with reference to FIGS. 1 and 3. For a better understanding of description, FIG. 3 shows a partial area with a perspective view.

[0047] Referring to FIG. 1, as described above, the main support 110 includes a plurality of step parts a, b, c, and d formed from a base surface to an upper surface. The plurality of step parts a, b, c, and d include a first step part a, a second step part b, a third step part c, and a fourth step part d. The third step part c is formed so that an area facing the liquid crystal panel 150 is disposed apart. The first step part a supports the reflective sheet 135 and the light guide plate 130, the second step part b supports the optical sheet 140, the third step part c supports the liquid crystal panel 150, and the fourth step part d supports the upper support 180. The fourth step part d may be a rip part.

[0048] In order to separate the liquid crystal panel 150 and the main support 110 from each other, the third step part c facing the liquid crystal panel 150 has an area 115 patterned to be depressed. The patterned area 115 may be depressed in a substantially rectangular form. Further, the patterned area 115 may have a width W narrower than that of a surface of the third step part c.

[0049] The patterned area 115 is positioned at a rip part area positioned at the center of the main support 110. The reason for forming the patterned area 115 in a rip part area of the main support 110 is that a central area of the liquid crystal panel 150 is frequently damaged (cracked) when the main support 110 and the upper support 180 are manufactured in a module form by coupling and an impact test that applies an external force to the module is performed.

[0050] As shown in FIG. 4, an impact test is performed by putting the liquid crystal display module 100 in a mount 300 and applying an impact corresponding to a predetermined weight with a push pull gauge or a cotton hammer 200 to the liquid crystal display module 100. The impact test method may be performed on a portion basis by dividing into an area such as an upper portion of a rip part of the liquid crystal display module 100.

[0051] Referring to FIG. 5, when the impact test of FIG. 4 was performed, in a case of FIG. 5(a), while the liquid crystal panel 150 is bent, as the upper support 180 and the main support 110 are opened, interference occurs between the liquid crystal panel 150 and the main support 110 and thus a damage (crack) occurs from a central area of the liquid crystal panel 150 (see P1).

[0052] When the impact test of FIG. 4 was performed, in a case of FIG. 5(b), while the liquid crystal panel 150 is bent,

even if the upper support 180 and the main support 110 are opened, interference does not occur between the liquid crystal panel 150 and the main support 110 and thus the liquid crystal panel 150 is not damaged (cracked) (see P2).

[0053] As an experiment result, in a structure of FIG. 5(a), upon an impact test, the liquid crystal panel 150 was damaged by an impact corresponding to about 6 kg, but in a structure of FIG. 5(b), upon an impact test, even if an impact corresponding to about 16 kg is applied, the liquid crystal panel 150 was not damaged.

[0054] A shape of the main support 110 is not limited thereto and may be formed in a form of FIG. 6.

[0055] Referring to FIG. 6, the patterned area 115 positioned at a central rip part area of the main support 110 is depressed in a substantially rectangular form, and a surrounding area of the patterned area 115 may have an inclined slope surface. Further, the third step part c formed in the main support 110 of FIG. 6 may have a height equal to or lower than that of the black frame 170.

[0056] Referring to FIG. 7, the patterned area 115 positioned at a central rip part area of the main support 110 is depressed in a substantially rectangular form, and an upper corner area of an inclined slope surface positioned at a surrounding area of the patterned area 115 may have a round shape R. In this case, because an upper corner area of both slope surfaces of the patterned area 115 is formed in a round shape R, upon an impact test, a degree of an impact transferred to the liquid crystal panel may be mitigated. Further, the third step part c formed in the main support 110 of FIG. 7 may have a height equal to or lower than that of the black frame 170.

[0057] Referring to FIG. 8, the patterned area 115 positioned at a central rip area of the main support 110 may have a slope surface inclined toward the center of the patterned area 115. In such a structure, an upper corner area of both slope surfaces of the patterned area 115 may be formed in a round shape, as shown in FIG. 7. Further, the third step part c formed in the main support 110 of FIG. 8 may have a height equal to or lower than that of the black frame 170.

[0058] As described above, by improving a step part structure of a main support that receives a liquid crystal panel with a lower cost, upon an impact test, an LCD that can solve a problem that a liquid crystal panel is damaged (cracked) by an external force is provided. Therefore, by improving a damage (crack) resisting force to an external force, an LCD stronger on an impact than a related art LCD is provided. Further, by changing a step part structure of a main support, an LCD that can satisfy an impact test specification requested by a buyer is provided.

[0059] It will be apparent to those skilled in the art that various modifications and variations can be made in the present invention without departing from the spirit or scope of the invention. Thus, it is intended that the present invention cover the modifications and variations of this invention provided they come within the scope of the appended claims and their equivalents.

What is claimed is:

1. A liquid crystal display (LCD) comprising:
 - a liquid crystal panel;
 - a backlight unit that comprises a light guide plate that is positioned at a lower part of the liquid crystal panel and that guides light emitted from a light source in a direction of the liquid crystal panel, and a plurality of optical

sheets that provide light emitted from the light guide plate to the liquid crystal panel; and
a plurality of step parts that are formed from a base surface to an upper surface in order to receive the liquid crystal panel and the backlight unit,
wherein a step part facing the liquid crystal panel among the plurality of step parts comprises a main support having an area patterned to be apart from the liquid crystal panel.

2. The LCD of claim 1, wherein the patterned area is a rip area that is positioned at the center of the main support.
3. The LCD of claim 1, wherein the patterned area has a depressed pattern.
4. The LCD of claim 1, wherein the patterned area is depressed in a rectangular form.

5. The LCD of claim 4, wherein a surrounding area of the patterned area has an inclined slope surface.
6. The LCD of claim 5, wherein an upper corner area of the inclined slope surface has a round shape.
7. The LCD of claim 1, wherein the patterned area has a slope surface inclined toward the center of the patterned area.
8. The LCD of claim 1, wherein a width of the patterned area is narrower than that of a surface of a step part facing the liquid crystal panel.
9. The LCD of claim 1, wherein a black frame for exposing a display area of the liquid crystal panel and blocking a non-display area thereof is positioned between the liquid crystal panel and the plurality of optical sheets.
10. The LCD of claim 9, wherein a height of the patterned area is equal to or lower than that of the black frame.

* * * * *

专利名称(译)	液晶显示器		
公开(公告)号	US20090322989A1	公开(公告)日	2009-12-31
申请号	US12/318518	申请日	2008-12-30
[标]申请(专利权)人(译)	KIM HYOJIN KIM HYUNKI		
申请(专利权)人(译)	KIM HYOJIN KIM HYUNKI		
当前申请(专利权)人(译)	KIM HYOJIN KIM HYUNKI		
[标]发明人	KIM HYOJIN KIM HYUNKI		
发明人	KIM, HYOJIN KIM, HYUNKI		
IPC分类号	G02F1/13357		
CPC分类号	G02F1/133308 G02F2201/503 G02F2001/133317 G02F1/133608		
优先权	1020080062853 2008-06-30 KR		
其他公开文献	US8049831		
外部链接	Espacenet USPTO		

摘要(译)

液晶显示器包括：液晶面板；背光单元，包括导光板和多个光学片，所述导光板位于所述液晶面板的下部，所述导光板沿着所述液晶面板的方向引导从光源发出的光，所述多个光学片提供从所述液晶面板的方向发射的光。导光板到液晶面板；多个台阶部分，从基面到上表面形成，以接收液晶面板和背光单元，其中，多个台阶部分中面向液晶面板的台阶部分包括主支撑件图案化为远离液晶面板的区域。

