



US007898518B2

(12) **United States Patent**  
**Hong et al.**

(10) **Patent No.:** **US 7,898,518 B2**  
(45) **Date of Patent:** **\*Mar. 1, 2011**

(54) **LIQUID CRYSTAL DISPLAY AND METHOD OF DRIVING THE SAME**

(58) **Field of Classification Search** ..... 345/87-90,  
345/94, 95, 98-100  
See application file for complete search history.

(75) Inventors: **Jincheol Hong**, Paju-si (KR); **Pilsung Kang**, Paju-si (KR); **Mangyu Park**, Seoul (KR); **Geunwoo Koh**, Kyungbuk (KR)

(56) **References Cited**

U.S. PATENT DOCUMENTS

2010/0148829	A1 *	6/2010	Hong et al.	327/108
2010/0149083	A1 *	6/2010	Park et al.	345/99
2010/0156879	A1 *	6/2010	Hong et al.	345/213
2010/0156885	A1 *	6/2010	Cho et al.	345/214

(73) Assignee: **LG Display Co., Ltd.**, Seoul (KR)

(\*) Notice: Subject to any disclaimer, the term of this patent is extended or adjusted under 35 U.S.C. 154(b) by 0 days.

\* cited by examiner

*Primary Examiner* — Ricardo L Osorio

This patent is subject to a terminal disclaimer.

(74) *Attorney, Agent, or Firm* — McKenna Long & Aldridge LLP

(21) Appl. No.: **12/461,652**

(57) **ABSTRACT**

(22) Filed: **Aug. 19, 2009**

A liquid crystal display and a method of driving the same are disclosed. The liquid crystal display includes a timing controller, N source drive integrated circuits (ICs), where N is an integer equal to or greater than 2, N pairs of data bus lines, each of which connects the timing controller to each of the N source drive ICs in a point-to-point manner, a lock check line that connects a first source drive IC of the N source drive ICs to the timing controller and cascade-connects the N source drive ICs to one another, and a feedback lock check line that connects a last source drive IC of the N source drive ICs to the timing controller.

(65) **Prior Publication Data**

US 2010/0149082 A1 Jun. 17, 2010

(30) **Foreign Application Priority Data**

Dec. 15, 2008 (KR) ..... 10-2008-0127456

(51) **Int. Cl.**  
**G09G 3/36** (2006.01)

**20 Claims, 24 Drawing Sheets**

(52) **U.S. Cl.** ..... 345/99; 345/100

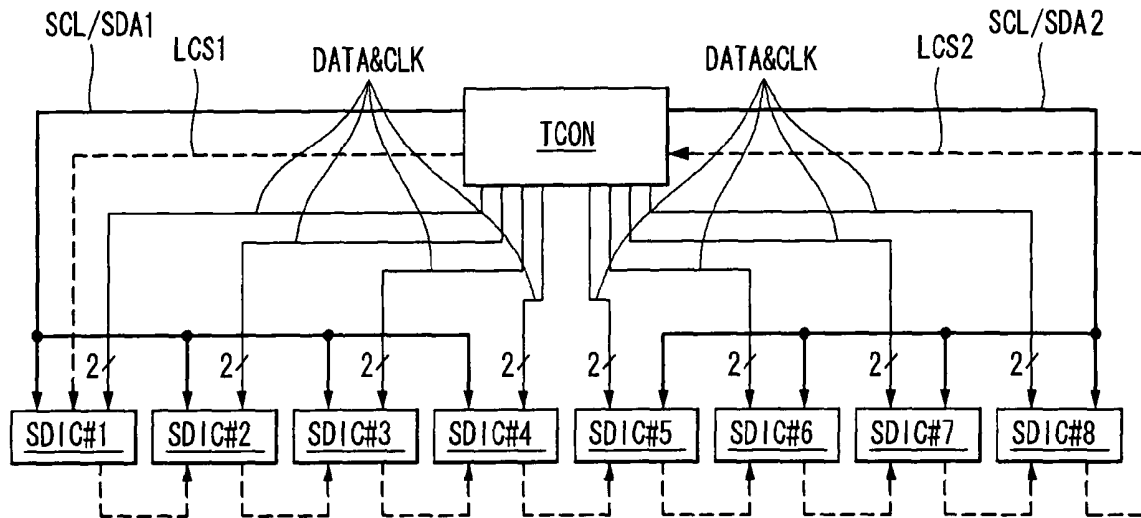

FIG. 1

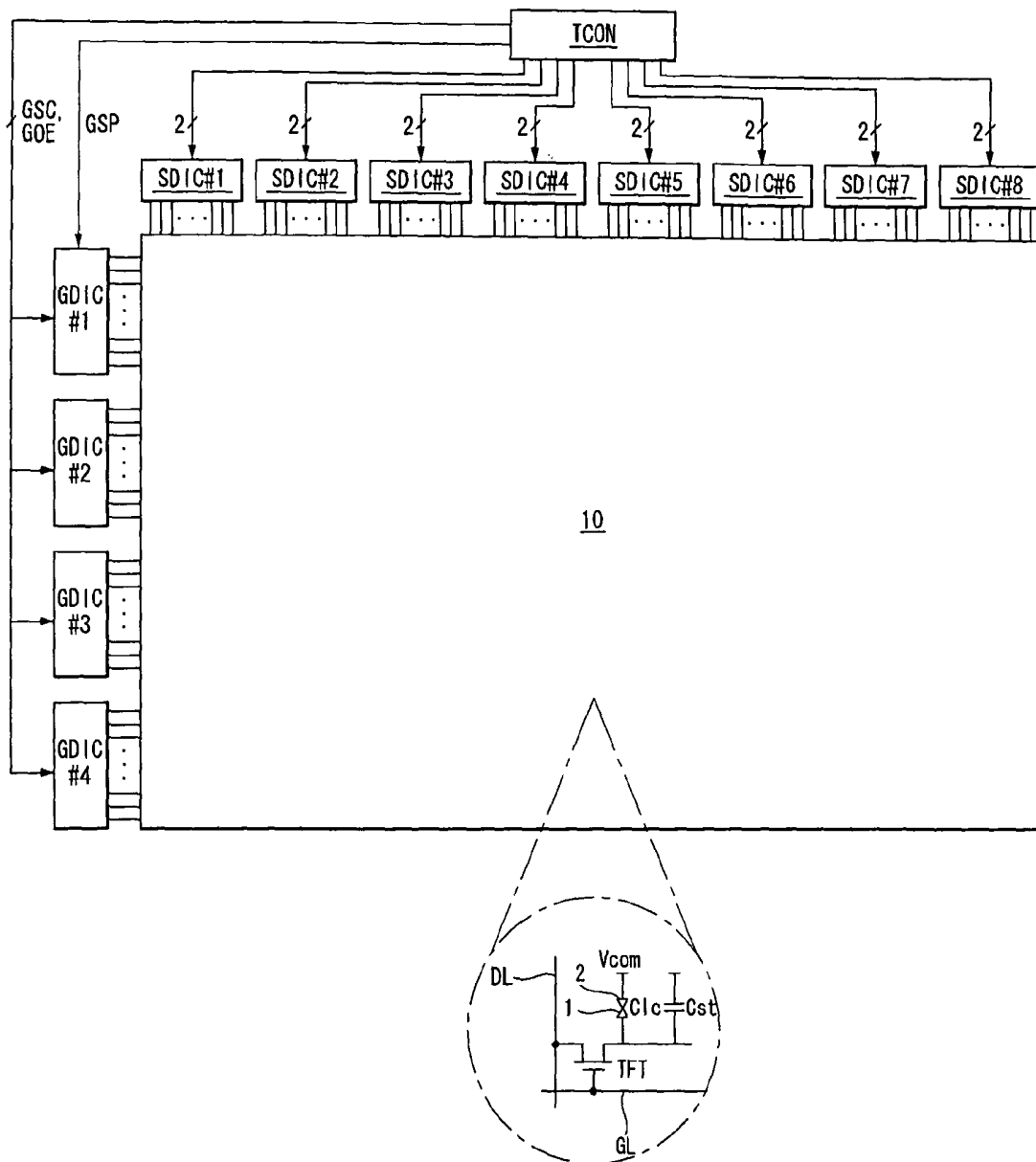
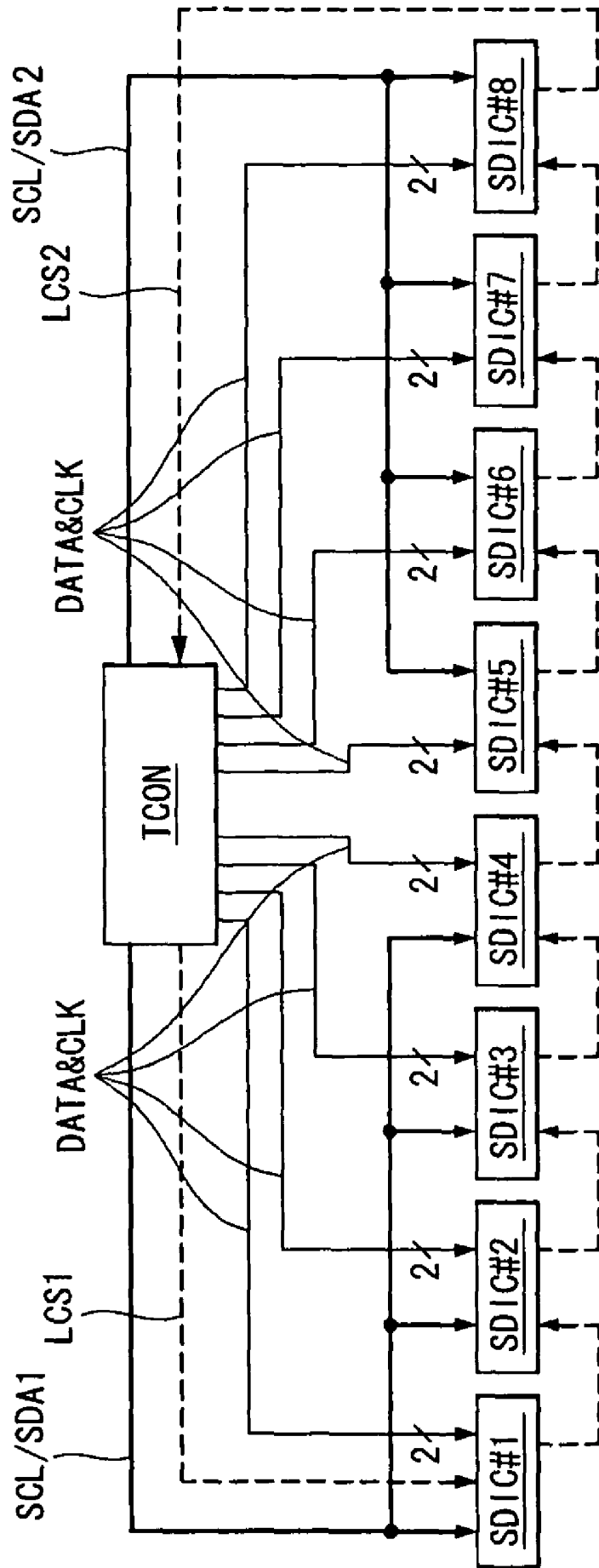

FIG. 2



**FIG. 3**

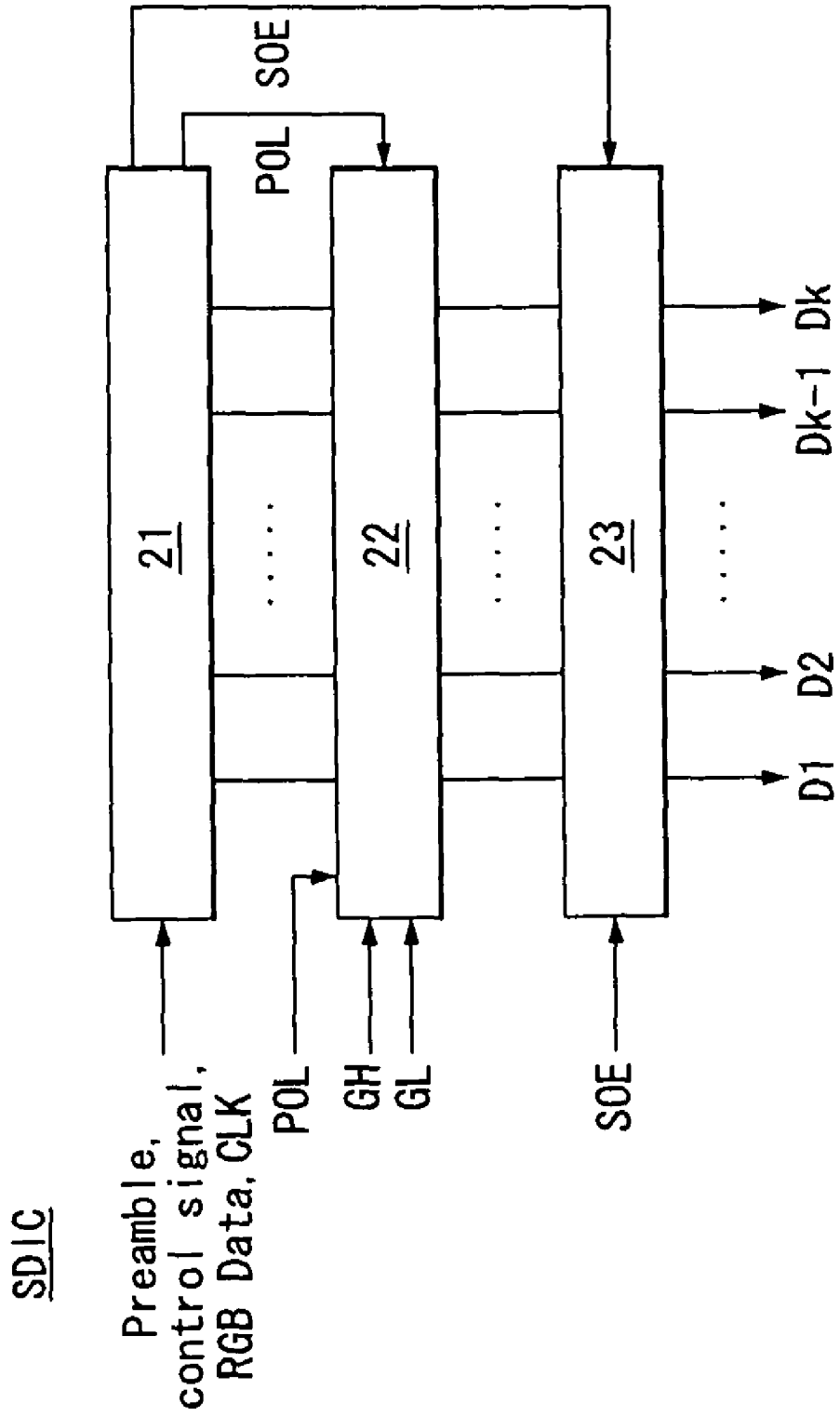
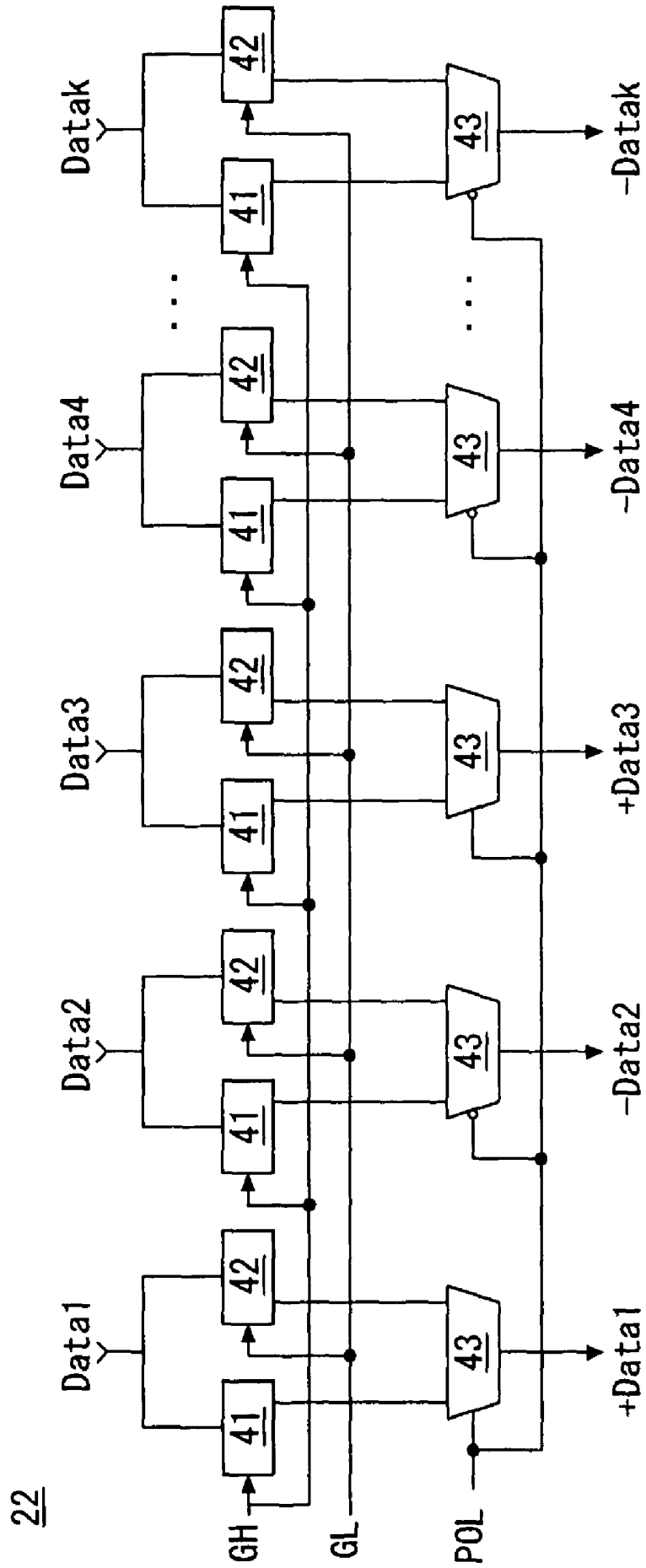

FIG. 4



22

FIG. 5

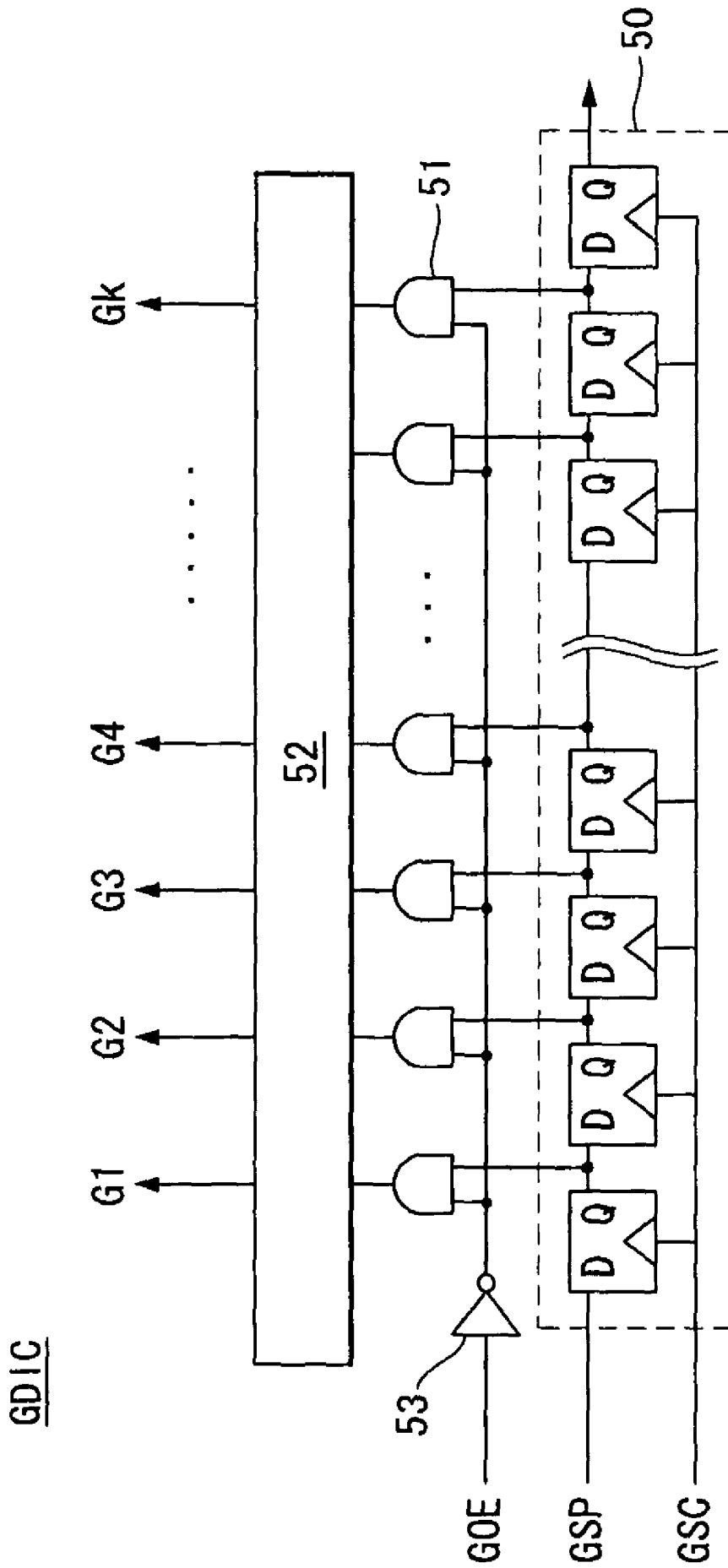

FIG. 6

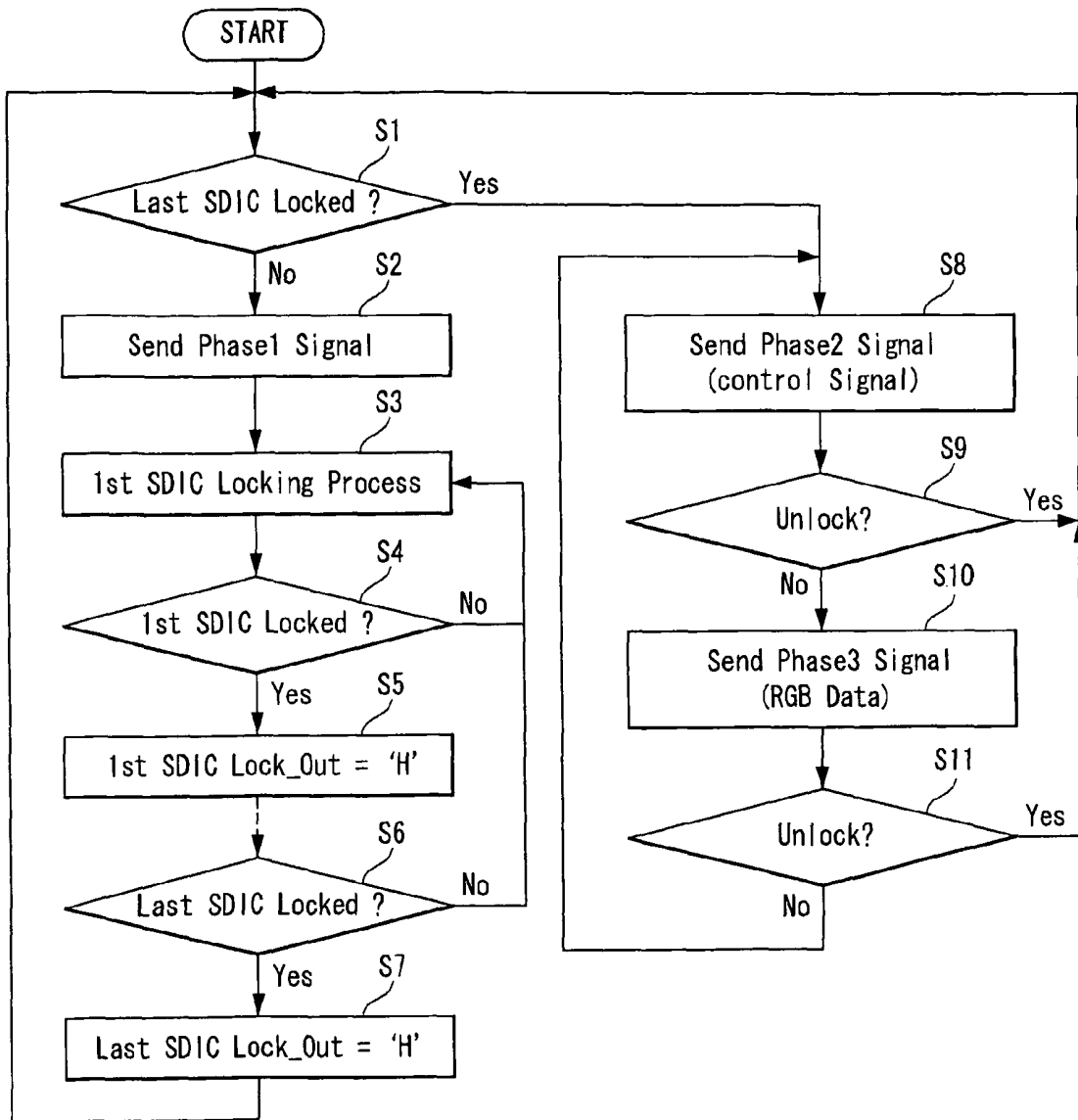

FIG. 7

21

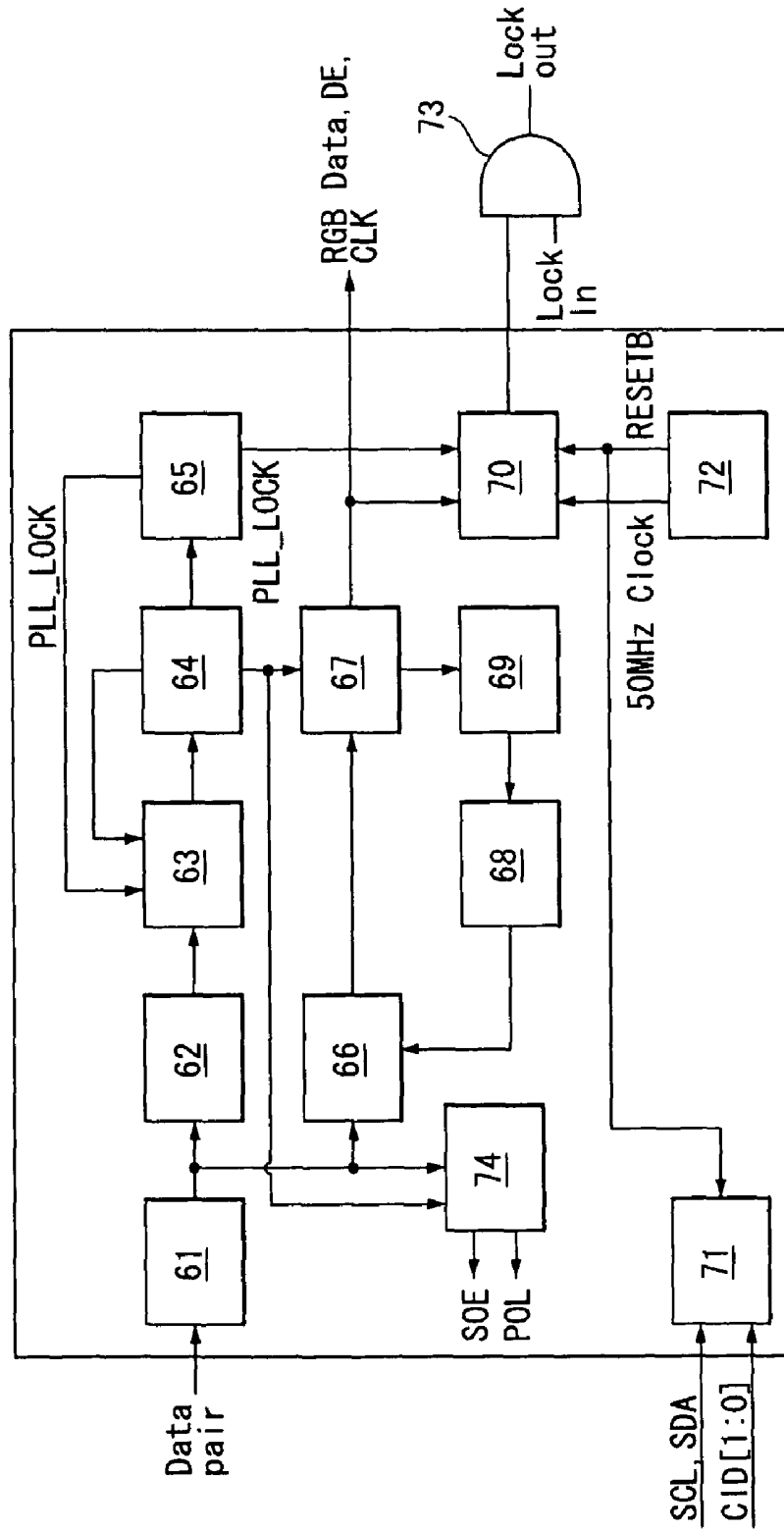

FIG. 8

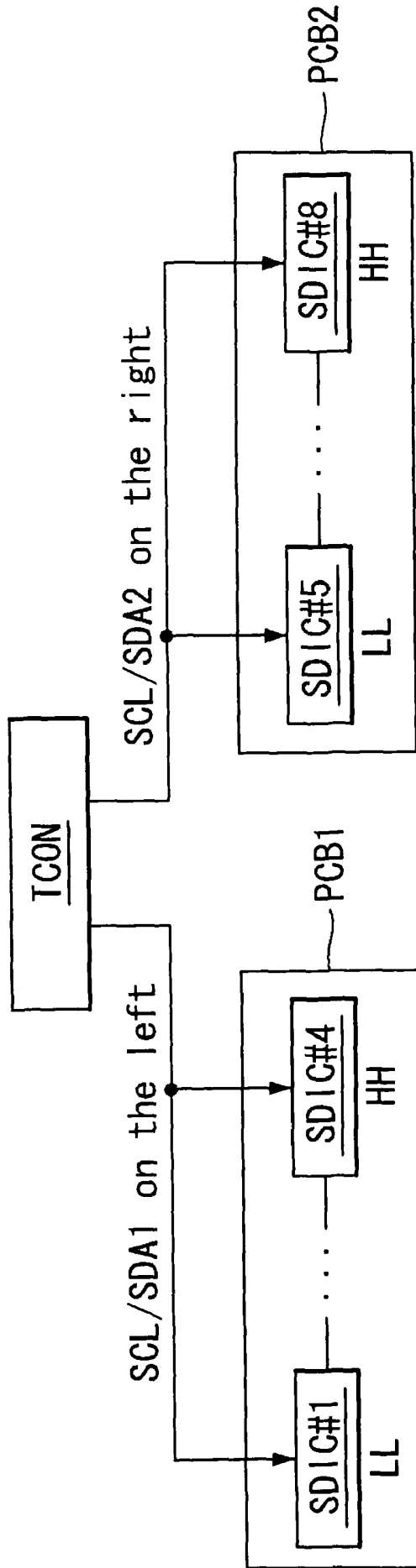

FIG. 9

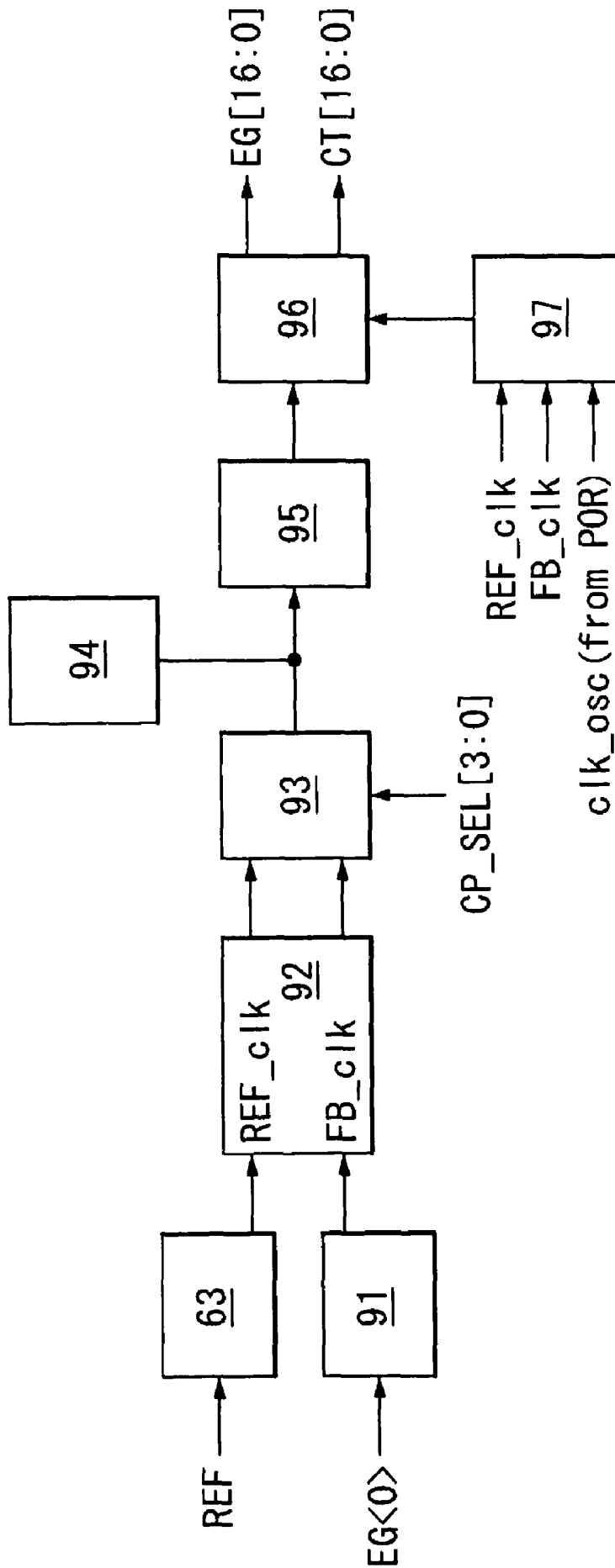

FIG. 10

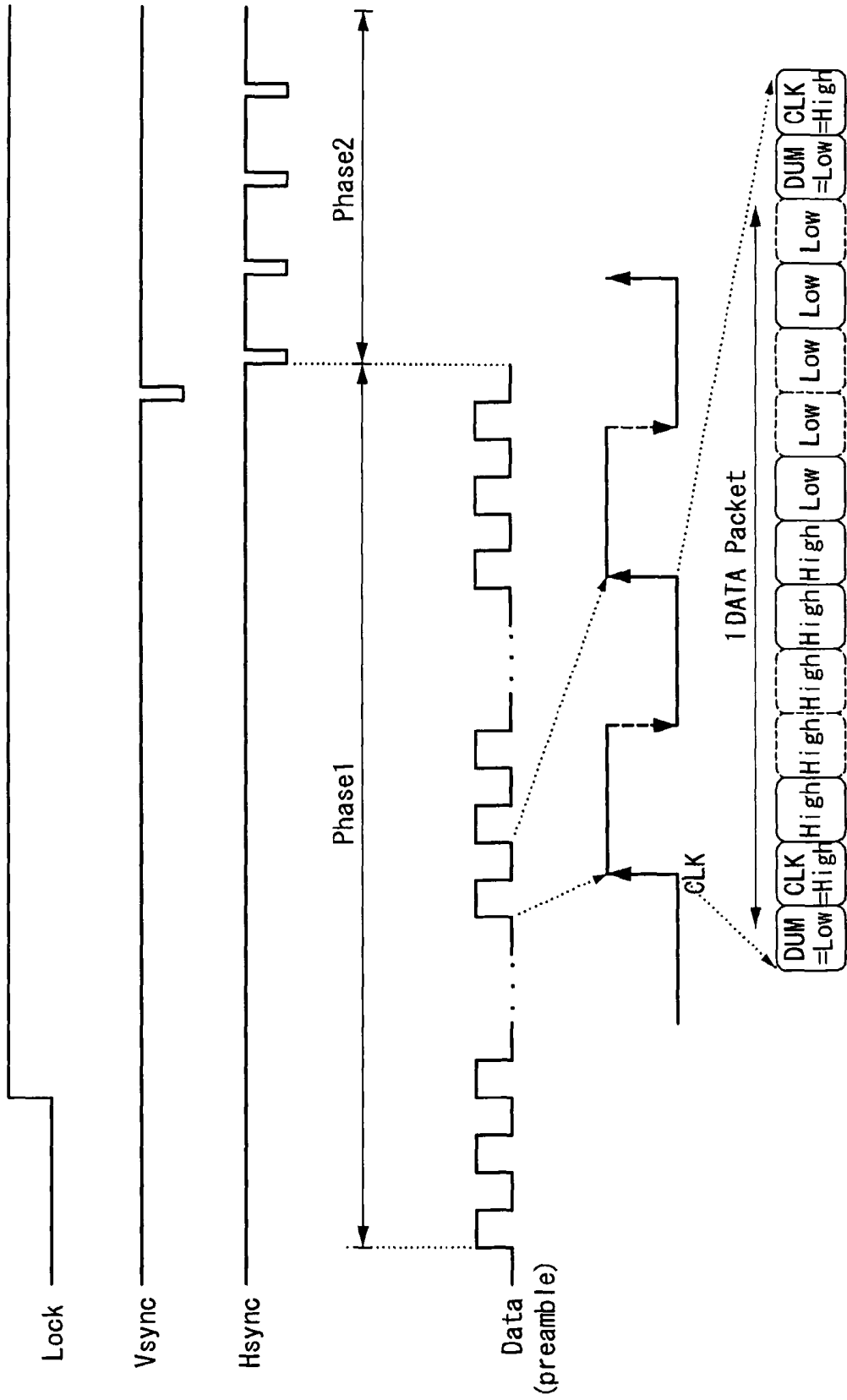

FIG. 11

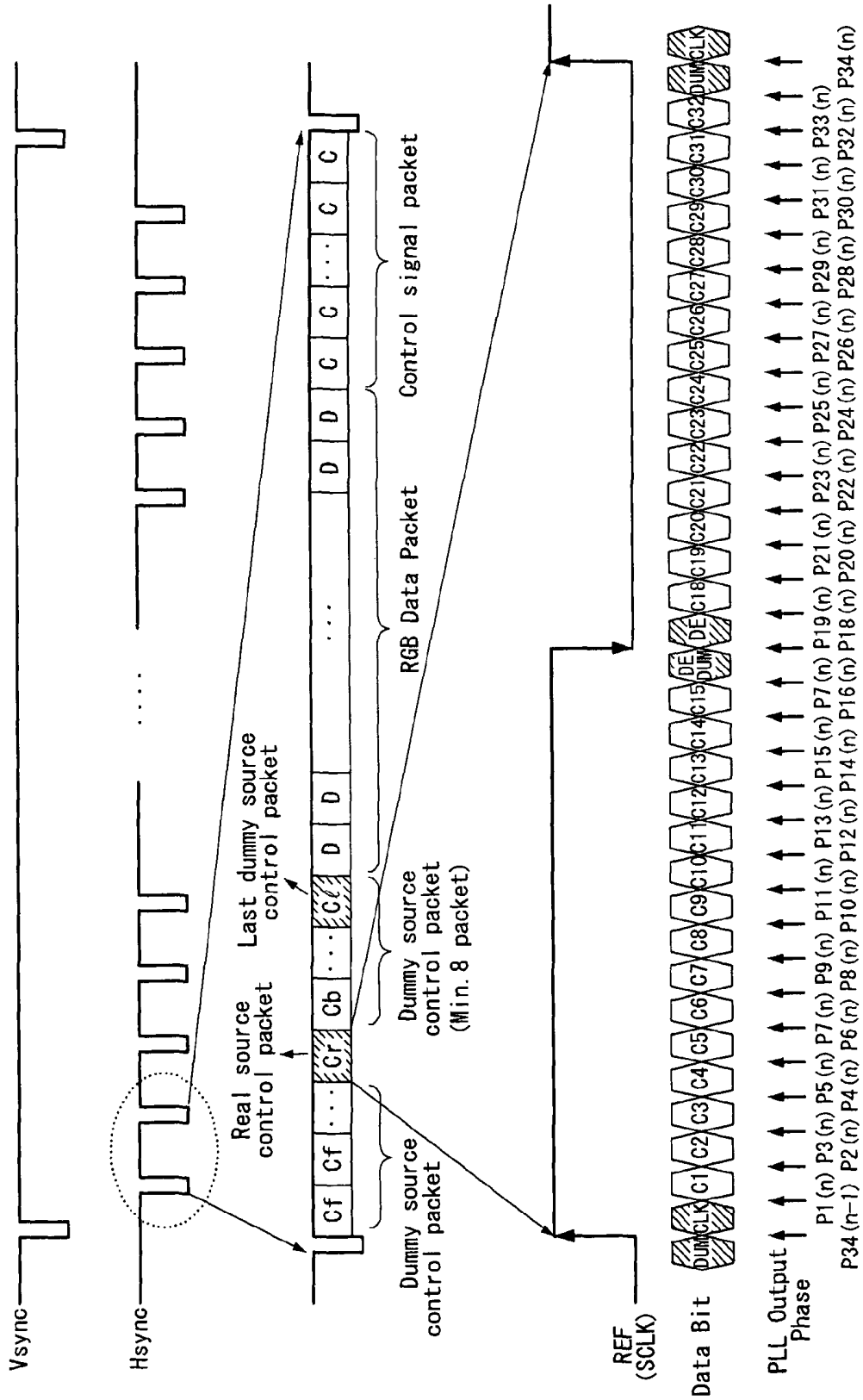

FIG. 12

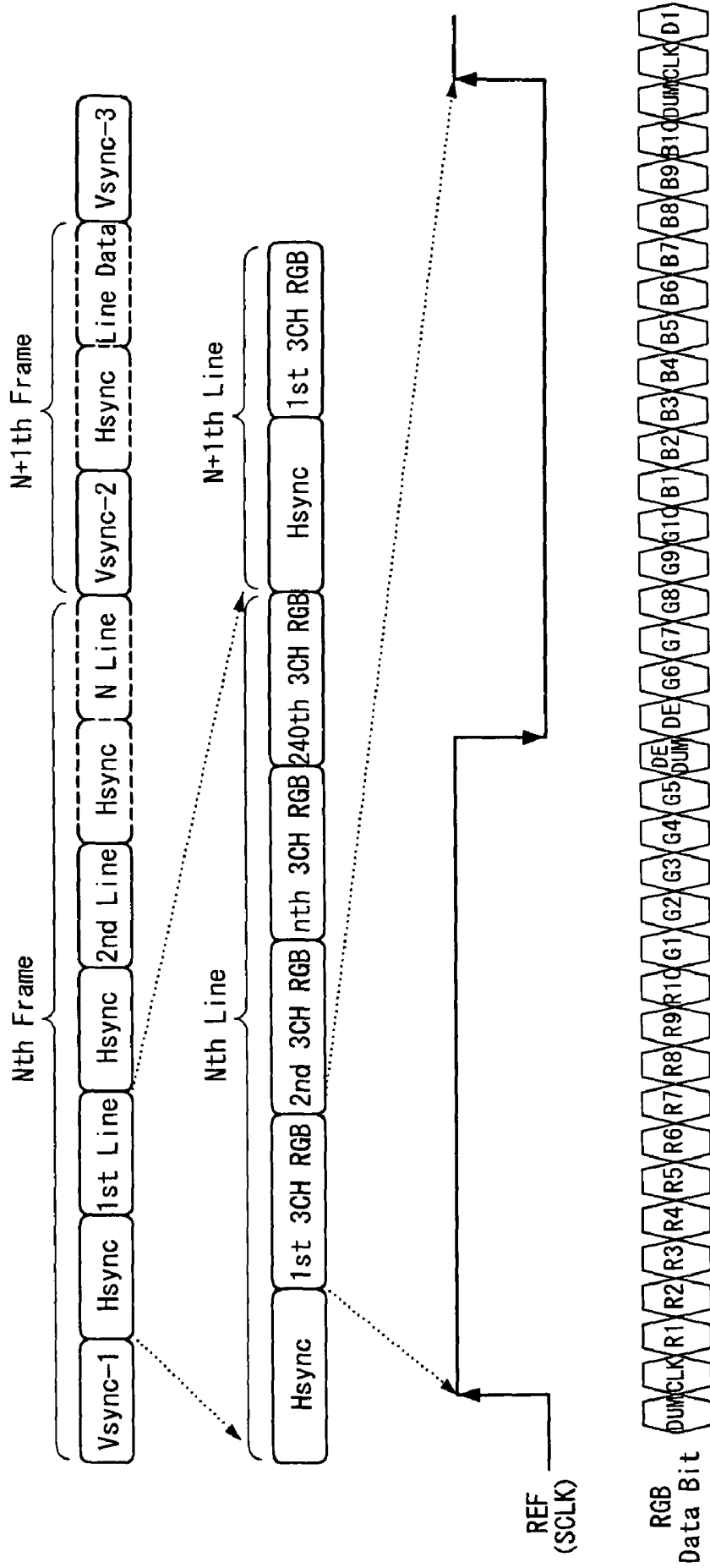

FIG. 13

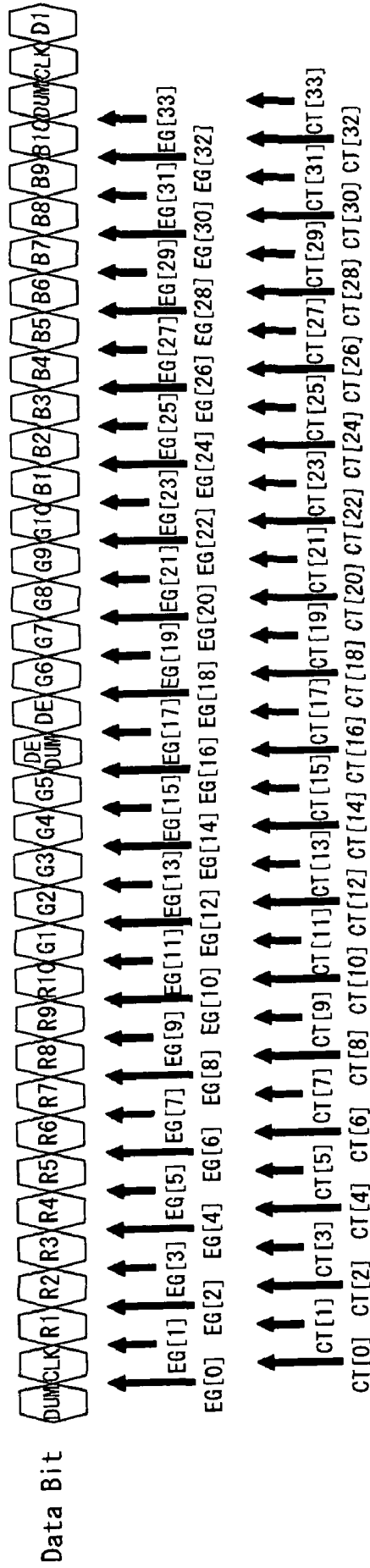
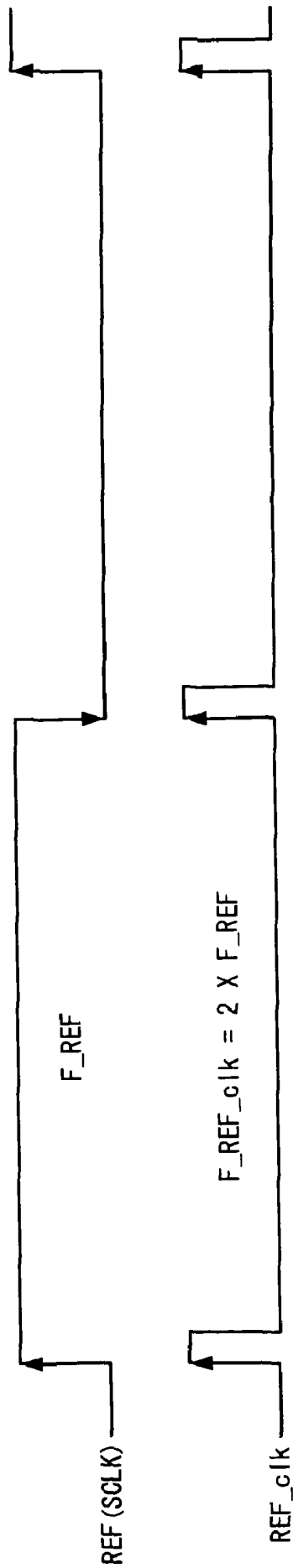

FIG. 14

Data Bit	CLK	D1~D10	D11~D15	DE_DUM	DE	D16~D20	D21~D30
Format	Clock	R_data[0:9]	G_data[0:4]	DUMMY	Data Enable	G_data[5:9]	B_data[0:9]
	Clock	Control Data (C1~C15)		DUMMY	Data Enable	Control Data (C18~C32)	

FIG. 15

Items	C0	C1	C2	C3	C12~C11	C12	C13~C14	C15	C16	C17	C18~C32
Dummy source control packet Cf, Cb	H	L	L	L	Assigned	L	Assigned	H	H	L	
Real source control packet Cr	H	(H H)	L	L	Assigned	L	Assigned	H	H	L	
Last dummy source control packet C1	H	L	L	L	Assigned	L	Assigned	H	(L H)	(L H)	
Control signal Mapping	CLK	SOE		SOE PRD			POL		DE		

FIG. 16

Position		Items	Description
CLK	C0		-
R0	C1	DUM_SOE	Dummy signal for SOE
R1	C2	SOE	Strobe Output Enable
R2	C3	Reserved	-
R3	C4	DUM_SOE_PRD0	Dummy signal for SOE_PRD0
R4	C5	SOE_PRD0	Control SOE Period
R5	C6	DUM_SOE_PRD1	Dummy signal for SOE_PRD1
R6	C7	SOE_PRD1	Control SOE Period
R7	C8	DUM_SOE_PRD2	Dummy signal for SOE_PRD2
R8	C9	SOE_PRD2	Control SOE Period
R9	C10	DUM_SOE_PRD3	Dummy signal for SOE_PRD3
G0	C11	SOE_PRD3	Control SOE Period
G1	C12	Reserved	-
G2	C13	DUM_POL	Dummy signal for POL
G3	C14	POL	Strobe polarity control.
G4	C15	Reserved	-
DE_DUM	C16	DUM_DE	-
DE	C17	Data Enable	Control/RGB Signal Selection
G4~G9 B0~B9	C18~C32	Reserved	-

FIG. 17

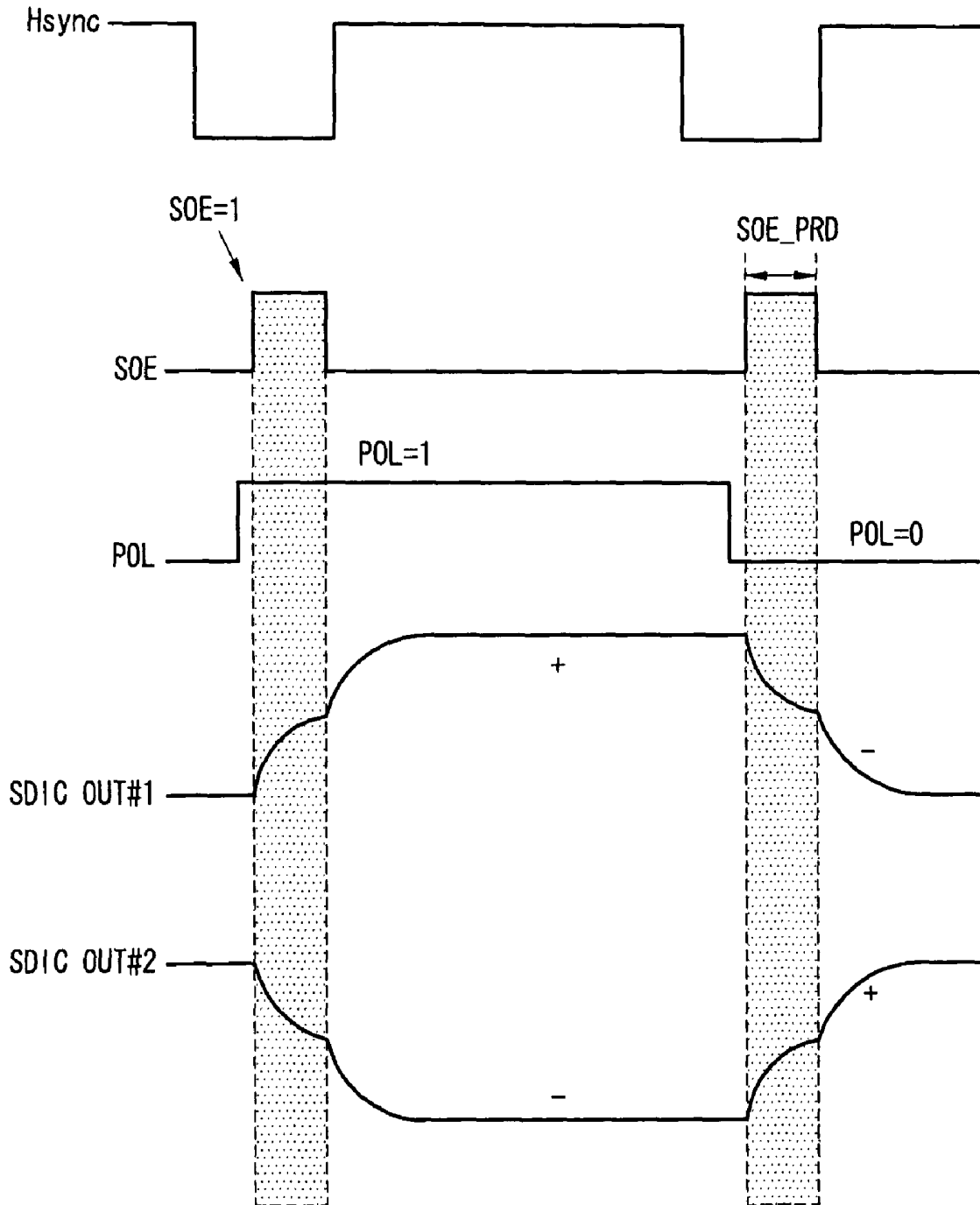

**FIG. 18**

SOE_PRD<3:0>	SOE High Period
0000	SCLK x 4
0001	SCLK x 8
0010	SCLK x 12
0011	SCLK x 16
0100	SCLK x 20
0101	SCLK x 24
0110	SCLK x 28
0111	SCLK x 32
1000	SCLK x 36
1001	SCLK x 40
1010	SCLK x 44
1011	SCLK x 48
1100	SCLK x 52
1101	SCLK x 56
1110	SCLK x 60
1111	SCLK x 64

FIG. 19

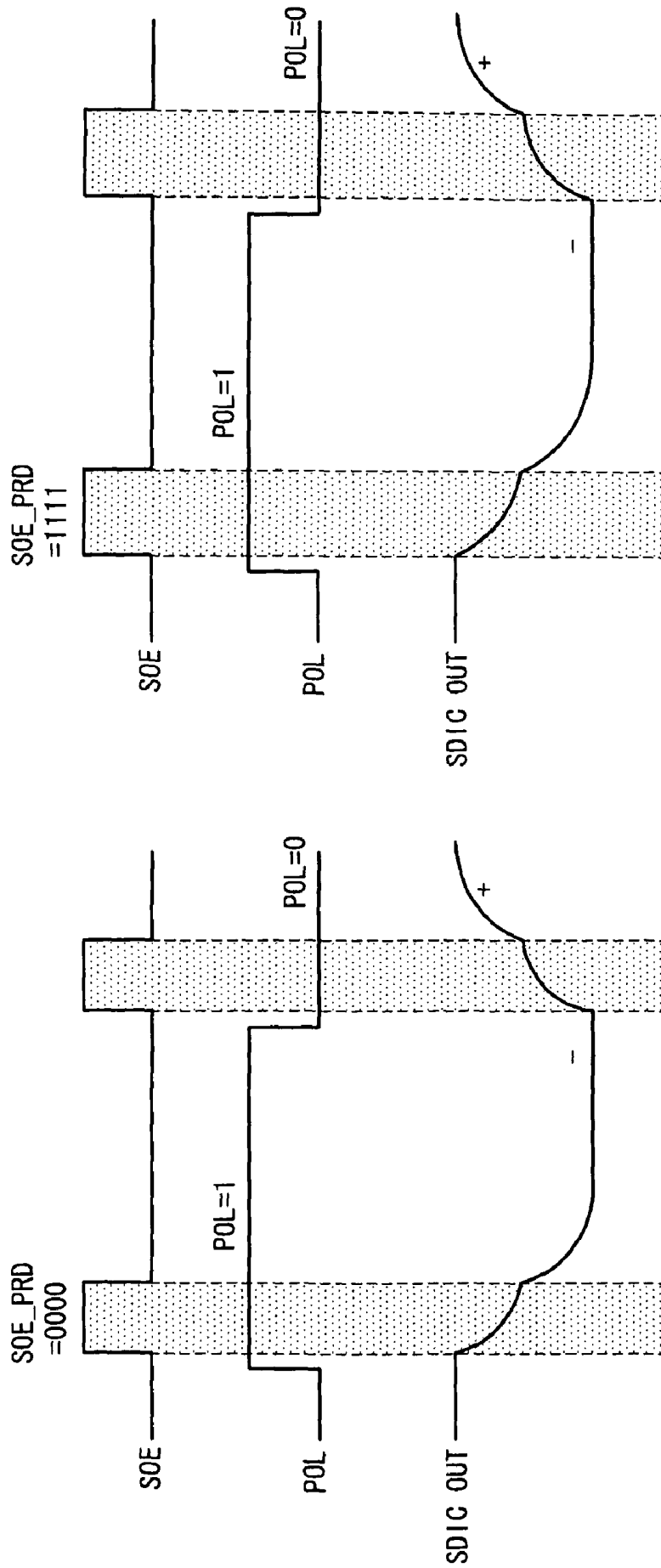

FIG. 20

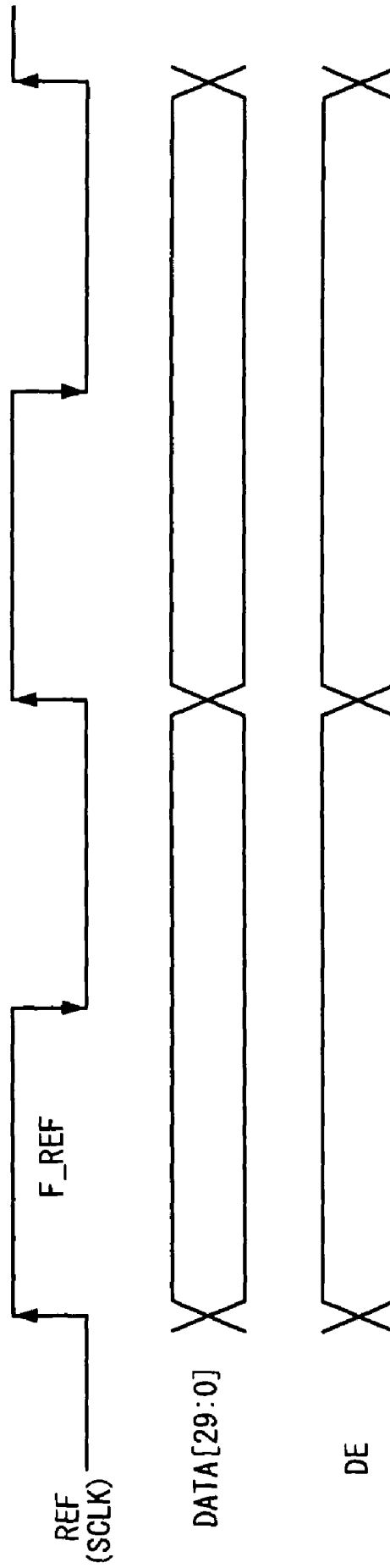

FIG. 21A

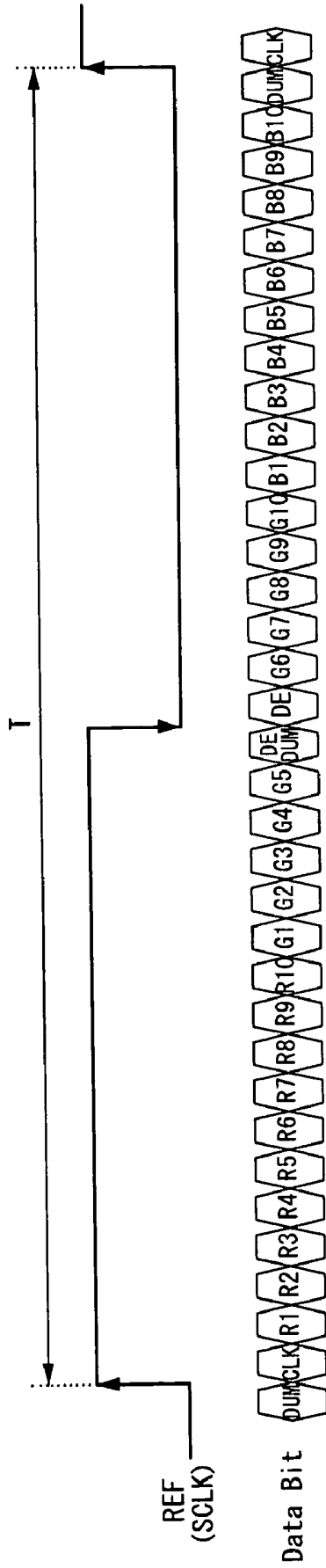

FIG. 21B

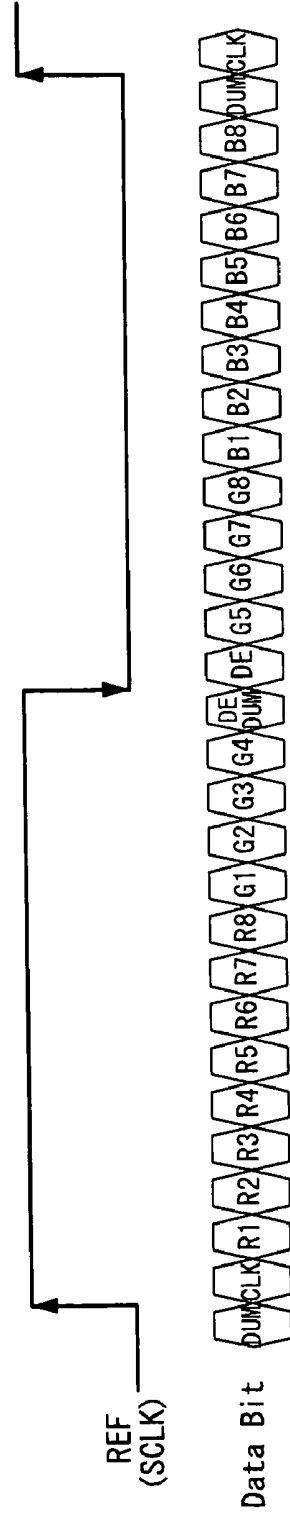

FIG. 21C

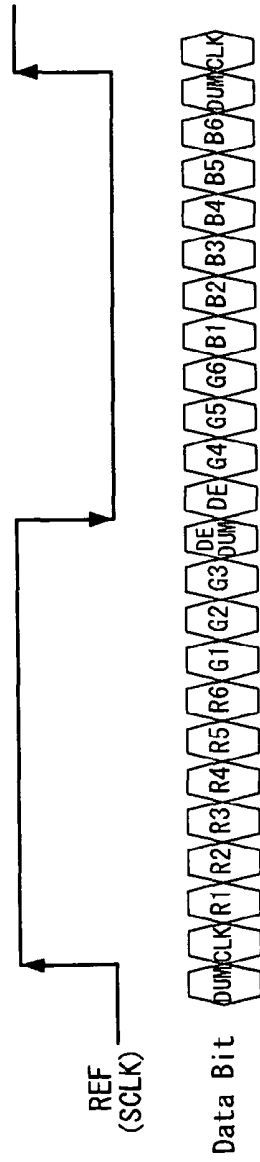

FIG. 21D

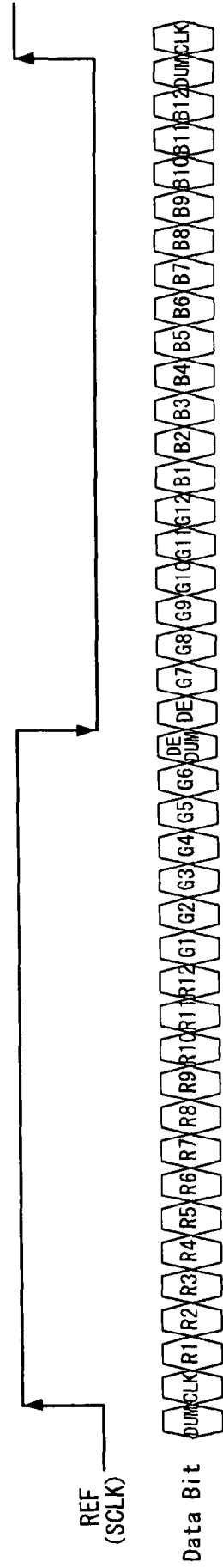



FIG. 23

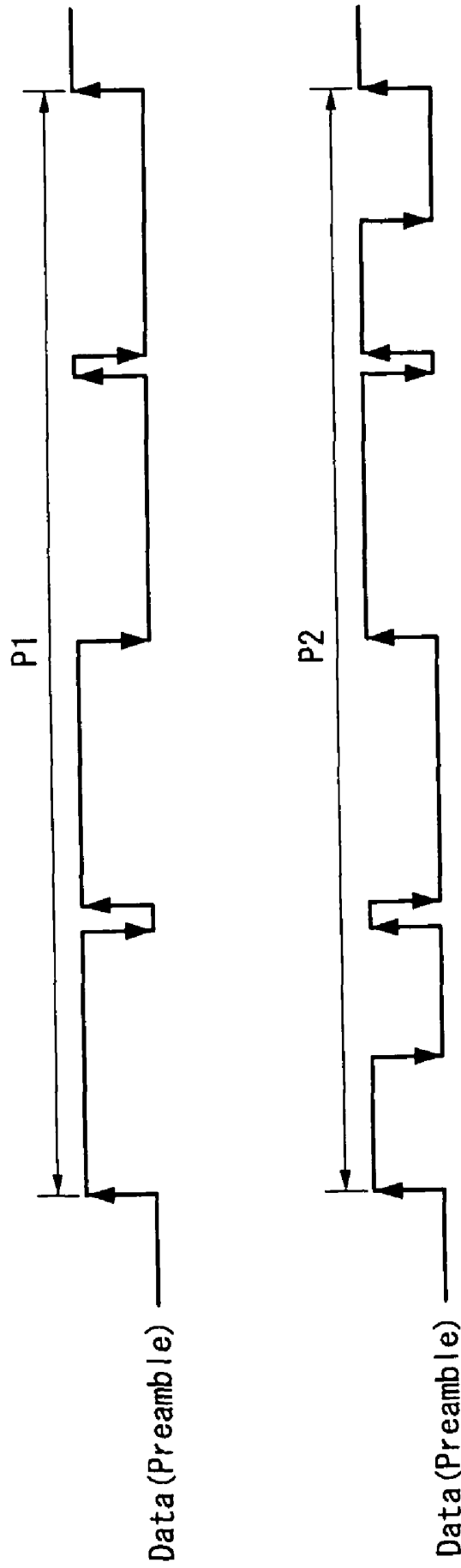
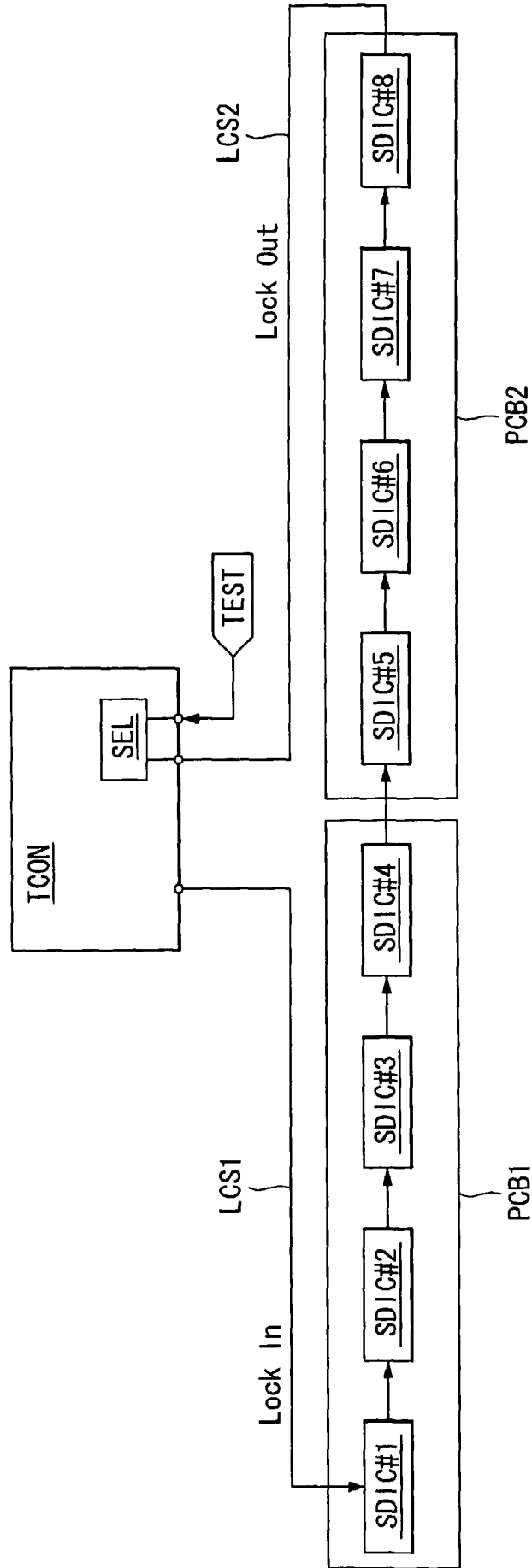

FIG. 24



## LIQUID CRYSTAL DISPLAY AND METHOD OF DRIVING THE SAME

This application claims the benefit of Korea Patent Application No. 10-2008-0127456 filed on Dec. 15, 2008, the entire contents of which are incorporated herein by reference for all purposes as if fully set forth herein.

### BACKGROUND OF THE INVENTION

#### 1. Field of the Invention

Embodiments of the inventions relate to a liquid crystal display and a method of driving the same.

#### 2. Discussion of the Related Art

Active matrix type liquid crystal displays image a moving picture using thin film transistors (TFT) as an element to switch the liquid crystal. Active matrix type liquid crystal displays have been implemented in televisions as well as display devices in portable devices, such as office equipment and computers, because of the thin profile of an active matrix type liquid crystal display. Accordingly, cathode ray tubes (CRT) are being rapidly replaced by active matrix type liquid crystal displays.

A liquid crystal display includes a plurality of source drive integrated circuits (ICs) supplying a data voltage to data lines of the liquid crystal display panel, a plurality of gate drive ICs sequentially supplying a gate pulse (i.e., a scan pulse) to gate lines of the liquid crystal display panel, and a timing controller controlling the source drive ICs and the gate drive ICs. In the liquid crystal display, digital video data is input to the timing controller through an interface.

The timing controller supplies the digital video data, a clock for sampling the digital video data, a control signal for controlling an operation of the source drive ICs, and the like to the source drive ICs through an interface such as a mini low-voltage differential signaling (LVDS) interface. The source drive ICs deserializes the digital video data serially input from the timing controller to output parallel data and then converts the parallel data into an analog data voltage using a gamma compensation voltage to supply the analog data voltage to the data lines.

The timing controller supplies necessary signals to the source drive ICs using a multi-drop manner of commonly applying the clock and the digital video data to the source drive ICs. Because the source drive ICs are cascade-connected to one another, the source drive ICs sequentially sample the digital video data and then simultaneously output data voltages corresponding to 1 line. In such a data transfer method, many lines such as R, G, and B data transfer lines, control lines for controlling outputs of the source drive ICs and an operation timing of a polarity change of the source drive ICs, and clock transfer lines are necessary between the timing controller and the source drive ICs. Because the mini LVDS interface is a manner of transferring each of the digital video data and the clock in the form of a pair of differential signals, which are out of phase with each other, at least 14 data transfer lines between the timing controller and the source drive ICs are necessary to simultaneously transfer odd data and even data. Accordingly, because many data transfer lines have to be formed on a printed circuit board (PCB) positioned between the timing controller and the source drive ICs, it is difficult to reduce the number of data transfer lines.

### SUMMARY OF THE INVENTION

Embodiments of the inventions provide a liquid crystal display and a method of driving the same, capable of reducing

the number of signal transfer lines between a timing controller and source drive integrated circuits (ICs).

In one aspect, there is a liquid crystal display comprising a timing controller, N source drive integrated circuits (ICs), where N is an integer equal to or greater than 2, N pairs of data bus lines, each of which connects the timing controller to each of the N source drive ICs in a point-to-point manner, a lock check line that connects a first source drive IC of the N source drive ICs to the timing controller and cascade-connects the N source drive ICs to one another, and a feedback lock check line that connects a last source drive IC of the N source drive ICs to the timing controller. The timing controller serially transfers a preamble signal, in which a plurality of bits having a high logic level are successively arranged and then a plurality of bits having a low logic level are successively arranged, to each of the N source drive ICs through each of the N pairs of data bus lines, transfers a lock signal indicating that a phase of an internal clock pulse output from each of the N source drive ICs is locked to the first source drive IC through the lock check line, receives a feedback signal of the lock signal from the last source drive IC through the feedback lock check line, and serially transfers at least one source control packet for controlling a data voltage output from each of the N source drive ICs to each of the N source drive ICs through each of the N pairs of data bus lines.

After the timing controller serially transfers the source control packet, the timing controller serially transfers at least one RGB data packet to each of the N source drive ICs through each of the N pairs of data bus lines.

The RGB data packet successively includes clock bits, first RGB data bits, internal data enable clock bits, and second RGB data bits in the order named.

Each of the N source drive ICs restores a first reference clock from the preamble signal to output the first reference clock and a first internal clock pulse whose a phase is locked. If the phases of the first internal clock pulses output from the N source drive ICs are locked, the last source drive IC transfers the feedback signal of the lock signal to the timing controller through the feedback lock check line, and then each of the N source drive ICs restores source control data from the source control packet. Each of the N source drive ICs restores a second reference clock from the clock bits included in the RGB data packet, samples RGB data included in the RGB data packet based on the second reference clock and a second internal clock pulse whose a phase is locked, and converts the RGB data into a positive or negative data voltage depending on the source control data to output the positive/negative data voltage.

The source control data includes a polarity control signal determining a polarity of the positive/negative data voltage that is output from each of the N source drive ICs and is supplied to data lines of a liquid crystal display panel, and a source output enable signal that controls an output timing of the positive/negative data voltage output from each of the N source drive ICs.

The source control data includes activation information of the source output enable signal, a pulse width information of the source output enable signal, and an activation information of the polarity control signal.

A pulse width of the source output enable signal is determined by a multiplication of a length of one of the source control packet and the RGB data packet by "i", where "i" is a natural number, depending on the pulse width information of the source output enable signal.

The preamble signal includes a first pulse row and a second pulse row that is generated subsequent to the first pulse row at a frequency greater than a frequency of the first pulse row.

The second pulse row includes third pulse rows each having a frequency greater than the frequency of the first pulse row and fourth pulse rows generated between the third pulse rows, the fourth pulse rows each having a frequency greater than the frequency of the third pulse rows.

The timing controller generates at least one second source control packet including at least one of PWRC1/2 option information determining an amplification ratio of an output buffer of each of the N source drive ICs, MODE option information determining an output of a charge share voltage of each of the N source drive ICs, SOE\_EN option information determining a receiving path of the source output enable signal, PACK\_EN option information determining a receiving path of the polarity control signal, CHMODE option information determining the number of output channels of the N source drive ICs, CID1/2 option information that gives a chip identification code to each of the N source drive ICs to independently control the N source drive ICs, and H\_2DOT option information determining a horizontal polarity cycle of the positive/negative data voltage output from the N source drive ICs. The timing controller transfers the second source control packet to each of the N source drive ICs through each of the N pairs of data bus lines.

After the timing controller receives at least one of the feedback signal of the lock signal and a predetermined test mode enable signal, the timing controller serially transfers the source control packet and the RGB data packet to each of the N source drive ICs through each of the N pairs of data bus lines.

The liquid crystal display further comprises a pair of control lines connecting in parallel the timing controller to the N source drive ICs. The timing controller transfers a chip identification code for individually identifying the N source drive ICs and control data controlling functions of each of the N source drive ICs to the N source drive ICs through the pair of control lines.

In another aspect, there is a method of driving a liquid crystal display including a timing controller and N source drive integrated circuits (ICs), where N is an integer equal to or greater than 2, the method comprising generating a preamble signal, in which a plurality of bits having a high logic level are successively arranged and then a plurality of bits having a low logic level are successively arranged, from the timing controller, serially transferring the preamble signal to each of the N source drive ICs through each of N pairs of data bus lines connecting the timing controller to the N source drive ICs in a point-to-point manner, generating a lock signal indicating that a phase of an internal clock pulse output from each of the N source drive ICs is locked from the timing controller, transferring the lock signal to a first source drive IC of the N source drive ICs through a lock check line that connects the first source drive IC to the timing controller and cascade-connects the N source drive ICs to one another, generating a feedback signal of the lock signal from a last source drive IC of the N source drive ICs, transferring the feedback signal of the lock signal to the timing controller through a feedback lock check line connecting the last source drive IC to the timing controller, generating at least one source control packet for controlling a data voltage output from each of the N source drive ICs from the timing controller, and serially transferring the source control packet to each of the N source drive ICs through each of the N pairs of data bus lines.

Further scope of applicability of the present invention will become apparent from the detailed description given hereinafter. However, it should be understood that the detailed description and specific examples, while indicating preferred embodiments of the invention, are given by illustration only,

since various changes and modifications within the spirit and scope of the invention will become apparent to those skilled in the art from this detailed description.

#### BRIEF DESCRIPTION OF THE DRAWINGS

The accompanying drawings, which are included to provide a further understanding of the invention and are incorporated in and constitute a part of this specification, illustrate embodiments of the invention and together with the description serve to explain the principles of the invention. In the drawings:

FIG. 1 is a block diagram illustrating a liquid crystal display according to an embodiment of the invention;

FIG. 2 illustrates lines between a timing controller and source drive integrated circuits (ICs);

FIGS. 3 and 4 are block diagrams illustrating a configuration of a source drive IC;

FIG. 5 is a block diagram illustrating a configuration of a gate drive IC;

FIG. 6 is a flow chart illustrating in stages a signal transfer process between a timing controller and source drive ICs;

FIG. 7 is a block diagram illustrating a clock separation and data sampling unit;

FIG. 8 illustrates an example of a serial communication control path and a chip identification code capable of allowing source drive ICs to perform a debugging operation;

FIG. 9 is a block diagram illustrating a phase locked loop (PLL);

FIG. 10 is a waveform diagram illustrating Phase 1 signals generated by a timing controller;

FIG. 11 is a waveform diagram illustrating Phase 2 signals generated by a timing controller;

FIGS. 12 and 13 are waveform diagrams illustrating Phase 3 signals generated by a timing controller;

FIG. 14 illustrates an example of a data mapping table of a source control packet and an RGB data packet;

FIG. 15 illustrates an example of a data mapping table of a dummy source control packet, a real source control packet, and a last dummy source control packet;

FIG. 16 illustrates a data description about each of bits of a real source control packet;

FIG. 17 is a waveform diagram illustrating a source output enable signal controlled by source output-related control data and a polarity control signal controlled by polarity-related control data in a real source control packet;

FIG. 18 illustrates a pulse width of a source output enable signal determined depending on SOE\_PRD of a real source control packet;

FIG. 19 is a waveform diagram illustrating changes in a pulse width of a source output enable signal depending on SOE\_PRD of a real source control packet;

FIG. 20 is a waveform diagram illustrating an output of a clock separation and data sampling unit;

FIGS. 21A to 21D are cross-sectional views illustrating a length conversion of an RGB data packet depending on changes in a bit rate of the RGB data packet;

FIGS. 22 and 23 are waveform diagrams illustrating Phase 1 signals according to another embodiment of the invention; and

FIG. 24 illustrates an additional configuration of a liquid crystal display according to embodiments of the invention for a test mode.

#### DETAILED DESCRIPTION OF THE EMBODIMENTS

Reference will now be made in detail embodiments of the invention examples of which are illustrated in the accompanying drawings.

As shown in FIG. 1, a liquid crystal display according to an embodiment of the invention includes a liquid crystal display panel 10, a timing controller TCON, a plurality of source drive integrated circuits (ICs) SDIC#1 to SDIC#8, and a plurality of gate drive ICs GDIC#1 to GDIC#4.

The liquid crystal display panel 10 includes an upper glass substrate, a lower glass substrate, and a liquid crystal layer between the upper and lower glass substrates. The liquid crystal display panel 10 includes  $m \times n$  liquid crystal cells Clc arranged at each of crossings of  $m$  data lines DL and  $n$  gate lines GL in a matrix format.

A pixel array including the data lines DL, the gate lines GL, thin film transistors (TFTs), a storage capacitor Cst, etc. is formed on the lower glass substrate of the liquid crystal display panel 10. Each of the liquid crystal cells Clc is driven by an electric field between a pixel electrode 1 receiving a data voltage through the TFT and a common electrode 2 receiving a common voltage Vcom. In each of the TFTs, a gate electrode is connected to the gate line GL, a source electrode is connected to the data line DL, and a drain electrode is connected to the pixel electrode 1 of the liquid crystal cell Clc. The TFT is turned on when a gate pulse is supplied through the gate line GL, and thus supplies a positive or negative analog video data voltage received through the data line DL to the pixel electrode 1 of the liquid crystal cell Clc.

A black matrix, a color filter, the common electrode 2, etc., are formed on the upper glass substrate of the liquid crystal display panel 10.

The common electrode 2 is formed on the upper glass substrate in a vertical electric drive manner, such as a twisted nematic (TN) mode and a vertical alignment (VA) mode. The common electrode 2 and the pixel electrode 1 are formed on the lower glass substrate in a horizontal electric drive manner, such as an in-plane switching (IPS) mode and a fringe field switching (FFS) mode.

Polarizing plates are respectively attached to the upper and lower glass substrates of the liquid crystal display panel 10. Alignment layers for setting a pre-tilt angle are respectively formed on the upper and lower glass substrates. A spacer is formed between the upper and lower glass substrates to keep cell gaps of the liquid crystal cells Clc constant.

The liquid crystal display according to the embodiment of the invention may be embodied in any liquid crystal mode as well as the TN, VA, IPS, and FFS modes. Further, the liquid crystal display according to the embodiment of the invention may be implemented as any type liquid crystal display including a backlit liquid crystal display, a transfective liquid crystal display, and a reflective liquid crystal display.

The timing controller TCON receives an external timing signal such as, vertical and horizontal sync signals Vsync and Hsync, an external data enable signal DE, and a dot clock CLK through an interface, such as a low voltage differential signaling (LVDS) interface and a transition minimized differential signaling (TMDS) interface to generate timing control signals for controlling operation timings of the source drive ICs SDIC#1 to SDIC#8 and operation timings of the gate drive ICs GDIC#1 to GDIC#4. The timing control signals include a gate timing control signal for controlling the operation timings of the gate drive ICs GDIC#1 to GDIC#4 and a source timing control signal for controlling the operation timings of the source drive ICs SDIC#1 to SDIC#8.

The timing controller TCON is connected to the source drive ICs SDIC#1 to SDIC#8 in a point-to-point manner. The timing controller TCON transfers a preamble signal for initializing the source drive ICs SDIC#1 to SDIC#8, a source control data including the source timing control signal, a

clock, RGB digital video data, etc. to each of the source drive ICs SDIC#1 to SDIC#8 through each of a plurality of pairs of data bus lines.

The gate timing control signal includes a gate start pulse GSP, a gate shift clock GSC, a gate output enable signal GOE, and the like. The gate start pulse GSP is applied to the first gate drive IC GDIC#1 to thereby indicate scan start time of a scan operation so that the first gate drive IC GDIC#1 generates a first gate pulse. The gate shift clock GSC is a clock for shifting the gate start pulse GSP. A shift register of each of the gate drive ICs GDIC#1 to GDIC#4 shifts the gate start pulse GSP at a rising edge of the gate shift clock GSC. The second to fourth gate drive ICs GDIC#2 to GDIC#4 receive a carry signal of the first gate drive IC GDIC#1 as a gate start pulse to start operating. The gate output enable signal GOE controls output timings of the gate drive ICs GDIC#1 to GDIC#4. The gate drive ICs GDIC#1 to GDIC#4 output a gate pulse in a low logic level state of the gate output enable signal GOE, i.e., during a period of time ranging from immediately after a falling edge of a current pulse to immediately before a rising edge of a next pulse. 1 cycle of the gate output enable signal GOE is about 1 horizontal period.

The source timing control signal is transferred to the source drive ICs SDIC#1 to SDIC#8 through the pair of data bus lines for a predetermined time interval between a transfer time of the preamble signal and a transfer time of the RGB digital video data. The source timing control signal includes polarity-related control data, source output-related control data, etc. The polarity-related control data includes control information for controlling a polarity control signal POL of pulse form generated inside the source drive ICs SDIC#1 to SDIC#8. A digital-to-analog convertor (DAC) of each of the source drive ICs SDIC#1 to SDIC#8 converts the RGB digital video data into an positive or negative analog video data voltage in response to the polarity control signal POL. The source output-related control data includes control information for controlling a source output enable signal SOE of pulse form generated inside the source drive ICs SDIC#1 to SDIC#8. The source output enable signal SOE controls an output timing of the positive/negative analog video data voltage from the source drive ICs SDIC#1 to SDIC#8.

Each of the gate drive ICs GDIC#1 to GDIC#4 sequentially supplies the gate pulse to the gate lines GL in response to the gate timing control signal.

Each of the source drive ICs SDIC#1 to SDIC#8 locks a frequency and a phase of an internal clock pulse output from a clock separation and data sampling unit embedded inside each of the source drive ICs SDIC#1 to SDIC#8. The result depends on the preamble signal transferred from the timing controller TCON through the pair of data bus lines. Then, each of the source drive ICs SDIC#1 to SDIC#8 restores a clock from a source control packet input as a digital bit stream through the pair of data bus lines to generate a serial clock. Subsequently, each of the source drive ICs SDIC#L to SDIC#8 samples the polarity-related control data and the source output-related control data. Each of the source drive ICs SDIC#1 to SDIC#8 outputs the polarity control signal POL and the source output enable signal SOE using the polarity-related control data and the source output-related control data.

After each of the source drive ICs SDIC#1 to SDIC#8 restores a clock from a source control packet input as a digital bit stream through the pair of data bus lines to restore the polarity control signal POL and the source output enable signal SOE, each of the source drive ICs SDIC#1 to SDIC#8 restores a clock from an RGB data packet input as a digital bit stream through the pair of data bus lines to generate a serial

clock for data sampling. Further, each of the source drive ICs SDIC#1 to SDIC#8 samples RGB digital video data serially input depending on the serial clock. Each of the source drive ICs SDIC#1 to SDIC#8 deserializes the sequentially sampled RGB digital video data to output RGB parallel data. Then, each of the source drive ICs SDIC#1 to SDIC#8 converts the RGB parallel data into the positive/negative analog video data voltage in response to the polarity control signal POL to supply the positive/negative analog video data voltage to the data lines DL in response to the source output enable signal SOE.

FIG. 2 illustrates lines between the timing controller TCON and the source drive ICs SDIC#1 to SDIC#8.

As shown in FIG. 2, a plurality of pairs of data bus lines DATA&CLK, first and second pairs of control lines SCL/SDA1 and SCL/SDA2, lock check lines LCS1 and LCS2, etc. are formed between the timing controller TCON and the source drive ICs SDIC#1 to SDIC#8.

The timing controller TCON sequentially transfers the preamble signal, the source control packet, and the RGB data packet to each of the source drive ICs SDIC#1 to SDIC#8 through each of the pairs of data bus lines DATA&CLK. The source control packet is a bit stream including clock bits, polarity-related control data bits, source output-related control data bits, etc. The RGB data packet is a bit stream including clock bits, internal data enable clock bits, RGB data bits, etc. Each of the pairs of data bus lines DATA&CLK connects in series the timing controller TCON to each of the source drive ICs SDIC#1 to SDIC#8. Namely, the timing controller TCON is connected to the source drive ICs SDIC#1 to SDIC#8 in the point-to-point manner. Each of the source drive ICs SDIC#1 to SDIC#8 restores clocks input through the pair of data bus lines DATA&CLK. Accordingly, lines for transferring a clock carry and the RGB video data are not necessary between the adjacent source drive ICs SDIC#1 to SDIC#8.

The timing controller TCON transfers a chip identification code CID of each of the source drive ICs SDIC#1 to SDIC#8 and chip individual control data for controlling functions of each of the source drive ICs SDIC#1 to SDIC#8 to each of the source drive ICs SDIC#1 to SDIC#8 through the pairs of control lines SCL/SDA1 and SCL/SDA2. The pairs of control lines SCL/SDA1 and SCL/SDA2 are commonly connected between the timing controller TCON and the source drive ICs SDIC#1 to SDIC#8. More specifically, as shown in FIG. 8, if the source drive ICs SDIC#1 to SDIC#8 are divided into two groups and the two groups are respectively connected to printed circuit boards (PCBs) PCB1 and PCB2, the first pair of control lines SCL/SDA1 on the left connect in parallel the timing controller TCON to the first to fourth source drive ICs SDIC#1 to SDIC#4, and the second pair of control lines SCL/SDA2 on the right connect in parallel the timing controller TCON to the fifth to eighth source drive ICs SDIC#5 to SDIC#8.

The timing controller TCON supplies a lock signal LOCK, that confirms whether or not a phase and a frequency of the internal clock pulse output from the clock separation and data sampling unit of each of the source drive ICs SDIC#1 to SDIC#8 is stably locked, to the first source drive IC SDIC#1 through a lock check line LCS1. The source drive ICs SDIC#1 to SDIC#8 are cascade-connected to one another through the lock check line LCS1. If a frequency and a phase of an internal clock pulse output from the first source drive IC SDIC#1 are locked, the first source drive IC SDIC#1 transfers the lock signal LOCK of a high logic level to the second source drive IC SDIC#2. Next, after a frequency and a phase of an internal clock pulse output from the second source drive

IC SDIC#2 are locked, the second source drive IC SDIC#2 transfers the lock signal LOCK of a high logic level to the third source drive IC SDIC#3. The above-described locking operation is sequentially performed, and finally, after a frequency and a phase of an internal clock pulse output from the last source drive IC SDIC# are locked, the last source drive IC SDIC#8 feedback-inputs the lock signal LOCK of a high logic level to the timing controller TCON through a feedback lock check line LCS2. Only after the timing controller TCON receives a feedback signal of the lock signal LOCK, the timing controller TCON transfers the RGB data packets to the source drive ICs SDIC#1 to SDIC#8.

FIG. 3 is a block diagram illustrating a configuration of the source drive ICs SDIC#1 to SDIC#8.

As shown in FIG. 3, each of the source drive ICs SDIC#1 to SDIC#8 supplies the positive/negative analog video data voltage to the k data lines D1 to Dk (where k is a positive integer less than m). Each of the source drive ICs SDIC#1 to SDIC#8 includes a clock separation and data sampling unit 21, a digital-to-analog converter (DAC) 22, an output circuit 23, etc.

In Phase 1, the clock separation and data sampling unit 21 locks the phase and the frequency of the internal clock pulse depending on the preamble signal input at a low frequency through the pair of data bus lines DATA&CLK. Subsequently, in Phase 2, the clock separation and data sampling unit 21 restores a reference clock from the source control packet input as a bit stream through the pair of data bus lines DATA&CLK and separates the polarity-related control data from the reference clock to thereby restore the polarity control signal POL based on the polarity-related control data. Further, the clock separation and data sampling unit 21 separates the source output-related control data from the source control packet to restore the source output enable signal SOE based on the source output-related control data.

Subsequently, in Phase 3, the clock separation and data sampling unit 21 separates a clock from the RGB data packet input through the pair of data bus lines DATA&CLK to restore a reference clock. Further, the clock separation and data sampling unit 21 generates serial clock signals for sampling each of the RGB digital video data bits depending on the reference clock. For this, the clock separation and data sampling unit 21 includes a phase locked circuit capable of outputting internal clock pulses having a stable phase and a stable frequency. Examples of the phase locked circuit include a phase locked loop (PLL) and a delay locked loop (DLL). In the embodiment, an example of using a PLL circuit as the phase locked circuit will be described later. In the embodiment, the clock separation and data sampling unit 21 may include the DLL as well as the PLL.

FIGS. 7 to 9 illustrate an example of embodying the clock separation and data sampling unit 21 using the PLL. However, the clock separation and data sampling unit 21 may be embodied using the DLL.

The clock separation and data sampling unit 21 samples and latches each of the RGB data bits serially input through the pair of data bus lines DATA&CLK depending on the serial clock and then simultaneously outputs the latched RGB data. Namely, the clock separation and data sampling unit 21 converts serial data into RGB parallel data.

The DAC 22 converts the RGB digital video data from the clock separation and data sampling unit 21 into a positive gamma compensation voltage GH or a negative gamma compensation voltage GL in response to the polarity control signal POL and then converts the positive gamma compensation voltage GH or the negative gamma compensation voltage GL into a positive or negative analog video data voltage. For the

above-described operation, as shown in FIG. 4, the DAC 22 includes a P-decoder (PDEC) 41 receiving the positive gamma compensation voltage GH, an N-decoder (NDEC) 42 receiving the negative gamma compensation voltage GL, and a multiplexer 43 selecting an output of the P-decoder 41 and an output of the N-decoder 42 in response to the polarity control signal POL. The P-decoder 41 decodes RGB digital video data input from the clock separation and data sampling unit 21 to output the positive gamma compensation voltage GH corresponding to a gray level of the RGB digital video data. The N-decoder 42 decodes RGB digital video data input from the clock separation and data sampling unit 21 to output the negative gamma compensation voltage GL corresponding to a gray level of the RGB digital video data. The multiplexer 43 alternately selects the positive gamma compensation voltage GH and the negative gamma compensation voltage GL in response to the polarity control signal POL and outputs the positive or negative analog video data voltage as the selected positive or negative gamma compensation voltage GH or GL.

The output circuit 23 supplies a charge share voltage or the common voltage Vcom to the data lines D1 to Dk through an output buffer during a high logic level period of the source output enable signal SOE. The output circuit 23 supplies the positive/negative analog video data voltage to the data lines D1 to Dk through the output buffer during a low logic level period of the source output enable signal SOE. The charge share voltage is generated when the data line receiving the positive analog video data voltage and the data line receiving the negative analog video data voltage are short-circuited. The charge share voltage has an average voltage level between the positive analog video data voltage and the negative analog video data voltage.

FIG. 5 is a block diagram illustrating a configuration of the gate drive ICs GDIC#1 to GDIC#4.

As shown in FIG. 5, each of the gate drive ICs GDIC#1 to GDIC#4 includes a shift register 50, a level shifter 52, a plurality of AND gates 51 connected between the shift register 50 and the level shifter 52, and an inverter 53 for inverting the gate output enable signal GOE.

The shift register 50 includes a plurality of cascade connected D flip-flops and sequentially shifts the gate start pulse GSP in response to the gate shift clock GSC using the cascade connected D flip-flops. Each of the AND gates 51 performs an AND operation on an output signal of the shift register 50 and an inversion signal of the gate output enable signal GOE to obtain an output. The inverter 53 inverts the gate output enable signal GOE and supplies the inversion signal of the gate output enable signal GOE to the AND gates 51. Accordingly, each of the gate drive ICs GDIC#1 to GDIC#4 outputs the gate pulse when the gate output enable signal GOE is in a low logic level state.

The level shifter 52 shifts a swing width of an output voltage of the AND gate 51 to a swing width suitable to drive the TFTs in the pixel array of the liquid crystal display panel 10. An output signal of the level shifter 52 is sequentially supplied to the gate lines G1 to Gk.

The shift register 50 together with the TFTs of the pixel array may be directly formed on the glass substrate of the liquid crystal display panel 10. In this case, the level shifter 52 may be formed on not the glass substrate of the liquid crystal display panel 10 but a control board or a source PCB together with the timing controller TCON, a gamma voltage generating circuit, etc.

FIG. 6 is a flow chart illustrating in stages a signal transfer process between the timing controller TCON and the source drive ICs SDIC#1 to SDIC#8.

As shown in FIG. 6, if a power is applied to the liquid crystal display, the timing controller TCON supplies Phase 1 signals to each of the source drive ICs SDIC#1 to SDIC#8 through each of the pairs of data bus lines DATA&CLK in steps S1 and S2. The Phase 1 signals include the preamble signal of a low frequency and a lock signal supplied to the first source drive IC SDIC#1.

The clock separation and data sampling unit 21 of the first source drive IC SDIC#1 restores the preamble signal to a PLL reference clock and transfers a lock signal of a high logic level to the second source drive IC SDIC#2 when a phase of the PLL reference clock and a phase of an internal clock pulse output from the PLL of the first source drive IC SDIC#1 are locked, in steps S3 to S5. Subsequently, when internal clock pulses output from the clock separation and data sampling units 21 of the second to eighth source drive ICs SDIC#2 to SDIC#8 are sequentially locked stably, the eighth source drive IC SDIC#8 feedback inputs a lock signal of a high logic level to the timing controller TCON in steps S6 and S7.

If the timing controller TCON receives the lock signal of the high logic level from the eighth source drive IC SDIC#8, the timing controller TCON decides that a phase and a frequency of the internal clock pulse output from the clock separation and data sampling unit 21 of each of all the source drive ICs SDIC#1 to SDIC#8 are stably locked. Thus, the timing controller TCON supplies Phase 2 signals to the source drive ICs SDIC#1 to SDIC#8 through the pairs of data bus lines DATA&CLK in the point-to-point manner in step S8. The Phase 2 signals include a plurality of source control packets including polarity-related control data bits and source output-related control data bits.

Following the Phase 2 signals, the timing controller TCON supplies Phase 3 signals to the source drive ICs SDIC#1 to SDIC#8 in the point-to-point manner in step S10. The Phase 3 signals include a plurality of RGB data packets to which the liquid crystal cells on 1 line of the liquid crystal display panel 10 will be charged during 1 horizontal period.

The PLL output of the clock separation and data sampling unit 21 of each of the source drive ICs SDIC#1 to SDIC#8 may be unlocked during an output transfer process of the Phase 2 signals or the Phase 3 signals. Namely, the phase and the frequency of the internal clock pulse output from the PLL of the clock separation and data sampling unit 21 may be unlocked. More specifically, when the timing controller TCON receives the feedback signal of the lock signal inverted at a low logic level, the timing controller TCON decides that the internal clock pulses output from the PLL of the clock separation and data sampling unit 21 are unlocked, in step S9 and S11. Thus, the timing controller TCON transfers the Phase 1 signals to the source drive ICs SDIC#1 to SDIC#8. Subsequently, after, the phase and the frequency of the internal clock pulse output from the PLL of each of the source drive ICs SDIC#1 to SDIC#8 are locked, the timing controller TCON again starts performing the output transfer process of the Phase 2 signals and the Phase 3 signals.

FIG. 7 is a block diagram illustrating the clock separation and data sampling unit 21 of each of the source drive ICs SDIC#1 to SDIC#8.

As shown in FIG. 7, the clock separation and data sampling unit 21 includes an on-die terminator (ODT) 61, an analog delay replica (ADR) 62, a clock separator 63, a PLL 64, a PLL lock detector 65, a tunable analog delay 66, a deserializer 67, a digital filter 68, a phase detector 69, a lock detector 70, an I<sup>2</sup>C controller 71, a power-on reset (POR) 72, an AND gate 73, and an SOE&POL restoring unit 74.

The ODT 61 includes a termination resistor embedded inside the ODT 61 to improve signal integrity by removing a

noise mixed in the preamble signal, the source control packet, and the RGB data packet received through the pairs of data bus lines DATA&CLK. Further, the ODT 61 includes a receiving buffer and an equalizer embedded inside the ODT 61 to amplify an input differential signal and to convert the amplified differential signal into digital data. The ADR 62 delays the RGB data and the clock received from the ODT 61 by a delay value of the tunable analog delay 66 to allow a delay value of a clock path to be equal to a delay value of a data path.

The clock separator 63 separates clock bits from the source control packet and the RGB digital data packet restored by the ODT 61 to restore the clock bits to a reference clock of the PLL 64. The clock bits include clock bits, dummy clock bits, internal data enable clock bits, etc. The PLL 64 generates clocks for sampling bits of the source control packet and bits of the RGB data packet. If the RGB data packet includes 10-bit RGB data and 4-bit clocks are assigned between the 10-bit RGB data, the PLL 64 generates 34 internal clock pulses per 1 RGB data packet. The PLL lock detector 65 checks a phase and a frequency of each of the internal clock pulses output from the PLL 64 in conformity with a predetermined data rate to detect whether or not the internal clock pulses are locked.

The tunable analog delay 66 compensates for a slight phase difference between the RGB data received from the ODT 61 and restored clocks feedback-input via the phase detector 69 and the digital filter 68, so that data can be sampled in the center of the clock. The deserializer 67 includes a plurality of flip-flops embedded inside the deserializer 67 to sample and latch bits of the RGB digital video data serially input in response to internal serial clock pulses serially output from the PLL 64. Then, the deserializer 67 simultaneously outputs the latched RGB digital video to thereby output RGB parallel data.

The digital filter 68 and the phase detector 69 receive the sampled RGB digital video data and determine a delay value of the tunable analog delay 66. The lock detector 70 compares the RGB parallel data restored by the deserializer 67 with an output PLL\_LOCK of the PLL lock detector 65 to check an error amount of data enable clocks of the RGB parallel data. If the error amount is equal to or greater than a predetermined value, a physical interface (PHY) circuit entirely operates again by unlocking the internal clock pulses output from the PLL 64. The lock detector 70 generates an output of a low logic level when the internal clock pulses output from the PLL 64 are unlocked. On the other hand, the lock detector 70 generates an output of a high logic level when the internal clock pulses output from the PLL 64 are locked. The AND gate 73 performs an AND operation on a lock signal "Lock In" received from the timing controller TCON or a lock signal "Lock In" transferred by the source drive ICs SDIC#1 to SDIC#7 in previous stage and an output of the lock detector 70. Then, the AND gate 73 outputs a lock signal "Lock Out" of a high logic level when the lock signal "Lock In" and the output of the lock detector 70 are in a high logic level state. The lock signal "Lock Out" of the high logic level is transferred to the source drive ICs SDIC#2 to SDIC#8 in next stage, and the last source drive IC SDIC#8 inputs the lock signal "Lock Out" to the timing controller TCON.

The POR 72 generates a reset signal RESETB for initializing the clock separation and data sampling unit 21 depending on a previously set power sequence and generates a clock of about 50 MHz to supply the clock to digital circuits including the above circuits.

The I<sup>2</sup>C controller 71 controls an operation of each of the above circuit blocks using the chip identification code CID

input as serial data through the pair of control lines SCL/SDA and the chip individual control data. The chip identification codes CID each having a different logic level are respectively given to the source drive ICs SDIC#1 to SDIC#8 as shown in FIG. 8, so that the source drive ICs SDIC#1 to SDIC#8 can be individually controlled. The I<sup>2</sup>C controller 71 may perform PLL power down, buffer power down of the ODT 61, EQ On/Off operation of the ODT 61, a control of a charge bump current of the PLL 64, a control of VCO range manual selection of the PLL 64, PLL lock signal push through I<sup>2</sup>C communication, an adjustment of an analog delay control value, disable of the lock detector 70, a change in a coefficient of the digital filter 68, a change function in a coefficient of the digital filter 68, physical interface (PHY)\_RESETB signal push through I<sup>2</sup>C, an operation of substituting the lock signal of the previous source drive ICs SDIC#1 to SDIC#7 with a reset signal of the current source drive ICs SDIC#1 to SDIC#8, setting of a vertical resolution of an input image, a storage of a history about data enable clock transition for analyzing a generation cause of the physical interface (PHY)\_RESETB signal, etc depending on the chip individual control data input from the timing controller TCON through serial data bus SDA of the pair of control lines SCL/SDA.

The SOE&POL restoring unit 74 samples the polarity-related control data of the source control packet from the ODT 61 in response to the internal clock pulses output from the PLL 64 to generate the polarity control signal POL of a high logic level (or a low logic level). Then, the SOE&POL restoring unit 74 inverts a logic level of the polarity control signal POL every *i* horizontal periods (where, "*i*" is a natural number). The SOE&POL restoring unit 74 samples the source output-related control data of the source control packet from the ODT 61 in response to the internal clock pulses output from the PLL 64 to generate the source output enable signal SOE determining output timing of the source drive ICs SDIC#1 to SDIC#8 based on the source output-related control data. The SOE&POL restoring unit 74 detects information about a pulse width from the source output-related control data and counts a reference clock REF(SCLK) restored by the PLL 64 to thereby determine a pulse width of the source output enable signal SOE.

FIG. 9 is a block diagram illustrating the PLL 64.

As shown in FIG. 9, the PLL 64 includes a phase comparator 92, a charge pump 93, a loop filter 94, a pulse-to-voltage converter 95, a voltage controlled oscillator (VCO) 96, and a digital controller 97.

The phase comparator 92 compares a phase of a reference clock REF\_clk received from the clock separator 63 with a phase of a feedback edge clock FB\_clk received from a clock separator replica (CSR) 91. The phase comparator 92 has a pulse width corresponding to a phase difference between the reference clock REF\_clk and the feedback edge clock FB\_clk as a comparison result. When the phase of the reference clock REF\_clk is earlier than the phase of the feedback edge clock FB\_clk, the phase comparator 92 outputs a positive pulse. On the other hand, when the phase of the reference clock REF\_clk is later than the phase of the feedback edge clock FB\_clk, the phase comparator 92 outputs a negative pulse.

The charge pump 93 controls an amount of charges supplied to the loop filter 94 depending on a width and a polarity of an output pulse of the phase comparator 92. The loop filter 94 accumulates or discharges the charges depending on the amount of charges controlled by the charge pump 93 and removes a high frequency noise including a harmonic component in a clock input to the pulse-to-voltage converter 95.

The pulse-to-voltage converter 95 converts a pulse received from the loop filter 94 into a control voltage of the

VCO 96 and controls a level of the control voltage of the VCO 96 depending on a width and a polarity of the pulse received from the loop filter 94. When a bit stream of 1 RGB data packet includes 10-bit RGB data and 4 clock bits, the VCO 96 generates 34 edge clocks and 34 center clocks per the 1 RGB data packet. Further, the VCO 96 controls a phase delay amount of clocks depending on the control voltage from the pulse-to-voltage converter 95 and depending on control data from the digital controller 97.

A first edge clock EG[0] output from the VCO 96 is a feedback edge clock and is input to the clock separator replica 91. The feedback edge clock EG[0] has a frequency corresponding to  $\frac{1}{34}$  of an output frequency of the VCO 96. The digital controller 97 receives the reference clock REF\_clk from the clock separator 63 and the feedback edge clock FB\_clk from the clock separator replica 91 and compares a phase of the reference clock REF\_clk with a phase of the feedback edge clock FB\_clk. Further, the digital controller 97 compares a phase difference obtained as a comparison result with a phase of a 50-MHz clock signal clk\_osc from the POR 72. The digital controller 97 controls an output delay amount of the VCO 96 depending on a comparison result of a phase difference to select an oscillation area of the VCO 96.

FIG. 10 is a waveform diagram illustrating signals generated by the timing controller TCON in Phase 1.

As shown in FIG. 10, in Phase 1, the timing controller TCON generates a lock signal and a preamble signal of a low frequency. In the preamble signal of the low frequency, a plurality of bits having a high logic level are successively arranged, and then a plurality of bits having a low logic level are successively arranged. A frequency of the preamble signal corresponds to  $\frac{1}{34}$  of a frequency of the internal clock pulse output from the PLL 64 of the clock separation and data sampling unit 21 when a bit stream of 1 RGB data packet includes 10-bit RGB data and 4 clock bits. The clock separator 63 of the clock separation and data sampling unit 21 transitions the reference clock REF\_clk to a high logic level in synchronization with bits of the preamble signal of a high logic level and transitions the reference clock REF\_clk to a low logic level in synchronization with bits of the preamble signal of a low logic level.

The clock separation and data sampling unit 21 of each of the source drive ICs SDIC#1 to SDIC#8 repeatedly performs an operation of comparing the phase of the reference clock REF\_clk generated depending on the preamble signal with the phase of the feedback edge clock FB\_clk and locking the internal clock pulses. If the internal clock pulses are stably locked, the lock signal is transferred to the source drive ICs SDIC#1 to SDIC#8 in next stage.

In an initial power-on phase of the liquid crystal display, the timing controller TCON receives the lock signal from the last source drive IC SDIS#8 to confirm that a phase and a frequency of the internal clock pulses serially output from the clock separation and data sampling unit 21 are locked. Then, the timing controller TCON outputs the Phase 2 signals during a blanking period of the vertical sync signal Vsync. If the internal clock pulses of the clock separation and data sampling unit 21 are unlocked during a display of video data on the liquid crystal display, the timing controller TCON receives the lock signal from the last source drive IC SDIS#8 to confirm that a phase and a frequency of the internal clock pulses serially output from the clock separation and data sampling unit 21 are locked. Then, the timing controller TCON outputs the Phase 2 signals during a first blanking period of the vertical sync signal Vsync and the horizontal sync signal Hsync.

FIG. 11 is a waveform diagram illustrating signals generated by the timing controller TCON in Phase 2.

As shown in FIG. 11, in Phase 2, the timing controller TCON successively transfers a plurality of front dummy source control packets Cf, at least one real source control packet Cr, a plurality of back dummy source control packets Cb and Cl in the order named to each of the source drive ICs SDIC#1 to SDIC#8 through the pair of data bus lines DATA&CLK during a blanking period, in which there is no data, in 1 cycle (i.e., 1 horizontal period) of the horizontal sync signal Hsync.

The plurality of front dummy source control packets Cf are successively transferred to the source drive ICs SDIC#1 to SDIC#8 prior to the real source control packet Cr, so that the clock separation and data sampling unit 21 stably receives the real source control packet Cr. The real source control packet Cr includes polarity-related control data bits and source output-related control data bits for controlling a polarity inversion operation and a data output of the source drive ICs SDIC#1 to SDIC#8. The plurality of back dummy source control packets Cb and Cl subsequent to the real source control packet Cr are successively transferred to the source drive ICs SDIC#1 to SDIC#8, so that the clock separation and data sampling unit 21 performs a receiving confirming operation of the real source control packet Cr and stably receives the Phase 3 signals. A bit value indicating that the Phase 3 signals are transferred subsequent to a last dummy source control packet Cl of the back dummy source control packets Cb and Cl is assigned to the last dummy source control packet Cl.

The front dummy source control packets Cf, the real source control packet Cr, and the back dummy source control packets Cb and Cl may be distinguished from one another by predetermined bit values as shown in a data mapping table of FIG. 15. Accordingly, the SOE&POL restoring unit 74 of the clock separation and data sampling unit 21 distinguishes the source control packets Cf, Cr, Cb, and Cl from one another by predetermined bit values. Thus, the SOE&POL restoring unit 74 may discriminate between the polarity-related control data and the source output-related control data of the real source control packet Cr.

The clock separation and data sampling unit 21 of each of the source drive ICs SDIC#1 to SDIC#8 separates clocks from the source control packets Cf, Cr, Cb, and Cl to restore a reference clock and compares a phase of the reference clock with a phase of internal clock pulses of a high frequency to serially output the internal clock pulses for sampling the polarity-related control data bits and the source output-related control data bits. Further, the clock separation and data sampling unit 21 generates the polarity control signal POL depending on the sampled polarity-related control data and generates the source output enable signal SOE depending on the sampled source output-related control data.

As shown in FIG. 11, an RGB data packet is transferred subsequent to the plurality of source control packets Cf, Cr, Cb, and Cl during 1 horizontal period, and then a plurality of source control packets may be additionally transferred subsequent to the RGB data packet. The source control packets additionally transferred subsequent to the RGB data packet may include at least one real source control packet and a plurality of dummy source control packets, and the real source control packet may affect an RGB data packet of a next horizontal period.

FIGS. 12 and 13 are waveform diagrams illustrating signals generated by the timing controller TCON in Phase 3.

As shown in FIGS. 12 and 13, following the Phase 2 signals, the timing controller TCON transfers Phase 3 signals (i.e., a plurality of RGB data packets to be displayed on 1 line

of the liquid crystal display) to each of the source drive ICs SDIC#1 to SDIC#8 through the pair of data bus lines DATA&CLK during 1 horizontal period.

More specifically, the clock separation and data sampling unit 21 separates a clock CLK and an internal data enable clock DE from the RGB data packet to restore a reference clock. Then, the clock separation and data sampling unit 21 compares a phase of the reference clock with a phase of internal clock pulses of a high frequency to serially output the internal clock pulses for sampling each of bits of the RGB digital video data. If a bit stream of 1 RGB data packet includes 10-bit RGB data and 4 clock bits, bits of a dummy clock DUM of a low logic level, bits of a clock CLK of a high logic level, bits R1 to R10, bits G1 to G5, bits of a dummy data enable clock DE DUM of a low logic level, bits of an internal data enable clock DE of a high logic level, bits G6 to G10, and bits B1 to B10 are successively assigned to the 1 RGB data packet in the order named. The clock separation and data sampling unit 21 detects the clock CLK and the internal data enable clock DE and thus may decide data serially input subsequent to the clock CLK and the internal data enable clock DE as the RGB digital video data. Further, the clock separation and data sampling unit 21 samples the RGB digital video data depending on sampling clock.

To indicate a state where the RGB digital video data is not included, the clock separation and data sampling unit 21 sets bit values of the dummy data enable clock DE DUM and the data enable clock DE in each of the Phase 1 signal and the Phase 2 signal at different bit values from bit values of the dummy data enable clock DE DUM and the data enable clock DE in the Phase 3 signal.

The clock separator 63 of the clock separation and data sampling unit 21 generates a reference clock REF\_clk, with a rising edge synchronized with the clock CLK and the internal data enable clock DE. Because the reference clock REF\_clk is again transitioned in response to the internal data enable clock DE, a frequency of the reference clock REF\_clk in Phase 3 may be two times a frequency of the reference clock REF restored in Phase 1 and Phase 2. As above, if the frequency of the reference clock REF\_clk of the clock separation and data sampling unit 21 increases, an output of the PLL 64 can be further stabilized because the number of stages inside the VCO of the PLL 64 may decrease. More specifically, if the reference clock REF\_clk of the PLL 64 transitions in the middle of the RGB data packet in response to the internal data enable clock DE to increase the frequency of the reference clock REF\_clk of the PLL 64 by two times, the number of stages inside the VCO of the PLL 64 may decrease to 1/2. If the internal data enable clock DE does not use the reference clock REF\_clk as a transition clock, 34 VCO stages are necessary. On the other hand, if the internal data enable clock DE uses the reference clock REF\_clk as a transition clock, 17 VCO stages are necessary. If the number of VCO stages in the PLL 64 increases, an effect resulting from changes in a process, a voltage, and a temperature PVT is represented by a multiplication of an increase width in the number of VCO stages. Therefore, the locking of the PLL 64 may be released because of such an external change. Accordingly, the embodiment of the invention uses the internal data enable clock DE in addition to the clock CLK as the transition clock and thus can increase the frequency of the reference clock REF\_clk of the PLL. Hence, locking reliability of the PLL 64 can be improved.

The RGB data packet and the source control packets Cf, Cr, Cb, and Cl may be distinguished from each other by setting predetermined bit values differently from each other. FIG. 14 illustrates a data mapping table of the source control packets

Cf, Cr, Cb, and Cl generated in Phase 2 and the RGB data packet generated in Phase 3. However, the data mapping table according to the embodiment of the invention is not limited to the data mapping table shown in FIG. 14 and may be variously modified based on the data mapping table shown in FIG. 14.

As shown in FIG. 14, if each of R data, G data, and B data is 10-bit data, the RGB data packet includes a total of 34-bit. More specifically, the RGB data packet includes 1-bit clock, 10-bit R data [0:9], 5-bit G data [0:4], 1-bit dummy enable clock DE DUM, 1-bit data enable clock DE, 5-bit G data [5:9], and 10-bit B data [0:9]. The source control packets Cf, Cr, and Cb have a data length (i.e., 34-bit) equal to a data length of the RGB data packet. More specifically, each of the source control packets Cf, Cr, and Cb includes 1-bit clock, 15-bit first control data replacing R data [0:9] and G data [0:4], 1-bit dummy data enable clock DE DUM, 1-bit data enable clock DE, and 15-bit second control data replacing G data [5:9] and B data [0:9]. The RGB data packet and the source control packets Cf, Cr, and Cb may be distinguished from each other by setting a bit value of the dummy data enable clock DE DUM and a bit value of the data enable clock DE differently from each other.

The dummy source control packets Cf, Cb, and Cl and the real source control packet Cr may be distinguished from each other by predetermined bits determined by the first control data and the second control data of FIG. 14. FIG. 15 illustrates an example of a data mapping table of the source control packets. However, the data mapping table according to the embodiment of the invention is not limited to the data mapping table shown in FIG. 15 and may be variously modified based on the data mapping table shown in FIG. 15.

FIG. 15 illustrates a data mapping table of the source control packets Cf, Cr, Cb, and Cl.

As shown in FIG. 15, in the dummy source control packets Cf, Cb, and Cl, a high logic level H, a low logic level L, a low logic level L, and a low logic level L are respectively assigned to 4 bits C0 to C3. On the other hand, in the real source control packet Cr, a high logic level H, a high logic level H, a high logic level H, and a low logic level L are respectively assigned to 4 bits C0 to C3. Accordingly, the dummy source control packets Cf, Cb, and Cl and the real source control packet Cr may be distinguished by bit values of C1 and C2.

The last dummy source control packet Cl indicating a transfer of the RGB data packet may be distinguished from the dummy source control packets Cf and Cb by 2 bits C16 and C17.

FIG. 16 illustrates a data description about each of bits of the real source control packet Cr.

As shown in FIG. 16, the source output-related control data includes 'SOE' of bit C2 of the real source control packet Cr and SOE\_PRD[3:0] between bits C4 and C11, and the polarity-related control data includes 'POL' of bit C14 of the real source control packet Cr.

As shown in FIG. 17, if the SOE&POL restoring unit 74 detects bit C2 of the real source control packet Cr, the SOE&POL restoring unit 74 generates a pulse of the source output enable signal SOE at a previously determined rising time. Further, the SOE&POL restoring unit 74 detects SOE\_PRD[3:0] in bits C5, C7, C9, and C11 of the real source control packet Cr to add the restored reference clock REF (SCLK) illustrated in FIGS. 12 and 13 to a count value of SOE\_PRD[3:0]. Hence, the SOE&POL restoring unit 74 determines a falling time of the source output enable signal SOE. As a result, the SOE&POL restoring unit 74 generates the source output enable signal SOE that is kept at a high logic level for a predetermined period of time between the previ-

ously determined rising time and the falling time determined by SOE\_PRD[3:0] and is kept at a low logic level for a period of time except the predetermined period of time.

Further, as shown in FIG. 17, the SOE&POL restoring unit 74 detects C14 bit of the real source control packet Cr to generate the polarity control signal POL. Then, after the SOE&POL restoring unit 74 keeps the polarity control signal POL at the same logic level during “i” horizontal periods, the SOE&POL restoring unit 74 inverts the polarity control signal POL. For example, the SOE&POL restoring unit 74 detects C14 bit of the real source control packet Cr to generate the polarity control signal POL and keeps the polarity control signal POL at a high logic level during 1 or 2 horizontal periods. Then, the SOE&POL restoring unit 74 inverts the polarity control signal POL to keep the polarity control signal POL at a low logic level during 1 or 2 horizontal periods. In other words, the SOE&POL restoring unit 74 may invert a logic level of the polarity control signal POL every 1 or 2 horizontal periods.

FIG. 18 illustrates a pulse width of the source output enable signal SOE determined depending on SOE\_PRD[3:0] of the real source control packet Cr.

As shown in FIG. 18, a pulse width of the source output enable signal SOE is determined depending on SOE\_PRD[3:0] of the real source control packet Cr. More specifically, the source output enable signal SOE may have a minimum pulse width when a bit value of SOE\_PRD[3:0] is “0000 (or LLLL)”. The source output enable signal SOE may have a maximum pulse width when a bit value of SOE\_PRD[3:0] is “1111 (or HHHH)”. An optimum value of the pulse width of the source output enable signal SOE may vary depending on models of liquid crystal displays. This is because a charge amount of optimum data of the liquid crystal cells may vary depending on panel properties such as a resolution and an inversion manner and also may be determined by several causes. Accordingly, the pulse width of the source output enable signal SOE has to vary so as to control a data charge time of the liquid crystal cells.

The pulse width of the source output enable signal SOE may be controlled by counting a cycle of a serial clock SCLK restored by the clock separation and data sampling unit 21 depending on SOE\_PRD[3:0]. 1 cycle of a serial clock SCLK is substantially equal to time of 1 source control data packet or 1 RGB data packet. In case of a FHD (full high definition) liquid crystal display driven at a frame frequency of 120 Hz, 1 cycle of a serial clock SCLK is approximately 27.2 ns. In case of a FHD liquid crystal display driven at a frame frequency of 60 Hz, 1 cycle of a serial clock SCLK is approximately 55.2 ns. Accordingly, as shown in FIGS. 18 and 19, in the 120 Hz FHD liquid crystal display, if a bit value of SOE\_PRD[3:0] is “0000”, the pulse width of the source output enable signal SOE is reduced to a following value:  $SCLK \times 4 = 27.2 \text{ ns} \times 4 = 108.8 \text{ ns}$ . Further, if a bit value of SOE\_PRD[3:0] is “1111”, the pulse width of the source output enable signal SOE increases to a following value:  $SCLK \times 64 = 27.2 \text{ ns} \times 64 = 1740.8 \text{ ns}$ .

FIG. 20 is a waveform diagram illustrating a reference clock REF(SCLK) restored by the clock separation and data sampling unit 21 when each of R data, G data, and B data is 10-bit data, and an RGB data output sampled depending on the reference clock REF(SCLK).

In the liquid crystal display and the method of driving the same according to the embodiment of the invention, the RGB data packet and the control data packet are not limited to the data length illustrated in FIGS. 10 to 16 and their length conversion is possible depending on a bit rate of an input image as illustrated in FIGS. 21A to 21D.

When each of R data, G data, and B data is 10-bit data, as shown in FIG. 21A, the timing controller TCON generates 1 source control packet or 1 RGB data packet as a bit stream including DUM, CLK, R1 to R10, G1 to G5, DE DUM, DE, G6 to G10, and B1 to B10 for T hours. The clock separation and data sampling unit 21 of each of the source drive ICs SDIC#1 to SDIC#8 generates 34 edge clocks and 34 center clocks from the 1 source control/RGB data packet received from the timing controller TCON and samples source control bits or RGB data bits in conformity with the center clocks.

When each of R data, G data, and B data is 8-bit data, as shown in FIG. 21B, the timing controller TCON generates 1 source control/RGB data packet as a bit stream including DUM, CLK, R1 to R8, G1 to G4, DE DUM, DE, G5 to G8, and B1 to B8 for  $T \times (28/34)$  hours. The clock separation and data sampling unit 21 of each of the source drive ICs SDIC#1 to SDIC#8 generates 28 edge clocks and 28 center clocks from the 1 source control/RGB data packet received from the timing controller TCON and samples source control bits or RGB data bits in conformity with the center clocks.

When each of R data, G data, and B data is 6-bit data, as shown in FIG. 21C, the timing controller TCON generates 1 source control/RGB data packet as a bit stream including DUM, CLK, R1 to R6, G1 to G3, DE DUM, DE, G4 to G6, and B1 to B6 for  $T \times (22/34)$  hours. The clock separation and data sampling unit 21 of each of the source drive ICs SDIC#1 to SDIC#8 generates 22 edge clocks and 22 center clocks from the 1 source control/RGB data packet received from the timing controller TCON and samples source control bits or RGB data bits in conformity with the center clocks.

When each of R data, G data, and B data is 12-bit data, as shown in FIG. 21D, the timing controller TCON generates 1 source control/RGB data packet as a bit stream including DUM, CLK, R1 to R12, G1 to G6, DE DUM, DE, G7 to G12, and B1 to B12 for  $T \times (40/34)$  hours. The clock separation and data sampling unit 21 of each of the source drive ICs SDIC#1 to SDIC#8 generates 40 edge clocks and 40 center clocks from the 1 source control/RGB data packet received from the timing controller TCON and samples source control bits or RGB data bits in conformity with the center clocks.

The timing controller TCON decides a bit rate of input data and may automatically convert the length of the RGB/control data packet as illustrated in FIGS. 21A to 21D.

A liquid crystal display according to another embodiment of the invention generates a preamble signal including a plurality of pulse groups each having a different pulse width and a different cycle as Phase 1 signals and thus may more securely lock a phase and a frequency of internal clock pulses output from a PLL of a clock separation and data sampling unit 21.

FIGS. 22 and 23 are waveform diagrams illustrating Phase 1 signals according to another embodiment of the invention.

As shown in FIGS. 22 and 23, Phase 1 signals include a phase 1-1 signal and a phase 1-2 signal. The phase 1-1 signal is a signal, in which 1 cycle of the phase 1-1 signal is set at the same time as 1 source control/RGB data packet, in the same manner as the above-described preamble signal. A frequency of the phase 1-2 signal is greater than a frequency of the phase 1-1 signal, and a cycle of the phase 1-2 signal is equal to or less than  $\frac{1}{2}$  of a cycle of the phase 1-1 signal. The phase 1-2 signal may have a waveform in which two pulse groups P1 and P2 each having a different phase and a different frequency are alternately generated. A frequency of the first pulse group P1 is equal to or greater than two times a frequency of a pulse row generated in the form of the phase 1-1 signal, and a frequency of the second pulse group P2 is equal to or greater than two times the frequency of the first pulse group P1. As

shown in FIGS. 22 and 23, while the PLL 64 of the clock separation and data sampling unit 21 tracks pulses whose a frequency is greater than the frequency of the phase 1-1 signal and a phase regularly changes, the clock separation and data sampling unit 21 may more stably and more rapidly lock a phase and a frequency of internal clock pulses than the pre-amble signal of the low frequency illustrated in FIG. 10.

As consumers have demanded operation improvement of LCD modules, LCD module makers may provide the source drive ICs SDIC#1 to SDIC#8 with various options so that the consumers may directly control detailed operations of the LCD modules. For this, in the related art, the makers provided the source drive ICs SDIC#1 to SDIC#8 with a plurality of option pins and connected pull-up resistors or pull-down resistors to the option pins of the source drive ICs SDIC#1 to SDIC#8 whenever necessary. Further, in the related art, option operations of the source drive ICs SDIC#1 to SDIC#8 were controlled by applying a power source voltage Vcc or a ground level voltage GND to the LCD module. However, in the related art, the chip size of the source drive ICs SDIC#1 to SDIC#8 increased because of the plurality of option pins, and also the PCB size increased because of pull-up/pull-down resistors connected to the option pins and lines.

A liquid crystal display according to another embodiment of the invention may further reduce the chip size of the source drive ICs SDIC#1 to SDIC#8 and the PCB size by adding signals for controlling various operations of the source drive ICs SDIC#1 to SDIC#8 during a predetermined period of Phase 2. For this, the liquid crystal display according to another embodiment of the invention generates control option information for controlling various operations of the source drive ICs SDIC#1 to SDIC#8, such as PWRC1/2, MODE, SOE\_EN, PACK\_EN, CHMODE, CID1/2, H\_2DOT, as a separate source control packet. The source control packet including the control option information may be inserted into a predetermined period of Phase 2 and may be transferred to the source drive ICs SDIC#1 to SDIC#8 through the pairs of data bus lines.

PWRC1/2 is option information determining an amplification ratio of an output buffer of the source drive ICs SDIC#1 to SDIC#8 to select a power capacitance of the source drive ICs SDIC#1 to SDIC#8, as indicated in the following Table 1.

TABLE 1

PWRC1/2 = 11 (HH)	High Power Mode
PWRC1/2 = 10 (HL)	Normal Power Mode
PWRC1/2 = 01 (LH)	Low Power Mode
PWRC1/2 = 00 (LL)	Ultra Low Power Mode

MODE is option information determining whether to enable or disable an output of a charge share voltage during a high logic level period of the source output enable signal SOE, as indicated in the following Table 2.

TABLE 2

MODE = 1 (H)	Hi_Z Mode Operation (charge share output disable)
MODE = 0 (L)	Charge-share mode operation (charge share output enable)

SOE\_EN is option information determining whether to receive the source output enable signal SOE in the form embedded in the RGB digital video data or through separate lines from the source drive ICs SDIC#1 to SDIC#8, as indicated in the following Table 3.

TABLE 3

	PACK_EN = 0 (L)	PACK_EN = 1 (H)
SOE_EN = 0 (L)	Forbidden	Use internal SOE
SOE_EN = 1 (H)		Use external SOE

PACK\_EN is option information determining whether to receive the polarity control signal POL and the gate start pulse GSP to be transferred to the gate drive ICs GDIC#1 to GDIC#4 in the form embedded in the RGB digital video data or through separate lines from the source drive ICs SDIC#1 to SDIC#8, as indicated in the following Table 4.

TABLE 4

PACK_EN = 1(H)	Enable control packet
PACK_EN = 0(L)	Disable control packet (Ignore the value of SOE_EN)

CHMODE is option information determining the number of output channels of the source drive ICs SDIC#1 to SDIC#8 in conformity with a resolution of the liquid crystal display, as indicated in the following Table 5.

TABLE 5

CHMODE = 1(H)	690 Ch. Outputs(691~720 Ch. Disable)
CHMODE = 0(L)	720 Ch. Outputs

CID1/2 is option information giving a chip identification code CID to each of the source drive ICs SDIC#1 to SDIC#8 to independently control the source drive ICs SDIC#1 to SDIC#8, as indicated in the following Table 6. A bit rate of CID1/2 may be adjusted depending on the number of source drive ICs. Further, as described above, the source drive ICs SDIC#1 to SDIC#8 may be individually controlled through I<sup>2</sup>C communication using the timing control TCON and the pair of control lines SCL/SDA. The LCD module makers may select among the control method using option information CID1/2 and the control method using through I<sup>2</sup>C communication.

TABLE 6

CID1/2 = 00 (LL)	Assigning to SDIC#1
CID1/2 = 01 (LH)	Assigning to SDIC#2
CID1/2 = 10 (HL)	Assigning to SDIC#3
CID1/2 = 11 (HH)	Assigning to SDIC#4

H\_2DOT is option information controlling a horizontal polarity cycle of the positive/negative analog video data voltage output from the source drive ICs SDIC#1 to SDIC#8, as indicated in the following Table 7. For example, if a bit value of H\_2DOT is "1 (H)", the source drive ICs SDIC#1 to SDIC#8 control a polarity of the data voltage in a horizontal 2-dot inversion manner. In the horizontal 2-dot inversion manner, the source drive ICs SDIC#1 to SDIC#8 output the data voltages of the same polarity to the two adjacent data lines. Namely, a polarity of the data voltage is inverted every the two adjacent data lines in the horizontal 2-dot inversion manner. Hence, the polarities of the data voltages to which the horizontally adjacent liquid crystal cells are charged are controlled as follows: "--+-, . . . , +---+(or +---, . . . , -+++)". Further, if a bit value of H\_2DOT is "0 (L)", the source drive ICs SDIC#1 to SDIC#8 control a polarity of the data voltage in a horizontal 1-dot inversion manner. In the horizontal 1-dot inversion manner, the source drive ICs SDIC#1 to SDIC#8

invert a polarity of the data voltage supplied to the adjacent data lines every 1 data line. Hence, the polarities of the data voltages to which the horizontally adjacent liquid crystal cells are charged are controlled as follows: “-+++, . . . , +--+ (or +-+-, . . . , -+--+)”.

TABLE 7

H_2DOT = 1(H)	Horizontal 2-Dot inversion Enable
H_2DOT = 0(L)	Horizontal 2-Dot inversion Disable

In the embodiments of the invention, the timing controller TCON has to receive a feedback lock signal of a high logic level from the last source drive IC SDIC#8, so that the timing controller TCON proceeds to Phase 2. More specifically, if PLL locking operations of all of the source drive ICs SDIC#1 to SDIC#8 are not completed, the timing controller TCON repeatedly generates only the preamble signal of Phase 1, and the source drive ICs SDIC#1 to SDIC#8 do not output the data voltage. Accordingly, if the timing controller TCON does not receive the feedback lock signal, an individual driving state of the source drive ICs SDIC#1 to SDIC#8 cannot be confirmed. However, a defective source drive IC among the source drive ICs SDIC#1 to SDIC#8 needs to be confirmed, and also a driving state of each of the source drive ICs SDIC#1 to SDIC#8 needs to be confirmed.

A liquid crystal display according to another embodiment of the invention provides a test mode and inputs a feedback lock signal to the timing controller TCON in the test mode to induce an output of the data voltage of the source drive ICs SDIC#1 to SDIC#8, so as to confirm an individual driving state of the source drive ICs SDIC#1 to SDIC#8. For this, in the liquid crystal display according to another embodiment of the invention, as shown in FIG. 24, a selection unit SEL is additionally installed inside or outside the timing controller TCON.

More specifically, a first input terminal of the selection unit SEL is connected to the feedback lock check line LCS2, and a second input terminal of the selection unit SEL is connected to an input terminal of a test mode enable signal TEST. The selection unit SEL may be implemented as an OR gate outputting at least one of a feedback lock signal “Lock Out” and the test mode enable signal TEST. Even if the feedback lock signal “Lock Out” of a high logic level is not input to the timing controller TCON, the selection unit SEL inputs the test mode enable signal TEST of a high logic level to a data transfer module of the timing controller TCON if the test mode enable signal TEST of the high logic level is input. Accordingly, even if the timing controller TCON does not receive the feedback lock signal in the test mode, the timing controller TCON may proceed to step S8 of FIG. 6 to transfer Phase 2 signals and Phase 3 signals to the source drive ICs SDIC#1 to SDIC#8. The timing controller TCON codes test data extracting from an internal memory in the test mode to the RGB data packet of Phase 3 and transfers the coded test data to the source drive ICs SDIC#1 to SDIC#8. An operator watches an image of the test data displayed on the liquid crystal display panel in the test mode and may confirm the individual driving state of the source drive ICs SDIC#1 to SDIC#8 and whether or not there is a defective source drive IC among the source drive ICs SDIC#1 to SDIC#8.

As described above, in the liquid crystal display and the method of driving the same according to the embodiments of the invention, a clock generating circuit for data sampling is embedded inside each of the source drive ICs, and the source control packet and the RGB data packet are transferred to each of the source drive ICs through the pair of data bus lines.

Hence, the number of data transfer lines required between the timing controller and the source drive ICs can be reduced, and source timing control lines can be removed. Furthermore, in the liquid crystal display and the method of driving the same according to the embodiments of the invention, because option informations controlling option operations of the source drive ICs are transferred through the pair of data bus lines, option pins of the source drive ICs, and resistors and lines connected to the option pins can be removed. The individual driving state of the source drive ICs and whether or not there is a defective source drive IC among the source drive ICs can be confirmed by providing the test mode. Furthermore, in the liquid crystal display and the method of driving the same according to the embodiments of the invention, the control lines are connected between the timing controller and the source drive ICs, and the timing controller transfers the chip identification code and the control data to the source drive ICs through the control lines. Hence, the source drive ICs can be individually controlled and thus can independently perform a debugging operation.

Any reference in this specification to “one embodiment,” “an embodiment,” “example embodiment,” etc., means that a particular feature, structure, or characteristic described in connection with the embodiment is included in at least one embodiment of the invention. The appearances of such phrases in various places in the specification are not necessarily all referring to the same embodiment. Further, when a particular feature, structure, or characteristic is described in connection with any embodiment, it is submitted that it is within the purview of one skilled in the art to effect such feature, structure, or characteristic in connection with other ones of the embodiments.

Although embodiments have been described with reference to a number of illustrative embodiments thereof, it should be understood that numerous other modifications and embodiments can be devised by those skilled in the art that will fall within the scope of the principles of this disclosure. More particularly, various variations and modifications are possible in the component parts and/or arrangements of the subject combination arrangement within the scope of the disclosure, the drawings and the appended claims. In addition to variations and modifications in the component parts and/or arrangements, alternative uses will also be apparent to those skilled in the art.

What is claimed is:

1. A liquid crystal display comprising:  
a timing controller;

N source drive integrated circuits (ICs), where N is an integer equal to or greater than 2;

N pairs of data bus lines, each of which connects the timing controller to each of the N source drive ICs in a point-to-point manner;

a lock check line that connects a first source drive IC of the N source drive ICs to the timing controller and cascade-connects the N source drive ICs to one another; and  
a feedback lock check line that connects a last source drive IC of the N source drive ICs to the timing controller,

wherein the timing controller serially transfers a preamble signal, in which a plurality of bits having a high logic level are successively arranged and then a plurality of bits having a low logic level are successively arranged, to each of the N source drive ICs through each of the N pairs of data bus lines, transfers a lock signal indicating that a phase of an internal clock pulse output from each of the N source drive ICs is locked to the first source drive IC through the lock check line, receives a feedback signal of the lock signal from the last source drive IC

23

through the feedback lock check line, and serially transfers at least one source control packet for controlling a data voltage output from each of the N source drive ICs to each of the N source drive ICs through each of the N pairs of data bus lines.

2. The liquid crystal display of claim 1, wherein after the timing controller serially transfers the source control packet, the timing controller serially transfers at least one RGB data packet to each of the N source drive ICs through each of the N pairs of data bus lines.

3. The liquid crystal display of claim 2, wherein the RGB data packet successively includes clock bits, first RGB data bits, internal data enable clock bits, and second RGB data bits in the order named.

4. The liquid crystal display of claim 3, wherein each of the N source drive ICs restores a first reference clock from the preamble signal to output the first reference clock and a first internal clock pulse with a locked phase,

wherein if the phases of the first internal clock pulses output from the N source drive ICs are locked, the last source drive IC transfers the feedback signal of the lock signal to the timing controller through the feedback lock check line, and then each of the N source drive ICs restores source control data from the source control packet,

wherein each of the N source drive ICs restores a second reference clock from the clock bits included in the RGB data packet, samples RGB data included in the RGB data packet based on the second reference clock and a second internal clock pulse with a locked phase, and converts the RGB data into a positive or negative data voltage depending on the source control data to output the positive/negative data voltage.

5. The liquid crystal display of claim 4, wherein the source control data includes:

a polarity control signal determining a polarity of the positive/negative data voltage that is output from each of the N source drive ICs and is supplied to data lines of a liquid crystal display panel; and

a source output enable signal that controls an output timing of the positive/negative data voltage output from each of the N source drive ICs.

6. The liquid crystal display of claim 5, wherein the source control data includes:

activation information of the source output enable signal; pulse width information of the source output enable signal; and

activation information of the polarity control signal.

7. The liquid crystal display of claim 6, wherein a pulse width of the source output enable signal is determined by a multiplication of a length of one of the source control packet and the RGB data packet by "i", where "i" is a natural number, depending on the pulse width information of the source output enable signal.

8. The liquid crystal display of claim 5, wherein the timing controller generates at least one second source control packet including at least one of PWRC1/2 option information determining an amplification ratio of an output buffer of each of the N source drive ICs, MODE option information determining an output of a charge share voltage of each of the N source drive ICs, SOE\_EN option information determining a receiving path of the source output enable signal, PACK\_EN option information determining a receiving path of the polarity control signal, CHMODE option information determining the number of output channels of the N source drive ICs, CID1/2 option information that gives a chip identification code to each of the N source drive ICs to independently control the N

24

source drive ICs, and H\_2DOT option information determining a horizontal polarity cycle of the positive/negative data voltage output from the N source drive ICs,

wherein the timing controller transfers the second source control packet to each of the N source drive ICs through each of the N pairs of data bus lines.

9. The liquid crystal display of claim 2, wherein after the timing controller receives at least one of the feedback signal of the lock signal and a predetermined test mode enable signal, the timing controller serially transfers the source control packet and the RGB data packet to each of the N source drive ICs through each of the N pairs of data bus lines.

10. The liquid crystal display of claim 1, wherein the preamble signal includes:

a first pulse row; and

a second pulse row that is generated subsequent to the first pulse row at a frequency greater than a frequency of the first pulse row.

11. The liquid crystal display of claim 10, wherein the second pulse row includes:

third pulse rows each having a frequency greater than the frequency of the first pulse row; and

fourth pulse rows generated between the third pulse rows, the fourth pulse rows each having a frequency greater than the frequency of the third pulse rows.

12. The liquid crystal display of claim 1, further comprising a pair of control lines connecting in parallel the timing controller to the N source drive ICs,

wherein the timing controller transfers a chip identification code for individually identifying the N source drive ICs and control data controlling functions of each of the N source drive ICs to the N source drive ICs through the pair of control lines.

13. A method of driving a liquid crystal display including a timing controller and N source drive integrated circuits (ICs), where N is an integer equal to or greater than 2, the method comprising:

generating a preamble signal, in which a plurality of bits having a high logic level are successively arranged and then a plurality of bits having a low logic level are successively arranged, from the timing controller;

transferring the preamble signal serially to each of the N source drive ICs through each of N pairs of data bus lines connecting the timing controller to the N source drive ICs in a point-to-point manner;

generating a lock signal indicating that a phase of an internal clock pulse output from each of the N source drive ICs is locked from the timing controller;

transferring the lock signal to a first source drive IC of the N source drive ICs through a lock check line that connects the first source drive IC to the timing controller and cascade-connects the N source drive ICs to one another; generating a feedback signal of the lock signal from a last source drive IC of the N source drive ICs;

transferring the feedback signal of the lock signal to the timing controller through a feedback lock check line connecting the last source drive IC to the timing controller;

generating at least one source control packet for controlling a data voltage output from each of the N source drive ICs from the timing controller; and

transferring the source control packet serially to each of the N source drive ICs through each of the N pairs of data bus lines.

25

14. The method of claim 13, further comprising:  
generating at least one RGB data packet from the timing controller after serially transferring the source control packet; and

transferring the RGB data packet serially to each of the N source drive ICs through each of the N pairs of data bus lines.

15. The method of claim 14, wherein the RGB data packet successively includes clock bits, first RGB data bits, internal data enable clock bits, and second RGB data bits in the order named.

16. The method of claim 14, further comprising:

restoring a first reference clock from the preamble signal inside each of the N source drive ICs to output the first reference clock and a first internal clock pulse, with a locked phase, from each of the N source drive ICs;

transferring the feedback signal of the lock signal generated by the last source drive IC to the timing controller through the feedback lock check line, if the phases of the first internal clock pulses output from the N source drive ICs are locked;

restoring source control data from the source control packet inside each of the N source drive ICs;

restoring a second reference clock from clock bits included in the RGB data packet inside each of the N source drive ICs to output the second reference clock and a second internal clock pulse, whose a phase is locked, from each of the N source drive ICs;

sampling RGB data included in the RGB data packet based on the second internal clock pulses; and

26

converting the RGB data into a positive or negative data voltage depending on the source control data inside each of the N source drive ICs to output the positive/negative data voltage.

17. The method of claim 16, wherein the source control data includes:

a polarity control signal determining a polarity of the positive/negative data voltage that is output from each of the N source drive ICs and is supplied to data lines of a liquid crystal display panel; and

a source output enable signal that controls an output timing of the positive/negative data voltage output from each of the N source drive ICs.

18. The method of claim 17, wherein the source control data includes:

activation information of the source output enable signal; pulse width information of the source output enable signal; and

activation information of the polarity control signal.

19. The method of claim 18, wherein a pulse width of the source output enable signal is determined by a multiplication of a length of one of the source control packet and the RGB data packet by "i", where "i" is a natural number, depending on the pulse width information of the source output enable signal.

20. The method of claim 13, wherein the preamble signal includes:

a first pulse row; and

a second pulse row that is generated subsequent to the first pulse row at a frequency greater than a frequency of the first pulse row.

\* \* \* \* \*

专利名称(译)	液晶显示器及其驱动方法		
公开(公告)号	<a href="#">US7898518</a>	公开(公告)日	2011-03-01
申请号	US12/461652	申请日	2009-08-19
[标]申请(专利权)人(译)	HONG JINCHEOL 康PILSUNG PARK MANGYU KOH GEUNWOO		
申请(专利权)人(译)	HONG JINCHEOL 康PILSUNG PARK MANGYU KOH GEUNWOO		
当前申请(专利权)人(译)	LG DISPLAY CO. , LTD.		
[标]发明人	HONG JINCHEOL KANG PILSUNG PARK MANGYU KOH GEUNWOO		
发明人	HONG, JINCHEOL KANG, PILSUNG PARK, MANGYU KOH, GEUNWOO		
IPC分类号	G09G3/36		
CPC分类号	G09G3/3611 G09G3/006 G09G2310/08 G09G2300/0426 G09G3/3688		
优先权	1020080127456 2008-12-15 KR		
其他公开文献	US20100149082A1		
外部链接	<a href="#">Espacenet</a> <a href="#">USPTO</a>		

摘要(译)

公开了一种液晶显示器及其驱动方法。液晶显示器包括定时控制器，N个源驱动集成电路（IC），其中N是等于或大于2的整数，N对数据总线，每个数据总线连接定时控制器到N源中的每一个以点对点的方式驱动IC，锁定检查线将N个源驱动IC的第一个源驱动IC连接到时序控制器，并将N个源驱动IC级联连接，并进行反馈锁定检查将N个源驱动IC的最后一个源驱动IC连接到时序控制器的线路。

