



US 20050046769A1

(19) **United States**

(12) **Patent Application Publication**
Yi et al.

(10) **Pub. No.: US 2005/0046769 A1**
(43) **Pub. Date: Mar. 3, 2005**

(54) **TRANSFLECTIVE LIQUID CRYSTAL DISPLAY DEVICE HAVING A COLOR FILTER AND METHOD FOR FABRICATING THEREOF**

Related U.S. Application Data

(62) Division of application No. 10/029,967, filed on Dec. 31, 2001, now Pat. No. 6,809,791.

(75) Inventors: **Joog-Hoo Yi**, Seoul (KR); **Oh Nam Kwon**, Cheonan-shi (JP); **Kyoung-Su Ha**, Seoul (KR)

(30) **Foreign Application Priority Data**

Feb. 1, 2001 (KR)..... 2001-4937
Feb. 2, 2001 (KR)..... 2001-5044

Correspondence Address:
BIRCH STEWART KOLASCH & BIRCH
PO BOX 747
FALLS CHURCH, VA 22040-0747 (US)

Publication Classification

(51) **Int. Cl.⁷** **G02F 1/1335**
(52) **U.S. Cl.** **349/106; 349/114**

(73) Assignee: **LG. Philips LCD Co., Ltd.**

(57) **ABSTRACT**

A color filter substrate for a liquid crystal display device and method of fabricating the color filter substrate are provided. The color filter substrate includes a base substrate having a transmissive portion and a reflective portion, the transmissive portion having a groove, a color filter layer on the base substrate, and a black matrix on the color filter layer.

(21) Appl. No.: **10/952,780**

(22) Filed: **Sep. 30, 2004**

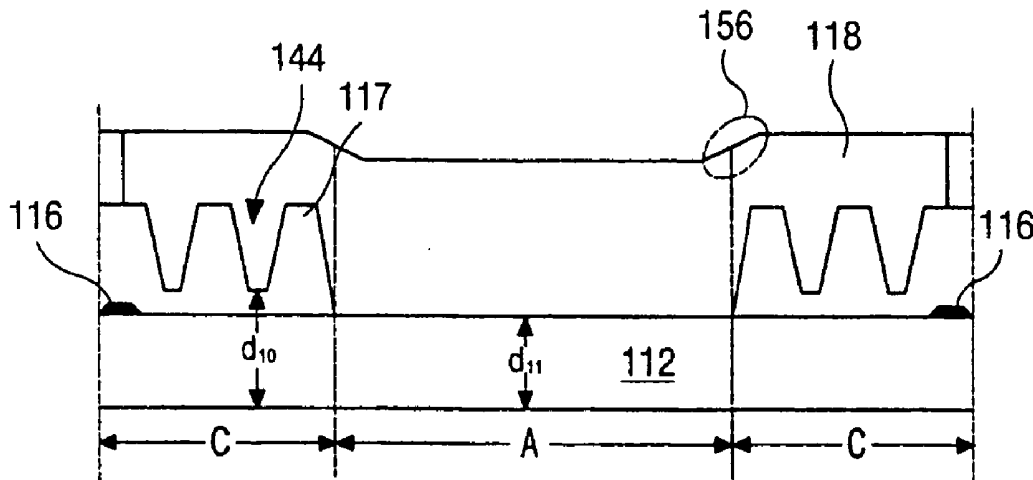

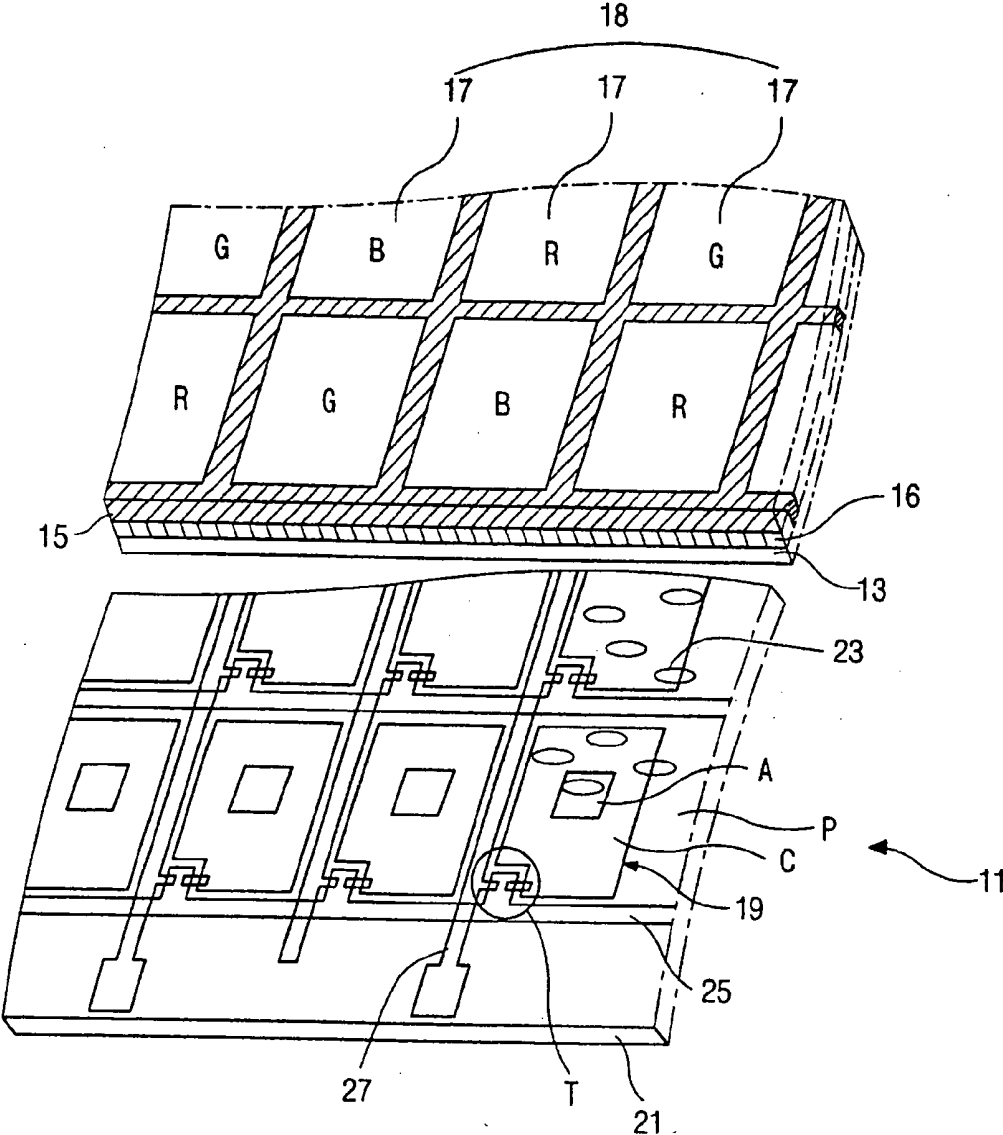

(related art)
FIG. 1

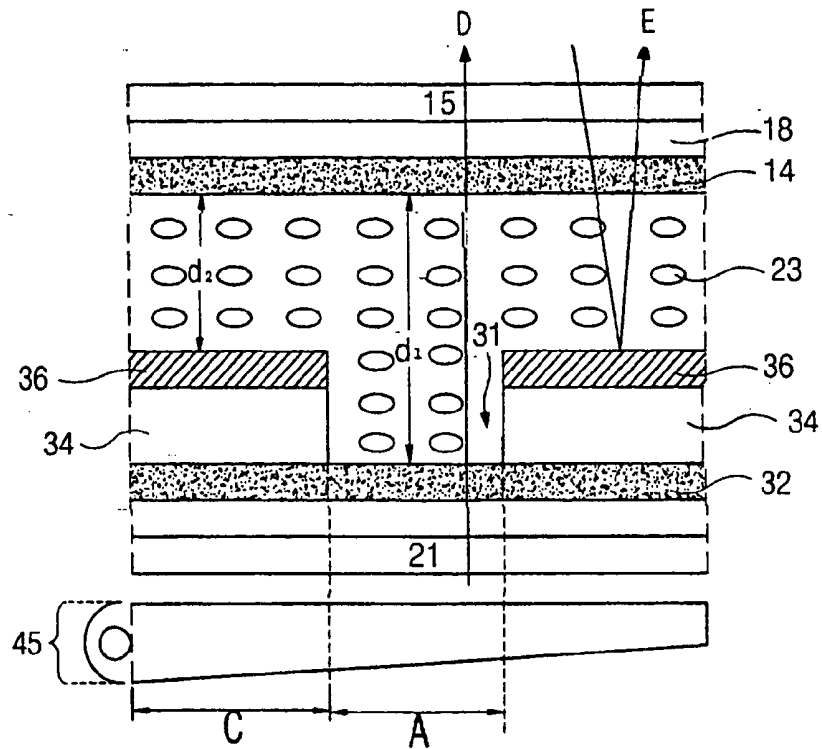

(related art)
FIG. 2

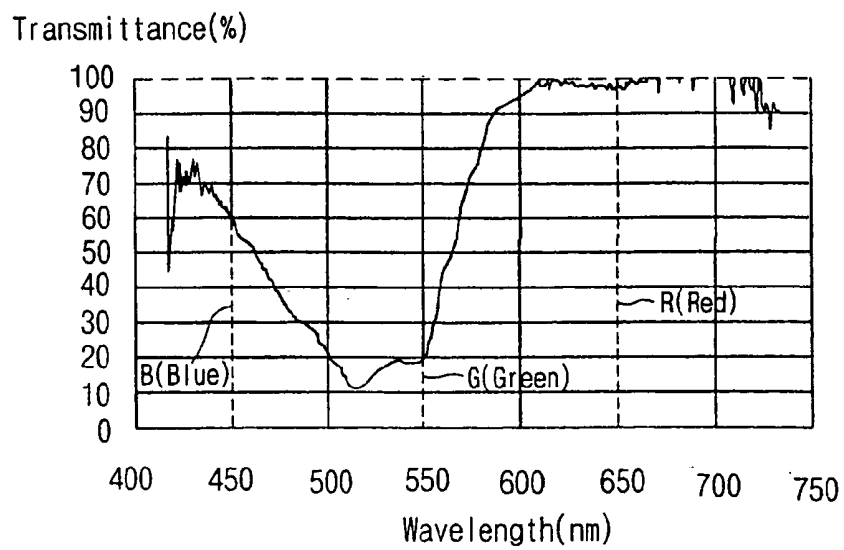

(related art)
FIG. 3A

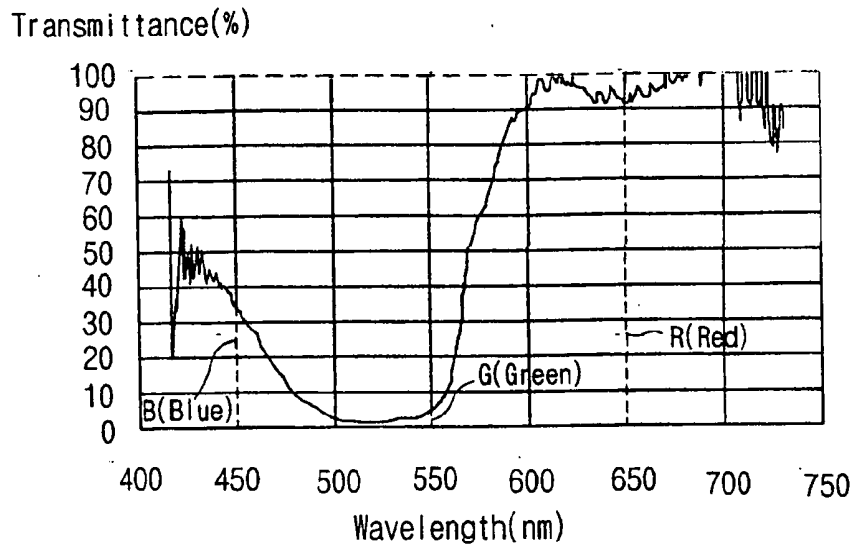

(related art)
FIG. 3B

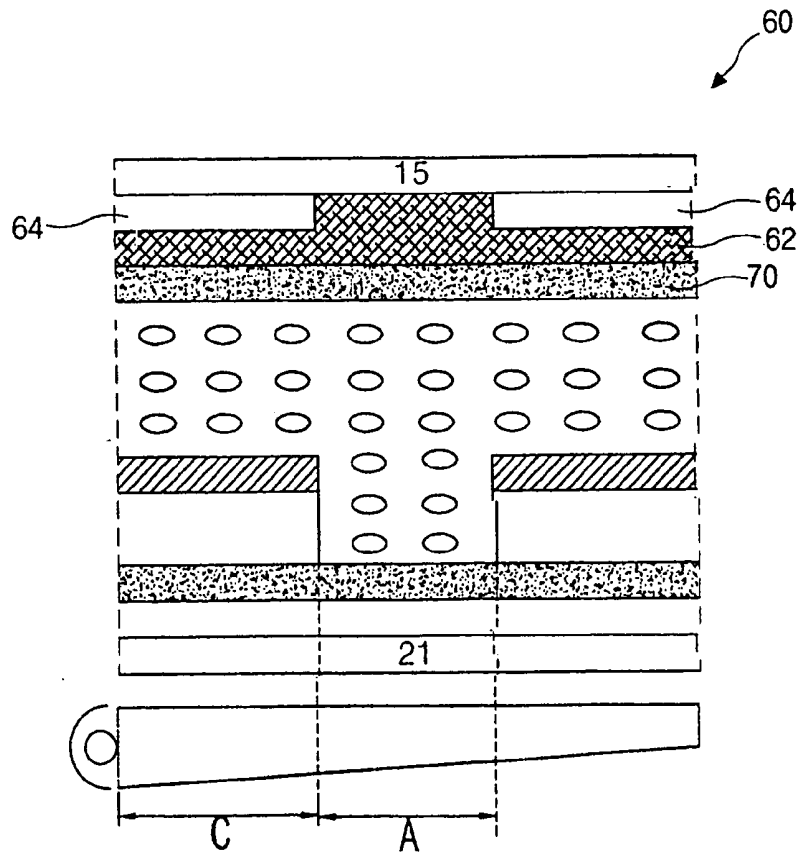

(related art)
FIG. 4

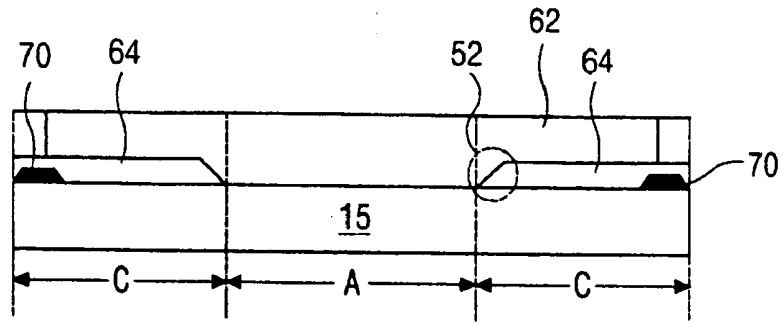

(related art)
FIG. 5A

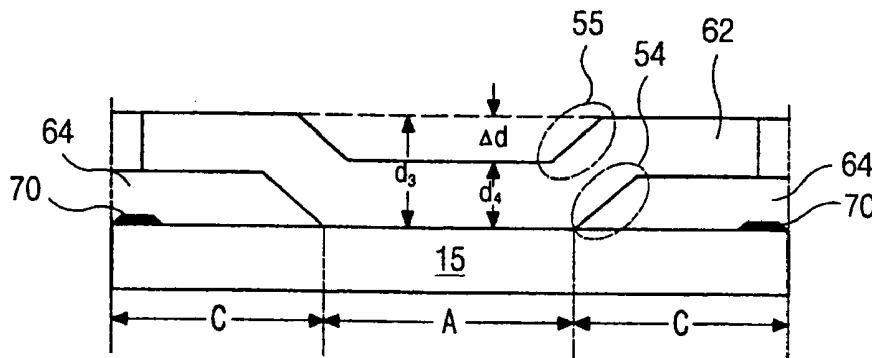

(related art)
FIG. 5B

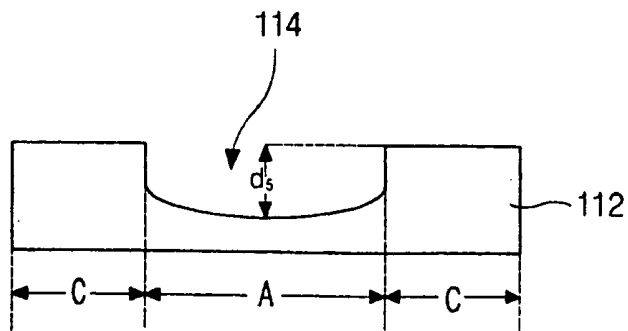

FIG. 6A

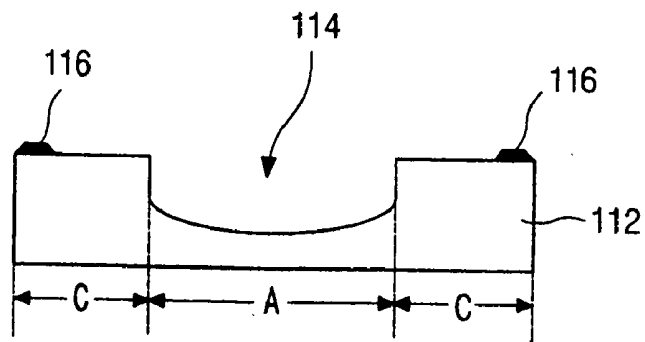

FIG. 6B

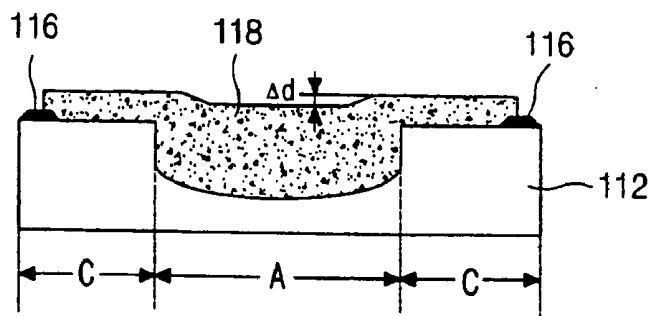

FIG. 6C

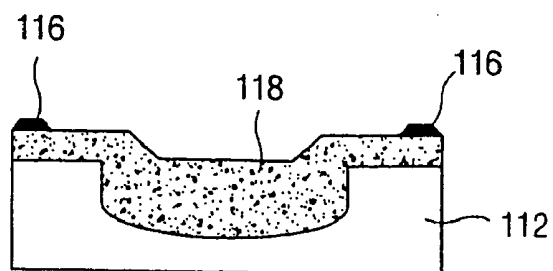

FIG. 7

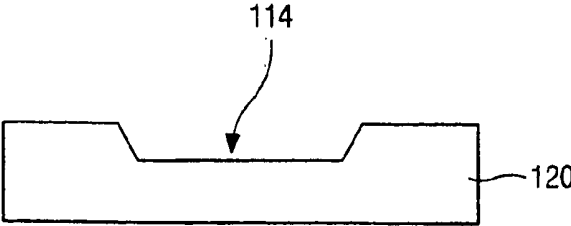

FIG. 8A

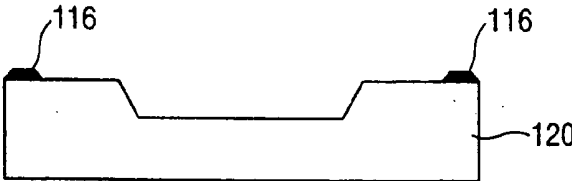

FIG. 8B

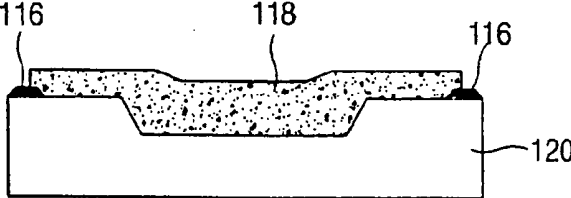

FIG. 8C

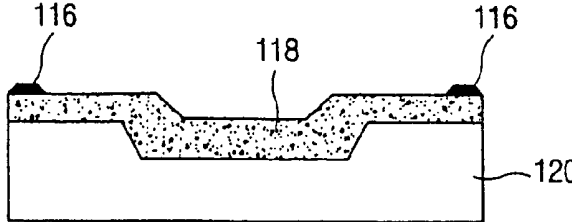

FIG. 9

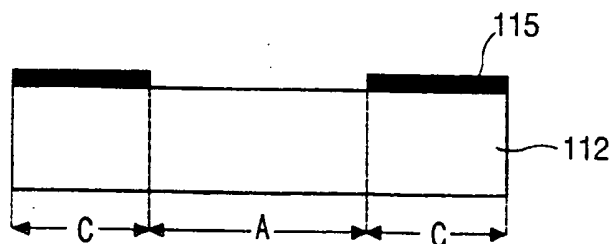

FIG. 10A

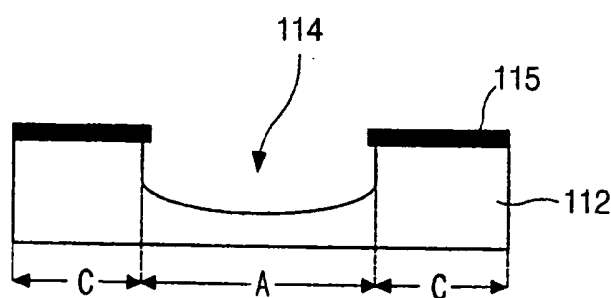

FIG. 10B

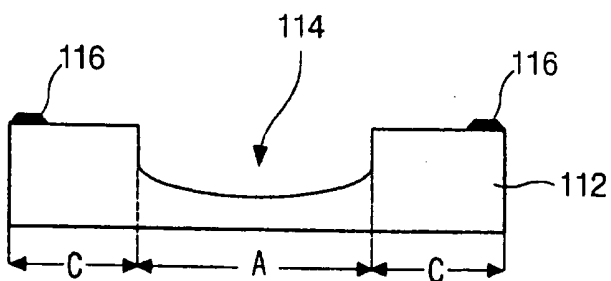

FIG. 10C

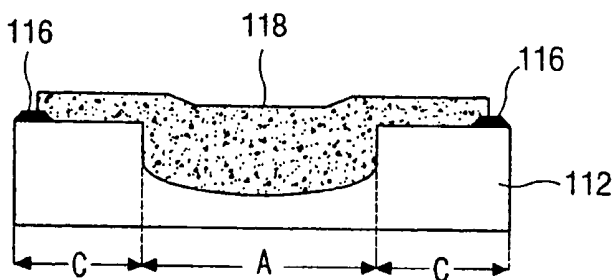

FIG. 10D

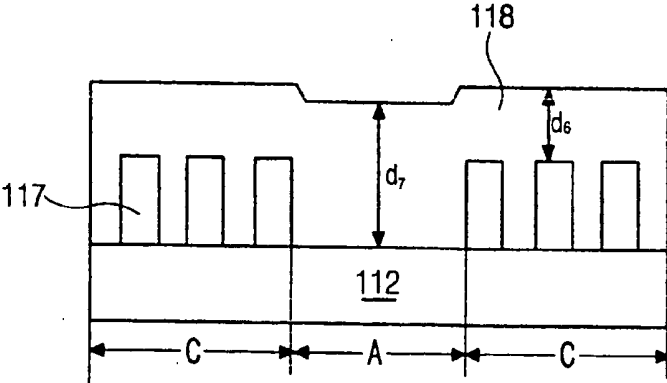

FIG. 11

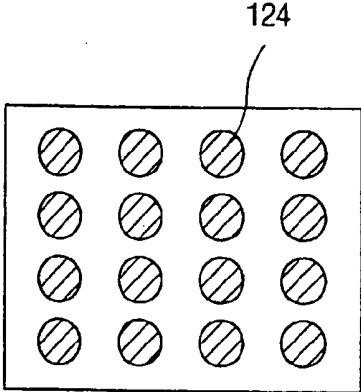

FIG. 12A

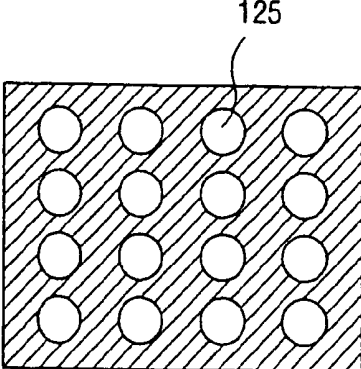

FIG. 12B

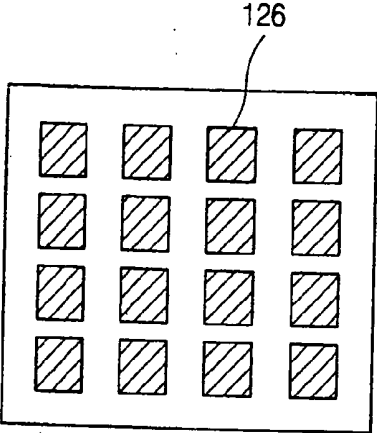

FIG. 12C

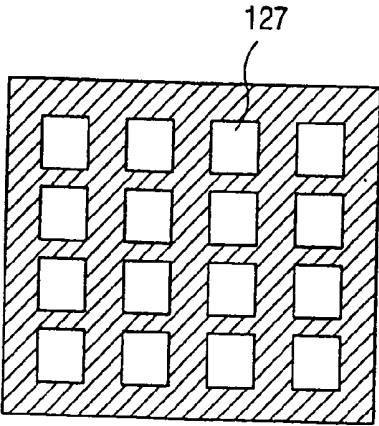

FIG. 12D

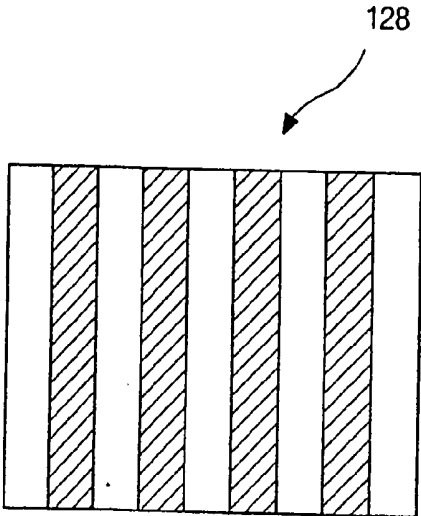

FIG. 12E

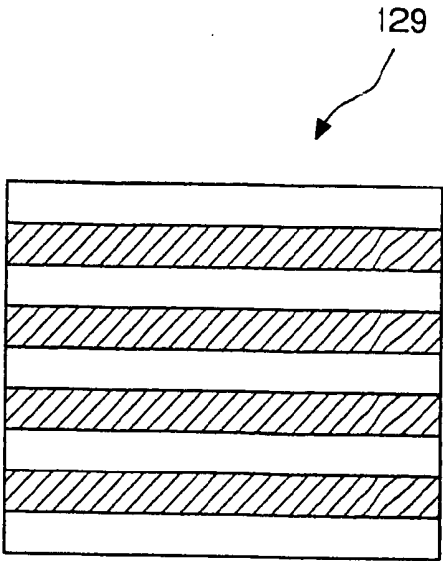

FIG. 12F

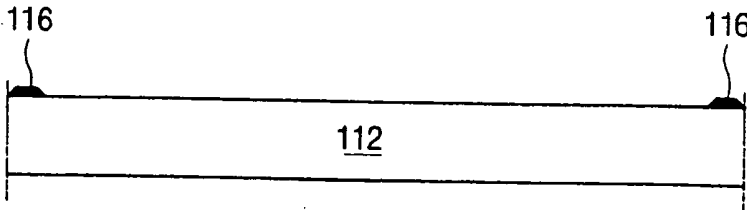

FIG. 13A

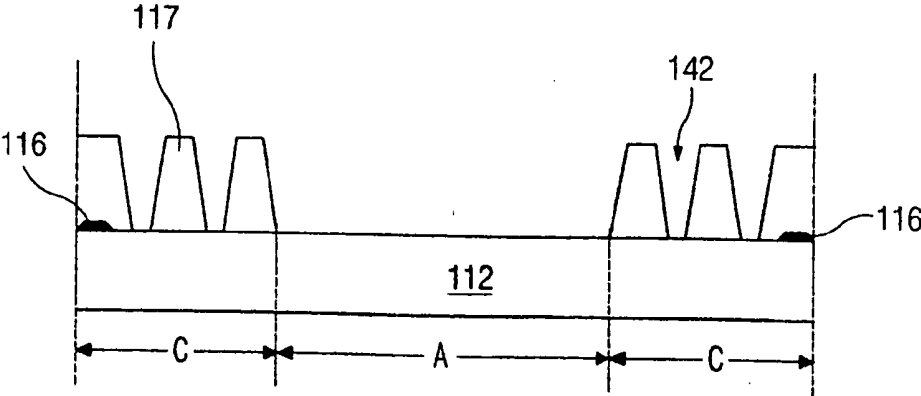

FIG. 13B

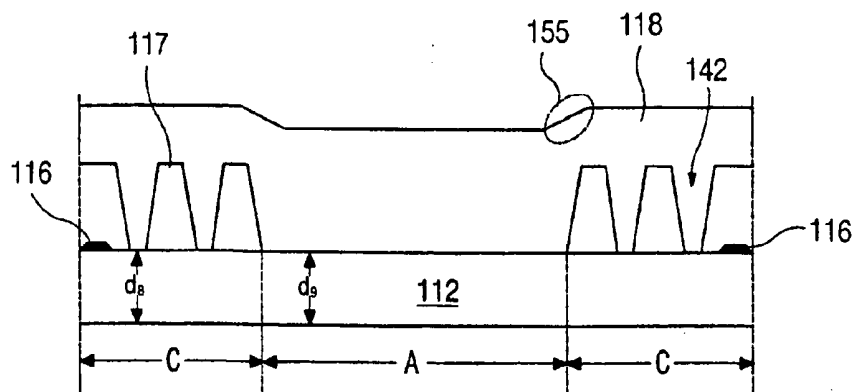

FIG. 13C

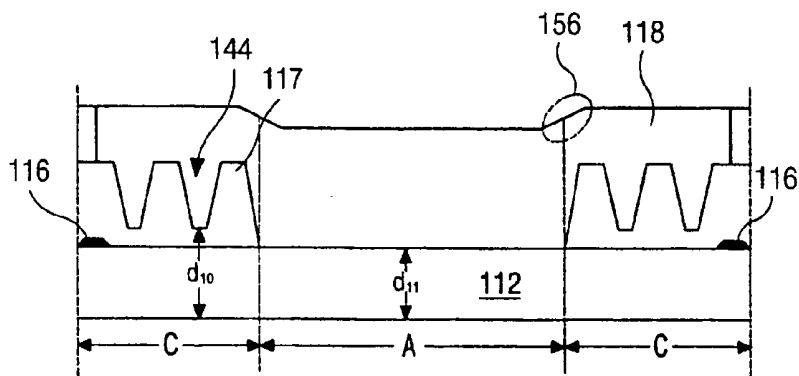

FIG. 14

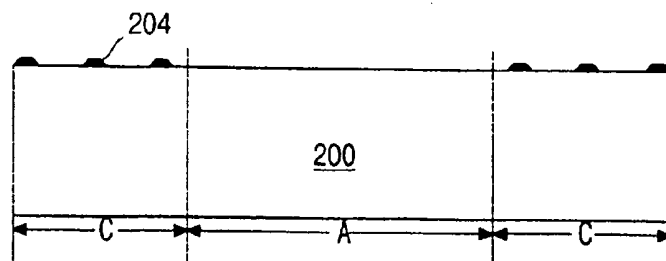

FIG. 15A

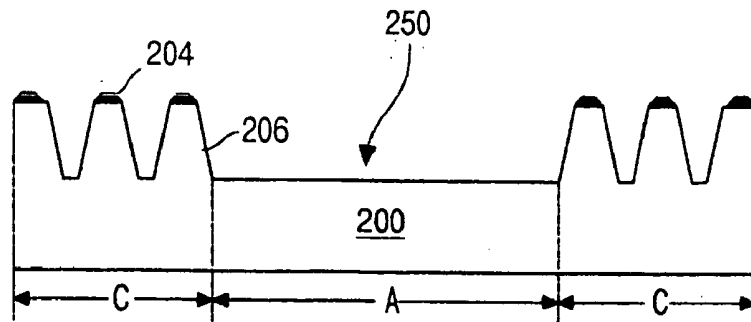

FIG. 15B

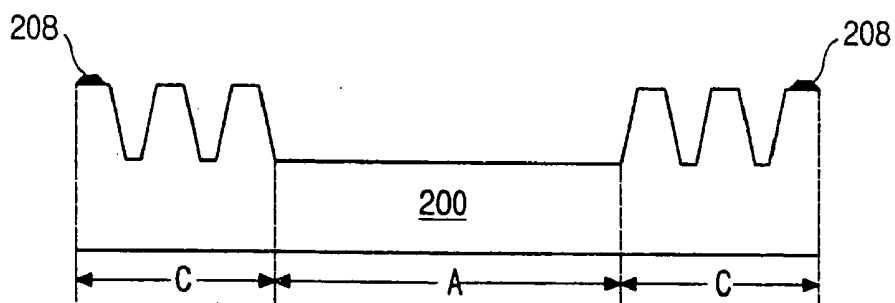

FIG. 15C

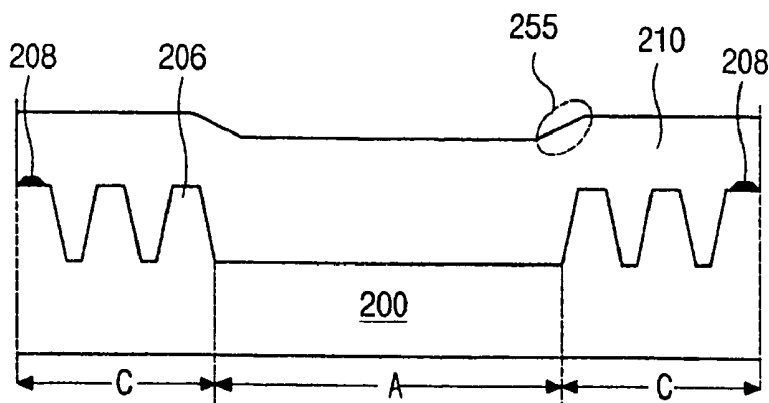

FIG. 15D

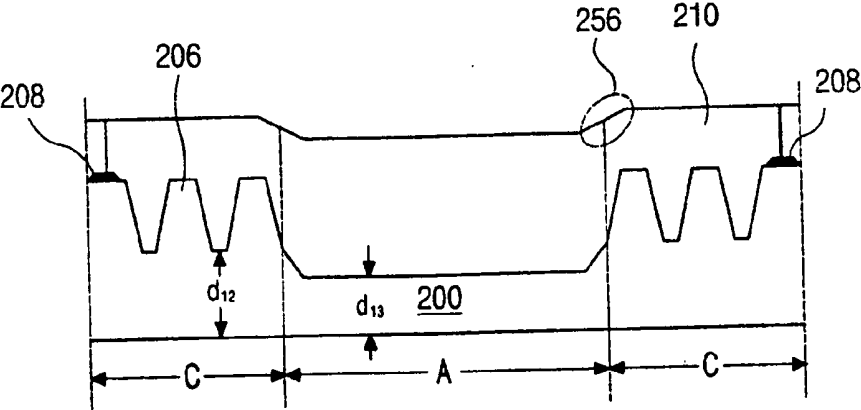

FIG. 16

**TRANSFLECTIVE LIQUID CRYSTAL DISPLAY
DEVICE HAVING A COLOR FILTER AND
METHOD FOR FABRICATING THEREOF**

CROSS REFERENCE

[0001] This application is a Divisional of co-pending U.S. application Ser. No. 10/029,967, filed on Dec. 31, 2001 (now allowed), and for which priority is claimed under 35 U.S.C. § 120; and this application claims the benefit of Korean Patent Applications No. 2001-4937, filed on Feb. 1, 2001 and No. 2001-5044, filed on Feb. 2, 2001, under 35 U.S.C. § 119. The entirety of each of these applications is hereby incorporated by reference.

BACKGROUND OF THE INVENTION

[0002] 1. Field of the Invention

[0003] The present invention relates to a liquid crystal display device, and more particularly to a transfective liquid crystal display device.

[0004] 2. Description of Related Art

[0005] Recently, liquid crystal display (LCD) devices with light, thin, and low power consumption characteristics are used in office automation equipment and video units and the like. Such LCDs typically use a liquid crystal (LC) interposed between upper and lower substrates with an optical anisotropy. Since the LC has thin and long LC molecules, the alignment direction of the LC molecules can be controlled by applying an electric field to the LC molecules. When the alignment direction of the LC molecules is properly adjusted, the LC is aligned and light is refracted along the alignment direction of the LC molecules to display images.

[0006] In general, LCD devices are divided into transmissive LCD devices and reflective LCD devices according to whether the display device uses an internal or external light source.

[0007] A conventional transmissive LCD device includes an LCD panel and a backlight device. The incident light from the backlight is attenuated during the transmission so that the actual transmittance is only about 7%. The transmissive LCD device requires a high, initial brightness, and thus electrical power consumption by the backlight device increases. A relatively heavy battery is needed to supply a sufficient power to the backlight of such a device, and the battery can not be used for a lengthy period of time.

[0008] In order to overcome the problems described above, the reflective LCD has been developed. Since the reflective LCD device uses ambient light instead of the backlight by using a reflective opaque material as a pixel electrode, it is light and easy to carry. In addition, the power consumption of the reflective LCD device is reduced so that the reflective LCD device can be used as an electric diary or a PDA (personal digital assistant).

[0009] However, the reflective LCD device is affected by its surroundings. For example, the brightness of ambient light in an office differs largely from that of the outdoors. Therefore, the reflective LCD device can not be used where the ambient light is weak or does not exist. In order to overcome the problems described above, a transfective LCD device has been researched and developed. The trans-

fective LCD device can be transferred according to the user's selection from the transmissive mode to the reflective mode, or vice versa.

[0010] FIG. 1 is a schematic perspective view of a conventional transfective LCD device 11.

[0011] In FIG. 1, the conventional transfective LCD device 11 includes upper and lower substrates 15 and 21 with an interposed liquid crystal 23. The upper and lower substrates 15 and 21 are sometimes respectively referred to as a color filter substrate and an array substrate. On a surface facing the lower substrate 21, the upper substrate 15 includes a black matrix 16 and a color filter layer 18. The color filter layer 18 includes a matrix array of sub-color filters 17 of red (R), green (G), and blue (B) that are formed such that each color filter is bordered by the black matrix 16. The upper substrate 15 also includes a common electrode 13 over the color filter layer 18 and over the black matrix 16. On a surface facing the upper substrate 15, the lower substrate 21 includes an array of thin film transistors (TFTs) "T" that act as switching devices. The array of TFTs is formed to correspond with the matrix of color filters. A plurality of crossing gate and data lines 25 and 27 are positioned such that a TFT is located near each crossing of the gate and data lines 25 and 27. The lower substrate 21 also includes a plurality of pixel electrodes 19, each in an area defined between the gate and data lines 25 and 27. Such areas are often referred to as pixel regions "P." Each pixel electrode 19 includes a transmissive portion "A" and a reflective portion "C". The transmissive portion "A" is usually formed from a transparent conductive material having a good light transmittance, for example, indium-tin-oxide (ITO). Moreover, a conductive metallic material having a superior light reflectivity is used for the reflective portion "C".

[0012] FIG. 2 is a schematic cross-sectional view of a conventional transfective LCD device such as the device 11 of FIG. 1.

[0013] In FIG. 2, upper and lower substrates 15 and 21 are facing and spaced apart from each other and a liquid crystal layer 23 is interposed therebetween. A backlight apparatus 45 is disposed over the outer surface of the lower substrate 21. On the inner side of the upper substrate 15, a color filter layer 18 for passing only the light of a specific wavelength and a common electrode 14 functioning as one electrode for applying a voltage to the liquid crystal layer 23 are subsequently formed. On the inner surface of the lower substrate 21, a pixel electrode 32 functioning as the other electrode for applying a voltage to the liquid crystal layer 23, a passivation layer 34 having a transmissive hole 31 exposing a portion of the pixel electrode 32, and a reflective plate 36 are subsequently formed. An area corresponding to the reflective plate 36 is a reflective portion "C" and an area corresponding to the portion of the pixel electrode 32 exposed by the transmissive hole 31 is a transmissive portion "A".

[0014] A cell gap " d_1 " at the transmissive portion "A" is about twice of a cell gap " d_2 " at the reflective portion "C" to reduce the light path difference. A retardation " $\Delta n \cdot d$ " of the liquid crystal layer 23 is defined by a multiplication of refractive index anisotropy " Δn " with a cell gap " d " and the light efficiency of the LCD device is proportional to the retardation. Therefore, to reduce the difference of light efficiencies between the reflective and transmissive modes, the retardations of the liquid crystal layer 23 at two portions

should be nearly equal to each other by making the cell gap of the transmissive portion larger than that of the reflective portion.

[0015] However, even though the light efficiencies of the liquid crystal layer between the reflective and transmissive modes become equal by making the cell gaps different, the light passing the color filters at different locations is different so that the brightness can be different at the front of the display device. The transmittance of the color filter resin whose absorption coefficient is high for a specific wavelength and low for the other wavelengths has the following relation considering only the absorption, i.e., the transmittance is inversely proportional to the absorption coefficient and the distance that light passes:

$$T = \exp(-\alpha(\lambda)d)$$

[0016] where T is transmittance, $\alpha(\lambda)$ is an absorption coefficient depending on the wavelength and d is a distance that light passes.

[0017] Since the color filter resin is a viscous material, the thickness of the color filter resin is hard to control and the color filter layer can not be made less than a specific thickness. Therefore, the color filter layers of the reflective and transmissive portions have the same thickness and the different absorption coefficient (i.e., different material) for the uniform transmittance.

[0018] However, if the color filter layers of the reflective and transmissive portions are formed of different materials, the process and the cost would be increased and the yield would be decreased.

[0019] To solve the above problems, a fabricating method of the color filter layers with the same resin is suggested. In this method, the color filter layers at the reflective and transmissive portions have the same absorption coefficient but a different thickness so that the transmittance has the same value.

[0020] FIGS. 3A and 3B are transmittance spectrums of first and second red color filter layers for the reflective mode having a specific thickness and two times the specific thickness, respectively.

[0021] Generally, a visible light has a wavelength ranging about 400 to 700 nanometers. Red (R), green (G) and blue (B) colors roughly correspond to wavelengths of 650, 550 and 450 nanometers, respectively.

[0022] In FIG. 3A, the transmittances at wavelengths corresponding to R, G and B are about 97%, 20% and 58%, respectively. Even though the transmittance for red color is high, the transmittances for the other colors are also not negligible so that a satisfying color purity is not obtained.

[0023] In FIG. 3B, since the second red color filter layer has twice the thickness and square transmittance compared with the first red color filter layer of FIG. 2A, the transmittances at wavelengths corresponding to R, G and B are about 94%, 4% and 34%, respectively. Although the transmittance is decreased for all colors, the decreased amount is different for the individual colors, for example, about 5%, 16% and 24% for R, G and B, respectively.

[0024] Therefore, the color purity of the second red color filter layer is improved and this result can be applied for the green and blue color filters so that the transmittance and

color purity of the transfective LCD device using the same kind of color filter resin can be uniform for the reflective and transmissive portions.

[0025] A transfective LCD device using a dual thickness color filter (DCF) of the above-mentioned principle is suggested in Korean Patent Application No. 2001-9979 of the applicant.

[0026] FIG. 4 is a cross-sectional view of a transfective LCD device using the DCF according to a related art.

[0027] In FIG. 4, a transparent buffer layer 64 is formed on the inner surface of the upper substrate 15 only at a reflective portion "C", and a color filter layer 62 is formed on the entire upper substrate 15. Therefore, the color filter layer 62 of a transmissive portion "A" is thicker than that of the reflective portion "C" so that the color purity of the transmissive portion "A" can be improved. The transparent buffer layer 64 is formed by depositing and patterning one of an insulating material group comprising acrylic resin, benzocyclobutene (BCB) and silicon nitride (SiNx). Therefore, the buffer layer 64 of a yellowish color is not perfectly transparent and the transmittance of the buffer layer 64 is lower than that of glass substrate. Moreover, since light is partially reflected at the interface between the buffer layer 64 and the substrate 15, the transmittance at the reflective portion "C" is more decreased.

[0028] FIGS. 5A and 5B are cross-sectional views of color filter substrates using the DCF having transparent buffer layers of first and second thicknesses, respectively, according to a related art.

[0029] In FIG. 5A, the substrate 15 has a transmissive portion "A" and a reflective portion "C". A black matrix 70 and a transparent buffer layer 64 are formed in the reflective portion "C" and a color filter layer 62 is formed on the entire surface of the substrate 15. Since the transparent buffer layer 64 of a first thickness has a low step 52 at the borderline of the transmissive portion "A" and the reflective portion "C" so that the surface of the color filter layer 62 can be planarized. Moreover, since the color filter layer 62 at the transmissive portion "A" is thicker than that at the reflective portion "C", the color purity can be improved at the transmissive portion "A". However, since the thickness of the transparent buffer layer 64 has a limit for the planarization of the color filter layer 62, the thickness ratio of the color filter layer 62 also has a limit and the improvement of the color purity is limited.

[0030] In FIG. 5B, to have a desired thickness ratio of the color filter layer 62, the transparent buffer layer 64 has a second thickness higher than the first thickness of FIG. 5A and a high step 54 at the borderline of the transmissive portion "A" and the reflective portion "C". Since the color filter layer 64 is made of a viscous resin and formed according to the surface of the underlayer, the color filter layer 64 also has a step 55 at the top surface. Therefore, the difference " Δd " between the designed thickness d_3 and the fabricated thickness d_4 occurs and the improvement of the color purity of the transmissive portion "A" is limited.

[0031] Generally, the thickness of a conventional color filter layer for the reflective LCD device is controlled to have the average transmittance in the range of about 55 to 70%. If the thickness of the color filter layer is increased, the transmittance and the color appearance of the color filter

layer are varied. For the color filter layer twice as thick as the conventional color filter, the transmittance and the color appearance are 46% and 24.9%, respectively. On the other hand, for the color filter layer 1.3 times as thick as the conventional color filter, the transmittance and the color appearance are 54.7% and 14.1%, respectively. Consequently, if the color filter layer of the transmissive portion is not formed with a desired thickness, the color property of the transmissive portion can not approach that of the reflective portion.

[0032] Furthermore, since the step of the color filter layer also degrades the planarization property of the common electrode on the color filter layer, the display quality of conventional LCDs is degraded.

SUMMARY OF THE INVENTION

[0033] Accordingly, the present invention is directed to a reflective liquid crystal display device that substantially obviates one or more of the problems due to limitations and disadvantages of the related art.

[0034] An object of the present invention is to provide a color filter substrate of a reflective liquid crystal display device that has a high transmittance and color purity, and a manufacturing method of the color filter substrate.

[0035] Another object of the present invention is to provide a color filter substrate of a reflective liquid crystal display device that has a high color purity, and a manufacturing method of the color filter substrate.

[0036] Additional features and advantages of the invention will be set forth in the description which follows, and in part will be apparent from the description, or may be learned by practice of the invention. The objectives and other advantages of the invention will be realized and attained by the structure particularly pointed out in the written description and claims hereof as well as the appended drawings.

[0037] To achieve these and other advantages and in accordance with the purpose of the present invention, as embodied and broadly described, a color filter substrate for a liquid crystal display device according to an embodiment of the present invention includes: a substrate having a transmissive portion and a reflective portion, the transmissive portion having a groove; a black matrix on the substrate; and a color filter layer on the black matrix and on the substrate.

[0038] In another aspect, a method of fabricating a color filter substrate for a liquid crystal display device includes: forming a groove on a substrate, the substrate having a transmissive portion and a reflective portion, the transmissive portion having the groove; forming a black matrix on the substrate; and forming a color filter layer of a first color on the black matrix and the substrate.

[0039] In another aspect, a color filter substrate for a liquid crystal display device includes: a substrate having a transmissive portion and a reflective portion; a black matrix on the substrate; a plurality of buffer patterns at the reflective portion, the plurality of buffer patterns having a substantially uneven shape; and a color filter layer at the transmissive and reflective portions.

[0040] In another aspect, a method of fabricating a color filter substrate for a liquid crystal display device includes: forming a black matrix on a substrate, the substrate having a transmissive portion and a reflective portion; forming a plurality of buffer patterns at the transmissive portion, the plurality of buffer patterns having a substantially uneven shape; and forming a color filter layer at the transmissive and reflective portions.

[0041] It is to be understood that both the foregoing general description and the following detailed description are exemplary and explanatory and are intended to provide further explanation of the invention as claimed.

BRIEF DESCRIPTION OF THE DRAWINGS

[0042] The present invention will become more fully understood from the detailed description given hereinbelow and the accompanying drawings which are given by way of illustration only, and thus do not limit the present invention.

[0043] In the drawings:

[0044] FIG. 1 is a schematic perspective view of a conventional transreflective LCD device;

[0045] FIG. 2 is a schematic cross-sectional view of a conventional transreflective LCD device;

[0046] FIGS. 3A and 3B are transmittance spectrums of first and second red color filter layers for the reflective mode having a specific thickness and twice of the specific thickness, respectively, according to a related art;

[0047] FIG. 4 is a cross-sectional view of a transreflective LCD device using DCF;

[0048] FIGS. 5A and 5B are cross-sectional views of color filter substrates using DCF having transparent buffer layers of first and second thicknesses, respectively, according to a related art;

[0049] FIGS. 6A to 6C are schematic cross-sectional views of a color filter substrate illustrating a fabricating process according to a first embodiment of the present invention;

[0050] FIG. 7 is a schematic cross-sectional view of a color filter substrate according to a second embodiment of the present invention;

[0051] FIGS. 8A to 8C are schematic cross-sectional views of a color filter substrate illustrating a fabricating process according to a third embodiment of the present invention;

[0052] FIG. 9 is a schematic cross-sectional view of a color filter substrate according to a fourth embodiment of the present invention;

[0053] FIGS. 10A to 10D are schematic cross-sectional views of a color filter substrate illustrating a fabricating process according to a fifth embodiment of the present invention;

[0054] FIG. 11 is a schematic cross-sectional view of a color filter substrate illustrating the principle of the present invention;

[0055] FIGS. 12A to 12F are schematic plan views of a plurality of buffer patterns according to several embodiments of the present invention;

[0056] FIGS. 13A to 13C are schematic cross-sectional views of a color filter substrate illustrating a fabricating process according to a sixth embodiment of the present invention;

[0057] FIG. 14 is a schematic cross-sectional view of a color filter substrate according to a seventh embodiment of the present invention;

[0058] FIGS. 15A to 15D are schematic cross-sectional views of a color filter substrate illustrating a fabricating process according to an eighth embodiment of the present invention; and

[0059] FIG. 16 is a cross-sectional view of a color filter substrate according to a ninth embodiment of the present invention.

DETAILED DESCRIPTION OF PREFERRED EMBODIMENTS

[0060] Reference will now be made in detail to the preferred embodiments of the present invention, example of which is illustrated in the accompanying drawing.

[0061] FIGS. 6A to 6C are schematic cross-sectional views of a color filter substrate illustrating a fabricating process thereof according to a first embodiment of the present invention. The color filter substrate is usable in any type of an LCD device or other display device. In FIGS. 6A to 6C, the substrate 112 has a transmissive portion "A" and a reflective portion "C".

[0062] In FIG. 6A, a groove 114 is formed at the transmissive portion "A" of the LCD device by photolithography and etching processes, or other techniques. The depth d_5 from the top surface of an upper substrate 112 is determined considering the thickness ratio of the color filter layer between the transmissive and reflective portions "A" and "C". Preferably, this thickness ratio may be 1:2.

[0063] In FIG. 6B, a black matrix 116 is formed on the substrate 112 by depositing and patterning a black resin or an opaque metallic material.

[0064] In FIG. 6C, a color filter layer 118 of a first color is formed over the substrate 112 and a portion of the black matrix 116 by depositing and patterning a color resin. By repeating this process for second and third colors, a color filter layer of three colors can be selectively formed on the substrate 112. The step height " Δd " of the color filter layer 118 is within a range of about 0.1 to a few micrometers.

[0065] FIG. 7 a schematic cross-sectional view of a color filter substrate according to a second embodiment of the present invention.

[0066] In FIG. 7, the color filter substrate is identical to that in the first embodiment, except that a black matrix 116 is formed on a color filter layer 118 and the dimensions of the color filter substrate may vary as needed.

[0067] In the case of a transparent plastic substrate, a groove can be formed by a molding process during a fabricating process of the substrate and the molding process is more suitable to the control of the depth than the etching process.

[0068] FIGS. 8A to 8C are schematic cross-sectional views of a color filter substrate for an LCD device illustrat-

ing a fabricating process thereof according to a third embodiment of the present invention.

[0069] In FIG. 8A, a substrate 120 is made of transparent plastic so that a groove 114 can be formed at a transmissive portion of the LCD by a molding process during a fabricating process of the substrate 120. The use of a transparent material allows an easy control over the profile of the groove 114.

[0070] In FIG. 8B, a black matrix 116 is then formed selectively on the substrate 112 by depositing and patterning a black resin, an opaque metallic material, or the like.

[0071] In FIG. 8C, a color filter layer 118 of a first color is formed on the substrate 120 and portions of the black matrix 116 by depositing and patterning a color resin. By repeating this process for second and third colors, a color filter layer of three colors can be selectively formed on the substrate 120. This completes the process of forming the color filter substrate according to this embodiment.

[0072] FIG. 9 is a schematic cross-sectional view of a color filter substrate for an LCD device according to a fourth embodiment of the present invention.

[0073] In FIG. 9, the color filter substrate is identical to that of the third embodiment, except that a black matrix 116 is formed on a color filter layer 118 and the dimensions of the color filter substrate may vary as needed.

[0074] FIGS. 10A to 10D are schematic cross-sectional views except that of a color filter substrate for an LCD device illustrating a fabricating process thereof according to a fifth embodiment of the present invention. In this embodiment as shown FIGS. 10A to 10D, the substrate 112 has a transmissive portion "A" and a reflective portion "C".

[0075] In FIG. 10A, after depositing an opaque metallic material on the substrate 112, an opaque metal pattern 115 is formed by selectively removing the deposited opaque metallic material in the transmissive portion "A".

[0076] In FIG. 10B, a groove 114 is then formed at the transmissive portion "A" by selectively etching the substrate 112 in the transmissive portion "A" as the opaque metal pattern 115 is used as a mask for this etching process.

[0077] In FIG. 10C, a black matrix 116 is then formed by selectively etching the opaque metal pattern 115.

[0078] In FIG 10D, a color filter layer 118 of a first color is formed by depositing and patterning a color resin on the substrate 112 and the black matrix 116. By repeating this process for second and third colors, a color filter layer of three colors can be formed selectively on the substrate 112.

[0079] In the first to fifth embodiments, since the groove of the transmissive portion is formed by etching the substrate itself, a separate buffer layer is not necessary and thus, the production cost of the color filter substrate can be reduced. If the substrate of transparent plastic is used, the etching process for the groove is also unnecessary due to the molding process, which further reduces the production cost. Moreover, since the buffer layer is not used, the substrate of the reflective portion does not have an interface between the buffer layer and the substrate so that the reflection from the interface can not occur and the device performance is improved.

[0080] However, since the color filter layer has a step at its top surface, the thickness ratio of the color filter layer between the transmissive and reflective portions has a limit so that the improvement of color property can be somewhat limited. Therefore, a method is provided in the present invention for obtaining a desired thickness ratio and minimizing the step at the top surface of the color filter layer. This method employs a plurality of buffer patterns as discussed below.

[0081] FIG. 1 is a schematic cross-sectional view of a color filter substrate illustrating the principle of the present invention.

[0082] In FIG. 11, a substrate 112 has a transmissive portion "A" and a reflective portion "C" and a plurality of buffer patterns 117 having a substantially uneven shape are formed at the reflective portion "C". The shape of the buffer patterns 117 can be any shape. Since the plurality of buffer patterns 117 have a lot of fine grooves, the thickness " d_6 " of color filter layer of the reflective portion "C" can be reduced or minimized so that the thickness ratio ($d_6:d_7$) of the color filter layer between the transmissive and reflective portions "A" and "C" can be increased. Therefore, the color difference between the transmissive and reflective portions "A" and "C" can be further reduced.

[0083] FIGS. 12A to 12F are schematic top plan views of a plurality of buffer patterns usable in a color filter substrate according to several embodiments of the present invention. In FIGS. 12A to 12F, a hatched region means an etched region, i.e., a concave region and a white region means a buffer pattern, i.e., a convex region.

[0084] As shown in FIGS. 12A and 12B, a buffer pattern having a plurality of circular concave holes 124, and a plurality of circular convex buffer patterns 125 are provided.

[0085] In FIGS. 12C and 12D, a buffer pattern having a plurality of concave holes 126 and convex buffer patterns 127 have a rectangular shape.

[0086] In FIGS. 12E and 12F, a plurality of buffer patterns 128 and 129 are formed along the direction of columns and rows, respectively.

[0087] FIGS. 13A to 13C are schematic cross-sectional views of a color filter substrate illustrating a fabricating process thereof according to a sixth embodiment of the present invention.

[0088] In FIG. 13A, a black matrix 116 is formed on a substrate 112. The black matrix 116 has a structure of a single layer of chromium (Cr) or a double layer of chromium (Cr) and chromium oxide (CrOx).

[0089] In FIG. 13B, a plurality of buffer patterns 117 covering the black matrix 116 are formed only at the reflective portion "C" by depositing and etching a transparent material such as benzocyclobutene (BCB), acrylic resin, or silicon nitride (SiNx). The plurality of buffer patterns 117 have a substantially uneven shape, e.g., fine grooves 142 between projections.

[0090] In FIG. 13C, a color filter layer 118 is formed on the plurality of buffer patterns 117. Even though the color filter layer 118 is not planarized, a reduced step 155 is produced due to the fine grooves 142 between the plurality of buffer patterns. Here, the height " d_8 " of the bottom of the

grooves 142 equals the height " d_9 " of the surface of the substrate 112 at the transmissive portion "A". By repeating this process for three color filters, a full color filter layer of three colors can be formed.

[0091] FIG. 14 is a schematic cross-sectional view of a color filter substrate according to a seventh embodiment of the present invention.

[0092] In FIG. 14, the color filter substrate is identical to that shown in FIG. 13C, except that the height " d_{10} " from the bottom surface of grooves 144 to the bottom surface of the substrate 112 is larger than the height " d_{11} " of the substrate 112 at the transmissive portion "A". In this structure, since the plurality of buffer patterns 117 can be lowered, a surface step 156 of the color filter layer 118 can be further reduced.

[0093] FIGS. 15A to 15D are schematic cross-sectional views of a color filter substrate illustrating a fabricating process thereof according to an eighth embodiment of the present invention.

[0094] As shown in FIG. 15A, in this embodiment of the color filter substrate, a substrate 200 has a transmissive portion "A" and a reflective portion "C". An opaque metal pattern 204 is formed selectively on the substrate 200 only at the reflective portion "C".

[0095] In FIG. 15B, a plurality of buffer patterns 206 are formed by selectively etching the substrate 200 while the opaque metal pattern 204 is used as a mask. In this etching process, the substrate 200 under the opaque metal pattern 204 is not etched to become a convex portion of the plurality of buffer patterns 206. Also, a portion of the substrate 200 in the transmissive portion "A" is removed to provide a groove 250.

[0096] In FIG. 15C, a black matrix 208 is then formed by further etching the opaque metal pattern 204.

[0097] In FIG. 15D, a color filter layer 210 is formed over the substrate 200. Even though the color filter layer 210 has a surface step 255 between the transmissive and reflective portions "A" and "C", the surface step 255 is reduced due to the plurality of buffer patterns 206.

[0098] FIG. 16 is a cross-sectional view of a color filter substrate according to a ninth embodiment of the present invention.

[0099] As shown in FIG. 16, the color filter substrate is identical to that shown in FIG. 15D, except that the height " d_{12} " from the bottom surface of the plurality of buffer patterns 206 to the bottom surface of the substrate 200 is bigger than the height " d_{13} " of the substrate 200 at the transmissive portion "A". The ninth embodiment can be acquired by adding an etching process for the transmissive portion "A" to the process of the eighth embodiment shown in FIGS. 15A to 15D. In the ninth embodiment structure, since the plurality of buffer patterns 206 can be lowered, a surface step 256 of the color filter layer 210 is further reduced so that the color purity of the display device can be further improved.

[0100] The plurality of buffer patterns according to the embodiments of the present invention can have a uniform pitch in the range of about 14 to 45 micrometers.

[0101] The present invention is not limited to LCD devices, but is applicable to other types of display devices and apparatuses.

[0102] It will be apparent to those skilled in the art that various modifications and variation can be made in the method of manufacturing a flat pane display device of the present invention without departing from the spirit or scope of the invention. Thus, it is intended that the present invention cover the modifications and variations of this invention provided they come within the scope of the appended claims and their equivalents.

What is claimed is:

1. A color filter substrate for a display device, comprising:
 - a base substrate having a transmissive portion and a reflective portion, the transmissive portion having a groove;
 - a color filter layer on the base substrate; and
 - a black matrix on the color filter layer.
2. A method of fabricating a color filter substrate for a display device, comprising:
 - forming an opaque metal pattern on a base substrate, the base substrate having a transmissive portion and a reflective portion, the opaque metal pattern being formed at the reflective portion;
 - forming a groove at the transmissive portion by selectively removing the base substrate using the opaque metal pattern as a mask;
 - forming a black matrix on the base substrate by selectively removing the opaque metal pattern; and
 - forming a color filter layer of a first color on the black matrix and on the base substrate.
3. The method according to claim 2, further comprising:
 - forming color filter layers of second and third colors on the black matrix and on the base substrate.
4. A color filter substrate for a display device, comprising:
 - a base substrate having a transmissive portion and a reflective portion;
 - a black matrix on the base substrate;
 - a plurality of buffer patterns at the reflective portion, the plurality of buffer patterns having a substantially uneven shape; and
 - a color filter layer at the transmissive and reflective portions.
5. The color filter substrate according to claim 4, wherein the color filter layer at the transmissive portion is thicker than that at the reflective portion.
6. The color filter substrate according to claim 4, wherein the plurality of buffer patterns are formed by selectively removing the base substrate.
7. The color filter substrate according to claim 6, wherein the base substrate is made of glass.
8. The color filter substrate according to claim 4, wherein the plurality of buffer patterns are formed by depositing and selectively removing a transparent material.
9. The color filter substrate according to claim 8, wherein the plurality of buffer patterns are formed of one of benzocyclobutene, acrylic resin and silicon nitride.

10. The color filter substrate according to claim 4, wherein the plurality of buffer patterns have a uniform pitch.

11. The color filter substrate according to claim 10, wherein the pitch is within a range of about 14 to 45 micrometers.

12. The color filter substrate according to claim 4, wherein a bottom surface of the plurality of the buffer patterns is located higher than a top surface of the transmissive portion of the base substrate.

13. A method of fabricating a color filter substrate for a liquid crystal display device, comprising:

- forming a black matrix on a base substrate, the base substrate having a transmissive portion and a reflective portion;

- forming a plurality of buffer patterns at the transmissive portion, the plurality of buffer patterns having a substantially uneven shape; and

- forming a color filter layer at the transmissive and reflective portions.

14. The method according to claim 13, wherein the plurality of buffer patterns have a uniform pitch.

15. The method according to claim 14, wherein the pitch is within a range of about 14 to 45 micrometers.

16. The method according to claim 13, wherein a bottom surface of the plurality of the buffer patterns is located higher than a top surface of the transmissive portion of the base substrate.

17. The method according to claim 13, wherein the plurality of buffer patterns are formed by depositing and selectively removing a transparent material.

18. The method according to claim 17, wherein the plurality of buffer patterns are formed of one of benzocyclobutene, acrylic resin and silicon nitride.

19. A method of fabricating a color filter substrate for a display device, comprising:

- forming a plurality of buffer patterns by selectively etching a base substrate, the base substrate having a transmissive portion and a reflective portion, the plurality of buffer patterns being formed at the reflective portion and having a substantially uneven shape;

- forming a black matrix on the plurality of the buffer patterns; and

- forming a color filter layer at the transmissive and reflective portions.

20. The method according to claim 19, wherein the plurality of buffer patterns have a uniform pitch.

21. The method according to claim 20, wherein the pitch is within a range of about 14 to 45 micrometers.

22. The method according to claim 19, further comprising:

- forming an opaque metal pattern on the base substrate.

23. The method according to claim 19, wherein the base substrate is made of glass.

24. The method according to claim 19, wherein a bottom surface of the plurality of the buffer patterns is located higher than a top surface of the transmissive portion of the base substrate.

25. The method according to claim 24, further comprising:

etching only the transmissive portion of the base substrate.

26. A method of fabricating a color filter substrate for a display device, comprising:

forming an opaque metal pattern on a base substrate, the base substrate having a transmissive portion and a reflective portion, the opaque metal pattern being formed at the reflective portion;

forming a plurality of buffer patterns at the reflective portion by selectively removing the base substrate using the opaque metal pattern as a mask;

forming a black matrix on the base substrate by selectively removing the opaque metal pattern; and

forming a color filter layer at the transmissive and reflective portions.

* * * * *

专利名称(译)	具有滤色器的半透半反液晶显示装置及其制造方法		
公开(公告)号	US20050046769A1	公开(公告)日	2005-03-03
申请号	US10/952780	申请日	2004-09-30
[标]申请(专利权)人(译)	乐金显示有限公司		
申请(专利权)人(译)	LG.飞利浦液晶CO., LTD.		
当前申请(专利权)人(译)	LG DISPLAY CO., LTD.		
[标]发明人	YI JOOG HOO KWON OH NAM HA KYOUNG SU		
发明人	YI, JOOG-HOO KWON, OH NAM HA, KYOUNG-SU		
IPC分类号	G02F1/1333 G02F1/1335		
CPC分类号	G02F1/1333 G02F1/133512 G02F1/133555 G02F1/133516 G02F1/133514		
优先权	1020010004937 2001-02-01 KR 1020010005044 2001-02-02 KR		
其他公开文献	US7265808		
外部链接	Espacenet USPTO		

摘要(译)

提供一种用于液晶显示装置的滤色器基板和制造该滤色器基板的方法。滤色器基板包括具有透射部分和反射部分的基础基板，透射部分具有凹槽，在基础基板上的滤色器层，以及在滤色器层上的黑色矩阵。

