



(19) **United States**

(12) **Patent Application Publication**
Bu et al.

(10) **Pub. No.: US 2004/0155849 A1**

(43) **Pub. Date: Aug. 12, 2004**

(54) **DATA DRIVER FOR AN LCD PANEL**

Publication Classification

(76) Inventors: **Lin-Kai Bu**, Shanhua Township (TW);
Chuan-Cheng Hsiao, Shanhua
Township (TW); **Yen-Chen Chen**,
Shanhua Township (TW)

(51) **Int. Cl.⁷** G09G 3/36

(52) **U.S. Cl.** 345/98

(57) **ABSTRACT**

Correspondence Address:
**THOMAS, KAYDEN, HORSTEMEYER &
RISLEY, LLP**
100 GALLERIA PARKWAY, NW
STE 1750
ATLANTA, GA 30339-5948 (US)

A data driver for driving multiple data lines on an LCD panel according to multiple channels of pixel data. In the data driver, a digital buffer receives and stores the pixel data at several times and selectively outputs a channel of the pixel data at a time. A DAC receives the pixel data output from the digital buffer at several times, converts the pixel data into multiple channels of analog pixel data and outputs the analog pixel data at several times. An analog buffer receives the analog pixel data output from the DAC at several times and outputs the analog pixel data at a time. An output buffer receives the analog pixel data output from the analog buffer so as to drive the data lines.

(21) Appl. No.: **10/668,983**

(22) Filed: **Sep. 22, 2003**

(30) **Foreign Application Priority Data**

Feb. 10, 2003 (TW)..... 092102692

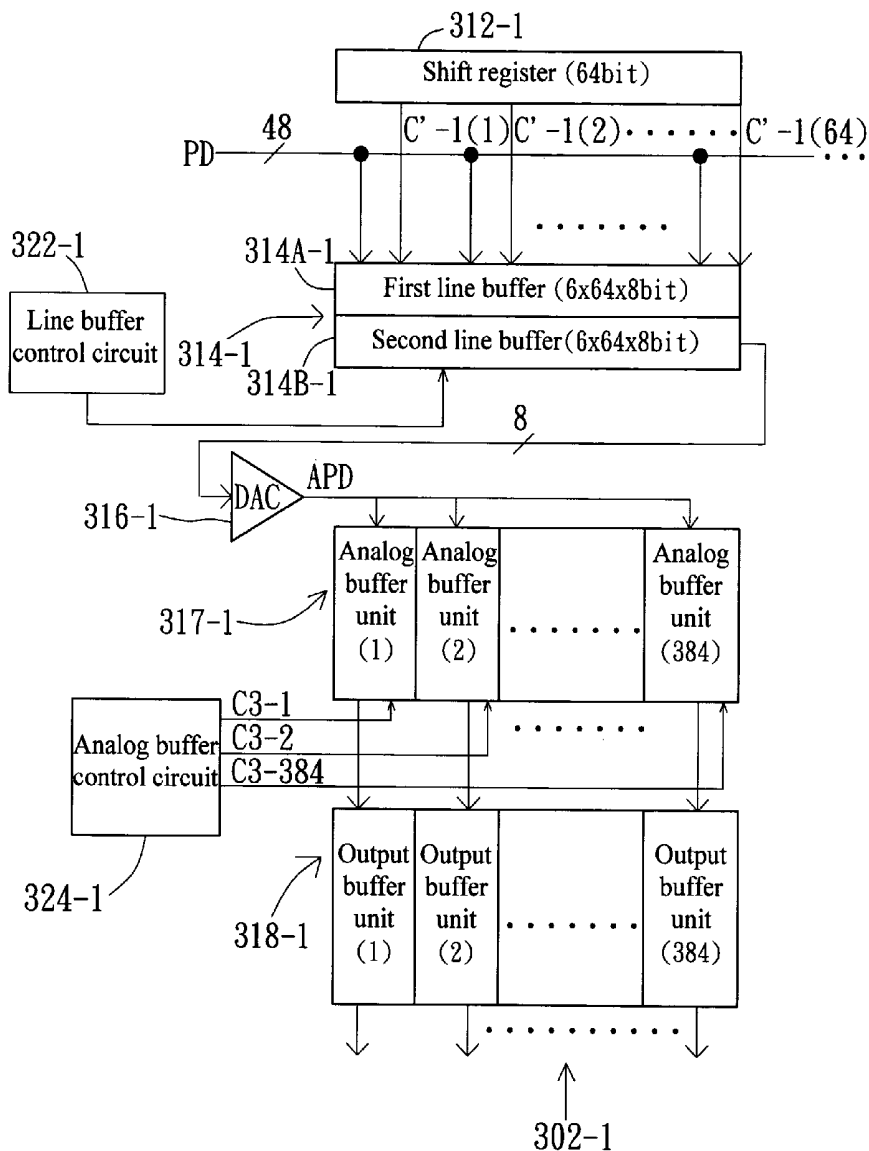

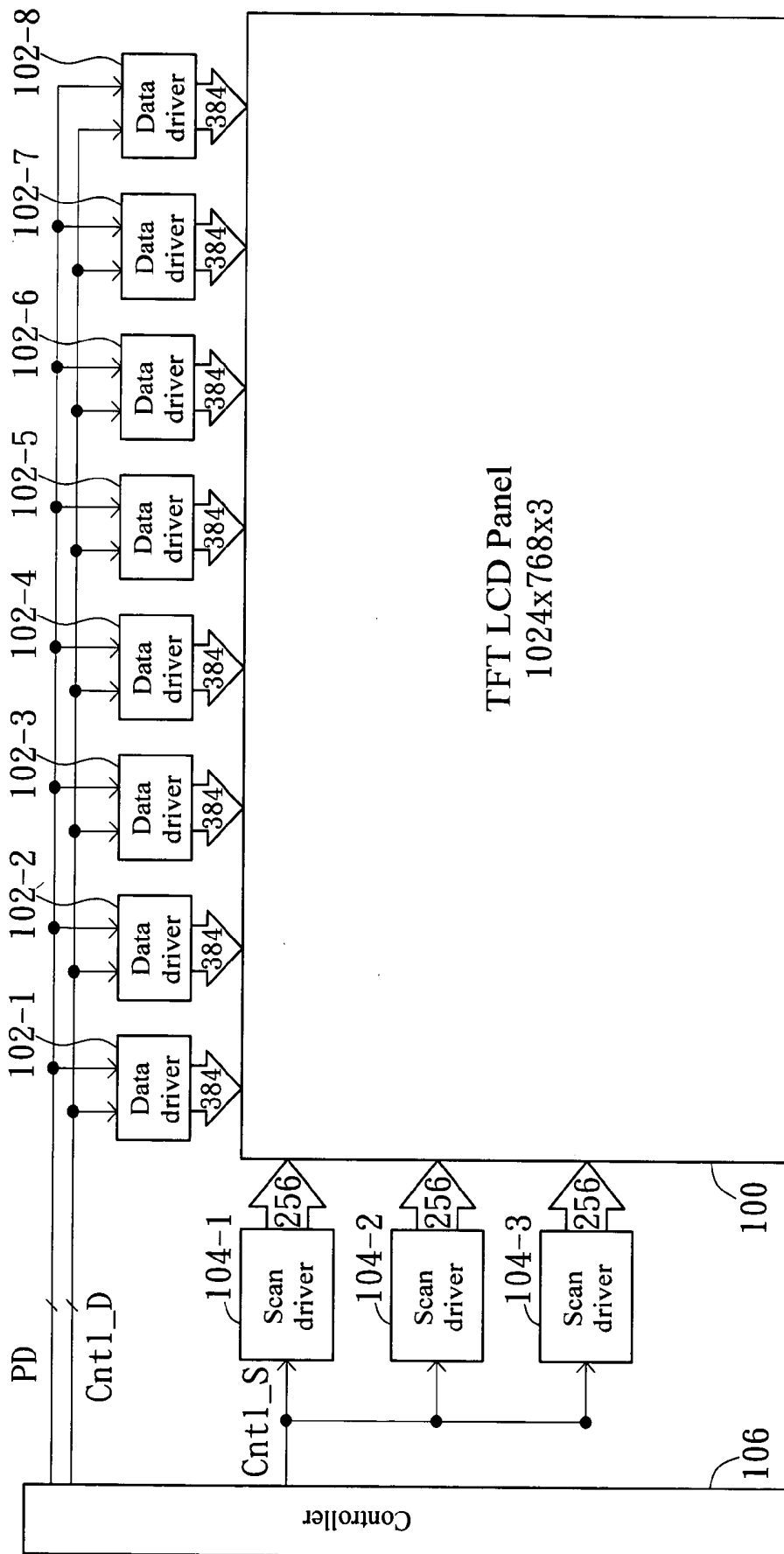

FIG. 1(PRIOR ART)

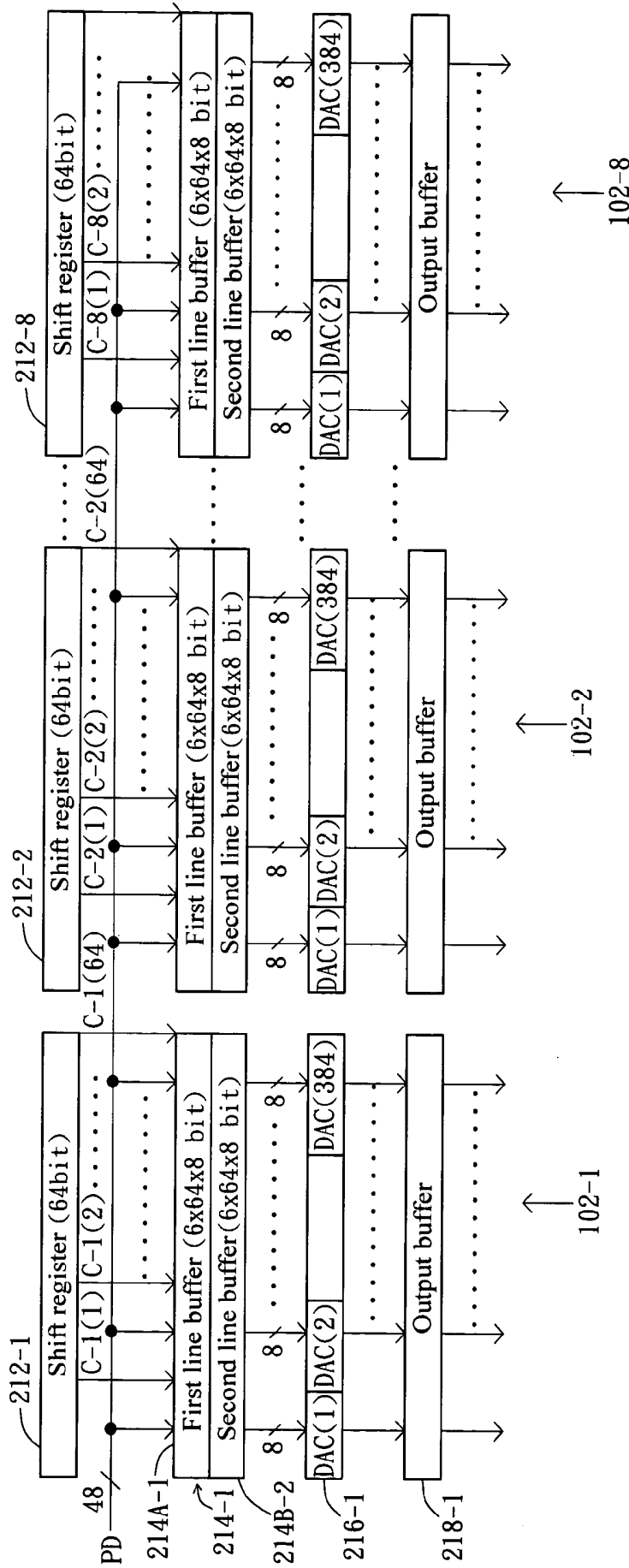

FIG. 2(PRIOR ART)

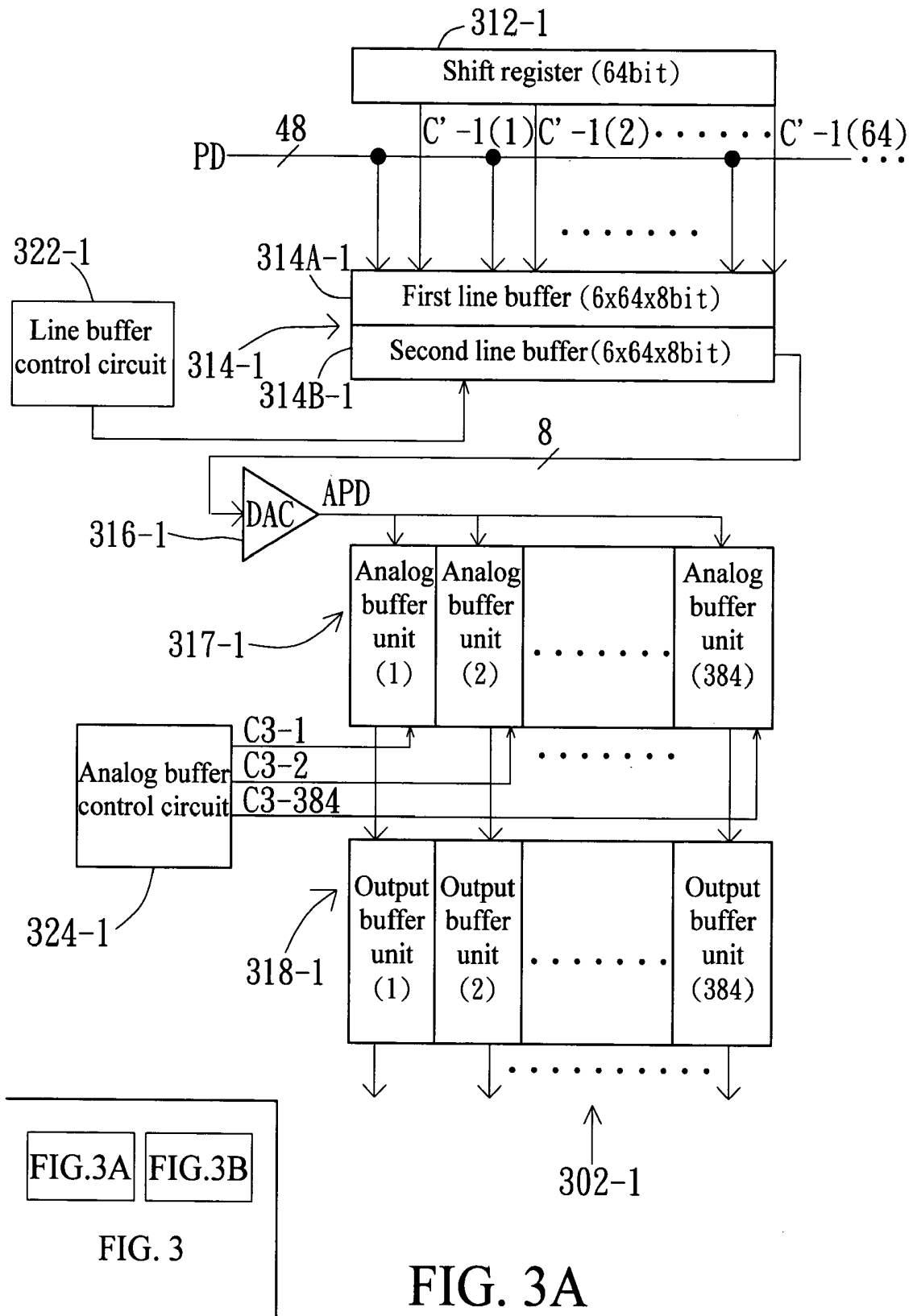

FIG.3A FIG.3B

FIG. 3

FIG. 3A

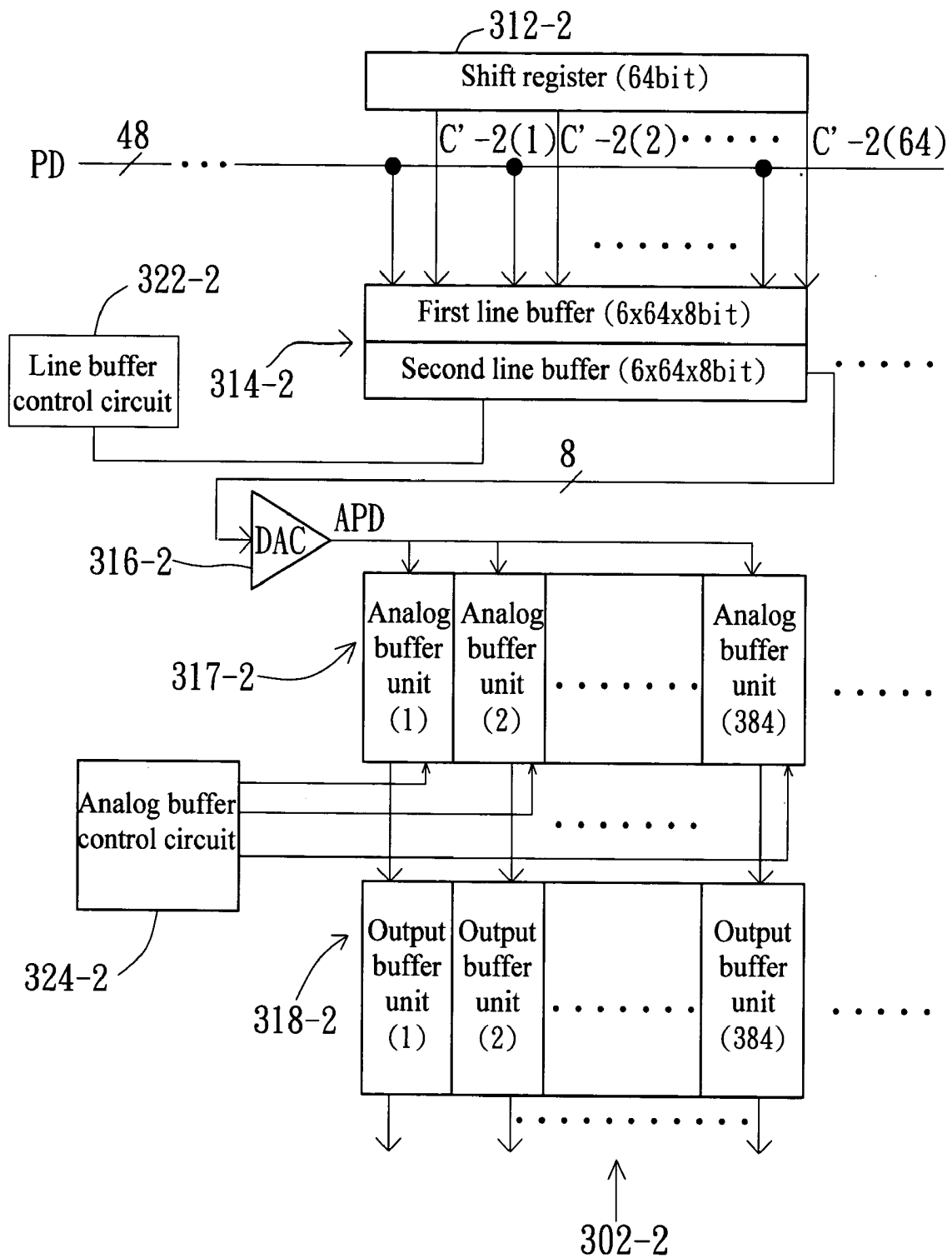

FIG. 3B

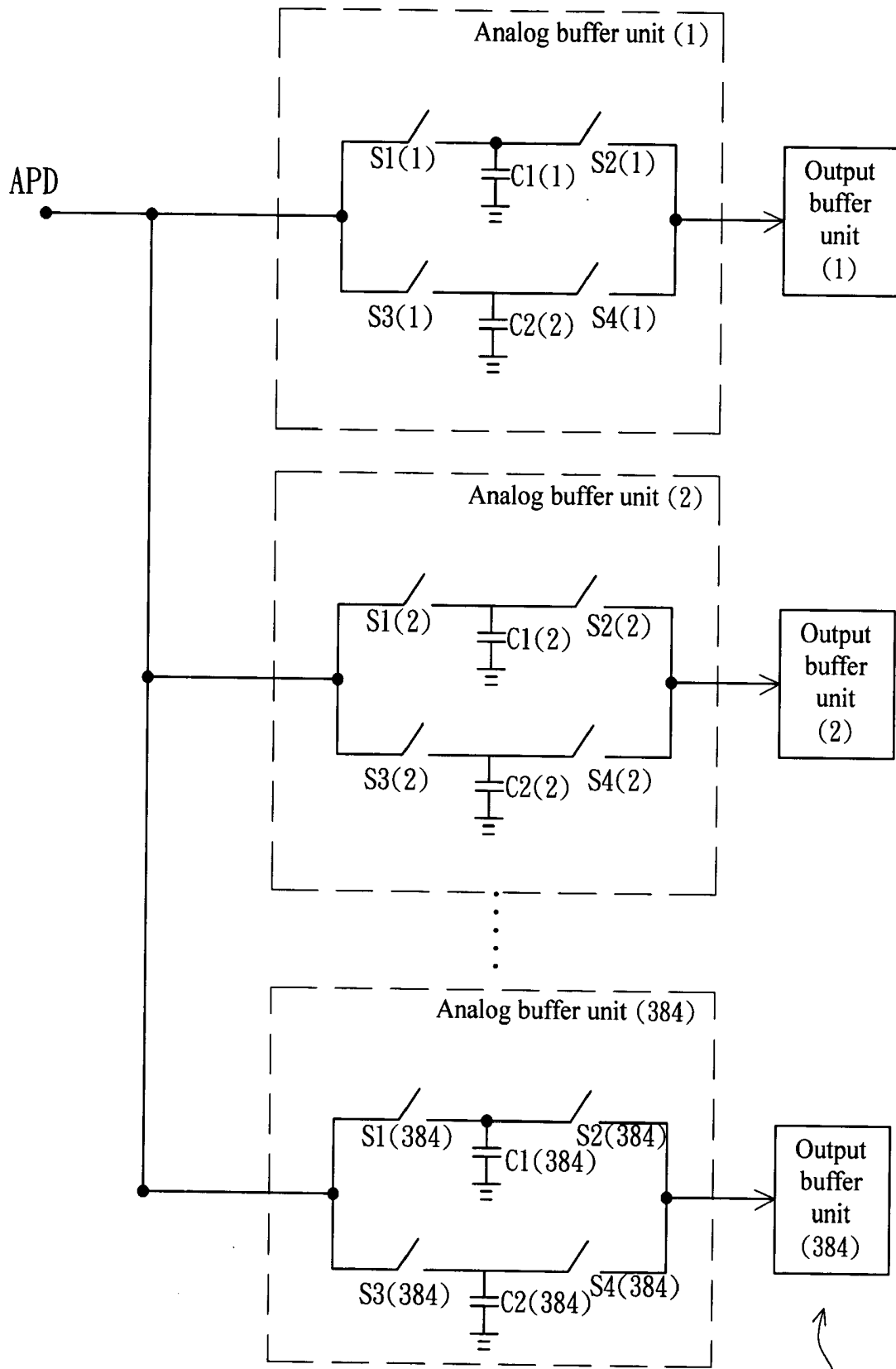

FIG. 4

317

318

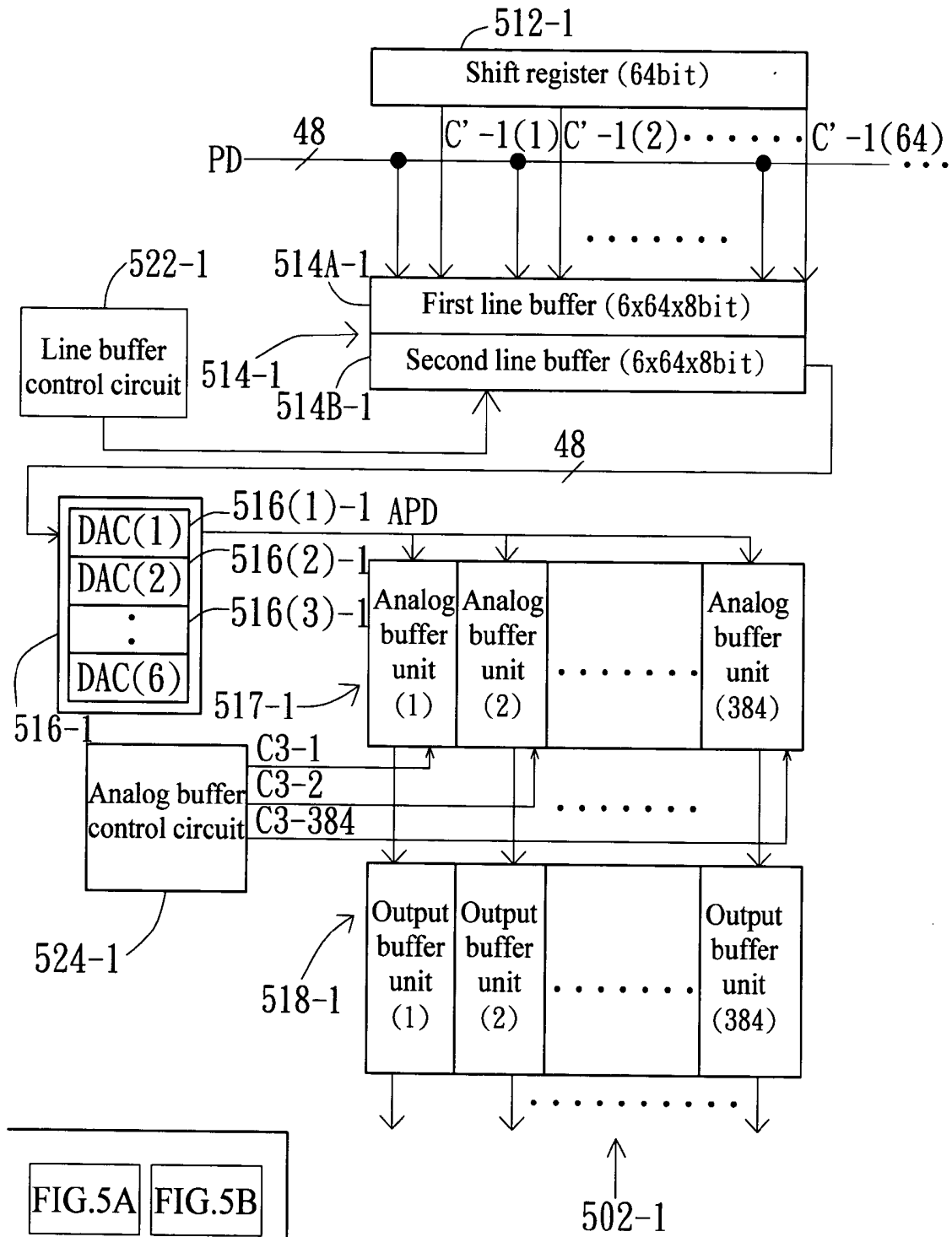

FIG. 5

FIG. 5A

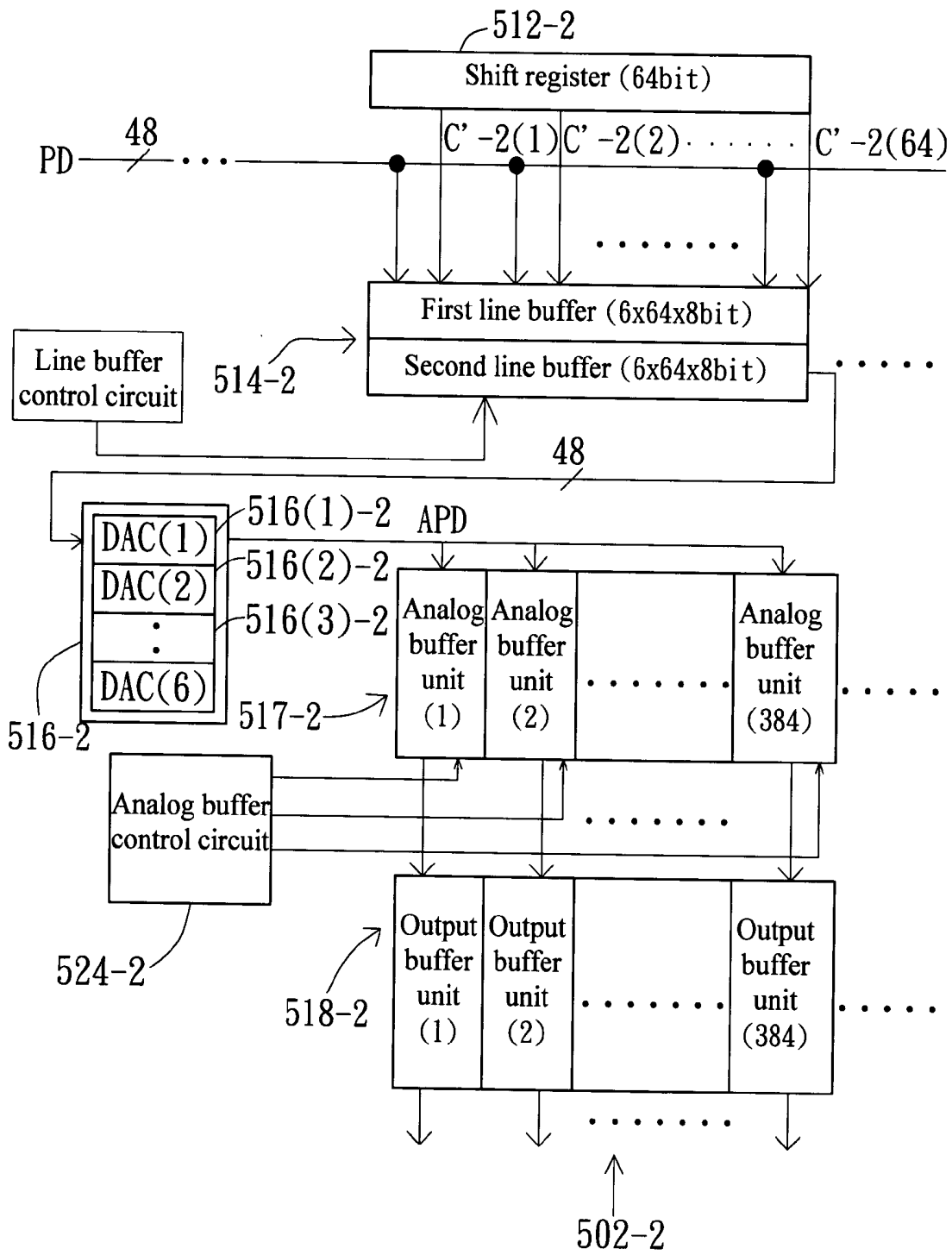

FIG. 5B

DATA DRIVER FOR AN LCD PANEL

[0001] This application claims the benefits of Taiwan application Serial No. 92102692, filed Feb. 10, 2003.

BACKGROUND OF THE INVENTION

[0002] 1. Field of the Invention

[0003] The invention relates to a data driver for an LCD (Liquid Crystal Display) panel, and more particularly to a data driver capable of saving the number of DACs (digital-to-analog converters).

[0004] 2. Description of the Related Art

[0005] Recently, LCDs have been widely used because they have favorable advantages of thinness, lightness and low electromagnetic radiation. It is therefore an important subject in the LCD field to decrease the costs of the LCDs and to increase the product competitiveness.

[0006] FIG. 1 is an architecture diagram showing a conventional LCD system. The LCD panel 100 with a resolution of 1024×768 will be described as an example. The LCD panel 100 has 1024×3 data lines that are respectively driven by data drivers 102, and 768 scan lines that are respectively driven by scan drivers 104. If each data driver 102 may drive 384 data lines and each scan driver 104 may drive 256 data lines, the LCD panel 100 requires eight data drivers 102 and three scan drivers 104. The data drivers 102-1 to 102-8 sequentially receive multiple channels of pixel data PD from a controller 106 under the control of a data control signal Cntl_D output from the controller 106. The data drivers 102-1 to 102-8 process the received pixel data PD and then drive multiple data lines of the LCD panel 100. On the other hand, the scan drivers 104 sequentially output scan signals to scan each scan line under the control of a scan control signal Cntl_S output from the controller 106.

[0007] FIG. 2 is a circuit block diagram showing the data drivers 102-1 to 102-8 of FIG. 1. The conventional data driver 102 is composed of a shift register 212, a first line buffer 214A, a second line buffer 214B, a digital-to-analog converting circuit 216, and an output buffer 218. The shift register 212 outputs a control signal C. The first line buffer 214A sequentially receives and stores the pixel data PD output from the controller 106 according to the control signal C. After the first line buffer 214A finishes its receiving operations, the first line buffer 214A simultaneously transfers all the pixel data PD stored therein to the second line buffer 214B. The second line buffer 214B simultaneously outputs all the pixel data PD to the digital-to-analog converting circuit 216. The output buffer 218 parallelly receives the pixel data PD output from the digital-to-analog converting circuit 216 and also parallelly outputs the pixel data PD to the data lines of the LCD panel 100.

[0008] The operations of the data drivers 102-1 to 102-8 as shown in FIG. 2 will be further described with reference to an example of the data driver 102-1. It is assumed that the controller 106 outputs two ports of pixel data PD to the line buffer 214-1 at a time, wherein each port of pixel data

includes a channel of red pixel data, a channel of blue pixel data, and a channel of green pixel data. That is, the controller 106 outputs six channels of pixel data PD to the line buffer 214-1 at a time. If each channel of pixel data has 8 bits, each of the first line buffer 214A and the second line buffer 214B must have 384×8 bits (i.e., 6×64×8 bits) because the data driver 102-1 has to drive 384 data lines. The controller 106 has to output 6×8 bits of six channels of pixel data at a time. After 64 times of outputs, the pixel data input operations for one data driver 102-1 are completed. After the pixel data receiving operations for one data driver 102 are finished, the pixel data receiving operations for another data driver 102 are started.

[0009] After the pixel data receiving operations for the first line buffer 214A-1 are finished, the first line buffer 214A-1 parallelly and simultaneously transfers the stored 6×64×8 bits of pixel data PD to the second line buffer 214B-1. Then, the second line buffer 214B-1 simultaneously outputs the pixel data PD to the digital-to-analog converting circuit 216-1. The digital-to-analog converting circuit 216-1 includes 384 DACs (digital-to-analog converters), that is, DAC(1) to DAC(384). Each DAC may convert one channel of pixel data PD. Thus, the digital-to-analog converting circuit 216-1 may simultaneously convert 384 channels (i.e., 6×64×8 bits) of pixel data PD into analog data.

[0010] After the digital-to-analog converting circuit 216-1 simultaneously converts the 6×64×8 bits of pixel data PD into the analog data, the digital-to-analog converting circuit 216-1 simultaneously and parallelly inputs the 384 channels of analog pixel data PD to the output buffer 218-1. The output buffer 218-1 is composed of multiple OP amplifiers, which may enhance the capability of the 384 channels of analog pixel data PD output from the data driver 102-1 for driving the data lines.

[0011] In a general circuit layout, the DACs occupy relatively large area. In each of the conventional data driver 102, because 384 channels of data pixel PD have to be converted into analog data, 384 DACs are required. Consequently, the chip area of the overall data drivers 102 is relatively large and the cost thereof is relatively high. Therefore, it is very important to reduce the area required by the DACs and to reduce the cost.

SUMMARY OF THE INVENTION

[0012] It is therefore an objective of the invention to provide a data driver capable of effectively reducing the chip area occupied by the DAC and thus the cost.

[0013] The invention achieves the above-identified objective by providing a data driver for driving multiple data lines on an LCD panel according to multiple channels of pixel data. The data driver includes a digital buffer, a DAC, an analog buffer, and an output buffer. The digital buffer receives and stores the pixel data at several times and selectively outputs a channel of the pixel data at a time. The DAC receives the pixel data output from the digital buffer at several times, converts the pixel data into multiple channels

of analog pixel data and outputs the analog pixel data at several times. The analog buffer receives the analog pixel data output from the DAC at several times and outputs the analog pixel data at a time. The output buffer receives the analog pixel data output from the analog buffer so as to drive the data lines.

[0014] The invention also achieves the above-identified objective by providing a data driver for driving multiple data lines on an LCD panel according to multiple channels of pixel data. The data driver includes a digital buffer, N sets of DACs, an analog buffer, and an output buffer. The digital buffer receives and stores the pixel data at several times and selectively outputting N channels of the pixel data at a time, wherein N is a positive integer greater than 1 and smaller than the number of the data lines. The DACs receive the pixel data output from the digital buffer, simultaneously convert N channels of the pixel data into N channel of analog pixel data, and output the analog pixel data. The analog buffer receives the analog pixel data output from the DACs at several times and outputs the analog pixel data at a time. The output buffer receives the analog pixel data output from the analog buffer so as to drive the data lines.

[0015] Other objects, features, and advantages of the invention will become apparent from the following detailed description of the preferred but non-limiting embodiments. The following description is made with reference to the accompanying drawings.

BRIEF DESCRIPTION OF THE DRAWINGS

[0016] FIG. 1 is an architecture diagram showing a conventional LCD system.

[0017] FIG. 2 is a circuit block diagram showing the data drivers 102-1 to 102-8 of FIG. 1.

[0018] FIG. 3 is a circuit block diagram showing multiple data drivers according to a first embodiment of the invention.

[0019] FIG. 4 is a circuit diagram showing internal details of the analog buffer in FIG. 3.

[0020] FIG. 5 is a circuit block diagram showing multiple data drivers according to a second embodiment of the invention.

DETAILED DESCRIPTION OF THE INVENTION

[0021] The spirit of the invention resides in that one or multiple DACs are utilized in each data driver and one or multiple channels of pixel data are input to the DACs at a time for digital-to-analog conversion, thereby saving the chip area of the data driver.

[0022] FIG. 3 is a circuit block diagram showing multiple data drivers according to a first embodiment of the invention. An LCD panel requires multiple data drivers to drive data lines. As shown in FIG. 3, eight data drivers are disclosed as an example. Each data driver 302 includes a shift register 312, a digital buffer 314, a DAC (digital-to-analog converter) 316, an analog buffer 317, and an output buffer 318. The shift register 312 outputs a first control

signal C' to the digital buffer 314. The digital buffer 314 sequentially receives and stores the pixel data PD according to the first control signal C'. The digital buffer 314 selectively outputs the pixel data PD at several times. The digital buffer 314 outputs a channel of pixel data PD to the DAC 316 at a time. The DAC 316 receives the pixel data PD output from the digital buffer 314 and then converts the pixel data PD into analog pixel data APD. The analog buffer 317 receives and stores the analog pixel data APD output from the DAC 316 and then outputs the stored analog pixel data APD at a time. The output buffer 318 receives the analog pixel data APD output from the analog buffer 317 so as to drive the data lines.

[0023] The digital buffer 314 may be composed of a first line buffer 314A and a second line buffer 314B. The first line buffer 314A sequentially receives and stores the pixel data PD according to the control signal C'. After the first line buffer 314A finishes its receiving operations, the first line buffer 314A parallelly and simultaneously transfers the pixel data PD of the first line buffer 314A to the second line buffer 314B.

[0024] The data driver 302 of the invention further includes a line buffer control circuit 322. The second line buffer 314B is composed of multiple line buffer units (not shown). The line buffer control circuit 322 outputs a second control signal C2 to the second line buffer 314B. The second line buffer 314B selectively outputs a channel of pixel data PD at a time under the control of the line buffer control circuit 322. That is, the second control signal C2 selects one line buffer unit at a time and the second line buffer 314B outputs the pixel data PD stored in the selected line buffer unit.

[0025] For example, each line buffer unit may be composed of a latch and a switch. The latch stores the pixel data PD and the switch turns on or off under the control of the second control signal C2. The way for selectively outputting the pixel data may include a step of, for example, turning on the switch of the selected line buffer unit according to the second control signal C2 in order to output the pixel data PD stored in the latch of the selected line buffer unit.

[0026] The DAC 316 converts a channel of pixel data PD into analog data at a time and also outputs a channel of analog pixel data APD at a time.

[0027] In addition, the analog buffer 317 may be composed of multiple analog buffer units that include analog buffer units (1) to (384). Each analog buffer unit may be implemented by a sample and hold circuit. An analog buffer control circuit 324 controls the analog buffer 317 and outputs third control signals C3 to control the analog buffer 317. The third control signals include signals C3-1 to C3-384 for controlling the analog buffer units (1) to (384), respectively. The analog buffer units sequentially receive the analog pixel data APD output from the DAC 316 under the control of the third control signals C3. A channel of the analog pixel data APD output from the DAC 316 is stored in the analog buffer units (1) to (384) at a time. After the analog buffer 317 finishes its receiving operations, the analog buffer 317 parallelly and simultaneously outputs the analog pixel data APD to the output buffer 318.

[0028] The third control signals C3 output from the analog buffer control circuit 324 may control the analog buffer 317

in the following manners. The third control signals **C3** may select an analog buffer unit, which is to be electrically connected to the DAC **316**, to receive the analog pixel data APD output from the DAC **316**. The third control signals **C3** may also control the analog buffer unit to output the analog pixel data APD at a predetermined time point. For example, the third control signals **C3** may control the analog buffer units **(1)** to **(384)** to simultaneously output 384 channels of analog pixel data APD to the output buffer **318** after 384 channels of analog pixel data APD are received.

[0029] The operations of the data driver **302** as shown in **FIG. 3** will be further described in the following. Since the operations of the data driver **302-1** to **302-8** are substantially the same, only the data driver **302-1** is described as an example.

[0030] It is assumed that the first line buffer **314A-1** receives two ports of pixel data PD (i.e., six channels of pixel data including two channels of red pixel data, two channels of blue pixel data, and two channels of green pixel data) at a time. If each channel of pixel data PD has 8 bits, the first line buffer **314A-1** receives 48 (=6×8) bits of pixel data PD at each time. By enabling one of the 64 bits in the shift register **312-1** (i.e., by enabling one of the control signals **C'-1(1)** to **C'-1(64)**), it is possible to select different storage addresses of the first line buffer **314A-1** and to store the received pixel data PD in a corresponding storage address in the first line buffer **314A-1**. Therefore, the 384 channels of pixel data PD can be completely received after the first line buffer **314A-1** has received the data at 64 times, wherein the first line buffer **314A-1** may have a capacity of 6×64×8 bits.

[0031] After the first line buffer **314A-1** finishes its receiving operations, all the pixel data PD stored in the first line buffer **314A-1** are parallelly and simultaneously transferred to the second line buffer **314B-1**, wherein the second line buffer **314B-1** may also have a capacity of 6×64×8 bits.

[0032] After the second line buffer **314B-1** completely receives the pixel data PD stored in the first line buffer **314A-1**, the second line buffer **314B-1** selectively outputs a channel of pixel data PD to the DAC **316-1** at a time under the control of the line buffer control circuit **322-1**, thereby converting the pixel data PD into analog data. The second line buffer **314B-1** may have, for example, 384 line buffer units, which are assumed to be selected from left to right to output the digital pixel data PD stored therein. The DAC **316-1** performs 384 times of digital-to-analog conversion in order to completely convert 384 channels of digital pixel data PD stored in the second line buffer **314B-1**.

[0033] That is, the line buffer control circuit **322-1** controls the second line buffer **314B-1** to output a channel of stored pixel data PD one by one, the DAC **316-1** receives a channel of pixel data PD one by one, and a channel of pixel data PD are converted into analog data at a time. Therefore, the second line buffer **314B-1** has to output the pixel data PD at 384 times, and the digital-to-analog converting circuit **316-1** has to perform 384 times of digital-to-analog conversion in order to completely convert 384 channels of pixel data PD stored in the second line buffer **314B-1**. The converted analog pixel data APD is sequentially stored, one channel at a time, in the analog buffer units **(1)** to **(384)** of the analog buffer **317-1** under the control of the control signal **C3** output from the analog buffer control circuit **324-1**.

[0034] Then, after 384 channels of analog pixel data APD are completely stored in the analog buffer **317-1**, the analog buffer **317-1** outputs the 384 channels of analog pixel data APD to the output buffer **318-1** under the control of the control signal **C3** output from the analog buffer control circuit **324-1**. The analog pixel data APD passes through 384 output buffer units **(1)** to **(384)** such as 384 OP amplifiers in the output buffer **318-1**. The output buffer units **(1)** to **(384)** are electrically connected to the data lines, respectively.

[0035] The upper limit of the conversion time for the digital-to-analog conversion in the digital-to-analog converting circuit **316** of this embodiment may be up to 1/384 of scanning time. The so-called scanning time means the image display time for one row of pixels corresponding to one scan line, and substantially equals to the display time for one frame of the LCD divided by the number of scan lines. When the data pixel PD is input to the first line buffer **314A**, 3092 (=384×8) channels of pixel data PD has to be sequentially input to the first line buffers **314A-1** to **314A-8** within a period of scanning time. However, since each second line buffer **314B** only has to output 384 channels of pixel data within a period of scanning time (i.e., each DAC **316** only has to process 384 channels of pixel data within a period of scanning time), the speed of the second line buffer **314B** for outputting the pixel data PD and the processing speed of the DAC **316** may be one-eighth of the speed of the first line buffer **314A** for receiving the pixel data PD. That is, the operation frequency required by the DAC used in this invention may be eight times of the input frequency of the pixel data PD, and it is very easy to achieve the hardware requirement.

[0036] **FIG. 4** is a circuit diagram showing internal details of the analog buffer in **FIG. 3**. Each analog buffer unit is implemented by a sample and hold circuit, and each sample and hold circuit is composed of switches **S1**, **S2**, **S3**, and **S4**, and capacitors **C1** and **C2**. When 384 channels of analog pixel data APD in some row of pixels are received, the switches **S1(1)** to **S1(384)** turn on, which enables the analog pixel data APD to be sequentially stored in the capacitors **C1(1)** to **C1(384)**. When 384 channels of analog pixel data APD in a next row of pixels are received, the switches **S1(1)** to **S1(384)** turn off while the switches **S3(1)** to **S3(384)** turn on, which enables 384 channels of analog pixel data APD of the next row of pixels to be stored in the capacitors **C2(1)** to **C2(384)**. Meanwhile, the switches **S2(1)** to **S2(384)** turns on, which enables the 384 channels of analog pixel data APD stored in the capacitors **C1(1)** to **C1(384)** to be output to the output buffer units **(1)** to **(384)**, respectively. When 384 channels of analog pixel data APD in a further next row of pixels are received, the switches **S1(1)** to **S1(384)** turn on while the switches **S3(1)** to **S3(384)** turns off, which enables the 384 channels of analog pixel data APD in the further next row of pixels to be stored in the capacitors **C1(1)** to **C1(384)**. Meanwhile, the switches **S4(1)** to **S4(384)** turn on, which enables the 384 channels of analog pixel data APD stored in the capacitors **C2(1)** to **C2(384)** to be output to the output buffer units **(1)** to **(384)**, respectively.

[0037] Comparing the data driver **302** of this embodiment in **FIG. 3** with the data driver **102** of **FIG. 2** may obtain the following results. Since the digital-to-analog converting circuit **216** in the data driver **102** requires 384 DACs to convert 384 channels of digital pixel data PD into analog

data and the data driver **302** of this embodiment only needs a DAC **316**, the embodiment may advantageously save the chip area.

[0038] FIG. 5 is a circuit block diagram showing multiple data drivers according to a second embodiment of the invention. Each data driver **502** includes a shift register **512**, a digital buffer **514**, multiple DACs, an analog buffer **517**, and an output buffer **518**. The digital buffer **514** may be composed of a first line buffer **514A** and a second line buffer **514B**.

[0039] The difference between the second embodiment and the first embodiment of FIG. 3 resides in that the digital-to-analog converting circuit **516** used in the data driver **502** of the second embodiment is composed of multiple DACs, the number of which is smaller than 384 and may be, for example, 6. That is, the DACs include DACs **516(1)** to **516(6)**. Consequently, six channels of pixel data PD may be output from the second line buffer **514B** to the DACs **516(1)** to **516(6)** and converted from digital data to analog data simultaneously under the control of the line buffer control circuit **322**. The six channels of converted analog pixel data APD may be simultaneously stored in six analog buffer units for further processing under the control of the analog buffer control circuit **324**.

[0040] In the two above-mentioned embodiments, the capacities of the shift register and the line buffer of the data driver may be changed in different designs. The resolution of the LCD, the bit number of the pixel data transferred to the data driver at each time, and the channel number of the pixel data that is converted by the DAC at each time may also be adjusted according to the design requirements. Also, the digital buffer may be replaced by a buffer or memory that can selectively output data. Any modification that is made within the objective of selectively converting digital pixel data into analog data is intended to be within the range of the invention. Although the shift register, the line buffer control circuit, and the analog buffer control circuit are divided into different circuits in the examples, two or more than two circuits may be integrated into a specific control circuit.

[0041] The data driver disclosed in the above-mentioned embodiments of the invention has the following advantages. Since the number of DACs is greatly reduced as compared with the prior art, the invention may effectively reduce the chip area that is occupied by the DACs and thus the cost.

[0042] While the invention has been described by way of example and in terms of a preferred embodiment, it is to be understood that the invention is not limited thereto. On the contrary, it is intended to cover various modifications and similar arrangements and procedures, and the scope of the appended claims therefore should be accorded the broadest interpretation so as to encompass all such modifications and similar arrangements and procedures.

What is claimed is:

1. A data driver for driving multiple data lines on an LCD panel according to multiple channels of pixel data, the data driver comprising:

a digital buffer for receiving and storing the pixel data at several times and selectively outputting a channel of the pixel data at a time;

a DAC (digital-to-analog converter) for receiving the pixel data output from the digital buffer at several times, converting the pixel data into multiple channels of analog pixel data and outputting the analog pixel data at several times;

an analog buffer for receiving the analog pixel data output from the DAC at several times and for outputting the analog pixel data at a time; and

an output buffer for receiving the analog pixel data output from the analog buffer so as to drive the data lines.

2. The data driver according to claim 1, further comprising a shift register for commanding the digital buffer to receive the pixel data.

3. The data driver according to claim 1, wherein the digital buffer includes a first line buffer and a second line buffer; the first line buffer receives and stores the pixel data at several times; when the first line buffer finishes its receiving operations, the first line buffer parallelly transfers all the pixel data stored therein to the second line buffer; and the second line buffer outputs a channel of the pixel data to the DAC at a time.

4. The data driver according to claim 3, further comprising a line buffer control circuit, and the second line buffer comprising multiple line buffer units, wherein the line buffer control circuit selects one of the line buffer units at a time, and the second line buffer outputs the pixel data stored in the selected line buffer unit.

5. The data driver according to claim 1, wherein the analog buffer comprises multiple analog buffer units and the analog buffer units receive the analog pixel data output from the DAC at several times.

6. The data driver according to claim 5, further comprising an analog buffer control circuit for commanding the analog buffer to receive the analog pixel data output from the DAC and to store the analog pixel data in the analog buffer units at several times, and for commanding the analog buffer to parallelly output the analog pixel data to the output buffer after the analog buffer finishes its receiving operations.

7. A data driver for driving multiple data lines on an LCD panel according to multiple channels of pixel data, the data driver comprising:

a digital buffer for receiving and storing the pixel data at several times and selectively outputting N channels of the pixel data at a time, wherein N is a positive integer greater than 1 and smaller than the number of the data lines;

N sets of DACs (digital-to-analog converters) for receiving the pixel data output from the digital buffer, simultaneously converting N channels of the pixel data into N channel of analog pixel data, and outputting the analog pixel data;

an analog buffer for receiving the analog pixel data output from the DACs at several times and outputting the analog pixel data at a time; and

an output buffer for receiving the analog pixel data output from the analog buffer so as to drive the data lines.

8. The data driver according to claim 7, further comprising a shift register for commanding the digital buffer to receive the pixel data.

9. The data driver according to claim 8, wherein the digital buffer comprises a first line buffer and a second line

buffer; the first line buffer receives and stores the pixel data at several times; when the first line buffer finishes its receiving operations, the first line buffer parallelly transfers all the pixel data stored therein to the second line buffer; and the second line buffer selectively outputs N channels of the pixel data to the DACs at a time.

10. The data driver according to claim 9, further comprising a line buffer control circuit, and the second line buffer comprising multiple line buffer units, wherein the line buffer control circuit selects N line buffer units from the line buffer units at a time, and the second line buffer outputs the pixel data stored in the selected line buffer units.

11. The data driver according to claim 7, wherein the analog buffer comprises multiple analog buffer units, which receive the digital pixel data output from the DACs at several times.

12. The data driver according to claim 11, further comprising an analog buffer control circuit for commanding the analog buffer to receive the pixel data output from the DACs and to store the pixel data in the analog buffer units at several times, and for commanding the analog buffer to parallelly output the pixel data to the output buffer after the analog buffer finishes its receiving operations.

* * * * *

专利名称(译)	LCD面板的数据驱动程序		
公开(公告)号	US20040155849A1	公开(公告)日	2004-08-12
申请号	US10/668983	申请日	2003-09-22
[标]申请(专利权)人(译)	BU莲溪 萧川澄 陈颜真卿		
申请(专利权)人(译)	BU LIN-KAI 萧传成 陈YEN-CHEN		
当前申请(专利权)人(译)	BU LIN-KAI 萧传成 陈YEN-CHEN		
[标]发明人	BU LIN KAI HSIAO CHUAN CHENG CHEN YEN CHEN		
发明人	BU, LIN-KAI HSIAO, CHUAN-CHENG CHEN, YEN-CHEN		
IPC分类号	G02F1/133 G09G3/20 G09G3/36		
CPC分类号	G09G3/2011 G09G2310/027 G09G3/3688		
优先权	092102692 2003-02-10 TW		
其他公开文献	US7184016		
外部链接	Espacenet USPTO		

摘要(译)

一种数据驱动器，用于根据多个像素数据通道在LCD面板上驱动多条数据线。在数据驱动器中，数字缓冲器多次接收并存储像素数据，并且一次选择性地输出像素数据的通道。DAC多次接收从数字缓冲器输出的像素数据，将像素数据转换为多个模拟像素数据通道，并多次输出模拟像素数据。模拟缓冲器多次接收从DAC输出的模拟像素数据，并一次输出模拟像素数据。输出缓冲器接收从模拟缓冲器输出的模拟像素数据，以便驱动数据线。

