



(19) **United States**

(12) **Patent Application Publication**

(10) **Pub. No.: US 2004/0062057 A1**

Ha et al.

(43) **Pub. Date:**

Apr. 1, 2004

(54) **LIQUID CRYSTAL DISPLAY DEVICE AND BACKLIGHT THEREOF**

(52) **U.S. Cl.** 362/561; 362/31

(75) **Inventors:** **Kyoung Su Ha**, Pusan (KR); **Myong Gi Jang**, Kyungsangbuk-do (KR)

(57) **ABSTRACT**

Correspondence Address:
BIRCH STEWART KOLASCH & BIRCH
PO BOX 747
FALLS CHURCH, VA 22040-0747 (US)

In a liquid crystal display device according to the present invention, an upper end portion of a lamp housing is fixed on a main supporter so that the lamp housing can be made to face a side edge of a light guide. Light that can cause bright lines is eliminated or minimized through absorption or scattering by a main supporter. The main supporter is also thermally insulating and is placed between the lamp housing and a liquid crystal panel. Further, a thermally conducting bottom cover is placed under the backlight. Therefore, heat generated from the lamp is effectively channeled away from the light guide to prevent liquid crystal panel deterioration. Still further, although the upper and lower surfaces of the light guide is tightly fit between the lamp housing and the main supporter, wrinkles on a sheet reflector are prevented because the sheet reflector is not stacked between the lamp housing and a lower surface of the light guide.

(73) **Assignee:** **LG. PHILIPS LCD CO., LTD.**

(21) **Appl. No.:** **10/673,447**

(22) **Filed:** **Sep. 30, 2003**

(30) **Foreign Application Priority Data**

Apr. 30, 1999 (KR) 1999-15641

Publication Classification

(51) **Int. Cl.⁷** **F21V 7/04**

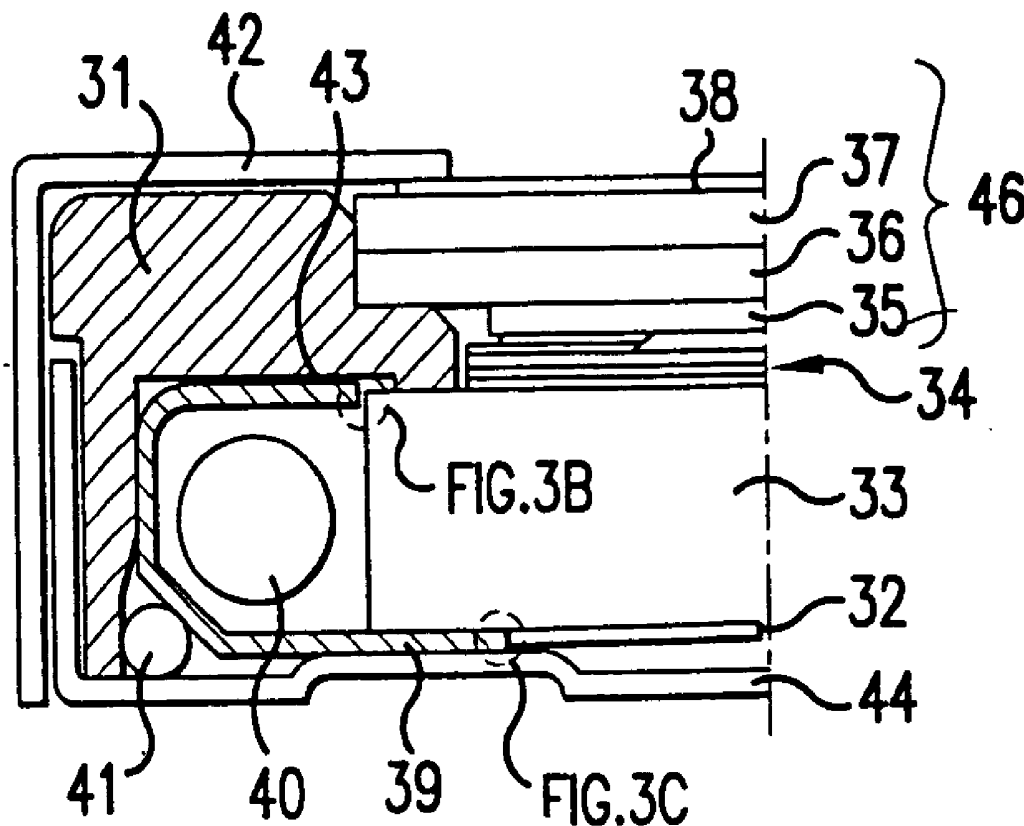

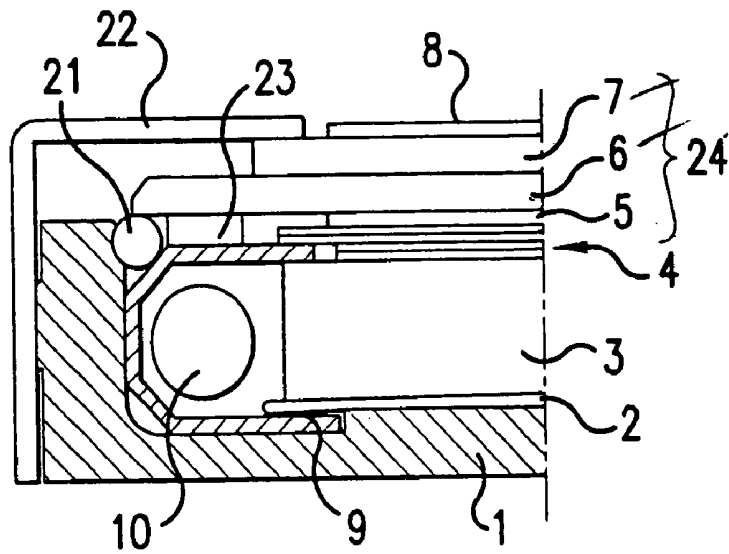

FIG. 1
CONVENTIONAL ART

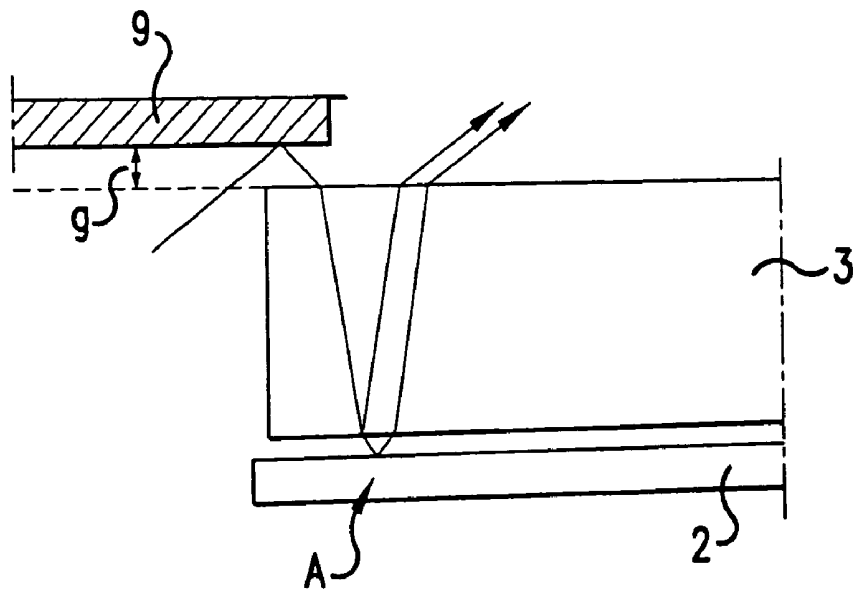

FIG. 2
CONVENTIONAL ART

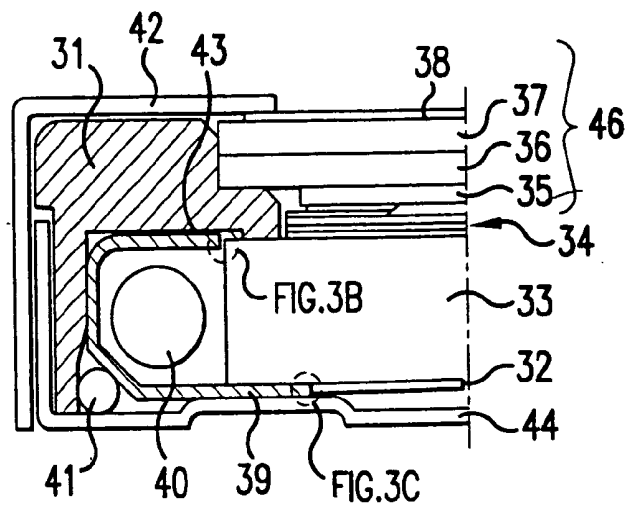

FIG. 3A

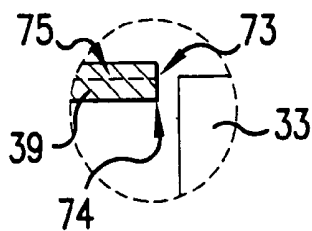

FIG. 3B

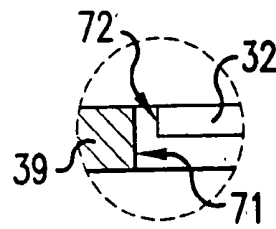

FIG. 3C

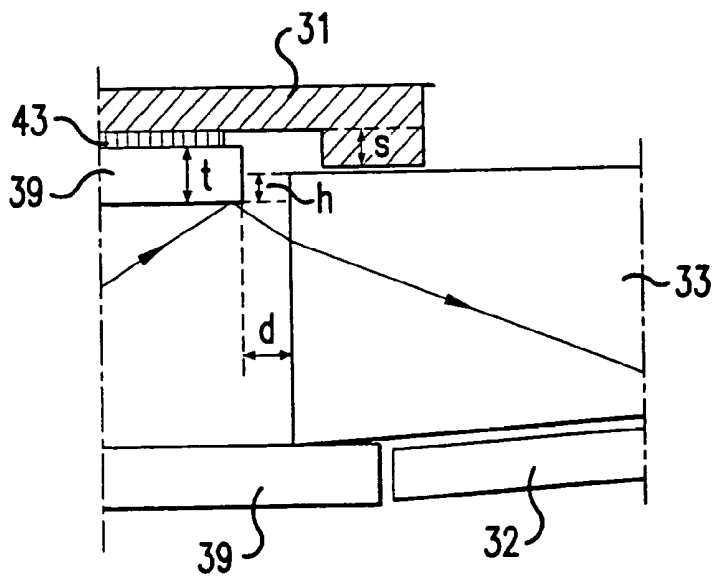

FIG. 4

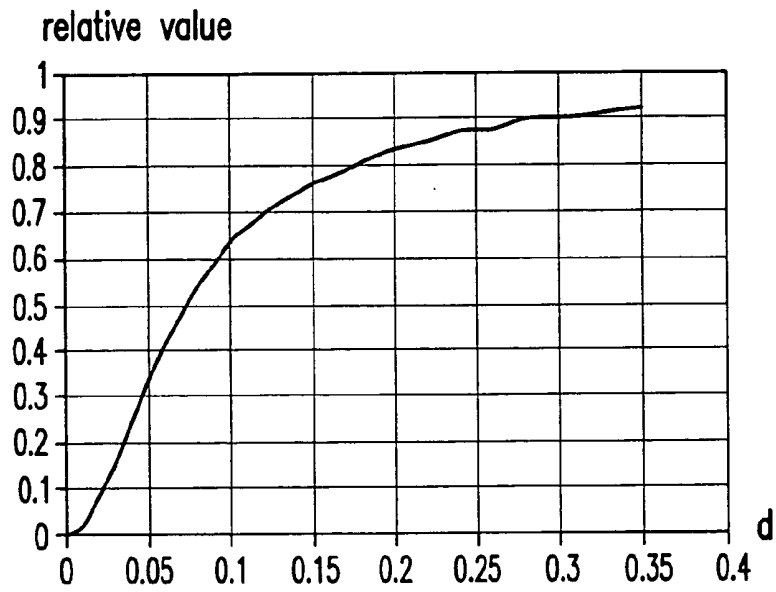

FIG.5

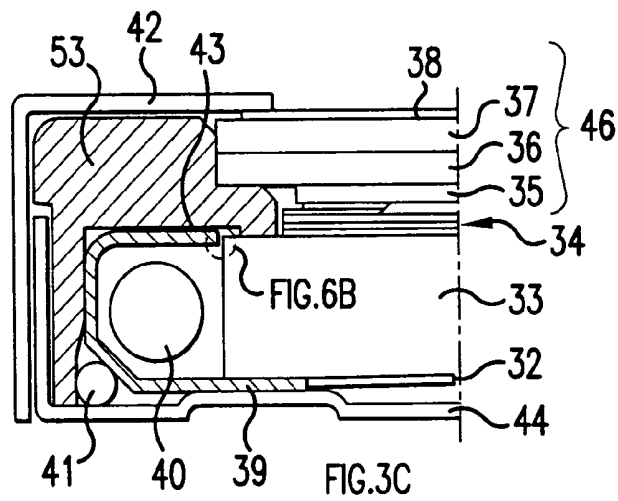

FIG.6A

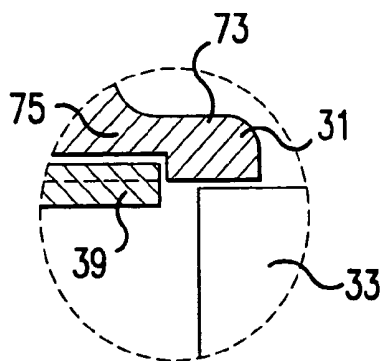

FIG.6B

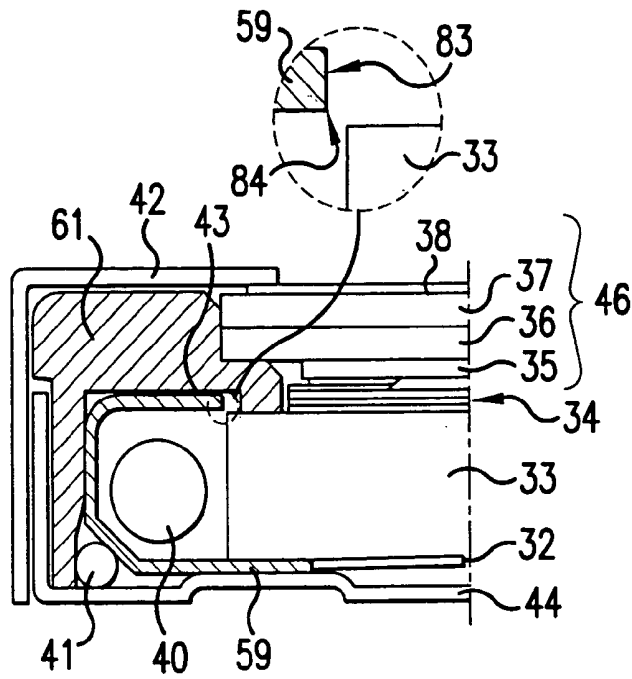

FIG. 7

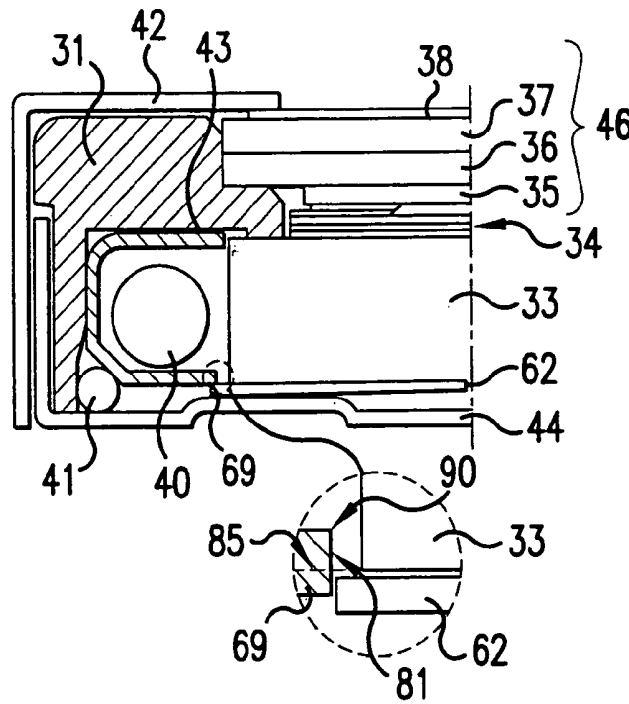

FIG. 8

LIQUID CRYSTAL DISPLAY DEVICE AND BACKLIGHT THEREOF

BACKGROUND OF THE INVENTION

[0001] The present invention relates to a liquid crystal display device and a backlight thereof. More specifically, the present invention relates to preventing the deterioration of liquid crystal panel and preventing the generation of wrinkles on a sheet reflector while decreasing generations of a bright line and/or a black line.

[0002] A liquid crystal display device (LCD) has been widely used as a display for notebook computers and portable TVs among others. An LCD fundamentally includes a liquid crystal panel and a backlight applying a lamp light to the liquid crystal panel. The liquid crystal panel typically comprises an upper substrate, a lower substrate, and a liquid crystal layer between the two substrates.

[0003] FIG. 1 is a sectional view showing a position of a lamp of a conventional LCD device including a liquid crystal panel and a backlight. The liquid crystal panel 24 comprises an upper substrate 7, a lower substrate 6, a liquid crystal layer between the two substrates (not shown), an analyzer 8 adhered to an upper surface of the upper substrate 7 and a polarizer 5 adhered to a lower surface of the lower substrate 6.

[0004] The backlight comprises a light guide 3, a lamp 10 facing a side edge of the light guide 3, a lamp wire 21, a lamp housing 9, a sheet reflector 2 situated below the light guide 3, and a plurality optical films 4 adhered to an upper surface of the light guide 3. The lamp wire 21 supplies power to the lamp 10, and the lamp housing 9 protects the lamp 10 and directs the light therefrom to the light guide 3 through the side edge of the light guide.

[0005] The conventional LCD device also includes a pad 23, a main supporter 1, and a top case 22, which is connected to a side of the main supporter and an upper end of the liquid crystal panel 24. Pad 23 is situated between an upper surface of the upper end of the lamp housing 9 and the lower surface of the lower substrate to support the liquid crystal panel 24. The main supporter 1 shields the lower portion and the side of the backlight protects and supports the backlight. The top case 22 fixes the liquid crystal panel 24 to the main supporter 1.

[0006] The conventional LCD device has following problems.

[0007] First, after the construction, the edge of light guide 3 is placed between both upper and lower extensions of the lamp housing 9. To prevent wrinkles on the sheet reflector 2 with this construction, a gap must occur between the upper surface of the light guide 3 and the lower surface of the upper end of the lamp housing 9.

[0008] Normally, light from the lamp 10 is incident upon the side edge of the light guide 3 so that the light density, emitted through the upper surface of the liquid crystal display panel 24, is uniform over a wide region. However, the gap created by the above construction results in some of the light rays being reflected from the lamp housing 9 so as to be incident upon the upper surface of the light guide 3, as shown in FIG. 2. Thus, instead of the desired uniform light brightness, a bright line is created.

[0009] To counteract the bright line creation, a black color is printed on an area A of the sheet reflector 2. Unfortunately, if the print density is too great, then a black line is generated, and if the print density is too slight, then the bright line will still be generated.

[0010] Second, to prevent the bright line, the aperture of the lamp housing 9 can be made narrow. However, such narrowing of the opening causes the a portion of sheet reflector 2 above the lower extension of the lamp housing 9 to be pressed by the same lower extension. As a result, wrinkles are generated on the sheet reflector 2, especially at high temperatures.

[0011] Third, heat generated from the lamp 10 is transmitted to the liquid crystal panel 24 and thereby causing the liquid crystal to deteriorate.

SUMMARY OF THE INVENTION

[0012] In order to overcome the problems according to the conventional art, the present invention provides an LCD device including a backlight thereof in which the generation of a bright line and/or a black line is prevented, the deterioration of the liquid crystal generated is prevented, and the generation of wrinkles is prevented on a sheet reflector.

[0013] In order to achieve the objects described above, the liquid crystal display device according to the present invention comprises:

[0014] A liquid crystal panel; a light guide including the first surface which faces the liquid crystal panel as an upper side, the second surface as a lower side, a plane of incident ray on at least one end surface; a lamp facing the plane of incident rays; a lamp housing including the first end portion provided on the first surface, the second end portion provided on the second surface as two end portions which has a regular intervals with the perpendicular direction to the first surface and an inner side holding the lamp.

[0015] Also, the liquid crystal display device also includes a main supporter between the lamp housing and the liquid crystal panel; wherein the first boundary which is formed between the first end portion and the inner side is situated between the first expanded surface having the perpendicular direction to the plane of the incident rays, as an imaginary expanded surface of the first surface and the second expanded surface having the perpendicular direction to the plane of the incident rays, as an imaginary expanded surface of the second surface; the end portion in the direction of the plane of incident rays in the sheet reflector, in which the end portion is confronted with the second surface, is further than the second end portion on the basis of the plane of the incident rays.

[0016] An upper end portion of a lamp housing is fixed on the main supporter, so that the lamp housing can be controlled to confront with a plane of incident rays at a light guide for a correct position. Also a causative light of a bright line which is streaming through the corner of a upper surface of the light guide is effectively intercepted and the causative light is scattered or absorbed by the main supporter.

[0017] Further, the main supporter intercepts heat moving from a lamp to a liquid crystal panel, so that a deterioration of liquid crystal is decreased.

[0018] And, the sheet reflector is not inserted between the lamp housing and a lower surface of the light guide, so that though the upper and lower surface of the light guide is intensively fitted by the lamp housing and the main supporter, wrinkles are not generated on the sheet reflector and the whole thickness of the backlight can be decreased as much as thickness of the sheet reflector.

[0019] Advantages of the present invention will become more apparent from the detailed description given hereinafter. However, it should be understood that the detailed description and specific examples, while indicating preferred embodiments of the invention, are given by way of illustration only, since various changes and modifications within the spirit and scope of the invention will become apparent to those skilled in the art from this detailed description.

BRIEF DESCRIPTION OF THE DRAWINGS

[0020] The present invention will become more fully understood from the detailed description given hereinbelow and the accompanying drawings which are given by way of illustration only, and thus do not limit the present invention.

[0021] FIG. 1 is a sectional view showing an LCD device according to the conventional art.

[0022] FIG. 2 is a sectional view explaining the reason why a bright line is generated in an LCD device according to the conventional art.

[0023] FIGS. 3A, 3B and 3C are sectional views showing an LCD device according to a first embodiment of the present invention.

[0024] FIG. 4 is a view explaining effects of the first embodiment.

[0025] FIG. 5 is a graph showing a relative value of a luminous intensity of a bright line according to the first embodiment to the luminous intensity of a bright line according to the conventional art, depending on a distance *d* shown in FIG. 4.

[0026] FIGS. 6A and 6B are sectional views showing another practical structure according to the present invention.

[0027] FIG. 7 is a sectional view showing a second embodiment of the present invention.

[0028] FIG. 8 is a sectional view showing a third embodiment of the present invention.

DETAILED DESCRIPTION OF THE INVENTION

[0029] FIG. 3A is a view showing a first embodiment of the present invention. A backlight of the first embodiment comprises a light guide 33, a lamp 40 facing a side edge of the light guide 33, a lamp wire 41 to supply power to the lamp 40, a lamp housing 39 to protect and shield the lamp 40 and to direct light to the side edge of the light guide 33, a sheet reflector 32 situated below a lower surface of the light guide 33, and a plurality optical films 34 situated above an upper surface of the light guide 33.

[0030] In the conventional art, as shown in FIG. 1, the end portion of the sheet reflector 2 is inserted between the lower surface of the light guide 3 and the lower extension of the lamp housing 9. But in the first embodiment, as shown in FIG. 3C, an end portion 72 of the sheet reflector 32 and the end portion 71 of the lower extension of the lamp housing 39 are apart from each other. As a result, the sheet reflector 32 is not pressed by the lamp housing 39, which prevents wrinkles from being generated on the sheet reflector 32.

[0031] Also as shown in FIG. 1, the conventional LCD device has a portion of the upper extension of the lamp housing 9 extends over a portion of the upper surface of the light guide 3. In the first embodiment according to the present invention (as shown in more detail in FIG. 3B), however, at least a portion of the side edge 73 of the upper extension of the lamp housing 39 faces the side edge of the light guide 33. In other words, no vertical gap exists between the upper surface of the light guide 33 and the lower surface of the upper extension of the lamp housing 39, as is the case in the conventional art.

[0032] The lack of a vertical gap prevents a bright line from being created. As shown in FIG. 4, light rays reflected from the lower surface of the upper extension still enters the light guide 33 through the side edge instead of entering through the upper surface as in the conventional art. This construction has an additional advantage in that overall brightness is increased since more light enters through the side edge of the light guide 33.

[0033] It is true that some amount of light will enter the horizontal gap between the lamp housing 39 and the light guide 33 and be reflected from a main supporter 31. However, any bright line effect created by such light is insignificant for two reasons. First, the amount of light that enters the gap to be reflected is so small as to be negligible. Second, the amount light actually reflected onto the upper surface of the light guide 33 is further reduced through absorption by the end 73 of the upper extension of the lamp housing 39 and by the main supporter 31.

[0034] As shown in FIG. 3, a liquid crystal panel 46 comprises an upper substrate 37, a lower substrate 36, a liquid crystal layer between the two substrates (not shown), an analyzer 38 adhered on the upper surface of the upper substrate 37, and polarizer 35 adhered to the lower surface of the lower substrate 36. The liquid crystal panel 46 is situated on the optical film 34 of the backlight.

[0035] The LCD device of the first embodiments also includes a bottom cover 44, which generally covers side and bottom of the LCD device including the backlight. The device also includes a top case 42, which covers a portion the upper edge of the liquid crystal panel 46 above the side edge of the light guide 33 as well as a side portion of the bottom cover 44. The bottom cover 44 is composed of thermally conducting materials such as metals. The top case 42 and the bottom cover 44 may be formed as a single unit.

[0036] As shown in FIG. 3A, the main supporter 31 is adjoined with a lower edge of the liquid crystal panel 46 to provide support to the liquid crystal panel 46. Also one end portion of the main supporter 31 is above the upper surface of the light guide 33, and the other end portion is aside an inner surface of the bottom cover 44. The main supporter 31 is composed of thermally insulating materials such as plas-

tics. Also, it is preferred that the main supporter 31 is composed of a material that scatters or absorbs light.

[0037] Note that the main supporter 31 has an end portion that is between the liquid crystal panel 46 and the lamp housing 39. Because the main supporter 31 is thermally insulating, most of the heat generated from the lamp 40 is transferred outside through the lamp housing 39 and through the bottom cover 44 and top case 42, which are thermally conducting, without transmitting the heat into the liquid crystal panel 46. This prevents or minimizes the deterioration of the liquid crystal panel 46.

[0038] Further, the light rays that enter the horizontal gap between the end 73 of the upper extension of the lamp housing 39 and the side edge of the light guide 33 are scattered or absorbed by the main supporter 31, which prevents or minimizes bright lines from occurring.

[0039] The lamp housing 39 is fixed onto the main supporter 31 by a double-faced adhesive tape 43 which is placed between an outer side of the lamp housing 39 and an inner side of the main supporter 31. An upper portion of the main supporter 31 is formed higher than the end portion of the main supporter, which is connected with the upper surface of the light guide. In this case, another fixing technology can be used above and beyond the double-faced adhesive tape to minutely control the position of the end portion of the upper extension of the lamp housing 39.

[0040] Note that above the upper surface and below the lower surface of the light guide 33, the end portion of the main supporter 31 and the lower extension of the lamp housing 39 are placed, respectively. The light guide 33 is tightly fit between the main supporter 31 and the lamp housing 39. This differs from the conventional art shown in FIG. 1 in which the sheet reflector 2 is inserted between the lower extension of the housing 9 and the lower surface of the light guide 3. A tight fit under this condition results in wrinkles being generated on the sheet reflector 2.

[0041] To prevent wrinkles in the convention art, a gap g of about 0.1 mm is created between the upper surface of the light guide 3 and the upper extension of the lamp housing 9, as shown in FIG. 2. Also, the thickness of the light guide 3 and the position of the upper extension of the lamp housing 9 have a tolerance of about ± 0.1 mm. Thus, the gap g could be as much as 0.2 mm. If the gap is so large, the bright line cannot be prevented.

[0042] But in the first embodiment, as shown in FIG. 3C, the sheet reflector 32 is not inserted between the lower extension of the lamp housing 39 and the lower surface of the light guide 33. This allows for the light guide 33 to be tightly fit between the main supporter 31 and the lower extension of the lamp housing 39 without a concern that the sheet reflector 32 will be wrinkled. The tight fit dramatically reduces the gap between the upper surface of the light guide and the main supporter, which in turn prevents or minimizes the creation of bright lines.

[0043] FIG. 5 is a graph showing a relative value of a luminous intensity of the bright line of the first embodiment to a luminous intensity of the bright line according to the conventional art, depending on the gap d shown in FIG. 4. The graph reflects a situation where height difference h between the upper surface of the light guide 33 and the lower surface of the upper extension of the lamp housing has been

fixed to 0.1 mm. In this instance, the lower surface of the upper extension has been fixed to be above the upper surface of the light guide (unlike the situation depicted in FIG. 4). The relative luminosity values have been calculated by using the direction distribution of light near the end portion of the upper extension of the lamp housing. The distribution is obtained from measuring samples under a condition that space above the upper surface of the light guide is 0.1 mm in both the conventional art and the first embodiment.

[0044] As shown in graph, when the horizontal gap d is 0.1 mm or less (i.e. the ratio of the horizontal gap to the vertical gap is 1 or less), the relative luminosity value is 0.6 or less as compared to the conventional art. That is, the strength of a bright line is considerably decreased in the first embodiment.

[0045] As noted above, the graph of FIG. 5 represents data generated under the condition where a significant gap (0.1 mm) exists between the upper surface of the light guide 33 and the lower surface of the upper extension of the main housing 39. Stated in another way, this situation depicts a very loose fit. But also as noted above, the fit can be tightened to where the gap is much less than 0.1 mm, which will significantly decrease the bright line strength.

[0046] Referring back to FIG. 4, it is desirable to have the height h , the distance at which the upper surface of the light guide 33 is above the lower surface of the upper extension of the lamp housing 39, be as close to zero as possible to maximize the amount of light from the lamp 40 entering the side edge of the light guide 33 without increasing the bright line strength. The height h is determined by the step difference s of the main supporter 31, the thickness t of the lamp housing 39, and the thickness of the adhesives. All these factors can be controlled within 0.1 mm tolerance. Thus, the height h can be very accurately produced, i.e. to within 0.05 mm or less. As a result, light incident to the side edge of the light guide 33 can be maximized while effectively excluding creation of bright lines.

[0047] As described above, upper extension of the lamp housing 39 does not contact the light guide 33. However, it is possible that an external shock may jar the device such that the lamp housing and the light guide collide. If this occurs, the light guide maybe damaged to spill impurities from the light guide to the liquid crystal panel causing spots on the LCD screen. To ensure that the chance of collision is minimized, the lamp housing 39 is affixed to the main supporter 31 by a double-faced adhesive tape 43.

[0048] FIGS. 6A and 6B show a further step that can be taken to minimize the chance of collision. As shown in more detail in FIG. 6B, a portion of the main supporter 31 above the upper surface of the light guide 33 extends into the space (gap d of FIG. 4) where the upper extension of the lamp housing 39 and the side edge of the light guide 33 are kept apart. Here, a part 75 of the end 73 of the upper extension (the part that is above the upper surface of the light guide 33) rests against the extended portion of the main supporter 31, thereby ensuring collision will not occur.

[0049] However, because gap d exists, some amount of light may enter through the gap d . In the conventional art, the light entering in such a manner was reflected to enter the light guide 33 through the upper surface causing bright lines. In the first embodiment, however, the main supporter 31 is

made of a material that absorbs and scatters light. Thus, the light that enters through the gap *d* is scattered or absorbed preventing bright lines.

[0050] Referring back to **FIG. 3**, a black line can be generated from light that escapes through a space between the end portion **72** of the lower extension of the lamp housing **39** and the sheet reflector **32**. To prevent or minimize black lines from occurring, the bottom cover **44** can be made of appropriate materials.

[0051] **FIG. 7** is a view showing a second embodiment according to the present invention. Elements having the same structure as the first embodiment are represented with same reference numbers, and related explanations are omitted.

[0052] In the second embodiment, the end portion **83** of the upper extension of the lamp housing **59** does not face the side edge the light guide **33**. That is, the upper extension of the lamp housing **59** is entirely above the upper surface of the light guide **33**.

[0053] In this structure, the inner space of the lamp housing **59** is wider than the inner space of the lamp housing of the first embodiment. This in turn decreases the amount of light being absorbed after being reflected back into the lamp **40** is decreased, and increases the amount of light entering the side edge of the light guide **33** when compared to the first embodiment. More light incident to the side edge of the light guide **33** increases the brightness of the plane lamp.

[0054] Also as mentioned previously, because the light entering the gap is scattered or absorbed by the main supporter **31**, the bright line is still considerably less when compared to the conventional art.

[0055] **FIG. 8** is a view showing a third embodiment according to the present invention. Elements having the same structure as the first embodiment are represented with same reference numbers, and related explanations are omitted.

[0056] In this embodiment, a portion **81** of the edge of the lower extension of the lamp housing **69** faces the side edge of the light guide **33**. That is, the lower extension of the lamp housing **69** is NOT entirely below the light guide **33**. This structure prevents or minimizes black lines from occurring by preventing or minimizing the light from escaping through the space between the lower extension of the lamp housing **69** and the side edge of the light guide **33**.

[0057] The embodiments discussed above all describe structures in which the upper extension of the lamp housing is spaced apart from the light guide to prevent collision between the lamp housing and the light guide. Additional measures as discussed previously and shown in **FIG. 6** can be taken to further prevent collision.

[0058] The embodiments of the present invention have the following advantages. First, bright lines are prevented or minimized. This is accomplished by at least one of 1) minimizing the amount of light escaping through the gap between the upper extension of the lamp housing and the light guide, and 2) by absorbing or scattering by the main supporter of the escaped light.

[0059] Second, wrinkles are prevented or minimized since the sheet reflector is not stacked between the light guide and

the lower extension of the lamp housing. This has the further advantage that the overall thickness of the backlight can be decreased by the thickness of the sheet reflector.

[0060] Third, deterioration of the liquid crystal panel is prevented or minimized due to heat transfer away from the liquid crystal panel by the main supporter, the bottom cover, and the top case.

[0061] Fourth, the brightness of the plane lamp is enhanced by maximizing the amount of light incident to the side edge of the light guide.

[0062] As many apparently widely different embodiments of this invention may be made without departing from the spirit and scope thereof, it is to be understood that the invention is not limited to the specific embodiments thereof.

What is claimed is:

1. A backlight of a liquid crystal display device, comprising:

a light guide having an end surface, an upper surface, and a lower surface;

a lamp facing said end surface; and

a lamp housing having an inner side holding said lamp inside, said lamp housing including an upper end portion and a lower end portion, wherein there is no vertical gap between a lower side of said upper end portion and said upper surface of said light guide.

2. The backlight according to the claim 1, wherein said upper end portion of said lamp housing is apart from said edge surface of said light guide.

3. The backlight according to the claim 2, wherein said lower side of said upper end portion of said lamp housing is lower than said upper surface of said light guide.

4. The backlight according to the claim 1, further comprising:

a sheet reflector disposed below said light guide and next to said lower end portion of said lamp housing, and wherein a part of said lower end portion is also disposed below said light guide.

5. A liquid crystal display device, comprising:

a liquid crystal panel;

a light guide disposed below said liquid crystal panel, said light guide having an end surface, an upper surface, and a lower surface;

a lamp facing said end surface;

a lamp housing having an inner side holding said lamp inside, said lamp housing including an upper end portion and a lower end portion; and

a main supporter, a portion of which is between said lamp housing and said liquid crystal panel.

6. A liquid crystal display device according to claim 5, wherein said main supporter is on said upper surface and near said end surface of said light guide.

7. A liquid crystal display device according to claim 5, wherein said upper end portion of said lamp housing is affixed to said main supporter.

8. A liquid crystal display device according to claim 5, wherein said main supporter is connected to a lower side of said liquid crystal panel.

9. A liquid crystal display device according to claim 5, further comprising:

a first cover shielding said lower surface of said light guide; and

a second cover connecting an upper side of said liquid crystal panel and said first cover.

10. A liquid crystal display device according to claim 9, wherein said first cover is connected with said lamp housing.

11. A liquid crystal display device according to claim 5, wherein said main supporter includes a material scattering or absorbing a light.

12. A liquid crystal display device according to claim 9, wherein said first cover or said second cover includes a thermally conducting material.

13. A liquid crystal display device according to claim 5, wherein said main supporter includes a thermally insulating material.

14. A liquid crystal display device according to claim 5, wherein there is no vertical gap between a lower surface of said upper end portion of said lamp housing and said upper surface of said light guide.

15. A liquid crystal display device according to claim 5, wherein said lower surface of said upper end portion of said lamp housing is lower than said upper surface of said light guide.

16. A liquid crystal display device according to claim 5, wherein the first portion of said main supporter is on a part of said upper surface of said light guide, said main supporter also affixed to said upper end portion of said lamp housing.

17. A backlight for an LCD device, comprising:

a lamp housing including an upper extension;

a lamp light within said lamp housing; and

a light guide horizontally spaced apart from said upper extension.

18. The backlight of claim 17, wherein said lamp housing further includes a lower extension, said backlight further comprising:

a sheet reflector disposed below said guide light and horizontally spaced apart from said lower extension.

19. The backlight of claim 17, wherein at least a portion of said upper extension is below an upper surface of said light guide.

20. The backlight of claim 17, wherein said upper extension is entirely above an upper surface of said light guide.

21. The backlight of claim 18, wherein said light guide is disposed above at least a portion of said lower extension.

22. The backlight of claim 18, wherein at least a portion of said lower extension is above a lower surface of said light guide.

23. An LCD device, comprising:

a liquid crystal display panel;

a light guide disposed below said liquid crystal display panel;

a lamp housing including an upper extension, said upper extension being horizontally spaced apart from said light guide;

a plurality of optical films above at least a portion of the upper surface of said light guide;

a lamp light within said lamp housing; and

a lamp wire supplying power to said lamp light.

24. The LCD device of claim 23, wherein said lamp housing further includes a lower extension, said LCD device further comprising:

a sheet reflector disposed below said guide light and horizontally spaced apart from said lower extension.

25. The LCD device of claim 24, wherein at least a portion of said lower extension is above a lower surface of said light guide.

26. The LCD device of claim 23, further comprising:

a main supporter on a side of and above said lamp housing and wherein an end portion of said main supporter is above said light guide.

27. The LCD device of claim 26, wherein said main supporter and said lamp housing are affixed to each other.

28. The LCD device of claim 27, wherein said main supporter and said lamp housing are affixed to each other by a double-sided adhesive tape.

29. The LCD device of claim 26, wherein said end portion of said main supporter extends beyond a side edge of said light guide and buttresses against said upper extension of said lamp housing.

30. The LCD device of claim 26, wherein said main supporter is made of a thermally insulating material.

31. The LCD device of claim 30, wherein said thermally insulating material is plastic.

32. The LCD device of claim 26, wherein said main supporter is made of a material that absorb or scatter light.

33. The LCD device of claim 26, further comprising:

a bottom cover, made of a thermally conducting material, disposed below said lamp housing.

34. The LCD device of claim 33, further comprising:

a top case, made of a thermally conducting material, disposed above said main supporter and said liquid crystal panel.

35. An LCD device, comprising:

a liquid crystal display panel;

a light guide disposed below said liquid crystal display panel;

a lamp housing aside said light guide;

a main supporter on a side of and above said lamp housing, wherein said main supporter is thermally insulating;

a lamp light within said lamp housing; and

a lamp wire supplying power to said lamp light.

36. The LCD device of claim 35, further comprising:

a bottom cover, made of a thermally conducting material, disposed below said lamp housing.

37. The LCD device of claim 36, further comprising:

a top case, made of a thermally conducting material, disposed above said main supporter and said liquid crystal panel.

专利名称(译)	液晶显示装置及其背光		
公开(公告)号	US20040062057A1	公开(公告)日	2004-04-01
申请号	US10/673447	申请日	2003-09-30
[标]申请(专利权)人(译)	乐金显示有限公司		
申请(专利权)人(译)	LG.飞利浦液晶CO., LTD.		
当前申请(专利权)人(译)	LG DISPLAY CO., LTD.		
[标]发明人	HA KYOUNG SU JANG MYONG GI		
发明人	HA, KYOUNG SU JANG, MYONG GI		
IPC分类号	G02F1/1335 F21V8/00 G02B6/00 G02F1/13357 F21V7/04		
CPC分类号	G02B6/0031 G02F1/133615 G02B6/0088 G02B6/0055		
优先权	1019990015641 1999-04-30 KR		
其他公开文献	US7083318		
外部链接	Espacenet USPTO		

摘要(译)

在根据本发明的液晶显示装置中，灯壳的上端部固定在主支架上，使得灯壳可以面向光导的侧边缘。通过主支架的吸收或散射消除或最小化可以引起亮线的光。主支架也是绝热的，并且放置在灯壳和液晶面板之间。此外，导热底盖放置在背光下方。因此，从灯产生的热量被有效地引导远离光导，以防止液晶面板劣化。此外，尽管光导的上表面和下表面紧密地配合在灯壳和主支撑件之间，但是由于片反射器没有堆叠在灯壳和灯的下表面之间，所以防止了片反射器上的褶皱。指南。

