



US008467026B2

(12) **United States Patent**  
**Inoue et al.**

(10) **Patent No.:** **US 8,467,026 B2**  
(45) **Date of Patent:** **Jun. 18, 2013**

(54) **LIQUID CRYSTAL DISPLAY DEVICE AND ELECTRONIC APPARATUS**

(75) Inventors: **Yuichi Inoue**, Kanagawa (JP); **Ryo Ogawa**, Tokyo (JP); **Shunichi Suwa**, Kanagawa (JP)

(73) Assignee: **Sony Corporation**, Tokyo (JP)

(\* ) Notice: Subject to any disclaimer, the term of this patent is extended or adjusted under 35 U.S.C. 154(b) by 597 days.

(21) Appl. No.: **12/651,030**

(22) Filed: **Dec. 31, 2009**

(65) **Prior Publication Data**

US 2010/0182521 A1 Jul. 22, 2010

(30) **Foreign Application Priority Data**

Jan. 20, 2009 (JP) ..... P2009-009524

(51) **Int. Cl.**  
**G02F 1/1343** (2006.01)

(52) **U.S. Cl.**  
USPC ..... 349/144

(58) **Field of Classification Search**  
USPC ..... 349/144  
See application file for complete search history.

(56) **References Cited**

U.S. PATENT DOCUMENTS

2004/0150775	A1*	8/2004	Nakasogi et al.	349/130
2005/0100784	A1*	5/2005	Yageta et al.	429/160
2006/0164585	A1*	7/2006	Shih	349/144
2007/0146589	A1*	6/2007	Ohmuro et al.	349/113
2007/0216844	A1*	9/2007	Chin et al.	349/144
2008/0180607	A1	7/2008	Su et al.	

FOREIGN PATENT DOCUMENTS

JP	2008-189610	8/2008
JP	2010-033054	2/2010
JP	2010-128211	6/2010

\* cited by examiner

*Primary Examiner* — Timothy L Rude

(74) *Attorney, Agent, or Firm* — Finnegan, Henderson, Farabow, Garrett & Dunner, LLP

(57) **ABSTRACT**

A liquid crystal display device includes: a plurality of pixel electrodes formed of a frame-shaped connection electrode and electrode bodies arranged in parallel to one another in a frame of the connection electrode and supported by and connected to the connection electrode; and a common electrode insulated from the plurality of pixel electrodes.

**9 Claims, 9 Drawing Sheets**

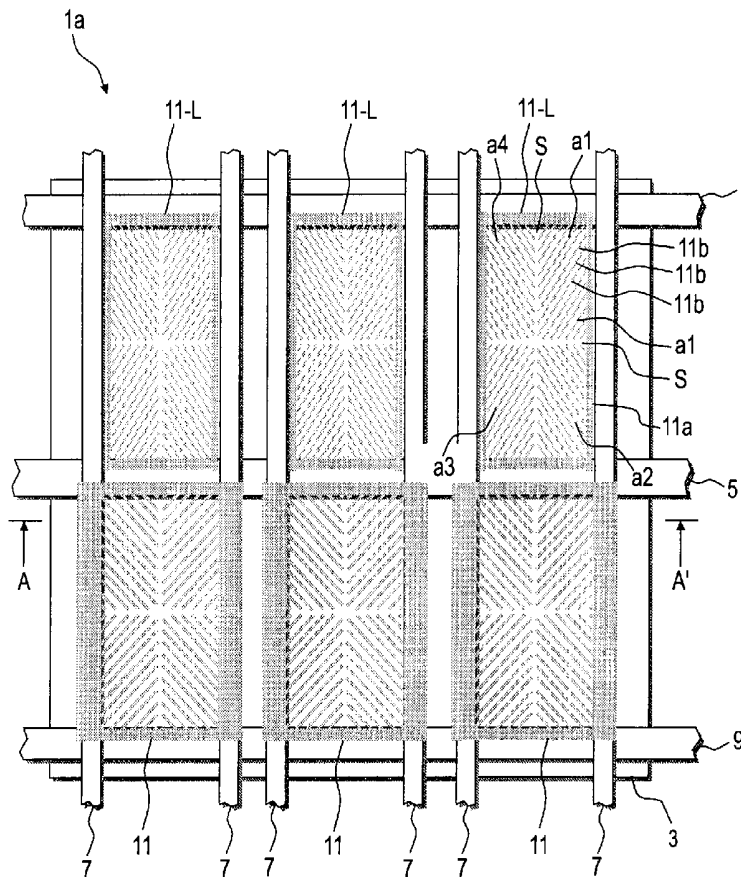

FIG. 1

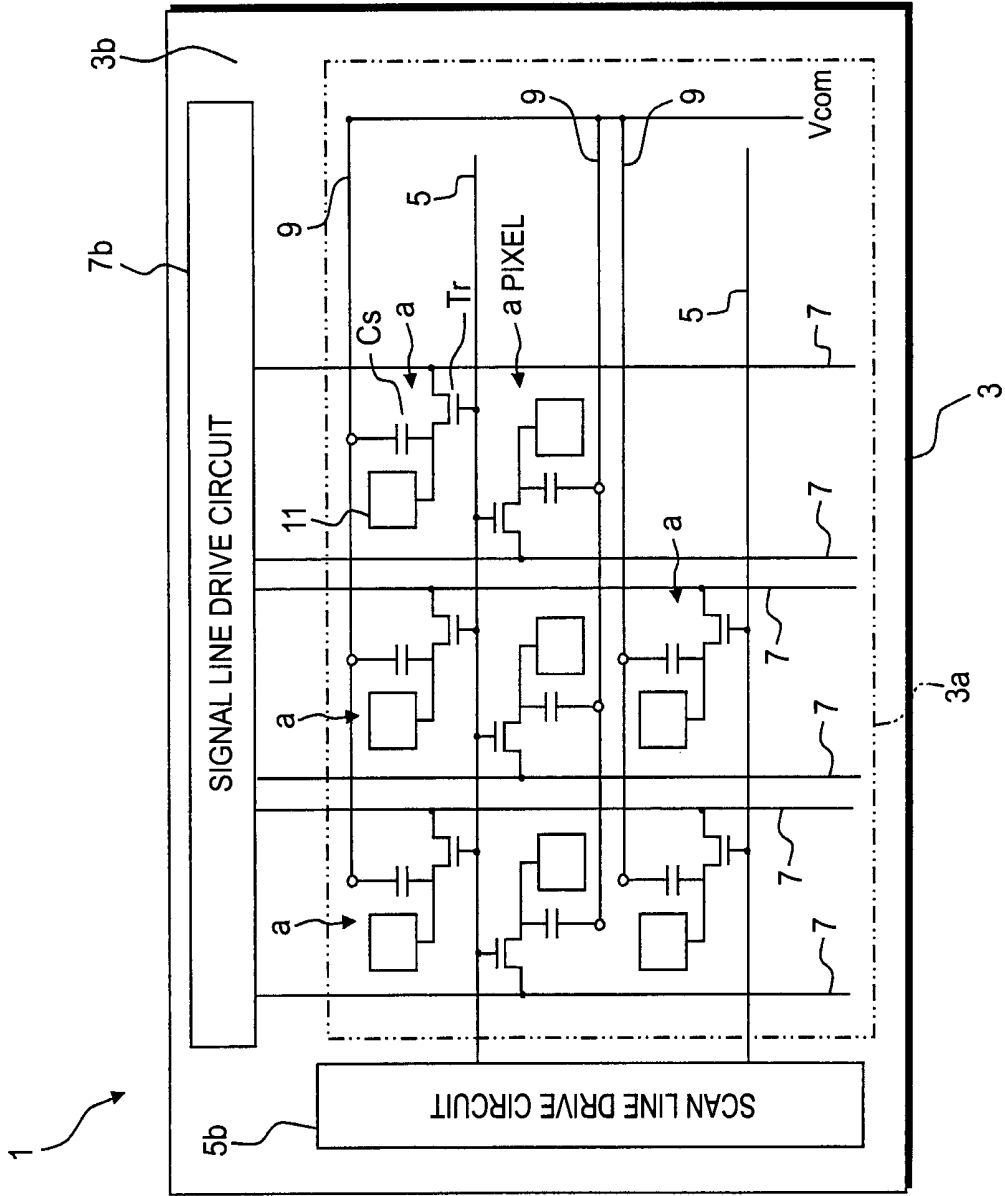

FIG. 2

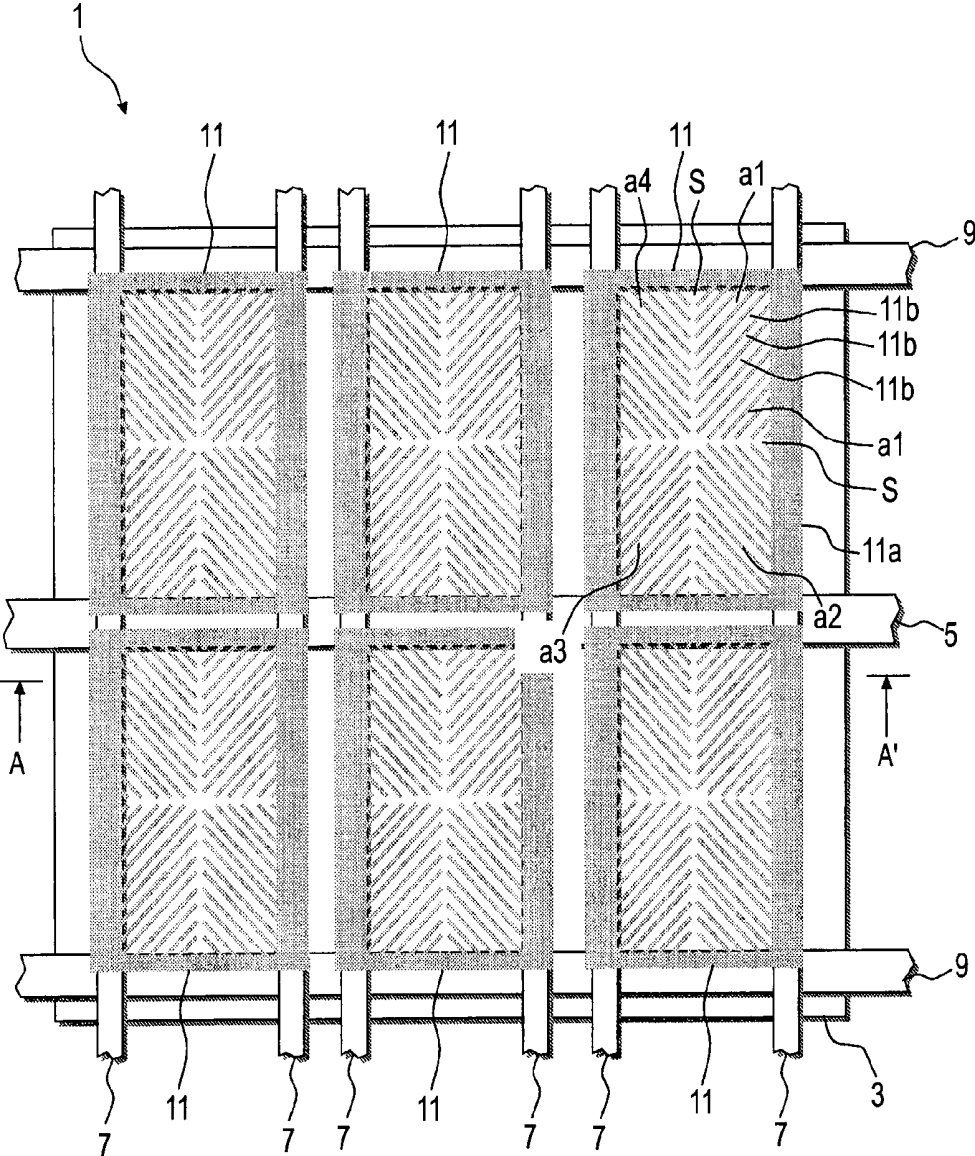

FIG. 3

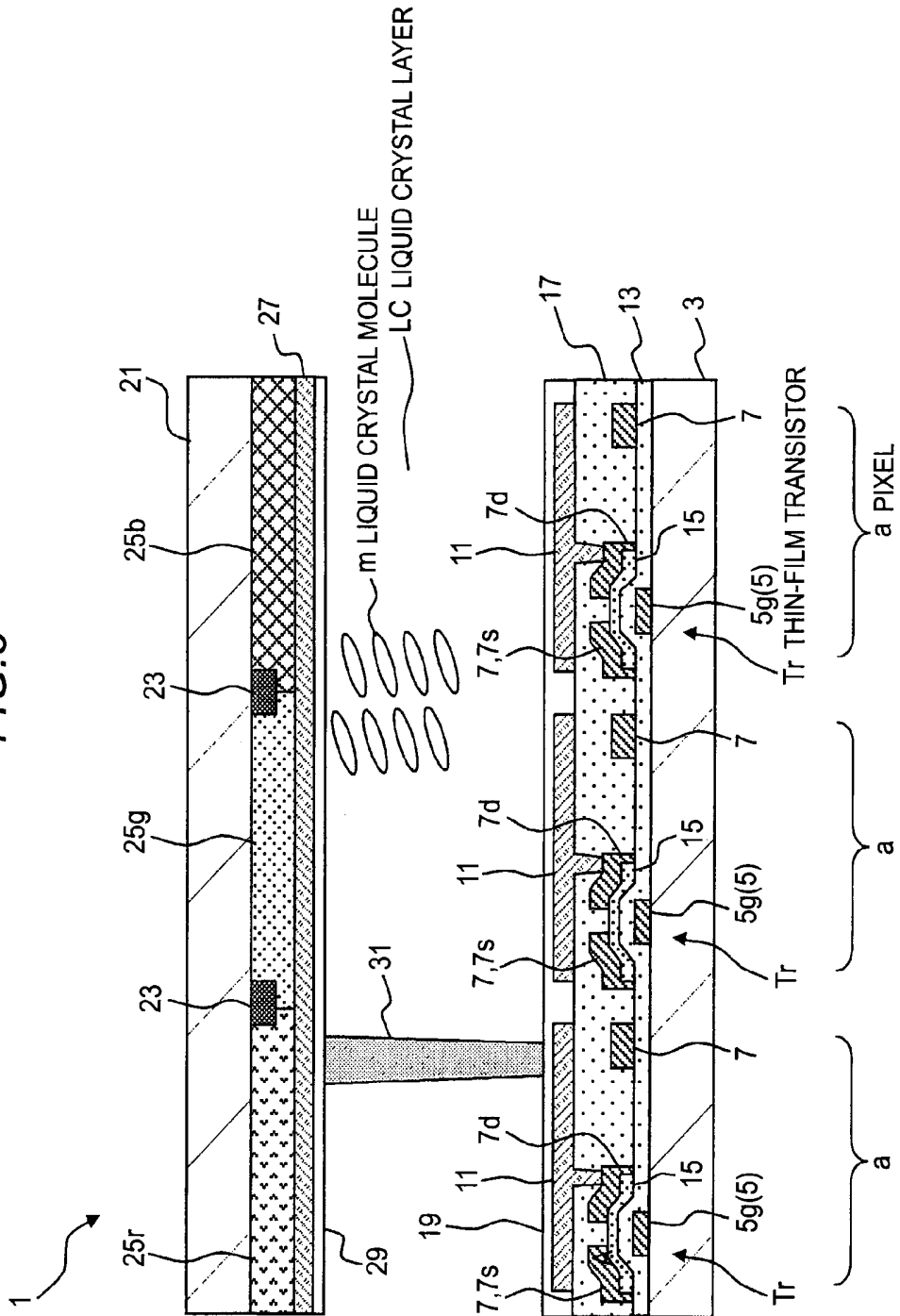

FIG.4A

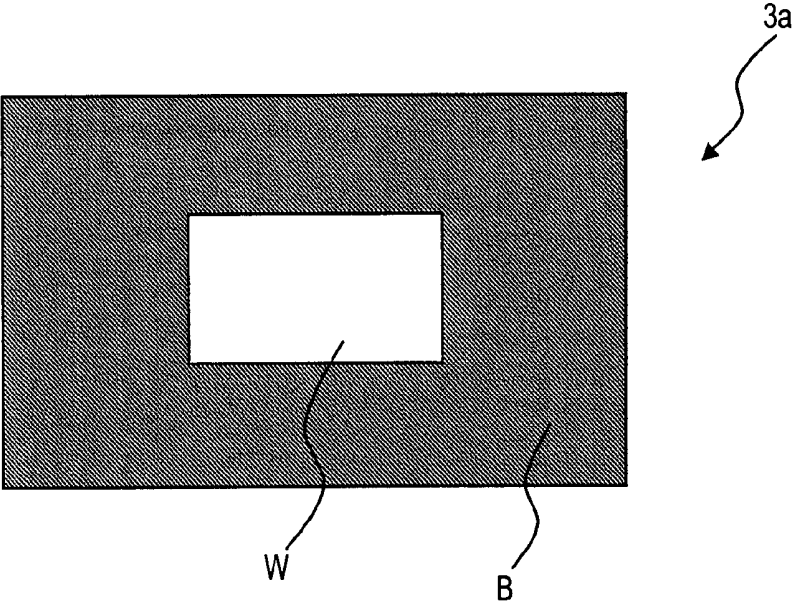

FIG.4B

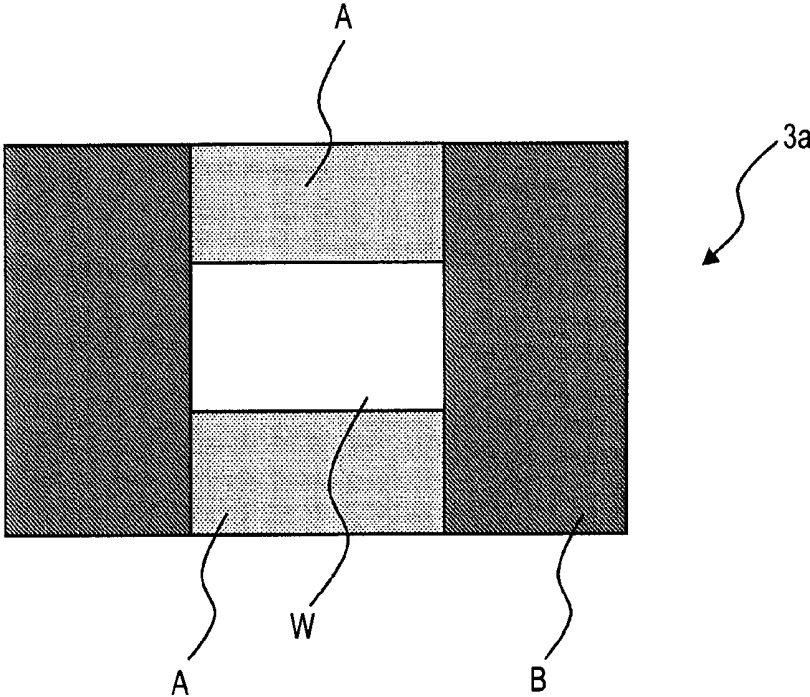

FIG. 5

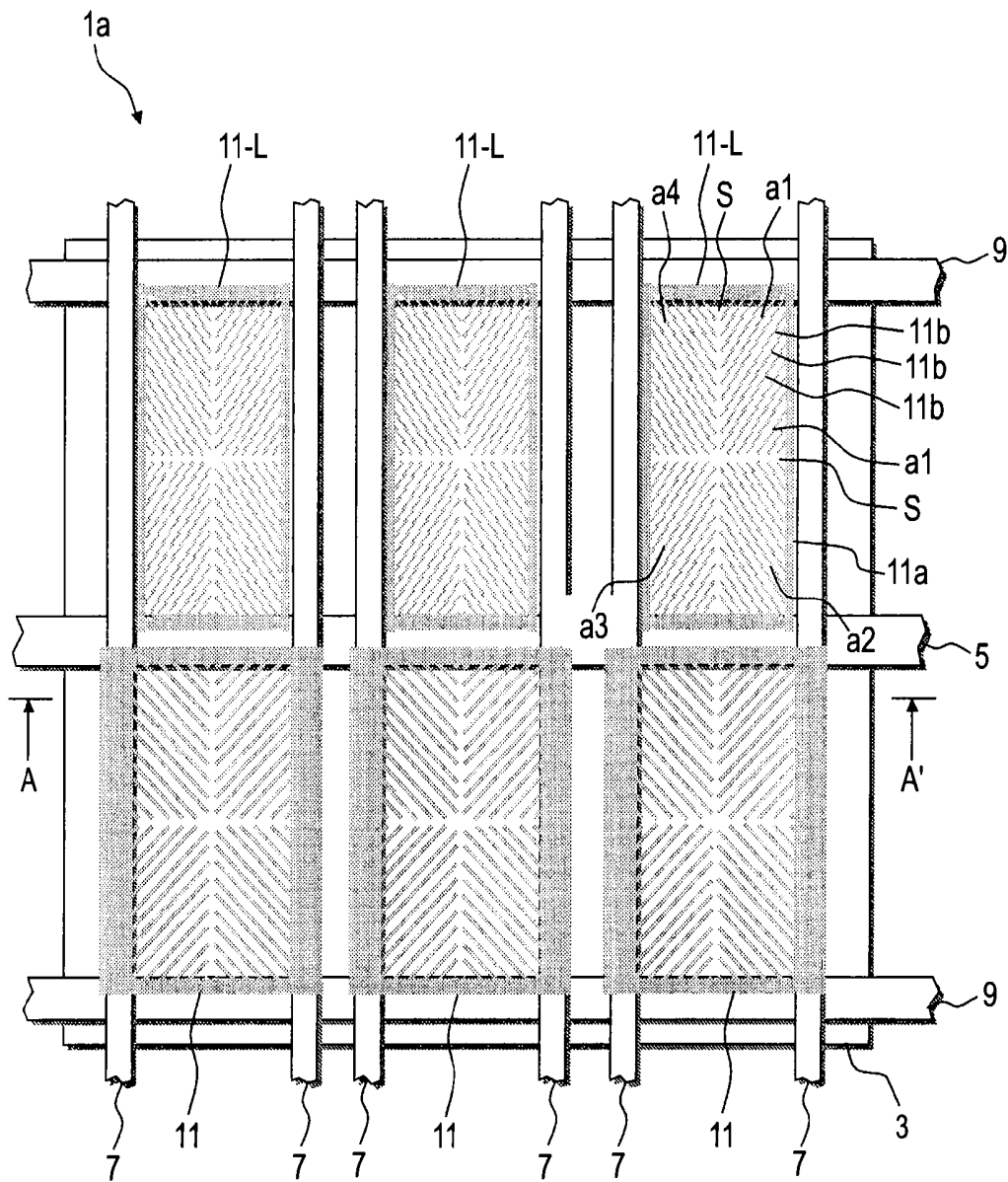

FIG. 6A

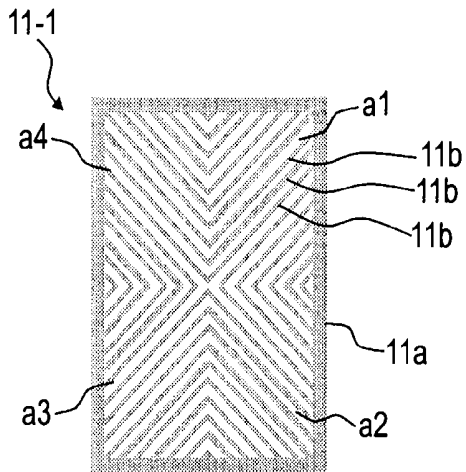

FIG. 6B

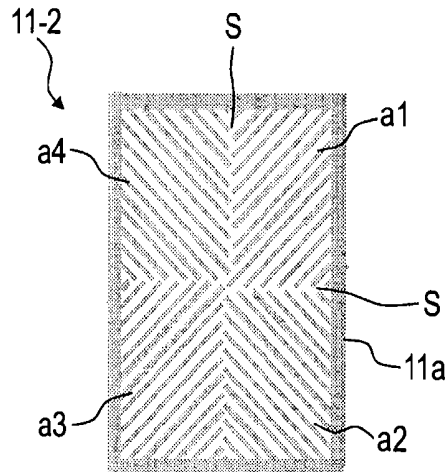

FIG. 6C

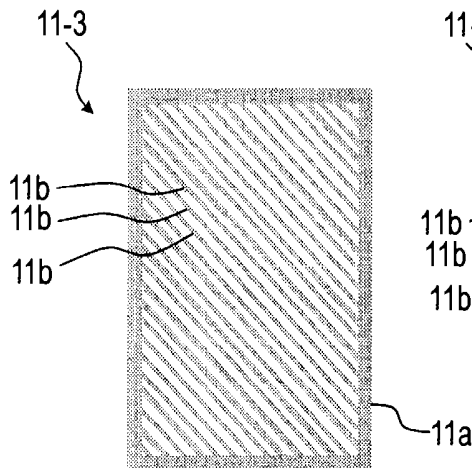

FIG. 6D

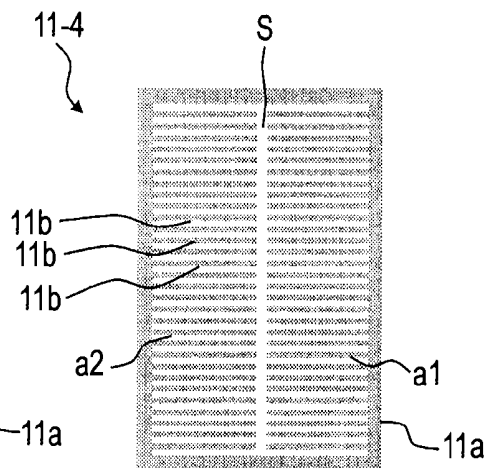

FIG. 6E

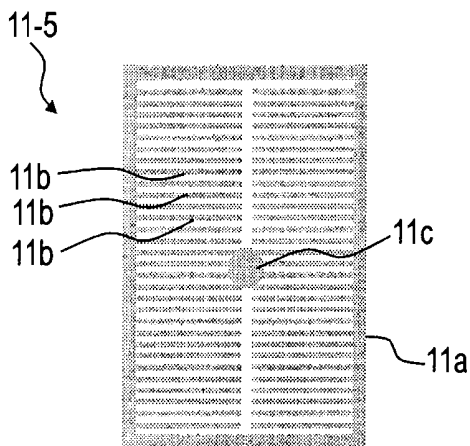

FIG. 7

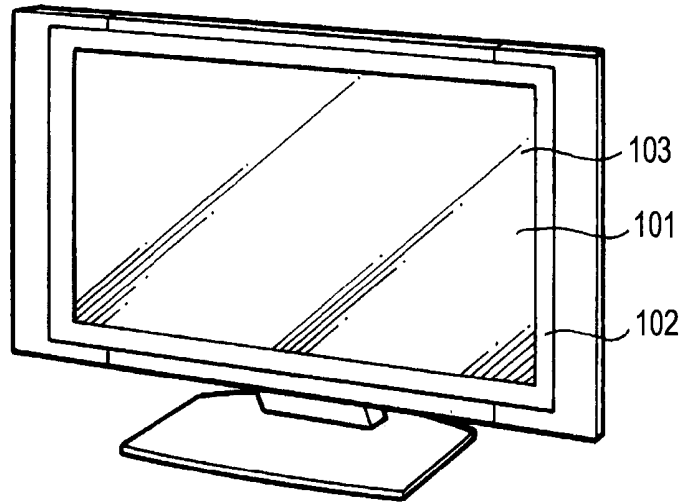

FIG. 8A

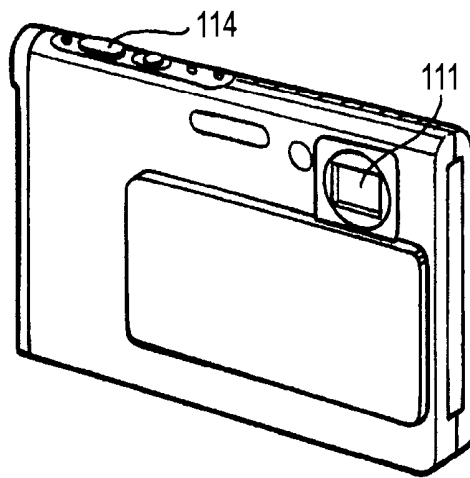

FIG. 8B

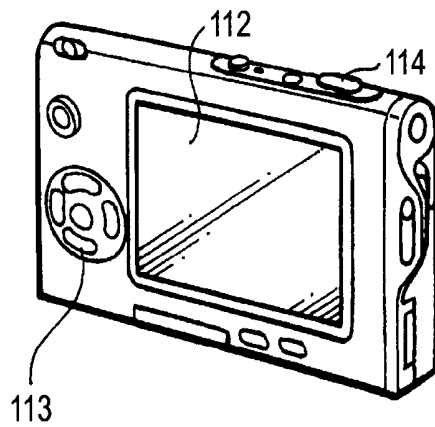

FIG.9

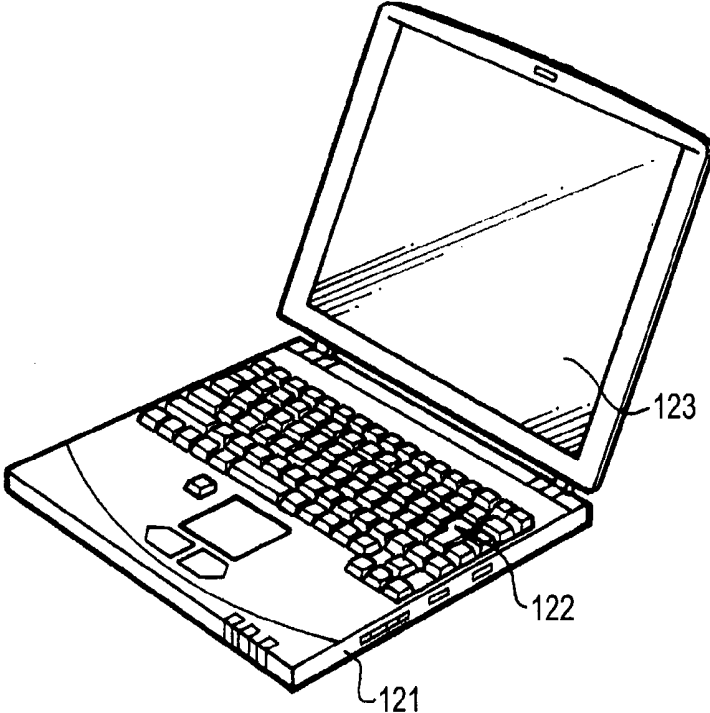

FIG.10

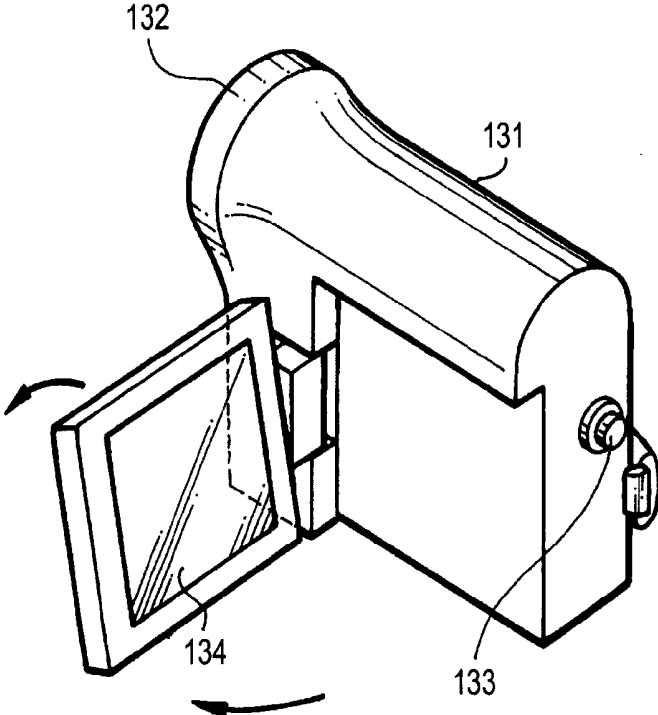

FIG. 11A FIG. 11B

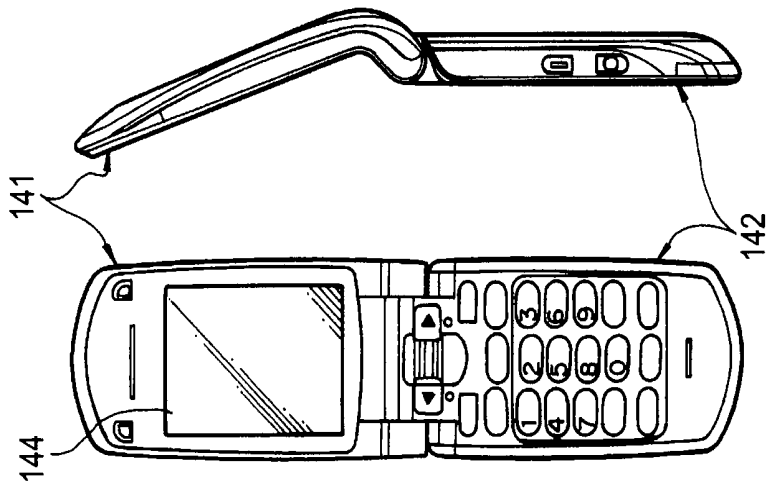

FIG. 11F

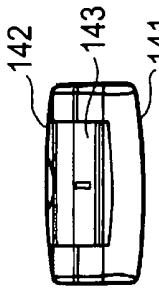

FIG. 11E

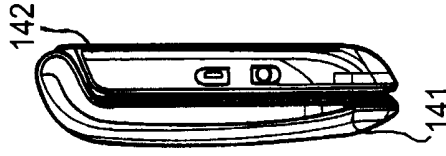

FIG. 11C

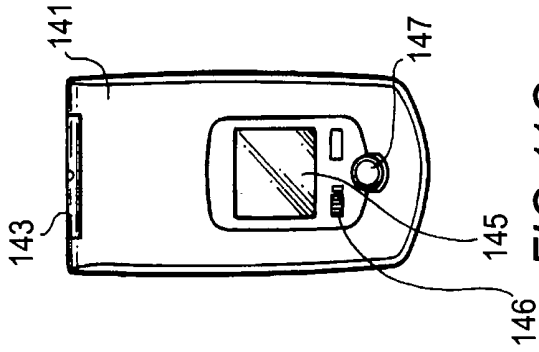

FIG. 11D

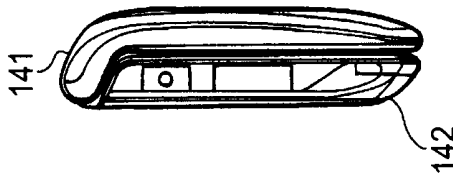

FIG. 11G



# LIQUID CRYSTAL DISPLAY DEVICE AND ELECTRONIC APPARATUS

## BACKGROUND OF THE INVENTION

### 1. Field of the Invention

The present invention relates to a liquid crystal display device and an electronic apparatus, and particularly to a liquid crystal display device including pixel electrodes, each of which has a plurality of tiny electrode bodies arranged therein, and an electronic apparatus using the liquid crystal display device as a display panel.

### 2. Description of the Related Art

As an active-matrix liquid crystal display device, a multi-domain vertically aligned mode (MVA mode) has been proposed. The MVA mode improves viewing angle characteristics by providing slits in each pixel electrode to disperse the direction in which liquid crystal molecules are inclined.

Each pixel electrode in a liquid crystal display device driven in the MVA mode is divided into four areas along boundaries, for example, the center line parallel to the horizontal direction and the center line parallel to the vertical direction. In each of the areas, slits extend along four directions from electrode bodies disposed in correspondence with the center lines perpendicular to each other, and the slits communicate with the periphery of the pixel electrode (see JP-A-2006-189610, for example, and particularly see FIGS. 1 and 3 and the corresponding description).

## SUMMARY OF THE INVENTION

In the liquid crystal display device driven in the MVA mode described above, however, signal lines, scan lines, power lines, and other bus lines are disposed in such a way that each pixel electrode overlays these bus lines. As a result, the electric field produced by the bus lines leaks through the slits and affects the orientation of the liquid crystal molecules, resulting in light leakage against a black screen or other display problems. When a white rectangle is displayed only at the center of a full black screen, in particular, the black areas above and below the white rectangle become slightly bright. This is called crosstalk and a significant problem.

Thus, it is desirable to provide a liquid crystal display device capable of preventing the orientation of liquid crystal molecules from being disturbed due to the electric field leaking through electrode members that form each pixel electrode and hence capable of preventing light from leaking and providing excellent display characteristics. It is also desirable to provide an electronic apparatus using the liquid crystal display device.

A liquid crystal display device according to an embodiment of the present invention includes a plurality of pixel electrodes and a common electrode insulated from the plurality of pixel electrodes. In particular, each of the pixel electrodes includes a frame-shaped connection electrode and electrode bodies arranged in parallel to one another in a frame of the connection electrode and supported by and connected to the connection electrode.

An electronic apparatus according to another embodiment of the invention includes a liquid crystal panel including the thus configured pixel electrodes and common electrode.

In the thus configured liquid crystal display device, since each of the pixel electrodes is formed of a plurality of electrode bodies arranged in parallel to one another, applying voltages to the pixel electrodes causes liquid crystal molecules having negative dielectric anisotropy to be aligned with and inclined in the direction in which the electrode

bodies extend. Each of the pixel electrodes includes a frame-shaped connection electrode for connecting and supporting the plurality of electrode bodies. As a result, disposing the frame-shaped connection electrode in such a way that it overlays the wiring line connected to a thin-film transistor for driving the corresponding pixel electrode allows the connection electrode to shield the wiring line and hence prevents the electric field resulting from the voltage applied to the wiring line from leaking through the slits between the electrode bodies of the pixel electrode.

Since the embodiments of the present invention described above can prevent the electric field from leaking through the slits, a liquid crystal display device having high-contrast display characteristics without liquid crystal molecule orientation disturbance due to the electric field leakage and corresponding light leakage and an electronic apparatus using the liquid crystal display device can be provided.

## BRIEF DESCRIPTION OF THE DRAWINGS

FIG. 1 shows an exemplary circuit configuration of a liquid crystal display device of an embodiment;

FIG. 2 shows an example of the layout of a liquid crystal display device 1 of a first embodiment;

FIG. 3 is a schematic cross-sectional configuration diagram corresponding to the cross section taken along the line A-A' in FIG. 2;

FIGS. 4A and 4B show images obtained by displaying in a display area an image formed of a central white rectangle against a fully black screen;

FIG. 5 shows an example of the layout of a liquid crystal display device 1a of a second embodiment;

FIGS. 6A to 6E are plan views showing variations of a pixel electrode used in the invention;

FIG. 7 is a perspective view showing a television to which the invention is applied;

FIGS. 8A and 8B show a digital camera to which the invention is applied, FIG. 8A being a front perspective view, and FIG. 8B being a rear perspective view;

FIG. 9 is a perspective view showing a notebook personal computer to which the invention is applied;

FIG. 10 is a perspective view showing a video camcorder to which the invention is applied; and

FIGS. 11A to 11G show a portable terminal to which the invention is applied, for example, a mobile phone, FIG. 11A being a front view of the mobile phone in an unfolded state, FIG. 11B being a side view of the unfolded mobile phone, FIG. 11C being a front view of the mobile phone in a folded state, FIG. 11D being a left side view of the folded mobile phone, FIG. 11E being a right side view of the folded mobile phone, FIG. 11F being a top view of the folded mobile phone, and FIG. 11G being a bottom view of the folded mobile phone.

## DESCRIPTION OF THE PREFERRED EMBODIMENTS

Embodiments of the invention will be described below in the following order.

1. First embodiment (an example in which a connection electrode that forms a pixel electrode overlays wiring lines)

2. Second embodiment (an example in which a connection electrode that forms a pixel electrode is shifted from wiring lines)

3. Variations of the embodiments (variations in the shape of the pixel electrode)

[Circuit Configuration of Liquid Crystal Display Device]

FIG. 1 shows an exemplary circuit configuration of a liquid crystal display device 1 of the present embodiment. The circuit configuration of the liquid crystal display device 1 will first be described with reference to FIG. 1.

In the liquid crystal display device 1 shown in FIG. 1, a display area 3a and a peripheral area 3b around the display area 3a are set on a substrate 3. In the display area 3a, a plurality of scan lines 5 are disposed in a first direction (the horizontal direction in the description) and a plurality of signal lines 7 are disposed in a second direction (the vertical direction in the description). Two common wiring lines 9 are further disposed in the display area 3a for each of the scan lines 5 on opposite sides thereof. A pixel a is provided in the portion surrounded by a scan line 5, a common line 9, and two signal lines 7, and the pixels 5 form a pixel array. On the other hand, in the peripheral area 3b are disposed a scan line drive circuit 5b that drives the scan lines 5 and a signal line drive circuit 7b that supplies video signals (that is, input signals) according to brightness information to the signal lines 7.

In each of the pixels (a), a pixel circuit formed of, for example, a thin-film transistor Tr as a switching element and a storage capacitor Cs is provided, and a pixel electrode 11 is connected to the pixel circuit. The pixel electrode 11 is provided on an interlayer insulating film that covers the pixel circuit, as will be described below in detail with reference to a plan view and a cross-sectional view.

In the thin-film transistor Tr, the gate electrode is connected to the corresponding scan line 5, the source electrode is connected to the corresponding signal line 7, and the drain electrode is connected to one of the electrodes of the storage capacitor Cs and the pixel electrode 11. The thin-film transistors Tr in two pixels (a) disposed on opposite sides of a scan line 5 connect their gate electrodes to the shared scan line 5. The other electrode of the capacitive element Cs is connected to the corresponding common wiring line 9. The common wiring line 9 is connected to a common electrode on the side where a counter substrate (not shown in FIG. 1) is present.

In the configuration described above, the voltage of a video signal written from the signal line 7 via the thin-film transistor Tr is supplied to the pixel electrode 11. At the same time, the same voltage is stored in the storage capacitor Cs.

The configuration of the pixel circuit described above is presented only by way of example. A capacitive element may be provided in the pixel circuit as necessary, or a plurality of transistors may form the pixel circuit as necessary. Further, in accordance with any change in the pixel circuit, a drive circuit necessary due to the change may be added to the peripheral area 3b.

[Layout of Liquid Crystal Display Device]

FIG. 2 shows an example of the layout of the liquid crystal display device 1 according to the first embodiment. The layout includes three pixels in the horizontal direction and one pixel formed of two sub-pixels in the vertical direction, three pixels in total. FIG. 3 is a schematic cross-sectional configuration diagram corresponding to the cross section taken along the line A-A' in FIG. 2. The components that are the same as those in FIG. 1 have the same reference characters.

As shown in FIGS. 2 and 3, the scan lines 5 and the common wiring lines 9 made of a material that excels in conductivity, such as aluminum, are successively disposed in the first direction (the horizontal direction in the description) in a first layer on the substrate 3 formed of, for example, a

glass substrate. A group of two common wiring lines 9 disposed on opposite sides of one scan line 5 is repeatedly disposed.

Each of the scan lines 5 extends in the horizontal direction and is patterned to form the gate electrode 5g of the thin-film transistor Tr in each of the pixels (a). Each of the common wiring lines 9 extends in the horizontal direction and functions as the lower electrode of the auxiliary capacitive element (Cs) shown in FIG. 1 in each of the pixels (a).

The scan lines 5, each of which includes the gate electrode 5g, and the common wiring lines 9 described above are covered with a gate insulating film 13, which is shown only in the cross-sectional view.

Semiconductor layers 15, each of which is an active area of the corresponding thin-film transistor Tr, are provided in a second layer on the gate insulating film 13 in the positions where the gate electrodes 5g are formed.

On the gate insulating film 13 on which the semiconductor layers 15 are provided, the signal lines 7 and the source electrodes 7s and the drain electrodes 7d of the thin-film transistors Tr are provided. Each of the source electrodes 7s is formed by extending the corresponding signal line 7 and placed on the corresponding semiconductor layer 15 in each of the pixels. The signal lines 7, the source electrodes 7s, and the drain electrodes 7d are made of a material that excels in conductivity, such as aluminum.

An insulating film 17, such as an overcoat layer (having a film thickness of 2 μm) and a planarization insulating film, shown only in the cross-sectional view is provided to cover the semiconductor layers 15, the signal lines 7, the source electrodes 7s, and the drain electrodes 7d described above.

The pixel electrodes 11 made of ITO or any other suitable transparent conductive material are formed and arranged in a third layer on the insulating film 17. Each of the pixel electrodes 11 is connected to the corresponding drain electrode 7d via a connection hole provided in the interlayer insulating film 17. The portion sandwiched between the common wiring line 9 as the lower electrode and the pixel electrode 11 located thereabove is formed as the capacitive element (Cs) shown in FIG. 1.

The first embodiment, in particular, is characterized in that each of the pixel electrodes 11 is formed of a frame-shaped connection electrode 11a and a plurality of electrode bodies 11b supported by the connection electrode 11a.

The frame-shaped connection electrode 11a is formed along the contour of the pixel electrode 11 and overlays via the insulating film (see FIG. 3) the wiring lines connected to the thin-film transistor Tr for driving the pixel electrode 11, such as the corresponding scan line 5, two signal lines 7, and common wiring line 9. The process of disposing the connection electrode 11a in such a way that it overlays the wiring lines 5, 7, and 9 is preferably carried out in such a way that the wiring lines 5, 7, and 9 are not disposed inside the connection electrode 11a. The connection electrode 11a may also be disposed in such a way that it overlays the source electrode 7s and the drain electrode 7d made of the same material as that of the signal lines 7. The connection electrode 11a preferably has a completely closed frame shape or may alternatively have a frame shape with a slit present in part thereof.

The electrode bodies 11b are arranged in the frame of the connection electrode 11a and connected to and supported by the connection electrode 11a. The electrode bodies 11b are configured as what is called a comb-tooth electrode as a whole and arranged at predetermined spacings and parallel to one another, whereby liquid crystal molecules m, which will be described later, are oriented substantially along the electrode bodies 11b.

The electrode bodies **11b** are disposed in four areas obtained by dividing the pixel electrode **11** along boundaries, the center line parallel to the horizontal direction and the center line parallel to the vertical direction, and extend in four different directions inclined to the center lines by 45 degrees. In this case, each of the electrode bodies **11b** extends in each of the areas from the inner edge of the connection electrode **11a** toward the center of the pixel electrode **11**. As a result, the pixel electrode **11** has four areas **a1**, **a2**, **a3**, and **a4** in which the respective electrode bodies **11b** extend in different directions. The four areas form a multi-domain configuration in which the liquid crystal molecules **m**, which will be described later, are oriented in four different directions.

In the four areas obtained by dividing the pixel electrode **11**, the width of the line-and-space (the electrode body **11** is defined as the line) ranges from approximately 4 to 10  $\mu\text{m}$  when the line:the space=1:1. For example, the width of the line-and-space is 8  $\mu\text{m}$ .

The electrode bodies **11b** in the four areas obtained by dividing the pixel electrode **11** are separated from each other by slits **S** provided along the center lines of the pixel electrode **11**, which are the boundaries between the areas. As a result, the slits **S** work as oriented nuclei when the liquid crystal molecules **m**, which will be described later, are oriented, whereby the orientation is stably divided.

The thus configured pixel electrode **11** is covered with an orientation film **19**. The orientation film **19** is a vertical orientation film that preferably imparts a pretilt angle for fast response. Specifically, a pretilt angle is imparted by using a PSA-based (Polymer-Sustained Alignment) method, optical orientation, mask rubbing, and any other suitable method. In the present embodiment, the orientation film **19** is preferably a vertical orientation film having a pretilt angle of 89.5 degrees or smaller and having, for example, a film thickness of approximately 0.1  $\mu\text{m}$ . Further, the azimuthal direction of the pretilt angle is inclined to the signal lines **7**, for example, by 45 degrees.

Further, a counter electrode **21** shown only in the cross-sectional view is provided over the thus configured driving substrate **3** on the side where the pixel electrodes **11** are formed. A black matrix **23** and color filters **25r**, **25g**, and **25b** are provided on the surface of the counter substrate **21** that faces the pixel electrodes **11**, and a common electrode **27** common to all the pixels is provided over the counter substrate **21**.

The black matrix **23** is disposed in such a way that it faces and covers the gaps between the pixels (a)-(a) arranged in the horizontal and vertical directions. Openings provided in the black matrix **23** substantially work as pixel openings. It is preferred that the black matrix **23** completely covers the scan lines **5**, the signal lines **7**, and the common wiring lines **9**. The color filters **25r**, **25g**, and **25b** are formed and arranged in correspondence with the pixels (a) separated by the black matrix **23**.

The common electrode **27** described above is covered with an orientation film **29**. The orientation film **29** is also a vertical orientation film that preferably imparts a pretilt angle, which is similar to the orientation film **19** on the side where the substrate **3** is present. The azimuthal direction of the pretilt angle of the orientation film **29** is antiparallel to that of the orientation film **19** on the side where the substrate **3** is present.

As shown only in the cross-sectional view, a liquid crystal layer **LC** is disposed between the orientation film **19** on the substrate **3** and the orientation film **29** on the counter substrate **21**. The liquid crystal layer **LC** contains the liquid crystal molecules **m** driven by turning the pixel electrodes **11** on and

off. The liquid crystal molecules **m** are negative liquid crystal material having negative dielectric anisotropy ( $\Delta n=0.8$ ,  $\Delta \epsilon=-3$ , for example).

The distance between the substrate **3** and the counter substrate **21**, between which the liquid crystal layer **LC** is sandwiched, is maintained at a predetermined value (cell gap), for example, by column-shaped spacers **31** interposed between the substrate **3** and the counter substrate **21**. In the present embodiment, the cell gap is adjusted in such a way that a phase difference of approximately  $\lambda/2$  ( $\lambda/4$  when the liquid crystal display device is a reflective one) is produced in the liquid crystal layer **LC** with the major axis of the liquid crystal molecules **m** oriented in parallel to the direction in which the electrode bodies **11b** extend. In this case, the cell gap is adjusted by providing the column-shaped spacers **31**, for example, made of a resist material and having a height of 4  $\mu\text{m}$ .

A pair of polarizers (not shown) in the crossed-nicol state is disposed outside the substrates **3** and **21** described above, and a backlight (not shown) is disposed outside the polarizer on the side where the substrate **3** is present. The liquid crystal display device **1** is thus configured.

In the thus configured liquid crystal display device **1** described above, the pixel electrodes **11** and the common electrode **27** face each other with the liquid crystal layer **LC** sandwiched therebetween, and a vertical electric field produced between the pixel electrodes **11** and the common electrode **27** drives the liquid crystal layer **LC**. Each of the pixel electrodes **11** is driven by the corresponding pixel circuit having the thin-film transistor **Tr**, and the corresponding scan line **5**, two signal lines **7**, and common wiring line disposed below the pixel electrode **11** via the insulating film **17** on the side where the substrate **3** is present.

The liquid crystal display device **1** of the embodiment described above is a liquid crystal display device driven in the VA-mode in which the liquid crystal molecules **m** follow the pretilt angle of the orientation films **19** and **29** when no voltage is applied to the pixel electrodes **11** and are oriented substantially perpendicular to the surface of the substrate **3**. When no electric field is applied, the light from the backlight disposed outside the substrate **3** is absorbed by the polarizer on the side where the counter substrate **21** is present, resulting in black display.

On the other hand, since each of the pixel electrodes **11** is formed of a plurality of electrode bodies **11b** disposed in parallel to each other, the liquid crystal molecules **m** having negative dielectric anisotropy are inclined in the four directions, which are the directions in which the electrode bodies **11b** extend, when a voltage is applied to the pixel electrode **11**. As a result, the liquid crystal molecules **m** are oriented in such a way that the major axis thereof is parallel to the directions in which the electrode bodies **11b** extend, and a phase difference of approximately  $\lambda/2$  is produced in the liquid crystal layer **LC**, resulting in white display. In this process, since the liquid crystal molecules **m** have a multi-domain configuration in which the molecules are oriented in the four different directions, the viewing angle characteristics are improved.

In the liquid crystal display device **1** of the first embodiment, in particular, the frame-shaped connection electrode **11a** forms the outer shape of each of the pixel electrodes **11**, and the connection electrode **11a** overlays the corresponding scan line **5**, two signal lines **7**, and common wiring line **9**. In this configuration, the connection electrode **11a** shields the wiring lines **5**, **7**, and **9** described above, whereby the electric field resulting from the voltages applied to the wiring lines **5**, **7**, and **9** will not leak through the slits between the electrode

bodies **11b** to the gap between the pixel electrodes **11** and the common electrode **27**. As a result, the vertical electric field between the pixel electrodes **11** and the common electrode **27** is well maintained, resulting in high-contrast display characteristics without liquid crystal molecule orientation disturbance due to electric field leakage and corresponding light leakage.

The thus configured liquid crystal display device **1** may be configured to carry out a display drive operation by using unit pixels each of which is formed of two pixels (a) (sub-pixels) that share one scan line **5**. In this case, two adjacent pixels (a) (sub-pixels) disposed, for example, in the direction in which the corresponding two signal lines **7** extend form one unit pixel.

In two sub-pixels (a) that form one unit pixel, the corresponding pixel electrodes **11** may have different sizes from each other. Further, the two sub-pixels may have a multi-pixel structure in which they are driven by different voltages (threshold values), and the grayscales of the sub-pixels may be adjusted separately. This allows uniform-brightness display in the front and oblique directions within the viewing angle and solves a "wash-out phenomenon," in which the brightness increases in the oblique directions within the viewing angle.

FIG. **4A** shows a result obtained by driving the thus configured liquid crystal display device **1** to display an image in the display area **3a**, the image formed of a central white rectangle **W** against a fully black screen **B**. In each of the pixel electrodes **11**, the line (electrode body **11b**):the space=4  $\mu$ m:4  $\mu$ m. The pretilt angle of each of the orientation films **19** and **29** is 89.5 degrees, and the liquid crystal layer **LC** contains negative liquid crystal molecules **m** ( $\Delta n=0.8$ ,  $\Delta \epsilon=-3$ ). The pixel electrodes **11** for two sub-pixels that form one unit pixel have the same shape and are driven by the same drive voltage. The number of pixels in the display area **3a** is 1920 $\times$ 1080, which forms a full high-vision screen.

As shown in FIG. **4A**, the display area **3a** displays the white rectangle **W** only at the center of the fully black screen **B**, and the portion around the white rectangle **W** is kept in black without any light leakage. It is thus ascertained that no crosstalk occurs and no electric field leakage occurs from the gap between the electrode bodies **11b** and **11b** of each of the pixel electrodes **11** to the gap between the pixel electrodes **11** and the common electrode **27**.

As a comparison, FIG. **4B** shows an image obtained by displaying the same image in a liquid crystal display device of related art using pixel electrodes each of which has a configuration in which no frame-shaped connection electrode is used but a plurality of electrode bodies are connected to each other at the center of the pixel electrode. As shown in FIG. **4B**, there appear gray areas **A** above and below the white rectangle **W** in which the grayscale level decreases due to crosstalk. It is therefore shown that electric field leakage to the gap between the pixel electrodes **11** and the common electrode **27** causes light leakage.

The crosstalk described above primarily results from the voltage applied to the signal lines **7**. It is therefore possible to prevent crosstalk by disposing the connection electrode **11a** of each of the pixel electrodes **11** in such a way that it overlays the corresponding two signal lines **7**, as described in the first embodiment.

## 2. Second Embodiment

FIG. **5** shows an example of the layout of characteristic portions of a liquid crystal display device **1a** according to a second embodiment. The layout includes three pixels in the

horizontal direction and one pixel formed of two sub-pixels in the vertical direction, three pixels in total. The liquid crystal display device **1a** of the second embodiment shown in FIG. **5** is similar to the display device of the first embodiment but differs therefrom in that the connection electrode **11a** of each of part of the pixel electrodes **11** does not overlay the corresponding wiring lines **5**, **7**, and **9**.

That is, the liquid crystal display device **1a** carries out a display drive operation by using unit pixels each of which is formed of two pixels (a) (sub-pixels) that share one scan line **5** and has a multi-pixel structure in which the two sub-pixels (a) are driven by different voltages (threshold values). The pixel electrode **11** provided in each of the sub-pixels (a) is the same as the pixel electrode **11** in the first embodiment and has a shape formed by the connection electrode **11a** and the electrode bodies **11b**.

In particular, the connection electrode **11a** in a pixel electrode **11-L** of one of the two pixels (a) that form a unit pixel, the one sub-pixel a driven by a lower threshold voltage, does not completely overlay at least part of the wiring lines (the corresponding two signal lines **7**, for example) but is shifted therefrom. For example, two portions of the connection electrode **11a** extending in the direction in which the signal lines **7** extend are disposed inside the corresponding signal lines **7** disposed on both side of the pixel electrode **11-L**.

In the thus configured liquid crystal display device **1a**, since the connection electrode **11a** of each of the pixel electrodes **11** overlays the corresponding wiring lines **5**, **7**, and **9**, parasitic capacitance tends to be added between the pixel electrode **11** and the wiring lines **5**, **7**, and **9**. In the sub-pixel a driven by a lower threshold voltage, in particular, the parasitic capacitance between the corresponding two signal lines **7** and the pixel electrode **11-L** adversely affects the drive operation of the pixel electrode **11-L**. In the second embodiment, however, since the portion of the connection electrode **11a** of the pixel electrode **11-L** that overlays the corresponding two signal lines **7** is small, the parasitic capacitance can be reduced. As a result, even when a multi-pixel structure is employed, the sub-pixel a driven by a lower threshold voltage can be stably driven.

<Variations>

FIGS. **6A** to **6E** are plan views showing variations of each of the pixel electrodes used in the invention.

A pixel electrode **11-1** shown in FIG. **6A** differs from the pixel electrode **11** in the first embodiment in that the electrode bodies **11b** disposed in the four areas **a1** to **a4** are connected to each other at the boundaries thereof. The configuration described above also allows high-contrast display characteristics to be provided because the connection electrode **11a** shields the corresponding wiring lines **5**, **7**, and **9**, as in the first embodiment.

A pixel electrode **11-2** shown in FIG. **6B** differs from the pixel electrode **11** in the first embodiment in that the tips of the electrode bodies **11b** disposed in the four areas **a1** to **a4** are alternately disposed along the boundaries thereof. The configuration described above also allows high-contrast display characteristics to be provided because the connection electrode **11a** shields the corresponding wiring lines **5**, **7**, and **9**, as in the first embodiment. Further, in the configuration described above, when the electrode bodies **11b** are grouped and disposed in the areas **a1** to **a4** obtained by dividing the pixel electrode **11** and the slits **S** are provided, the width of the slits **S** can be sufficiently reduced. It is therefore possible to not only use the slits **S** as oriented nuclei for the liquid crystal molecules to stably divide the orientation but also arrange the electrode bodies **11b** without any unnecessary gap in the frame of the connection electrode **11a** to effectively produce

a vertical electric field between the pixel electrodes **11** and the common electrode, whereby the white transmittance can be improved.

A pixel electrode **11-3** shown in FIG. **6C** is formed only of the electrode bodies **11b** extending in a single direction, and both ends of each of the electrode bodies **11b** are connected to the connection electrode **11a**. The electrode bodies **11b** extend in the direction inclined to, for example, the scan lines or the signal lines by 45 degrees. A liquid crystal display device provided with the thus configured pixel electrodes **11-3** has a mono-domain configuration in which the liquid crystal molecules *m* are oriented only in a single direction along the direction in which the electrode bodies **11b** extend. The configuration described above also allows high-contrast display characteristics to be provided because the connection electrode **11a** shields the corresponding wiring lines **5**, **7**, and **9**, as in the first embodiment. The direction in which the electrode bodies **11b** extend may alternatively be the direction along the scan lines or the signal lines.

A pixel electrode **11-4** shown in FIG. **6D** is formed only of the electrode bodies **11b** extending in a single direction, and only one end of each of the electrode bodies **11b** is connected to the connection electrode **11a**. A slit **S** provided in a central portion divides the pixel electrode **11-4** into two areas **a1** and **a2**. The electrode bodies **11b** extend in parallel to, for example, the scan lines. A liquid crystal display device provided with the thus configured pixel electrodes **11-4** has a multi-domain configuration in which the slit **S** works as an oriented nucleus and the liquid crystal molecules *m* are oriented in the single direction along the direction in which the electrode bodies **11b** extend. The configuration described above also allows high-contrast display characteristics to be provided because the connection electrode **11a** shields the corresponding wiring lines **5**, **7**, and **9**, as in the first embodiment. The direction in which the electrode bodies **11b** extend may be the direction along the signal lines or the direction inclined to the scan lines or the signal lines by 45 degrees.

A pixel electrode **11-5** shown in FIG. **6E** has a configuration in which a pad **11c** for connecting the pixel electrode **11-5** to the drain electrode of the corresponding thin-film transistor is provided at the center of the pixel electrode **11-4** shown in FIG. **6D**. The pad **11c** is supported by the connection electrode **11a** via a plurality of electrode bodies **11b**. The configuration described above also allows high-contrast display characteristics to be provided because the connection electrode **11a** shields the corresponding wiring lines **5**, **7**, and **9**, as in the first embodiment. Further, the pad **11c** may also be used as an oriented nucleus for the liquid crystal molecules to stably divide the orientation. In this case, the pad **11c** is preferably disposed at the center of the pixel electrode **11**. The position in which the pad **11c** is provided is not limited to the center of the pixel electrode **11-5**, but may be anywhere in the pixel electrode **11-5**. For example, the pad **11c** may be provided in a position where it is directly supported by the connection electrode **11a**. The pad **11c** may be provided in the same manner in any of the pixel electrodes described in the above embodiments and variations.

#### <Applications>

Any of the liquid crystal display devices according to the embodiments of the invention described above can be used as a display panel in a display section of a variety of electronic apparatus shown in FIGS. **7** to **11G**. For example, any of the liquid crystal display devices can be used in a display section of an electronic apparatus in any field in which a video signal inputted to the electronic apparatus or a video signal produced in the electronic apparatus is displayed as an image, such as digital cameras, notebook personal computers,

mobile phones or other portable terminals, and video camcorders. Exemplary electronic apparatus to which the invention is applied will be described below.

FIG. **7** is a perspective view showing a television to which the invention is applied. The television according to the present application includes a video display screen **101** formed of a front panel **102**, a filter glass plate **103**, and other components, and the video display screen **101** is produced by using any of the display devices according to the embodiments of the invention.

FIGS. **8A** and **8B** show a digital camera to which the invention is applied. FIG. **8A** is a front perspective view, and FIG. **8B** is a rear perspective view. The digital camera according to the present application includes a flash light emitter **111**, a display section **112**, a menu switch **113**, and a shutter button **114**, and the display section **112** is produced by using any of the display devices according to the embodiments of the invention.

FIG. **9** is a perspective view showing a notebook personal computer to which the invention is applied. The notebook personal computer according to the present application includes a body **121**, a keyboard **122** operated when characters and other information are inputted, a display section **123** on which an image is displayed, and the display section **123** is produced by using any of the display devices according to the embodiments of the invention.

FIG. **10** is a perspective view showing a video camcorder to which the invention is applied. The video camcorder according to the present application includes a body **131**, a subject imaging lens **132** provided on the side facing frontward, a start/stop switch **133** used when video images are captured, and a display section **134**, and the display section **134** is produced by using any of the display devices according to the embodiments of the invention.

FIGS. **11A** to **11G** show a portable terminal to which the invention is applied, for example, a mobile phone. FIG. **11A** is a front view of the mobile phone in an unfolded state. FIG. **11B** is a side view of the unfolded mobile phone. FIG. **11C** is a front view of the mobile phone in a folded state. FIG. **11D** is a left side view of the folded mobile phone. FIG. **11E** is a right side view of the folded mobile phone. FIG. **11F** is a top view of the folded mobile phone. FIG. **11G** is a bottom view of the folded mobile phone. The mobile phone according to the present application includes an upper housing **141**, a lower housing **142**, a connection unit (a hinge in the present application) **143**, a display **144**, a sub-display **145**, a picture light **146**, and a camera **147**, and the display **144** and the sub-display **145** are produced by using any of the display devices according to the embodiments of the invention.

The present application contains subject matter related to that disclosed in Japanese Priority Patent Application JP 2009-009524 filed in the Japan Patent Office on Jan. 20, 2009, the entire contents of which are hereby incorporated by reference.

It should be understood by those skilled in the art that various modifications, combinations, sub-combinations and alterations may occur depending on design requirements and other factors insofar as they are within the scope of the appended claims or the equivalents thereof.

What is claimed is:

1. A liquid crystal display device comprising:
  - a plurality of pixel electrodes formed of a frame-shaped connection electrode and electrode bodies arranged in parallel to one another in a frame of the connection electrode and supported by and connected to the connection electrode; and

11

a common electrode insulated from the plurality of pixel electrodes,  
 wherein a plurality of pixels formed of adjacent ones of the plurality of pixel electrodes form one unit pixel, and wherein the plurality of pixels that form a unit pixel are driven at different threshold values,  
 a wiring line connected to a thin-film transistor for driving each of the plurality of pixel electrodes and disposed via an insulating film in such a way that the wiring line and the common electrode sandwich each of the plurality of pixel electrodes,  
 wherein among the plurality of pixels, the connection electrode of a corresponding pixel electrode in a pixel driven at a low threshold value is disposed in a position where the connection electrode is shifted from at least part of the wiring line.

2. The liquid crystal display device according to claim 1, further comprising a wiring line connected to a thin-film transistor for driving each of the plurality of pixel electrodes and disposed via an insulating film in such a way that the wiring line and the common electrode sandwich each of the plurality of pixel electrodes,  
 wherein the connection electrode of the plurality of pixel electrodes overlays the wiring line.

3. The liquid crystal display device according to claim 2, wherein the wiring line is a signal line.

4. The liquid crystal display device according to any of claims 1 to 3,  
 further comprising a liquid crystal layer between a substrate on which the plurality of pixel electrodes are arranged and a counter substrate on which the common electrode is provided.

5. The liquid crystal display device according to any of claims 1 to 3,  
 wherein each of the plurality of pixel electrodes has a plurality of areas in which the electrode bodies extend in respective different directions.

12

6. The liquid crystal display device according to claim 5, wherein a slit is provided between the plurality of areas.

7. The liquid crystal display device according to any of claims 1 to 3,  
 wherein liquid crystal molecules driven by the plurality of pixel electrodes have negative dielectric anisotropy.

8. The liquid crystal display device according to claim 7, wherein an orientation film that covers the plurality of pixel electrodes has a pretilt angle of 89.5 degrees or smaller.

9. An electronic apparatus comprising:  
 a display panel including  
 a plurality of pixel electrodes formed of a frame-shaped connection electrode and electrode bodies arranged in parallel to one another in a frame of the connection electrode and supported by and connected to the connection electrode, and  
 a common electrode insulated from the plurality of pixel electrodes,  
 wherein a plurality of pixels formed of adjacent ones of the plurality of pixel electrodes form one unit pixel, and  
 wherein the plurality of pixels that form a unit pixel are driven at different threshold values,  
 a wiring line connected to a thin-film transistor for driving each of the plurality of pixel electrodes and disposed via an insulating film in such a way that the wiring line and the common electrode sandwich each of the plurality of pixel electrodes,  
 wherein among the plurality of pixels, the connection electrode of a corresponding pixel electrode in a pixel driven at a low threshold value is disposed in a position where the connection electrode is shifted from at least part of the wiring line.

\* \* \* \* \*

专利名称(译)	液晶显示装置和电子设备		
公开(公告)号	<a href="#">US8467026</a>	公开(公告)日	2013-06-18
申请号	US12/651030	申请日	2009-12-31
[标]申请(专利权)人(译)	井上有一 OGAWA RYO SUWA俊一		
申请(专利权)人(译)	井上有一 OGAWA RYO SUWA俊一		
当前申请(专利权)人(译)	索尼公司		
[标]发明人	INOUE YUICHI OGAWA RYO SUWA SHUNICHI		
发明人	INOUE, YUICHI OGAWA, RYO SUWA, SHUNICHI		
IPC分类号	G02F1/1343		
CPC分类号	G02F1/133707 G02F1/134336		
优先权	2009009524 2009-01-20 JP		
其他公开文献	US20100182521A1		
外部链接	<a href="#">Espacenet</a> <a href="#">USPTO</a>		

摘要(译)

一种液晶显示装置，包括：多个像素电极，由框形连接电极和电极体形成，所述多个像素电极在所述连接电极的框架中彼此平行布置，并由所述连接电极支撑并连接到所述连接电极；以及与多个像素电极绝缘的公共电极。

