



US006762805B2

(12) **United States Patent**  
**Ishino**

(10) **Patent No.:** **US 6,762,805 B2**  
(45) **Date of Patent:** **Jul. 13, 2004**

(54) **ACTIVE MATRIX TYPE LIQUID CRYSTAL DISPLAY DEVICE AND METHOD OF FABRICATING THE SAME**

5,414,547 A	*	5/1995	Matsuo et al.	349/44
5,686,977 A	*	11/1997	Kim et al.	349/38
5,986,723 A	*	11/1999	Nakamura et al.	349/39
6,008,874 A	*	12/1999	Kouno et al.	349/123
6,249,325 B1	*	6/2001	Ohkawara et al.	349/38

(75) Inventor: **Takayuki Ishino, Izami (JP)**

(73) Assignee: **NEC LCD Technologies, Ltd., Kanagawa (JP)**

(\*) Notice: Subject to any disclaimer, the term of this patent is extended or adjusted under 35 U.S.C. 154(b) by 70 days.

**FOREIGN PATENT DOCUMENTS**

JP	06-082832	3/1994
JP	08-262495	10/1996
JP	10-239678	9/1998
JP	11-119253	4/1999

\* cited by examiner

(21) Appl. No.: **10/163,612**

*Primary Examiner*—Kenneth Parker

(22) Filed: **Jun. 7, 2002**

(74) *Attorney, Agent, or Firm*—Foley & Lardner LLP

(65) **Prior Publication Data**

US 2002/0196382 A1 Dec. 26, 2002

(30) **Foreign Application Priority Data**

Jun. 8, 2001 (JP) ..... 2001-173578

(51) **Int. Cl.**<sup>7</sup> ..... **G02F 1/136; G02F 1/1345**

(52) **U.S. Cl.** ..... **349/46; 349/143**

(58) **Field of Search** ..... **349/43, 44, 46, 349/111, 143**

(56) **References Cited**

**U.S. PATENT DOCUMENTS**

4,857,907 A	*	8/1989	Koden	349/140
5,345,324 A	*	9/1994	Koseki et al.	349/44

(57) **ABSTRACT**

An active matrix type liquid crystal display device includes (a) a transparent substrate, (b) a plurality of scanning lines formed on the transparent substrate, (c) a plurality of signal lines formed on the transparent substrate perpendicularly to the scanning lines, (d) a transparent electrode arranged in a pixel area defined by the scanning and signal lines, and (e) a thin film transistor formed in association with the transparent electrode, the thin film transistor being formed in an area at which one of the scanning lines and one of the signal lines intersect with each other, the thin film transistor including source and drain regions both comprised of an electrically conductive film of which the signal lines are comprised.

**20 Claims, 10 Drawing Sheets**

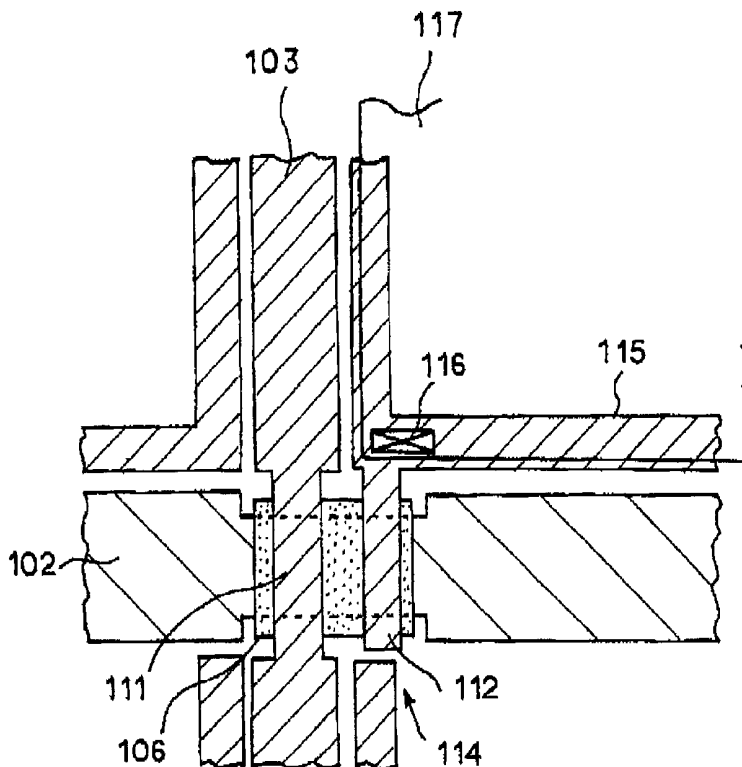



FIG. 2

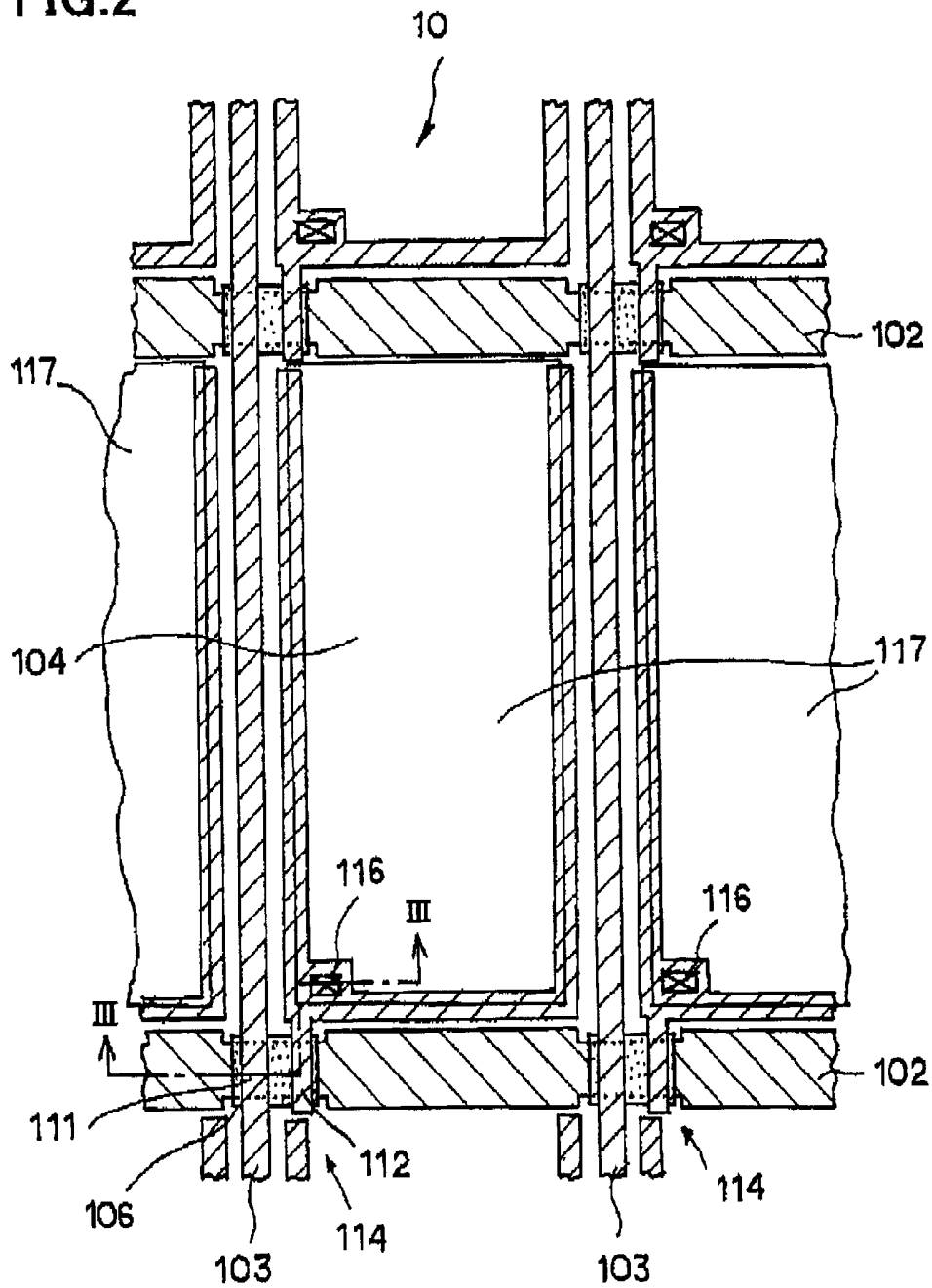

FIG. 3

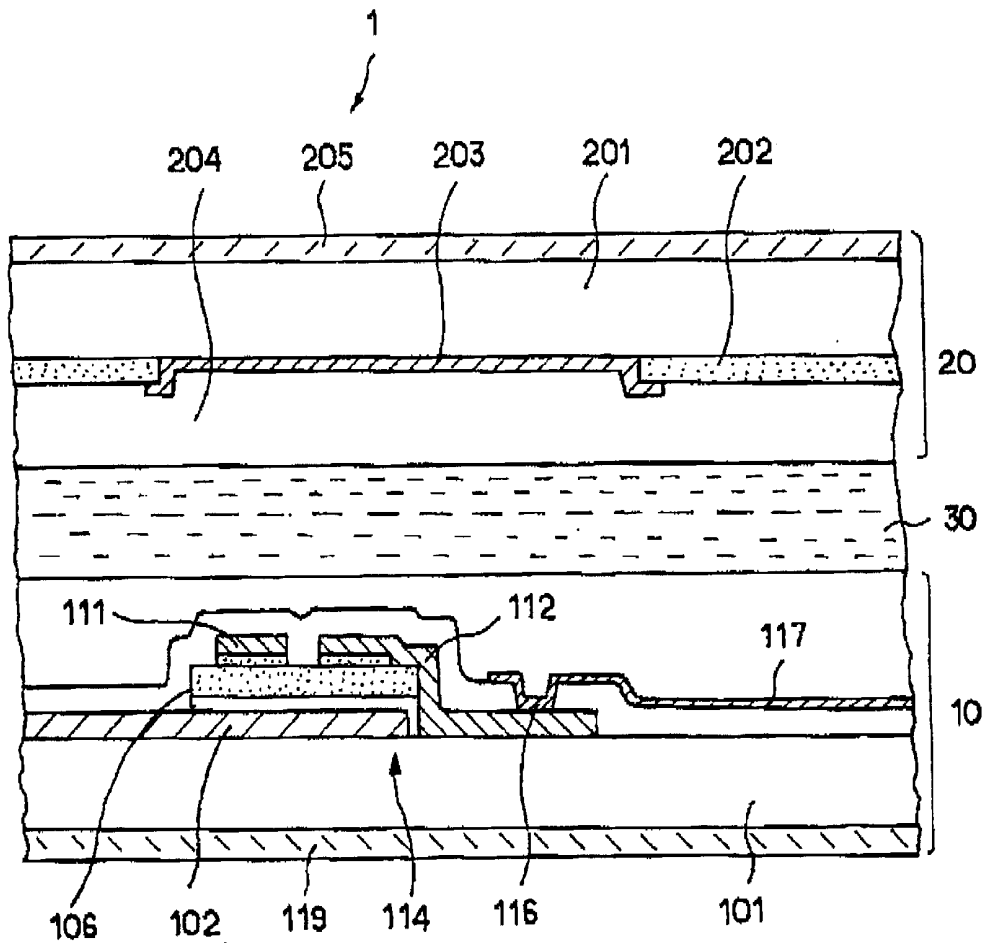



FIG. 5

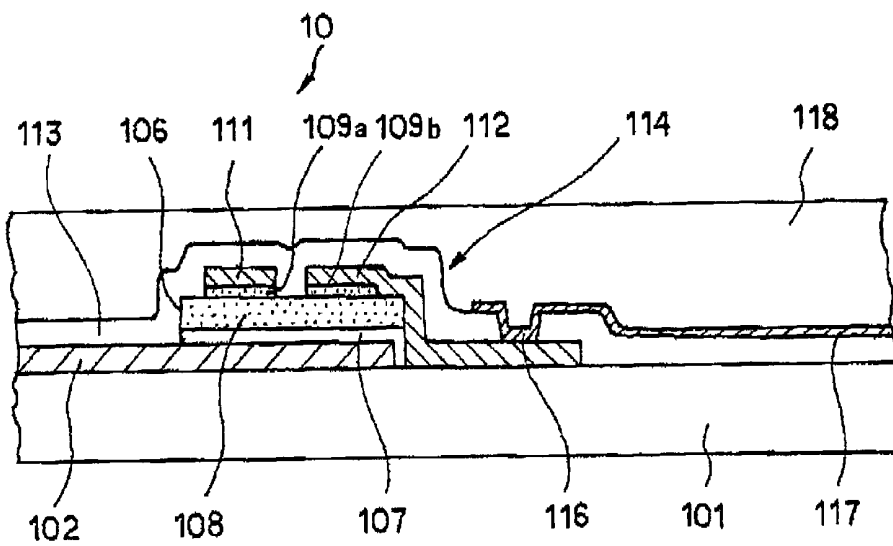

FIG. 6A

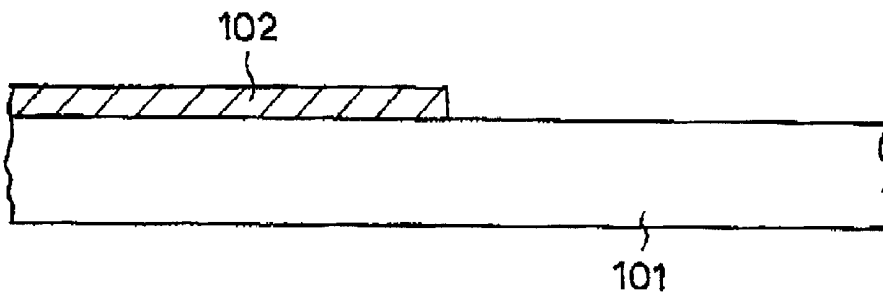

FIG. 6B

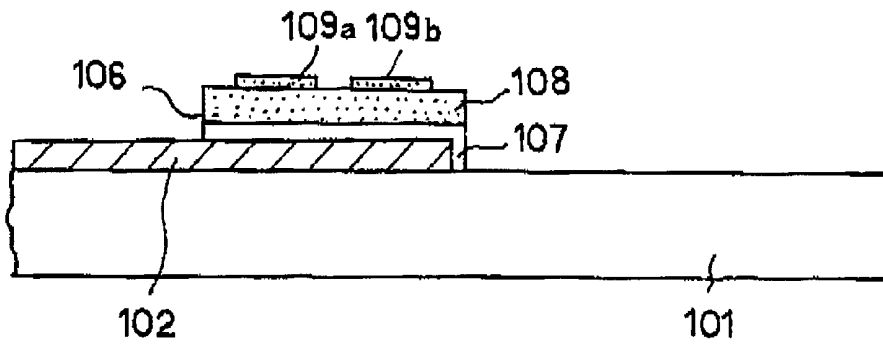

FIG. 6C

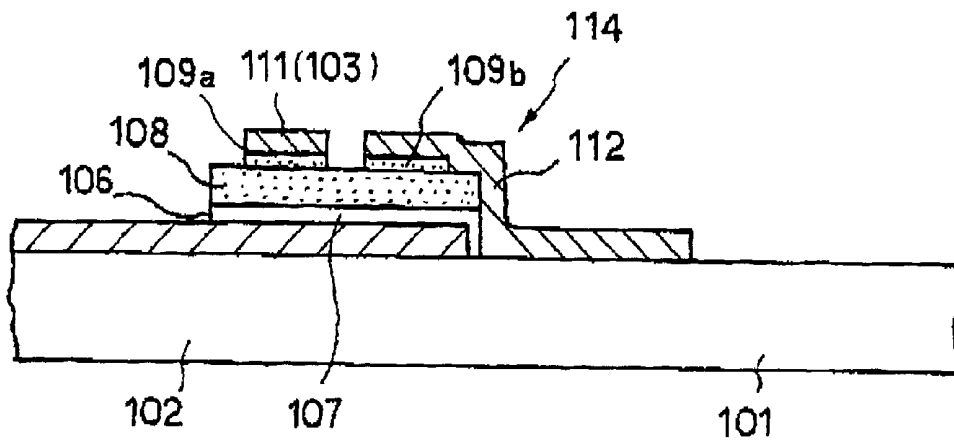

FIG. 6D

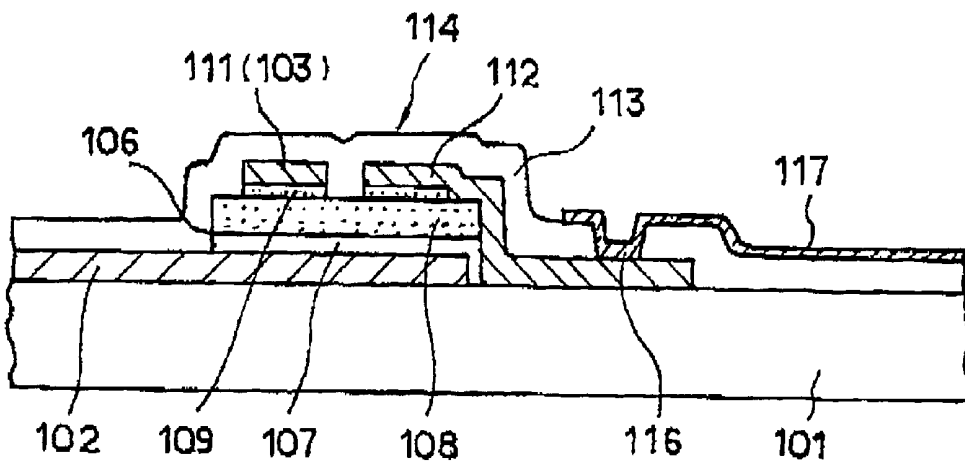

FIG. 7

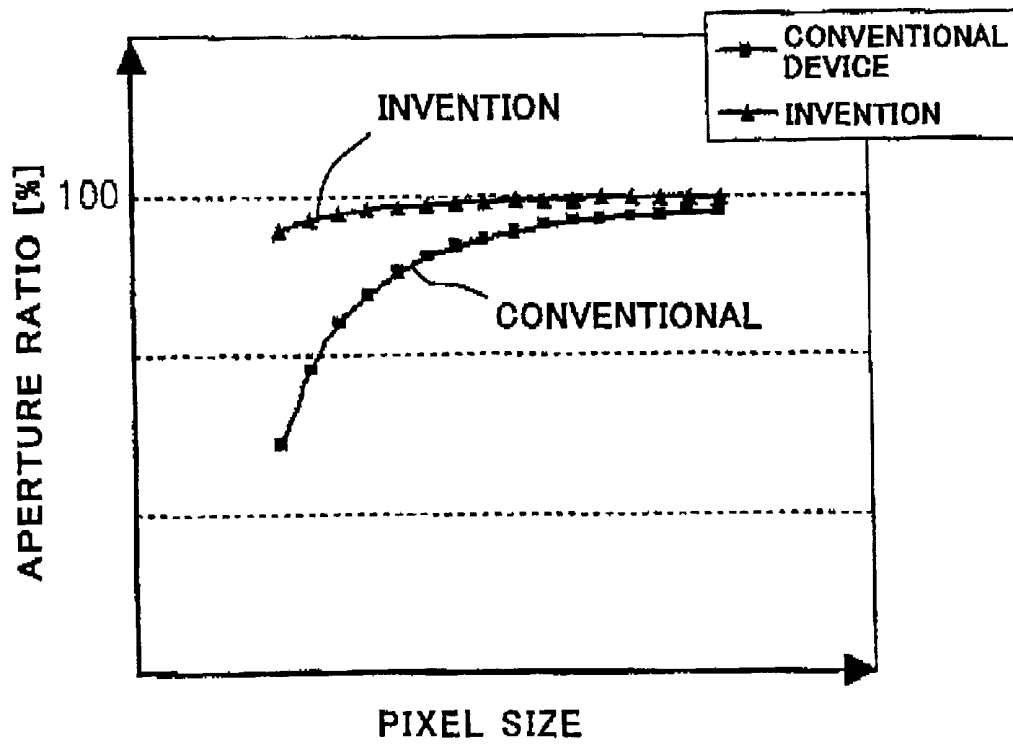

FIG. 8

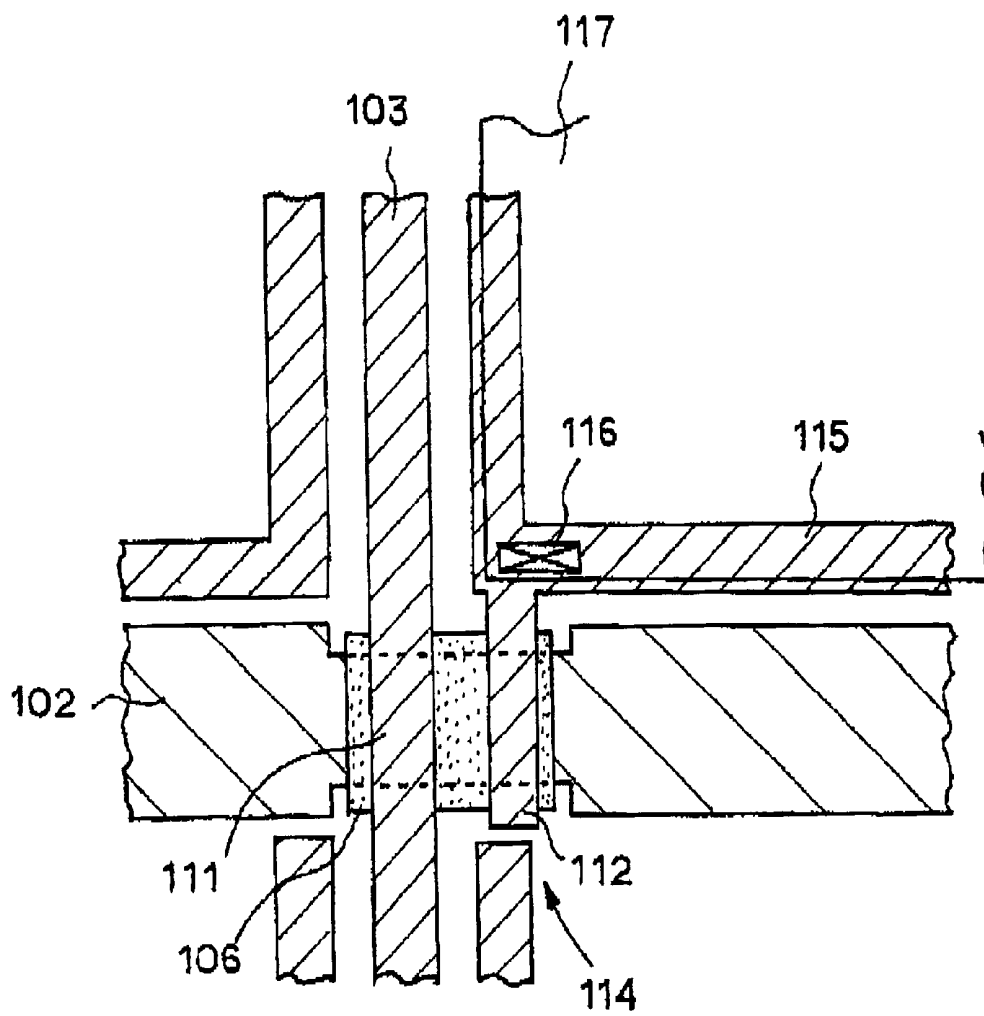
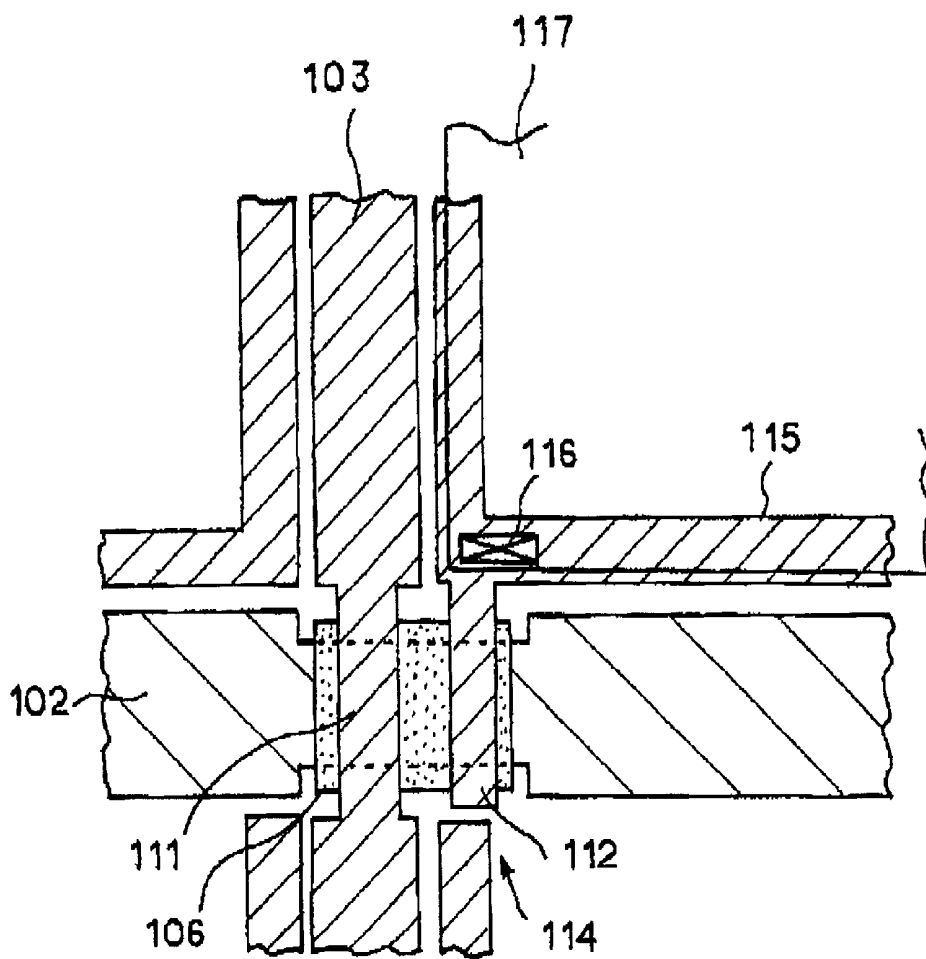

FIG. 9



# ACTIVE MATRIX TYPE LIQUID CRYSTAL DISPLAY DEVICE AND METHOD OF FABRICATING THE SAME

## BACKGROUND OF THE INVENTION

### 1. Field of the Invention

The invention relates to an active matrix type liquid crystal display device and a method of fabricating the same, and more particularly to an active matrix type liquid crystal display device which is capable of enhancing an aperture ratio and displaying images with high brightness without an increase in complexity in fabrication, and a method of fabricating such an active matrix type liquid crystal display device.

### 2. Description of the Related Art

In an active matrix type liquid crystal display device including a backlight source, a backlight intensity is usually enhanced for displaying images with a high brightness. However, this would consume much power, which does not satisfy small power consumption which is required in any display device.

In order to enhance a brightness in a liquid crystal display device including a backlight source, it is frequently carried out to enhance a light-transmission ratio. However, enhancement of a light-transmission ratio in a liquid crystal display device is equivalent to enhancement of a transmission ratio in a color filter which contributes to reduction in a light-transmission ratio. In order to enhance a transmission ratio in a color filter, a content ratio of pigment in a color filter is usually reduced, or a thickness of a color filter is reduced with a content ratio of pigment being kept as it is. However, if a transmission ratio in a color filter is enhanced by doing so, it would be necessary to control a color of backlight.

For the above-mentioned reason, it is usually carried out to enhance an aperture ratio of an opening in a substrate on which a thin film transistor is fabricated, in order to enhance a light-transmission ratio of a liquid crystal display device. Specifically, an area of each of pixels arranged in an opening is increased by reducing a wiring width and/or a size of a transistor, for instance.

FIG. 1 is a top plan view of a TFT substrate in a conventional liquid crystal display device including a backlight device.

In the illustrated liquid crystal display device, a plurality of scanning lines or gate lines **502** and a plurality of signal lines and drain lines **503** are formed on a transparent substrate in a matrix perpendicularly to each other. An area surrounded by each of the scanning lines **502** and each of the signal lines **503** defines a pixel area **504**.

A gate electrode **505** is formed of a portion of each of the scanning lines **502** at a corner of the pixel area **504**. On the gate electrode **505** is formed an island **506** comprised of a semiconductor layer, and on the island are formed a drain electrode **511** and a source electrode **512**. The gate electrode **505**, the island **506**, the drain electrode **511** and the source electrode **512** constitute a thin film transistor (TFT) **514**.

A transparent electrode **517** composed of indium tin oxide (ITO) is formed in the pixel area **504**. The source electrode **512** is electrically connected to the transparent electrode **517** through a contact hole **516**. The drain electrode **511** is formed integral with one of the signal lines **503**.

The scanning lines **502**, the signal lines **503** and the thin film transistor **514** are covered with a black matrix layer formed on an opposing substrate (not illustrated). An area other than the black matrix layer defines an aperture.

With reference to FIG. 1, a pixel area theoretically separated in a substrate on which the thin film transistor **514** is fabricated, specifically, a pixel area defined by a dotted line X is defined as a maximum aperture, and an area in which images are displayed by means of the transparent electrode **514**, specifically, an area defined by a dotted line Y is defined as an actual aperture. An aperture ratio in the illustrated liquid crystal display device is defined as a ratio of an area of the actual aperture to an area of the maximum aperture, that is, Y/X.

Hence, in order to increase an aperture ratio without changing a size of each of the pixel areas used for displaying images, a width of wirings such as the scanning and signal lines **502** and **503** covered with the black matrix layer may be reduced. However, this causes an increase in a resistance of the wirings, preventing a high-rate operation of a liquid crystal display device.

If the thin film transistor **514** and the contact hole **516** were reduced in size without changing a size of a pixel area, characteristics of the thin film transistor **514** would be deteriorated with the result of degradation in displayed images. Thus, it is quite difficult to increase an aperture ratio merely by reducing a size of wirings and/or the thin film transistor **514**.

With reduction in a size of a pixel in accordance with a requirement to displaying images at a higher density, a ratio of wirings and/or a thin film transistor to a maximum aperture becomes greater, resulting reduction in an aperture ratio. That is, displaying image at a high density causes reduction in a maximum aperture.

However, a size of wirings and a thin film transistor reaches its lower limitation. As a result, only an area of an actual aperture is reduced, and resultingly, an aperture ratio defined as a ratio of an area of the actual aperture to an area of the maximum aperture (Y/X) is reduced. Even so, if wirings, a thin film transistor and a contact hole were reduced in size in accordance with reduction in the maximum aperture, an aperture ratio remains unchanged. However, as mentioned earlier, a resistance of wirings would be increased, and characteristics of a thin film transistor would be deteriorated.

Japanese Unexamined Patent Publication No. 8-262495 (A) has suggested a liquid crystal display device for the purpose of enhancing an aperture ratio.

In the suggested liquid crystal display device, a thin film transistor is arranged in an area at which a scanning line or a gate line and a signal line or a drain line intersect with each other. By arranging a thin film transistor in such an area, it is no longer necessary to arrange a thin film transistor in a maximum aperture, ensuring enhancement of an aperture ratio.

In the suggested liquid crystal display device, a semiconductor layer such as an amorphous silicon layer is formed on a scanning line in the above-mentioned area, and then, source and drain electrodes are formed on the semiconductor layer to thereby fabricate a thin film transistor. Then, a signal line is formed so as to cover the thin film transistor therewith, and subsequently, a drain electrode is electrically connected to the signal line.

Thus, a process of fabricating the suggested liquid crystal display device includes two photolithography steps, that is, a first photolithography step of forming source and drain electrode, and a second photolithography step of forming a signal line.

In a conventional process of fabricating a liquid crystal display device, a photolithography step is carried out only

once, because source and drain electrodes are formed concurrently with formation of a signal line. Thus, a process of fabricating the suggested liquid crystal display device has to carry out a photolithography step once greater than a conventional process of fabricating a liquid crystal display device, resulting in complexity in fabrication of a liquid crystal display device.

Japanese Unexamined Patent Publication No. 6-82832 (A) has suggested a liquid crystal display device including a TFT substrate comprised of an electrically insulating substrate, a plurality of gate lines formed on the substrate, a plurality of signal lines formed on the substrate perpendicularly to the gate lines, a plurality of thin film transistors, and pixel electrodes. Each of the gate lines is comprised of a gate wiring layer formed in a recess formed at a surface of the substrate.

Japanese Unexamined Patent Publication No. 10-239678 (A) has suggested a thin film transistor array substrate including an electrically insulating transparent substrate, a plurality of gate electrode lines formed on the substrate, a gate insulating film covering the gate electrode lines therewith, a plurality of source electrode lines intersecting with the gate electrode lines with the gate insulating film being sandwiched therebetween, a thin film transistor formed at an intersection of each of the gate electrode lines and each of the source electrode lines, a pixel electrode comprised of an electrically conductive film and electrically connected to a drain electrode of the thin film transistor, a capacitance electrode facing the pixel electrode with the gate insulating film being sandwiched therebetween to thereby define a capacity, and a black matrix layer formed below the pixel electrode and each of the source electrode lines and above the substrate. The black matrix layer is composed of the same material as a material of which the gate electrode lines are composed. The black matrix layer is electrically connected to the source electrode lines through a contact hole formed throughout the gate insulating film.

Japanese Unexamined Patent Publication No. 11-119253 (A) has suggested an active matrix type liquid crystal display device including a substrate, a plurality of scanning lines formed on the substrate, a plurality of signal lines formed on the substrate perpendicularly to the scanning lines, and a switching device fabricated in the vicinity of an intersection at which the scanning lines intersect with the signal lines. A pixel electrode is electrically connected to a drain electrode of the switching device. Each of the scanning lines is formed with apertures at opposite sides about each of the signal lines in the intersection. The apertures are covered with an electrically insulating film. Each of the apertures is covered with a part of the switching device or each of the signal lines.

However, the above-mentioned problems remain unsolved even in the above-mentioned Publications.

### SUMMARY OF THE INVENTION

In view of the above-mentioned problems in the conventional liquid crystal display devices, it is an object of the present invention to provide an active matrix type liquid crystal display device which is capable of enhancing an aperture ratio without an increase in complexity in fabrication of the same.

It is also an object of the present invention to provide a method of fabricating such an active matrix type liquid crystal display device.

In one aspect of the present invention, there is provided an active matrix type liquid crystal display device including (a)

a transparent substrate, (b) a plurality of scanning lines formed on the transparent substrate, (c) a plurality of signal lines formed on the transparent substrate perpendicularly to the scanning lines, (d) a transparent electrode arranged in a pixel area defined by the scanning and signal lines, and (e) a thin film transistor formed in association with the transparent electrode, and wherein the thin film transistor is formed in an area at which one of the scanning lines and one of the signal lines intersect with each other, and the thin film transistor includes source and drain regions both comprised of an electrically conductive film of which the signal lines are comprised.

For instance, the thin film transistor may be comprised of (e1) an island including a gate insulating film and a semiconductor layer both formed on each of the scanning lines in the area at which one of the scanning lines and one of the signal lines intersect with each other, (e2) a drain electrode comprised of a part of each of the signal lines which part extends across the island, and (e3) a source electrode comprised of an electrically conductive film of which each of the signal lines is comprised, and formed on the island with being spaced away from the drain electrode.

It is preferable that the active matrix type liquid crystal display device further includes a light-shielding layer surrounding the transparent electrode and being connected to the source electrode, the light-shielding layer being formed with a contact hole through which the source electrode is electrically connected to the transparent electrode.

It is preferable that the light-shielding layer has a portion having an increased width, the contact hole being formed at the portion. As an alternative, the light-shielding layer may have a uniform width, in which case, it is preferable that the contact hole has a rectangular cross-section having a longer side extending in a length-wise direction of the light-shielding layer.

It is preferable that each of the scanning lines has a portion having a decreased width in the area at which one of the scanning lines and one of the signal lines intersect with each other, the portion acting as a gate electrode of the thin film transistor.

It is preferable that the active matrix type liquid crystal display device further includes an island formed on each of the scanning lines at the portion having a decreased width, the island including a gate insulating film and a semiconductor layer both of which is greater in width than the portion.

It is preferable that the active matrix type liquid crystal display device further includes a first ohmic layer and a second ohmic layer both formed on the semiconductor layer such that the first and second ohmic layers are spaced away from each other, the first ohmic layer being formed as an extension of each of the signal lines and acting as a drain electrode of the thin film transistor, the second ohmic layer acting as a source electrode of the thin film transistor.

It is preferable that each of the signal lines has a portion having a decreased width in the area at which one of the scanning lines and one of the signal lines intersect with each other, the portion acting as a drain electrode of the thin film transistor.

In another aspect of the present invention, there is provided a method of fabricating an active matrix type liquid crystal display device, including the steps of (a) forming a plurality of scanning lines on a transparent substrate, (b) forming an island in an area at which one of the scanning lines and one of later mentioned signal lines intersect with each other, the island including a gate insulating film, a

semiconductor layer and an ohmic layer all formed on each of the scanning lines in this order, (c) forming a plurality of signal lines extending perpendicularly to the scanning lines, each of the signal lines including a portion located on the island and acting as a drain electrode, (d) forming a source electrode on the island such that the source electrode faces and is spaced away from the drain electrode, (e) forming an interlayer insulating film entirely over a resultant resulted from the step (d), (f) forming a contact hole so that the source electrode partially appears, (g) forming a transparent electrode in a pixel area defined by the scanning and signal lines, and (g) electrically connecting the transparent electrode to the source electrode through the contact hole.

For instance, the steps (c) and (d) may be concurrently carried out.

It is preferable that each of the signal lines and the source electrode are concurrently formed in a common photolithography step.

It is preferable that the method further includes the step of forming a light-shielding layer which surrounds the transparent electrode and is connected to the source electrode, the light-shielding layer being formed with the contact hole.

It is preferable that the light-shielding layer is formed to have a portion having an increased width, the contact hole being formed at the portion.

It is preferable that the light-shielding layer is formed to have a uniform width, and the contact hole is formed to have a rectangular cross-section having a longer side extending in a length-wise direction of the light-shielding layer.

It is preferable that each of the scanning lines is formed to have a portion having a decreased width in the area at which one of the scanning lines and one of the signal lines intersect with each other, the portion acting as a gate electrode.

It is preferable that the island is formed on each of the scanning lines at the portion having a decreased width, the gate insulating film and the semiconductor layer both being greater in width than the portion.

It is preferable that the method further includes the step of forming a first ohmic layer and a second ohmic layer both on the semiconductor layer such that the first and second ohmic layers are spaced away from each other, the first ohmic layer being formed as an extension of each of the signal lines and acting as the drain electrode, the second ohmic layer acting as the source electrode.

It is preferable that each of the signal lines is formed to have a portion having a decreased width in the area at which one of the scanning lines and one of the signal lines intersect with each other, the portion acting as the drain electrode.

The advantages obtained by the aforementioned present invention will be described hereinbelow.

In accordance with the present invention, an island of a thin film transistor is formed in an area at which a scanning line and a signal line intersect with each other. As a result, it is no longer necessary to arrange a thin film transistor in a pixel area defined by a scanning line and a signal line. Since only a contact hole is formed in a pixel area for electrically connecting a source electrode and a transparent electrode to each other, it would be possible to prevent an area of a pixel area, that is, an area of a transparent electrode from being reduced by a thin film transistor, ensuring enhancement of an aperture ratio.

In accordance with the present invention, it is possible to form both of a source electrode and a signal line as a drain electrode in a common step of carrying out photolithography

to an electrically conductive film. Thus, it is possible to reduce the number of steps of carrying out photolithography by once in comparison with a conventional method of fabricating a liquid crystal display device in which source/drain electrodes and a signal line are formed in separate photolithography steps. As a result, a process of fabricating the liquid crystal display device can be simplified.

The above and other objects and advantageous features of the present invention will be made apparent from the following description made with reference to the accompanying drawings, in which like reference characters designate the same or similar parts throughout the drawings.

#### BRIEF DESCRIPTION OF THE DRAWINGS

FIG. 1 is a top plan view of a TFT substrate in a conventional liquid crystal display device including a backlight device.

FIG. 2 is a top plan view of a TFT substrate in a liquid crystal display device in accordance with the first embodiment of the present invention.

FIG. 3 is a cross-sectional view taken along the line III—III in FIG. 2.

FIG. 4 is a partially enlarged view of a thin film transistor illustrated in FIG. 2.

FIG. 5 is a cross-sectional view taken along the line V—V in FIG. 4.

FIGS. 6A to 6D are cross-sectional views of a liquid crystal display device in accordance with the first embodiment, illustrating respective steps of a method of fabricating the same.

FIG. 7 is a graph showing a relation between a pixel size and an aperture ratio in both of a conventional liquid crystal display device and a liquid crystal display device in accordance with the first embodiment.

FIG. 8 is a partially enlarged view of a thin film transistor in a liquid crystal display device in accordance with the second embodiment of the present invention.

FIG. 9 is a partially enlarged view of a thin film transistor in a liquid crystal display device in accordance with the third embodiment of the present invention.

#### DESCRIPTION OF THE PREFERRED EMBODIMENTS

Preferred embodiments in accordance with the present invention will be explained hereinbelow with reference to drawings.

[First Embodiment]

FIG. 2 is a top plan view of a TFT substrate **10** in a liquid crystal display device in accordance with the first embodiment of the present invention, and FIG. 3 is a cross-sectional view of a liquid crystal display device **1** including the TFT substrate **10**, that is, a cross-sectional view taken along the line III—III in FIG. 2.

With reference to FIG. 3, the liquid crystal display device **1** in accordance with the first embodiment is comprised of a TFT substrate **10**, an opposing substrate **20**, and a liquid crystal layer **30** sandwiched between the TFT substrate **10** and the opposing substrate **20**.

With reference to FIGS. 2 and 3, the TFT substrate **10** includes a transparent glass substrate **101**, a plurality of scanning lines or gate lines **102** formed at a surface of the glass substrate **101**, extending in a column direction, and a plurality of signal lines or drain lines **103** formed at a surface of the glass substrate **101**, extending in a row direction, that is, extending perpendicularly to the scanning lines **102**. Each

of the scanning lines **102** is composed of titanium (Ti), for instance, and is spaced away from adjacent ones by a predetermined distance. Each of the signal lines **103** is composed of chromium (Cr), for instance, and is spaced away from adjacent ones by a predetermined distance. A rectangular area surrounded by each one of the scanning lines **102** and each one of the signal lines **103** defines a pixel area **104**.

FIG. **4** is a partially enlarged view of a thin film transistor illustrated in FIG. **2**, and FIG. **5** is a cross-sectional view taken along the line V—V in FIG. **4**.

As illustrated best in FIG. **4**, the scanning line **102** is designed to have a portion having a reduced width in an area at which the scanning line **102** and the signal line **103** intersect with each other. The portion having a reduced width act as a gate electrode **105** of a later mentioned thin film transistor **114**.

As illustrated in FIG. **5**, an island **106** is formed on the gate electrode **105**. The island **106** is comprised of a gate insulating film **107** formed on the gate electrode **105**, an amorphous silicon layer **108** formed on the gate insulating film **107**, and ohmic layers **109a** and **109b** both formed on the amorphous silicon layer **108**. The gate insulating film **107**, the amorphous silicon layer **108** and the ohmic layers **109a** and **109b** have a predetermined pattern, and have a width slightly greater than a width of the gate electrode **105**. The ohmic layers **109a** and **109b** both composed of n+ amorphous silicon are slightly spaced away from each other, and act as source and drain regions of the thin film transistor **114**.

An extension of the signal line **103** is formed on the ohmic layer **109a**, and defines a drain electrode **111**. Similarly, a source electrode **112** is formed on the ohmic layer **109b**.

As illustrated in FIG. **5**, the scanning line **102**, the island **106**, the drain electrode **111** and the source electrode **112** are covered with an interlayer insulating film **113** to thereby define the thin film transistor **114**.

The source electrode **112** is comprised of a metal film of which the drain electrode **111** or the signal line **103** is composed. As illustrated in FIG. **4**, the source electrode **112** is connected at an end thereof with a light-shielding layer **115** formed along a periphery of the pixel area **104** in the form of “?”.

As illustrated in FIGS. **2** to **5**, the source electrode **112** is a transparent electrode **117** composed of indium tin oxide (ITO) is formed on the interlayer insulating film **113** in the pixel area **104**. As illustrated best in FIG. **4**, the source electrode **112** is electrically connected to the transparent electrode **117** through a contact hole **116** formed throughout the interlayer insulating film **113**.

An alignment film **118** is formed on both the interlayer insulating film **113** and the transparent electrode **117**. A polarizer **119** is formed on the glass substrate **101** at the opposite side of the scanning line **102**.

As illustrated in FIG. **16**, the opposing substrate **20** arranged in facing relation with the TFT substrate **10** is comprised of a transparent glass substrate **201**, a color filter **202** formed on the glass substrate **201**, a black matrix layer **203** formed on the glass substrate **201**, an alignment film **204** formed covering the color filter **202** and the black matrix layer **203** therewith, and a polarizer **205** formed on the glass substrate **201** at the opposite side of the black matrix layer **203**.

Spacers (not illustrated) are sandwiched between the TFT substrate **10** and the opposing substrate **20** for ensuring a gap therebetween. Liquid crystal is introduced into the gap to thereby form the liquid crystal layer **30**. The TFT substrate

**10** and the opposing substrate **20** are sealed at their periphery to prevent the liquid crystal from leaking out.

FIGS. **6A** to **6D** illustrate respective steps of a method of fabricating the TFT substrate **10**. Hereinbelow is explained a method of fabricating the TFT substrate **10**, with reference to FIGS. **6A** to **6D**.

First, as illustrated in FIG. **6A**, titanium (Ti) is deposited on the glass substrate **101** by sputtering, and then, patterned into the scanning line **102** by the first photolithography and etching.

Then, a silicon nitride (SiN) film as the gate insulating film **107**, the amorphous silicon film **108** and an n+ amorphous silicon film **109** are formed successively on the scanning line **102** by chemical vapor deposition. Then, as illustrated in FIG. **6B**, the gate insulating film **107**, the amorphous silicon film **108** and the n+ amorphous silicon film **109** are patterned into the island **106** by the second photolithography and etching.

Then, the n+ amorphous silicon film **109** is patterned into the ohmic layers **109a** and **109b** by the third photolithography and etching.

If a mask used in the second photolithography is designed to have a first portion for a channel region which first portion has a thickness smaller than a thickness of a second portion for source and drain regions, it would be possible to pattern the films **107** to **109** into the island **106** and further pattern the n+ amorphous silicon film **109** into the ohmic layers **109a** and **109b** only by the second photolithography.

Then, chromium (Cr) is deposited entirely over a resultant by sputtering. Then, the chromium is patterned into the signal line **103** by the fourth photolithography and etching, as illustrated in FIG. **6C**. A part of the signal line **103** defines the drain electrode **111**. The source electrode **112** is formed concurrently with the formation of the signal line **103**. Thus, the drain electrode **111** comprised of a part of the signal line **103** and the source electrode **112** are arranged on the ohmic layers **109a** and **109b**, respectively. Thus, there is completed the thin film transistor **114**.

As illustrated in FIG. **4**, the source electrode **112** is connected to the light-shielding layer **115** extending along a periphery of the pixel area **104** in the form of “?”.

A rectangular area **120** at which the source electrode **112** is connected to the light-shielding layer **115** is designed to have an increased width or an enlarged area for forming the contact hole **116** therein.

Then, silicon nitride is deposited by chemical vapor deposition, and subsequently, patterned into the interlayer insulating film **113**, as illustrated in FIG. **6D**.

Then, the contact hole **116** is formed throughout the interlayer insulating film **118** by the fifth photolithography and etching so as to partially expose the source electrode **112**.

Then, indium tin oxide (ITO) is deposited by sputtering, and subsequently, patterned into the transparent electrode **117** in the pixel area **104** by the sixth photolithography and etching. The transparent electrode **117** is electrically connected to the source electrode **112** through the contact hole **116**.

Thereafter, though not illustrated, the alignment film **118** is formed all over a resultant, and the polarizer **109** is formed on the glass substrate **101** at its lower surface. Thus, the TFT substrate **10** is completed.

In the TFT substrate **10**, the island **106** of the thin film transistor **114** is formed, in an area at which the scanning line **102** and the signal line **103** intersect with each other, such that the island **106** is almost within a width of the scanning line **102**. Accordingly, it is no longer necessary to arrange

the thin film transistor **114** in the pixel area **104** surrounded by the scanning line **102** and the signal line **103**. In the pixel area **104** is formed on the contact hole **106** through which the source electrode **112** is electrically connected to the transparent electrode **117**. Hence, an area of the pixel area **104**, namely, an area of the transparent electrode **117** is not reduced by the thin film transistor **114** in the liquid crystal display device **10** in accordance with the first embodiment, ensuring enhancement of an aperture ratio.

FIG. 7 is a graph showing a relation between an aperture ratio and a length of a side of the pixel area **104** (pixel size) which is varied in the range of 100 to 400 micrometers. It is assumed in FIG. 7 that a size of the thin film transistor **114**, a width of each of the lines, and a size of the contact hole **116** remain unchanged, even if a pixel size varies.

As is obvious in view of FIG. 7, it is understood that even if a pixel size is small, it would be possible to suppress reduction in an aperture ratio, and that the present invention suppresses reduction in an aperture ratio to a greater degree in a smaller pixel size in comparison with a conventional liquid crystal display device.

In accordance with the above-mentioned method of fabricating the liquid crystal display device **10** in accordance with the first embodiment, it would be possible to concurrently form the signal line **103** and the source electrode **102** in a common photolithography to be carried out for etching a common metal film, specifically, the fourth photolithography in the first embodiment. Accordingly, comparing to the above-mentioned conventional method in which source/drain electrodes and a signal line are formed in separate photolithography steps, the present invention makes it possible to reduce the number of photolithography steps by once, ensuring simplification in fabrication of a liquid crystal display device.

[Second Embodiment]

FIG. 8 is a partially enlarged view of a TFT substrate in a liquid crystal display device in accordance with the second embodiment. FIG. 8 corresponds to FIG. 4, and parts or elements that correspond to those of the TFT substrate **10** illustrated in FIG. 4 have been provided with the same reference numerals, and operate in the same manner as corresponding parts or elements in the first embodiment, unless explicitly explained hereinbelow.

In the above-mentioned first embodiment, the source electrode **112** is designed to have the rectangular area **120** at which the source electrode **112** is connected to the light-shielding layer **115**. The rectangular area **120** is designed to have an increased width or an enlarged area for forming the contact hole **116** therein. In contrast, the source electrode **120** in the second embodiment is designed not to have an enlarged area corresponding to the rectangular area **120**, but the contact hole **116** is designed to have a rectangular cross-section having a longer side extending in a length-wise direction of the light-shielding layer **115**.

In accordance with the second embodiment, since the source electrode **112** does not have a portion projecting into the pixel area **104**, it would be possible to avoid an area of the pixel area **104** from being reduced, and hence, enhance an aperture ratio.

[Third Embodiment]

FIG. 9 is a partially enlarged view of a TFT substrate in a liquid crystal display device in accordance with the third embodiment. FIG. 9 corresponds to FIG. 4, and parts or elements that correspond to those of the TFT substrate **10** illustrated in FIG. 4 have been provided with the same reference numerals, and operate in the same manner as corresponding parts or elements in the first embodiment, unless explicitly explained hereinbelow.

In the third embodiment, the signal line **103** is designed to have a portion having a reduced width, in an area at which the scanning line **102** and the signal line **103** intersect with each other. The portion having a reduced width is designed to extend across the island **106** for acting as the drain electrode **111**.

In accordance with the third embodiment, it would be possible to design the signal line **103** to have an increased width in almost all portions thereof in a length-wise direction, ensuring reduction in a resistance of the signal line **103**.

While the present invention has been described in connection with certain preferred embodiments, it is to be understood that the subject matter encompassed by way of the present invention is not to be limited to those specific embodiments. On the contrary, it is intended for the subject matter of the invention to include all alternatives, modifications and equivalents as can be included within the spirit and scope of the following claims.

The entire disclosure of Japanese Patent Application No. 2001-173578 filed on Jun. 8, 2001 including specification, claims, drawings and summary is incorporated herein by reference in its entirety.

What is claimed is:

1. An active matrix type liquid crystal display device comprising:

- (a) a transparent substrate;
- (b) a plurality of scanning lines formed on said transparent substrate;
- (c) a plurality of signal lines formed on said transparent substrate perpendicularly to the scanning lines;
- (d) a transparent electrode arranged in a pixel area defined by said scanning and signal lines; and
- (e) a thin film transistor formed in association with said transparent electrode,

wherein said thin film transistor is formed in an area at which one of said scanning lines and one of said signal lines intersect with each other,

wherein said thin film transistor includes source and drain regions both comprised of an electrically conductive film of which said signal lines are comprised, and

wherein each of said scanning lines has a portion having a decreased width in said area at which one of said scanning lines and one of said signal lines intersect with each other, said portion acting as a gate electrode of said thin film transistor.

2. The active matrix type liquid crystal display device as set forth in claim 1, wherein said thin film transistor is comprised of:

- (e1) an island including a gate insulating film and a semiconductor layer both formed on each of said scanning lines in said area at which one of said scanning lines and one of said signal lines intersect with each other;
- (e2) a drain electrode comprised of a part of each of said signal lines which part extends across said island; and
- (e3) a source electrode comprised of an electrically conductive film of which each of said signal lines is comprised, and formed on said island with being spaced away from said drain electrode.

3. The active matrix type liquid crystal display device as set forth in claim 1, further comprising a light-shielding layer surrounding said transparent electrode and being connected to said source electrode, said light-shielding layer being formed with a contact hole through which said source electrode is electrically connected to said transparent electrode.

## 11

4. The active matrix type liquid crystal display device as set forth in claim 3, wherein said light-shielding layer has a portion having an increased width, said contact hole being formed at said portion.

5. The active matrix type liquid crystal display device as set forth in claim 3, wherein said light-shielding layer has a uniform width.

6. The active matrix type liquid crystal display device as set forth in claim 5, wherein said contact hole is located within said light-shielding layer of uniform width.

7. The active matrix type liquid crystal display device as set forth in claim 6, wherein said contact hole has a rectangular cross-section having a longer side extending in a length-wise direction of said light shielding layer.

8. The active matrix type liquid crystal display device as set forth in claim 1, further comprising an island formed on each of said scanning lines at said portion having a decreased width, said island including a gate insulating film and a semiconductor layer both of which is greater in width than said portion.

9. The active matrix type liquid crystal display device as set forth in claim 8, further comprising a first ohmic layer and a second ohmic layer both formed on said semiconductor layer such that said first and second ohmic layers are spaced away from each other, said first ohmic layer being formed as an extension of each of said signal lines and acting as a drain electrode of said thin film transistor, said second ohmic layer acting as a source electrode of said thin film transistor.

10. The active matrix type liquid crystal display device as set forth in claim 1, wherein each of said signal lines has a portion having a decreased width in said area at which one of said scanning lines and one of said signal lines intersect with each other, said portion acting as a drain electrode of said thin film transistor.

11. A method of fabricating an active matrix type liquid crystal display device, comprising the steps of:

- (a) forming a plurality of scanning lines on a transparent substrate;
- (b) forming an island in an area at which one of said scanning lines and one of later mentioned signal lines intersect with each other, said island including a gate insulating film, a semiconductor layer and an ohmic layer all formed on each of said scanning lines in this order;
- (c) forming a plurality of signal lines extending perpendicularly to said scanning lines, each of said signal lines including a portion located on said island and acting as a drain electrode;
- (d) forming a source electrode on said island such that said source electrode faces and is spaced away from said drain electrode;
- (e) forming an interlayer insulating film entirely over a resultant resulted from said step (d);

## 12

(f) forming a contact hole so that said source electrode partially appears;

(g) forming a transparent electrode in a pixel area defined by said scanning and signal lines; and

(h) electrically connecting said transparent electrode to said source electrode through said contact hole,

wherein each of said scanning lines is formed to have a portion having a decreased width in said area at which one of said scanning lines and one of said signal lines intersect with each other, said portion acting as a gate electrode.

12. The method as set forth in claim 11, wherein said steps (c) and (d) are concurrently carried out.

13. The method as set forth in claim 11, wherein each of said signal lines and said source electrode are concurrently formed in a common photolithography step.

14. The method as set forth in claim 11, further comprising the step at forming a light-shielding layer which surrounds said transparent electrode and is connected to said source electrode, said light-shielding layer being formed with said contact hole.

15. The method as set forth in claim 14, wherein said light-shielding layer is formed to have a portion having an increased width, said contact hole being formed at said portion.

16. The method as set forth in claim 14, wherein said light-shielding layer is formed to have a uniform width, and said contact hole is located within said light-shielding layer of uniform width.

17. The method as set forth in claim 16, wherein said contact hole is formed to have a rectangular cross-section having a longer side extending in a length-wise direction of said light-shielding layer.

18. The method as set forth in claim 11, wherein said island is formed on each of said scanning lines at said portion having a decreased width, said gate insulating film and said semiconductor layer both being greater in width than said portion.

19. The method as set forth in claim 18, further comprising the step of forming a first ohmic layer and a second ohmic layer both on said semiconductor layer such that said first and second ohmic layers are spaced away from each other, said first ohmic layer being formed as an extension of each of said signal lines and acting as said drain electrode, said second ohmic layer acting as said source electrode.

20. The method as set forth in claim 11, wherein each of said signal lines is formed to have a portion having a decreased width in said area at which one of said scanning lines and one of said signal lines intersect with each other, said portion acting as said drain electrode.

\* \* \* \* \*

专利名称(译)	有源矩阵型液晶显示器件及其制造方法		
公开(公告)号	<a href="#">US6762805</a>	公开(公告)日	2004-07-13
申请号	US10/163612	申请日	2002-06-07
申请(专利权)人(译)	NEC公司		
当前申请(专利权)人(译)	NLT科技有限公司.		
[标]发明人	ISHINO TAKAYUKI		
发明人	ISHINO, TAKAYUKI		
IPC分类号	G02F1/13 G02F1/1368 G02F1/1362 G09F9/30 H01L29/786 G02F1/136 G02F1/1345		
CPC分类号	G02F1/1368 G02F1/136286 G02F2201/40		
代理机构(译)	FOLEY & Lardner的律师事务所		
审查员(译)	PARKER, KENNETH		
优先权	2001173578 2001-06-08 JP		
其他公开文献	US20020196382A1		
外部链接	<a href="#">Espacenet</a> <a href="#">USPTO</a>		

摘要(译)

一种有源矩阵型液晶显示装置，包括：(a)透明基板，(b)在透明基板上形成的多条扫描线，(c)在垂直于扫描线的透明基板上形成的多条信号线，(d)布置在由扫描线和信号线限定的像素区域中的透明电极，和(e)与透明电极相关联地形成的薄膜晶体管，薄膜晶体管形成在其中一条扫描线的区域中并且其中一条信号线彼此相交，薄膜晶体管包括源区和漏区，二者都包括构成信号线的导电膜。

