



US 20050280625A1

(19) **United States**

(12) **Patent Application Publication**
Yajima et al.

(10) **Pub. No.: US 2005/0280625 A1**

(43) **Pub. Date: Dec. 22, 2005**

(54) **LIQUID CRYSTAL DISPLAY DEVICE
HAVING AN IMPROVED BACKLIGHT**

(30) **Foreign Application Priority Data**

May 18, 2000 (JP) 2000-146500

(75) Inventors: **Toshihiro Yajima**, Mobara (JP); **Seiichi Nishiyama**, Mobara (JP); **Shigetake Takaku**, Mobara (JP); **Yoshiharu Takeda**, Mobara (JP); **Shigeo Mikoshiba**, Tokyo (JP); **Tomokazu Shiga**, Kawasaki (JP); **Koji Hashimoto**, Kawasaki (JP); **Yusuke Baba**, Fuchu (JP)

Publication Classification

(51) **Int. Cl.⁷** **G09G 3/36**
(52) **U.S. Cl.** **345/102**

Correspondence Address:

Stanley P. Fisher
Reed Smith Hazel & Thomas LLP
Suite 1400
3110 Fairview Park Drive
Falls Church, VA 22042-4503 (US)

(57) **ABSTRACT**

A liquid crystal display device includes a liquid crystal display panel having a liquid crystal layer sandwiched between a pair of transparent substrates, at least one of which has patterned electrodes on an inner surface thereof, and a backlight disposed behind the liquid crystal display panel. The backlight has at least one discharge tube including a sealed-off transparent tube, a phosphor film formed on an inner surface of the sealed-off transparent tube, and a discharge gas within the sealed-off transparent tube and plural electrodes spaced in a direction of an axis of the sealed-off transparent tube and positioned at least partially around a circumference of the sealed-off transparent tube. At least two adjacent ones of the plural electrodes is supplied with alternating voltages different in frequency from each other, respectively.

(73) Assignees: **Hitachi, Ltd.**; **Hitachi Electronic Devices, Ltd.**

(21) Appl. No.: **11/211,582**

(22) Filed: **Aug. 26, 2005**

Related U.S. Application Data

(63) Continuation of application No. 09/858,553, filed on May 17, 2001, now Pat. No. 6,956,556.

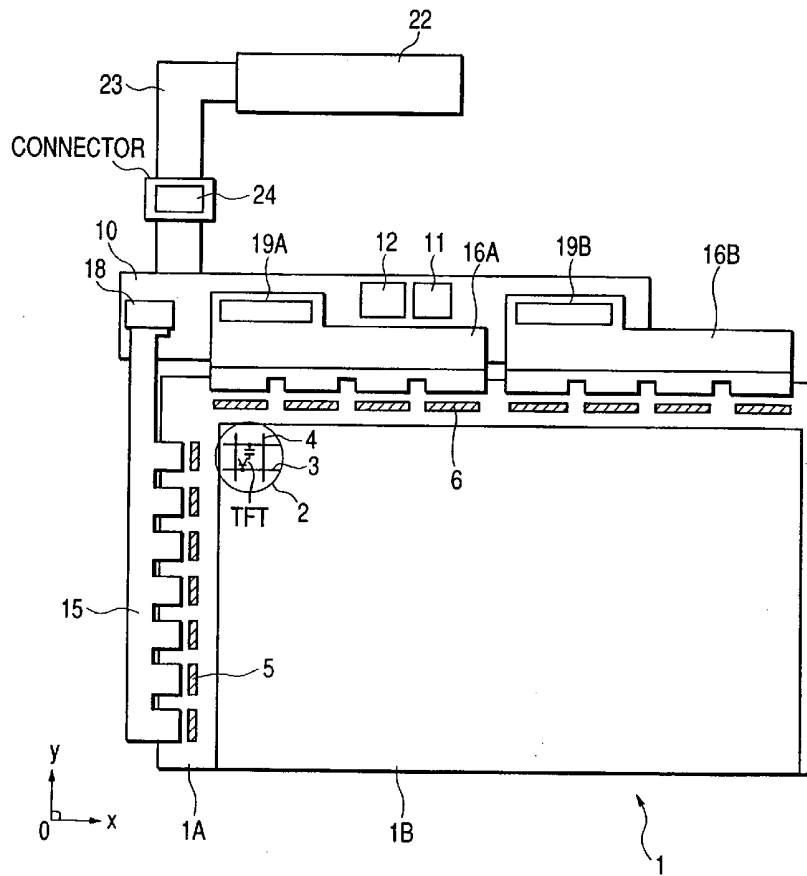

FIG. 1

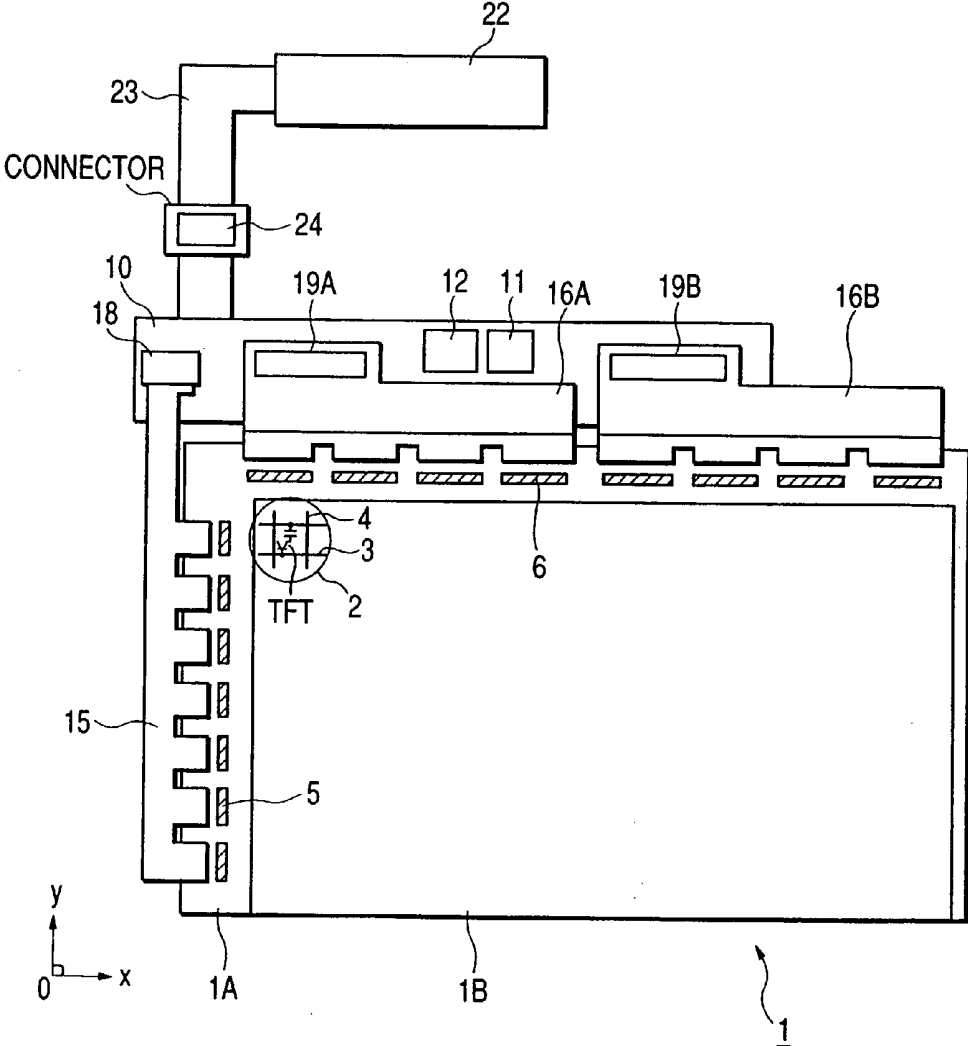

FIG. 2

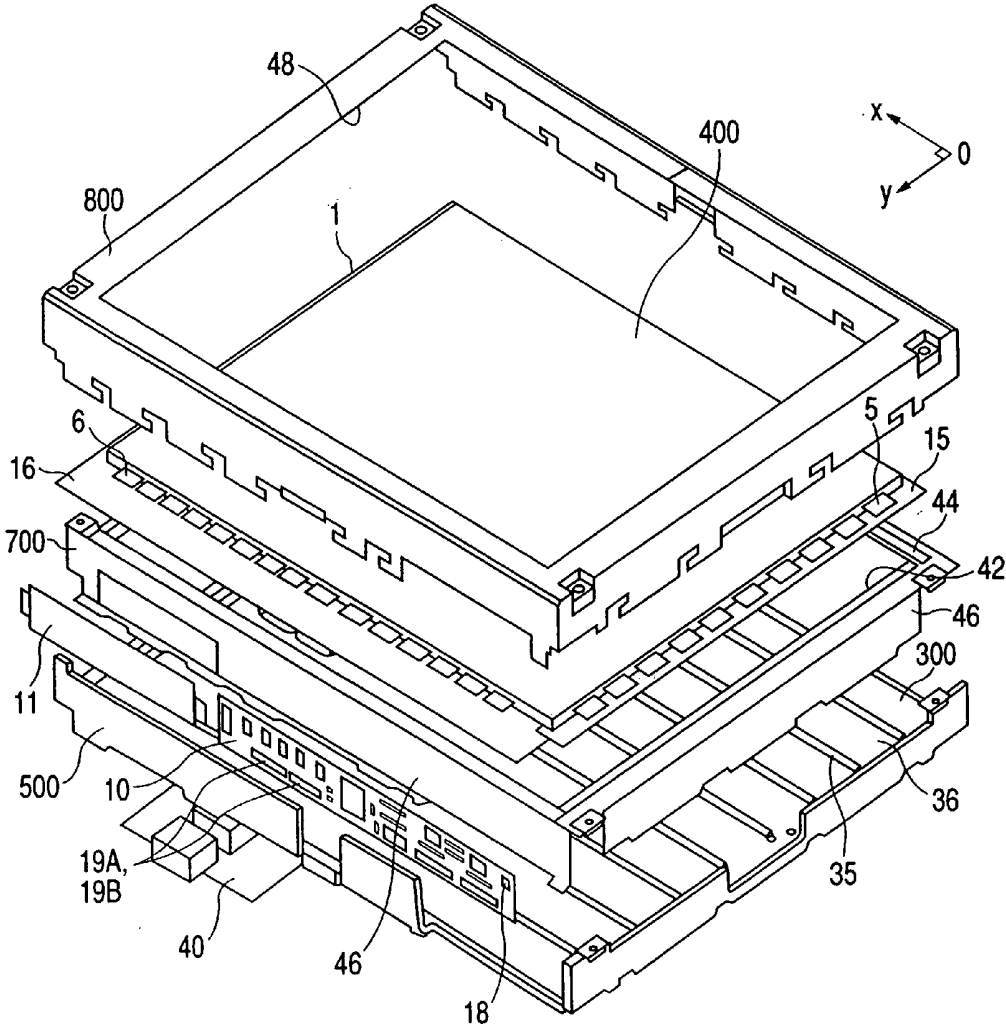

FIG. 3

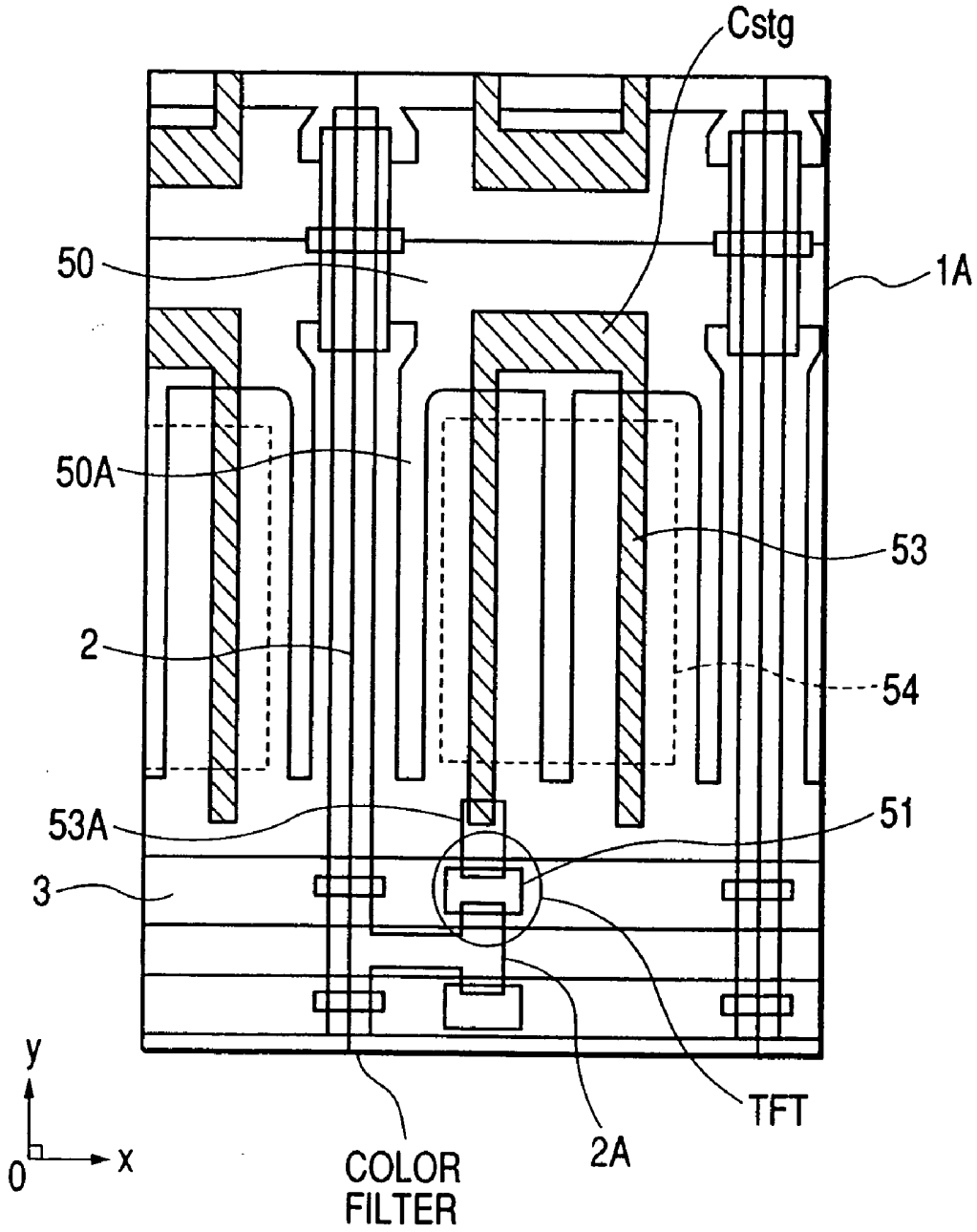

FIG. 4

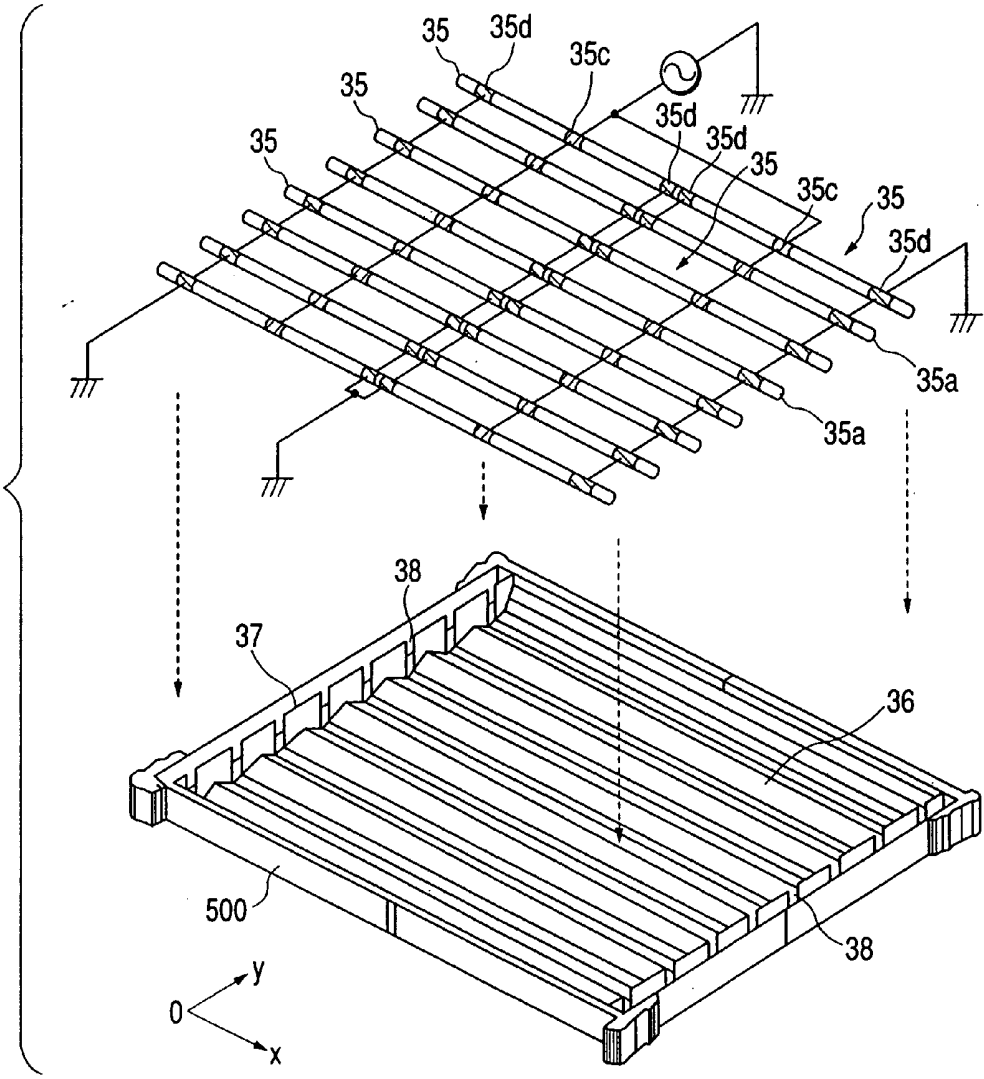

FIG. 5

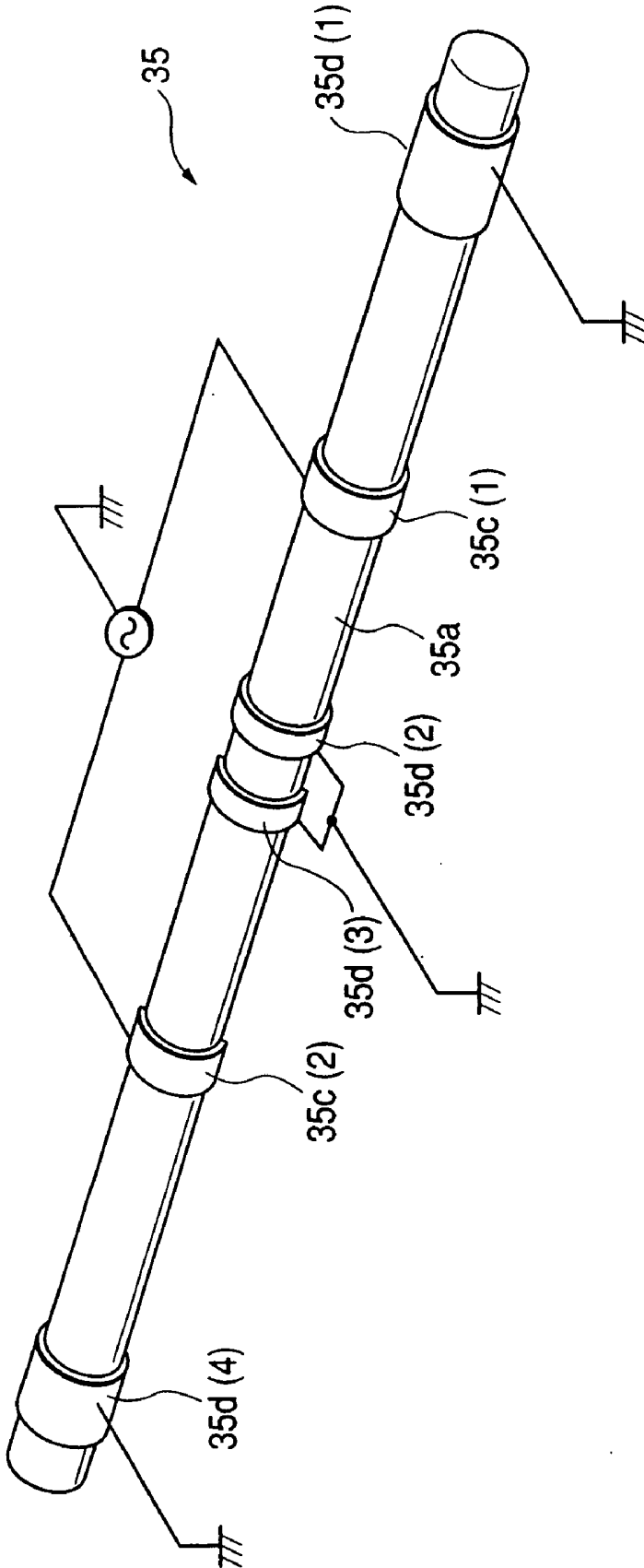

FIG. 6A

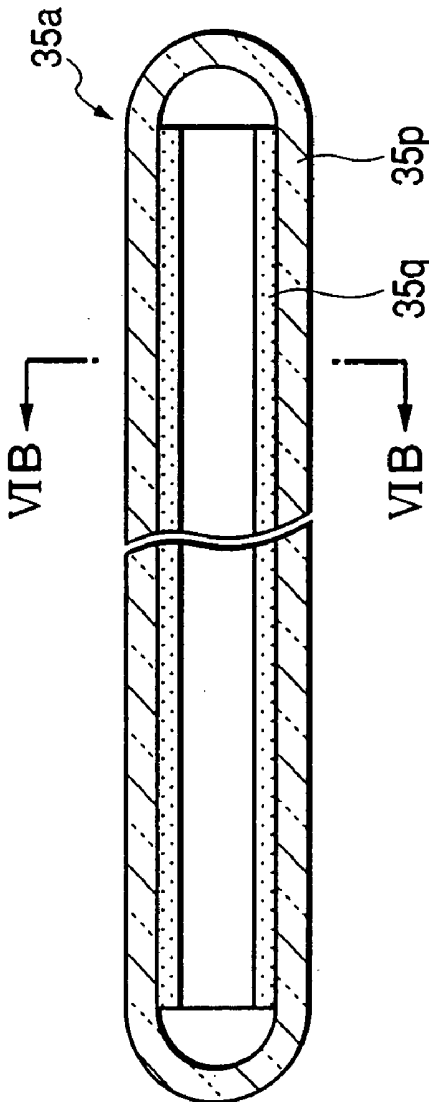

FIG. 6B

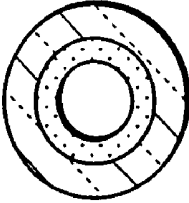

FIG. 7A

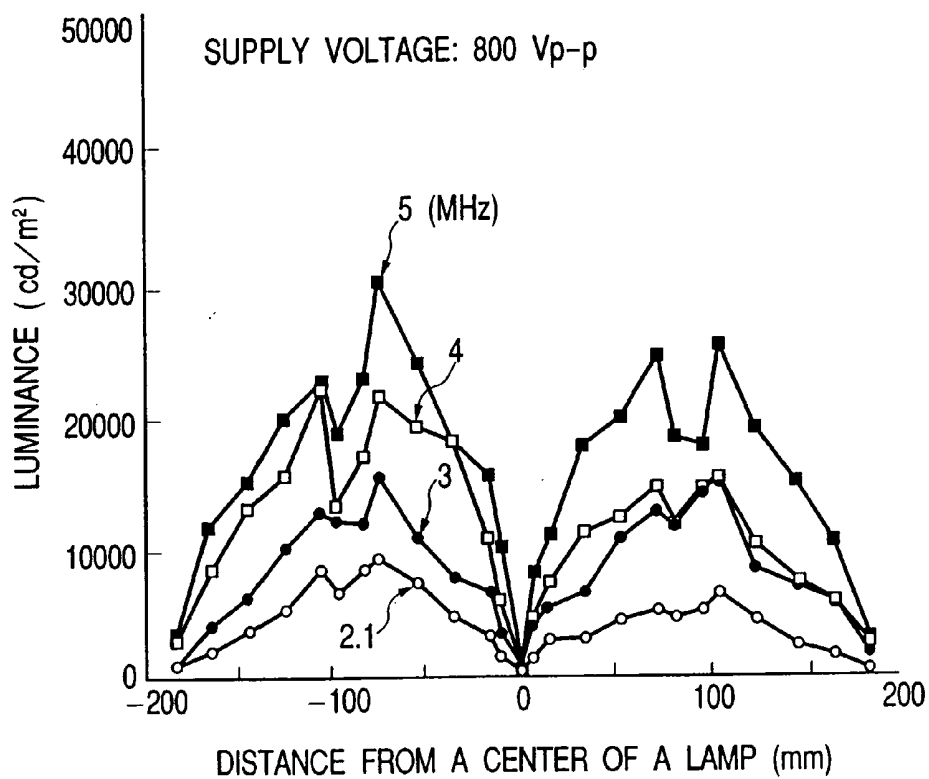

FIG. 7B

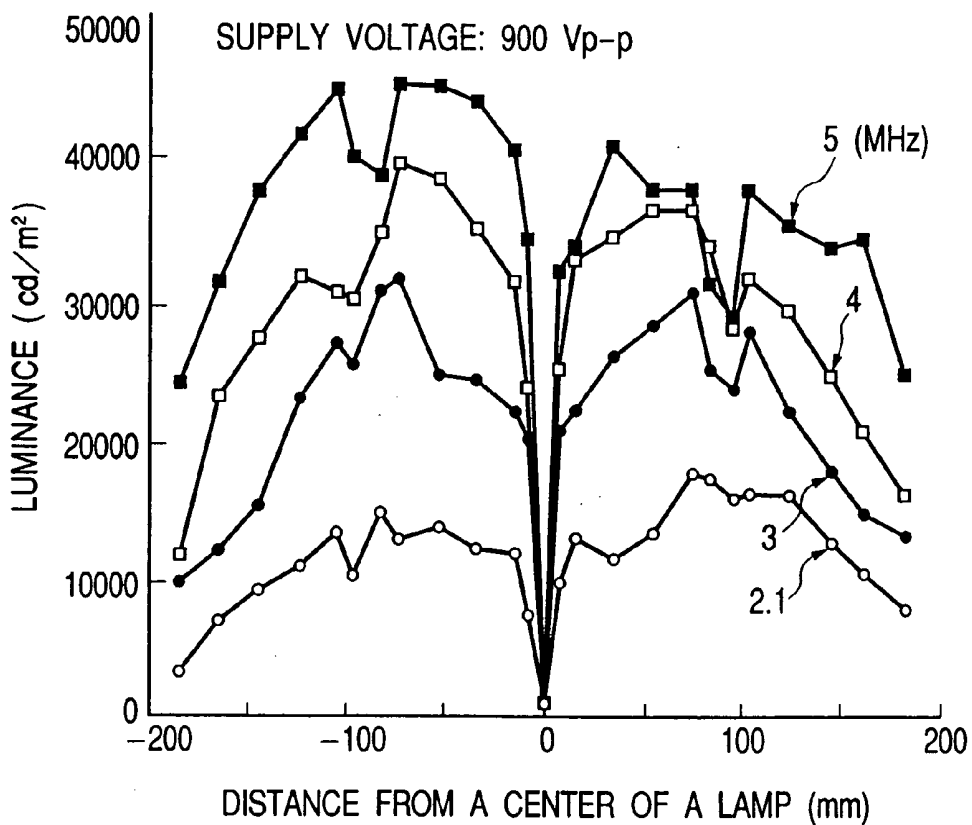

FIG. 7C

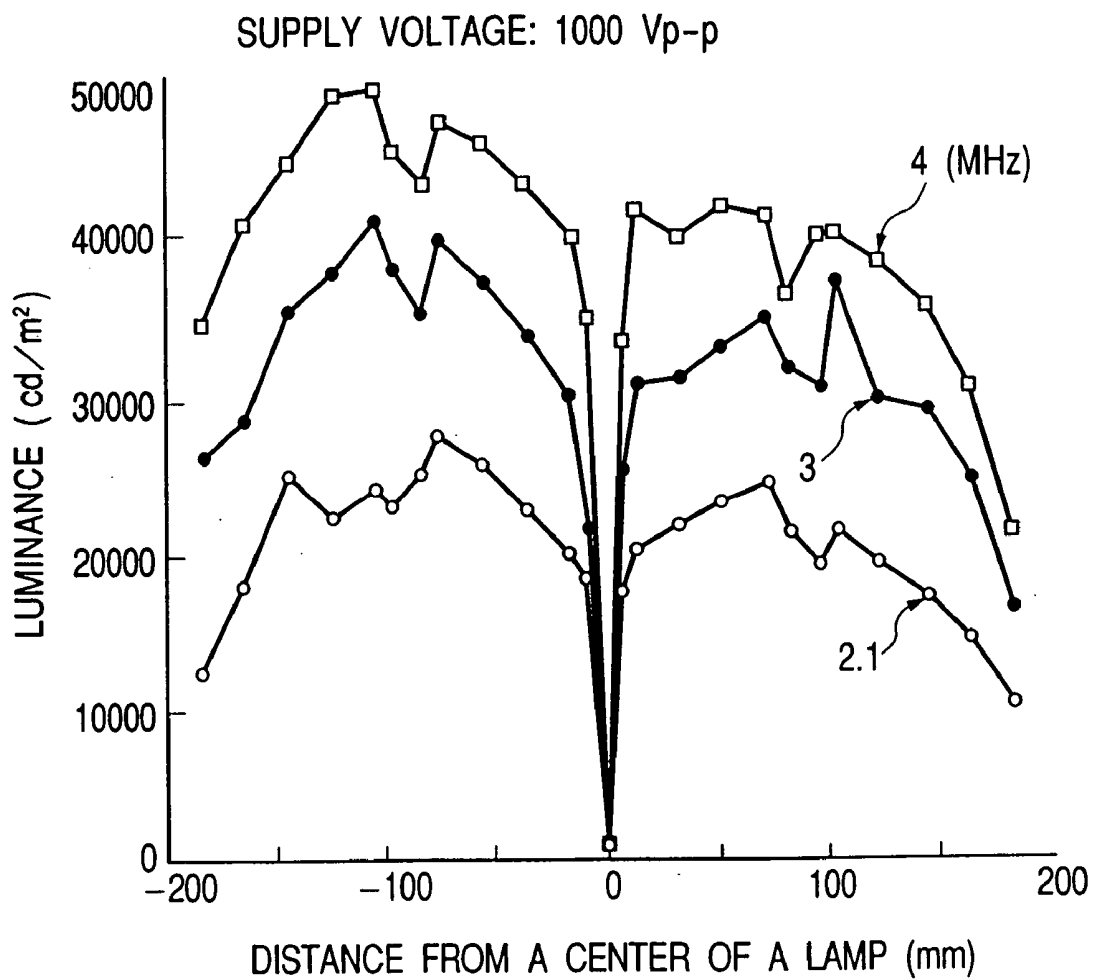

FIG. 8B

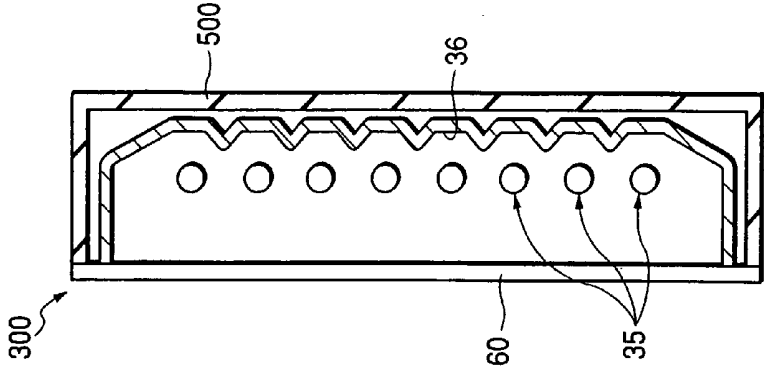

FIG. 8A

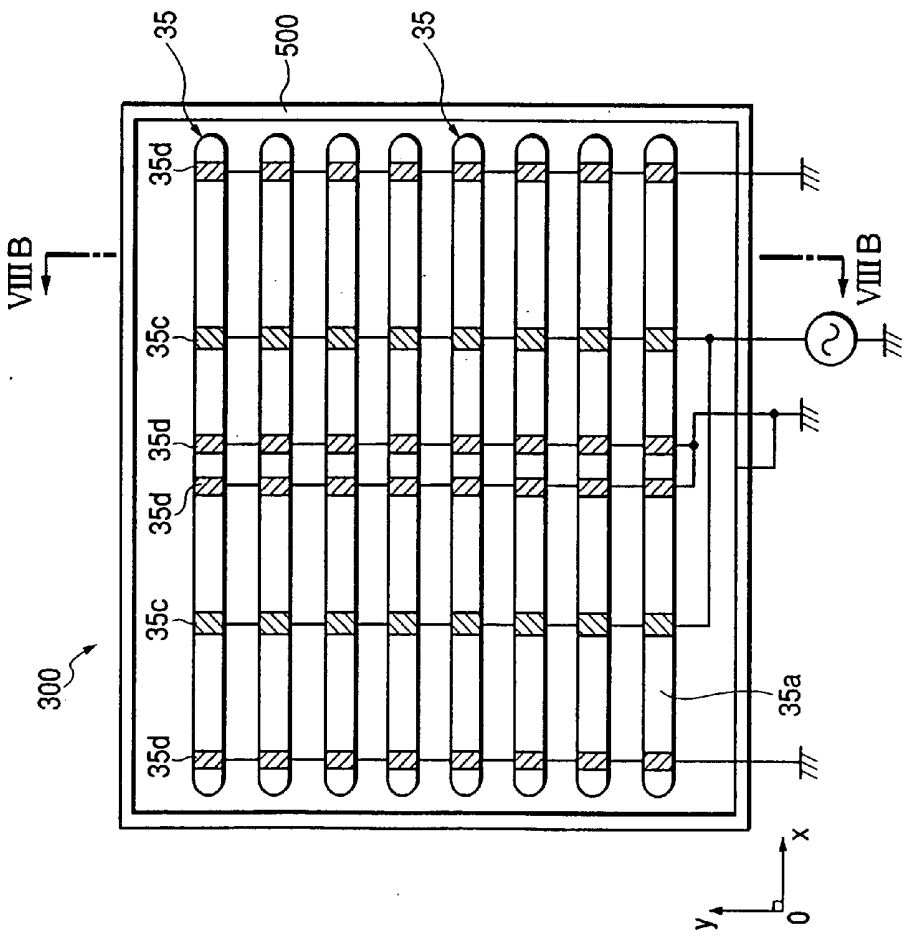

FIG. 9

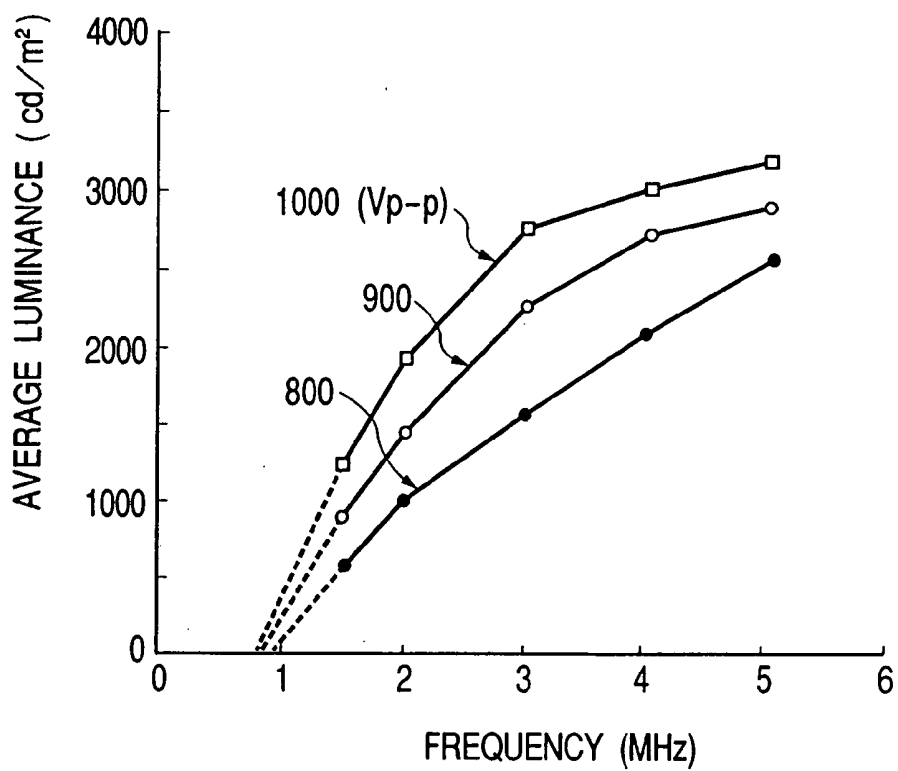

FIG. 10

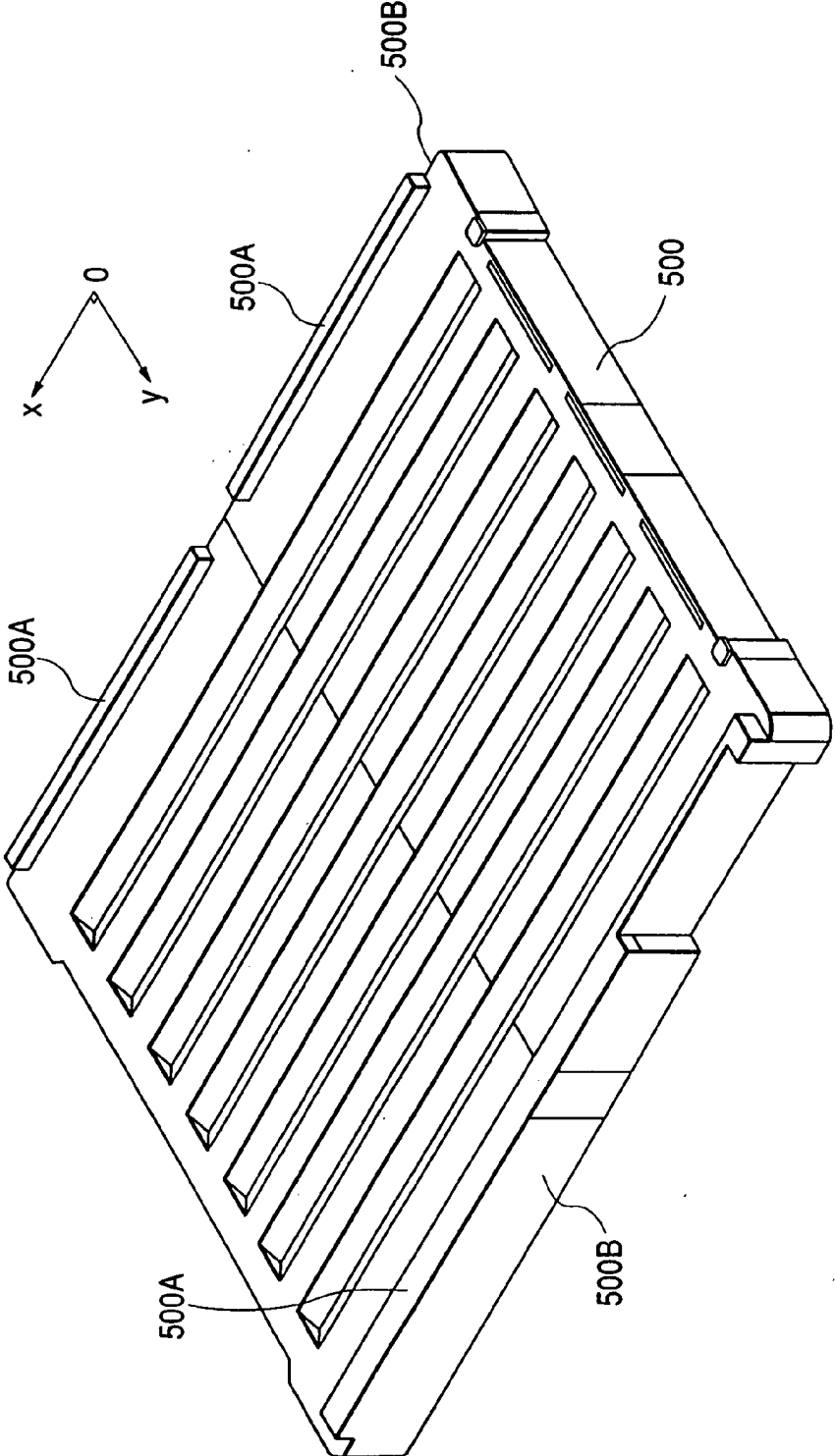

FIG. 11

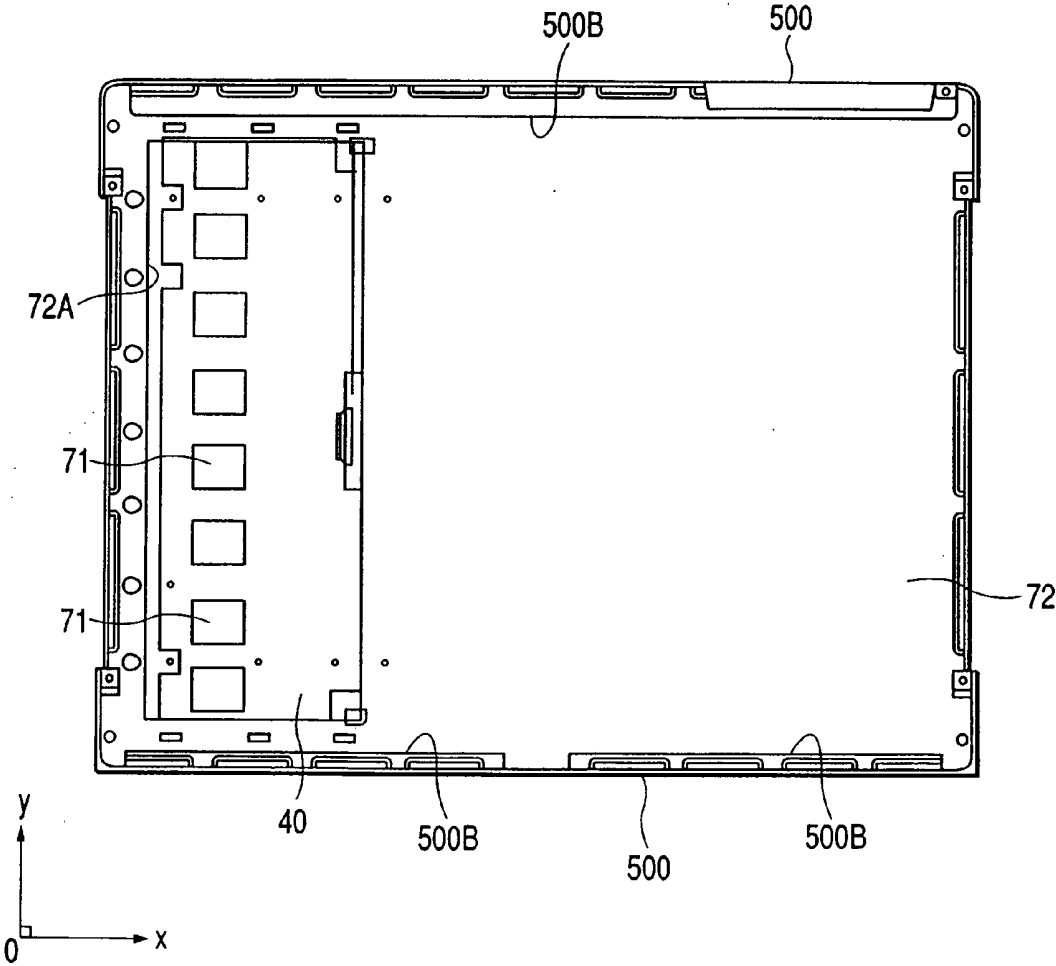

FIG. 12B

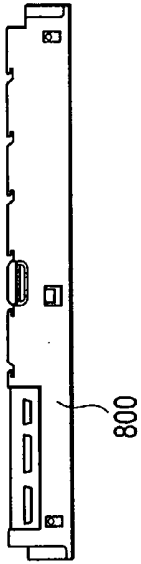

FIG. 12E

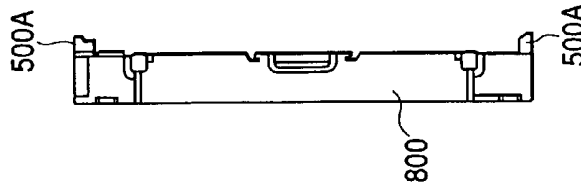

FIG. 12A



FIG. 12D

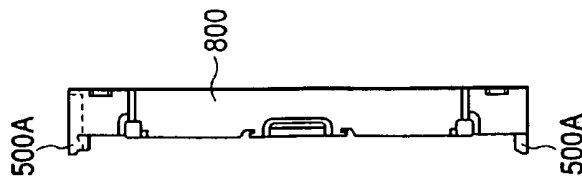

FIG. 12C

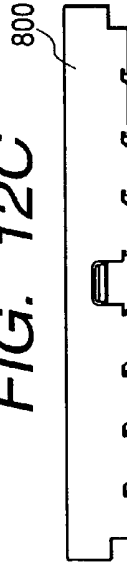

FIG. 13

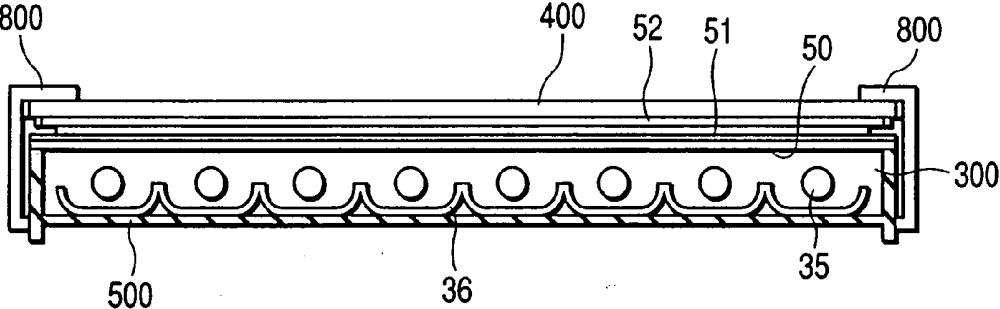

FIG. 14A

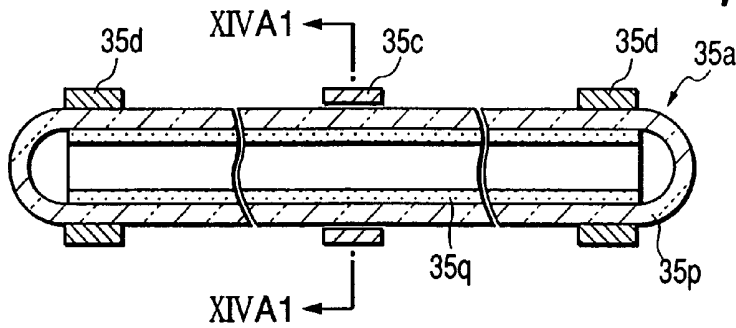

FIG. 14A1

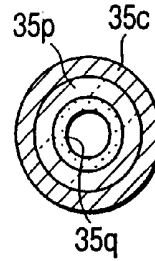

FIG. 14B

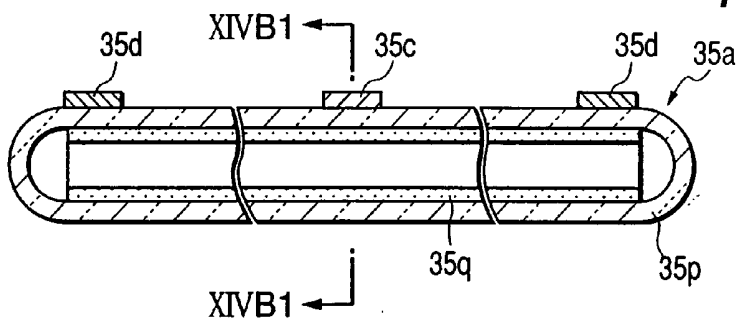

FIG. 14B1

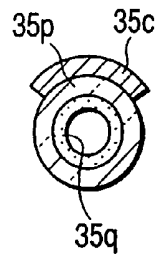

FIG. 14C

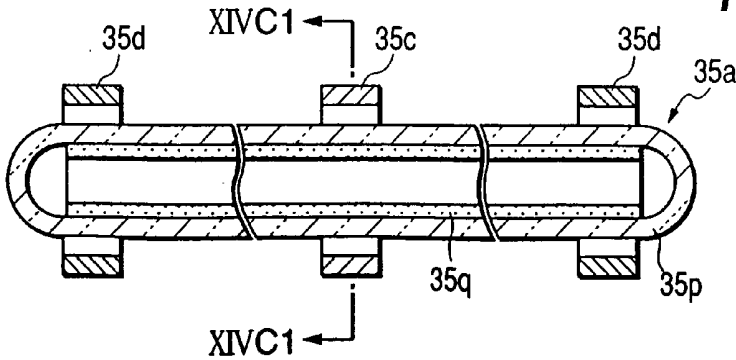
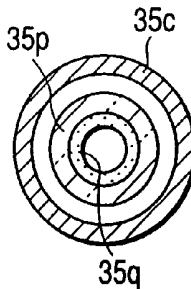

FIG. 14C1



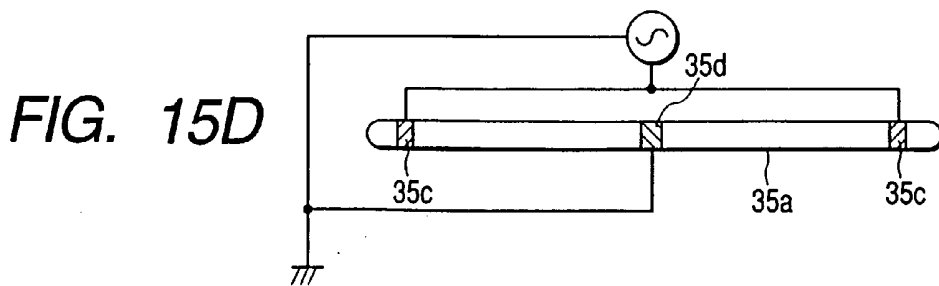
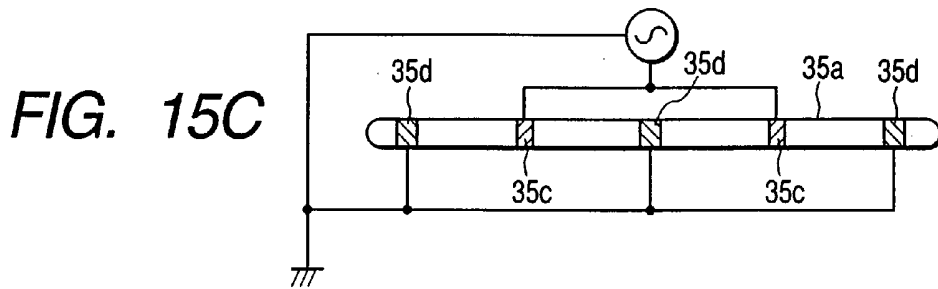
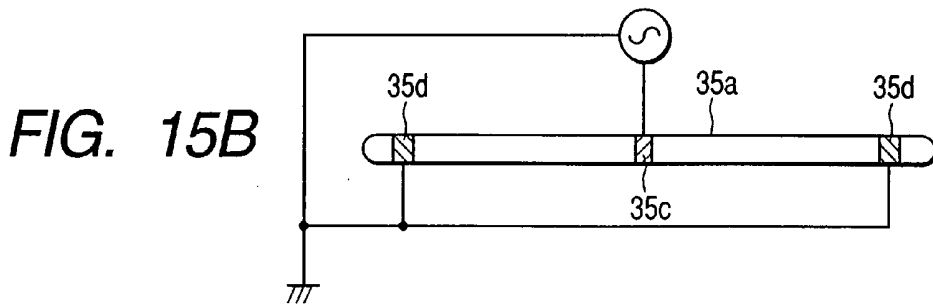
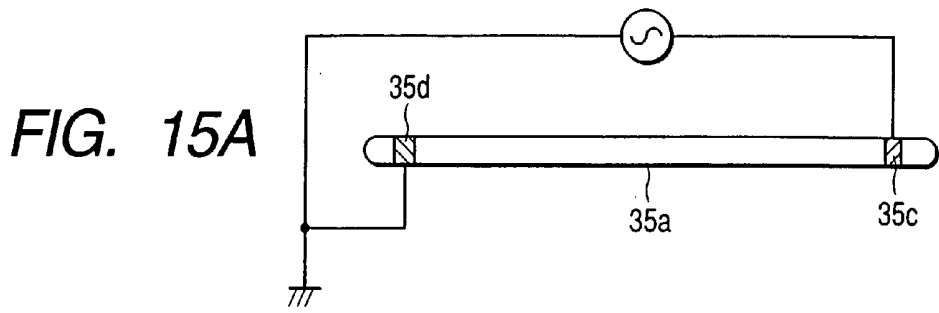

FIG. 16A

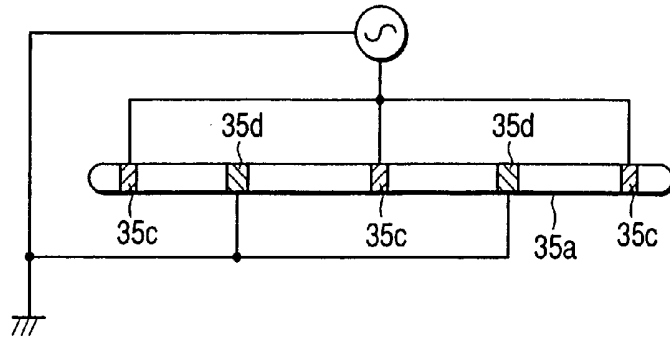

FIG. 16B

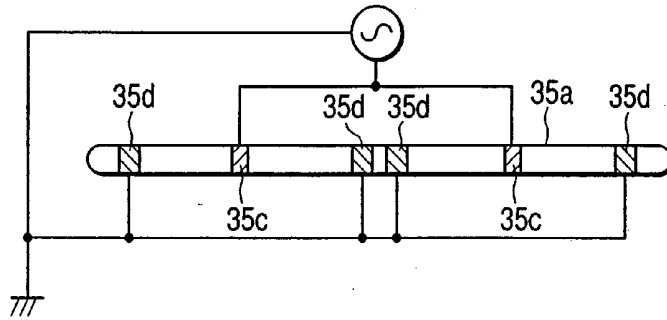

FIG. 16C

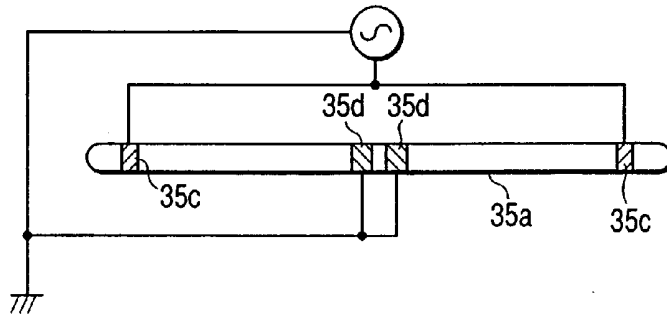

FIG. 16D

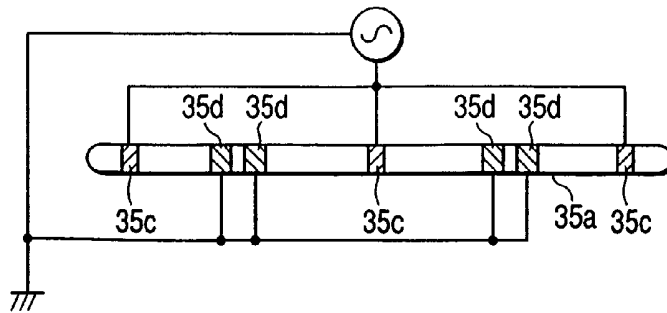

FIG. 17A

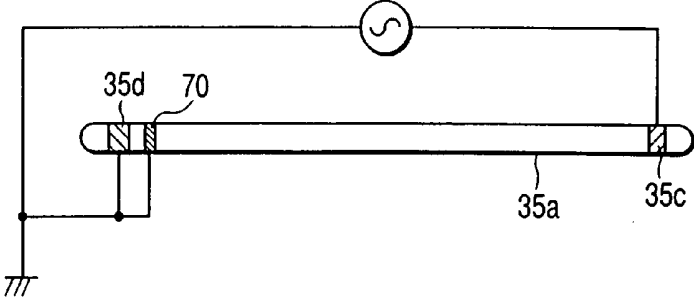

FIG. 17B

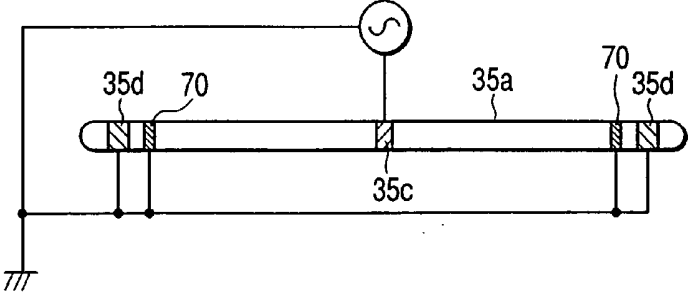

FIG. 17C

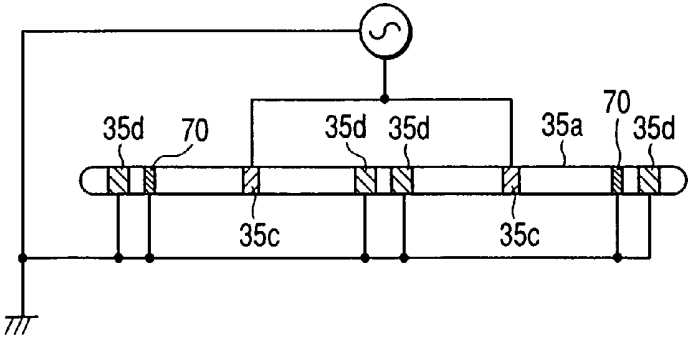

FIG. 18

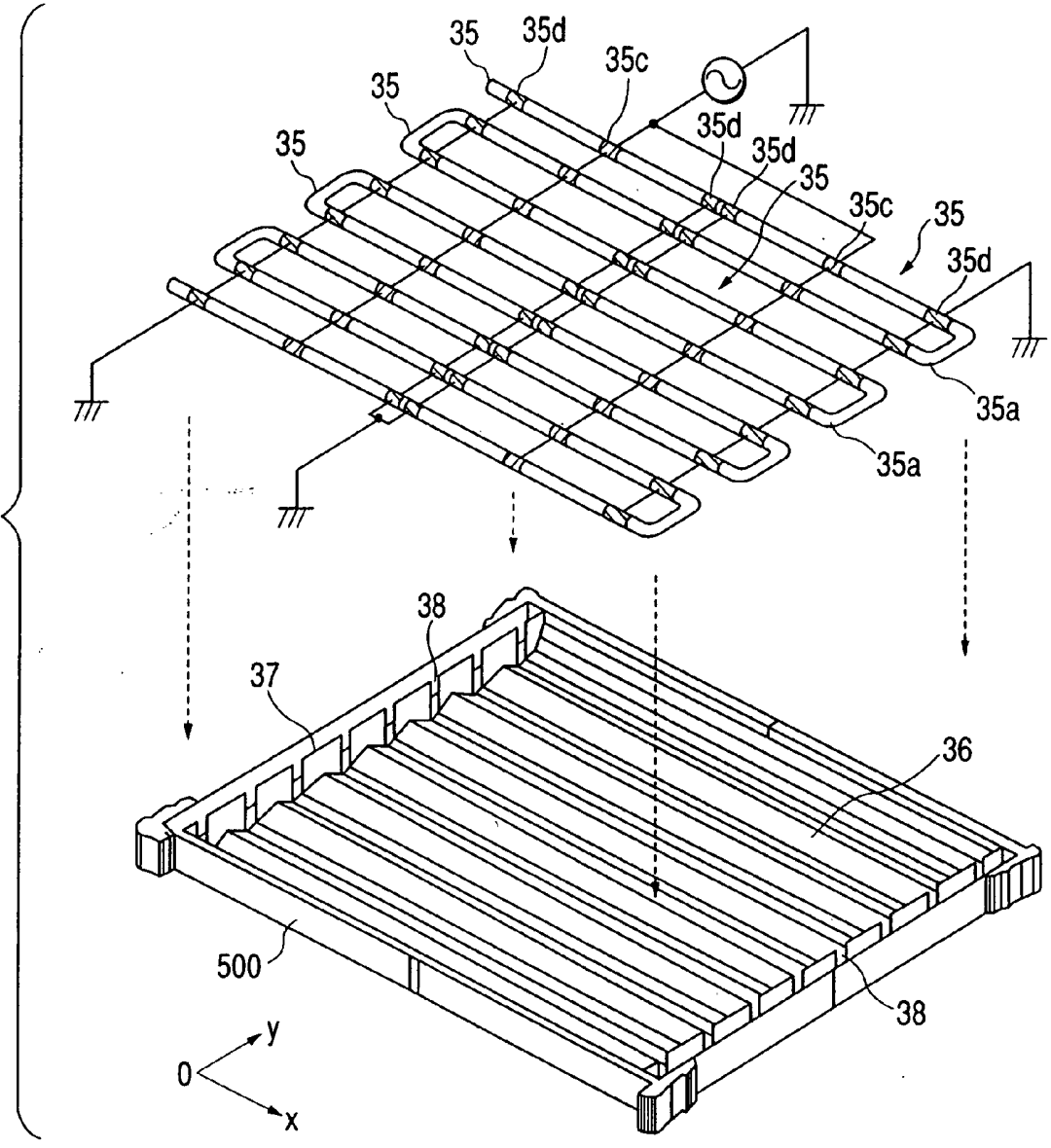

FIG. 19

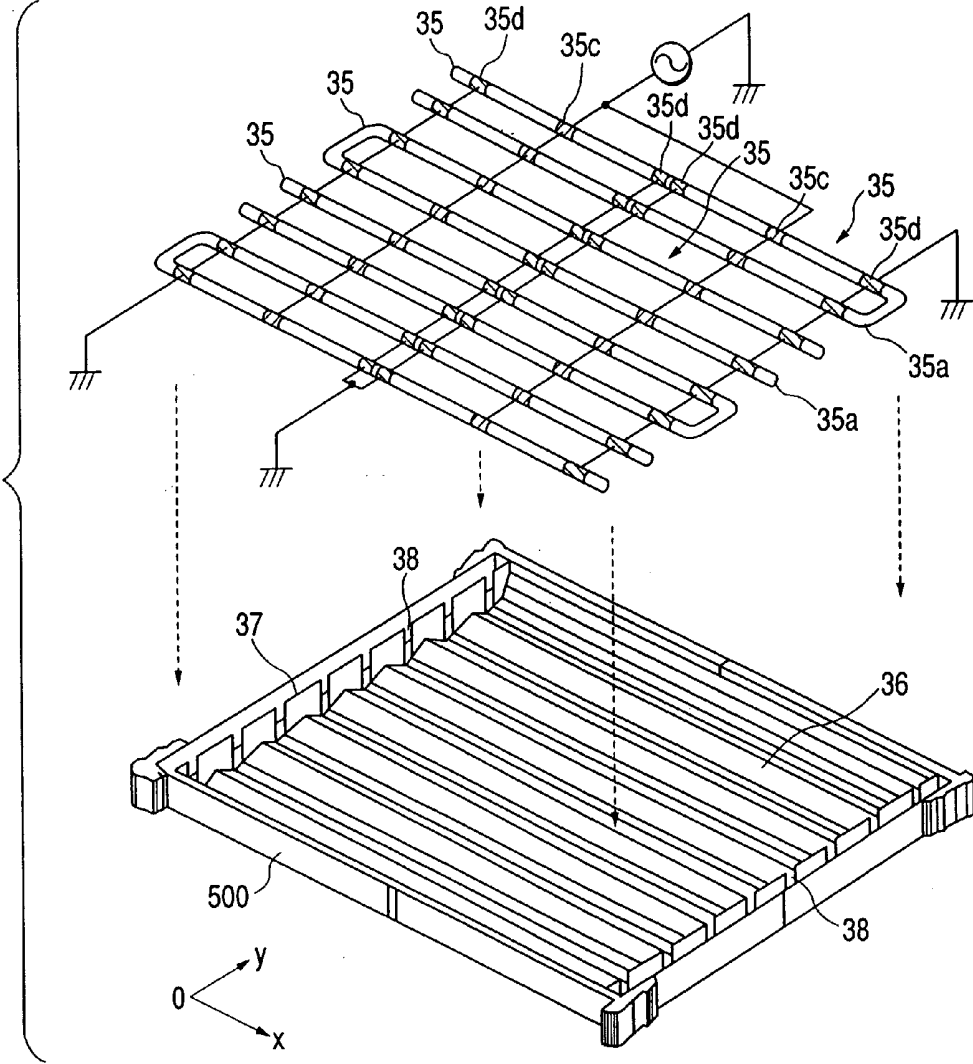

FIG. 20A

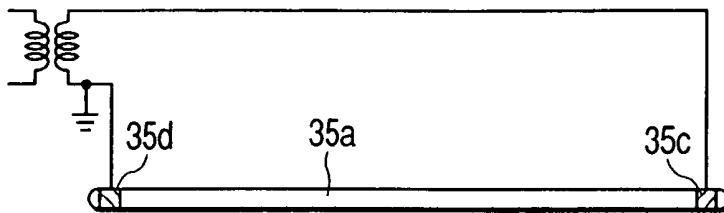

FIG. 20B

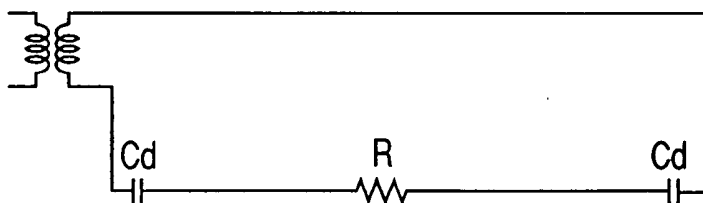

FIG. 21

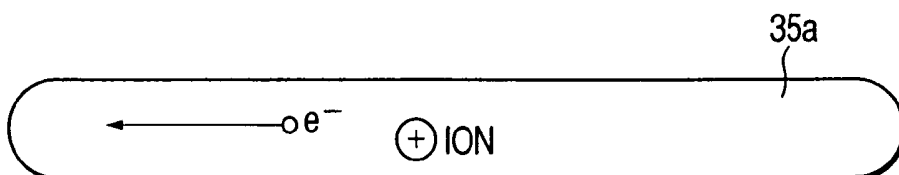

FIG. 22

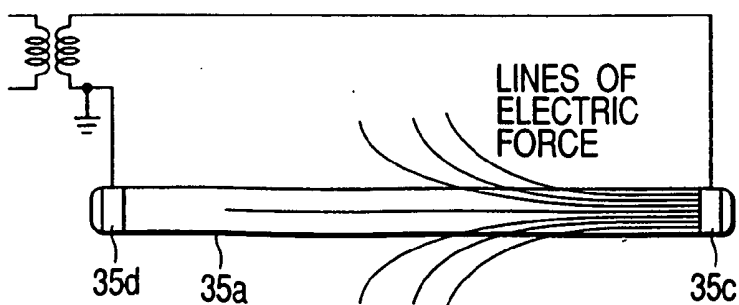

FIG. 23A

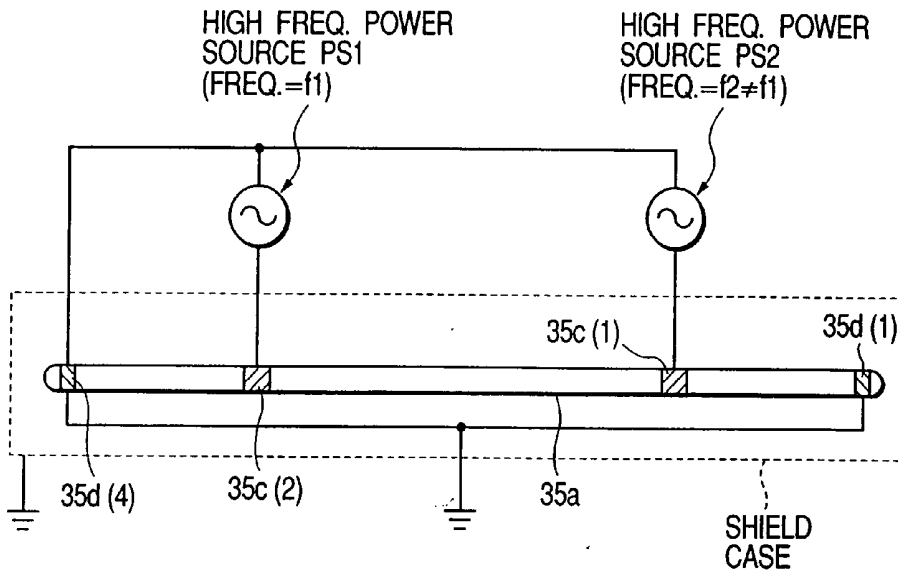

FIG. 23B

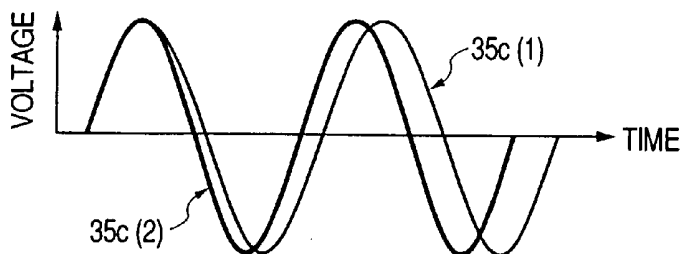

FIG. 24A

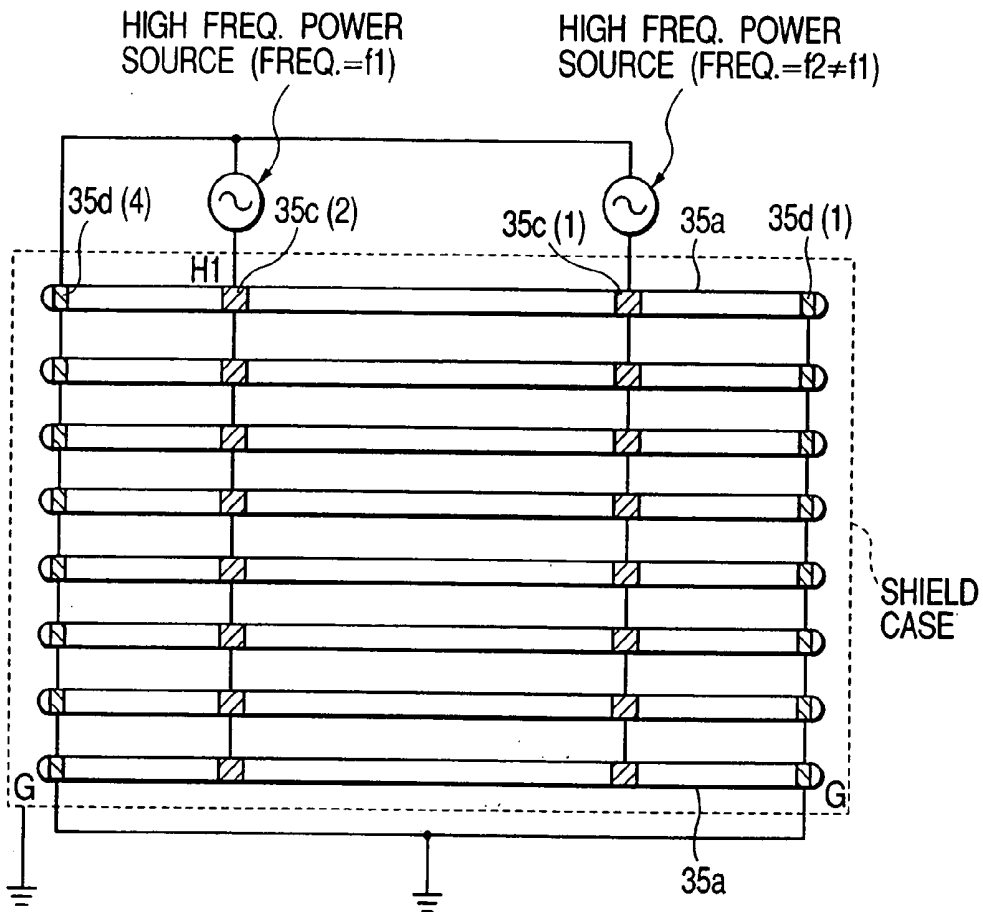

FIG. 24B

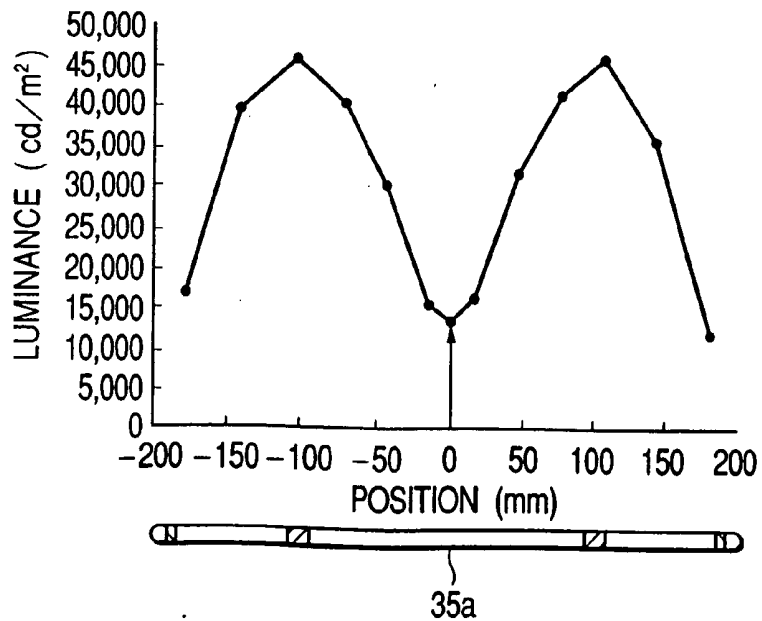

FIG. 25A

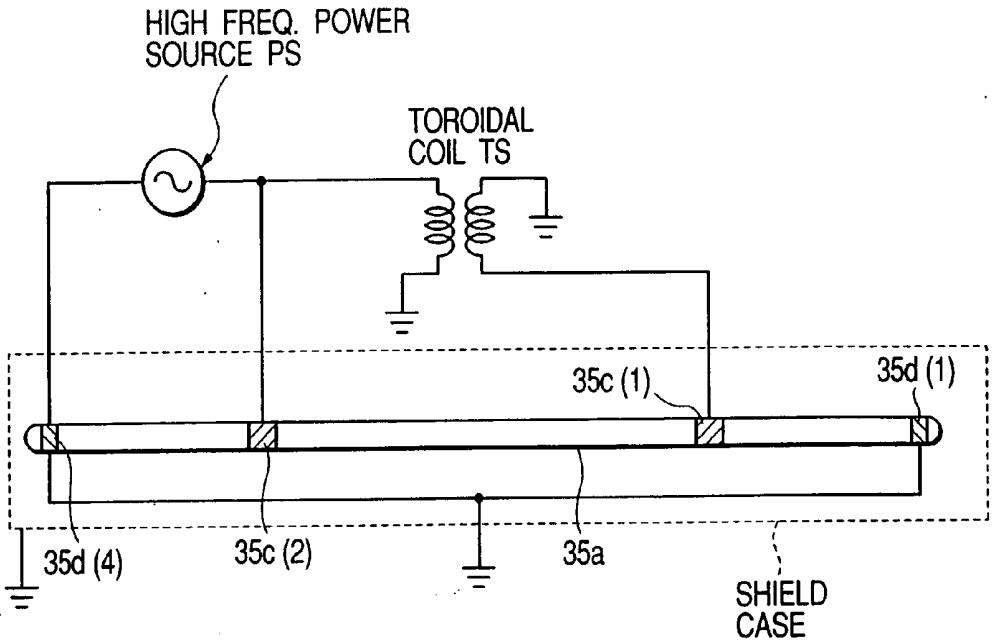

FIG. 25B

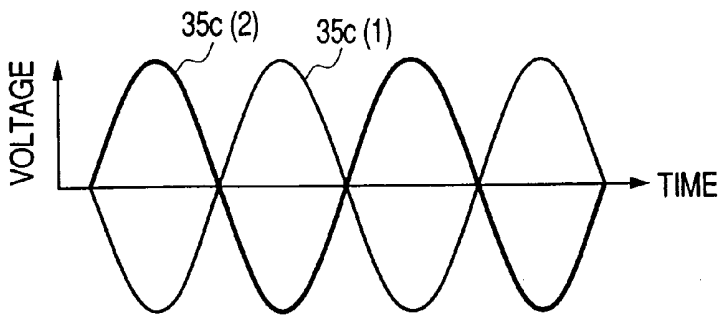

FIG. 26A

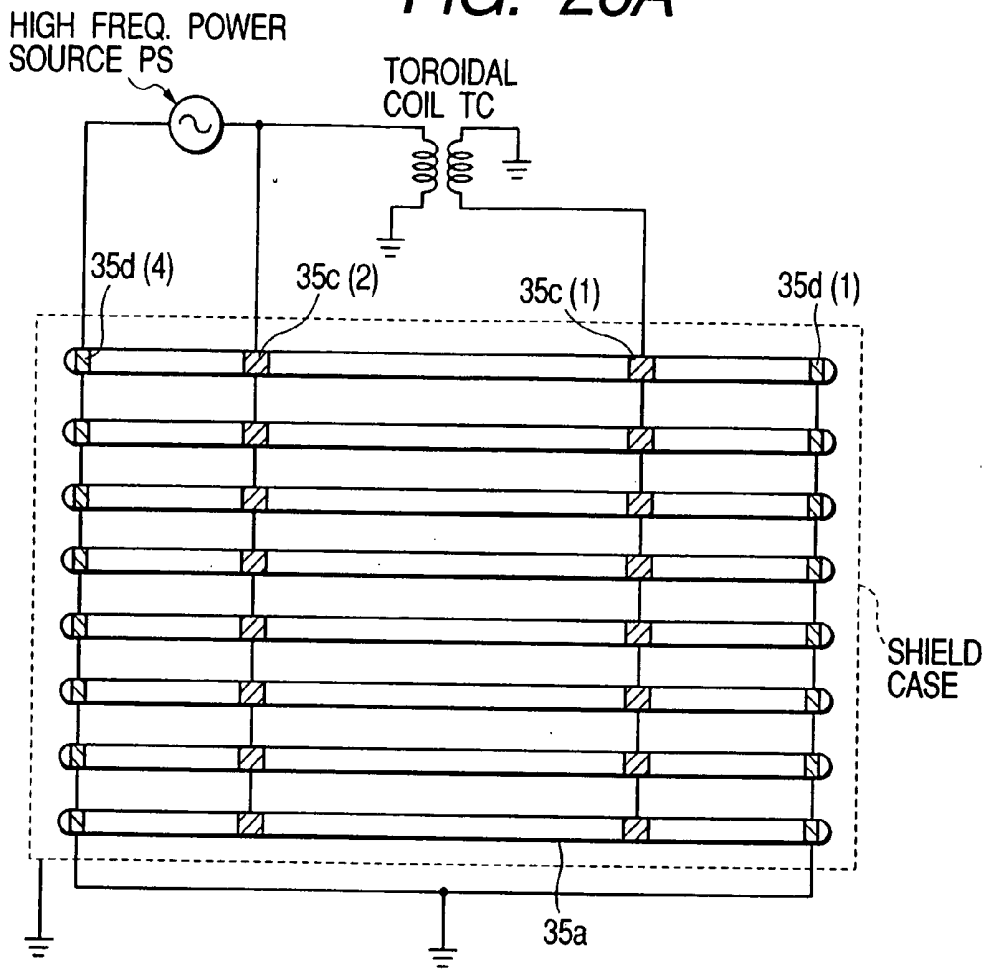

FIG. 26B

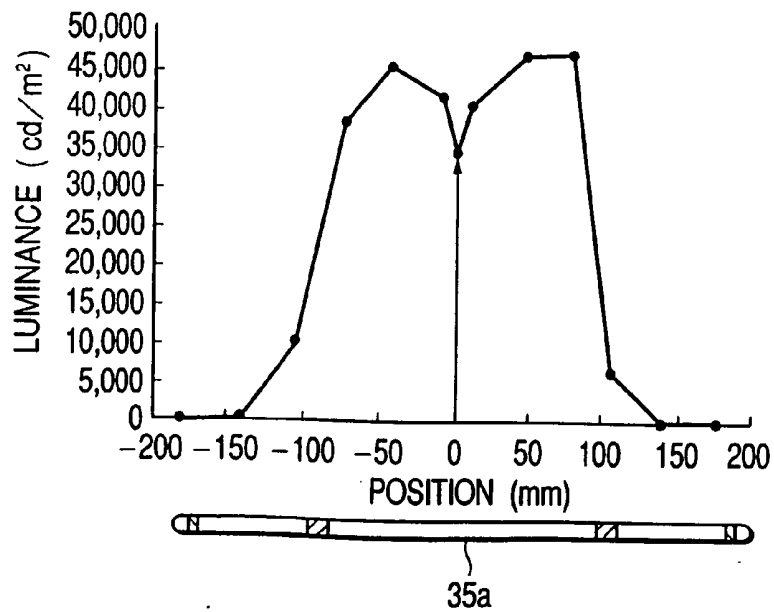

FIG. 27A

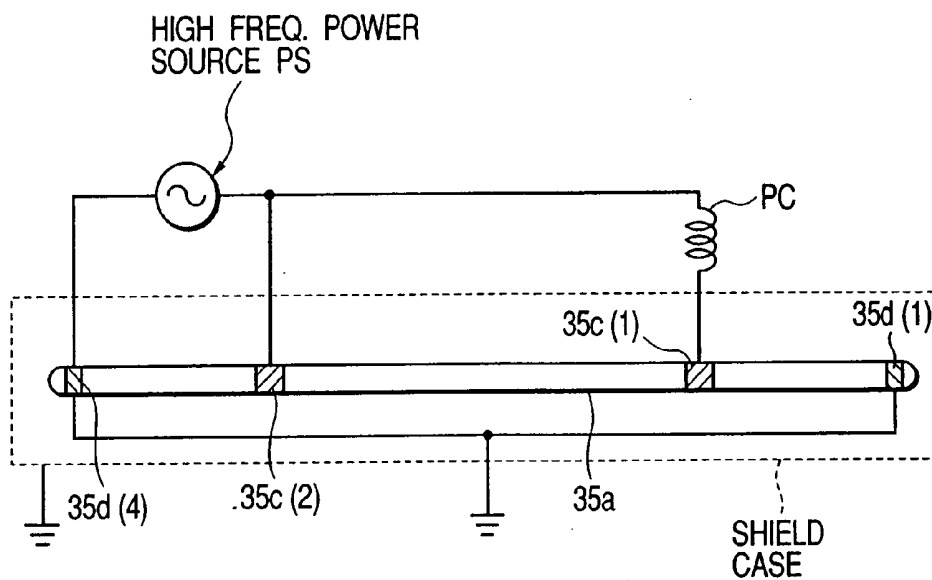

FIG. 27B

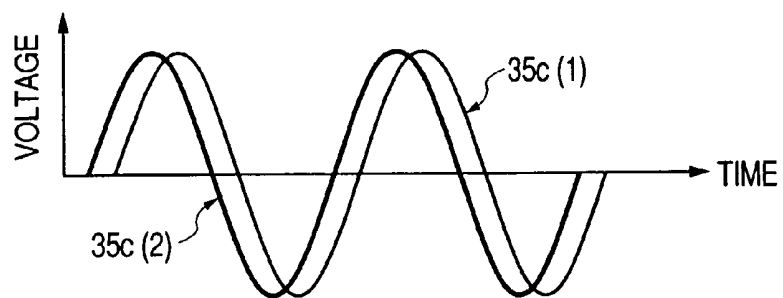

FIG. 28

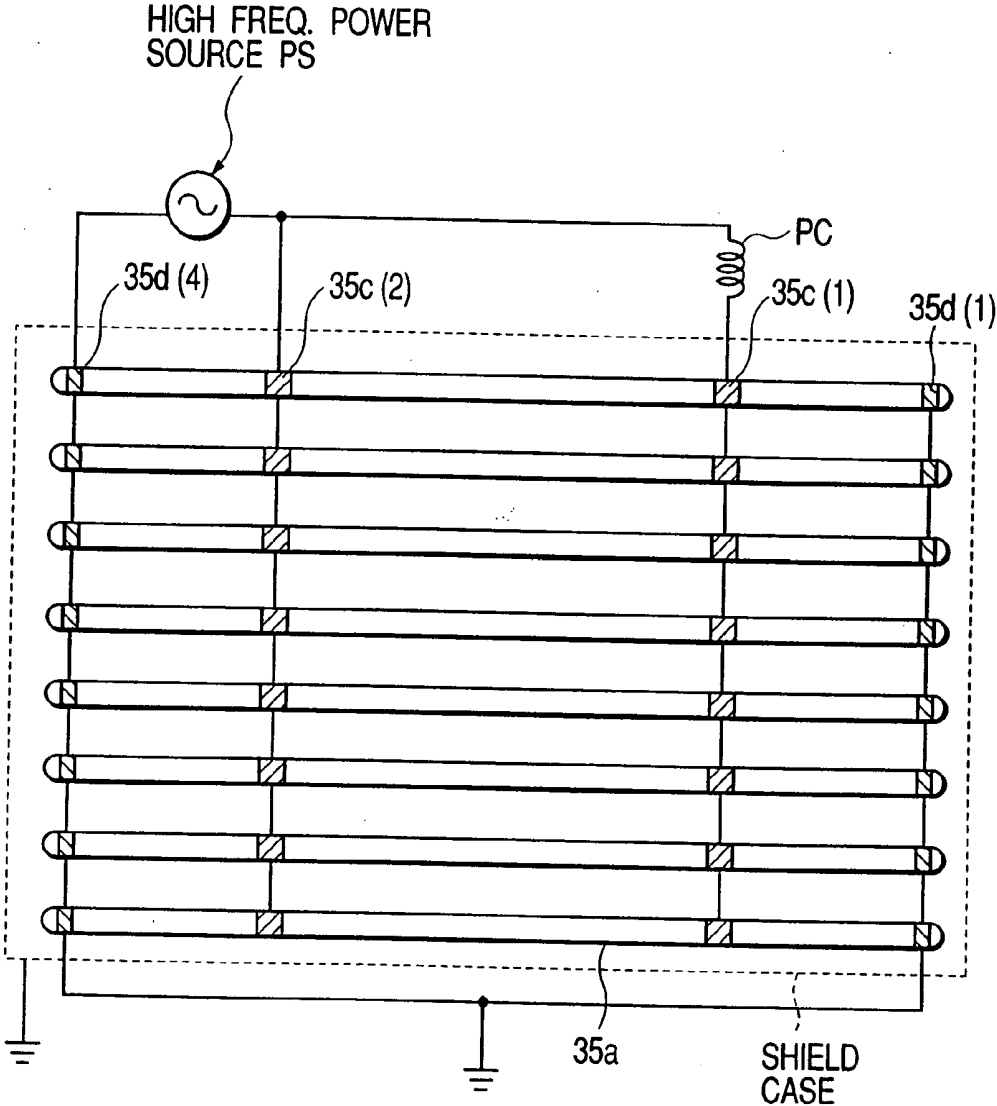

FIG. 29A

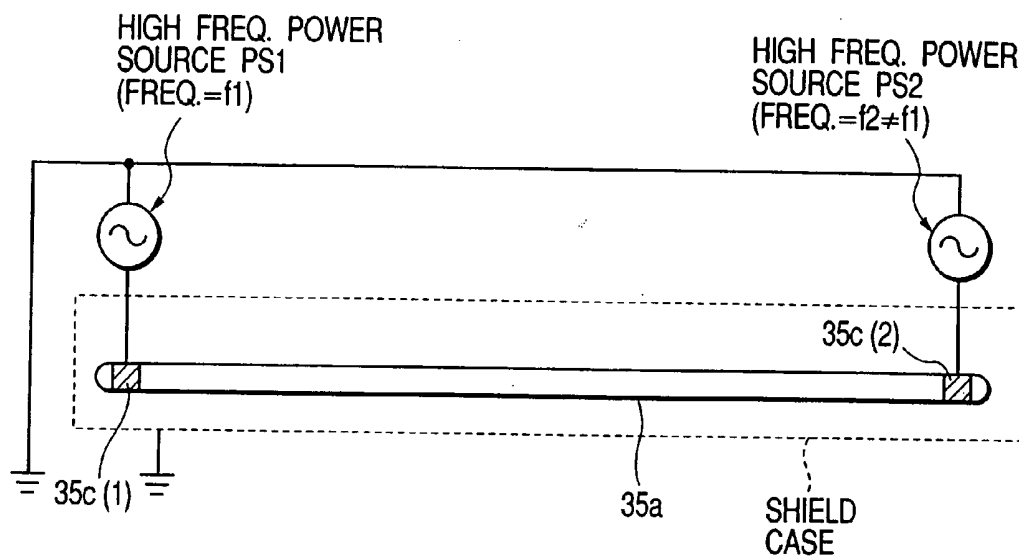

FIG. 29B

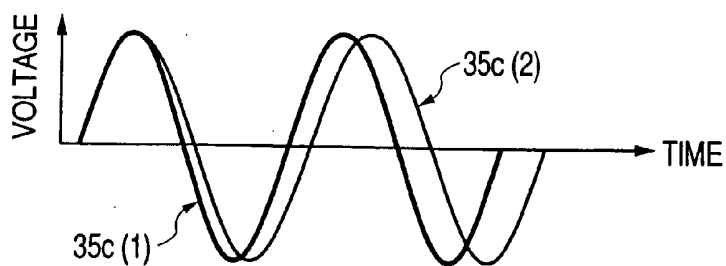

FIG. 30

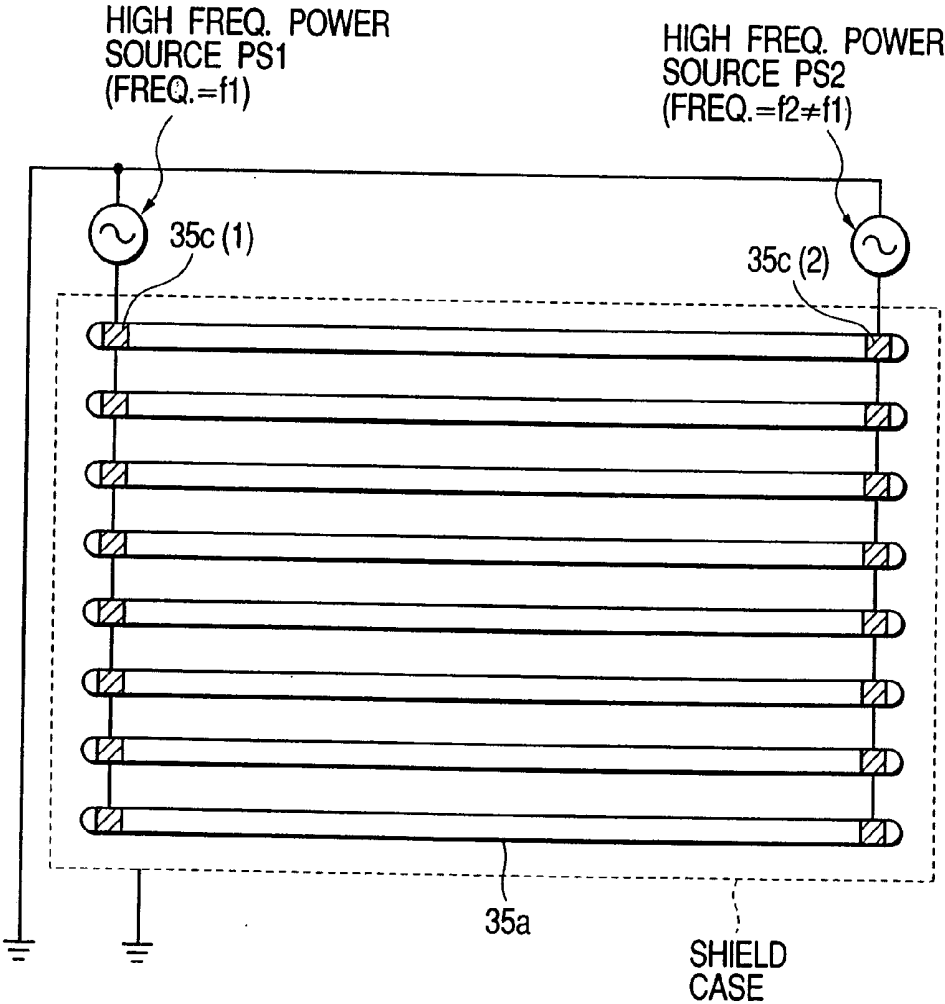

FIG. 31A

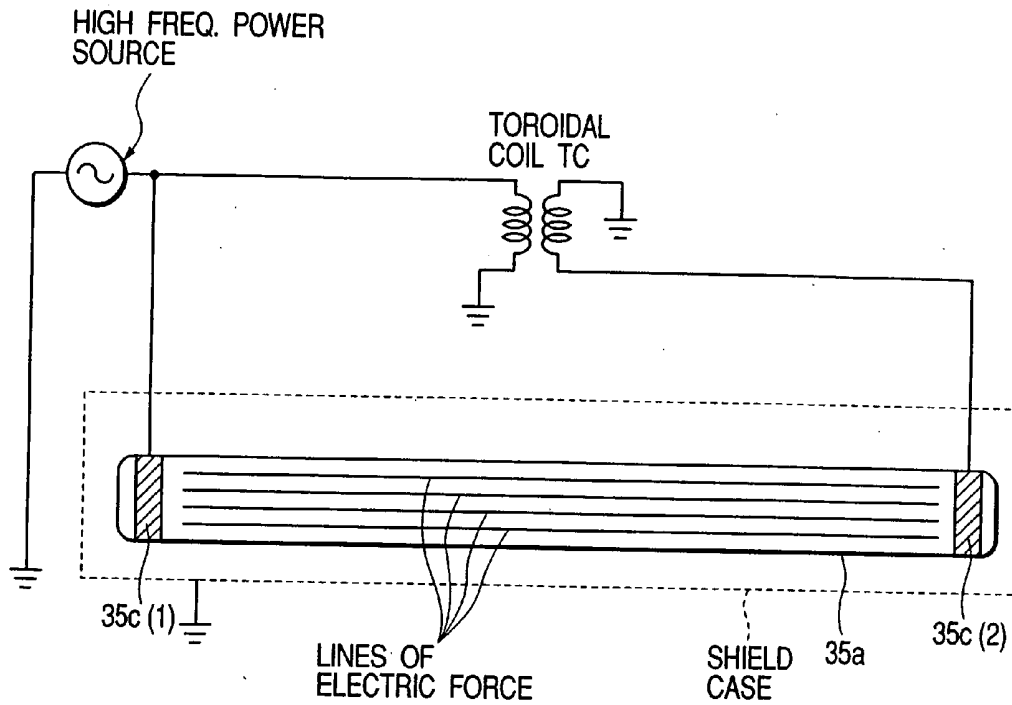
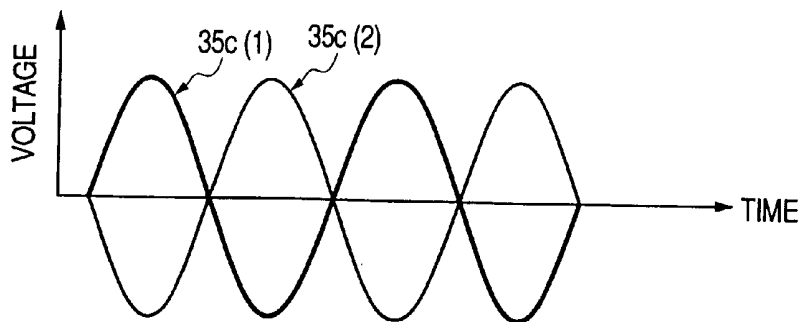
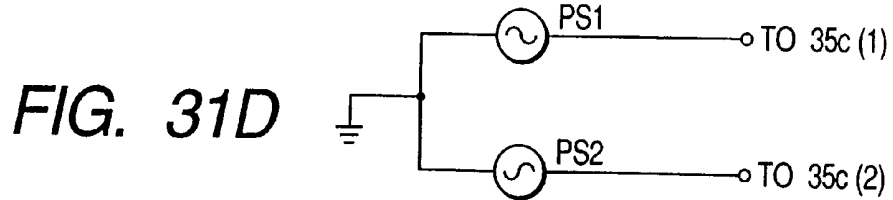
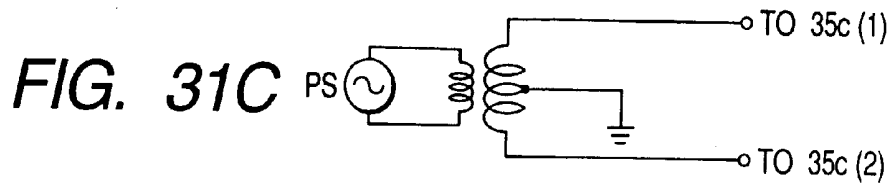

FIG. 31B





VOLTAGES FROM POWER SOURCES PS1
AND PS2 ARE OPPOSITE IN PHASE

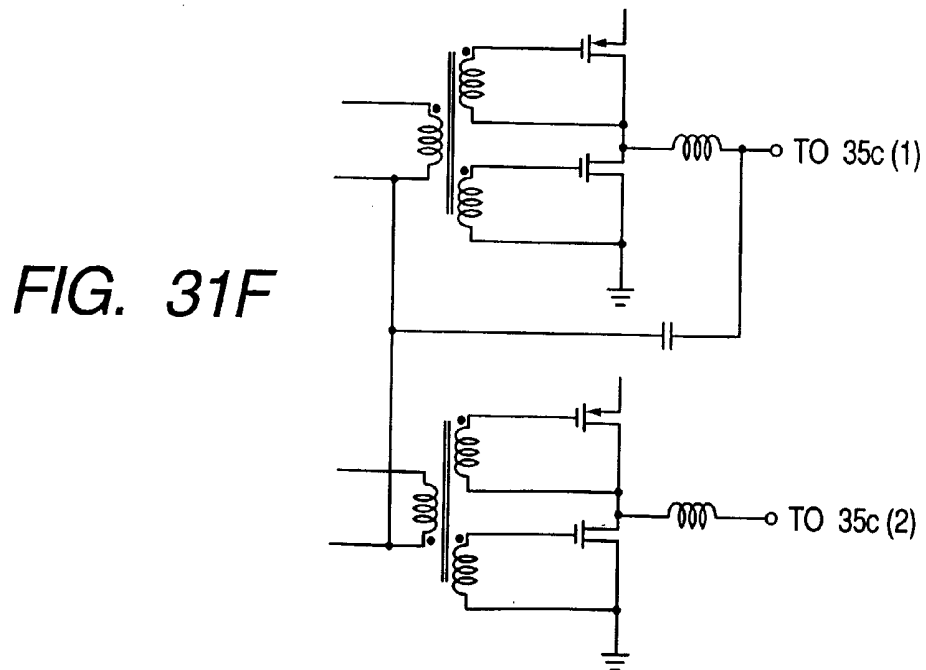
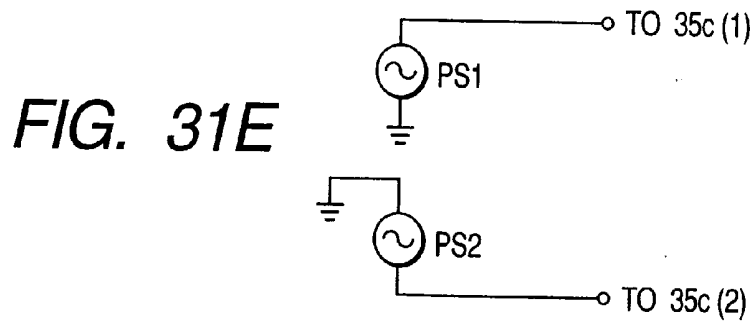

FIG. 32A

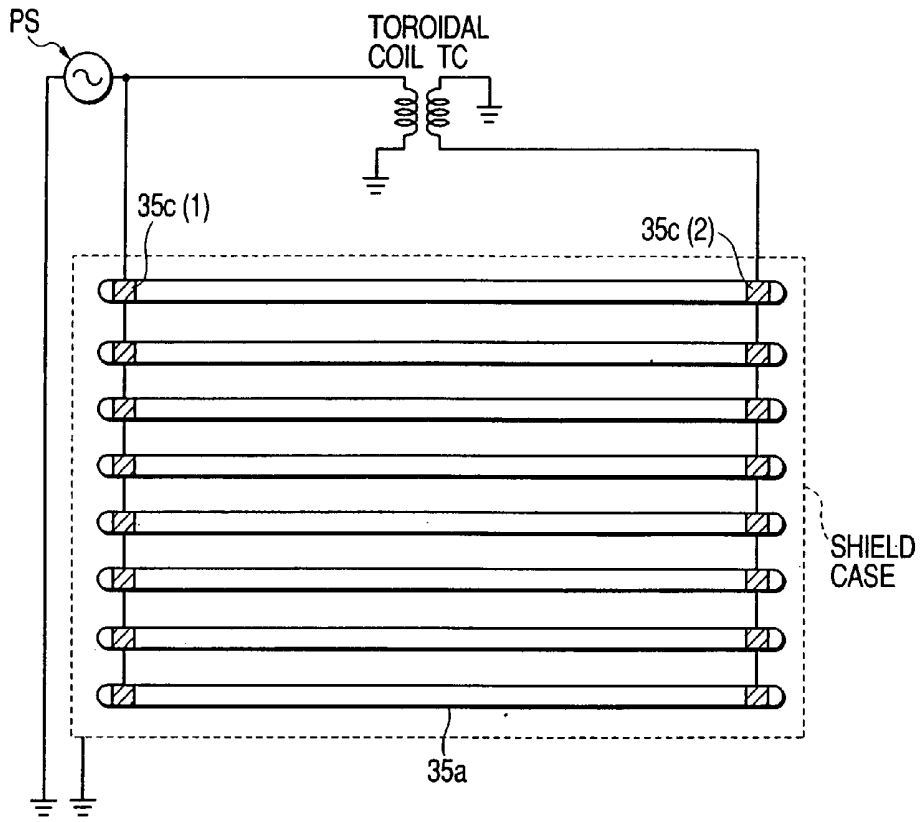

FIG. 32B

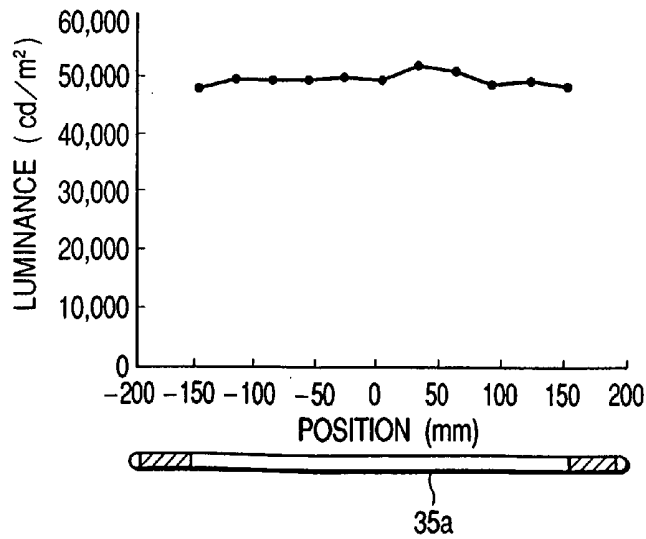

FIG. 33A

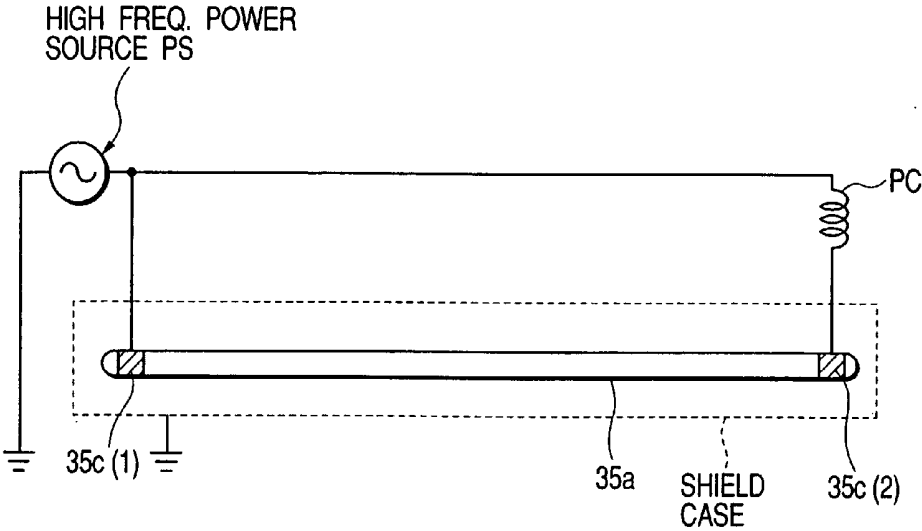

FIG. 33B

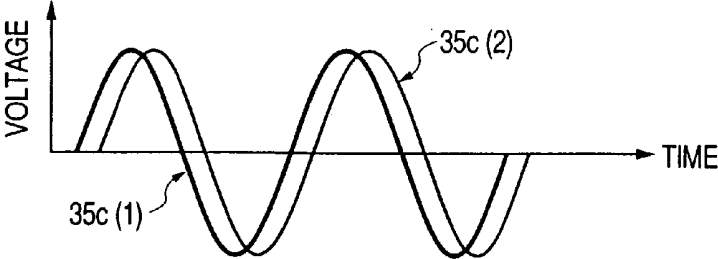

FIG. 34

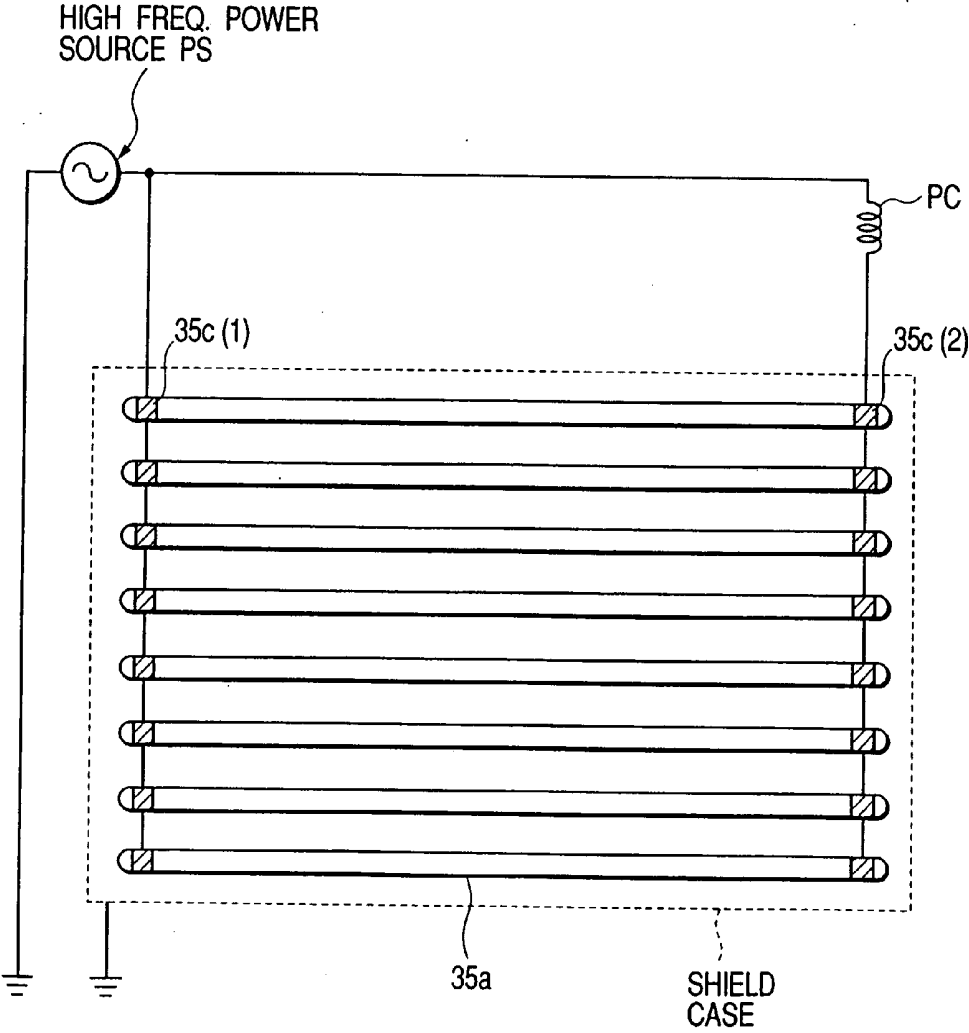

FIG. 35A

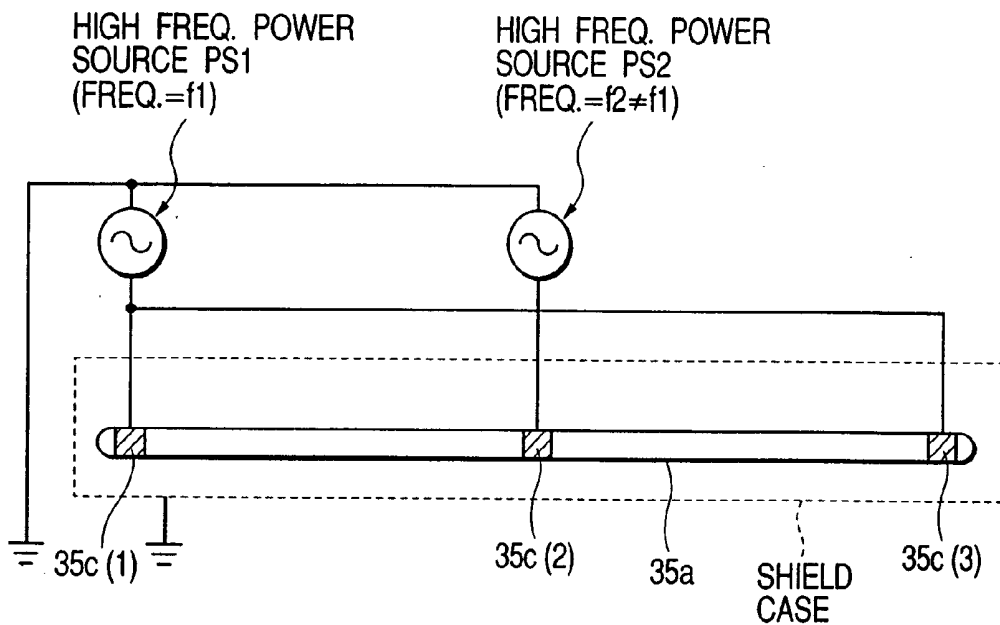

FIG. 35B

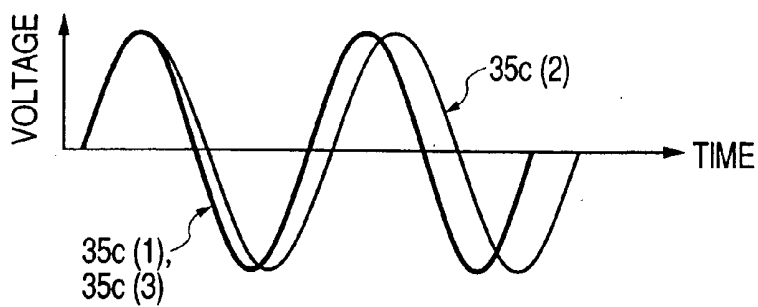

FIG. 36

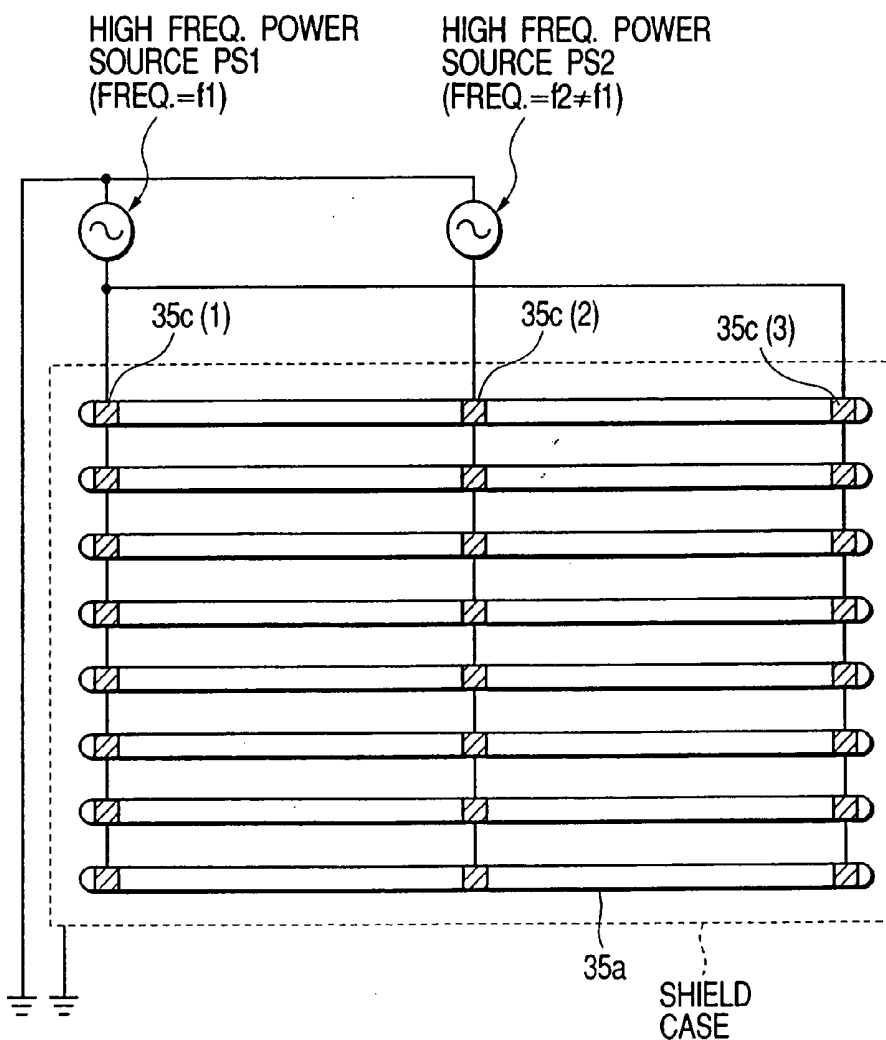

FIG. 37A

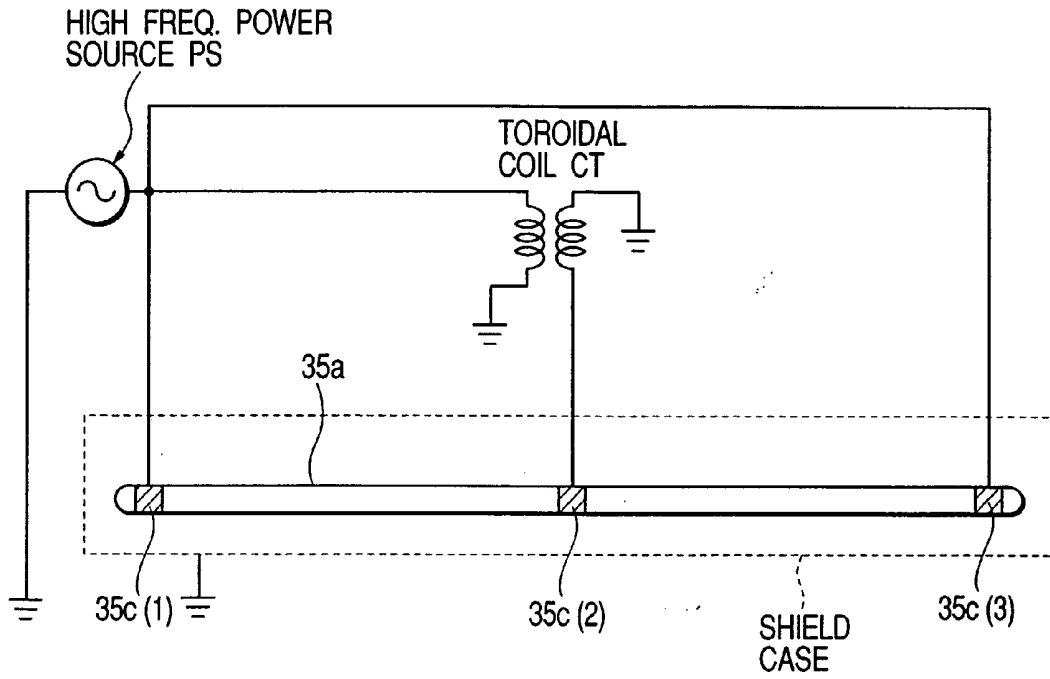

FIG. 37B

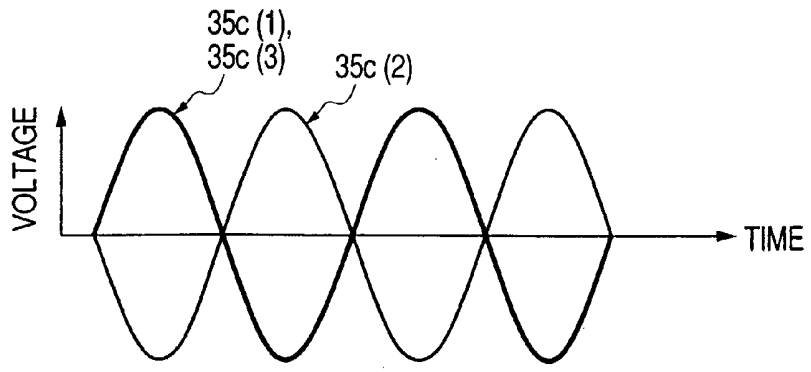

FIG. 38

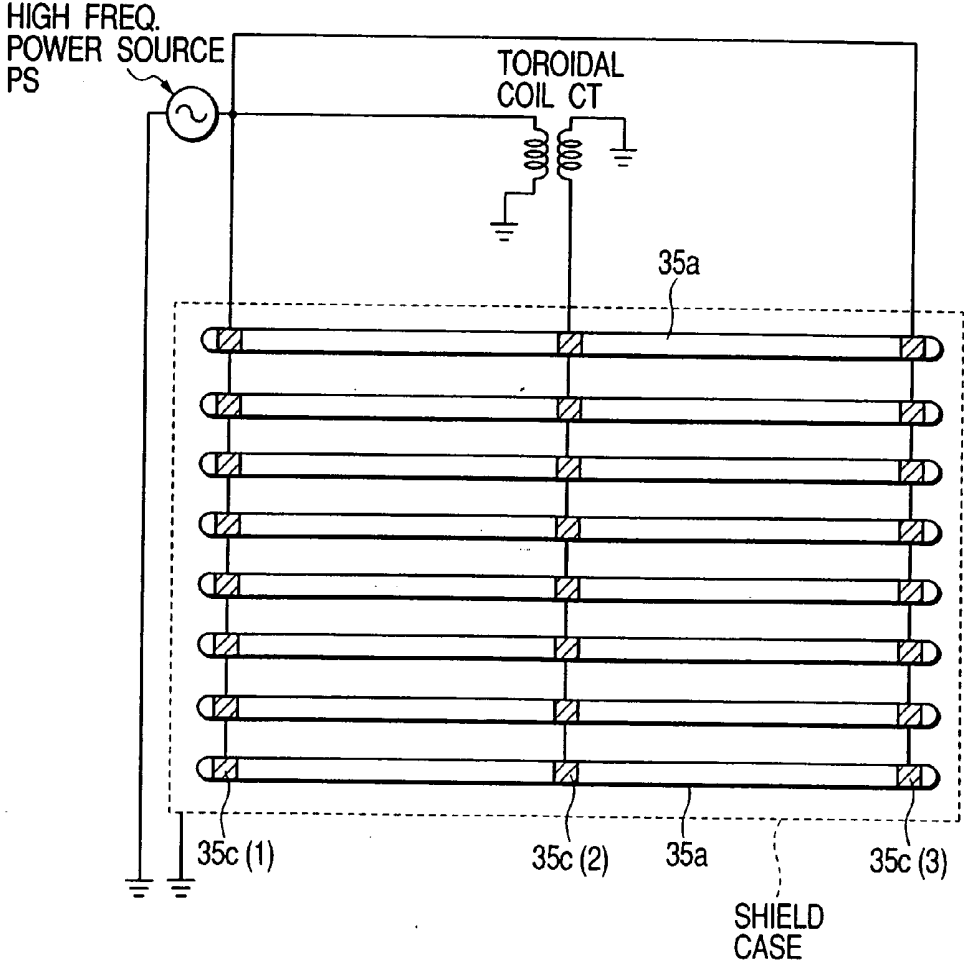

FIG. 39A

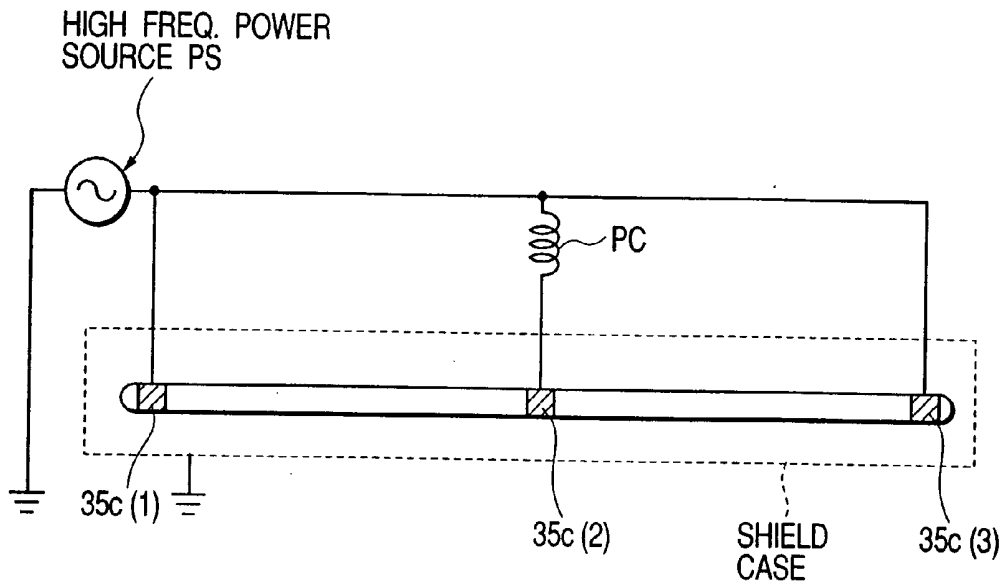

FIG. 39B

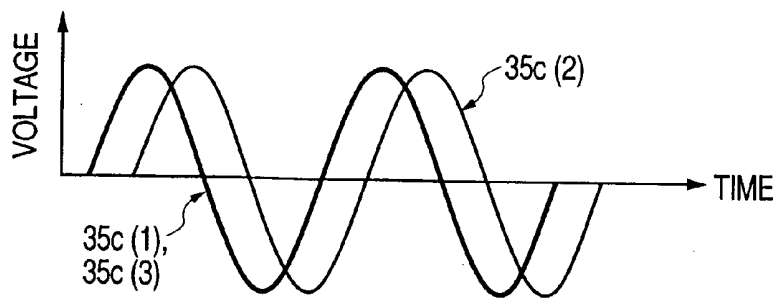

FIG. 40

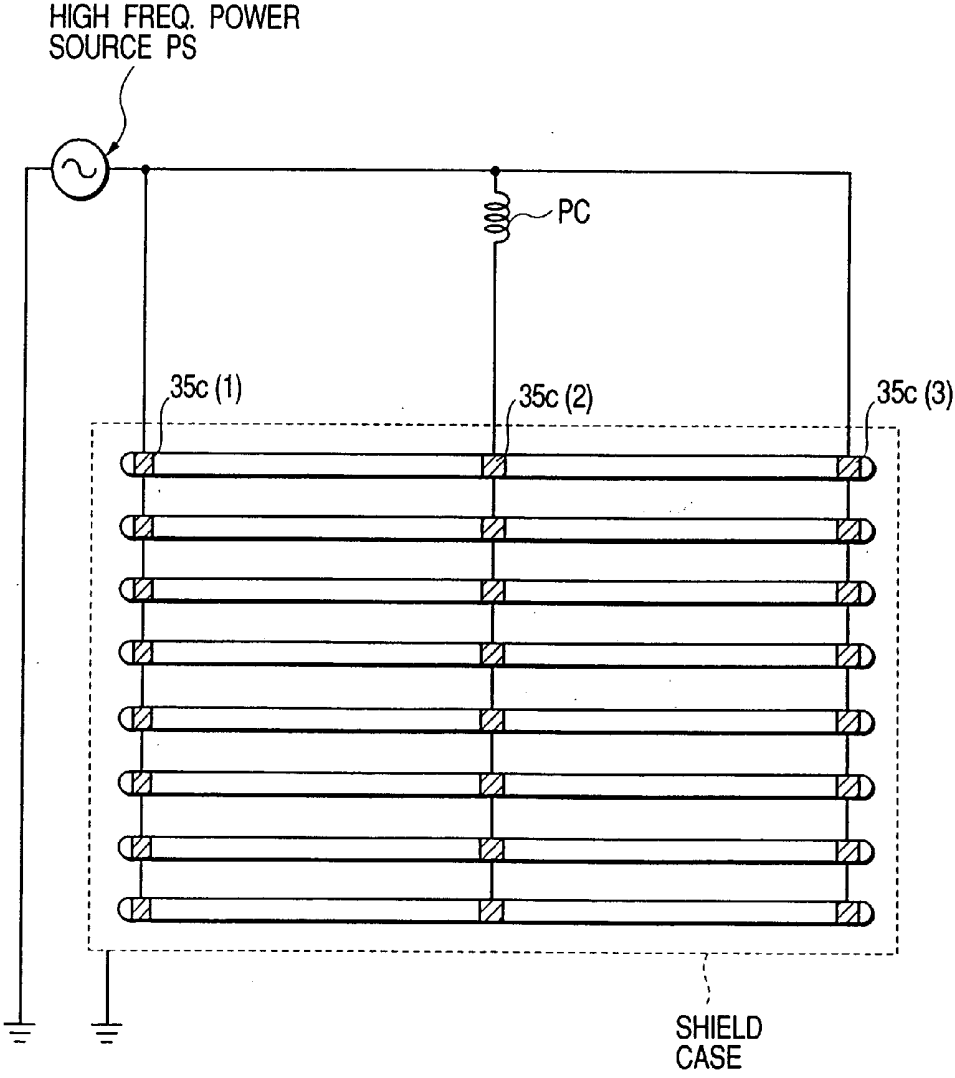

FIG. 41A

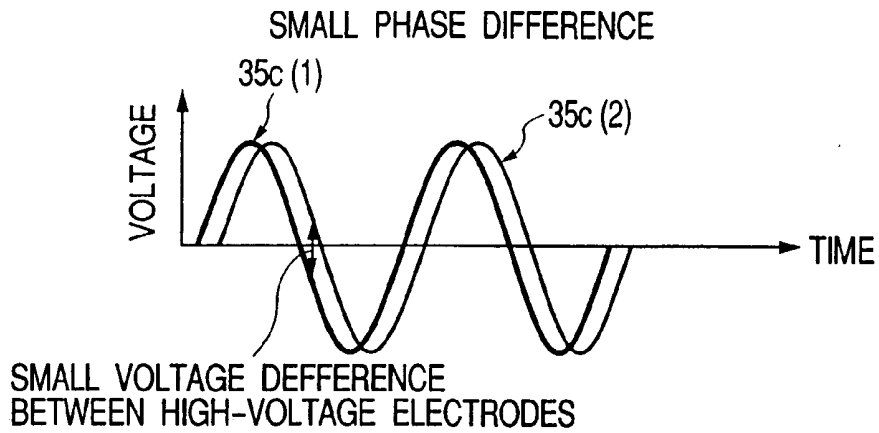

FIG. 41B

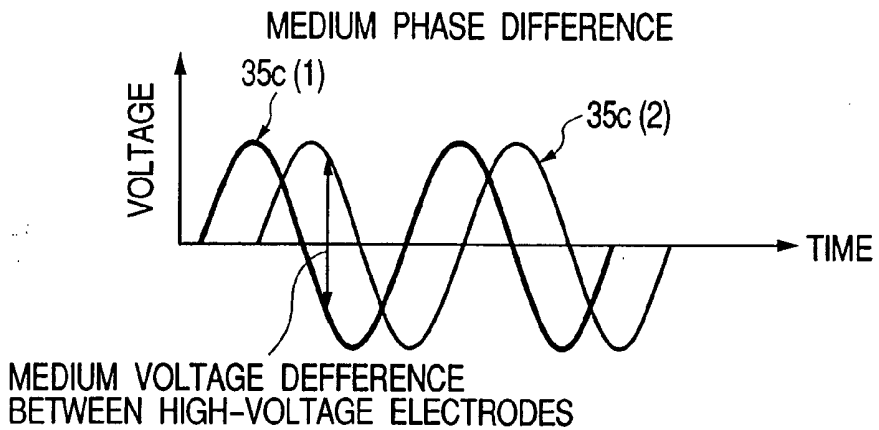

FIG. 41C

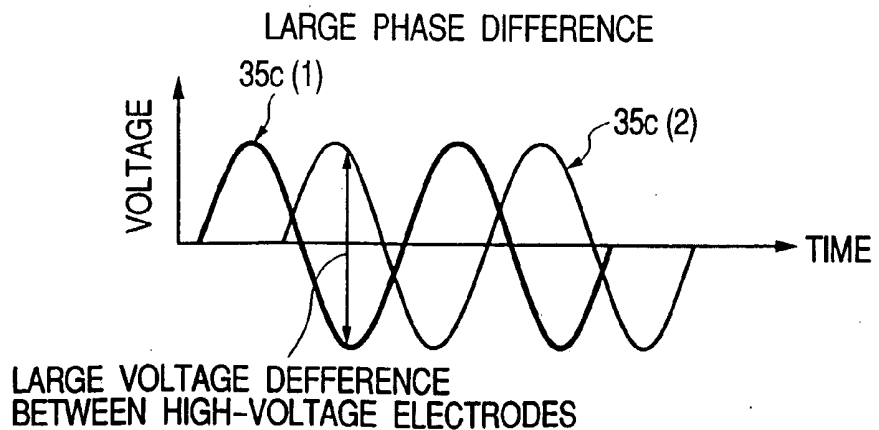

FIG. 42A

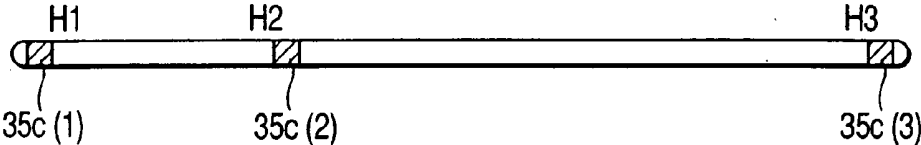

FIG. 42B

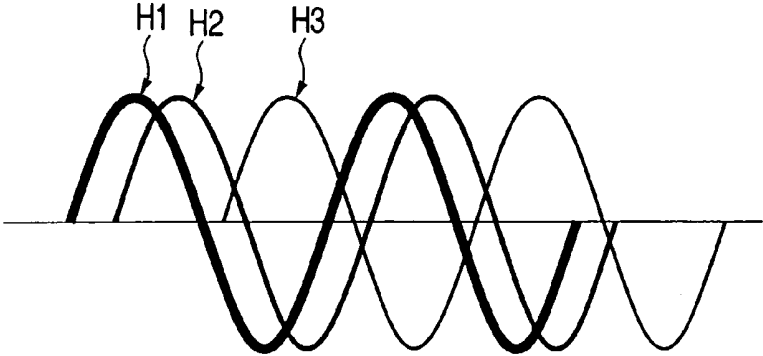

FIG. 43A

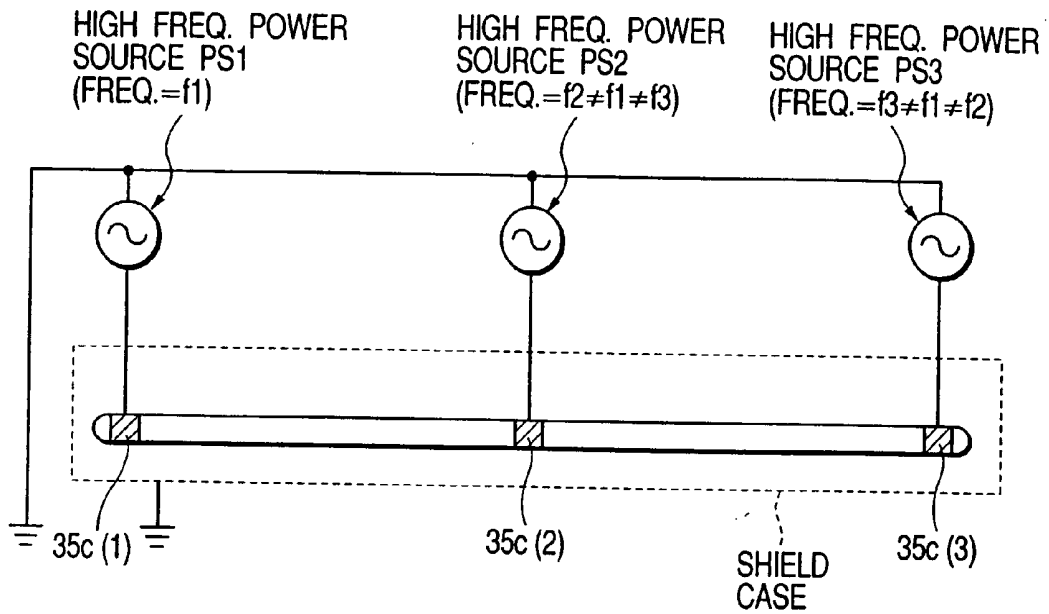

FIG. 43B

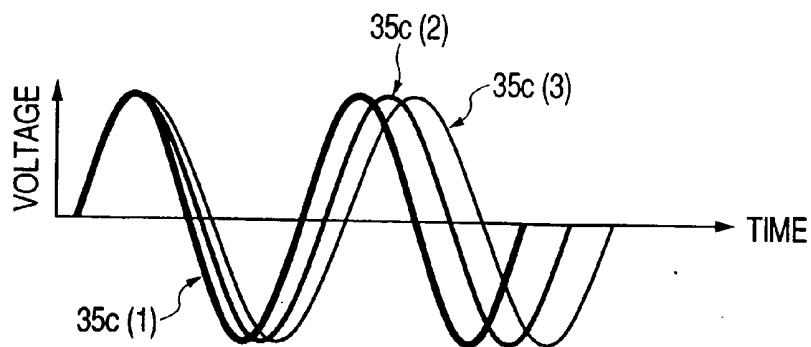

FIG. 44A

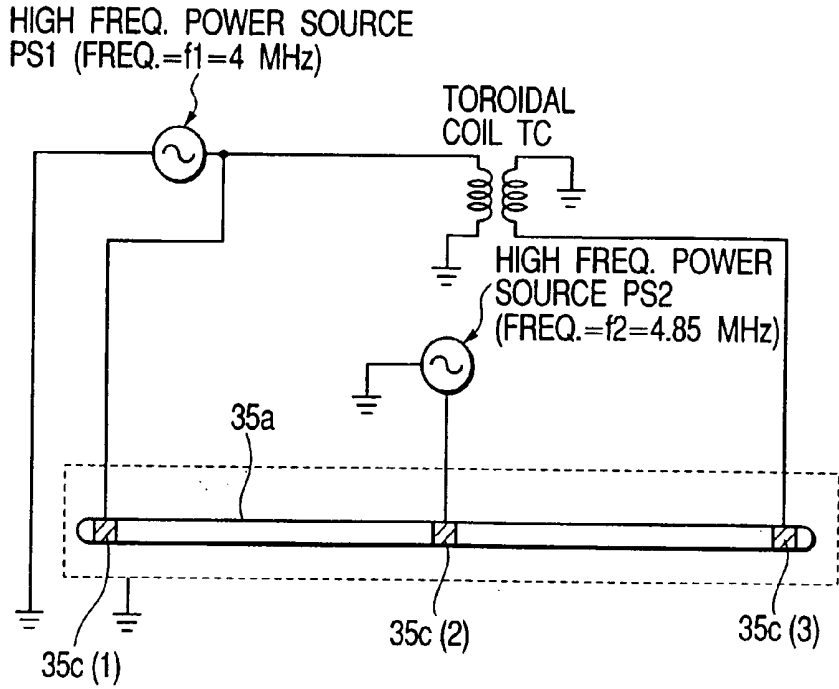

FIG. 44B

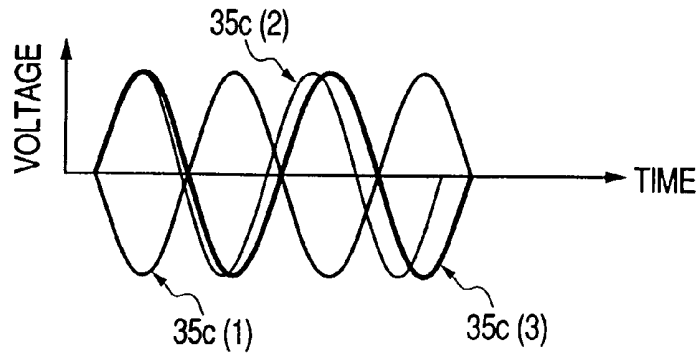

FIG. 44C

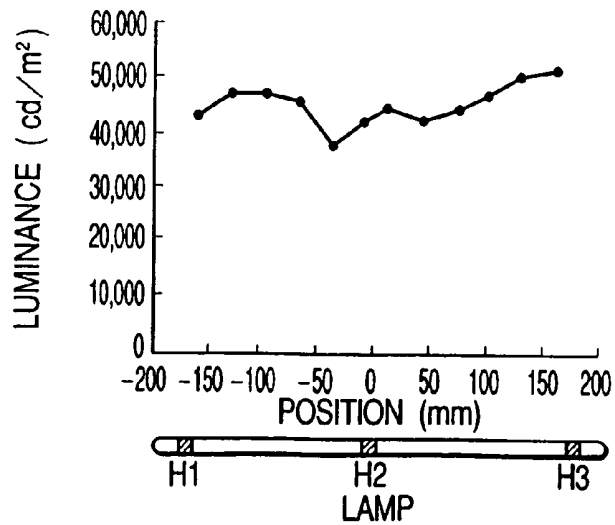

FIG. 45A

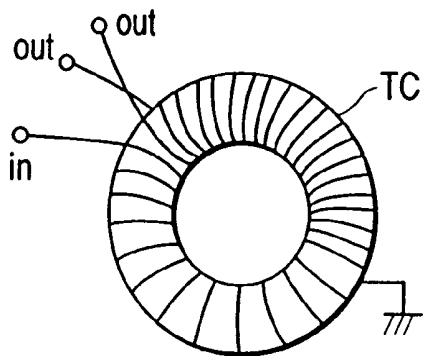

FIG. 45B

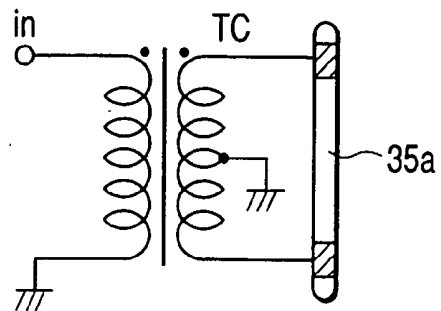

FIG. 46A

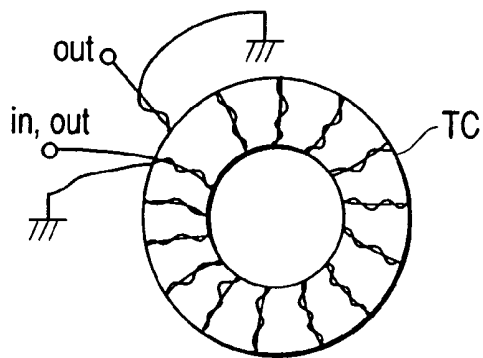

FIG. 46B

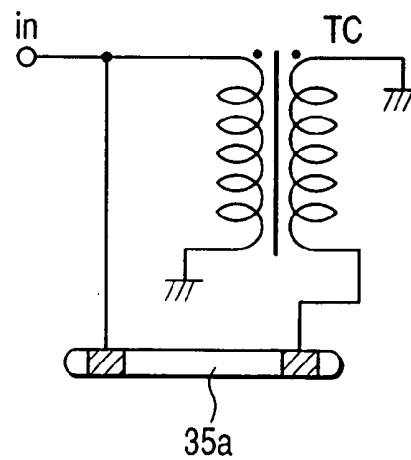

FIG. 47

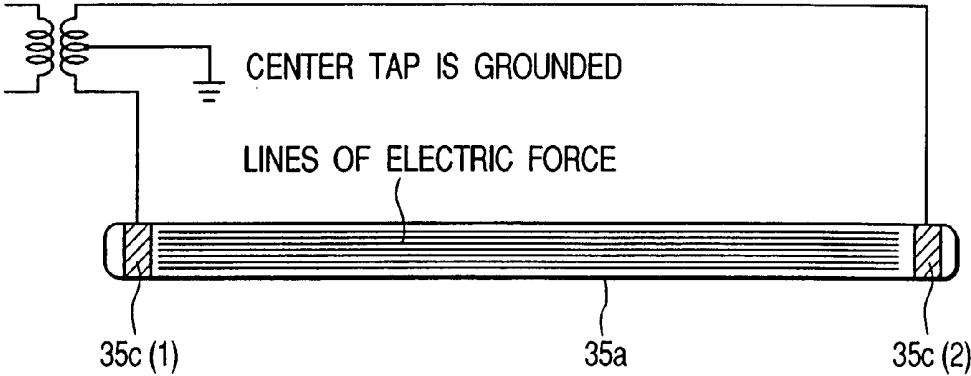

FIG. 48

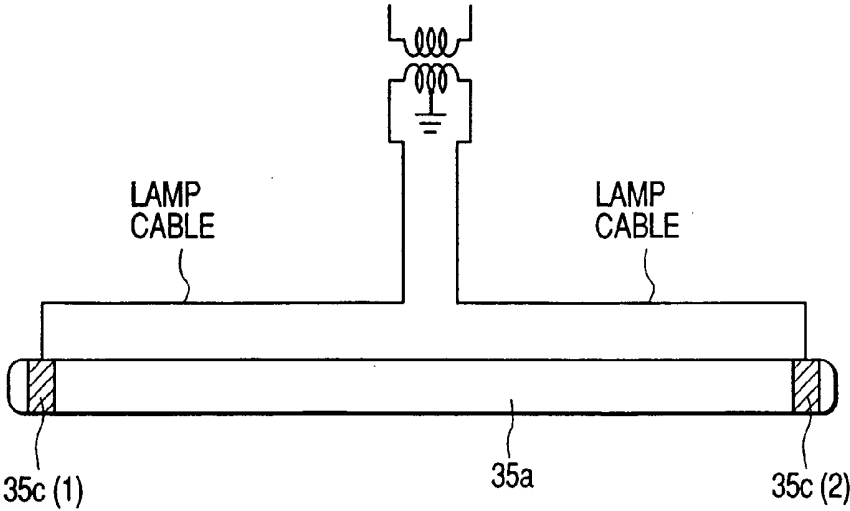

FIG. 49

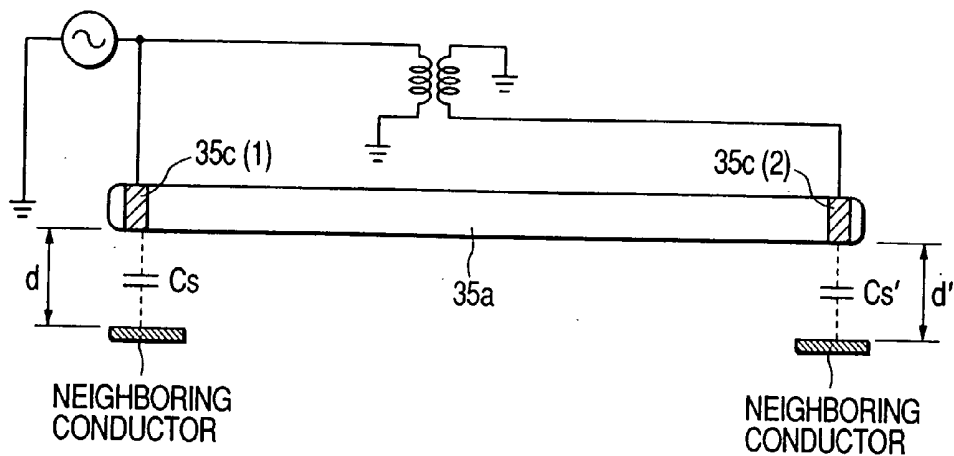

FIG. 50

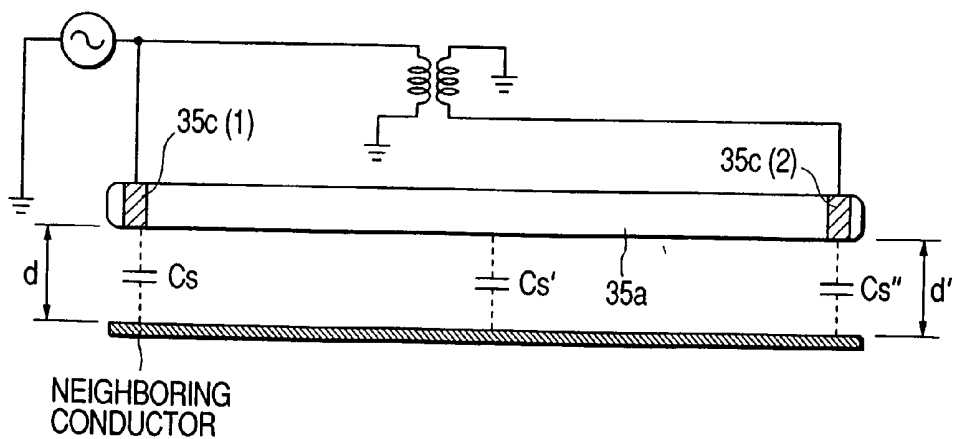
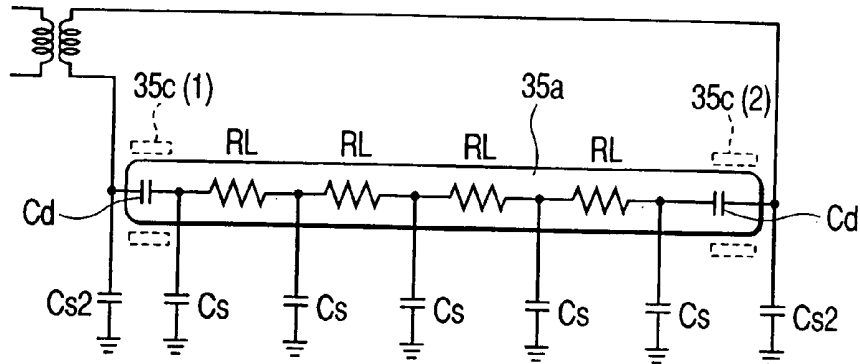

FIG. 51



RL: RESISTANCE OF LIGHT PRODUCING PORTION
 Cd: CAPACITANCE FORMED BY EXTERNAL ELECTRODES 35c (1), 35c (2)
 Cs: STRAY CAPACITANCE

FIG. 52A

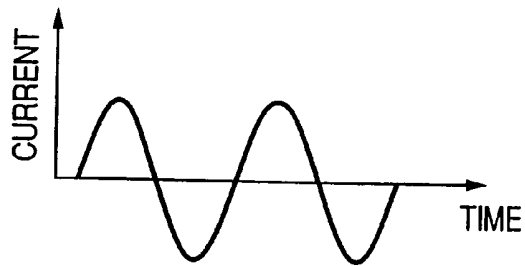

FIG. 52B

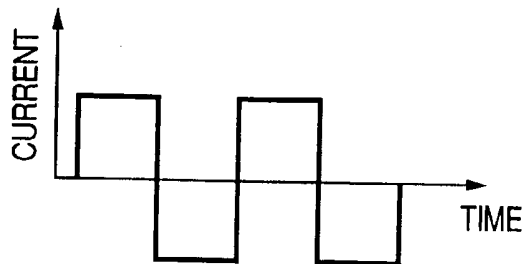
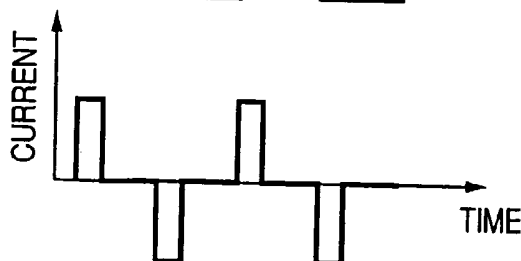

FIG. 52C



LIQUID CRYSTAL DISPLAY DEVICE HAVING AN IMPROVED BACKLIGHT

BACKGROUND OF THE INVENTION

[0001] The present invention relates to a liquid crystal display device, and in particular to a liquid crystal display device comprising a liquid crystal display panel and a backlight disposed behind the liquid crystal display panel.

[0002] The liquid crystal display panel comprises an envelope formed by two opposing transparent substrates, a liquid crystal layer sandwiched between the transparent substrates and a large number of pixels arranged over the area of the liquid crystal layer.

[0003] Each pixel is only capable of controlling the amount of light passing through the liquid crystal material associated with it, and does not generate no light of its own, and therefore, usually a backlight is disposed behind the liquid crystal display panel.

[0004] The backlight is provided with a light diffusing plate and a light reflecting plate or the like in addition to a light source so as to project a uniform light over the liquid crystal display panel.

[0005] Used as the light source is a cold cathode discharge tube (CFL) of a length approximately equal to that of a side of the liquid crystal display panel. The cold-cathode discharge tube serves as a light-generating element with two electrodes brought through its two ends being supplied with a voltage thereacross.

SUMMARY OF THE INVENTION

[0006] The lifetime of the light source was not sufficient, and consequently, it was no exaggeration to say that the lifetime of the liquid crystal display device of the above configuration is determined by that of its light source.

[0007] During operation of the cold-cathode discharge tube, a material of electrodes within the discharge tube is sputtered and is deposited on the inner wall of the discharge tube. This deposit can be perceived as black matters from the outside also.

[0008] The electrode material deposited on the tube wall mixes with mercury within the discharge tube to form an alloy (an amalgam), and then consumption of the mercury ends the life of the cold-cathode discharge tube.

[0009] The present invention was made based upon this fact, and it is an object of the present invention to provide a liquid crystal display device capable of improving its lifetime, and it is another object of the present invention to provide a liquid crystal display device capable of providing a uniform luminance over the display area.

[0010] The following explains briefly the summary of representative ones of the inventions disclosed in this specification.

[0011] In accordance with an embodiment of the present invention, there is provided a liquid crystal display device including a liquid crystal display panel having a liquid crystal layer sandwiched between a pair of transparent substrates, at least one of the pair of transparent substrates having patterned electrodes on an inner surface thereof, and a backlight disposed behind the liquid crystal display panel,

the backlight comprising: at least one discharge tube including a sealed-off transparent tube, a phosphor film formed on an inner surface of the sealed-off transparent tube, and a discharge gas within the sealed-off transparent tube; and a plurality of electrodes spaced in a direction of an axis of the sealed-off transparent tube and positioned at least partially around a circumference of the sealed-off transparent tube, at least two adjacent ones of the plurality of electrodes being supplied with alternating voltages different in frequency from each other, respectively.

[0012] In accordance with another embodiment of the present invention, there is a liquid crystal display device including a liquid crystal display panel having a liquid crystal layer sandwiched between a pair of transparent substrates, at least one of the pair of transparent substrates having patterned electrodes on an inner surface thereof, and a backlight disposed behind the liquid crystal display panel, the backlight comprising: at least one discharge tube including a sealed-off transparent tube, a phosphor film formed on an inner surface of the sealed-off transparent tube, and a discharge gas within the sealed-off transparent tube; and a plurality of electrodes spaced in a direction of an axis of the sealed-off transparent tube and positioned at least partially around a circumference of the sealed-off transparent tube, at least two adjacent ones of the plurality of electrodes being supplied with voltages of a frequency not lower than 1 MHz and opposite in phase from each other, respectively.

[0013] In accordance with another embodiment of the present invention, there is provided a liquid crystal display device including a liquid crystal display panel having a liquid crystal layer sandwiched between a pair of transparent substrates, at least one of the pair of transparent substrates having patterned electrodes on an inner surface thereof, and a backlight disposed behind the liquid crystal display panel, the backlight comprising: at least one discharge tube including a sealed-off transparent tube, a phosphor film formed on an inner surface of the sealed-off transparent tube, and a discharge gas within the sealed-off transparent tube; and a plurality of electrodes spaced in a direction of an axis of the sealed-off transparent tube and positioned at least partially around a circumference of the sealed-off transparent tube, at least two adjacent ones of the plurality of electrodes being supplied with alternating voltages having different phases from each other, respectively, a phase difference therebetween being greater than 0 degrees, but less than 180 degrees, or being greater than 180 degrees, but less than 360 degrees.

[0014] The liquid crystal display devices of the above configurations are capable of improving their lifetime by preventing sputtering of the electrode material, and also are capable of generating light having an approximately uniform luminance distribution between the electrodes of the discharge tube supplied with high-frequency voltages.

BRIEF DESCRIPTION OF THE DRAWINGS

[0015] In the accompanying drawings, in which like reference numerals designate similar components throughout the figures, and in which:

[0016] **FIG. 1** is an equivalent circuit for illustrating an embodiment of the liquid crystal display device in accordance with the present invention;

[0017] FIG. 2 is an exploded perspective view of an embodiment of the liquid crystal display device in accordance with the present invention;

[0018] FIG. 3 is a plan view of an embodiment of a pixel in the liquid crystal display device in accordance with the present invention;

[0019] FIG. 4 is an exploded perspective view of an embodiment of a backlight in the liquid crystal display device in accordance with the present invention;

[0020] FIG. 5 is a perspective view of an embodiment of a light source incorporated in a backlight in the liquid crystal display device in accordance with the present invention;

[0021] FIG. 6A is a longitudinal cross-sectional view of a discharge tube constituting a light source in the liquid crystal display device in accordance with the present invention, and FIG. 6B is a transverse cross-sectional view taken along line VIB-VIB of FIG. 6A;

[0022] FIGS. 7A, 7B and 7C are luminance distributions of a light source in the liquid crystal display device in accordance with the present invention for supply voltages of 800 Vp-p, 900 Vp-p and 1000 Vp-p, respectively;

[0023] FIG. 8A is a plan view of an embodiment of a backlight in the liquid crystal display device in accordance with the present invention, and FIG. 8B is a cross-sectional view taken along line VIII B-VIII B of FIG. 8A;

[0024] FIG. 9 is a graph showing a relationship between average luminances of a backlight and frequencies of its power source in the liquid crystal display device in accordance with the present invention;

[0025] FIG. 10 is a perspective view of an embodiment of a resin frame in the liquid crystal display device in accordance with the present invention;

[0026] FIG. 11 is an illustration of an embodiment of a high-frequency power source board disposed on the rear surface of the resin frame in the liquid crystal display device in accordance with the present invention;

[0027] FIG. 12A is a plan view of an assembly of a liquid crystal display device in accordance with the present invention, FIG. 12B is a top-side view of the assembly of FIG. 12A, FIG. 12C is a bottom-side view of the assembly of FIG. 12A, FIG. 12D is a left-side view of the assembly of FIG. 12A, and FIG. 12E is a right-side view of the assembly of FIG. 12A;

[0028] FIG. 13 is a cross-sectional view of another embodiment of the liquid crystal display device in accordance with the present invention;

[0029] FIG. 14A is a longitudinal cross-sectional view of another embodiment of a light source in the liquid crystal display device in accordance with the present invention, FIG. 14A1 is a cross-sectional view taken along line XIVA1-XIVA1 of FIG. 14A;

[0030] FIG. 14B is a longitudinal cross-sectional view of still another embodiment of a light source in the liquid crystal display device in accordance with the present invention, FIG. 14B1 is a cross-sectional view taken along line XIVB1-XIVB1 of FIG. 14B;

[0031] FIG. 14C is a longitudinal cross-sectional view of still another embodiment of a light source in the liquid crystal display device in accordance with the present invention, FIG. 14C1 is a cross-sectional view taken along line XIVC1-XIVC1 of FIG. 14C;

[0032] FIG. 15A is an illustration for explaining another embodiment of a light source in the liquid crystal display device in accordance with the present invention, FIG. 15B is an illustration for explaining still another embodiment of a light source in the liquid crystal display device in accordance with the present invention, FIG. 15C is an illustration for explaining still another embodiment of a light source in the liquid crystal display device in accordance with the present invention, and FIG. 15D is an illustration for explaining still another embodiment of a light source in the liquid crystal display device in accordance with the present invention;

[0033] FIG. 16A is an illustration for explaining another embodiment of a light source in the liquid crystal display device in accordance with the present invention, FIG. 16B is an illustration for explaining still another embodiment of a light source in the liquid crystal display device in accordance with the present invention, FIG. 16C is an illustration for explaining still another embodiment of a light source in the liquid crystal display device in accordance with the present invention, and FIG. 16D is an illustration for explaining still another embodiment of a light source in the liquid crystal display device in accordance with the present invention;

[0034] FIG. 17A is an illustration for explaining another embodiment of a light source in the liquid crystal display device in accordance with the present invention, FIG. 17B is an illustration for explaining still another embodiment of a light source in the liquid crystal display device in accordance with the present invention, and FIG. 17C is an illustration for explaining still another embodiment of a light source in the liquid crystal display device in accordance with the present invention;

[0035] FIG. 18 is an illustration for explaining another embodiment of a light source in the liquid crystal display device in accordance with the present invention;

[0036] FIG. 19 is an illustration for explaining another embodiment of a light source in the liquid crystal display device in accordance with the present invention;

[0037] FIG. 20A is an illustration for explaining driving of a light source in the liquid crystal display device in accordance with the present invention, and FIG. 20B is an equivalent circuit of the driving;

[0038] FIG. 21 is an illustration for explaining behaviors of positive ions and electrons within a light source in the liquid crystal display device in accordance with the present invention;

[0039] FIG. 22 is an illustration for explaining occurrence of leakage of lines of electric force in a light source in the liquid crystal display device in accordance with the present invention;

[0040] FIG. 23A is an illustration for explaining another embodiment of a light source, treated as one discharge tube, in the liquid crystal display device in accordance with the present invention, and FIG. 23B shows waveforms of associated driving voltages;

[0041] FIG. 24A is an illustration for explaining another embodiment of a light source, assembled as a backlight, in the liquid crystal display device in accordance with the present invention, and FIG. 24B shows a distribution of its luminance;

[0042] FIG. 25A is an illustration for explaining another embodiment of a light source, treated as one discharge tube, in the liquid crystal display device in accordance with the present invention, and FIG. 25B shows waveforms of associated driving voltages;

[0043] FIG. 26A is an illustration for explaining another embodiment of a light source, assembled as a backlight, in the liquid crystal display device in accordance with the present invention, and FIG. 26B shows a distribution of its luminance;

[0044] FIG. 27A is an illustration for explaining another embodiment of a light source, treated as one discharge tube, in the liquid crystal display device in accordance with the present invention, and FIG. 27B shows waveforms of associated driving voltages;

[0045] FIG. 28 is an illustration for explaining another embodiment of a light source, assembled as a backlight, in the liquid crystal display device in accordance with the present invention;

[0046] FIG. 29A is an illustration for explaining another embodiment of a light source, treated as one discharge tube, in the liquid crystal display device in accordance with the present invention, and FIG. 29B shows waveforms of associated driving voltages;

[0047] FIG. 30 is an illustration for explaining another embodiment of a light source, assembled as a backlight, in the liquid crystal display device in accordance with the present invention;

[0048] FIG. 31A is an illustration for explaining another embodiment of a light source, treated as one discharge tube, in the liquid crystal display device in accordance with the present invention, FIG. 31B shows waveforms of associated driving voltages, and FIGS. 31C-31F show circuit configurations usable instead of the circuit configuration of FIG. 31A;

[0049] FIG. 32A is an illustration for explaining another embodiment of a light source, assembled as a backlight, in the liquid crystal display device in accordance with the present invention, and FIG. 32B shows a distribution of its luminance;

[0050] FIG. 33A is an illustration for explaining another embodiment of a light source, treated as one discharge tube, in the liquid crystal display device in accordance with the present invention, and FIG. 33B shows waveforms of associated driving voltages;

[0051] FIG. 34 is an illustration for explaining another embodiment of a light source, assembled as a backlight, in the liquid crystal display device in accordance with the present invention;

[0052] FIG. 35A is an illustration for explaining another embodiment of a light source, treated as one discharge tube, in the liquid crystal display device in accordance with the present invention, and FIG. 35B shows waveforms of associated driving voltages;

[0053] FIG. 36 is an illustration for explaining another embodiment of a light source, assembled as a backlight, in the liquid crystal display device in accordance with the present invention;

[0054] FIG. 37A is an illustration for explaining another embodiment of a light source, treated as one discharge tube, in the liquid crystal display device in accordance with the present invention, and FIG. 37B shows waveforms of associated driving voltages;

[0055] FIG. 38 is an illustration for explaining another embodiment of a light source, assembled as a backlight, in the liquid crystal display device in accordance with the present invention;

[0056] FIG. 39A is an illustration for explaining another embodiment of a light source, treated as one discharge tube, in the liquid crystal display device in accordance with the present invention, and FIG. 39B shows waveforms of associated driving voltages;

[0057] FIG. 40 is an illustration for explaining another embodiment of a light source, assembled as a backlight, in the liquid crystal display device in accordance with the present invention;

[0058] FIGS. 41A, 41B and 41C are illustrations for explaining driving of a light source in the liquid crystal display device in accordance with the present invention in the case of small, medium and large phase differences between two high-frequency voltages applied to two high-voltage electrodes, respectively;

[0059] FIG. 42A is an illustration for explaining another embodiment of a light source in the liquid crystal display device in accordance with the present invention, and FIG. 42B shows waveforms of associated driving voltages;

[0060] FIG. 43A is an illustration for explaining another embodiment of a light source in the liquid crystal display device in accordance with the present invention, and FIG. 43B shows waveforms of associated driving voltages;

[0061] FIG. 44A is an illustration for explaining another embodiment of a light source in the liquid crystal display device in accordance with the present invention, FIG. 44B shows waveforms of associated driving voltages, and FIG. 44C shows a distribution of luminance of the light source;

[0062] FIG. 45A is an illustration for explaining a toroidal coil used for phase reversal of a driving voltage, and FIG. 45B is an illustration for explaining an embodiment of a light source in the liquid crystal display device in accordance with the present invention employing the toroidal coil;

[0063] FIG. 46A is an illustration for explaining an improved toroidal coil used for phase reversal of a driving voltage, and FIG. 46B is an illustration for explaining an embodiment of a light source in the liquid crystal display device in accordance with the present invention employing the improved toroidal coil;

[0064] FIG. 47 is an illustration for explaining another embodiment of a light source in the liquid crystal display device in accordance with the present invention;

[0065] FIG. 48 is an illustration for explaining another embodiment of a light source in the liquid crystal display device in accordance with the present invention;

[0066] FIG. 49 is an illustration for explaining another embodiment of a light source in the liquid crystal display device in accordance with the present invention;

[0067] FIG. 50 is an illustration for explaining another embodiment of a light source in the liquid crystal display device in accordance with the present invention;

[0068] FIG. 51 is an illustration for explaining another embodiment of a light source in the liquid crystal display device in accordance with the present invention; and

[0069] FIGS. 52A-52C are illustrations for explaining embodiments of a waveform of a driving voltage of a light source in the liquid crystal display device in accordance with the present invention, respectively.

DETAILED DESCRIPTION OF THE PREFERRED EMBODIMENTS

[0070] Now, embodiments of the liquid crystal display device in accordance with the present invention will be explained by reference to the drawings.

Embodiment 1

[0071] Equivalent Circuit of the Liquid Crystal Display Device

[0072] FIG. 1 shows an equivalent circuit of an embodiment of the liquid crystal display device in accordance with the present invention. FIG. 1 also indicates an actual geometrical arrangement of components of the liquid crystal display device. In this embodiment, the present invention is applied to a liquid crystal display device of the so-called horizontal electric field type (the in-plane switching type) known for its wide viewing angles.

[0073] A liquid crystal display panel 1 comprises an envelope formed by two opposing transparent substrates 1A, 1B, and a liquid crystal layer sandwiched between the transparent substrates 1A, 1B. One transparent substrate shown as a lower substrate in FIG. 1, a matrix substrate 1A, is made slightly larger than the other transparent substrate shown as an upper substrate in FIG. 1, a color filter substrate 1B, and the bottom and right sides of the matrix substrate 1A are approximately with those of the color filter substrate 1B, respectively, as shown in FIG. 1. As a result, as shown in FIG. 1, the left and top peripheral portions of the transparent substrate 1A extend beyond the corresponding edges of the other transparent substrate 1B. As described subsequently, gate driving circuits 5 and drain driving circuits 6 are mounted on the left and top peripheral portions of the transparent substrate 1A.

[0074] Pixels 2 (one of which is shown) are disposed in a matrix fashion in the overlapping region of the transparent substrates 1A and 1B. Each of the pixels 2 is formed in a region surrounded by two adjacent ones of scanning signal lines 3 extending in an x direction and arranged in a y direction in FIG. 1 and two adjacent ones of video signal lines 4 extending in the y direction and arranged in the x direction, and is provided with at least a switching element TFT driven by a scanning signal supplied by a corresponding one of the scanning signal lines 3 and a pixel electrode supplied with a video signal from a corresponding one of the video signal lines 4 via the switching element TFT.

[0075] As described above, the liquid crystal display device of this embodiment is of the so-called horizontal electric field type, and therefore each of the pixels 2 is provided with a counter electrode and an additional capacitance element in addition to the switching element TFT and the pixel electrode as explained in detail subsequently.

[0076] One end (a left end in FIG. 1) of each of the scanning signal lines 3 extends beyond the edge of the transparent substrate 1B, and is connected to a corresponding one of the output terminals of the gate driving circuits (IC) 5 mounted on the transparent substrate 1A.

[0077] The plural gate driving circuits 5 are provided, the scanning signal lines 3 are divided into groups each comprising adjacent ones of the scanning signal lines 3, and scanning lines 3 of each of the groups are connected to one of the plural gate driving circuits 5 adjacent to it.

[0078] One end (a top end in FIG. 1) of each of the video signal lines 4 extends beyond the edge of the transparent substrate 1B, and is connected to a corresponding one of the output terminals of the drain driving circuits (IC) 6 mounted on the transparent substrate 1A.

[0079] The plural drain driving circuits 6 are provided, the video signal lines 4 are divided into groups each comprising adjacent ones of the video signal lines 4, and video signal lines 4 of each of the groups are connected to one of the plural drain driving circuits 6 adjacent to it.

[0080] A printed circuit board 10 (a control board 10) is disposed adjacently to the liquid crystal display panel 1 having the gate driving circuit 5 and the drain driving circuit 6 mounted thereon, and mounts thereon a control circuit 12 for supplying input signals to the gate driving circuits 5 and the drain driving circuits 6 in addition to a power supply circuit 11 and the like.

[0081] The signals from the control circuit 12 are supplied to the gate driving circuits 5 and the drain driving circuits 6 via flexible wiring boards (a gate circuit board 15 and drain circuit boards 16A and 16B).

[0082] Disposed on the gate driving circuit 5 side of the matrix substrate 1A is the gate circuit board 15, which is a flexible wiring board, having terminals facing and connected to corresponding ones of input terminals of the gate driving circuits 5.

[0083] The gate circuit board 15 has a portion extending to the control board 10 where the gate circuit board 15 is electrically connected to the control board 10 via a connecting part 18.

[0084] Output signals from the control circuit 12 mounted on the control board 10 are supplied to the respective gate driving circuits 5 via wiring on the control substrate 10, the connecting part 18 and wiring on the gate circuit board 15.

[0085] Disposed on the drain driving circuit 6 side of the matrix substrate 1A is the drain circuit boards 16A, 16B having terminals facing and connected to corresponding ones of input terminals of the drain driving circuits 6.

[0086] The drain circuit boards 16A, 16B have portions extending to the control board 10 where the drain circuit boards 16A, 16B are electrically connected to the control board 10 via connecting parts 19A, 19B, respectively.

[0087] Output signals from the control circuit 12 mounted on the control board 10 are supplied to the respective drain driving circuits 6 via wiring on the control substrate 10, the connecting parts 19A, 19B and wiring on the drain circuit boards 16A, 16B.

[0088] The two drain circuit boards 16A and 16B are separated from each other as shown in FIG. 1. This is intended to prevent harmful influences caused by thermal expansion which are increased with an increasing length in the x direction of the drain circuit boards 16A, 16B, for example, in FIG. 1 as the size of the liquid crystal display panel 1 is made larger. The output signals from the control circuit 12 on the control board 10 are supplied to corresponding ones of the drain driving circuits 6 via the connecting part 19A of the drain circuit board 16A and the connecting part 19B of the drain circuit board 16B.

[0089] Video signals are supplied to the control board 10 from a video signal source 22 by a cable 23 via an interface board 24, and are input to the control circuit 12 mounted on the control board 10.

[0090] Incidentally, all of the liquid crystal display panel 1, the gate circuit board 15, the drain circuit boards 16A, 16B, and the control board 10 are depicted as positioned in approximately one plane in FIG. 1, but in actual practice the control board 10 is made approximately perpendicular to the major surface of the liquid crystal display panel 1 by bending the gate circuit board 15 and the drain circuit boards 16A, 16B.

[0091] This is intended to reduce border areas of the liquid crystal display device. In this specification, the border areas mean area between the contour of an outer frame of the liquid crystal display device and that of its display area. The reduction of the border areas provides an advantage of increasing the display area for a fixed size of the outer frame of the liquid crystal display device.

[0092] Liquid Crystal Display Device Module

[0093] FIG. 2 is an exploded perspective view of an embodiment of a module of the liquid crystal display device in accordance with the present invention.

[0094] The liquid crystal display device of FIG. 2 is roughly divided into a liquid crystal display panel module 400, a backlight unit 300, a resin frame 500, an inner frame 700, an upper frame 800 and others which are assembled as a module.

[0095] In this embodiment, a bottom of the resin frame forms a reflective plate which constitutes the backlight unit 300, and therefore it is difficult to distinguish between the backlight unit 300 and the resin frame 500 physically, but it is possible to distinguish between them functionally as explained above.

[0096] Next each of the components will be explained.

[0097] Liquid Crystal Display Panel Module

[0098] The liquid crystal display panel module 400 comprises the liquid crystal display panel 1, the gate driving circuits 5 and the drain driving circuits 6 formed by plural semiconductor ICs and mounted on the periphery of the liquid crystal display panel 1, and the flexible gate circuit board 15 and the flexible drain circuit boards 16A, 16B

connected to input terminals of the gate driving circuit 5 and the drain driving circuits 6, respectively.

[0099] The output signals from the control board 10 explained in detail subsequently are supplied to the gate driving circuits 5 and the drain driving circuit 6 on the liquid crystal display panel 1 via the gate circuit board 15 and the drain circuit boards 16A, 16B, and then the outputs from the gate and drain driving circuits 5, 6 are supplied to the scanning signal lines 3 and the video signal lines 2 of the liquid crystal display panel 1, respectively.

[0100] The display area of the liquid crystal display panel 1 is formed by a large number of pixels arranged in a matrix fashion, a configuration of one pixel is illustrated in FIG. 3.

[0101] In FIG. 3, formed on the major surface of the matrix substrate 1A are the scanning signal line 3 and a counter-voltage signal line 50 extending in the x direction. A region surrounded by the scanning signal line 3, the counter-voltage signal line 50 and the video signal line 2 extending in the y direction which is explained later forms a pixel area.

[0102] In this embodiment, the counter-voltage signal line 50 is formed to run between the adjacent scanning signal lines 3, and pixel areas are formed on the positive and negative sides of the counter-voltage signal line 50 along the y direction.

[0103] With this arrangement, the number of the counter-voltage signal lines 50 arranged in the y direction was reduced to nearly half of that of the conventional liquid crystal display panel, and therefore the areas having been occupied by the counter-voltage signal lines 50 can be used as the pixel areas and the area of each pixel can be increased.

[0104] In each pixel area, equally spaced are, for example, three counter electrodes 50A integrally formed with the counter-voltage signal line 50 and extending in the y direction. The counter electrodes 50A extend to the vicinities of the scanning signal line 3, but are not connected to the scanning signal line 3. The outer two ones of the counter electrodes 50A are disposed adjacently to the video signal lines 2, respectively, and the other one of the counter electrodes 50A is disposed in the center of the pixel area.

[0105] The major surface of the transparent substrate 1A having thereon the scanning signal lines 3, the counter-voltage signal lines 50 and the counter electrodes 50A is covered with an insulating film made of silicon nitride, for example, also covering the scanning signal lines 3, the counter-voltage signal lines 50 and the counter electrodes 50A. The insulating film serves as an interlayer insulating film to insulate the video signal lines 2 explained later from the scanning signal lines 3 and the counter-voltage signal lines 50 and also serves as a gate insulating film for a thin film transistor TFT and as a dielectric film for a storage capacity cstg.

[0106] First, a semiconductor layer 51 is formed in an area of the surface of the insulating film intended for the thin film transistor TFT. The semiconductor layer 51 is made of amorphous Si, for example, and is overlaid on a portion of the scanning signal line 3 close to the video signal line 2 described later such that a portion of the scanning signal line 3 serves as a gate electrode of the thin film transistor TFT also.

[0107] Formed on the surface of the insulating film are the plural video signal lines **2** extending in the y direction and arranged in the x direction. The video signal lines **2** are provided with drain electrodes **2A** formed integrally with the video signal lines **2** and extending to a portion of the surface of the semiconductor layer **51** of the thin film transistor TFT.

[0108] Further, formed on a surface of the insulating film in the pixel area is a pixel electrode **53** connected to a source electrode **53A** of the thin film transistor TFT. The pixel electrode **53** is formed to extend in the middle of the spacing between the adjacent counter-electrodes **50A** in the y direction. One end of the pixel electrode **53A** serves as a source electrode **53A** of the thin film transistor TFT, the pixel electrode **53A** extends in the y direction from its one end, then extends in the x direction on the counter-voltage signal line **50**, and next extends in the y direction such that the pixel electrodes is generally U-shaped.

[0109] A portion of the pixel electrode **53** overlapping the counter-voltage signal line **50** forms a storage capacitance Cstg between the pixel electrode **53** and the counter-voltage signal line **50** using the insulating film as a dielectric film. The storage capacitance provides an effect of storing video information in the pixel electrode **53** for a longer period of time after the thin film transistor TFT is turned off, for example.

[0110] The surfaces of the semiconductor film **51** corresponding to interfaces between the film **51** and the drain electrode **2A** and between the film **51** and the source electrode **53A** of the thin film transistor TFT are doped with phosphorus (P) to form heavily doped layers and thereby to provide ohmic contacts at the drain and source electrodes **2A**, **53A**. In this case, first the heavily doped layer is formed over the entire area of the surface of the semiconductor layer **51**, then the drain and source electrodes **2A**, **53A** are formed, and then the heavily doped layer in the areas other than the areas corresponding to the electrodes **2A**, **53A** are etched away by using the electrodes **2A**, **53A** as masks.

[0111] The upper surface of the insulating film having thereon the thin film transistors TFT, the video signal lines **2**, the pixel electrodes **53** and the storage capacitance Cstg is coated with a protective film made of silicon nitride, for example, and then an orientation film is formed on the protective film to form the so-called lower substrate of the liquid crystal display panel **1**.

[0112] Although not shown in **FIG. 3**, formed on the surface on the liquid crystal layer side of a transparent substrate (a color filter substrate) **1B** intended for the upper substrate is a black matrix **54** (an opening of which is indicated by broken lines in **FIG. 3**) having openings each corresponding to a pixel area.

[0113] Color filters are formed to cover the openings in the black matrix **54** made to correspond to the pixel areas. Color filters are arranged such that colors of filters associated with pixels adjacent to each other in the x direction are different from each other and the boundaries between the adjacent filters are positioned on the black matrix **54**.

[0114] A planarizing film made of resin or the like, for example, is formed on the surface of the substrate **1B** having formed thereon the black matrix **54** and the color filters, and then an orientation film is formed on the planarizing film.

[0115] Backlight

[0116] Returning to **FIG. 2**, a backlight unit **300** is disposed behind the liquid crystal display panel module **400**. This backlight unit **300** is of the so-called downlight type, and as shown in detail in **FIG. 4**, the backlight unit **300** comprises a plurality (eight in **FIG. 4**) of line light sources **35** extending in the x direction and arranged at equal intervals in the y direction in **FIG. 4** and a reflective plate **36** for reflecting light from the line light sources **35** toward the liquid crystal display panel module **400**.

[0117] The reflective plate **36** is shaped to be wavy in the direction (the y direction) of the arrangement of the light sources **35**. The reflective plate **36** is provided with recesses of the arc-shaped cross-section at positions for disposing the respective light sources **35** and slightly sharp projections disposed between adjacent light sources **35**, and this configuration is efficient for directing all the light from the respective light sources **35** toward the liquid crystal display panel module.

[0118] The reflective plate **36** is provided with sidepieces **37** at its sides perpendicular to a direction of the length of the light sources **35**, and both ends of the respective light sources **35** are fitted in slits **38** formed in the sidepieces **37** for preventing movement of the light sources **35** in the direction of the arrangement of the light sources **35**.

[0119] Each of the light sources **35** is provided with two electrodes **35c** and four electrodes **35d** which are mounted around discharge tubes **35a**, for example. The electrodes **35c** and **35d** are disposed at specified intervals in a direction of the axis of the respective discharge tubes **35a**.

[0120] Each of the electrodes **35c** and **35d** is a ring made of aluminum foil into which the discharge tube **35a** is inserted.

[0121] In this embodiment, means for fixing the electrodes around the discharge tube **35a** is not employed, therefore positions of the respective electrodes can be adjusted somewhat relative to the discharge tube **35a** in the direction of the axis of the discharge tube **35a**, and the advantages of this configuration will be explained in detail subsequently.

[0122] Electrodes of the light sources **35** corresponding to each other in position in the direction of the axes of the discharge tubes are connected together by conductive wires, and they are grounded or supplied with a voltage. In other words, all the light sources are connected in parallel with each other and are supplied with voltages.

[0123] **FIG. 5** is a detailed perspective view of one light source **35**. In **FIG. 5**, ground-side electrodes **35d(1)**, **35d(2)**, **35d(3)** and **35d(4)** are disposed at approximately the center and both ends of the discharge tube **35a**, and high-voltage side electrodes **35c(1)** and **35c(2)** are disposed between the ground-side electrodes.

[0124] The ground-side electrodes **35d(2)** and **35d(3)** disposed at the center of the discharge tube **35a** are two separate electrodes, they are connected to those corresponding to each other in position via conductive wires, respectively, as shown in **FIG. 4**, and then the conductive wires connected to the ground-side electrodes **35d(2)** and **35d(3)**, respectively, are connected together and grounded.

[0125] **FIG. 6A** is a cross-sectional view of the discharge tube **35a** having no electrodes within the tube, and **FIG. 6B**

is a cross-sectional view of the discharge tube **35a** taken along line VIB-VIB of **FIG. 6A**. A phosphor **35q** is coated on the inner wall of a glass cylinder tube **35p** (for example, a glass tube of 2.6 mm in outside diameter, 2.0 mm in inside diameter and 390 mm in length) with both ends thereof closed, and a mixture of Ne and 5% of Ar is contained at a pressure of 60 Torr in the glass tube with Hg.

[0126] In the light source **35** of this configuration as shown in **FIG. 5**, application of a high-frequency sinusoidal voltage of several MHz (not lower than 1 MHz) and about 800 Vp-p, for example, to the high-voltage side electrodes **35c(1)**, **35c(2)** creates discharge within the discharge tube **35a** which in turn generates ultraviolet rays, and the ultraviolet rays strike the phosphor **35q** to generate visible light.

[0127] Discharge is created between the ground-side electrode **35d(1)** and the high-voltage side electrode **35c(1)**, between the high-voltage side electrode **35c(1)** and the ground-side electrode **35d(2)**, between the ground-side electrode **35d(3)** and the high-voltage side electrode **35c(2)**, and between the high-voltage side electrode **35c(2)** and the ground-side electrode **35d(4)**, of the discharge tube **35a**.

[0128] In this embodiment, disposed at both the ends of the discharge tube **35a** are the ground-side electrodes **35d(1)**, **35d(4)**, but not the high-voltage side electrodes, and this arrangement improves efficiency of creation of discharge. The reason is that, if the high-voltage side electrodes are disposed at both the ends of the discharge tube **35a**, only high frequency electric fields generated in a space between the high-voltage side electrode and the adjacent ground-side electrode contributes to creation of discharge, but high frequency electric fields generated in a space on the side of the high-voltage side electrode opposite from the adjacent ground-side electrode are not utilized. Arrangement of a pair of the ground-side electrodes **35d(1)** and **35d(2)** and a pair of the ground-side electrodes **35d(3)** and **35d(4)** on opposite sides of the high-voltage side electrodes **35c(1)** and **35c(2)**, respectively, can avoid waste of energy, and therefore the ground-side electrodes **35d(1)** and **35d(2)** are necessarily arranged at both the ends of the discharge tube **35a**, respectively.

[0129] As describe above, the ground-side electrode at disposed at the center of the discharge tube **35a** comprises the two electrically separated electrodes **35d(2)** and **35d(3)**. The reason is that, if the ground-side electrode is formed by one electrically unitary electrode, one discharge between the unitary ground-side electrode and one of the two adjacent high-voltage side electrodes **35c(1)**, **35c(2)** becomes stronger than another discharge between the unitary ground-side and the other of the two adjacent high-voltage side electrodes **35c(1)**, **35c(2)**.

[0130] A ground-side electrode to be disposed between two high-voltage side electrode is divided into two ground-side electrodes so as to form two pairs each comprising one of the two ground-side electrodes and one of the high-voltage side electrodes and thereby to produce uniform discharge.

[0131] **FIGS. 7A-7C** are graphs each showing a luminance distribution of the light source **35** of this configuration along its axis. Here the light source **35** is 390 mm long and the electrodes are arranged as shown in **FIG. 5**. **FIGS. 7A**, **7B** and **7C** show luminance distributions of supply voltages

of a sinusoidal wave of 800 Vp-p, 900 Vp-p and 1000 Vp-p, respectively. As is apparent from these graphs, the luminance distributions are approximately uniform except in the vicinities of the electrodes.

[0132] **FIG. 8A** is a plan view of the backlight unit **300** of **FIG. 2** viewed from its liquid crystal display unit **400** side, and **FIG. 8B** is a cross-sectional view of the backlight unit **300** taken along line VIII-B-VIII-B of **FIG. 8A**.

[0133] At least in an area of the backlight unit **300** facing the liquid crystal display unit **400**, eight light sources **35** extending linearly in the x direction are arranged in the y direction at equal intervals, light from the light sources **35** is directly projected or reflected by the reflective plate **36** toward the liquid crystal display unit **400** such that the backlight unit **300** serves as a planar light source.

[0134] Here there is a concern that non-uniformity in luminance may be produced in regions between the adjacent light sources **35** and in regions corresponding to the electrodes mounted around the light sources **35**, but this concern is sufficiently eliminated by a diffusing plate **60** interposed between the backlight unit **300** and the liquid crystal display unit **400**. Here the diffusing plate **60** can be replaced by any other means for making uniform the illumination on the liquid crystal display panel **1** by the backlight unit **300**.

[0135] **FIG. 9** is a graph showing a relationship between the average luminance and frequencies of the power source when the diffusing plate **60** is employed in the cases shown in **FIGS. 7A-7C**. As is apparent from this graph, the average luminances increase with increasing frequencies.

[0136] In the backlight unit **300** of the above configuration, the electrodes of the light sources **35** are disposed in the vicinities of the outside of the discharge tube, and consequently, no consumption of mercury within the discharge tube due to the electrodes occurs. As a result the lifetime of the light source **35** is lengthened and therefore the lifetime of the liquid crystal display device can be lengthened.

[0137] As described above, the ground-side electrodes **35d** and the high-voltage side electrodes **35c** of the light sources **35** are capable of being moved along the axis of the discharge tube **35a**, and consequently, adjustment by moving the electrodes somewhat can be made such that luminances can be made uniform between the high-voltage side electrodes **35c** and the ground-side electrodes **35d** of the light sources **35**, and therefore this provides the backlight unit **300** having a uniformly illuminated area.

[0138] Resin Frame

[0139] In **FIGS. 8A** and **8B**, the resin frame **500** constitutes a portion of an outer frame of the liquid crystal display device assembled as a module, and houses the backlight unit **300** therein. The resin frame **500** is of the shape of a box having a bottom and four sides, and the top ends of the four sides of the resin frame **500** is configured to mount thereon the diffusing plate **60** which covers the backlight unit **300** (see **FIG. 8B**).

[0140] The diffusing plate **60** has a function of diffusing light from the light sources **35** of the backlight unit **300**, and thereby projects light uniform in luminance toward the liquid crystal display panel module **400**.

[0141] The resin frame **500** is made of relatively thin material, and reduction of its mechanical strength due to its

small thickness is reinforced by the inner frame 700 (see FIG. 2) described subsequently. The rear surface of the resin frame 500 is adapted to have attached thereto a high-frequency power source board 40 (an AC/AC inverter board, for example) (see FIG. 2) for supplying a high frequency voltage to the light source 35.

[0142] The high-frequency power source board 40 is connected to the high-voltage side electrodes 35c and the ground-side electrodes 35d of the light sources 35.

[0143] FIG. 10 is a perspective view of the rear of the resin frame 500, that is, a view of the resin frame 500 as viewed from its side opposite from its side housing the backlight unit 300 therein.

[0144] As is apparent from FIG. 10, the resin frame 500 is formed with one or two raised portions 500A extending in the x direction at sides of the resin frame 500 in the x direction in FIG. 10. The resin frame 500 is formed with sidewalls 500B extending toward its rear surface at sides of its outside in the x direction as viewed from its observer's side. The reason is that the sufficient strength of the box-shaped container formed by a combination of the resin frame 500 and the inner frame 700 (described subsequently) is ensured, in addition to the effect of ensuring the strength against twisting of the resin frame 500 about its diagonal.

[0145] The height of the raised portions 500A is made greater than that of the high-frequency power source board 40, resulting in a relatively larger size, as is apparent from the subsequent explanation. The control board 10 is disposed closely to the sidewalls 500B to face it with the inner frame 700 interposed therebetween as described above. Consequently, this configuration permits the area of the control board 10 having a complicated circuit configuration to be large enough. The inner frame 700 disposed between the control board 10 and the liquid crystal display panel module 400 provides an advantage of functioning as a shield against electromagnetic waves from the control board 10.

[0146] In this embodiment, the raised portions 500A are disposed at the respective sides of the resin frame 500 in the x direction, but it is needless to say that the raised portions 500A can be disposed at the sides of the resin frame 500 in the y direction to obtain the similar advantages.

[0147] High-Frequency Power Source Board

[0148] FIG. 11 is a plan view of the high-frequency power source board 40 disposed on the rear of the resin frame 500.

[0149] Mounted on the high-frequency power source board 40 are transformers 71 corresponding to the respective light sources 35 (eight in number in this embodiment) of the backlight unit 300. But the number of the transformers 71 does not always need to correspond to that of the light sources 35. It is needless to say that one transformer can be provided for each of groups each consisting of two, four, or eight of the light sources 35.

[0150] The high-frequency power source board 40 is disposed on the resin frame 500 via a shield plate 72 made of metal and attached to the rear of the resin frame 500. The shield plate 72 is formed with an opening 72A in a portion thereof approximately corresponding to a mounting position of the high-frequency power source board 40 so as to prevent eddy currents from being produced in the shield plate 72 by the transformers 71. A wiring layer is formed on

the high-frequency power source board 40 and the wiring layer itself has a shielding function.

[0151] The height of the thus mounted high-frequency power source board 40 (the DC/AC inverter board) is such that the power source board 40 including parts mounted thereon does not project beyond the raised portions 500A of the resin frame 500 (see FIG. 10). In other words, the height of the raised portions 500A of the resin frame 500 is set to be so sufficient that the power source board 40 including parts mounted thereon does not project beyond the raised portions 500A.

[0152] Inner Frame

[0153] As shown in FIG. 2, the inner frame 700 is interposed between the liquid crystal display panel module 400 and the diffusing plate (not shown). The inner frame 700 is made of a metal plate of a relatively small thickness and is formed with an opening 42 in area thereof corresponding to the display area of the liquid crystal display panel module 400. The inner frame 700 serves to press the diffusing plate 60 (see FIG. 8B) against the resin frame 500 and to mount thereon the liquid crystal display panel module 400.

[0154] The upper surface of the inner frame 700 on which the liquid crystal display panel module 400 is mounted is provided with spacers 44 at portions thereof for positioning the liquid crystal display panel 1, and thereby the liquid crystal display panel 1 is accurately positioned with respect to the inner frame 700.

[0155] The inner frame 700 has sidewalls 46 integrally fabricated therewith, that is, is generally box-shaped and is formed with the opening 42 in the bottom of the box-shaped metal.

[0156] The inner frame 700 of this shape fits outside the resin frame 500 with the diffusing plate 60 interposed therebetween, that is, the inner surfaces of the sidewalls 46 of the inner frame 700 face the outer surfaces of the sidewalls 500B of the resin frame 500.

[0157] The inner frame 700 made of a metal plate forms one frame (one box-shaped frame) in cooperation with the resin frame 500, and consequently, it is capable of improving the mechanical strength of the resin frame 500 without increasing its thickness. Even if the mechanical strength of each of the inner frame 700 and the resin frame 500 is not sufficient, the mechanical strength of a combination of the two is improved by fitting one of the two into the other is improved, especially the strength against the twisting about the diagonal of the box shape is increased. The raised portions 500A in the resin frame 500 increase the strength against the twisting about the diagonal of the box shape. Consequently, the sufficient mechanical strength of the liquid crystal display panel module is ensured without increasing the border areas around its display area. The inner frame 700 of the above configuration itself is made stronger in mechanical strength than an approximately planar inner frame having no sidewalls, and therefore it facilitates handling of the inner frame 700 in earlier stages of assembling the liquid crystal display panel module.

[0158] In this embodiment, the control board 10 and a DC/DC inverter board 11 are arranged side by side on one of the sidewalls 46 of the inner frame 700, that is, they are disposed in a plane perpendicular to the major surface of the

liquid crystal display panel module **400**, thereby reducing the border areas of the liquid crystal display panel module **400**.

[0159] As shown in **FIG. 1**, the control board **10** is connected to the flexible gate circuit board **15** and the drain circuit boards **16A, 16B** attached to the liquid crystal display panel module **400** via the connecting parts **18, 19A** and **19B**, respectively, and the above arrangement is obtained by bending the gate circuit board **15** and the drain circuit boards **16A, 16B**.

[0160] As described, this arrangement prevents electromagnetic waves generated by the control board **10** from influencing the other components by means of the sidewalls **46** of the inner frame **700**.

[0161] In the above embodiment, the inner frame **700** is explained as box-shaped, but it does not need to be of the shape of the complete box, and it is also sufficient that the inner frame **700** is provided with a sidewall at least one of its four sides. The inner frame of this structure is not planar, but is provided with a bent portion, which improves its mechanical strength.

[0162] Upper Frame

[0163] In **FIG. 2**, the upper frame **800** serves to press the liquid crystal display panel module **400**, the inner frame **700** and the diffusing plate **60** (see **FIG. 8B**) against the resin frame **500**, and also to form an outer frame of the liquid crystal display panel module **400** in cooperation with the resin frame **500**.

[0164] The upper frame **800** is made of a metal plate, is generally box-shaped and formed with an opening (a display window) **48** corresponding to the display area of the liquid crystal display panel module **400**. The upper frame **800** is fixed to the resin frame **500** by clamping the upper frame **800** to the resin frame **500**, for example. The upper frame **800** also serves as a shielding member.

[0165] Assembly

[0166] **FIGS. 12A-12E** illustrates an assembly comprised of the components shown in **FIG. 2**, **FIG. 12A** is a plan view of the assembly as viewed from the upper frame **800** side, **FIGS. 12B and 12C** are side views of the assembly as viewed from the top and bottom sides of **FIG. 12A**, respectively, and **FIGS. 12D and 12E** are side views of the assembly as viewed from the left and right sides of **FIG. 12A**.

[0167] As is apparent from **FIGS. 12D and 12E**, the high-frequency power source board **40** is disposed on the rear of the resin frame **500** not to project beyond the sides of the upper frame **800**, that is, the high-frequency power source board **40** is not observable from the upper frame **800** side.

[0168] As is apparent from **FIGS. 12D and 12E**, the resin frame **500** is generally C-shaped in cross-section due to the presence of its raised portions **500A**. The resin frame **500** of this configuration has great strength against twisting of the resin frame **500** about its diagonal as described above.

Embodiment 2

[0169] **FIG. 13** is a cross-sectional view of another embodiment of the liquid crystal display device in accor-

dance with the present invention obtained by improving the configuration of Embodiment 1, for example.

[0170] **FIG. 13** is a cross-sectional view of the liquid crystal display device taken along a line in the y direction (a direction perpendicular to a direction of the length of the light sources **35**), and this embodiment is similar to that shown in **FIG. 8B**.

[0171] This embodiment differs from Embodiment 1 in that a diffusing plate **50** is disposed to cover the backlight unit **300** on the liquid crystal display panel unit **400** side of the backlight unit **300**, and an electromagnetic shield plate **51** is disposed on the liquid crystal display panel unit **400** side of the diffusing plate **50**.

[0172] The electromagnetic shield plate **51** serves to shield electromagnetic waves from the light sources **35** of the backlight unit **300**, and is made of a transparent conductive sheet or a metal mesh, for example. This configuration prevents disturbances caused by the light sources **35** driven by a high-frequency voltage.

[0173] Of course the same advantages can be obtained by forming the reflective plate **36** of the backlight unit **300** with metal and thereby imparting the function of the electromagnetic shield **51** against the light source **35** to the reflective plate **36**.

[0174] In this embodiment, another diffusing plate **52** is disposed on the liquid crystal display panel unit **400** side of the electromagnetic shield **51** to improve uniformity of illumination on the liquid crystal display panel unit **400** by the backlight unit **300** in cooperation with the diffusing plate **50**. The reason is that, as described above, the light sources **35** are provided with plural electrodes spaced in a direction of their length, and do not emit light from their portions at the electrodes, and further there are wires for connecting together positionally corresponding ones of the electrodes of the respective light sources **35**, thereby somewhat deteriorating uniformity of illumination.

[0175] In **FIG. 13**, the light source **35** is completely shielded by fabricating the frame **500** with metal and disposing the electromagnetic shield **51** to be in direct contact with the frame **500**. The same advantages can be obtained by fabricating the reflective sheet **36** with metal and disposing the electromagnetic shield **51** to be in direct contact with the reflective sheet **36**.

Embodiment 3

[0176] **FIGS. 14A-14C1** are illustrations of modifications of the light sources **35** in the above embodiments.

[0177] **FIG. 14A** illustrates the light source **35** similar to the light sources **35** used in the above embodiments. The electrodes **35c** and **35d** are ring-shaped, and the discharge tube **35** is inserted into the electrodes **35c** and **35d**. **FIG. 14A1** is a cross-sectional view of the light source **35** taken along line XIVA1-XIVA1 of **FIG. 14A**.

[0178] On the other hand, in **FIG. 14B**, the electrodes **35c, 35d** are fabricated to surround partially around the circumference of the discharge tube **35a**. This configuration of the electrodes **35c, 35d** also makes the light source **35** function properly. **FIG. 14B1** is a cross-sectional view of the light source **35** taken along line XIVB1-XIVB1 of **FIG. 14B**.

[0179] In FIG. 14C, the electrodes 35c, 35d are ring-shaped as in the case of FIG. 14A, but a large spacing is provided between the respective electrodes 35c, 35d and the discharge tube 35a. This configuration of the electrodes 35c, 35d also makes the light source 35 function properly. FIG. 14C1 is a cross-sectional view of the light source 35 taken along line XIVC1-XIVC1 of FIG. 14C.

Embodiment 4

[0180] FIGS. 15A-15D and FIGS. 16A-16D are illustrations of modifications of the arrangement of the electrodes 35c, 35d of the light sources 35 in the above embodiments.

[0181] In FIG. 15A, the ground-side electrode 35d and the high-voltage side electrode 35c are at one end and at the other end of the discharge tube 35a, respectively. Although the discharge tube 35a is limited somewhat in length, an increase in a supply voltage can make the light source 35 function sufficiently.

[0182] In FIG. 15B, the high-voltage side electrode 35c is disposed at the center of the discharge tube 35a, and the ground-side electrodes 35d are disposed at both ends of the discharge tube 35a.

[0183] In FIG. 15C, the ground-side electrodes 35d are disposed at the center and both ends of the discharge tube 35a, and the two high-voltage side electrodes 35c are disposed between the ground-side electrodes 35d, respectively.

[0184] In FIG. 15D, the ground-side electrode 35d is disposed at the center of the discharge tube 35a, and the high-voltage side electrodes 35c are disposed at both ends of the discharge tube 35c.

[0185] In FIG. 16A, the high-voltage side electrodes 35c are disposed at the center and both ends of the discharge tube 35a, and the ground-side electrodes 35d are disposed between the high-voltage side electrodes 35c.

[0186] In FIG. 16B, the ground-side electrodes 35d are disposed at the center and both ends of the discharge tube 35a, and the high-voltage side electrodes 35c are disposed between the ground-side electrodes 35d. The ground-side electrode at the center of the discharge tube 35a is divided into two ground-side electrodes 35d, and this arrangement is the same as that shown in FIG. 5.

[0187] In FIG. 16C, the ground-side electrode is disposed at the center of the discharge tube 35a, and the high-voltage side electrodes 35c are disposed at both ends of the discharge tube 35a. The ground-side electrode at the center of the discharge tube 35a is divided into two ground-side electrodes 35d.

[0188] In FIG. 16D, the high-voltage side electrodes 35c are disposed at the center and both ends of the discharge tube 35a, and the ground-side electrodes are disposed between the high-voltage side electrodes 35c. The ground-side electrodes are divided into two ground-side electrodes 35d.

[0189] As is apparent from the above modifications, at least one pair of a ground-side electrode 35d and a high-voltage side electrode 35c is provided, the discharge tube 35a between these electrodes creates a sufficient discharge and thereby functions as the light source 35.

[0190] The optimum number of the electrodes to be arranged can be selected depending upon the length of the discharge tube or the supply voltage from the power source.

Embodiment 5

[0191] FIGS. 17A-17C are illustrations of other embodiments of the ground-side electrodes of the light source 35 in the above embodiments. For example, the embodiments of FIGS. 17A, 17B and 17C are similar to those shown in FIGS. 15A, 15B and 16B, respectively.

[0192] Each of the ground-side electrodes 35d disposed at ends of the discharge tube 35a in FIGS. 17A-17C is provided with an auxiliary electrode 70 disposed on its side facing the high-voltage side electrode 35c. The width of the auxiliary electrodes 70 is smaller than that of the ground-side electrode 35d.

[0193] Consider a case in which the auxiliary electrode 70 is not present. Then luminance generated by a discharge between the ground-side electrode 35d and the high-voltage side electrode 35c is sometimes graded along the axis of the discharge tube 35a. It was confirmed that provision of the auxiliary electrode 70 made uniform the luminance between the ground-side electrode 35d and the high-voltage side electrode 35c.

[0194] In FIGS. 17A-17C, one auxiliary electrode 70 is provided to one ground-side electrodes 35d, but it is needless to say that two or more auxiliary electrodes can be provided to one ground-side electrode 35d. The auxiliary electrodes 70 can be configured such that their positions can be finely adjusted with respect to their adjacent ground-side electrodes 35d along the axis of the discharge tube 35a so as to improve uniformity of discharge.

Embodiment 6

[0195] FIG. 18 illustrates another embodiment of the liquid crystal display device in accordance with the present invention, and this embodiment is similar to that shown in FIG. 4.

[0196] A difference in configuration between FIG. 18 and FIG. 4 is in the discharge tube 35a. The discharge tube 35a is of the shape of a single continuous folded line which comprises plural linear tubular portions and plural bend portions for connecting ends of adjacent ones of the plural linear tubular portions, and forms a planar area light source facing the display area of the liquid crystal display panel.

[0197] Although the bend portions are present in the discharge tube 35a, the folded-line discharge tube 35a provides an advantage of facilitating its fabrication and assembling if the number of the bend portions is small.

[0198] For the same purpose, for example, as shown in FIG. 19, the light source 35 can be made up of plural (four in FIG. 9) folded-line discharge tubes 35a arranged side by side to form a planar area light source. In this example also, the above-described structure and arrangement of the electrodes 35c, 35d are equally applicable.

[0199] In the above embodiments, no special restrictions are imposed on the frequency of the high-frequency voltage supplied to the high-voltage side electrodes 35c. The following embodiments are configurations advantageous in cases where the frequency of the high-frequency voltage is

equal to or higher than 1 MHz. But in the following embodiments, the frequency of the high-frequency voltage supplied to the high-voltage side electrodes 35c does not need to be equal to or higher than 1 MHz.

[0200] When the frequency of the high-frequency voltage supplied to the high-voltage side electrode 35c is equal to or higher than 1 MHz, as shown in an equivalent circuit of FIG. 20B for a configuration of FIG. 20A, for example, voltage drops due to capacitances Cd formed by the glass and the phosphor of the discharge tube 35a are reduced, and consequently, the supply voltage can be effectively applied across the light-generating portion of the discharge tube 35a.

[0201] The high-frequency voltage of a frequency equal to or higher than 1 MHz can raise the electron temperature of the light-generating portion. As shown in FIG. 21, within the discharge tube 35a, positive ions can hardly follow the high-frequency electric fields because of their greater mass, and therefore the energy of the electric fields can be efficiently converted into the kinetic energy of electrons e. Consequently, the average kinetic energy of the electrons e increases, the probability of exciting mercury within the discharge tube 35a, and thereby the luminance of the discharge tube 35a is improved.

[0202] It is known that it is necessary to ensure a specified density of charged particles in the discharge space so as to maintain the discharge within the discharge tube 35a. If the discharge tube 35a is driven at a lower frequency, charged particles within the discharge tube 35a are easily consumed by the electrodes, and therefore it is necessary that a portion serving as a cathode emits a large number of secondary electrons. This emission of the secondary electrons requires a large amount of energy, and causes a cathode voltage drop, resulting in deterioration of luminous efficacy.

[0203] In the case of the driving at a frequency equal to or higher than 1 MHz, the charged particles are captured within the discharge tube 35a, and this makes it difficult for the charged particles to reach the portions serving as a cathode and an anode, and reduces the required amount of secondary electrons, thereby reducing the cathode voltage drop, and consequently, low-voltage driving of the discharge tube 35a is realized and the luminous efficacy of the discharge tube 35a is improved.

[0204] In view of the above, it is preferable for the backlight of the liquid crystal display device to select the frequency of the high-frequency voltage for the discharge tube 35a to be at least 1 MHz, because the liquid crystal display devices are required to reduce its power consumption and to improve uniformity of the luminance. However, it was confirmed that, as shown in FIG. 22, lines of electric force from the electrode 35c at one end of the discharge tube 35a do not terminate on the other electrode 35d at the other end of the discharge tube 35a, but leak out at the center of the discharge tube 35a, and consequently, a problem arises in that uniformity in luminance is not ensured.

[0205] The following embodiments are capable of reducing at least the leakage of the lines of electric force and provide an advantage of improving uniformity in luminance.

Embodiment 7

[0206] FIG. 23A is an illustration of another embodiment of the liquid crystal display device in accordance with the

present invention, and this embodiment is similar to that shown in FIG. 5. This embodiment differs from that shown in FIG. 5, in that the ground-side electrodes 35d(2) and 35d(3) at the center of the discharge tube 35a are eliminated, the high-voltage side electrode 35c(1) is supplied with a high-frequency voltage of a frequency f1 from the high-frequency power source PS1, and the other high-voltage side electrode 35c(2) is supplied with a high-frequency voltage of a frequency f2 ($\neq f1$) from the high-frequency power source PS2.

[0207] In this embodiment, for example, the high-frequency voltage from the high-frequency power source PS1 is 860 Vp-p and 5.1 MHz, and the high-frequency voltage from the high-frequency power source PS2 is 700 Vp-p and 5.25 MHz.

[0208] FIG. 23B shows a relationship in waveform between the high-frequency voltages supplied to the high-voltage side electrodes 35c(1) and 35c(2).

[0209] By supplying the two high-frequency voltages having the above waveform relationship to the respective high-voltage side electrodes 35c, a voltage difference between the electrodes is made approximately uniform with passage of time, and the amount of leakage of lines of electric force is reduced. If the two voltages in phase with each other are applied to the respective electrodes, the electric field at the centers of the respective electrodes is reduced, and thereby reduction of luminance at the centers is prevented.

[0210] It was confirmed that the above phenomenon is also applicable in the following embodiments.

[0211] As shown in FIG. 24A, eight discharge tubes 35a, for example, are arranged within the backlight of the liquid crystal display device. Corresponding ones of the electrodes of the discharge tube 35a are connected together to form a parallel combination.

[0212] By considering the following, the discharge tubes 35a can be arranged in the container of the backlight so as to provide luminance uniform along the axis of the discharge tubes 35a.

[0213] Stray capacitances present between the discharge tubes 35a and their neighboring conductors are determined by distance therebetween and the areas of the neighboring conductors, and therefore the discharge tubes 35a need to be arranged symmetrically with respect to the container.

[0214] The discharge tubes 35a need to be arranged so as not to form an extremely large stray capacitance locally in a direction of the axis of the discharge tubes 35a. For example, the discharge tubes 35a need to be arranged such that a neighboring conductor does not approach the discharge tubes 35a extremely closely and locally in the direction of the axis of the discharge tubes 35a.

[0215] As for the arrangement of the discharge tubes 35a in the container of the backlight, the above considerations are also applicable in the following embodiments.

[0216] FIG. 24B is a graph showing a luminance distribution in a direction of the axis of the discharge tube 35a on the surface of the above-explained backlight facing the liquid crystal display panel 1. As is apparent from this graph, the luminance as a whole along the axis of the discharge tube 35a is improved, and in particular, the reduction of lumi-

nance at the center of the light source can be decreased as indicated by an arrow in **FIG. 24B**.

Embodiment 8

[0217] **FIG. 25A** is an illustration of another embodiment of the liquid crystal display device in accordance with the present invention, and this embodiment is similar to that shown in **FIG. 23A**.

[0218] Like the embodiment shown in **FIG. 23A**, the ground-side electrodes **35d(2)**, **35d(3)** are absent at the center of the discharge tube **35a** in this embodiment.

[0219] This embodiment differs from that shown in **FIG. 23A**, in that the high-voltage side electrode **35c(1)** is supplied with a first high-frequency voltage from the high-frequency power source PS, and the other high-voltage side electrode **35c(2)** is supplied with a second high-frequency voltage reversed in phase from the first high-frequency voltage via a toroidal coil TC, for example, from the high-frequency power source PS.

[0220] Here a voltage of 700 Vp-p and 5 MHz, for example, can be used as the first and second high-frequency voltages from the high-frequency power source PS.

[0221] **FIG. 25B** shows a relationship in waveform between the high-frequency voltages supplied to the high-voltage side electrodes **35c(1)** and **35c(2)**.

[0222] As shown in **FIG. 26A**, eight discharge tubes **35a**, for example, are arranged within the backlight of the liquid crystal display device, and they are connected in parallel with each other.

[0223] **FIG. 26B** is a graph showing a luminance distribution in a direction of the axis of the discharge tube **35a** on the surface of the above-explained backlight facing the liquid crystal display panel 1. The luminance at the center of the light source can be greatly improved as indicated by an arrow in **FIG. 26B**.

Embodiment 9

[0224] **FIG. 27A** is an illustration of another embodiment of the liquid crystal display device in accordance with the present invention, and this embodiment is similar to that shown in **FIG. 23A**.

[0225] Like the embodiment shown in **FIG. 23A**, the ground-side electrodes **35d(2)**, **35d(3)** are absent at the center of the discharge tube **35a** in this embodiment.

[0226] This embodiment differs from that shown in **FIG. 23A**, in that the high-voltage side electrode **35c(1)** is supplied with a first high-frequency voltage from the high-frequency power source PS, and the other high-voltage side electrode **35c(2)** is supplied with a second high-frequency voltage out of phase with the first high-frequency voltage via a phase-adjusting coil PC, for example, from the high-frequency power source PS.

[0227] **FIG. 27B** shows a relationship in waveform between the high-frequency voltages supplied to the high-voltage side electrodes **35c(1)** and **35c(2)**.

[0228] As shown in **FIG. 28**, eight discharge tubes **35a**, for example, are arranged within the backlight of the liquid crystal display device, and they are connected in parallel with each other.

[0229] In a luminance distribution in a direction of the axis of the discharge tube **35a** on the surface of the above-explained backlight facing the liquid crystal display panel 1, the luminance at the center of the discharge tubes **35a** can be greatly improved as in the above embodiments.

Embodiment 10

[0230] **FIG. 29A** is an illustration of another embodiment of the liquid crystal display device in accordance with the present invention.

[0231] In **FIG. 29A**, the discharge tube **35a** is housed within a shield case, and is provided with the high-voltage side electrodes **35c(1)**, **35c(2)** at both ends of the discharge tube **35a**, respectively. The high-voltage side electrode **35c(1)** is supplied with a high-frequency voltage of a frequency f_1 from the high-frequency power source PS1, the other high-voltage side electrode **35c(2)** is supplied with a high-frequency voltage of a frequency f_2 from the high-frequency power source PS2, and the shield case is grounded. Housing of the discharge tube **35a** within the grounded shield case makes the driving circuit a closed circuit using stray capacitances between the shield case and the discharge tube **35a**, and therefore this eliminates the need for providing the discharge tube **35a** itself with the ground-side electrode **35d**.

[0232] This configuration eliminates reduction in luminance which would otherwise be caused in the vicinities of the ground-side electrode **35d**, and consequently, it flattens a luminance distribution in a direction of the axis of the discharge tube **35a**.

[0233] It is ideal that the shield case is formed so as to surround the discharge tube **35a** completely, but no problems arise if the shield case is formed with an opening at a portion corresponding to the display area of the liquid crystal display panel. For example, the same advantages are obtained by fabricating the reflective plate **36** shown in **FIG. 13** using a conductive plate, forming a shield case by electrically connecting the reflective plate **36** to the inner frame **800** made of conductive material, and then grounding the shield case.

[0234] The above configurations of the shield case are also applicable for grounding in the following embodiments.

[0235] **FIG. 29B** shows a relationship in waveform between the high-frequency voltages supplied to the high-voltage side electrodes **35c(1)** and **35c(2)**.

[0236] As shown in **FIG. 30**, eight discharge tubes **35a**, for example, are arranged within the backlight of the liquid crystal display device, and they are connected in parallel with each other.

Embodiment 11

[0237] **FIG. 31A** is an illustration of another embodiment of the liquid crystal display device in accordance with the present invention, and this embodiment is similar to that shown in **FIG. 29A**.

[0238] In **FIG. 31A**, the discharge tube **35a** is housed within a shield case, and is provided with the high-voltage side electrodes **35c(1)**, **35c(2)** at both ends of the discharge tube **35a**, respectively. The high-voltage side electrode **35c(1)** is supplied with a first high-frequency voltage from

the high-frequency power source PS, the other high-voltage side electrode **35c(2)** is supplied with a second high-frequency voltage reversed in phase from the first high-frequency voltage via a toroidal coil TC from the high-frequency power source PS, and the shield case is grounded. As in the embodiment shown in **FIG. 29A**, housing of the discharge tube **35a** within the grounded shield case makes the driving circuit a closed circuit using stray capacitances between the shield case and the discharge tube **35a**, and therefore this eliminates the need for providing the discharge tube **35a** itself with the ground-side electrode **35d**.

[0239] **FIG. 31B** shows a relationship in waveform between the high-frequency voltages supplied to the high-voltage side electrodes **35c(1)** and **35c(2)**.

[0240] As shown in **FIG. 32A**, eight discharge tubes **35a**, for example, are arranged within the backlight of the liquid crystal display device, and they are connected in parallel with each other.

[0241] **FIG. 32B** is a graph showing a luminance distribution in a direction of the axis of the discharge tube **35a** on the surface of the above-explained backlight facing the liquid crystal display panel. As is apparent from this graph, a luminance distribution along the axis of the discharge tube **35a** is made uniform, and the luminance at the center of the discharge tube **35a** can be greatly improved.

[0242] In this embodiment, the circuit configuration shown in **FIG. 31A** is utilized for supplying the two voltages opposite in phase from each other to the two high-voltage side electrodes **35c(1)**, **35c(2)**, respectively, but the present invention is not limited to this circuit configuration. The circuit configurations shown in **FIGS. 31C-31F**, for example, can be utilized instead of the circuit configuration shown in **FIG. 31A**. Especially, the circuit configurations shown in **FIGS. 31D-31F** use two high-frequency power sources, and thereby they can apply higher voltages between the high-voltage side electrodes **35c(1)**, **35c(2)**. Utilization of the two high-frequency power sources is not limited to the phase-reversal driving, but is also applicable to the driving by using two-frequency voltages or two-different-phase voltages.

Embodiment 12

[0243] This embodiment is directed to improvement of a toroidal coil TC for phase reversal used in Embodiment 12, for example. Usually a toroidal coil TC as shown in **FIG. 45A** can be used as shown in **FIG. 45B**, but when the toroidal coil is used at a frequency above 5 MHz, the phase-reversal driving sometimes failed to operate perfectly or the surface temperature of the toroidal coil sometimes rose to 60° C., resulting in excessive power loss.

[0244] These problems were solved by a toroidal coil shown in **FIG. 46A** which is fabricated by winding two wires twisted together around a toroidal core, and this toroidal coil is used as shown in **FIG. 6B**. As an example, when a toroidal coil was fabricated by winding 27 turns uniformly along the complete circumference of the toroidal core, the surface temperature of the toroidal core during operation was 40° C., which was lower by 20° C. than that of the toroidal coil TC shown in **FIG. 45A**. The possible frequency of the phase-reversal driving was increased to 17 MHz.

Embodiment 13

[0245] **FIG. 33A** is an illustration of another embodiment of the liquid crystal display device in accordance with the present invention, and this embodiment is similar to that shown in **FIG. 29A**.

[0246] In **FIG. 33A**, the discharge tube **35a** is housed within a shield case. The high-voltage side electrode **35c(1)** disposed at one end of the discharge tube **35a** is supplied with a first high-frequency voltage from the high-frequency power source PS, the high-voltage side electrode **35c(2)** disposed at the other end of the discharge tube **35a** is supplied with a second high-frequency voltage out of phase with the first high-frequency voltage via a phase-adjusting coil PC, for example, from the high-frequency power source PS, and the shield case is grounded. In the embodiment also, housing of the discharge tube **35a** within the grounded shield case makes the driving circuit a closed circuit using stray capacitances between the shield case and the discharge tube **35a**, and therefore this eliminates the need for providing the discharge tube **35a** itself with the ground-side electrode.

[0247] **FIG. 33B** shows a relationship in waveform between the high-frequency voltages supplied to the high-voltage side electrodes **35c(1)** and **35c(2)**.

[0248] As shown in **FIG. 34**, eight discharge tubes **35a**, for example, are arranged within the backlight of the liquid crystal display device, and they are connected in parallel with each other.

Embodiment 14

[0249] **FIG. 35A** is an illustration of another embodiment of the liquid crystal display device in accordance with the present invention, and this embodiment is similar to that shown in **FIG. 33A**.

[0250] In **FIG. 35A**, the discharge tube **35a** is housed within a shield case, and is provided with the high-voltage side electrodes **35c(1)**, **35c(3)**, **35c(2)** at both ends and the center of the discharge tube **35a**, respectively. The high-voltage side electrodes **35c(1)**, **35c(3)** at both the ends are supplied with a high-frequency voltage of a frequency f_1 from the high-frequency power source PS1, the high-voltage side electrode **35c(2)** at the center is supplied with a high-frequency voltage of a frequency f_2 ($=f_1$) from the high-frequency power source PS2, and the shield case is grounded. Even when the discharge tube **35a** is provided with three or more electrodes, all the electrodes are used as the high-voltage side electrodes, and no ground-side electrodes are provided so as to prevent reduction in luminance which would otherwise be caused in the vicinities of the ground-side electrodes.

[0251] **FIG. 35B** shows a relationship in waveform between the high-frequency voltage supplied to the high-voltage side electrodes **35c(1)**, **35c(3)** and the high-frequency voltage supplied to the high-voltage side electrode **35c(2)**.

[0252] As shown in **FIG. 36**, eight discharge tubes **35a**, for example, are arranged within the backlight of the liquid crystal display device, and they are connected in parallel with each other.

Embodiment 15

[0253] FIG. 37A is an illustration of another embodiment of the liquid crystal display device in accordance with the present invention, and this embodiment is similar to that shown in FIG. 35A.

[0254] In FIG. 37A, the discharge tube 35a is housed within a shield case, and is provided with the high-voltage side electrodes 35c(1), 35c(3), 35c(2) at both ends and the center of the discharge tube 35a, respectively. The high-voltage side electrodes 35c(1), 35c(3) at both the ends are supplied with a first high-frequency voltage from the high-frequency power source PS, the high-voltage side electrode 35c(2) at the center is supplied with a second high-frequency voltage reversed in phase from the first high-frequency voltage via a toroidal coil TC, for example, from the high-frequency power source PS, and the shield case is grounded.

[0255] FIG. 37B shows a relationship in waveform between the high-frequency voltage supplied to the high-voltage side electrodes 35c(1), 35c(3) and the high-frequency voltage supplied to the high-voltage side electrode 35c(2).

[0256] As shown in FIG. 38, eight discharge tubes 35a, for example, are arranged within the backlight of the liquid crystal display device, and they are connected in parallel with each other.

[0257] This embodiment also provides the same advantages as Embodiment 14.

Embodiment 16

[0258] FIG. 39A is an illustration of another embodiment of the liquid crystal display device in accordance with the present invention, and this embodiment is similar to that shown in FIG. 37A.

[0259] In FIG. 39A, the discharge tube 35a is housed within a shield case, and is provided with the high-voltage side electrodes 35c(1), 35c(3), 35c(2) at both ends and the center of the discharge tube 35a, respectively. The high-voltage side electrodes 35c(1), 35c(3) at both the ends are supplied with a first high-frequency voltage from the high-frequency power source PS, the high-voltage side electrode 35c(2) at the center is supplied with a second high-frequency voltage out of phase with the first high-frequency voltage via a phase-adjusting coil PC, for example, from the high-frequency power source PS, and the shield case is grounded.

[0260] FIG. 39B shows a relationship in waveform between the high-frequency voltage supplied to the high-voltage side electrodes 35c(1), 35c(3) and the high-frequency voltage supplied to the high-voltage side electrode 35c(2).

[0261] As shown in FIG. 40, eight discharge tubes 35a, for example, are arranged within the backlight of the liquid crystal display device, and they are connected in parallel with each other.

[0262] This embodiment also provides the same advantages as Embodiment 14.

Embodiment 17

[0263] In ones of the above embodiments in which a pair of the high-voltage side electrodes 35c are supplied with two

high-frequency voltages out of phase with each other, a circuit can be employed for adjusting their phase difference arbitrarily.

[0264] As is apparent from FIGS. 41A-41C, a voltage difference between two high-voltage side electrodes 35c(1), 35c(2) is increased by supplying to one of the high-voltage side electrodes 35c(1), 35c(2) a high-frequency voltage having a large phase difference with respect to another high-frequency voltage supplied to the other of the high-voltage side electrodes 35c(1), 35c(2), and this provides an advantage of making possible optimization of discharge in the discharge tube 35a.

[0265] As explained in Embodiments 13 and 15, in a case in which the discharge tube 35a is provided with three or more high-voltage side electrodes 35c, by provision of a circuit for adjusting arbitrarily a phase of a high-frequency voltage supplied to a respective one of the high-voltage side electrodes 35c (one of the high-voltage side electrodes 35c may be supplied with a high-frequency voltage of a fixed frequency serving as a reference), discharge between adjacent ones of the high-voltage side electrodes 35c in the discharge tube 35a can be established to be in a specified state, and this provides an advantage of making uniform illumination over the entire display area by light from the backlight intended for the planar area light source.

Embodiment 18

[0266] Among the above embodiments, in the embodiments (Embodiments 13, 14 and 15, for example) in which the discharge tube 35a is provided with three or more high-voltage side electrodes 35c, the intervals between adjacent ones of the high-voltage side electrodes 35c are described as equal.

[0267] However, it is needless to say that a distance from a first high-voltage side electrode 35c(1) at one end of the discharge tube 35a to a second high-voltage side electrode 35c(2) between the ends of the discharge tube 35a can be made unequal to a distance from a third high-voltage side electrode 35c(3) to the second high-voltage side electrode 35c(2), as shown in FIG. 42A, for example. The reason is that there are cases where it is preferable not to equalize distances between the electrodes in view of structural limitation of the backlight unit containing the discharge tubes 35a or balancing luminance of the backlight.

[0268] In this embodiment, when there are phase differences made among the high-frequency voltages supplied to the high-voltage side electrodes 35c(1), 35c(2), 35c(3), respectively, as shown in FIG. 42B, uniformity in luminance is improved if the following relationship is satisfied:

[0269] a voltage difference between the high-voltage side electrodes 35c(1), 35c(2) < a voltage difference between the high-voltage side electrodes 35c(2), 35c(3).

[0270] Conversely speaking, when the driving voltages are chosen to satisfy the above relationship, uniformity in luminance is improved by selecting the phase differences among the high-frequency voltages supplied to the high-voltage side electrodes 35c(1), 35c(2), 35c(3), respectively, as shown in FIG. 42B.

Embodiment 19

[0271] FIG. 43A is an illustration of another embodiment of the liquid crystal display device in accordance with the present invention, and this embodiment is similar to that shown in FIG. 35A.

[0272] This embodiment differs from that shown in FIG. 35A, in that the discharge tube 35a is provided with the high-voltage side electrodes 35c(1), 35c(3), 35c(2) at both its ends and its center, respectively, the high-voltage side electrode 35c(1) at one end is supplied with a high-frequency voltage of a frequency f1 from the high-frequency power source PS1, the high-voltage side electrode 35c(2) at the center is supplied with a high-frequency voltage of a frequency f2 (#f1) from the high-frequency power source PS2, and the high-voltage side electrode 35c(3) at the other end is supplied with a high-frequency voltage of a frequency f3 ($\neq f1, f2$) from the high-frequency power source PS3.

[0273] FIG. 43B shows a relationship in waveform among the high-frequency voltages supplied to the high-voltage side electrodes 35c(1), 35c(2) and 35c(3).

[0274] With this configuration, distances between adjacent high-voltage side electrode 35c(1), 35c(2), 35c(3) can be made smaller in the discharge tube 35a and thereby the required driving voltages and the widths of the electrodes can be reduced. Consequently, unlike this embodiment, the number of the high-voltage side electrode is not limited to three, but can be more than three.

Embodiment 20

[0275] FIG. 44A is an illustration of another embodiment of the liquid crystal display device in accordance with the present invention.

[0276] The high-voltage side electrodes 35c(1) at one end of the discharge tube 35a is supplied with a first high-frequency voltage from the high-frequency power source PS1, the high-voltage side electrode 35c(3) at the other end of the discharge tube 35a is supplied with a second high-frequency voltage reversed in phase from the first high-frequency voltage via a toroidal coil TC, for example, from the high-frequency power source PS1, and the high-voltage side electrode 35c(2) at the center of the discharge tube 35a is supplied with a third high-frequency voltage of a frequency different from that of the first and second high-frequency voltages from the high-frequency power source PS2. That is to say, the high-voltage side electrodes at both ends of the discharge tube 35 are supplied with two high-frequency voltages reverse from each other, respectively, and the high-voltage side electrode 35 at the center of the discharge tube is supplied with a high-frequency voltage of a frequency different from that of the high-frequency voltages supplied to the high-voltage side electrodes at both the ends.

[0277] FIG. 44B shows a relationship in waveform among the three high-frequency voltage supplied to the high-voltage side electrodes 35c(1), 35c(2) and 35c(3), respectively.

[0278] As is apparent from a luminance distribution in a direction of the axis of the discharge tube of the above configuration shown in FIG. 44C, an approximately uniform luminance is ensured by this embodiment.

Embodiment 21

[0279] In this embodiment, the conditions for discharge at the two outside opposing electrodes 35c(1), 35c(2) mounted around the discharge tube 35a are equalized and the discharge is made continuous between the two outside opposing electrodes 35c(1), 35c(2), and thereby uniform luminance is obtained along the axis of the discharge tube 35a.

[0280] As shown in FIG. 47, a center tap of a secondary winding of a transformer in an inverter is grounded, and thereby the two outside opposing electrodes 35c(1), 35c(2) are made symmetrical with each other in the electrical circuit configuration. As is apparent from FIG. 47, lines of electric force between the two outside opposing electrodes 35c(1), 35c(2) are uniform and parallel with each other in distribution.

Embodiment 22

[0281] In this embodiment also, the conditions of discharge at the two outside opposing electrodes 35c(1), 35c(2) mounted around the discharge tube 35a are equalized and the discharge is made continuous between the two outside opposing electrodes 35c(1), 35c(2), and thereby uniform luminance is obtained along the axis of the discharge tube 35a.

[0282] As shown in FIG. 48, the lengths and the routings of lamp cables connected to two outside opposing electrodes 35c(1), 35c(2) are made symmetrical. Lines of electric force between the two outside opposing electrodes 35c(1), 35c(2) are made uniform and parallel with each other in distribution.

Embodiment 23

[0283] In this embodiment, neighboring conductors in the vicinities of the discharge tube 35a are made symmetrical with each other to provide an electrical symmetry.

[0284] In FIG. 49, stray capacitances Cs, Cs' present between the discharge tube 35a and its neighboring conductors such as portions of a container are determined by distances d, d' between the discharge tube 35a and its neighboring conductors and areas of the neighboring conductors, and therefore the neighboring conductors are made symmetrical with respect to the center of the discharge tube 35a in a direction of the axis of the discharge tube 35a. This configuration provides lines of electric force uniform and parallel with each other between the two outside opposing electrodes 35c(1), 35c(2) mounted around the discharge tube 35a.

Embodiment 24

[0285] This embodiment obtains electrical uniformity by making uniform the neighboring conductors in the vicinities of the discharge tube 35a.

[0286] In FIG. 50, in order to make uniform the stray capacitances Cs, Cs', Cs'' present between the discharge tube 35a and its neighboring conductors such as portions of a container, the shape of the neighboring conductor facing the discharge tube 35a is made uniform along the axis of the discharge tube 35a such that $d=d'$. With this configuration, the neighboring conductor in the vicinities of the discharge tube 35a is provided with symmetry, and thereby lines of

electric force between the two outside opposing electrodes **35c(1)**, **35c(2)** mounted around the discharge tube **35a** are made parallel with each other and uniform in distribution.

Embodiment 25

[0287] In **FIG. 51**, a voltage for driving the discharge tube **35a** is sufficiently increased such that an impedance between the outside electrodes **35c(1)**, **35c(2)** mounted around the discharge tube **35a** is made sufficiently small compared with an impedance of stray capacitances formed around the discharge tube **35a**.

[0288] **FIG. 51** shows an equivalent circuit of a driving circuit for the discharge tube **35a** including stray capacitances C_s , C_{s2} . The driving voltage is selected so as to equalize the absolute values of two currents flowing into the outside electrodes **35c(1)**, **35c(2)**, respectively, at a time. In other words, the applied voltage is made so large that leakage currents can be neglected and the discharge is made continuous between the the outside electrodes **35c(1)**, **35c(2)**. When the output of the inverter circuit is made sufficiently large, the discharge current of the discharge tube **35a** increases, the charge density in its light-generating region (the plasma) is increased, and consequently, the resistances RL of the discharge tube **35a** are made smaller than the impedance ($1/(2\pi fC_s)$) of a leakage path of leakage currents, where f =a frequency of the driving voltage, and C_s =a stray capacitance. As a result almost all of the currents flow within the discharge tube **35a**.

[0289] When a frequency of the driving voltage is selected to be as high as 1 MHz or more, for example, leakage paths for leakage currents are easily formed, and therefore it is important to reduce the resistances of the light-generating region (the plasma) of the discharge tube **35a** by supplying a sufficiently high voltage to the discharge tube **35a** as described above. For example, the good results are obtained by selecting the driving voltage such that the impedance of the light-generating region is made equal to or less than one tenth of the impedance of the stray capacitances formed around the discharge tube **35a**.

Embodiment 26

[0290] In the above embodiments, the waveforms of the discharge currents of the discharge tube **35a** have been explained as sinusoidal as shown in **FIG. 52A**, but the present invention is not limited to this waveform, and the point is that the waveforms only need to change the flowing directions of the discharge currents periodically. Consequently, the waveforms of the discharge currents in the above embodiments can be rectangular as shown in **FIG. 52B**, or can be in the form of pulses as shown in **FIG. 52C**.

[0291] Starting characteristics of the discharge tube **35a** can be improved by supplying to the discharge tube **35a** at the time of starting it a voltage higher than a required voltage for its normal operation.

[0292] Embodiments 21-26 are equally applicable to the phase-reversal driving, the two-different-phase driving and the two-frequency driving which have been described above.

[0293] The present invention has been explained in detail by using the embodiments, and the representative configurations of the present invention can be summarized as follows:

[0294] As for the driving voltages supplied to the outside electrodes mounted around the outside of the discharge tube, there are

[0295] (1) a driving method of applying driving voltages reversed in phase from each other to adjacent ones of the outside electrodes mounted around the outside of the discharge tube, respectively,

[0296] (2) a driving method of applying driving voltages of frequencies different from each other to adjacent ones of the outside electrodes mounted around the outside of the discharge tube, respectively, and

[0297] (3) a driving method of applying driving voltages out of phase with each other to adjacent ones of the outside electrodes mounted around the outside of the discharge tube, respectively.

[0298] The following are techniques for heightening the beneficial effects of the above three driving methods in combination with each of them:

[0299] (a) selecting the frequency of the driving voltages to be 1 MHz or more;

[0300] (b) using two or more power sources for the driving voltages;

[0301] (c) providing the discharge tube with at least three of the outside electrodes;

[0302] (d) changing the flowing directions of discharge currents between a pair of adjacent ones of the outside electrodes periodically;

[0303] (e) making a pair of adjacent ones of the outside electrodes symmetrical with each other, for example,

[0304] (i) arranging the pair of adjacent ones of the outside electrodes electrically symmetrical with each other,

[0305] (ii) equalizing the lengths of two lamp cables connected to the pair of adjacent ones of the outside electrodes, respectively,

[0306] (iii) making the neighboring conductors in the vicinities of the pair of adjacent ones of the outside electrodes geometrically symmetrical with each other;

[0307] (f) grounding none of the outside electrodes;

[0308] (g) selecting the driving voltages to be sufficiently large such that an impedance between two adjacent ones of the outside electrodes is made sufficiently small compared with an impedance of stray capacitances formed around the discharge tube in the vicinities of the two adjacent ones of the outside electrodes, for example, selecting the driving voltage such that the impedance between the two adjacent ones of the outside electrodes is made equal to or less than one tenth of the impedance of the stray capacitances formed around the discharge tube in the vicinities of the two adjacent ones of the outside electrodes; and

[0309] (h) supplying to the discharge tube at the time of starting it a voltage higher than a required driving voltage for its normal operation to improve its starting characteristics.

[0310] As is apparent from the above explanation, the liquid crystal display device in accordance with the present invention provides advantages of lengthening its life time and improving uniformity of luminance.

What is claimed is:

1. A liquid crystal display device including

a liquid crystal display panel having a liquid crystal layer sandwiched between a pair of transparent substrates, at least one of said pair of transparent substrates having patterned electrodes on an inner surface thereof, and

a backlight disposed behind said liquid crystal display panel,

said backlight comprising:

at least one discharge tube including a sealed-off transparent tube body, a phosphor film formed on an inner surface of said sealed-off transparent tube body, and a discharge gas sealed within said sealed-off transparent tube body; and

a plurality of electrodes spaced in a direction of an axis of said sealed-off transparent tube body and positioned at least partially around a circumference of said sealed-off transparent tube body,

wherein at least two adjacent ones of said plurality of electrodes are supplied with voltages opposite in phase from each other, respectively, and

said voltages opposite in phase from each other are supplied from two power sources, respectively.

2. A liquid crystal display device including

a liquid crystal display panel having a liquid crystal layer sandwiched between a pair of transparent substrates, at least one of said pair of transparent substrates having patterned electrodes on an inner surface thereof, and

a backlight disposed behind said liquid crystal display panel,

said backlight comprising:

at least one discharge tube including a sealed-off transparent tube body, a phosphor film formed on an inner surface of said sealed-off transparent tube body, and a discharge gas sealed within said sealed-off transparent tube body; and

at least three electrodes spaced in a direction of an axis of said sealed-off transparent tube body and positioned at least partially around a circumference of said sealed-off transparent tube body,

wherein at least two adjacent ones of said at least three electrodes are supplied with voltages opposite in phase from each other, respectively.

3. A liquid crystal display device including

a liquid crystal display panel having a liquid crystal layer sandwiched between a pair of transparent substrates, at least one of said pair of transparent substrates having patterned electrodes on an inner surface thereof, and

a backlight disposed behind said liquid crystal display panel,

said backlight comprising:

at least one discharge tube including a sealed-off transparent tube body, a phosphor film formed on an inner surface of said sealed-off transparent tube body, and a discharge gas sealed within said sealed-off transparent tube body; and

a plurality of electrodes spaced in a direction of an axis of said sealed-off transparent tube body and positioned at least partially around a circumference of said sealed-off transparent tube body,

wherein at least two adjacent ones of said plurality of electrodes are supplied with voltages opposite in phase from each other, respectively, and

wherein lamp cables electrically connected to said at least two adjacent ones of said plurality of electrodes are substantially equal in length.

4. A liquid crystal display device including a liquid crystal display panel having a liquid crystal layer sandwiched between a pair of transparent substrates, at least one of said pair of transparent substrates having patterned electrodes on an inner surface thereof, and

a backlight disposed behind said liquid crystal display panel,

said backlight comprising:

at least one discharge tube including a sealed-off transparent tube body, a phosphor film formed on an inner surface of said sealed-off transparent tube body, and a discharge gas sealed within said sealed-off transparent tube body;

a plurality of electrodes spaced in a direction of an axis of said sealed-off transparent tube body and positioned at least partially around a circumference of said sealed-off transparent tube body; and

at least one conductor disposed symmetrically with respect to a plane passing through a center of a length of said at least one discharge tube and perpendicular to a direction of said length in a vicinity of said at least one discharge tube,

wherein at least two adjacent ones of said plurality of electrodes are supplied with voltages opposite in phase from each other, respectively.

5. A liquid crystal display device including

a liquid crystal display panel having a liquid crystal layer sandwiched between a pair of transparent substrates, at least one of said pair of transparent substrates having patterned electrodes on an inner surface thereof, and

a backlight disposed behind said liquid crystal display panel,

said backlight comprising:

at least one discharge tube including a sealed-off transparent tube body, a phosphor film formed on an inner surface of said sealed-off transparent tube body, and a discharge gas sealed within said sealed-off transparent tube body; and

a plurality of electrodes spaced in a direction of an axis of said sealed-off transparent tube body and positioned at least partially around a circumference of said sealed-off transparent tube body,

wherein at least two adjacent ones of said plurality of electrodes are supplied with voltages opposite in phase from each other, respectively, and

wherein an impedance formed in said sealed-off transparent tube body between said at least two adjacent ones

of said plurality of electrodes is not higher than one tenth of an impedance formed by a stray capacitance around said sealed-off transparent tube body.

* * * * *

专利名称(译)	具有改进的背光的液晶显示装置		
公开(公告)号	US20050280625A1	公开(公告)日	2005-12-22
申请号	US11/211582	申请日	2005-08-26
[标]申请(专利权)人(译)	株式会社日立制作所 日立电子设备美国		
申请(专利权)人(译)	HITACHI, LTD. 日立电子器件., LTD.		
当前申请(专利权)人(译)	HITACHI, LTD. 日立电子器件., LTD.		
[标]发明人	YAJIMA TOSHIHIRO NISHIYAMA SEIICHI TAKAKU SHIGETAKE TAKEDA YOSHIHARU MIKOSHIBA SHIGEO SHIGA TOMOKAZU HASHIMOTO KOJI BABA YUSUKE		
发明人	YAJIMA, TOSHIHIRO NISHIYAMA, SEIICHI TAKAKU, SHIGETAKE TAKEDA, YOSHIHARU MIKOSHIBA, SHIGEO SHIGA, TOMOKAZU HASHIMOTO, KOJI BABA, YUSUKE		
IPC分类号	G02F1/13357 H05B41/24 G09G3/36		
CPC分类号	G02F1/133604 G02F1/133605 G02F1/133608 G02F2001/133317 G02F2001/13332 H05B41/2822 G02F2001/133612 G09G3/3406 G09G2320/0233 H01J65/046 H05B41/245 G02F2001/133334		
优先权	2000146500 2000-05-18 JP		
其他公开文献	US7218308		
外部链接	Espacenet USPTO		

摘要(译)

一种液晶显示装置，包括：液晶显示面板，具有夹在一对透明基板之间的液晶层，所述透明基板中的至少一个在其内表面上具有图案化电极，以及设置在所述液晶显示面板后面的背光。该背光源具有至少一个放电管，该放电管包括密封的透明管，在密封的透明管的内表面上形成的荧光膜，以及在密封的透明管内的放电气体和在一个方向上间隔开的多个电极密封透明管的轴线的一部分，至少部分地围绕密封的透明管的圆周定位。向多个电极中的至少两个相邻电极分别提供频率彼此不同的交流电压。

