



US008358392B2

(12) **United States Patent**  
**Suzuki et al.**

(10) **Patent No.:** **US 8,358,392 B2**  
(45) **Date of Patent:** **Jan. 22, 2013**

(54) **LATERAL ELECTRIC FIELD TYPE  
ACTIVE-MATRIX ADDRESSING LIQUID  
CRYSTAL DISPLAY DEVICE**

6,744,482 B2\* 6/2004 Matsumoto et al. .... 349/141

**FOREIGN PATENT DOCUMENTS**

(75) Inventors: **Teruaki Suzuki**, Kanagawa (JP);  
**Shinichi Nishida**, Kanagawa (JP)

JP	56-91277	7/1981
JP	07-036058	2/1995
JP	2001-222030	8/2001
JP	2005-195927	7/2005

(73) Assignee: **NLT Technologies, Ltd.**, Kanagawa (JP)

\* cited by examiner

(\* ) Notice: Subject to any disclaimer, the term of this patent is extended or adjusted under 35 U.S.C. 154(b) by 556 days.

*Primary Examiner* — Uyen Chau N Le  
*Assistant Examiner* — Michael Mooney

(21) Appl. No.: **12/249,465**

(74) *Attorney, Agent, or Firm* — Young & Thompson

(22) Filed: **Oct. 10, 2008**

(57) **ABSTRACT**

(65) **Prior Publication Data**  
US 2009/0103035 A1 Apr. 23, 2009

A lateral electric field type active-matrix addressing liquid crystal display device suppresses the lateral cross talk induced by the coupling capacitances (i.e., the parasitic capacitances) between the drain bus lines and the common bus line corresponding thereto with a simple structure. In each of the pixel electrodes, at least one electrically isolated light-shielding electrode is formed to extend along the drain bus lines that define the pixel electrode near the same drain bus lines. The light-shielding electrode is overlapped with a part of a corresponding one of the pixel electrodes to the pixel region in such a way that an insulating film intervenes between the light-shielding electrode and the part, the part extending along these drain bus lines in the vicinities thereof. The light-shielding electrode may be electrically connected to the corresponding one of the pixel electrodes at a point in the pixel region.

(30) **Foreign Application Priority Data**  
Oct. 23, 2007 (JP) ..... 2007-275702

(51) **Int. Cl.**  
**G02F 1/1333** (2006.01)  
**G02F 1/1343** (2006.01)  
(52) **U.S. Cl.** ..... **349/141**; 349/110; 349/139; 349/143  
(58) **Field of Classification Search** ..... 349/110,  
349/139, 141, 143  
See application file for complete search history.

(56) **References Cited**

**U.S. PATENT DOCUMENTS**  
3,807,831 A 4/1974 Soref

**8 Claims, 10 Drawing Sheets**

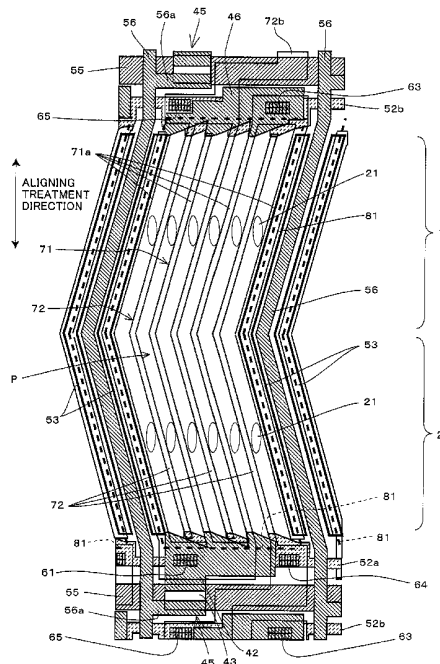



FIG. 2  
RELATED ART

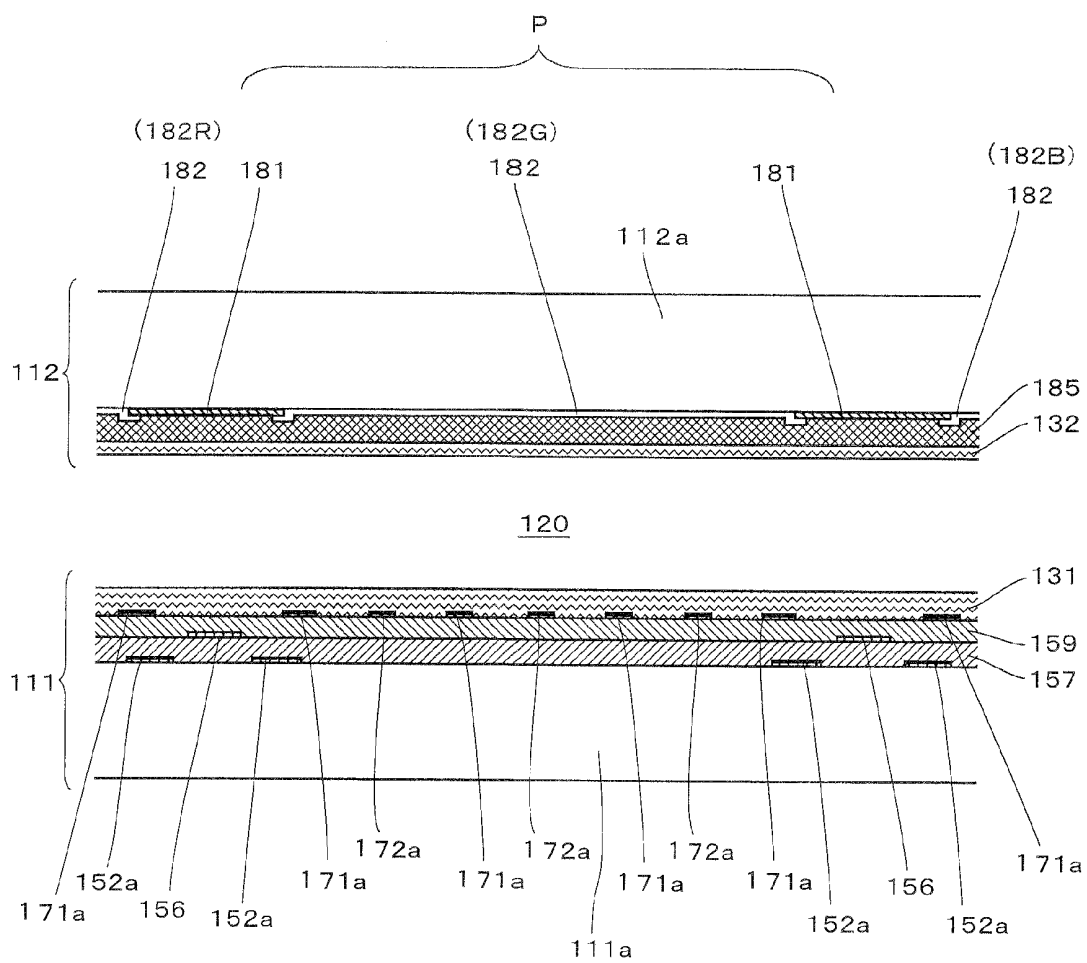



FIG. 4

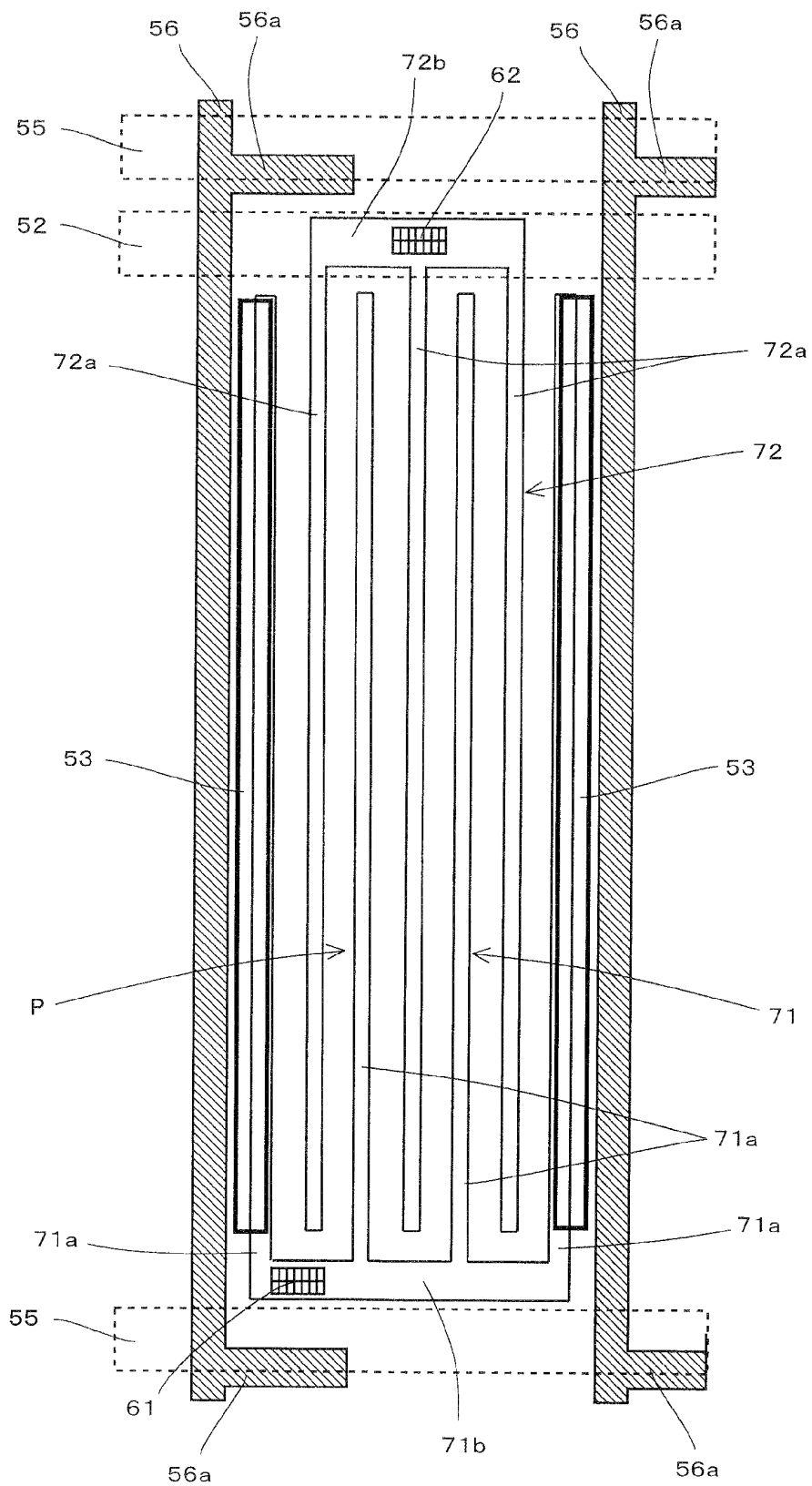

FIG. 5

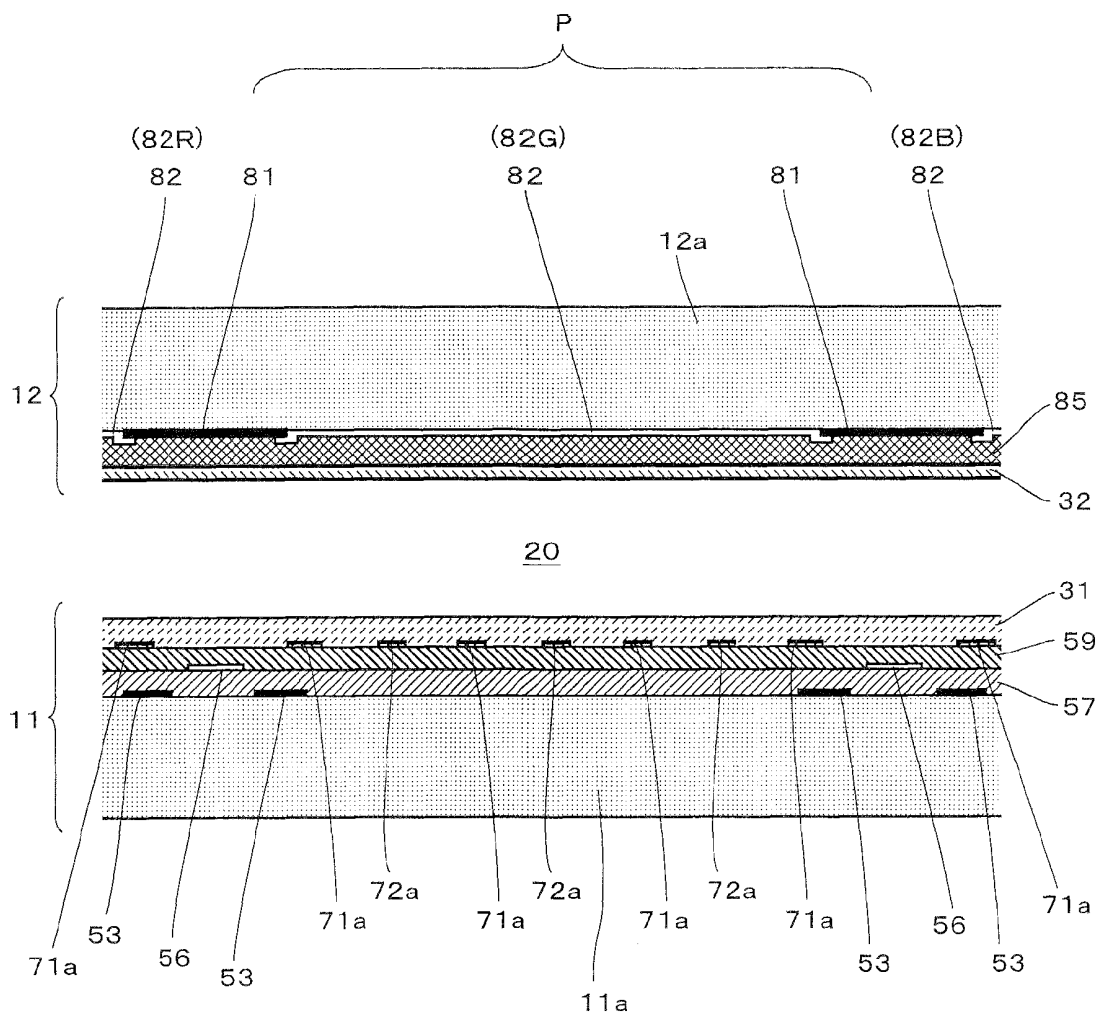

FIG. 6

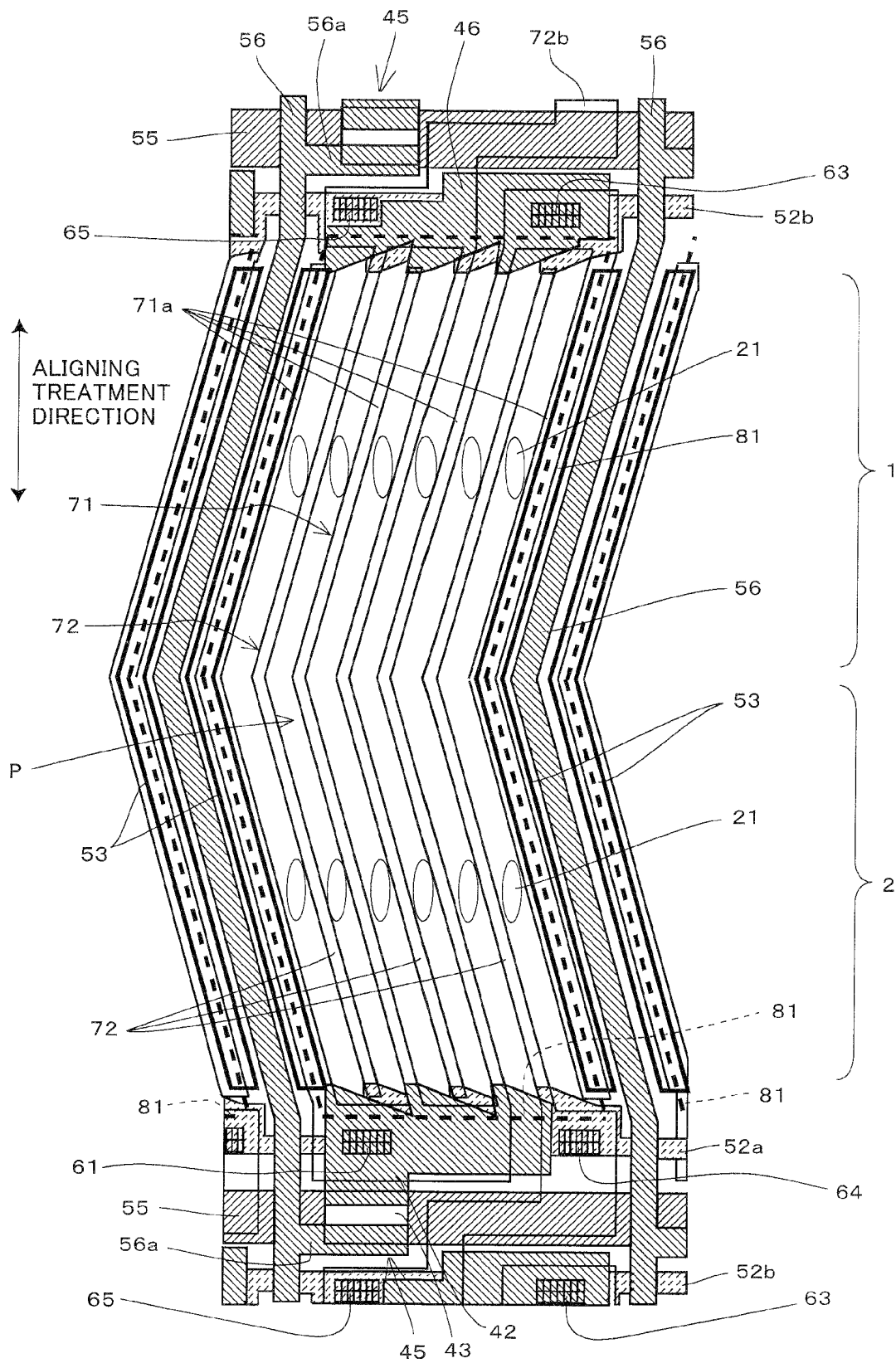

FIG. 7

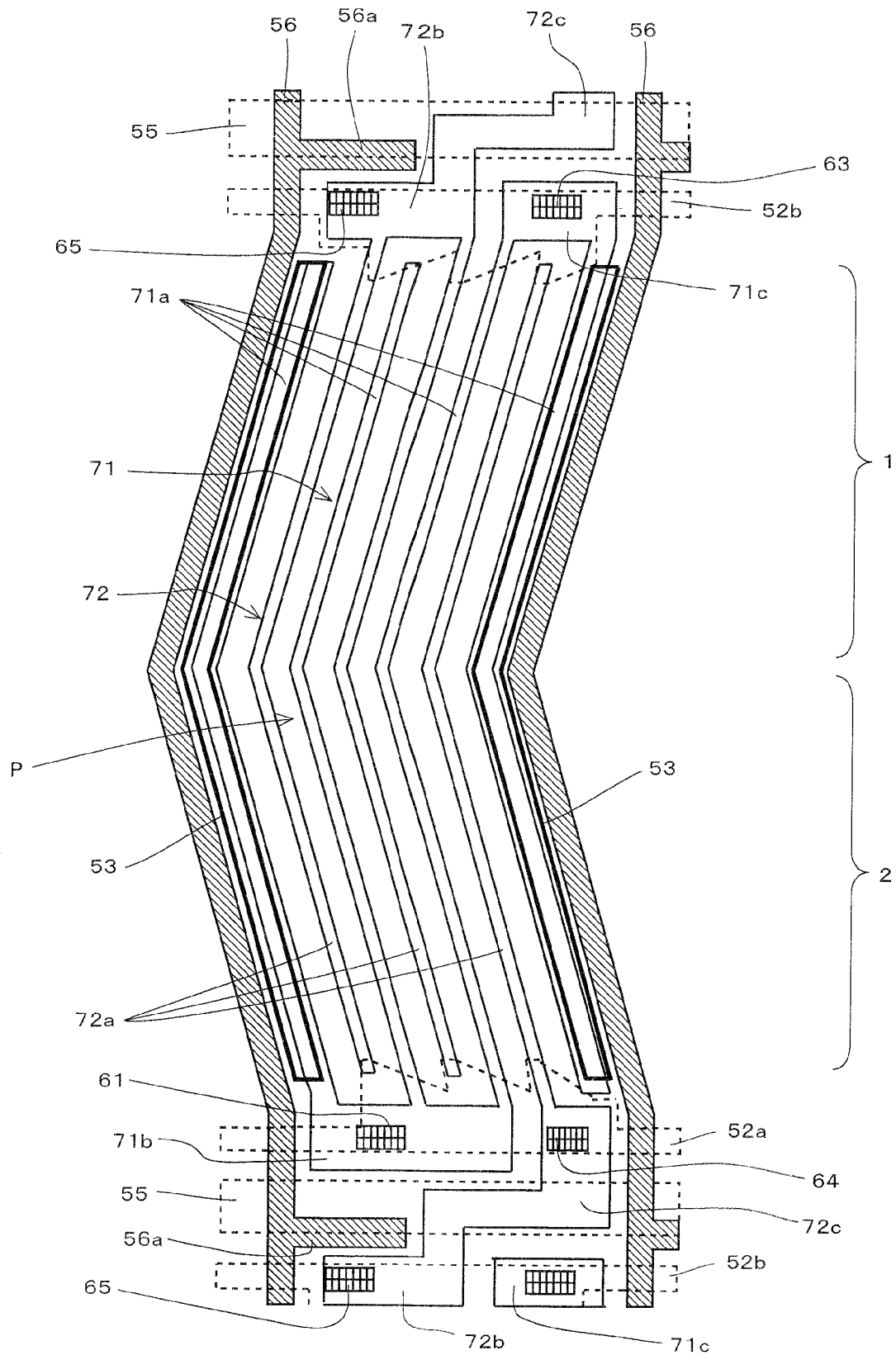

FIG. 8A

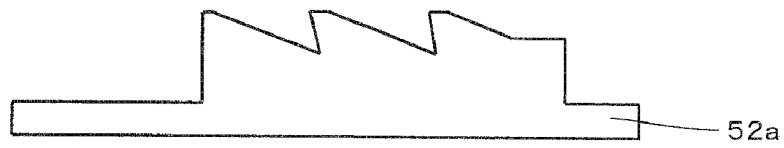

FIG. 8B

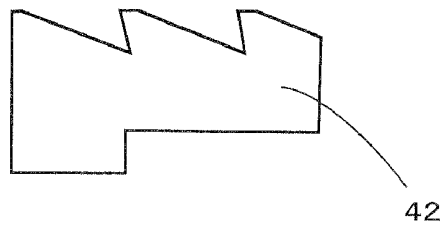

FIG. 8C



FIG. 8D

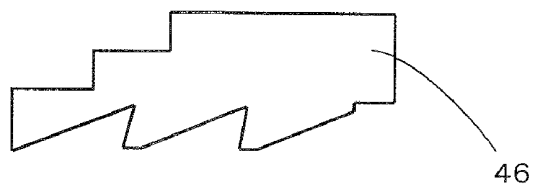

FIG. 9

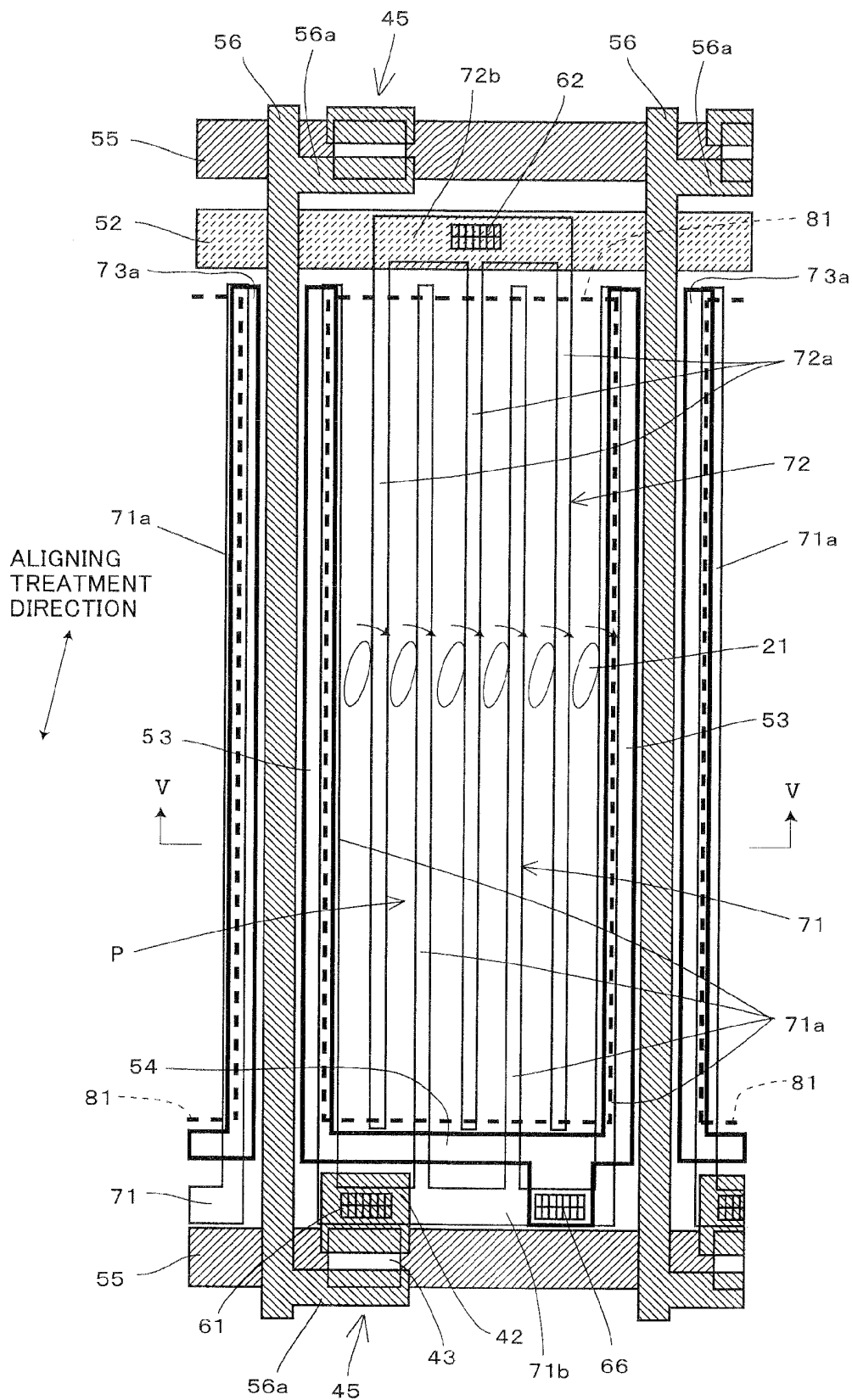
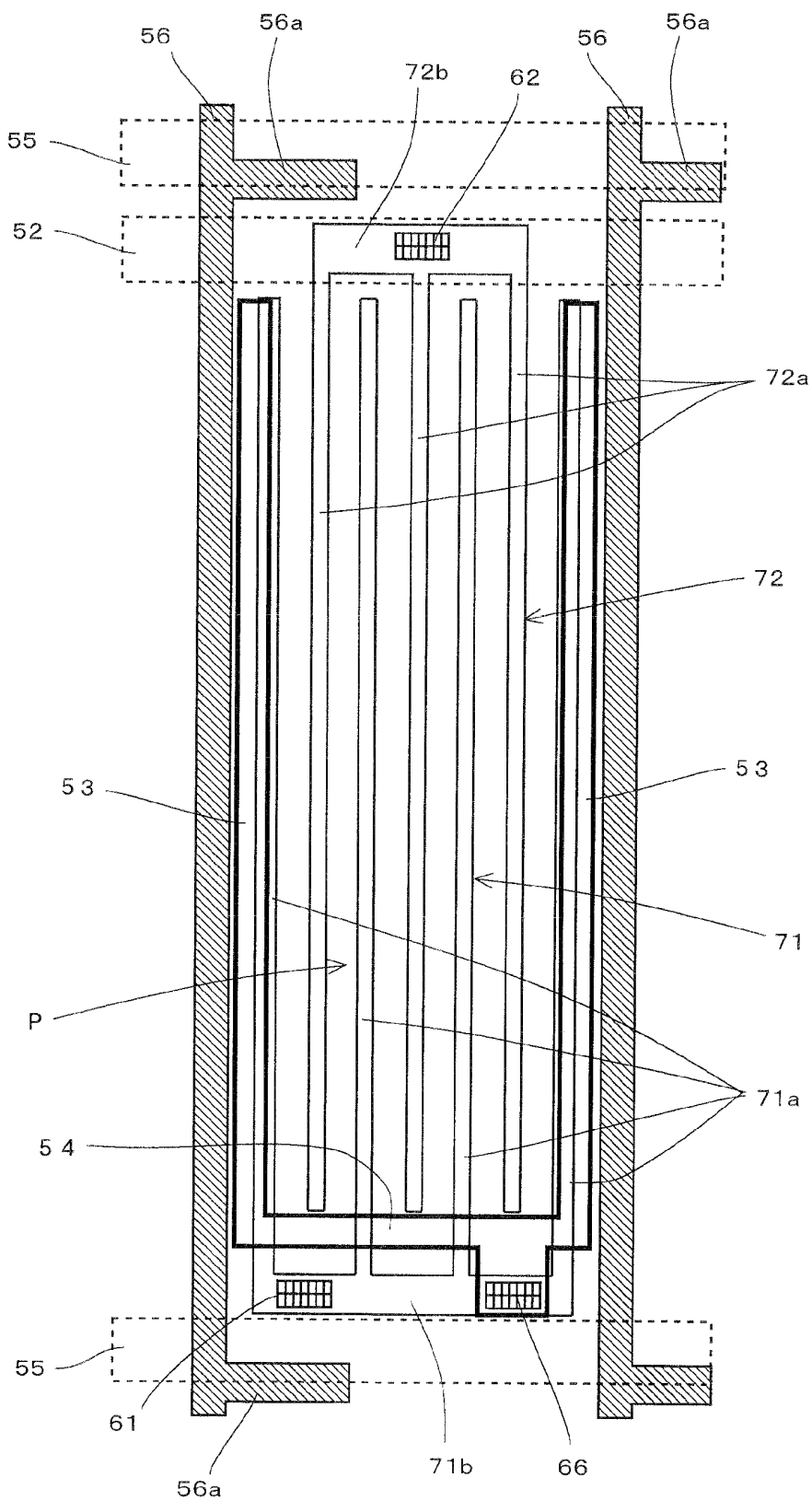

FIG. 10



**LATERAL ELECTRIC FIELD TYPE  
ACTIVE-MATRIX ADDRESSING LIQUID  
CRYSTAL DISPLAY DEVICE**

BACKGROUND OF THE INVENTION

1. Field of the Invention

The present invention relates to a Liquid crystal Display (LCD) device and more particularly, to an active-matrix addressing LCD device of the lateral electric field type, such as the In-Plane Switching (IPS) type.

2. Description of the Related Art

Generally, the LCD device has features, such as low profile, reduced weight, and low power consumption. In particular, the active-matrix addressing LCD device that drives the respective pixels arranged in a matrix array by the active elements has ever been recognized as a high image quality flat-panel display device. Especially, the active-matrix addressing LCD device using thin-film transistors (TFTs) as the active elements for switching the respective pixels has been extensively diffused.

Most of active-matrix addressing LCD devices, which utilizes the electrooptic effects of the TN (Twisted Nematic) type liquid crystal material sandwiched by two substrates, display images by the application of an electric field approximately vertical to the main surfaces of the substrates across the liquid crystal material to thereby cause displacement of the liquid crystal molecules. These LCD devices are termed the "vertical electric field" type. On the other hand, some of the active-matrix addressing LCD devices display images by the application of an electric field approximately parallel to the main surfaces of the substrates across the liquid crystal material to thereby cause displacement of the liquid crystal molecules in the planes parallel to the main surfaces. These LCD devices have been known also, which are termed the "lateral electric field" type. Various improvements have ever been made not only for the vertical electric field type LCD devices but also for the lateral electric field type ones. Some of the improvements made for the latter will be exemplified below.

A structure using comb-tooth-like electrodes mated with each other in the lateral electric field type LCD device is disclosed in the Patent Document 1 (i.e., U.S. Pat. No. 3,807, 831) issued in 1974 (see claim 1, FIGS. 1 to 4 and FIG. 11).

A technique using comb-tooth-like electrodes mated with each other similar to those in the Patent Document 1 in the active-matrix addressing LCD device utilizing the electrooptic effects of the TN type liquid crystal material is disclosed in the Patent Document 2 (i.e., Japanese Unexamined Patent Publication No. 56-091277) published in 1981 (see claim 2, FIG. 7 and FIGS. 9 to 13). This technique reduces the parasitic capacitance between the common electrode(s) and the drain bus lines, or that between the common electrode(s) and the gate bus lines.

A technique that realizes a lateral electric field type LCD device without using the comb-tooth-like electrodes in the active-matrix addressing LCD device using TFTs is disclosed in the Patent Document 3 (i.e., Japanese Unexamined Patent Publication No. 7-036058) published in 1995 (see claims 1 and 5, FIGS. 1 to 23). With this technique, the common electrode(s) and the image signal electrodes or the common electrode(s) and the liquid crystal driving electrodes are formed on different layers in such a way that an insulating film intervenes between them, and at the same time, the common electrode(s) or the liquid crystal driving electrodes is/are formed to be ring-, cross-, T-, ?-, H-, or ladder-shaped.

A technique that the comb-tooth-like electrodes for driving the liquid crystal material (i.e., the pixel electrodes and the common electrode(s)) are formed by a transparent conductive material or materials in such a way as to be placed on an upper layer than the drain bus lines (or the data bus lines), in other words, to be placed nearer to the liquid crystal layer than the drain or data bus Lines, is disclosed in the Patent Document 4 (i.e., Japanese Unexamined Patent Publication No. 2001-222030) published in 2001 (see abstract and FIGS. 3 to 5).

FIG. 1 is a partial plan view showing an example of the structure of the first substrate (i.e., the active-matrix substrate) used in the related-art lateral electric field type LCD device disclosed in the Patent Document 4. FIG. 2 is a cross-sectional view of the LCD device along the line II-II in FIG. 1. These two figures show the structure of one of the pixel regions.

The first substrate 111 of the related-art LCD device shown in FIGS. 1 and 2 comprises gate bus lines 155 that are extended along the lateral (horizontal) direction of FIG. 1 and arranged at equal intervals along the longitudinal (vertical) direction of the same figure, and drain bus lines 156 that are extended along the longitudinal direction of FIG. 1 and arranged at equal intervals along the lateral direction of the same figure. A pixel region P is formed in each of the approximately rectangular areas defined by the gate bus lines 155 and the drain bus lines 156. These pixel regions P (i.e., the pixels) are arranged in a matrix array as a whole.

Further, the first substrate 111 of this related-art LCD device comprises common bus lines 152, each of which is extended in parallel to a corresponding one of the gate bus lines 155. These common bus lines 152 are provided for electrical interconnection among the common electrodes 172 formed in the respective pixel regions P. Each of the common bus lines 152 is located near the upper end of each pixel region P and is apart from a corresponding one of the gate bus lines 155 at a predetermined distance. The gate bus lines 155, the drain bus lines 156, and the common bus lines 152 are made of opaque metallic materials, respectively.

In each of the pixel regions P, the corresponding common bus line 152 comprises two belt-shaped light-shielding parts 152a that extend respectively along the two drain bus lines 156 that define the pixel region P. These two light-shielding parts 152a are united with the common bus line 152. The light-shielding part 152a positioned at the left side of the pixel region P is adjacent to the right edge of the drain bus line 156 placed at the left side of the pixel region P. The light-shielding part 152a positioned at the right side of the pixel region P is adjacent to the left edge of the drain bus line 156 placed at the right side of the pixel region P. These two light-shielding parts 152a have the same plan shape or pattern.

For each of the pixel regions P, a TFT 145 is formed near the intersection of the corresponding gate bus line 155 and the corresponding drain bus line 156. The TFT 145 is formed by a gate electrode (not shown) united with the corresponding gate bus line 155; an island-shaped semiconductor film 143 overlapped with the gate electrode in such a way that a gate insulating film 157 intervenes between them; a drain electrode 156a united with the corresponding drain bus line 156 and overlapped with the semiconductor film 143; and a source electrode 142 formed to be opposite to the drain electrode 156a at a predetermined distance and overlapped with the semiconductor film 143. The gate electrode, the drain electrode 156a, and the source electrode 142 are made of opaque metallic materials, respectively.

In each of the pixel regions P, a pixel electrode 171 and a common electrode 172 for generating liquid crystal driving electric field are formed. The pixel electrode 171 and the

common electrode **172**, each of which is made of a transparent conductive material, have comb-tooth-like plan shapes.

The pixel electrode **171** comprises a belt-shaped base **171b** placed on the side of the TFT **145** (i.e., the TFT side) in the pixel region P, and four comb-tooth-like parts **171a** protruding from the base **171b** toward the opposite side to the TFT **145** (toward the upper side in FIG. 1) in the pixel region P. The four comb-tooth-like parts **171a** are extended in parallel to the drain bus lines **156** and are arranged along the base **171b** (along the lateral direction in FIG. 1) at equal intervals. The top ends of the respective comb-tooth-like parts **171a** are located near the corresponding common bus line **152**. Two of the comb-tooth-like parts **171a** placed at outer positions are respectively overlapped with the corresponding light-shielding parts **152a** existing near the two drain bus lines **156** that define the pixel region P. The pixel electrode **171** is electrically connected to the source electrode **142** of the corresponding TFT **145** at the base **171b** by way of a corresponding one of contact holes **161**.

The common electrode **172** comprises a belt-shaped base **172b** placed on the opposite side of the TFT **145** in the pixel region P, and three comb-tooth-like parts **172a** protruding from the base **172b** toward the side of the TFT **145** (toward the lower side in FIG. 1) in the pixel region P. The three comb-tooth-like parts **172a** are extended in parallel to the drain bus lines **156** and are arranged along the base **172b** (along the lateral direction in FIG. 1) at equal intervals. The top ends of the respective comb-tooth-like parts **172a** are located near the base **171b** of the pixel electrode **171**. The three comb-tooth-like parts **172a** and the four comb-tooth-like parts **171a** are arranged alternately along the gate and common bus lines **155** and **152**. Therefore, it may be said that these comb-tooth-like parts **172a** and **171a** are mated with each other. The common electrode **172** is electrically connected to the corresponding common bus line **152** at the base **172b** by way of a corresponding one of contact holes **162**.

As shown in FIG. 2, this related-art LCD device comprises the first substrate (i.e., the active-matrix substrate) **111** having the structure of FIG. 1, a second substrate (i.e., an opposite substrate) **112** opposed to the first substrate **111** at a predetermined gap, and a liquid crystal layer **120** placed between the substrates **111** and **112**.

The gate bus lines **155**, the common bus lines **152**, the light-shielding parts **152a**, and the gate electrodes of the TFTs **145** are formed on the surface of the glass plate **111a** of the first substrate **111**. The gate insulating film **157** is formed on the surface of the glass plate **111a** to cover the gate bus lines **155**, the common bus lines **152**, the light-shielding parts **152a**, and the gate electrodes. (Only the light-shielding parts **152a** are shown in FIG. 2.) Each of the gate electrodes is united with a corresponding one of the gate bus lines **155**. The drain bus lines **156**, the semiconductor films **143** of the TFTs **145**, the drain electrodes **156a**, and the source electrodes **142** are formed on the gate insulating film **157**. A protective insulating film **159** is formed on the gate insulating film **157** to cover the drain bus lines **156**, the semiconductor films **143**, the drain electrodes **156a**, and the source electrodes **142**. (Only the drain bus lines **156** are shown in FIG. 2.) The pixel electrodes **171** and the common electrodes **172** are formed on the protective insulating film **159**. (Only the comb-tooth-like parts **171a** of the pixel electrode **171** and the comb-tooth-like parts **172a** of the common electrode **172** are shown in FIG. 2.)

As explained above, the common bus lines **152** are located on the surface of the glass plate **111a** and the drain bus lines **156** are located on the gate insulating film **157**. Therefore, the common bus lines **152** are placed on a lower layer than the drain bus lines **156**, in other words, on a further layer from the

liquid crystal layer **120** than the drain bus lines **156**. Similarly, since the gate bus lines **155** are located on the surface of the glass plate **111a**, the gate bus lines **155** also are placed on a lower layer than the drain bus lines **156**, in other words, on a further layer from the liquid crystal layer **120** than the drain bus lines **156**. Because the pixel electrodes **171** and the common electrodes **172** are formed on the protective insulating film **159**, the pixel and common electrodes **171** and **172** are placed on an upper layer than the drain bus lines **156**, in other words, on a nearer layer to the liquid crystal layer **120** than the drain bus lines **156**.

On the surface (i.e., the inner face) of the first substrate **111** having the above-described structure, in other words, on the protective insulating film **159**, an alignment film **131** made of an organic polymer is formed. Therefore, the pixel electrodes **171** and the common electrodes **172** are covered with the alignment film **131**. The surface of the alignment film **131** is subjected to a predetermined aligning treatment.

On the other hand, a color layer **182** including the three primary colors of red (R), green (G) and blue (B) is formed on the surface of the glass plate **112a** of the second substrate **112** corresponding to the respective pixel regions P. A light-shielding black matrix layer **181** is formed on the surface of the glass plate **112a** in the remaining region excluding the regions corresponding to the pixel regions P. The color layer **182** is formed by a red color sublayer **182R**, a green color sublayer **182G**, and a blue color sublayer **182B**, each of which has been patterned to have a predetermined shape. The plan shape or pattern of the black matrix **181** is determined in such a way as to cover the structural elements formed on the first substrate **111** by opaque metallic materials (i.e., the gate bus lines **155**, the drain bus lines **156**, the common bus lines **152**, the light-shielding parts **152a**, and the TFTs **145**) and to define rectangular openings (i.e., light transmission areas) in the respective pixel regions P. The color layer **182** is selectively placed in these openings or light transmission areas.

The color layer **182** and the black matrix layer **181** are covered with an overcoat film **185**. The overcoat film **185**, which is formed to cover the whole surface of the glass plate **112a**, is provided to protect the color layer **182** and the black matrix layer **181** and to planarize the level differences generated by the color layer **182** and the black matrix layer **181**. Columnar spacers (not shown) are formed on the black matrix layer **181** to keep the gap between the first and second substrates **111** and **112**.

On the surface (i.e., the inner face) of the second substrate **112** having the above-described structure, in other words, on the overcoat film **185**, an alignment film **132** made of an organic polymer is formed. Therefore, the columnar spacers are covered with the alignment film **132**. The surface of the alignment film **132** is subjected to a predetermined aligning treatment.

The first substrate (i.e., the active-matrix substrate) **111** and the second substrate (i.e., the opposite substrate) **112** are superposed on each other at a predetermined gap in such a way that their surfaces on which the alignment films **131** and **132** are respectively formed are directed inward and opposed to each other. A liquid crystal material is confined in the space between the substrates **111** and **112**, forming the liquid crystal layer **120**. In other words, the liquid crystal layer **120** is sandwiched and held by the substrates **111** and **112**. A pair of polarizer plates (not shown) is arranged on the outer surfaces of the first and second substrates **111** and **112** (i.e., the backs of the glass plates **111a** and **112a**), respectively.

Because the surfaces of the alignment films **131** and **132** have been subjected to the predetermined aligning treatments, the liquid crystal molecules **121** existing in the liquid

crystal layer **120** are aligned in parallel along a predetermined direction shifted at a fixed angle (e.g., approximately  $15^\circ$  clockwise) from the vertical or longitudinal direction of FIG. **1** when no electric field is applied, as shown by the arrow in FIG. **1**. This means that the initial alignment direction of the liquid crystal molecules **121** is defined at the direction indicated by the arrow in FIG. **1**. Moreover, the transmission axes of the pair of polarizer plates are crossed at right angles. The transmission axis of one of the pair of polarizer plates is in accordance with the alignment direction of the liquid crystal molecules **121** when no electric field is applied (i.e., the initial alignment direction).

Next, a method of fabricating the related-art LCD device shown in FIGS. **1** and **2** will be explained below.

The first substrate **111** is fabricated in the following way.

First, a chromium (Cr) film is formed on the whole surface of the glass plate **111a** and patterned to have a predetermined shape, thereby forming the gate bus lines **155**, the common bus lines **152**, and the light-shielding parts **152a** on the surface of the glass plate **111a**. At this time, the gate electrodes also are formed in such a way as to be united with the corresponding gate bus lines **155**. Next, the gate insulating film **157**, which is made of silicon nitride ( $\text{SiN}_x$ ), is formed on the whole surface of the glass plate **111a** to cover the gate electrodes, the gate bus lines **155**, the common bus lines **152**, and the light-shielding parts **152a**.

Subsequently, an amorphous silicon (a-Si) film is formed on the gate insulating film **157** and patterned to result in island-like parts, thereby forming the island-shaped semiconductor films **143** for the TFTs **145**. Each of the island-shaped semiconductor films **143** is overlapped with a corresponding one of the gate bus lines **155** in such a way that the gate insulating film **157** intervenes between them. Moreover, a Cr film is formed on the gate insulating film **157** and patterned, thereby forming the drain bus lines **156**, the drain electrodes **156a**, and the source electrodes **142** on the gate insulating film **157**. Thereafter, the protective insulating film **159**, which is made of  $\text{SiN}_x$ , is formed on the whole surface of the glass plate **111a**, covering the drain bus lines **156**, the drain electrodes **156a**, and the source electrodes **142**.

Following this, the protective insulating film **159** is selectively removed at the predetermined positions superposed on the respective source electrodes **142**, thereby forming the contact holes **161** that reach the corresponding source electrodes **142**. Moreover, the protective insulating film **159** and the gate insulating film **157** are selectively removed at the predetermined positions superposed on the respective common bus lines **152**, thereby forming the contact holes **162** that reach the corresponding common bus lines **152**.

Thereafter, a transparent conductive film, which is made of ITO (Indium Tin Oxide) or the like, is formed on the protective insulating film **159** and patterned to have a predetermined shape, thereby forming the pixel electrodes **171** each having the comb-tooth-like parts **171a** and the common electrodes **172** each having the comb-tooth-like parts **172a** on the protective insulating film **159**. At this time, the pixel electrodes **171** are electrically connected to the corresponding source electrodes **142** by way of the corresponding contact holes **161**. The common electrodes **172** are electrically connected to the corresponding common bus lines **152** by way of the corresponding contact holes **162**. In this way, the first substrate **111** is fabricated.

The second substrate **112** is fabricated in the following way.

First, the black matrix layer **181** and the color layer **182** each having the predetermined shape or pattern are formed on the surface of the glass plate **112a**. When the color layer **182**

is formed, the red color sublayer **182R**, the green color sublayer **182G**, and the blue color sublayer **182B** each having a predetermined shape may be successively formed on the surface of the glass plate **112a** in an appropriate order. Next, the overcoat film **185** is formed on the whole surface of the glass plate **112a**, thereby covering the black matrix layer **181** and the color layer **182**. Thereafter, the columnar spacers (not shown) are formed on the overcoat film **185**. In this way, the second substrate **112** is fabricated.

Following this, the alignment films **131** and **132**, which are made of polyimide, are respectively formed on the surface of the first substrate **111** and the surface of the second substrate **112** fabricated in the above-described manners. The surfaces of the alignment films **131** and **132** are uniformly subjected to the predetermined aligning treatment.

Thereafter, the first and second substrates **111** and **112** are superposed on each other to have a predetermined gap such as  $4.0\ \mu\text{m}$ . Next, in a vacuum chamber (not shown), a predetermined nematic liquid crystal material whose refractive index anisotropy is, for example,  $0.075$  is injected into the space between the substrates **111** and **112** and then, the space is sealed. After the sealing operation of the space is completed, the polarizer plates (not shown) are respectively adhered onto the outer surfaces of the substrates **111** and **112**. As a result, the LCD panel is completed.

A predetermined driver LSI (Large-Scale Integrated Circuit) and a predetermined backlight unit are mounted on the LCD panel thus fabricated. As a result, the related-art LCD device having the structure shown in FIGS. **1** and **2** is completed.

With the related-art lateral electric field type LCD device shown in FIGS. **1** and **2**, the liquid crystal driving electric field is uniformly generated along the approximately lateral (horizontal) direction of FIG. **1** when a voltage is applied. For this reason, the liquid crystal molecules **121** aligned along the initial alignment direction (i.e., the direction indicated by the arrow in FIG. **1**) when no electric field is applied are rotated clockwise by the liquid crystal driving electric field, and as a result, the alignment state of the liquid crystal molecules **121** is changed. Since the transmittance in the respective pixel regions P (i.e., the respective pixels) is modulated by such the alignment state change of the liquid crystal molecules **121**, images can be displayed as desired.

Moreover, with the related-art lateral electric field type LCD device shown in FIGS. **1** and **2**, both of the pixel electrodes **171** and the common electrodes **172** for generating the liquid crystal driving electric field are made of a transparent conductive material and therefore, light penetrates through the regions where the pixel and common electrodes **171** and **172** are present. For this reason, the aperture ratio and the transmittance are improved compared with the case where the pixel electrodes **171** and the common electrodes **172** are made of an opaque metal or metals.

In addition, since the amount of the opaque metallic parts existing in the openings of the black matrix layer **181** is reduced in the above-described manner, the scattering of light caused by the edges of the opaque metallic parts and the alignment distortion of the liquid crystal molecules **121** caused by the level differences in the vicinities of the same edges are suppressed. The scattering of light and the alignment distortion of the liquid crystal molecules **121** will be a cause of optical leakage when black is displayed. However, with this related-art lateral electric field type LCD device, the scattering of light and the alignment distortion of the liquid crystal molecules **121** are suppressed and therefore, the display contrast is improved.

If the opaque metallic parts are present in the openings of the black matrix layer **181**, the incident light will be reflected by these opaque metallic parts when this related-art LCD device is used in a comparatively well-lighted place, and as a result, the "light place contrast" is likely to deteriorate conspicuously. However, this related-art LCD device does not include such the opaque metallic parts in the openings of the black matrix layer **181**. Accordingly, with this related-art LCD device, the light place contrast is prevented from deteriorating.

Furthermore, the two light-shielding parts **152a**, which are united with the corresponding common bus line **152** in the pixel region P as shown in FIG. 1, are respectively provided in the vicinities of the two drain bus lines **156** that define the pixel region P. The areas between the light-shielding parts **152a** and the corresponding drain bus lines **156** adjacent thereto are covered with the black matrix layer **181**. Therefore, the leakage of light induced by the leaked electric field from the respective drain bus lines **156** and the vertical cross talk are restrained.

With the related-art LCD device shown in FIGS. 1 and 2, the above-described advantages are obtained. However, the two light-shielding parts **152a** united with the corresponding common bus line **152** are respectively extended along the two drain bus lines **156** that define the pixel region P over a long distance in the vicinities of these drain bus lines **156**. Therefore, the coupling capacitances (i.e., the parasitic capacitances) between these two drain bus lines **156** and the corresponding common bus line **152** (i.e., the corresponding common electrode **172**) will be large.

For this reason, the effect of electric potential fluctuation (i.e., the effect of signal voltage change) on the drain bus lines **156** is likely to be transferred to the corresponding common electrode **172** by way of the corresponding common bus line **152**. In other words, the electric potential (which should be kept constant originally) of the common electrode **172** electrically connected to the corresponding common bus line **152** tends to fluctuate due to the electric potential fluctuation on the corresponding drain bus lines **156**. As a result, a problem that lateral cross talk is likely to occur arises.

#### SUMMARY OF THE INVENTION

The present invention was created to solve the above-described problem.

An object of the present invention is to provide a lateral electric field type active-matrix addressing LCD device that suppresses the lateral cross talk induced by the coupling capacitances (i.e., the parasitic capacitances) between the drain bus lines and the common bus line corresponding thereto with a simple structure.

Another object of the present invention is to provide a lateral electric field type active-matrix addressing LCD device having improved image quality compared with the above-described related-art LCD device shown in FIGS. 1 and 2.

The above objects together with others not specifically mentioned will become clear to those skilled in the art from the following description and the figures attached.

According to the first aspect of the present invention, a lateral electric field type active-matrix addressing LCD device is provided, which comprises:

a first substrate including gate bus lines, common bus lines parallel to the gate bus lines, and drain bus lines intersected with the gate bus lines and the common bus lines;

a second substrate held to be opposite to the first substrate at a predetermined gap;

a liquid crystal layer placed between the first substrate and the second substrate;

pixel regions defined by the gate bus lines and the drain bus lines to be arranged in a matrix array; and

each of the pixel regions including a switching element, a pixel electrode electrically connected to the switching element, and a common electrode electrically connected a corresponding one of the common bus lines;

wherein in each of the pixel regions, at least one light-shielding electrode is formed to extend along the drain bus lines that define the pixel electrode near the same drain bus lines;

the at least one light-shielding electrode is electrically isolated and is overlapped with at least one part of the pixel electrode corresponding to the pixel region in such a way that an insulating film intervenes between the at least one light-shielding electrode and the at least one part, wherein the at least one part is extended along the drain bus lines in their vicinities; and

liquid crystal molecules confined in the liquid crystal layer are rotated in planes approximately parallel to the first substrate, thereby displaying images.

With the lateral electric field type active-matrix addressing LCD device according to the first aspect of the present invention, in each of the pixel regions, the at least one light-shielding electrode is formed to extend along the drain bus lines that define the pixel electrode near the same drain bus lines. The at least one light-shielding electrode is electrically isolated and is overlapped with the at least one part of the corresponding pixel electrode to the pixel region in such a way that the insulating film intervenes between the at least one light-shielding electrode and the at least one part, wherein the at least one part is extended along the drain bus lines in their vicinities.

Therefore, in the operating state, the electric potential of the at least one light-shielding electrode will be close to that of the corresponding pixel electrode (which is equivalent to the signal voltage). For this reason, the electric potential difference(s) between the drain bus lines and the at least one light-shielding electrode corresponding thereto is/are very small, in other words, the coupling capacitances (i.e., the parasitic capacitances) between the drain bus lines and the at least one light-shielding electrode are very small.

On the other hand, with the related-art LCD device shown in FIGS. 1 and 2, the light-shielding parts **152a** are united with the corresponding common bus line **152** and therefore, the electric potential of the light-shielding parts **152a** will be equal to that of the corresponding common electrode **172**. Accordingly, the electric potential differences between the drain bus lines **156** and the common bus line **152** corresponding thereto will be equal to the differences between the electric potentials equivalent to the signal voltages supplied to the drain bus lines **156** and the electric potential of the common electrode **172**. This means that the coupling capacitances (i.e., the parasitic capacitances) between the drain bus lines **156** and the light-shielding parts **152a** corresponding thereto will be considerably large.

In this way, with the LCD device according to the first aspect of the invention, the coupling or parasitic capacitances between the drain bus lines and the at least one light-shielding electrode are considerably smaller than those between the drain bus lines **156** and the corresponding common bus line **152** (i.e., the corresponding light-shielding parts **152a**) of the related-art LCD device and therefore, the lateral cross talk is suppressed. Moreover, because of the suppression of the lateral cross talk, the image quality is improved.

According to the second aspect of the present invention, another lateral electric field type active-matrix addressing LCD device is provided, which comprises:

a first substrate including gate bus lines, common bus lines parallel to the gate bus lines, and drain bus lines intersected with the gate bus lines and the common bus lines;

a second substrate held to be opposite to the first substrate at a predetermined gap;

a liquid crystal layer placed between the first substrate and the second substrate;

pixel regions defined by the gate bus lines and the drain bus lines to be arranged in a matrix array; and

each of the pixel regions including a switching element, a pixel electrode electrically connected to the switching element, and a common electrode electrically connected a corresponding one of the common bus lines;

wherein in each of the pixel regions, at least one light-shielding electrode is formed to extend along the drain bus lines that define the pixel electrode near the same drain bus lines;

the at least one light-shielding electrode is overlapped with at least one part of the pixel electrode corresponding to the pixel region in such a way that an insulating film intervenes between the at least one light-shielding electrode and the at least one part, wherein the at least one part is extended along the drain bus lines in their vicinities;

the at least one light-shielding electrode is electrically connected to the pixel electrode corresponding to the pixel region at a position in the pixel region; and

liquid crystal molecules confined in the liquid crystal layer are rotated in planes approximately parallel to the first substrate, thereby displaying images.

With the lateral electric field type active-matrix addressing LCD device according to the second aspect of the present invention, the at least one light-shielding electrode is not electrically isolated but electrically connected to the pixel electrode corresponding to the pixel region at a position in the pixel region, which is different from the LCD device according to the first aspect of the invention. The other structure of the device of the second aspect is the same as that of the first aspect.

In this way, the at least one light-shielding electrode is electrically connected to the corresponding pixel electrode at a position in the pixel region and therefore, the electric potential of the at least one light-shielding electrode will be equal to that of the corresponding pixel electrode in the operating state. On the other hand, as explained for the LCD device according to the first aspect of the invention, the electric potential of the electrically floating light-shielding electrode will be close to that of the corresponding pixel electrode in the operating state. Thus, the at least one light-shielding electrode of the LCD device of the second aspect has an approximately the same function as that of the at least one light-shielding electrode of the LCD device of the first aspect.

Accordingly, with the LCD device of the second aspect also, the coupling or parasitic capacitances between the drain bus lines and the at least one light-shielding electrode are considerably smaller than those between the drain bus line **156** and the corresponding common bus line **152** (i.e., the corresponding light-shielding parts **152a**) of the related-art LCD device shown in FIGS. **1** and **2**, and as a result, the lateral cross talk is suppressed. Moreover, because of the suppression of the lateral cross talk, the image quality is improved.

In a preferred embodiment of the devices according to the first and second aspects of the invention, the at least one light-shielding electrode is placed on a different layer from that for the drain bus lines in such a way that an insulating film

intervenes between them. In this embodiment, it is preferred that the at least one light-shielding electrode is placed on a further layer from the liquid crystal layer than the drain bus lines, or on a same layer as that of the gate bus lines.

In another preferred embodiment of the devices according to the first and second aspects of the invention, the at least one part of the pixel electrode corresponding to the pixel region is comb-tooth-shaped, and the at least one light-shielding electrode is belt-shaped to extend along the drain bus lines.

In still another preferred embodiment of the devices according to the first and second aspects of the invention, the pixel electrode corresponding to the pixel region comprises comb-tooth-shaped parts extending along the drain bus lines;

two of the comb-tooth-shaped parts of the pixel electrode located at outer positions are used as the at least one part of the pixel electrode extending along the two drain bus lines that define the pixel electrode in the vicinities of the same drain bus lines; and

the two light-shielding electrodes are belt-shaped to extend along the two drain bus lines that define the pixel electrode, respectively.

In a further preferred embodiment of the devices according to the first and second aspects of the invention, the drain bus lines are bent to have approximately V-like shapes in accordance with the respective pixel regions, and the pixel electrodes and the common electrodes are bent to have approximately V-like shapes corresponding to the drain bus lines.

In a still further preferred embodiment of the devices according to the first and second aspects of the invention, the pixel electrodes are placed on a different layer from that for the drain bus lines in such a way that an insulating film intervenes between them. In this embodiment, it is preferred that the pixel electrodes are placed on a nearer layer to the liquid crystal layer than the drain bus lines.

In a still further preferred embodiment of the devices according to the first and second aspects of the invention, the common electrodes are placed on a same layer as the pixel electrodes.

In a still further preferred embodiment of the devices according to the first and second aspects of the invention, the pixel electrodes and/or the common electrodes are made of a transparent conductive material or materials.

#### BRIEF DESCRIPTION OF THE DRAWINGS

In order that the present invention may be readily carried into effect, it will now be described with reference to the accompanying drawings.

FIG. **1** is a partial plan view showing an example of the structure of the first substrate (i.e., the active-matrix substrate) used in a related-art lateral electric field type active-matrix addressing LCD device.

FIG. **2** is a partial cross-sectional view along the line II-II in FIG. **1**.

FIG. **3** is a partial plan view showing the structure of the active-matrix substrate used in a lateral electric field type active-matrix addressing LCD device according to a first exemplary embodiment of the present invention.

FIG. **4** is an explanatory partial plan view showing the plan shapes of the pixel electrode and the common electrode used in the active-matrix substrate shown in FIG. **3**.

FIG. **5** is a partial cross-sectional view along the line V-V in FIG. **3**.

FIG. **6** is a partial plan view showing the structure of the active-matrix substrate used in a lateral electric field type active-matrix addressing LCD device according to a second exemplary embodiment of the present invention.

FIG. 7 is an explanatory partial plan view showing the plan shapes of the pixel electrode and the common electrode used in the active-matrix substrate shown in FIG. 6.

FIG. 8A is an explanatory plan view showing the plan shape of the widened part of one of the common bus lines used in the active-matrix substrate shown in FIG. 6.

FIG. 8B is an explanatory plan view showing the plan shape of the source electrode used in the active-matrix substrate shown in FIG. 6.

FIG. 8C is an explanatory plan view showing the plan shape of the widened part of the other of the common bus lines used in the active-matrix substrate shown in FIG. 6.

FIG. 8D is an explanatory plan view showing the plan shape of the auxiliary electrode used in the active-matrix substrate shown in FIG. 6.

FIG. 9 is a partial plan view showing the structure of the active-matrix substrate used in a lateral electric field type active-matrix addressing LCD device according to a third exemplary embodiment of the present invention.

FIG. 10 is an explanatory partial plan view showing the plan shapes of the pixel electrode and the common electrode used in the active-matrix substrate shown in FIG. 9.

#### DETAILED DESCRIPTION OF THE PREFERRED EMBODIMENTS

Preferred embodiments of the present invention will be described in detail below while referring to the drawings attached.

##### Structure of First Embodiment

FIGS. 3 to 5 show the structure of a lateral electric field (IPS) type active-matrix addressing LCD device according to a first exemplary embodiment of the present invention. These figures show the structure of one of the pixel regions.

The first substrate (i.e., the active-matrix substrate) 11 of the LCD device according to the first embodiment comprises gate bus lines 55 that are extended along the lateral (horizontal) direction of FIG. 3 and arranged at equal intervals along the longitudinal (vertical) direction thereof, and drain bus lines 56 that are extended along the longitudinal direction of FIG. 3 and arranged at equal intervals along the lateral direction thereof. A pixel region P is formed in each of the approximately rectangular regions defined by the gate bus lines 55 and the drain bus lines 56. These pixel regions P (i.e., the pixels) are arranged in a matrix array as a whole.

Further, the first substrate 11 of the LCD device according to the first embodiment comprises common bus lines 52, each of which is extended in parallel to a corresponding one of the gate bus lines 55. These common bus lines 52 are provided for electrical interconnection among the common electrodes 72 formed in the respective pixel regions P. Each of the common bus lines 52 is located near the upper end of each pixel region P and is apart from a corresponding one of the gate bus lines 55 at a predetermined distance. Here, one of the gate bus lines 55 is placed near the bottom of the pixel region P while a corresponding one of the common bus lines 52 is placed near the top of the pixel region P.

The gate bus lines 55, the drain bus lines 56, and the common bus lines 52 are made of opaque metallic materials, respectively.

In each of the pixel regions P, two belt-shaped (or stripe-shaped) light-shielding electrodes 53 extending respectively along the two drain bus lines 56 that define the pixel region P are provided. These light-shielding electrodes 53 are not elec-

trically connected to any other electrodes and any bus lines provided near the electrodes 53, and are electrically isolated.

As shown in FIG. 3, the light-shielding electrode 53 positioned at the left side of the pixel region P is adjacent to the right edge of the drain bus line 56 placed at the left of side of the pixel region P. This light-shielding electrode 53 is extended in parallel to this drain bus line 56 and is apart from the same at a predetermined distance. This light-shielding electrode 53 is not overlapped with the corresponding common bus line 52 and the corresponding gate bus line 55 to the pixel region P.

The light-shielding electrode 53 positioned at the right side of the pixel region P is adjacent to the left edge of the drain bus line 56 placed at the right side of the pixel region P. This light-shielding electrode 53 is extended in parallel to this drain bus line 56 and is apart from the same at a predetermined distance. This light-shielding electrode 53 is not overlapped with the corresponding common bus line 52 and the corresponding gate bus line 55 to the pixel region P.

For each of the pixel regions P, a TFT 45 is formed near the intersection of the corresponding gate bus line 55 and the corresponding drain bus line 56. The TFT 45 is formed by a gate electrode (not shown) united with the corresponding gate bus line 55; an island-shaped semiconductor film 43 overlapped with the gate electrode in such a way that a gate insulating film 57 intervenes between them; a drain electrode 56a united with the corresponding drain bus line 56 and overlapped with the semiconductor film 43; and a source electrode 42 formed to be opposite to the drain electrode 56a at a predetermined distance and overlapped with the semiconductor film 43. The gate electrode, the drain electrode 56a, and the source electrode 42 are made of opaque metallic materials, respectively.

Moreover, in each of the pixel regions P, a pixel electrode 71 and a common electrode 72 for generating liquid crystal driving electric field are formed, as shown in FIGS. 3 and 4. The pixel electrode 71 and the common electrode 72, each of which is made of a transparent conductive material, have comb-tooth-like plan shapes.

As shown in FIG. 3, the pixel electrode 71 comprises a belt-shaped base 71b placed on the side of the TFT 45 in the pixel region P, and four comb-tooth-like parts 71a protruding from the base 71b toward the opposite side to the TFT 45 (toward the upper side in FIG. 3) in the pixel region P. The base 71b is not overlapped with the corresponding gate bus line 55 but is overlapped with the source electrode 42 of the corresponding TFT 45. All the comb-tooth-like parts 71a are extended in parallel to the two drain bus lines 56 that define the pixel region P, and are arranged along the base 71b (along the lateral direction in FIG. 3) at equal intervals. The top ends of the respective comb-tooth-like parts 71a are located near the corresponding common bus line 52. Two of the comb-tooth-like parts 71a placed at outer positions are respectively overlapped with the two corresponding light-shielding electrodes 53 existing near the two drain bus lines 56 that define the pixel region P. This is to shield the light that leaks through the neighborhoods of the respective drain bus lines 56 by the light-shielding electrodes 53. The comb-tooth-like parts 71a are somewhat narrower in width than the light-shielding electrodes 53. The pixel electrode 71 is electrically connected to the source electrode 42 of the corresponding TFT 45 at the base 71b by way of a corresponding one of contact holes 61.

The common electrode 72 comprises a belt-shaped base 72b placed on the opposite side to the TFT 45 in the pixel region P, and three comb-tooth-like parts 72a protruding from the base 72b toward the side of the TFT 45 (toward the lower side in FIG. 3) in the pixel region P. The base 72b is entirely

overlapped with the corresponding common bus line **52**. All the comb-tooth-like parts **72a** are extended in parallel to the two drain bus lines **56** that define the pixel region P, and are arranged along the base **72b** (along the lateral direction in FIG. 3) at equal intervals. Accordingly, these comb-tooth-like parts **72a** are parallel to the comb-tooth-like parts **71a** of the pixel electrode **71** and the drain bus lines **56**. The top ends of the respective comb-tooth-like parts **72a** are located near the base **71b** of the pixel electrode **71**. The three comb-tooth-like parts **72a** and the four comb-tooth-like parts **71a** are arranged alternately along the gate and common bus lines **55** and **52**. Therefore, it may be said that these comb-tooth-like parts **72a** and **71a** are mated with each other. The common electrode **72** is electrically connected to the corresponding common bus line **52** at the base **72b** by way of a corresponding one of contact holes **62**.

As shown in FIG. 5, the LCD device according to the first embodiment comprises the first substrate (i.e., an active-matrix substrate) **11** having the structure of FIG. 3, a second substrate (i.e., an opposite substrate) **12** opposed to the first substrate **11** at a predetermined gap, and a liquid crystal layer **20** placed between the substrates **11** and **12**.

The gate bus lines **55**, the common bus lines **52**, the light-shielding electrodes **53**, and the gate electrodes of the TFTs **45** are formed on the surface of the glass plate **11a** of the first substrate **11**. The gate insulating film **57** is formed on the surface of the glass plate **11a** to cover the gate bus lines **55**, the common bus lines **52**, the light-shielding electrodes **53**, and the gate electrodes. (Only the light-shielding electrodes **53** are shown in FIG. 5.) The gate electrodes are united with the corresponding gate bus lines **55**. The drain bus lines **56**, the semiconductor films **43** of the TFTs **45**, the drain electrodes **56a**, and the source electrodes **42** are formed on the gate insulating film **57**. (Only the drain bus lines **56** are shown in FIG. 5.) A protective insulating film **59** is formed on the gate insulating film **57** to cover the drain bus lines **56**, the semiconductor films **43**, the drain electrodes **56a**, and the source electrodes **42**. The pixel electrodes **71** and the common electrodes **72** are formed on the protective insulating film **59**. (Only the comb-tooth-like parts **71a** of the pixel electrode **71** and the comb-tooth-like parts **72a** of the common electrode **72** are shown in FIG. 5.)

As explained above, the common bus lines **52** are formed on the surface of the glass plate **11a**, and the drain bus lines **56** are formed on the gate insulating film **57**. Therefore, the common bus lines **52** are placed on a lower layer than the drain bus lines **56** (in other words, on a further layer from the liquid crystal layer **20** than the drain bus lines **56**). Similarly, since the gate bus lines **55** are formed on the surface of the glass plate **11a**, the gate bus lines **55** also are placed on a lower layer than the drain bus lines **56** (in other words, on a further layer from the liquid crystal layer **20** than the drain bus lines **56**). The pixel electrodes **71** and the common electrodes **72** are formed on the protective insulating film **59** and therefore, the pixel and common electrodes **71** and **72** are placed on an upper layer than the drain bus lines **56** (in other words, on a nearer layer to the liquid crystal layer **20** than the drain bus lines **56**).

On the surface (i.e., the inner face) of the first substrate **11** having the above-described structure, in other words, on the protective insulating film **59**, an alignment film **31** made of an organic polymer is formed. Therefore, the pixel electrodes **71** and the common electrodes **72** are covered with the alignment film **31**. The surface of the alignment film **31** is subjected to a predetermined aligning treatment.

On the other hand, a color layer **82** including the three primary colors of red (R), green (G) and blue (B) is formed on

the surface of the glass plate **12a** of the second substrate **12** corresponding to the respective pixel regions P. A light-shielding black matrix layer **81** is formed on the surface of the glass plate **12a** in the remaining region excluding the regions corresponding to the pixel regions P. The color layer **82** is formed by a red color sublayer **82R**, a green color sublayer **82G**, and a blue color sublayer **82B**, each of which is patterned to have a predetermined shape. The plan shape or pattern of the black matrix **81** is determined in such a way as to cover the structural elements formed on the first substrate **11** by using opaque metallic materials (i.e., the gate bus lines **55**, the drain bus lines **56**, the common bus lines **52**, the light-shielding electrodes **53**, and the TFTs **45**) and to define rectangular openings (i.e., light transmission areas) in the respective pixel regions P. The color layer **82** is selectively placed in these openings or light transmission areas.

The color layer **82** and the black matrix layer **81** are covered with an overcoat film **85**. The overcoat film **85**, which is formed to cover the whole surface of the glass plate **12a**, is provided for protecting the color layer **82** and the black matrix layer **81** and for planarizing the level differences generated by the color layer **82** and the black matrix layer **81**. Columnar spacers (not shown) are arranged on the black matrix layer **81** to keep the gap between the first and second substrates **11** and **12**.

On the surface (i.e., the inner face) of the second substrate **12** having the above-described structure, in other words, on the overcoat film **85**, an alignment film **32** made of an organic polymer is formed. Therefore, the columnar spacers are covered with the alignment film **32**. The surface of the alignment film **32** is subjected to a predetermined aligning treatment.

The first substrate (i.e., the active-matrix substrate) **11** and the second substrate (i.e., the opposite substrate) **12** are superposed on each other at a predetermined gap in such a way that their surfaces on which the alignment films **31** and **32** are respectively formed are directed inward and opposed to each other. A liquid crystal material is confined in the space between the first and second substrates **11** and **12**, forming the liquid crystal layer **20**. In other words, the liquid crystal layer **20** is sandwiched and held by these two substrates **11** and **12**. A pair of polarizer plates (not shown) is arranged on the outer surfaces of the substrates **11** and **12** (i.e., the backs of the glass plates **11a** and **12a**), respectively.

Since the surfaces of the alignment films **31** and **32** are respectively subjected to the predetermined aligning treatments, the liquid crystal molecules **21** existing in the liquid crystal layer **20** are aligned in parallel along a predetermined direction shifted at a fixed angle (e.g., approximately 15° clockwise) from the vertical or longitudinal direction of FIG. 3 when no electric field is applied, as shown by the arrow in FIG. 3. This means that the initial alignment direction of the liquid crystal molecules **21** is defined at the direction indicated by the arrow in FIG. 3. Moreover, the transmission axes of the pair of polarizer plates are crossed at right angles. The transmission axis of one of the pair of polarizer plates is in accordance with the alignment direction of the liquid crystal molecules **21** when no electric field is applied (i.e., the initial alignment direction).

#### Fabrication Method of First Embodiment

Next, a fabrication method of the LCD device according to the first exemplary embodiment shown in FIGS. 3 to 5 will be explained below.

The first substrate (active-matrix substrate) **11** is fabricated in the following way.

First, a Cr film is formed on the whole surface of the glass plate **11a** and patterned to have a predetermined shape, thereby forming the gate electrodes, the gate bus lines **55**, the common bus lines **52**, and the light-shielding electrodes **53** on the surface of the glass plate **11a**. The gate electrodes are formed in such a way as to be united with the corresponding gate bus lines **55**. Next, the gate insulating film **57**, which is made of  $\text{SiN}_x$ , is formed on the whole surface of the glass plate **11a** to cover the gate electrodes, the gate bus lines **55**, the common bus lines **52**, and the light-shielding electrodes **53**.

Subsequently, an a-Si film is formed on the gate insulating film **57** and patterned to result in island-like parts, thereby forming the semiconductor films **43** for the TFTs **45**. Each of the island-shaped semiconductor films **43** is placed at a position overlapping with a corresponding one of the gate bus lines **55** in such a way that the gate insulating film **57** intervenes between them. Moreover, a Cr film is formed on the gate insulating film **57** and patterned, thereby forming the drain bus lines **56**, the drain electrodes **56a**, and the source electrodes **42** on the gate insulating film **57**. The drain electrodes **56a** are formed in such a way as to be united with the corresponding drain bus lines **56**. Thereafter, the protective insulating film **59**, which is made of  $\text{SiN}_x$ , is formed over the whole surface of the glass plate **11a**, thereby covering the drain bus lines **56**, the drain electrodes **56a**, and the source electrodes **42**.

Following this, the protective insulating film **59** is selectively removed at the predetermined positions superposed on the respective source electrodes **42**, thereby forming the contact holes **61** that reach the corresponding source electrodes **42**. Moreover, the protective insulating film **59** and the gate insulating film **57** are selectively removed at the predetermined positions superposed on the respective common bus lines **52**, thereby forming the contact holes **62** that reach the corresponding common bus lines **52**.

Subsequently, a transparent conductive film, which is made of ITO or the like, is formed on the protective insulating film **59** and patterned to have a predetermined shape, thereby forming the pixel electrodes **71** each having the comb-tooth-like parts **71a** and the common electrodes **72** each having the comb-tooth-like parts **72a** on the protective insulating film **59**. At this time, the pixel electrodes **71** are electrically connected to the corresponding source electrodes **42** by way of the corresponding contact holes **61**. The common electrodes **72** are electrically connected to the corresponding common bus lines **52** by way of the corresponding contact holes **62**. In this way, the first substrate **11** is fabricated.

The second substrate (opposite substrate) **12** is fabricated in the following way.

First, the black matrix layer **81** and the color layer **82** each having the predetermined shape or pattern are formed on the surface of the glass plate **12a**. When the color layer **82** is formed, the red color sublayer **82R**, the green color sublayer **82G**, and the blue color sublayer **82B** each having a predetermined shape are successively formed on the surface of the glass plate **12a** in an appropriate order. Next, the overcoat film **85** is formed over the whole surface of the glass plate **12a**, covering the black matrix layer **81** and the color layer **82**. Thereafter, the columnar spacers (not shown) are formed on the overcoat film **85**. In this way, the second substrate **12** is fabricated.

Following this, the alignment films **31** and **32**, which are made of polyimide, are respectively formed on the surface of the first substrate **11** and the surface of the second substrate **12** fabricated in the above-described manners. The surfaces of

the alignment films **31** and **32** are respectively subjected to the predetermined aligning treatments uniformly.

Thereafter, the first and second substrates **11** and **12** are superposed on each other to have a predetermined gap, such as  $4.0\ \mu\text{m}$ . Next, in a vacuum chamber (not shown), a predetermined nematic liquid crystal material whose refractive index anisotropy is, for example,  $0.075$  is injected into the space between the substrates **11** and **12** and then, the space is sealed. After the sealing operation of the space is completed, the polarizer plates (not shown) are respectively adhered on the outer surfaces of the substrates **11** and **12**. As a result, the LCD panel is completed.

A predetermined driver LSI and a predetermined backlight unit are mounted on the LCD panel thus fabricated. As a result, the LCD device according to the first embodiment having the structure shown in FIGS. **3** to **5** is completed.

With the lateral electric field type LCD device according to the first embodiment shown in FIGS. **3** to **5**, the liquid crystal driving electric field is uniformly generated along the approximately lateral (horizontal) direction of FIG. **3** when voltages are applied. For this reason, the alignment state of the liquid crystal molecules **21** existing in the liquid crystal layer **20**, which have been aligned along the initial alignment direction (i.e., the direction indicated by the arrow in FIG. **3**) when no voltage is applied, is changed by the applied liquid crystal driving electric field in such a way that the liquid crystal molecules **21** are rotated clockwise in planes approximately parallel to the first and second substrate **11** and **12**. Since the transmittances in the respective pixel regions P (i.e., the respective pixels) are modulated by this alignment state change of the liquid crystal molecules **21**, images can be displayed as desired.

Moreover, with the lateral electric field type LCD device according to the first embodiment, both of the pixel electrodes **71** and the common electrodes **72** for generating the liquid crystal driving electric field are made of transparent conductive material and therefore, light penetrates through the regions where the pixel and common electrodes **71** and **72** are present. For this reason, the aperture ratio and the transmittance are improved compared with the case where the pixel electrodes **71** and the common electrodes **72** are made of an opaque metal or metals.

In addition, since the amount of the opaque metallic parts existing in the openings of the black matrix layer **81** is reduced in the above-described manner, the scattering of light caused by the edges of the opaque metallic parts and the alignment distortion of the liquid crystal molecules **21** caused by the level differences in the vicinities of the same edges are suppressed. The scattering of light and the alignment distortion of the liquid crystal molecules **21** will be causes of optical leakage when black is displayed. However, with the lateral electric field type LCD device of the first embodiment, the scattering of light and the alignment distortion of the liquid crystal molecules **21** are suppressed and therefore, the display contrast is improved.

If the opaque metallic parts are present in the openings of the black matrix layer **81**, the incident light will be reflected by these opaque metallic parts when this LCD device is used in a comparatively well-lighted place, and as a result, the "light place contrast" is likely to deteriorate conspicuously. However, the LCD device of the first embodiment does not include such the opaque metallic parts in the openings of the black matrix layer **81**. Accordingly, the light place contrast of this device is prevented from deteriorating.

Furthermore, the two light-shielding electrodes **53** are respectively provided in the vicinities of the two drain bus lines **56** that define the pixel region P. The areas between the

light-shielding electrodes **53** and the corresponding drain bus lines **56** adjacent thereto are covered with the black matrix layer **81** placed on the second substrate **12**. Therefore, the leakage of light and the vertical cross talk induced by the leaked electric field from the respective drain bus lines **56** are restrained.

These points or advantages are the same as those of the above-described related-art LCD device shown in FIGS. **1** and **2**. However, the LCD device according to the first embodiment of the invention is different from the related-art LCD device in that the two light-shielding electrodes **53** provided in each of the pixel regions **P** are not electrically connected to any other electrodes and any bus lines existing in their vicinities, in other words, the electrodes **53** are electrically isolated.

Specifically, similar to the above-described related-art LCD device, the two light-shielding electrodes **53** are adjacent to the drain bus lines **56** that define the pixel region **P**, and are extended along the same drain bus lines **56**. However, the light-shielding electrodes **53** are electrically isolated from their neighboring electrodes and bus lines and are overlapped with the adjoining comb-tooth-shaped parts **71a** of the pixel electrode **71** corresponding to the pixel region **P**. Therefore, in the operating state, the light-shielding electrodes **53** will be electrically floating. In this state, the electric potentials of the light-shielding electrodes **53** will be close to the electric potential of the pixel electrode **71** (which is equivalent to the signal voltage applied). This is because the isolated light-shielding electrodes **53** are overlapped with the comb-tooth-like parts **71a** of the pixel electrode **71** that extend along the drain bus lines **56** in their vicinities in such a way that the gate insulating film **57** intervenes between them. For this reason, the electric potential differences between the drain bus lines **56** and the corresponding light-shielding electrodes **53** are very small, in other words, the coupling or parasitic capacitances between the drain bus lines **56** and the corresponding light-shielding electrodes **53** are very small.

On the other hand, with the related-art LCD device shown in FIGS. **1** and **2**, the light-shielding parts **152a** are united with the corresponding common bus line **152** and therefore, the electric potential of the light-shielding parts **152a** will be equal to that of the corresponding common electrode **172**. Therefore, the electric potential difference between the drain bus line **156** and its corresponding common bus line **152** will be equal to the difference between the electric potential equivalent to the signal voltage supplied to the drain bus line **156** and the electric potential of the common electrode **172**. This means that the coupling or parasitic capacitance between the drain bus line **156** and its corresponding light-shielding parts **152a** will be considerably large.

As explained above, with the LCD device of the first embodiment, the coupling or parasitic capacitances between the drain bus lines **56** and their corresponding light-shielding electrodes **53** are smaller than the coupling or parasitic capacitance between the drain bus line **156** and the corresponding common bus line **152** (i.e., the corresponding light-shielding parts **152a**) of the related-art LCD device, and as a result, the lateral cross talk is suppressed. Moreover, because of the suppression of the lateral cross talk, the image quality is improved.

In addition, the two light-shielding electrode **53** arranged along the respective drain bus lines **56** in each of the pixel regions **P** will be electrically floating in the operating state; however, the light-shielding electrodes **53** are respectively overlapped with the two outer comb-tooth-like parts **71a** of the corresponding pixel electrode **71** in such a way that the gate insulating film **57** intervenes between them. Therefore,

the electric potentials of the light-shielding electrodes **53** in the operating state will be close to the electric potential of the corresponding pixel electrode **71**. As a result, an electric field that changes strongly the alignment state of the liquid crystal molecules **21** from their initial alignment direction does not arise between the two outer comb-tooth-like parts **71a** and the light-shielding electrodes **53**. This means that stable display is realized.

#### Structure of Second Embodiment

FIGS. **6** and **7**, and FIGS. **8A** to **8D** show the structure of a lateral electric field (IPS) type active-matrix addressing LCD device according to a second exemplary embodiment of the present invention. FIG. **6** is a partial plan view of the active-matrix substrate used in this LCD device. FIG. **7** is an explanatory partial plan view showing the plan shapes of the pixel electrode and the common electrode used in this LCD device. FIGS. **8A** to **8D** are explanatory plan views showing the plan shapes of the common bus line, the source electrode, and the auxiliary electrode used in this LCD device, respectively. These figures show the structure of one of the pixel regions.

The structure of the LCD device according to the second embodiment resembles that of the LCD device according to the first embodiment shown in FIGS. **3** to **5** at many points. However, the former is different from the latter in that the pixel electrodes **71** and the common electrodes **72** for generating lateral electric field, and the drain lines **56** are bent at their middle positions to have approximately V-shaped patterns, thereby intentionally making the liquid crystal driving (rotating) directions different from each other at each side of their bent positions in the operating state. Moreover, the plan shapes of the pixel electrodes **71**, the common electrodes **72**, and the source electrodes **42** are somewhat different from each other.

Accordingly, the explanation about the same or common structural components will be omitted here by attaching the same reference numerals as used in the above-described first embodiment to these components, and these structural differences will be mainly explained below.

The first substrate (i.e., the active-matrix substrate) **11** of the LCD device according to the second embodiment comprises gate bus lines **55** extended along the lateral (horizontal) direction of FIG. **6** and arranged at equal intervals along the longitudinal (vertical) direction thereof, and drain bus lines **56** extended along the longitudinal direction of FIG. **6** and arranged at equal intervals along the lateral direction thereof. A pixel region **P** is formed in each of the approximately rectangular regions defined by the gate bus lines **55** and the drain bus lines **56**. These pixel regions **P** are arranged in a matrix array as a whole.

The plan shape of the gate bus lines **55** is the same as that of the first embodiment. The plan shape of the drain bus lines **56** is different from that of the first embodiment. Specifically, the drain bus lines **56** are bent at their middle positions to have approximately V-shaped patterns in each of the pixel regions **P**, thereby dividing the pixel region **P** into a first subregion **1** located above in FIG. **6** and a second subregion **2** located below in the same figure. The inclination direction of the drain bus lines **56** in the first subregion **1** is clockwise with respect to the longitudinal (vertical) direction of FIG. **7** while the inclination direction of the drain bus lines **56** in the second subregion **2** is counterclockwise. The inclination angle in the first subregion **1** is equal in magnitude to that in the second subregion **2**.

Furthermore, the LCD device according to the second embodiment comprises common bus lines **52a** and **52b** extending in parallel to the respective gate bus lines **55**. Each of the common bus lines **52a** is located near the corresponding gate bus line **55** at a predetermined distance, which is adjacent to the bottom of the pixel region P. Each of the common bus lines **52b** is located apart from the corresponding common bus line **52a** and the corresponding gate bus line **55** along the longitudinal direction of FIG. 6, which is adjacent to the top of the pixel region P.

As shown in FIG. 6, the common bus line **52a**, which is located at a lower position in FIG. 6, is extended in parallel to the corresponding gate bus line **55** located at a lower position. Since the common bus line **52a** is slightly shifted upward from the corresponding gate bus line **55**, the common bus line **52a** is placed near the same gate bus line **55**. Similarly, the common bus line **52b**, which is located at an upper position in FIG. 6, is extended in parallel to the corresponding gate bus line **55**. Since the common bus line **52b** is largely shifted upward from the corresponding gate bus line **55** toward the gate bus line **55** for the next upper pixel region P, the common bus line **52b** is placed near the same gate bus line **55**. The common bus line **52a** and **52b** are provided for electrical interconnection among the common electrodes **72** arranged in the respective pixel regions P.

The common bus line **52a**, which has a plan shape shown in FIG. 8A, comprises a relatively wider part (i.e., a widened part) whose inner (upper) edge is sawtooth-shaped for each of the pixel regions P. Similar to the common bus line **52a**, the common bus line **52b**, which has a plan shape shown in FIG. 8C, comprises a relatively wider part (i.e., a widened part) whose inner (lower) edge is sawtooth-shaped for each of the pixel regions P. The plan shapes of the common bus lines **52a** and **52b** are slightly different from each other in accordance with the structures in which the common bus lines **52a** and **52b** are placed.

The gate bus lines **55**, the drain bus lines **56**, and the common bus lines **52a** and **52b** are made of opaque metallic materials, respectively.

In each of the pixel regions P, two belt-shaped (or stripe-shaped) light-shielding electrodes **53** extending respectively along the two drain bus lines **56** that define the pixel region P are provided. The light-shielding electrodes **53** are bent at their middle positions to have approximately V-shaped patterns, similar to the drain bus lines **56**. Moreover, the light-shielding electrodes **53** are not electrically connected to any other electrodes and any bus lines provided near the same electrodes **53**, and are electrically isolated. The light-shielding electrodes **53** have the same plan shape (pattern) as each other. The upper half of each light-shielding electrode **53** with respect to its bent middle position belongs to the first subregion 1 while the lower half thereof belongs to the second subregion 2.

As shown in FIG. 6, the light-shielding electrode **53** positioned at the left side of the pixel region P is adjacent to the right edge of the drain bus line **56** (which is bent V-shaped) placed at the left side of the pixel region P. This light-shielding electrode **53** is extended in parallel to this drain bus line **56** and is apart from the same at a predetermined interval. This light-shielding electrode **53** is not intersected with the corresponding common bus lines **52a** and **52b** and the corresponding gate bus line **55** to the pixel region P.

The light-shielding electrode **53** positioned at the right side of the pixel region P is adjacent to the left edge of the drain bus line **56** (which is bent V-shaped) placed at the right side of the pixel region P. This light-shielding electrode **53** is extended in parallel to this drain bus line **56** and is apart from

the same at a predetermined interval. This light-shielding electrode **53** is not intersected with the corresponding common bus lines **52a** and **52b** and the corresponding gate bus line **55** to the pixel region P.

For each of the pixel regions P, a TFT **45** is formed near the intersection of the corresponding gate bus line **55** and the corresponding drain bus line **56**. The TFT **45** comprises a gate electrode (not shown) united with the corresponding gate bus line **55**; an island-shaped semiconductor film **43** overlapped with the gate electrode in such a way that a gate insulating film **57** intervenes between them; a drain electrode **56a** united with the corresponding drain bus line **56** and overlapped with the semiconductor film **43**; and a source electrode **42** formed to be opposite to the drain electrode **56a** at a predetermined distance and overlapped with the semiconductor film **43**.

The source electrode **42**, which has a plan shape shown in FIG. 8B, is larger than that of the first embodiment. The source electrode **42** is enlarged to such a level as to be overlapped with the corresponding common bus line **52a**. The inner (upper) edge of the source electrode **42** is sawtooth-shaped.

At the position overlapping with the common bus line **52b** in each of the pixel regions P, an auxiliary electrode **46** having a similar plan shape to the source electrode **42** is formed. The auxiliary electrode **46** is placed on the same layer as the source electrode **42** and is made of the same material as the source electrode **42**. The auxiliary electrode **46** has a plan shape shown in FIG. 8D. Similar to the source electrode **42**, the inner (lower) edge of the auxiliary electrode **46** is sawtooth-shaped. The plan shapes of the source electrode **42** and the auxiliary electrode **46** are slightly different from each other in accordance with the structures in which the source electrode **42** and the auxiliary electrode **46** are placed. The auxiliary electrode **46** is electrically connected to a base **71c** of a corresponding pixel electrode **71** explained later by way of a corresponding one of contact holes **63**.

In each of the pixel regions P, a pixel electrode **71** and a common electrode **72** for generating liquid crystal driving electric field are formed, as shown in FIGS. 6 and 7. The pixel electrode **71** and the common electrode **72**, each of which is made of a transparent conductive material and is comb-tooth-shaped, are bent to have approximately V-like plan shapes similar to the drain bus lines **56**.

As shown in FIG. 7, the pixel electrode **71** comprises a belt-shaped base **71b** placed on the side of the TFT **45** in the pixel region P, a belt-shaped base **71c** placed on the opposite side to the TFT **45** in the pixel region P, three approximately V-shaped, comb-tooth-like parts **71a** protruding from the base **71b** toward the opposite side to the TFT **45** (toward the upper side in FIG. 7) in the pixel region P, and an approximately V-shaped, comb-tooth-like part **71a** protruding from the base **71c** toward the side of the TFT **45** (toward the lower side in FIG. 7) in the pixel region P. The base **71c** is joined to the top of one of the three comb-tooth-like parts **71a** protruding from the base **71b** located at the right side of the pixel region P. The base **71b** is not overlapped with the corresponding gate bus line **55** but is overlapped with the source electrode **42** of the corresponding TFT **45**. All of the four comb-tooth-like parts **71a** are extended in parallel to the V-shaped drain bus lines **56** that define the pixel region P, and are arranged along the bases **71b** and **71c** (along the lateral direction in FIG. 7) at equal intervals. The top ends of the respective comb-tooth-like parts **71a** protruding from the base **71b** are located near the corresponding common bus line **52b**. The top end of the comb-tooth-like part **71a** protruding from the base **71c** is located near the corresponding common bus line **52a**. Two of the comb-tooth-like parts **71a** placed at outer

positions of the pixel electrode **71** are respectively overlapped with the two corresponding light-shielding electrodes **53** existing near the two drain bus lines **56** that define the pixel region P. The comb-tooth-like parts **71a** are somewhat narrower in width than the light-shielding electrodes **53**. The pixel electrode **71** is electrically connected to the source electrode **42** of the corresponding TFT **45** at the base **71b** by way of a corresponding one of contact holes **61**.

The common electrode **72** comprises an approximately L-shaped base **72b** placed on the opposite side to the TFT **45** in the pixel region P, an approximately L-shaped base **72c** placed on the side of the TFT **45** in the pixel region P, two comb-tooth-like parts **72a** protruding from the base **72b** toward the side of the TFT **45** (toward the lower side in FIG. 7), and a comb-tooth-like part **72a** protruding from the base **72c** toward the opposite side to the TFT **45** (toward the upper side in FIG. 7). The base **72b** is entirely overlapped with the corresponding common bus line **52b**. The base **72c** is overlapped with the corresponding common bus line **52a** and the corresponding gate bus line **55**. All of the three comb-tooth-like parts **72a** are extended in parallel to the two drain bus lines **56** that define the pixel region P, and are arranged along the bases **72b** and **72c** (along the lateral direction in FIG. 7) at equal intervals. Accordingly, the comb-tooth-like parts **72a** are parallel to the comb-tooth-like parts **71a** of the pixel electrode **71** and the drain bus lines **56**. The top ends of the respective comb-tooth-like parts **72a** are located near the base **71b** of the pixel electrode **71**. The three comb-tooth-like parts **72a** and the four comb-tooth-like parts **71a** are arranged alternately along the gate and common bus lines **55** and **52a** and **52b**. Therefore, it may be said that these comb-tooth-like parts **72a** and **71a** are mated with each other. The common electrode **72** is electrically connected to the corresponding common bus line **52b** at the base **72b** by way of a corresponding one of contact holes **62** and at the same time, is electrically connected to the corresponding common bus line **52a** at the base **72c** by way of a corresponding one of contact holes **64**. In addition, as seen from FIG. 7, the bases **72b** and **72c** are joined to each other at the boundary between the two adjoining pixel regions P along the vertical direction of FIG. 7.

The source electrode **42** and the auxiliary electrode **46**, both of which are electrically connected to the pixel electrode **71** and whose electric potentials will be equal to that of the pixel electrode **71**, have the saw-tooth-like parts, respectively. Moreover, the common bus lines **52a** and **52b**, which are electrically connected to the common electrode **72** and whose electric potential will be equal to that of the common electrode **72**, have the saw-tooth-like parts, respectively. The saw-tooth-like parts of the source electrode **42** and the auxiliary electrode **46** and those of the common bus lines **52a** and **52b** are alternately arranged along the gate bus lines **55** (along the lateral direction in FIG. 7). This is to rotate uniformly the liquid crystal molecules **21** along the opposite directions to each other in the first and second subregions **1** and **2**. By using such the structure, the rotation directions of the liquid crystal molecules **21** near the top ends of the comb-tooth-like parts **71a** of the pixel electrode **71** and the top ends of the comb-tooth-like parts **72a** of the common electrode **72** can be approximately equalized to the rotation direction of the liquid crystal molecules **21** in the remaining regions in each of the first and second subregions **1** and **2**.

The LCD device according to the second embodiment comprises the first substrate (an active-matrix substrate) **11** having the structure of FIG. 6, a second substrate (an opposite substrate) **12**, and a liquid crystal layer **20**, similar to the LCD device according to the first embodiment. However, the structures of the second substrate **12** and the liquid crystal layer **20**

are the same as those used in the first embodiment. Therefore, the explanation about the structures of the second substrate **12** and the liquid crystal layer **20** are omitted here, and only the structure of the first substrate **11** according to the second embodiment will be explained below.

Since the cross-sectional structure of the LCD device according to the second embodiment along the V-V line in FIG. 3 is the same as that of the LCD device according to the above-described first embodiment, FIG. 5 will be referred to in the following explanation as necessary.

The gate bus lines **55**, the common bus lines **52a** and **52b**, the light-shielding electrodes **53**, and the gate electrodes of the TFTs **45** are formed on the surface of the glass plate **11a** of the first substrate **11**. The gate insulating film **57** is formed on the surface of the glass plate **11a** to cover the gate bus lines **55**, the common bus lines **52a** and **52b**, the light-shielding electrodes **53**, and the gate electrodes. (Only the light-shielding electrodes **53** are shown in FIG. 5.) The gate electrodes are united with the corresponding gate bus lines **55**. The drain bus lines **56**, the semiconductor films **43** of the TFTs **45**, the drain electrodes **56a**, the source electrodes **42**, and the auxiliary electrodes **46** are formed on the gate insulating film **57**. (Only the drain bus lines **56** are shown in FIG. 5.) A protective insulating film **59** is formed on the gate insulating film **57** to cover the drain bus lines **56**, the semiconductor films **43**, the drain electrodes **56a**, the source electrodes **42**, and the auxiliary electrodes **46**. The pixel electrodes **71** and the common electrodes **72** are formed on the protective insulating film **59**. (Only the comb-tooth-like parts **71a** of the pixel electrodes **71** and the comb-tooth-like parts **72a** of the common electrodes **72** are shown in FIG. 5.) In this way, the common bus lines **52a** and **52b** are placed on the surface of the glass plate **11a**, and the drain bus lines **56** are placed on the gate insulating film **57**; therefore, the common bus lines **52a** and **52b** are placed on a lower layer than the drain bus lines **56** (in other words, on a further layer from the liquid crystal layer **20** than the drain bus lines **56**). Similarly, since the gate bus lines **55** are placed on the surface of the glass plate **11a**, the gate bus lines **55** also are placed on a lower layer than the drain bus lines **56** (in other words, on a further layer from the liquid crystal layer **20** than the drain bus lines **56**). The pixel electrodes **71** and the common electrodes **72** are placed on the protective insulating film **59** and therefore, the pixel and common electrodes **71** and **72** are placed on an upper layer than the drain bus lines **56** (in other words, on a nearer layer to the liquid crystal layer **20** than the drain bus lines **56**).

On the surface (i.e., the inner face) of the first substrate **11** having the above-described structure, in other words, on the protective insulating film **59**, an alignment film **31** made of an organic polymer is formed. Therefore, the pixel electrodes **71** and the common electrodes **72** are covered with the alignment film **31**. The surface of the alignment film **31** is subjected to a predetermined aligning treatment.

Because the surfaces of the alignment films **31** and **32** are respectively subjected to the predetermined aligning treatments, as shown by the arrow in FIG. 6, the liquid crystal molecules **21** in the liquid crystal layer **20** are aligned in parallel along the longitudinal (vertical) direction of FIG. 6 when no electric field is applied. This means that the initial alignment direction of the liquid crystal molecules **21** is defined at the direction indicated by the arrow in FIG. 6.

#### Fabrication Method of Second Embodiment

Next, a fabrication method of the LCD device according to the second exemplary embodiment shown in FIGS. 6 to 8 will be explained below.

First, a Cr film is formed on the whole surface of the glass plate **11a** of the first substrate **11** and patterned to have a predetermined shape, thereby forming the gate electrodes, the gate bus lines **55**, the common bus lines **52a** and **52b**, and the light-shielding electrodes **53** on the surface of the glass plate **11a**. Next, the gate insulating film **57** made of  $\text{SiN}_x$  is formed on the whole surface of the glass plate **11a** to cover the gate electrodes, the gate bus lines **55**, the common bus lines **52a** and **52b**, and the light-shielding electrodes **53**.

Subsequently, an a-Si film is formed on the gate insulating film **57** and patterned to result in island-like parts, thereby forming the island-shaped semiconductor films **43** for the TFTs **45**. Each of the island-shaped semiconductor films **43** is placed at a position overlapping with a corresponding one of the gate electrodes in such a way that the gate insulating film **57** intervenes between them. Moreover, a Cr film is formed on the gate insulating film **57** and patterned, thereby forming the drain bus lines **56**, the drain electrodes **56a**, the source electrodes **42**, and the auxiliary electrodes **46** on the gate insulating film **57**. Thereafter, the protective insulating film **59** made of  $\text{SiN}_x$  is formed over the whole surface of the glass plate **11a**, thereby covering the drain bus lines **56**, the drain electrodes **56a**, the source electrodes **42**, and the auxiliary electrodes **46**.

Following this, the protective insulating film **59** is selectively removed at the predetermined positions superposed on the respective source electrodes **42** and the respective auxiliary electrodes **46**, thereby forming the contact holes **61** that reach the source electrodes **42** and the contact holes **65** that reach the auxiliary electrodes **46**. Moreover, the protective insulating film **59** and the gate insulating film **57** are selectively removed at the predetermined positions superposed on the respective common bus lines **52a** and **52b**, thereby forming the contact holes **63** that reach the common bus lines **52b** and the contact holes **64** that reach the common bus lines **52a**.

Subsequently, a transparent conductive film made of ITO or the like is formed on the protective insulating film **59** and patterned to have a predetermined shape, thereby forming the pixel electrodes **71** having the comb-tooth-like parts **71a** and the common electrode **72** having the comb-tooth-like parts **72a** on the protective insulating film **59**. At this time, the pixel electrodes **71** are electrically connected to the corresponding source electrodes **42** and the auxiliary electrodes **46** by way of the corresponding contact holes **61** and **65**, respectively. The common electrodes **72** are electrically connected to the corresponding common bus lines **52b** and **52a** by way of the corresponding contact holes **63** and **64**, respectively. In this way, the first substrate **11** is fabricated.

The second substrate **12** is fabricated in the same way as the above-described first embodiment.

Then, the LCD panel is formed in the same way as the first embodiment using the first and second substrates **11** and **12** thus fabricated, and a predetermined driver LSI and a predetermined backlight unit are mounted on this LCD panel. As a result, the LCD device according to the second embodiment having the structure shown in FIGS. **6** to **8** is completed.

As explained above, the lateral electric field type LCD device according to the second embodiment comprises the structure that the light-shielding electrodes **53** are respectively provided near the drain bus lines **56** in such a way as to be electrically isolated from any other electrodes and any bus lines in the neighborhood of the light-shielding electrodes **53**, which is the same as the LCD device according to the first embodiment. Accordingly, it is apparent that the LCD device according to the second embodiment has the same advantages as those of the first embodiment.

However, with the lateral electric field type LCD device of the second embodiment, the direction of the liquid crystal driving electric field generated by the applied voltage is slightly inclined clockwise with respect to the lateral direction of FIG. **6** in the first subregion **1**, and it is slightly inclined counterclockwise with respect to the lateral direction in the second subregion **2**. Therefore, the liquid crystal molecules **21**, which are initially aligned along the longitudinal direction of FIG. **6** uniformly when no electric field is applied, are rotated clockwise in the first subregion **1** and counterclockwise in the second subregion **2** by the liquid crystal driving electric field applied. In this way, the rotation directions of the liquid crystal molecules **21** in the first and second subregions **1** and **2** are opposite to each other and as a result, an additional advantage that the display coloring due to the change of the viewing angle can be restrained arises.

Moreover, with the lateral electric field type LCD device of the second embodiment, the common electrodes **72** provided in the respective pixel regions P are connected to each other by the common bus lines **52a** and **52b** along the lateral or horizontal direction of FIG. **6** and at the same time, they are connected to each other by their bases **72b** and **72c** along the longitudinal or vertical direction of the same figure in such a way as to be astride the gate bus lines **55**. This means that the common electrodes **72** have a meshed structure as a whole. Therefore, the common electrodes **72** in the respective pixel regions P are difficult to be affected by the electric potential changes of the drain bus lines **56**. Accordingly, it is more certain to suppress the lateral cross talk than the LCD device of the first embodiment, which results in an additional advantage that the image quality is improved furthermore.

#### Third Embodiment

FIGS. **9** and **10** show the structure of a lateral electric field (IPS) type active-matrix addressing LCD device according to a third exemplary embodiment of the present invention. FIG. **9** is a partial plan view of the active-matrix substrate used in this LCD device. FIG. **10** is an explanatory partial plan view showing the plan shapes of the pixel electrode and the common electrode. These figures show the structure of one of the pixel regions.

The LCD device according to the third embodiment is the same in structure as that of the above-described first embodiment except that the two light-shielding electrodes **53** provided in each of the pixel regions P are electrically connected to each other and that the two light-shielding electrodes **53** are electrically connected to the corresponding pixel electrode **71** (which means that the light-shielding electrodes **53** are not electrically floating). Therefore, the explanation about the same structure is omitted here by attaching the same reference symbols as used in the first embodiment to the same elements.

With the LCD device of the third embodiment, similar to the LCD device of the above-described first embodiment, the two belt-shaped (or stripe-shaped) light-shielding electrodes **53** provided in each pixel region P are respectively extended along the two drain bus lines **56** that define the pixel region P in the vicinities of the same drain bus lines **56**. However, the light-shielding electrodes **53** are not electrically isolated from their neighboring electrodes and bus lines. These two light-shielding electrodes **53** are electrically and mechanically connected to each other with an approximately belt-shaped connecting part **54** formed on the glass plate **11a** near the corresponding TFT **45**. The connecting part **54** is located near the corresponding gate bus line **55** and extended in parallel to the same.

A part of the connecting part **54** is protruded downward in FIG. **9** (i.e., toward the side of the TFT **45**) to overlap with the base **71b** of the corresponding pixel electrode **71**. The connecting part **54** is electrically connected to the pixel electrode **71** at the overlapping position with the base **71b** by way of the corresponding contact hole **66** that penetrates through the gate insulating film **57** and the protective insulating film **59**. The comb-too-like parts **72a** of the common electrode **72** are slightly shortened compared with the first embodiment so as not to overlap with the connecting part **54**.

The connecting parts **54** are formed simultaneously with the formation of the light-shielding electrodes **53** on the surface of the glass plate **11a**. In other words, the light-shielding electrodes **53** and the connecting parts **54** are formed on the surface of the glass plate **11a** by patterning the same metal film (e.g. a Cr film).

As explained above, with the LCD device according to the third embodiment, the two light-shielding electrodes **53** provided in each pixel region P are electrically connected to the base **71b** of the corresponding pixel electrode **71** and therefore, the electric potential of the light-shielding electrodes **53** is always equal to that of the pixel electrode **71**. As explained for the LCD device of the above-described first embodiment, the electric potentials of the electrically floating light-shielding electrodes **53** are close to the electric potential of the corresponding pixel electrode **71**. Thus, almost the same action or function as that of the first embodiment is generated in the structure of the LCD device of the third embodiment also. Accordingly, it is apparent that the LCD device of the third embodiment has the same advantages as those of the first embodiment.

In addition, the two light-shielding electrodes **53** provided in each pixel region P are electrically connected to each other with the belt-shaped connecting part **54** and at the same time, these electrodes **53** are electrically connected to the corresponding pixel electrode **71** by way of the corresponding contact hole **66** in the third embodiment. However, the invention is not limited to this. Each of the two light-shielding electrodes **53** provided in each pixel region P may be directly connected to the corresponding pixel electrode **71** by way of the corresponding contact hole **66** without using the connecting part **54**. It is sufficient for the third embodiment of the invention that the light-shielding electrodes **53** are electrically connected to the corresponding pixel electrode **71** at any position or positions in each pixel region P.

#### Variations

The above-described first to third exemplary embodiments are preferred embodied examples of the present invention. Therefore, it is needless to say that the present invention is not limited to these embodiments and that any other modification is applicable to these embodiments.

For example, the light-shielding electrode **53** is belt-shaped in the above-described first to third embodiments of the invention. However, it is sufficient for the invention that the light-shielding electrode **53** is extended along the corresponding drain bus line **56** and is placed near the same bus line **56**. The light-shielding electrode **53** may have any other shape or pattern than the belt-like one.

While the preferred forms of the present invention have been described, it is to be understood that modifications will be apparent to those skilled in the art without departing from the spirit of the invention. The scope of the present invention, therefore, is to be determined solely by the following claims.

What is claimed is:

**1.** A lateral electric field type active-matrix addressing liquid crystal display device comprising:

a first substrate including gate bus lines, common bus lines parallel to the gate bus lines, and drain bus lines intersected with the gate bus lines and the common bus lines; a second substrate held to be opposite to the first substrate at a predetermined gap;

a liquid crystal layer placed between the first substrate and the second substrate;

pixel regions defined by the gate bus lines and the drain bus lines to be arranged in a matrix array; and

each of the pixel regions including a switching element, a pixel electrode electrically connected to the switching element, and a common electrode electrically connected to a corresponding one of the common bus lines;

wherein in each of the pixel regions, at least one light-shielding layer is formed to extend along the drain bus lines that define the pixel electrode near the same drain bus lines;

the at least one light-shielding layer is electrically isolated and is overlapped with at least one part of the pixel electrode corresponding to the pixel region in such a way that an insulating film intervenes between the at least one light-shielding layer and the at least one part, wherein the at least one part is extended along the drain bus lines in their vicinities;

liquid crystal molecules confined in the liquid crystal layer are rotated in planes approximately parallel to the first substrate, thereby displaying images; and

the electrically isolated light-shielding layer is electrically separated from the gate bus lines, the drain bus lines, the common bus lines, and the switching elements, and is arranged so that, in an operating state, an electric potential of the light-shielding layer is close to an electric potential of the corresponding pixel electrode so that a coupling capacitance between the drain bus lines and the light-shielding layer is very small.

**2.** The device according to claim **1**, wherein the at least one light-shielding layer is placed on a different layer from that for the drain bus lines in such a way that an insulating film intervenes between them.

**3.** The device according to claim **1**, wherein the at least one part of the pixel electrode corresponding to the pixel region is comb-tooth-shaped; and

the at least one light-shielding layer is belt-shaped to extend along the drain bus lines.

**4.** The device according to claim **1**, wherein the pixel electrode corresponding to the pixel region comprises comb-tooth-shaped parts extending along the drain bus lines;

two of the comb-tooth-shaped parts of the pixel electrode located at outer positions are used as the at least one part of the pixel electrode extending along the two drain bus lines that define the pixel electrode in the vicinities of the same drain bus lines; and

27

the two light-shielding layers are belt-shaped to extend along the two drain bus lines that define the pixel electrode, respectively.

5. The device according to claim 1, wherein the drain bus lines are bent to have approximately V-like shapes in accordance with the respective pixel regions; and

the pixel electrodes and the common electrodes are bent to have approximately V-like shapes corresponding to the drain bus lines.

28

6. The device according to claim 1, wherein the pixel electrodes are placed on a different layer from that for the drain bus lines in such a way that an insulating film intervenes between them.

7. The device according to claim 1, wherein the common electrodes are placed on a same layer as the pixel electrodes.

8. The device according to claim 1, wherein the pixel electrodes and/or the common electrodes are made of a transparent conductive material or materials.

\* \* \* \* \*

专利名称(译)	横向电场型有源矩阵寻址液晶显示装置		
公开(公告)号	<a href="#">US8358392</a>	公开(公告)日	2013-01-22
申请号	US12/249465	申请日	2008-10-10
[标]申请(专利权)人(译)	NEC液晶技术株式会社		
申请(专利权)人(译)	NEC液晶技术有限公司.		
当前申请(专利权)人(译)	NLT科技有限公司.		
[标]发明人	SUZUKI TERUAKI NISHIDA SHINICHI		
发明人	SUZUKI, TERUAKI NISHIDA, SHINICHI		
IPC分类号	G02F1/1333 G02F1/1343		
CPC分类号	G02F1/134363 G02F1/136286 G02F1/13439		
代理机构(译)	YOUNG & THOMPSON		
助理审查员(译)	穆尼, MICHAEL		
优先权	2007275702 2007-10-23 JP		
其他公开文献	US20090103035A1		
外部链接	<a href="#">Espacenet</a> <a href="#">USPTO</a>		

### 摘要(译)

横向电场型有源矩阵寻址液晶显示装置以简单的结构抑制由漏极总线与其对应的公共总线之间的耦合电容(即,寄生电容)引起的横向串扰。在每个像素电极中,形成至少一个电隔离的光屏蔽电极,以沿着漏极总线延伸,所述漏极总线在相同的漏极总线附近限定像素电极。遮光电极与像素电极中的相应一个的一部分重叠到像素区域,使得绝缘膜介于遮光电极和部件之间,该部分沿着这些漏极总线延伸。其附近。遮光电极可以在像素区域中的一点处电连接到对应的一个像素电极。

