



US007589801B2

(12) **United States Patent**
Yoon

(10) **Patent No.:** **US 7,589,801 B2**
(45) **Date of Patent:** **Sep. 15, 2009**

(54) **LIQUID CRYSTAL DISPLAY AND METHOD OF MANUFACTURING THEREOF**

2008/0123008 A1* 5/2008 Yoshii 349/44

FOREIGN PATENT DOCUMENTS

- (75) Inventor: **Joo-Sun Yoon**, Seoul (KR)
- (73) Assignee: **Samsung Electronics Co., Ltd.**, Suwon-Si (KR)
- (*) Notice: Subject to any disclaimer, the term of this patent is extended or adjusted under 35 U.S.C. 154(b) by 207 days.

JP	2002-090720	3/2002
JP	2004-258626	9/2004
JP	2005-077475	3/2005
JP	2005-236191	9/2005
KR	1020040009901	1/2004
KR	1020050097580	10/2005
KR	1020060016881	2/2006

OTHER PUBLICATIONS

- (21) Appl. No.: **11/691,111**
- (22) Filed: **Mar. 26, 2007**
- (65) **Prior Publication Data**
US 2007/0291194 A1 Dec. 20, 2007

English Abstract for Japanese Publication No. 2002-090720.
 English Abstract for Japanese Publication No. 2004-258626.
 English Abstract for Japanese Publication No. 2005-077475.
 English Abstract for Japanese Publication No. 2005-236191.
 English Abstract for Korean Publication No. 1020040009901.
 English Abstract for Korean Publication No. 1020050097580.
 English Abstract for Korean Publication No. 1020060016881.

- (30) **Foreign Application Priority Data**
Jun. 15, 2006 (KR) 10-2006-0053853

* cited by examiner

- (51) **Int. Cl.**
G02F 1/135 (2006.01)
G02F 1/136 (2006.01)
G02F 1/1335 (2006.01)

Primary Examiner—Uyen-Chau N Le
Assistant Examiner—Chris Chu
 (74) *Attorney, Agent, or Firm*—F. Chau & Assoc., LLC

- (52) **U.S. Cl.** 349/43; 349/29; 349/44; 349/137
- (58) **Field of Classification Search** 349/29, 349/44, 137
See application file for complete search history.

(57) **ABSTRACT**

A display device includes a thin film transistor (TFT) substrate, a countering substrate facing the TFT substrate, a sealant, and a liquid crystal layer interposed between the TFT substrate and the countering substrate. The TFT substrate includes a substrate having a display area and a peripheral area, a first TFT formed in the peripheral area and including a semiconductor layer and a resistive contact member formed on the semiconductor layer, a light blocking semiconductor pattern, a second TFT formed in the display area and including a gate electrode. The sealant couples the TFT substrate to the countering substrate, and covers the first TFT.

- (56) **References Cited**
U.S. PATENT DOCUMENTS
6,704,068 B2* 3/2004 Murade 349/44
6,879,369 B2 4/2005 Lee et al.
6,897,932 B2* 5/2005 Murade et al. 349/151
2003/0103181 A1* 6/2003 Imayama et al. 349/122

17 Claims, 7 Drawing Sheets

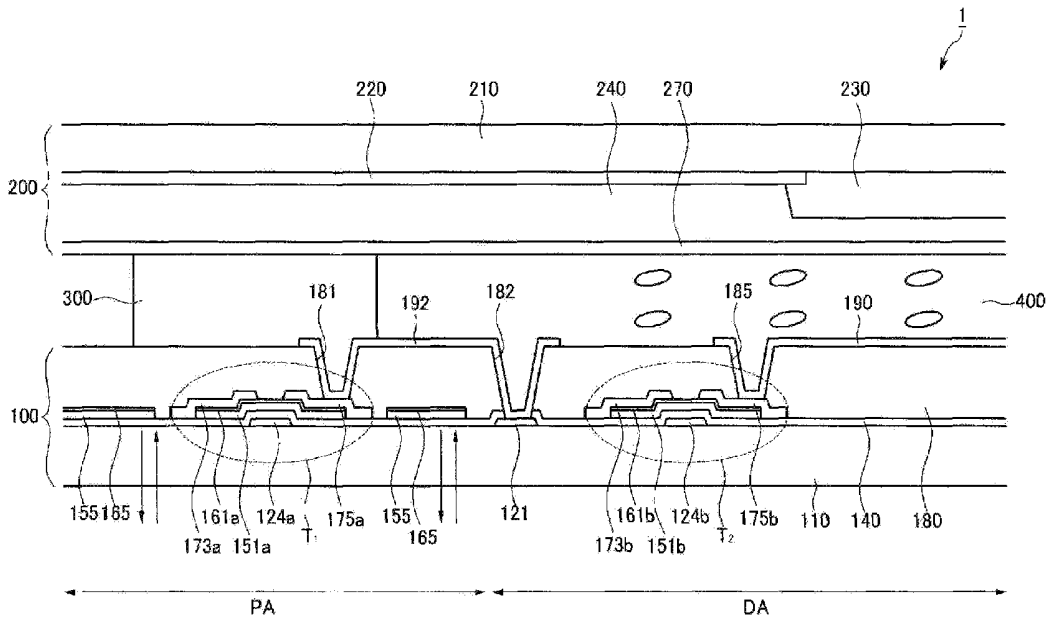

FIG. 1

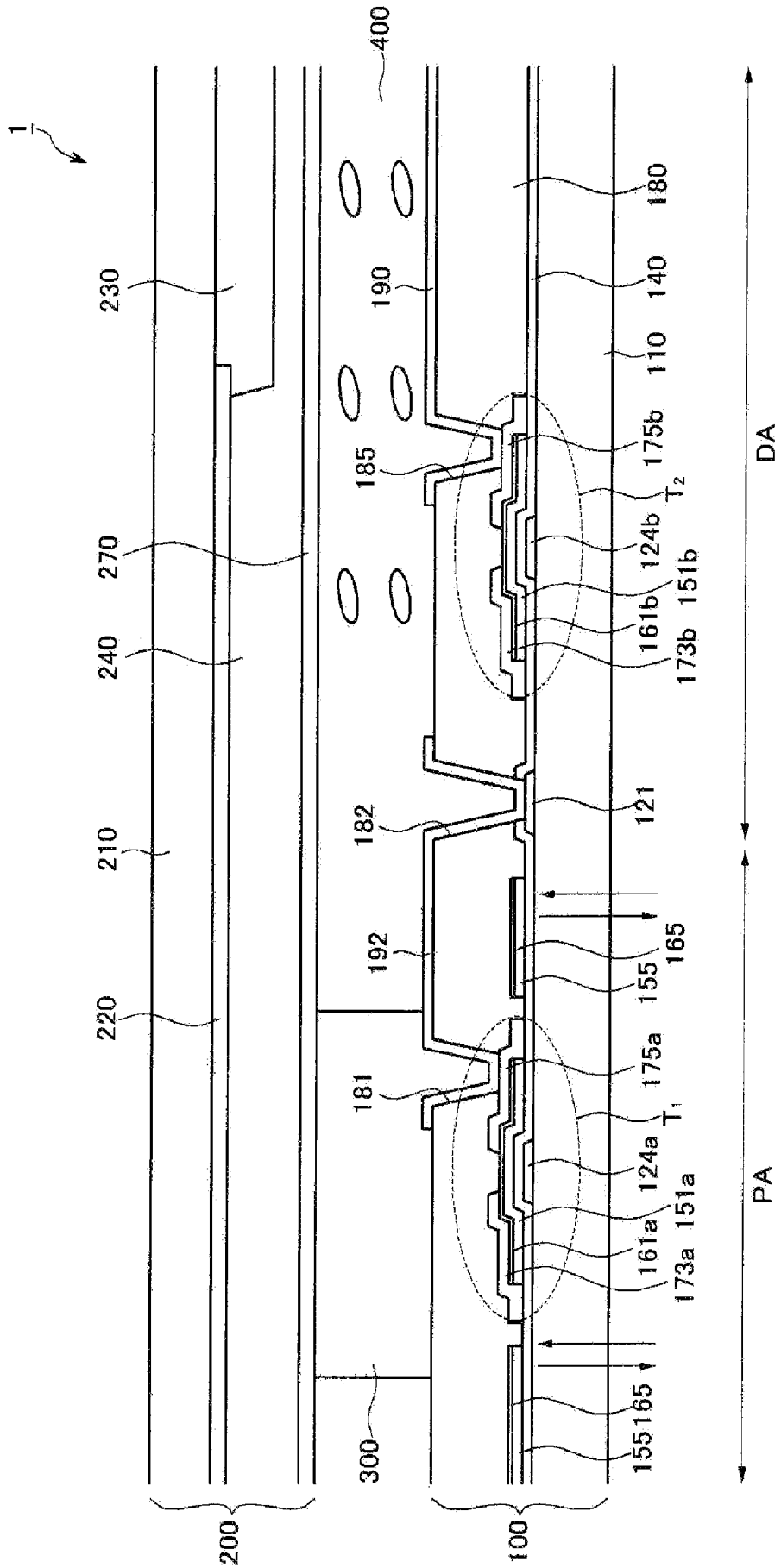

FIG. 2A

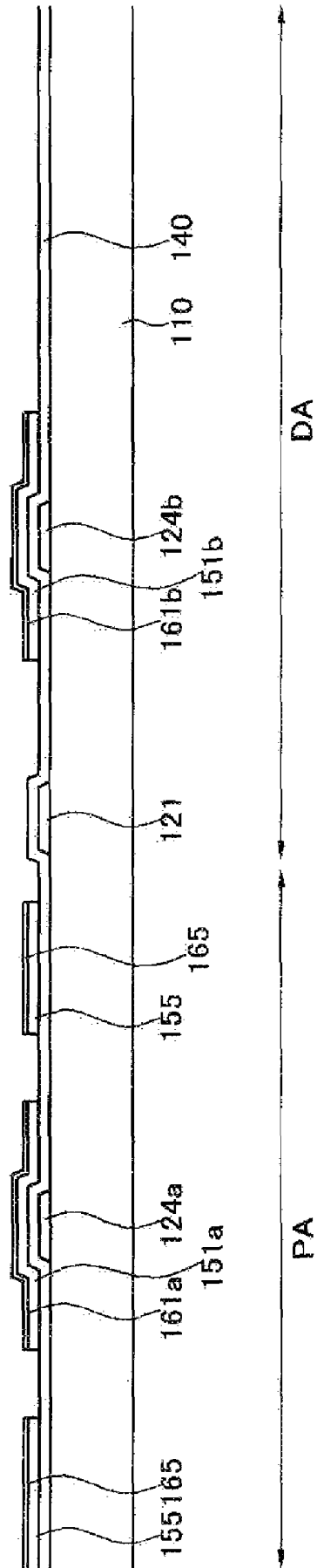

FIG. 2B

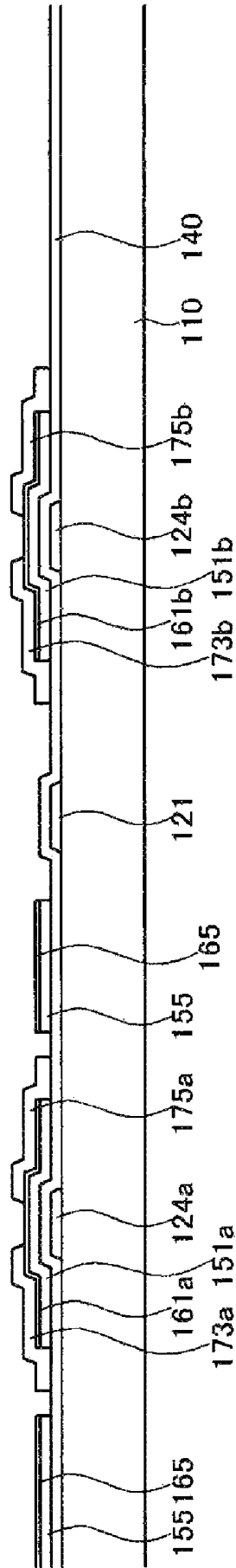

FIG. 2C

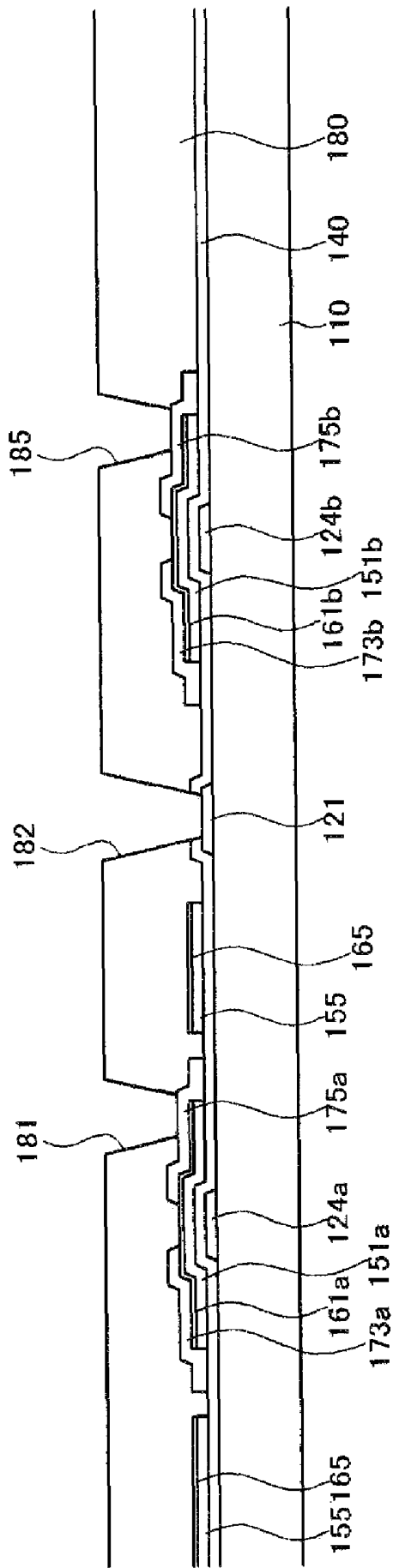

FIG. 2D

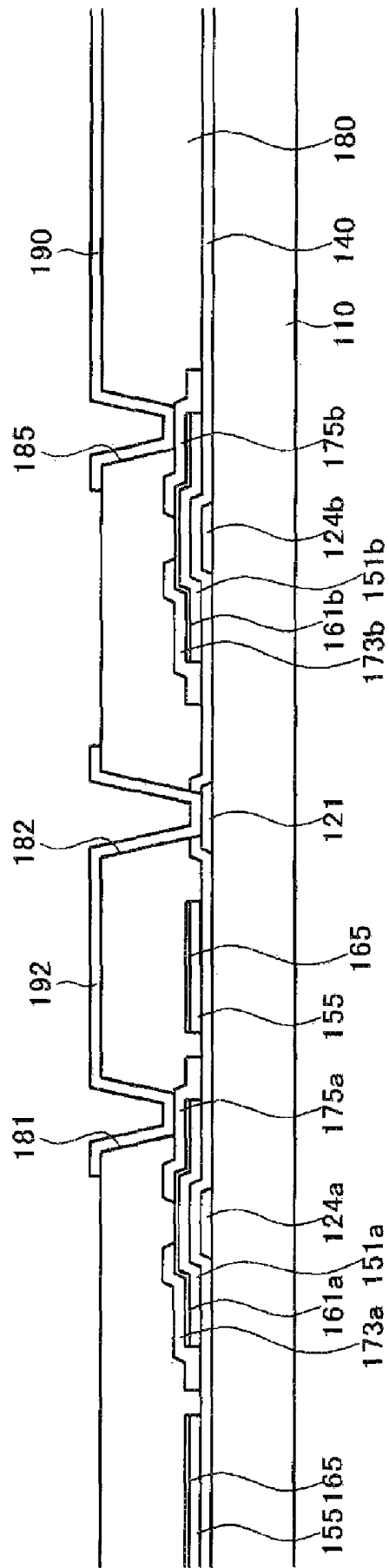
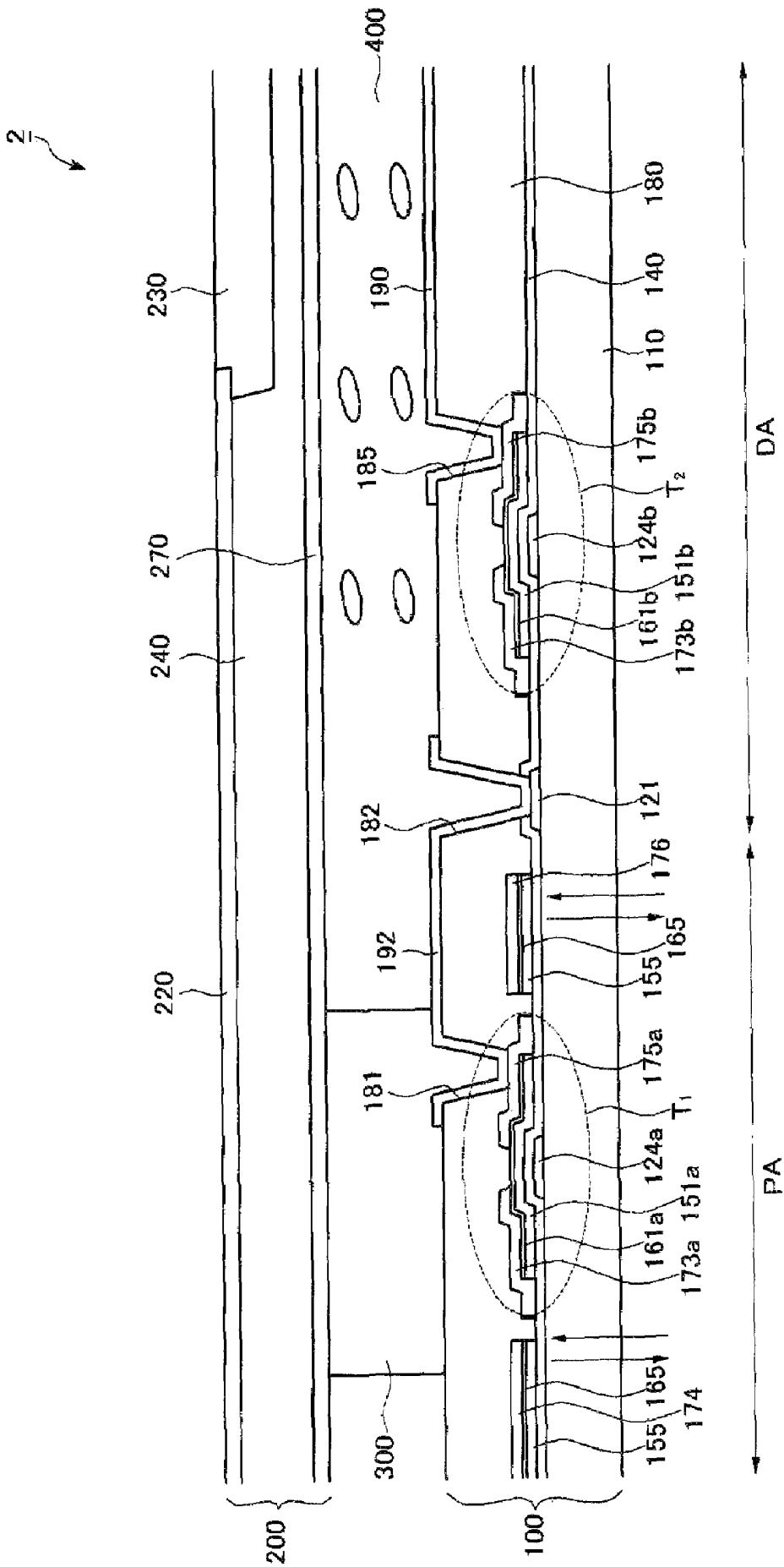

FIG. 3



LIQUID CRYSTAL DISPLAY AND METHOD OF MANUFACTURING THEREOF

CROSS-REFERENCE TO RELATED APPLICATION

The present application claims priority to Korean Patent Application No. 2006-53853, filed on Jun. 15, 2006, the disclosure of which is incorporated herein by reference in its entirety.

BACKGROUND OF THE INVENTION

1. Technical Field

The present disclosure relates to a liquid crystal display and a method of manufacturing the liquid crystal display, and more particularly, to a liquid crystal display having an enhanced display quality.

2. Discussion of the Related Art

A liquid crystal display (LCD) is a commonly used flat panel display. The LCD includes two substrates with electrodes and a liquid crystal layer interposed between the two substrates. By applying voltages to the electrodes and rearranging liquid crystal molecules of the liquid crystal layer, the amount of light transmitted through the two substrates can be adjusted.

The LCD includes a thin film transistor (TFT) substrate having a plurality of pixel electrodes in a matrix in a display area and a countering substrate having a common electrode which is formed on a surface of the countering substrate. Each of the pixel electrodes receives driving voltages so that images are displayed. The TFT substrate includes pixel TFTs connected to each of the pixel electrodes to switch driving voltages applied to the pixel electrodes, a plurality of gate lines transmitting signals to control the pixel TFTs and a plurality of data lines transmitting driving voltages to the pixel electrodes. The pixel TFTs can transmit or block image signals transmitted through the plurality of data lines in response to a gate signal. The gate signal is transmitted through the plurality of gate lines from a gate driver IC disposed in a peripheral area surrounding the display area.

Manufacturing efficiency can be improved by integrating a gate driving circuit including a driving TFT on the TFT substrate. When images are displayed, a portion of light generated from a backlight assembly passes through the peripheral area and is reflected from the countering substrate. Then, the reflected light may impinge upon the driving TFT.

Since the driving TFT is sensitive to light, the reflected light impinging upon the driving TFT may adversely affect the operation of the driving TFT.

SUMMARY OF THE INVENTION

Exemplary embodiments of the present invention provide a liquid crystal display capable of enhancing display quality, and a method of manufacturing the liquid crystal display.

According to an exemplary embodiment of the present invention, a display device includes a thin film transistor (TFT) substrate, a countering substrate facing the TFT substrate, a sealant, and a liquid crystal layer interposed between the TFT substrate and the countering substrate. The TFT substrate may include a substrate having a display area and a peripheral area, a first TFT formed in the peripheral area and having a semiconductor layer and a resistive contact member formed on the semiconductor layer, a light blocking semiconductor pattern, a second TFT formed in the display area and

having a gate electrode. The sealant couples the TFT substrate to the countering substrate, and covers the first TFT.

The display device may further comprise a resistive contact pattern formed on the light blocking semiconductor pattern and can be formed simultaneously with the resistive contact member.

The first TFT may further comprise a source electrode and a drain electrode formed on the semiconductor layer, and a connection part connecting the drain electrode with a gate line. The source electrode and the drain electrode can be spaced apart from the light blocking semiconductor pattern by a predetermined distance. The light blocking semiconductor pattern may have hydrogenated amorphous silicon, and/or crystalline silicon. The sealant may cover at least a portion of the light blocking semiconductor pattern.

According to an exemplary embodiment of the present invention, a method of manufacturing a display device includes forming a thin film transistor (TFT) substrate having a display area and a peripheral area, forming a first gate electrode in the display area and a second gate electrode in the peripheral area, forming a semiconductor layer and a resistive contact member on the first gate electrode and the second gate electrode, forming a first semiconductor layer and a first resistive contact member on the first gate electrode by patterning the resistive contact member and the semiconductor layer, forming a light blocking semiconductor pattern and a resistive contact pattern in the peripheral area, forming a conductive layer on the first resistive contact member, forming a first source electrode and a first drain electrode by patterning the conductive layer, and forming a sealant interposed between the TFT substrate and the countering substrate, wherein the sealant covers the first semiconductor layer.

When the first semiconductor layer and the first resistive contact member are formed, a second semiconductor layer and a second resistive contact member can be formed.

When the first source electrode and the first drain electrode are formed, a second source electrode and a second drain electrode may be formed.

The method of manufacturing the display device may further comprise forming a passivation layer having a first contact hole to expose the first drain electrode and a second contact hole to expose a gate line and forming a connection part connecting the first drain electrode with the gate line.

When the first source electrode and the first drain electrode are formed, the first source electrode and the first drain electrode can be spaced apart from the light blocking semiconductor pattern by a predetermined distance, and a light blocking metal layer may be formed on the light blocking semiconductor pattern. The light blocking metal layer can have substantially the same material as a material of the source electrode and the drain electrode.

The light blocking semiconductor pattern may have hydrogenated amorphous silicon, and/or crystalline silicon. The sealant may cover at least a portion of the light blocking semiconductor pattern.

BRIEF DESCRIPTION OF THE DRAWINGS

Exemplary embodiments of the present invention can be understood in more detail from the following descriptions taken in conjunction with the accompanying drawings, in which:

FIG. 1 is a cross-sectional view showing a display device in accordance with an exemplary embodiment of the present invention;

FIG. 2a to FIG. 2e are cross-sectional views for showing a method of manufacturing a display device in accordance with an exemplary embodiment of the present invention; and

FIG. 3 is a cross-sectional view showing a display device in accordance with an exemplary embodiment of the present invention.

DESCRIPTION OF THE EXEMPLARY EMBODIMENTS

Exemplary embodiments of the present invention will be described below in more detail with reference to the accompanying drawings. The present invention may, however, be embodied in many different forms and should not be construed as limited to the exemplary embodiments set forth herein.

FIG. 1 is a cross-sectional view showing a display device in accordance with an exemplary embodiment of the present invention.

Referring to FIG. 1, a display device 1 includes a thin film transistor (TFT) substrate 100, a countering substrate 200 facing the TFT substrate 100, a sealant 300 interposed between the two substrates 100, 200 and formed along a peripheral area of the two substrates 100, 200, and a liquid crystal layer 400 having liquid crystal molecules, which are injected into an area defined by the sealant 300.

An alignment type of the liquid crystal layer 400 may be twisted nematic, vertical alignment, or electrically controlled birefringence.

Polarizers (not shown) may be attached on outside surfaces of the two substrates 100, 200, respectively. Transmissive axes of the polarizers can be substantially perpendicular to each other.

The TFT substrate 100 includes an insulating substrate 110 having a display area DA to display images and a peripheral area PA surrounding the display area. The insulating substrate 110 may have transparent glass.

The display area DA of the TFT substrate 100 includes a plurality of gate lines 121 and a gate electrode 124b. The peripheral area PA of the TFT substrate 100 includes a gate electrode 124a.

The plurality of gate lines 121 connect to the gate electrode 124b. A gate signal is applied to the gate electrode 124a.

The plurality of gate lines 121 and the gate electrodes 124a, 124b may include, for example, aluminum, an aluminum alloy, silver, a silver alloy, copper, a copper alloy, molybdenum, a molybdenum alloy, chromium, titanium, and/or tantalum. The plurality of gate lines 121 and the gate electrodes 124a, 124b may have a single layer or multiple layers. Each layer of a multiple layer configuration may include a different material. That is, the plurality of gate lines 121 and the gate electrodes 124a, 124b may have, for example, a lower layer (not shown) and an upper layer (not shown). For example, the upper layer of the plurality of gate lines 121 and the gate electrodes 124a, 124b may have a low resistivity metal to reduce signal delay and voltage drop. The upper layer may include, for example, aluminum or an aluminum alloy. The lower layer of the plurality of gate lines 121 and the gate electrodes 124a, 124b may have a material having good contact characteristics with indium tin oxide (ITO), or indium zinc oxide (IZO). The lower layer may include, for example, molybdenum, a molybdenum alloy, and/or chromium. The combination of the multiple layers may have, for example, a lower layer that includes chromium and an upper layer that includes aluminum-neodymium alloy.

A gate insulating layer 140 is formed on the gate lines 121 and the gate electrodes 124a, 124b. The gate insulating layer 140 may have, for example, a silicon nitride (SiNx).

Semiconductor layers 151a, 151b are formed on the gate insulating layer 140, respectively. The semiconductor layers may have, for example, hydrogenated amorphous silicon, and/or crystalline silicon.

A light blocking semiconductor pattern 155 is formed adjacent to the gate electrode 124a in the peripheral area PA and spaced apart from the semiconductor layer 151a. The light blocking semiconductor pattern 155 may have substantially the same material as a material of the semiconductor layer 151a.

The light blocking semiconductor pattern 155 can reflect or absorb light emitted from a backlight assembly disposed behind the TFT substrate 100, so that an amount of light passed through the TFT substrate 100 decreases.

Resistive contact members 161a, 161b are formed on the semiconductor layers 151a, 151b except for channel areas. The resistive contact members 161a, 161b may have, for example, silicide or n+ hydrogenated amorphous silicon doped with high density n-type impurities. The resistive contact members 161a, 161b may be formed between the semiconductor layers 151a, 151b, respectively, and the source and drain electrodes 173a, 173b, 175a, 175b. The resistive contact members 161a, 161b can reduce a contact resistance.

A resistive contact pattern 165 is formed on the light block semiconductor pattern 155 in the peripheral area PA. Furthermore, the resistive contact pattern 165 is formed on the same layer as a layer of the resistive contact members 161a, 161b, and may have substantially the same material as the material of the resistive contact members 161a, 161b. The resistive contact pattern 165 and the light blocking semiconductor pattern 155 can reflect or absorb light emitted from a backlight assembly disposed behind the TFT substrate 100, so that the efficiency of light blocking increases.

Source electrodes 173a, 173b branched from data lines (not shown) and drain electrodes 175a, 175b spaced apart from the source electrodes 173a, 173b are formed on the resistive contact members 161a, 161b and the gate insulating layer 140.

A driving TFT T1 may include the gate electrode 124a, the source electrode 173a, the drain electrode 175a and the semiconductor layer 151a in the peripheral area. A pixel TFT T2 may include the gate electrode 124b, the source electrode 173b, the drain electrode 175b and the semiconductor layer 151b in the display area.

The drain electrode 175a of the driving TFT T1 can be connected with gate lines 121 through a connection part 192. Thus, the driving TFT T1 applies a gate signal to the gate electrode 124b of the pixel TFT T2 through gate lines 121.

The source electrodes 173a, 173b and the drain electrodes 175a, 175b may include a refractory metal such as, for example, chromium, molybdenum, a molybdenum alloy, tantalum, and/or titanium. Furthermore, the source electrodes 173a, 173b and the drain electrodes 175a, 175b may include multiple layers which have, for example, two layers, such as a lower layer (not shown) and an upper layer (not shown). The lower layer may have, for example, molybdenum, a molybdenum alloy, and/or chromium. The upper layer may have, for example, aluminum or an aluminum alloy.

The source electrodes 173a, 173b and the drain electrodes 175a, 175b are spaced apart from the light blocking semiconductor pattern 155 and the resistive contact pattern 165 by a predetermined distance to avoid short-circuit.

A passivation layer 180 is formed on the source electrodes 173a, 173b, the drain electrodes 175a, 175b, the exposed

semiconductor layer **151a**, **151b** and the resistive contact pattern **165**. The passivation layer **180** may have, for example, an organic material having good planarization characteristics and photosensitivity, a low dielectric constant insulating material deposited by Plasma Enhanced Chemical Vapor Deposition (PECVD), such as a-Si:C:O, a-Si:O:F, and an inorganic material, such as, silicon nitride (SiNx). The passivation layer **180** may have a single layer or multiple layers. When the passivation layer **180** includes an organic material, an insulating layer (not shown) can be formed under the organic material to prevent the semiconductor layers **151a**, **151b** and the passivation layer **180** from being contacted. The insulating layer (not shown) may have, for example, silicon nitride (SiNx), and/or silicon oxide (SiO₂).

The passivation layer **180** may have a first contact hole **181** to expose the drain electrode **175a** of the driving TFT T1, a second contact hole **182** to expose the gate lines **121**, and a third contact hole **185** to expose the drain electrode **175b** of the pixel TFT T2.

A plurality of pixel electrodes **190** and a plurality of connection parts **192** are formed on the passivation layer **180**. The plurality of pixel electrodes **190** may have, for example, indium tin oxide (ITO), and/or indium zinc oxide (IZO).

The pixel electrodes **190** are electrically connected with the drain electrode **175b** of the pixel TFT T2 through the third contact hole **185**. The connection part **192** connects the drain electrode **175a** of the driving TFT T1 with the gate lines **121** through the first and second contact holes **181**, **182**.

When a gate signal is applied to the gate electrode **124a** of the driving TFT T1, an electrical signal applied to the source electrode **173a** is applied to the gate lines **121** through the drain electrode **175b** and the connection part **192**.

When a gate signal is applied to the gate electrode **124b** of the pixel TFT T2, a driving signal is applied to the pixel electrodes **190** through the source electrode **173b** and the drain electrode **175b**. The pixel electrodes **190** receiving the driving signal generate an electric field with a common electrode **270**, so that liquid crystal molecules of the liquid crystal layer **400** can be adjusted.

A countering substrate **200** facing the TFT substrate **100** includes an insulating substrate **210** having, for example, transparent glass and a black matrix **220** formed on the insulating substrate **210**. The black matrix **220** may cover the driving TFT T1 and the pixel TFT T2, and prevent light leakage between the pixel electrodes **190**. Furthermore, the black matrix **220** can define an open area facing the pixel electrodes **190**.

Color filters **230** are formed on the insulating substrate **210** and the black matrix **220**, and disposed substantially in the open area defined by the black matrix **220**. The color filters **230** may include, for example, a red color filter, a green color filter, and/or a blue color filter.

An overcoat layer **240** is formed on the black matrix **220** and the color filter **230**. The overcoat layer **240** can act as a planarization layer.

A common electrode **270** is formed on the overcoat layer **240**. The common electrode may have a transparent conductive material, such as, for example, indium tin oxide (ITO) or indium zinc oxide (IZO). In an exemplary embodiment, the common electrode **270** can be formed on the black matrix **220** and the color filters **230**.

A sealant **300** can couple the two substrates **100**, **200**, and can seal the liquid crystal layer **400** filled in the display area. The sealant **300** can cover the driving TFT T1, so that a portion of light which is emitted from a backlight assembly disposed behind the TFT substrate **100** and reflected from the

countering substrate **200** can be absorbed. Thus, an amount of the light that is incident to the driving TFT T1 decreases.

A sealant **300** may be widely formed to cover at least a portion of the light blocking semiconductor pattern as well as the driving TFT T1. Therefore, light which is incident through peripheral area of the driving TFT T1 and reflected from the countering substrate **200** can be absorbed by the sealant **300**. Accordingly, an amount of the light that is incident to the driving TFT T1 decreases.

According to an exemplary embodiment of the present invention, by forming the light blocking semiconductor pattern **155** and the resistive contact pattern **165** adjacent to the driving TFT T1, the light emitted from the backlight assembly can be prevented from being incident to the driving TFT T1. Thus, malfunction of the driving TFT T1 decreases.

The sealant **300** is formed to cover the driving TFT T1 so that the sealant **300** can absorb a portion of light emitted from the backlight assembly and reflected from the countering substrate **200**. Therefore, the light incident to the driving TFT T1 decreases and malfunction of the driving TFT T1 also decreases.

FIG. **2a** to FIG. **2e** are cross-sectional views for showing a method of manufacturing a display device in accordance with an exemplary embodiment of the present invention.

Referring to FIG. **2a**, an insulating substrate **110** having a display area DA to display an image and a peripheral area PA surrounding the display area DA is formed. A first gate electrode **124a** in the peripheral area PA and gate lines **121** and a second gate electrode **124b** connected with the gate lines **121** are formed on the insulating substrate **110**.

The gate lines **121** and the gate electrodes **124a**, **124b** may be formed, for example, by a sputtering process and a photolithography process. The gate lines **121** and the gate electrodes **124a**, **124b** can include a conductive layer which is, for example, aluminum, an aluminum alloy, silver, a silver alloy, copper, a copper alloy, molybdenum, a molybdenum alloy, chromium, titanium, and/or tantalum.

A gate insulating layer **140**, a hydrogenated amorphous silicon layer and a resistive contact member are consecutively formed on the gate lines **121** and the gate electrodes **124a**, **124b** and cover the gate lines **121** and the gate electrodes **124a**, **124b**. The gate insulating layer **140**, the hydrogenated amorphous silicon layer and the resistive contact member are formed by, for example, low temperature chemical vapor deposition (LTCVD) or plasma enhanced chemical vapor deposition (PECVD).

Referring to FIG. **2a**, by patterning the hydrogenated amorphous silicon layer and a doped (N+) amorphous silicon layer, first semiconductor layers **151a**, **151b** and resistive contact members **161a**, **161b** are formed on the gate electrodes **124a**, **124b**. A light blocking semiconductor pattern **155** and a resistive contact pattern **165** are formed in the peripheral area and spaced apart from the first semiconductor layer **151a** and the first resistive contact member **161a**.

Then, a conductive layer can be deposited through a sputtering method. The conductive layer may include a refractory metal such as, for example, chromium, molybdenum, tantalum, and/or titanium.

Referring to FIG. **2b**, source electrodes **173a**, **173b** and drain electrodes **175a**, **175b** are formed on the resistive contact members **161a**, **161b**, respectively, by patterning the conductive layer through a photolithography process.

The first source electrode **173a** and the first drain electrode **175a** are spaced apart from the light blocking semiconductor pattern **155** and the resistive contact pattern **165** to prevent short-circuit.

A portion of the resistive contact member **161a**, **161b** that is not covered by the source electrodes **173a**, **173b** and the drain electrodes **175a**, **175b** is patterned. Thus, the semiconductor layers **151a**, **151b** disposed between the separated resistive contact members **161a**, **161b** are exposed. In an embodiment, an oxygen plasma process can be implemented to the exposed semiconductor layers **151a**, **151b**.

Referring to FIG. 2c, a passivation layer **180** is formed by depositing an organic insulating material or an inorganic insulating material. Then, a plurality of contact holes **181**, **182**, **185** are formed through a photolithography process. Each of the contact holes **181**, **182**, **185** exposes the first and second drain electrodes **175a**, **175b** and a portion of the gate lines **121**. The second contact hole **182** can expose the gate insulating layer **140** under the passivation layer **180** through a photolithography process.

Referring to FIG. 2d, a pixel electrode **190** and a connection part **192** are formed on the passivation layer. The pixel electrode **190** and the connection part **192** may include, for example, indium tin oxide (ITO), and/or indium zinc oxide (IZO).

Referring to FIG. 2e, a sealant **300** is applied along the peripheral area of the TFT substrate **100** to cover the driving TFT T1. The sealant **300** may include, for example, liquid phase sealant or gel type sealant. The sealant **300** may be widely applied along the peripheral area so as to cover at least a portion of the light blocking semiconductor pattern as well as to the driving TFT T1.

Then, the sealant **300** is hardened to couple the TFT substrate **100** with the countering substrate **200**.

A liquid crystal layer **400** is injected into an area defined by the sealant **300** and the two substrates **100**, **200**.

FIG. 3 is a cross-sectional view showing a display device in accordance with an exemplary embodiment of the present invention.

Referring to FIG. 3, a light blocking metal layer **174** is formed on the resistive contact pattern **165** of the TFT substrate **101**. When the source electrodes **173a**, **173b** and the drain electrodes **175a**, **175b** are formed on the resistive contact member **161a**, **161b**, the light blocking metal layer **174** is formed simultaneously with the source electrodes **173a**, **173b** and the drain electrodes **175a**, **175b**.

By forming the light blocking metal layer **174** on the resistive contact pattern **165**, an efficiency of light blocking can be improved.

Although exemplary embodiments of the present invention have been described herein with reference to the accompanying drawings, it is to be understood that the present invention should not be limited to those precise embodiments and that various other changes and modifications may be made by one of ordinary skill in the related art without departing from the scope or spirit of the invention. All such changes and modifications are intended to be included within the scope of the invention as defined by the appended claims.

What is claimed is:

1. A display device comprising:

a thin film transistor (TFT) substrate having a display area and a peripheral area surrounding the display area, wherein the TFT substrate comprises:

a substrate;

a first TFT formed in the peripheral area, the first TFT including a semiconductor layer and a resistive contact member formed on the semiconductor layer;

a light blocking semiconductor pattern; and

a second TFT formed in the display area and including a gate electrode;

a countering substrate;

a sealant coupling the TFT substrate to the countering substrate, wherein the sealant covers the first TFT; and a liquid crystal layer interposed between the TFT substrate and the countering substrate,

wherein the light blocking semiconductor pattern is formed adjacent to the first TFT and is formed from the same layer as the semiconductor layer.

2. The display device of claim 1, further comprising a resistive contact pattern formed on the light blocking semiconductor pattern, wherein the resistive contact pattern is formed from the same layer as the resistive contact member.

3. The display device of claim 1, wherein the first TFT comprises a source electrode and a drain electrode formed on the semiconductor layer.

4. The display device of claim 3, wherein the first TFT further comprises a connection part connecting the drain electrode with a gate line.

5. The display device of claim 3, wherein the source electrode and the drain electrode are spaced apart from the light blocking semiconductor layer by a predetermined distance, respectively.

6. The display device of claim 3, further comprising:

a light blocking metal layer formed on the light blocking semiconductor pattern and comprising substantially the same material as the source electrode and the drain electrode.

7. The display device of claim 1, wherein the light blocking semiconductor layer comprises at least one of hydrogenated amorphous silicon or crystalline silicon.

8. The display device of claim 1, wherein the sealant covers at least a portion of the light blocking semiconductor pattern.

9. A method of manufacturing a display device comprising: forming a thin film transistor (TFT) substrate having a display area and a peripheral area;

forming a first gate electrode in the display area and a second gate electrode in the peripheral area;

forming a semiconductor layer and a resistive contact member on the first gate electrode and the second gate electrode;

forming a first semiconductor layer and a first resistive contact member on the first gate electrode by patterning the resistive contact member and the semiconductor layer;

forming a light blocking semiconductor pattern and a resistive contact pattern in the peripheral area;

forming a conductive layer on the first resistive contact member;

forming a first source electrode and a first drain electrode by patterning the conductive layer; and

forming a sealant interposed between the TFT substrate and the countering substrate, wherein the sealant covers the first semiconductor layer.

10. The method of claim 9, further comprising:

forming a second semiconductor layer and a second resistive contact member on the second gate electrode.

11. The method of claim 9, further comprising:

forming a second source electrode and a second drain electrode on the second resistive contact member.

12. The method of claim 9, further comprising:

forming a passivation layer having a first contact hole to expose the first drain electrode and a second contact hole to expose a gate line; and

forming connection part connecting the first drain electrode with the gate line on the passivation layer.

9

13. The method of claim 9, wherein the first source electrode and the first drain electrode are spaced apart from the light blocking semiconductor pattern by predetermined distance.

14. The method of claim 9, further comprising:
forming a light blocking metal layer on the light blocking semiconductor layer, the light blocking metal layer comprising substantially the same material as the source electrode and the drain electrode.

15. The method of claim 9, wherein the light blocking semiconductor pattern comprises at least one of hydrogenated amorphous silicon or crystalline silicon.

16. The method of claim 9, wherein the sealant covers at least a portion of the light blocking semiconductor pattern.

17. A display device comprising:
a thin film transistor (TFT) substrate having a display area and a peripheral area surrounding the display area, wherein the TFT substrate comprises:
a substrate;

10

a first TFT formed in the peripheral area, the first TFT including a semiconductor layer and a resistive contact member formed on the semiconductor layer;
a light blocking semiconductor pattern; and
a second TFT formed in the display area and including a gate electrode;
a countering substrate;
a sealant coupling the TFT substrate to the countering substrate, wherein the sealant covers the first TFT;
a liquid crystal layer interposed between the TFT substrate and the countering substrate, wherein the first TFT comprises a source electrode and a drain electrode formed on the semiconductor layer; and
a light blocking metal layer formed on the light blocking semiconductor pattern and comprising substantially the same material as the source electrode and the drain electrode.

* * * * *

专利名称(译)	液晶显示器及其制造方法		
公开(公告)号	US7589801	公开(公告)日	2009-09-15
申请号	US11/691111	申请日	2007-03-26
[标]申请(专利权)人(译)	YOON JOO SUN		
申请(专利权)人(译)	YOON JOO-SUN		
当前申请(专利权)人(译)	SAMSUNG ELECTRONICS CO. , LTD.		
[标]发明人	YOON JOO SUN		
发明人	YOON, JOO-SUN		
IPC分类号	G02F1/135 G02F1/1335 G02F1/136		
CPC分类号	G02F1/136209 G02F1/1339 G02F2202/10 G02F1/1368		
助理审查员(译)	CHU , CHRIS		
优先权	1020060053853 2006-06-15 KR		
其他公开文献	US20070291194A1		
外部链接	Espacenet USPTO		

摘要(译)

一种显示装置，包括薄膜晶体管（TFT）基板，面对TFT基板的对置基板，密封剂，以及介于TFT基板和对应基板之间的液晶层。TFT基板包括具有显示区域和外围区域的基板，形成在外围区域中并包括半导体层和形成在半导体层上的电阻接触构件的第一TFT，光阻挡半导体图案，形成在第二TFT中的第二TFT显示区域并包括栅电极。密封剂将TFT基板连接到对应基板，并覆盖第一TFT。

