



US007348971B2

(12) **United States Patent**
Chimura

(10) **Patent No.:** **US 7,348,971 B2**
(45) **Date of Patent:** **Mar. 25, 2008**

- (54) **ACTIVE MATRIX PANEL** 5,426,526 A * 6/1995 Yamamoto et al. 349/42
- (75) Inventor: **Hidehiko Chimura**, Kanagawa (JP) 5,525,957 A 6/1996 Tanaka 348/220
- (73) Assignee: **Semiconductor Energy Laboratory Co., Ltd.** (JP) 5,581,092 A 12/1996 Takemura 257/65
- (*) Notice: Subject to any disclaimer, the term of this patent is extended or adjusted under 35 U.S.C. 154(b) by 345 days. 5,608,251 A 3/1997 Konuma et al. 257/337
- 5,620,905 A 4/1997 Konuma et al. 438/163
- 5,637,187 A 6/1997 Takasu et al. 438/30
- 5,754,158 A * 5/1998 Misawa et al. 345/100
- 5,838,327 A 11/1998 Seong 345/419
- 5,939,731 A 8/1999 Yamazaki et al. 257/59

(21) Appl. No.: **10/914,906**

(22) Filed: **Aug. 10, 2004**

(Continued)

(65) **Prior Publication Data**

US 2005/0012704 A1 Jan. 20, 2005

FOREIGN PATENT DOCUMENTS

EP 0 275 140 7/1988

Related U.S. Application Data

(63) Continuation of application No. 08/539,051, filed on Oct. 4, 1995, now Pat. No. 6,798,394.

(Continued)

(30) **Foreign Application Priority Data**

Oct. 7, 1994 (JP) 6-270565

Primary Examiner—Duc Q Dinh

(74) *Attorney, Agent, or Firm*—Cook, Alex, McFarron, Manzo, Cummings & Mehler, Ltd.

(51) **Int. Cl.**

G09G 3/30 (2006.01)
G09G 5/00 (2006.01)

(57) **ABSTRACT**

(52) **U.S. Cl.** **345/204; 345/206; 345/87; 349/151**

(58) **Field of Classification Search** **345/204–205, 345/87–102, 206**
See application file for complete search history.

In an active matrix panel, a pixel matrix which includes a plurality of gate lines, a plurality of source lines, and thin film transistors is formed on a first transparent substrate. A second transparent substrate is formed opposite to the first transparent substrate. A liquid crystal material is disposed between the first and second transparent substrates. A gate line driver circuit and a source line driver circuit are formed by a P-type, an N-type, a complementary type thin film transistors (including silicon film) or the like on the first transparent substrate. Also, a data processing circuit for performing mask processing or the like is formed by the thin film transistors or the like on the first transparent substrate.

(56) **References Cited**

U.S. PATENT DOCUMENTS

- 4,409,724 A 10/1983 Tasch, Jr. et al. 438/30
- 4,825,202 A 4/1989 Dijon et al. 345/55
- 5,010,326 A * 4/1991 Yamazaki et al. 345/94
- 5,021,774 A 6/1991 Ohwada et al. 340/811
- 5,036,317 A * 7/1991 Buzak 345/74.1
- 5,250,931 A 10/1993 Misawa et al. 345/206
- 5,408,252 A * 4/1995 Oki et al. 345/205

35 Claims, 11 Drawing Sheets

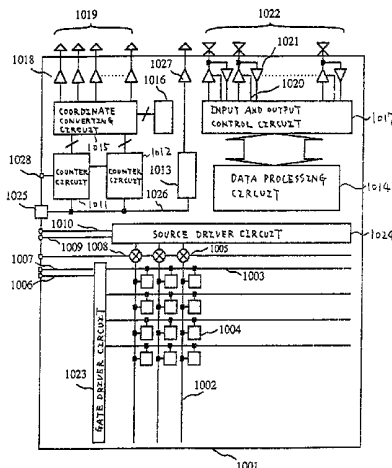

U.S. PATENT DOCUMENTS

				JP	63-217326	9/1988
				JP	01-289917	11/1989
5,982,461	A	11/1999	Hayashi et al.	JP	02-084770	3/1990
6,067,062	A	5/2000	Takasu et al.	JP	04-097292	3/1992
6,104,369	A	8/2000	Inamori et al.	JP	04-181227	6/1992
6,137,464	A	10/2000	Inamori et al.	JP	04-350627	12/1992
6,304,243	B1	10/2001	Kondo et al.	JP	04-362924	12/1992

FOREIGN PATENT DOCUMENTS

EP	0 474 474		3/1992	JP	05-093922	4/1993
EP	0 497 980	A1	8/1992	JP	05-134270	5/1993
EP	0 507 639		10/1992	JP	05-203991	8/1993
EP	0 593 266		4/1994	JP	05-210364	8/1993
EP	0 588 398	A2	11/1997	JP	06-123896	5/1994
EP	0 588 398	A3	11/1997	JP	06-160039	6/1994
EP	0 588 398	B1	11/1997	JP	06-202160	7/1994
JP	61-137194		6/1986	JP	07-140938	6/1995

* cited by examiner

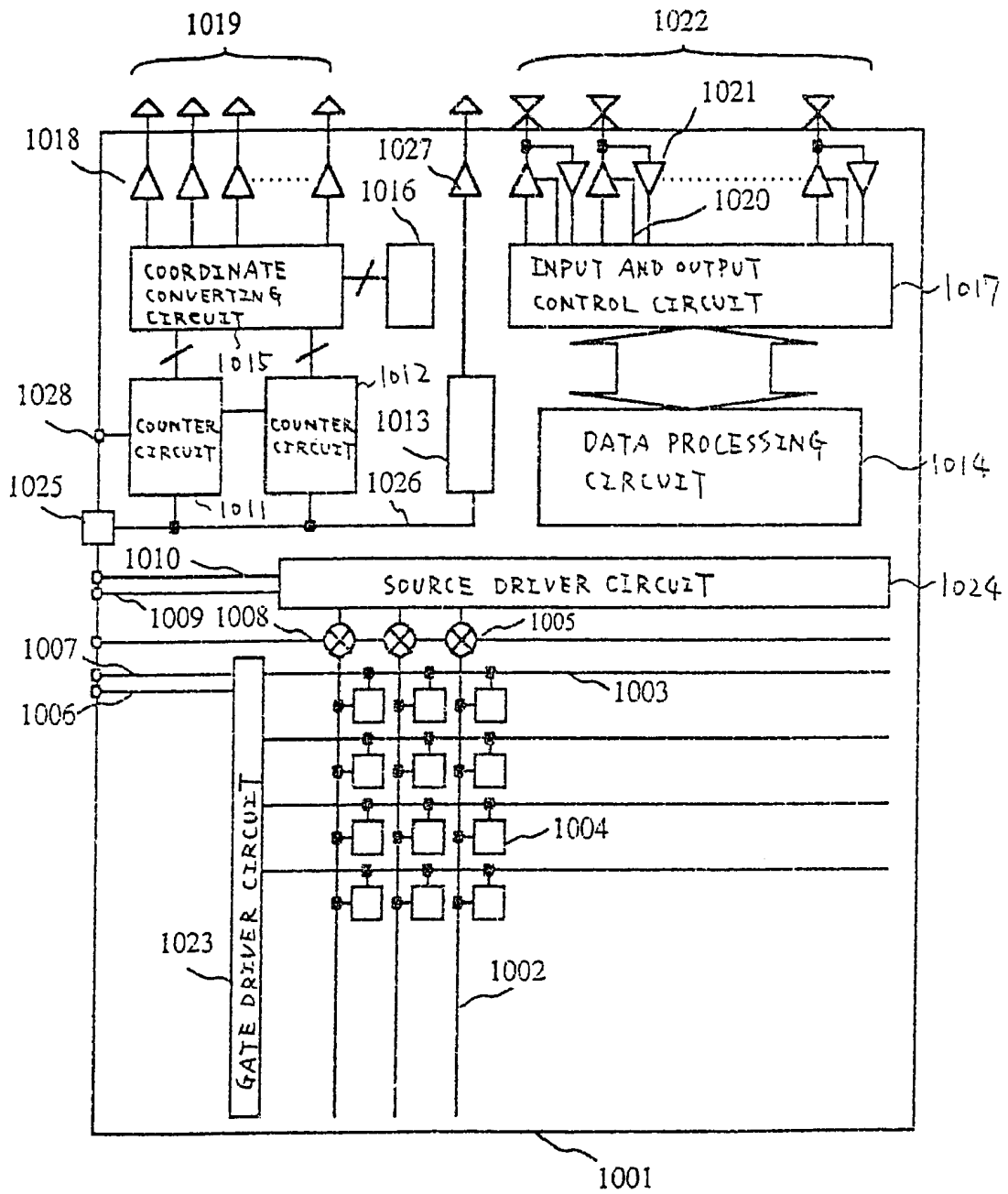

FIG. 1

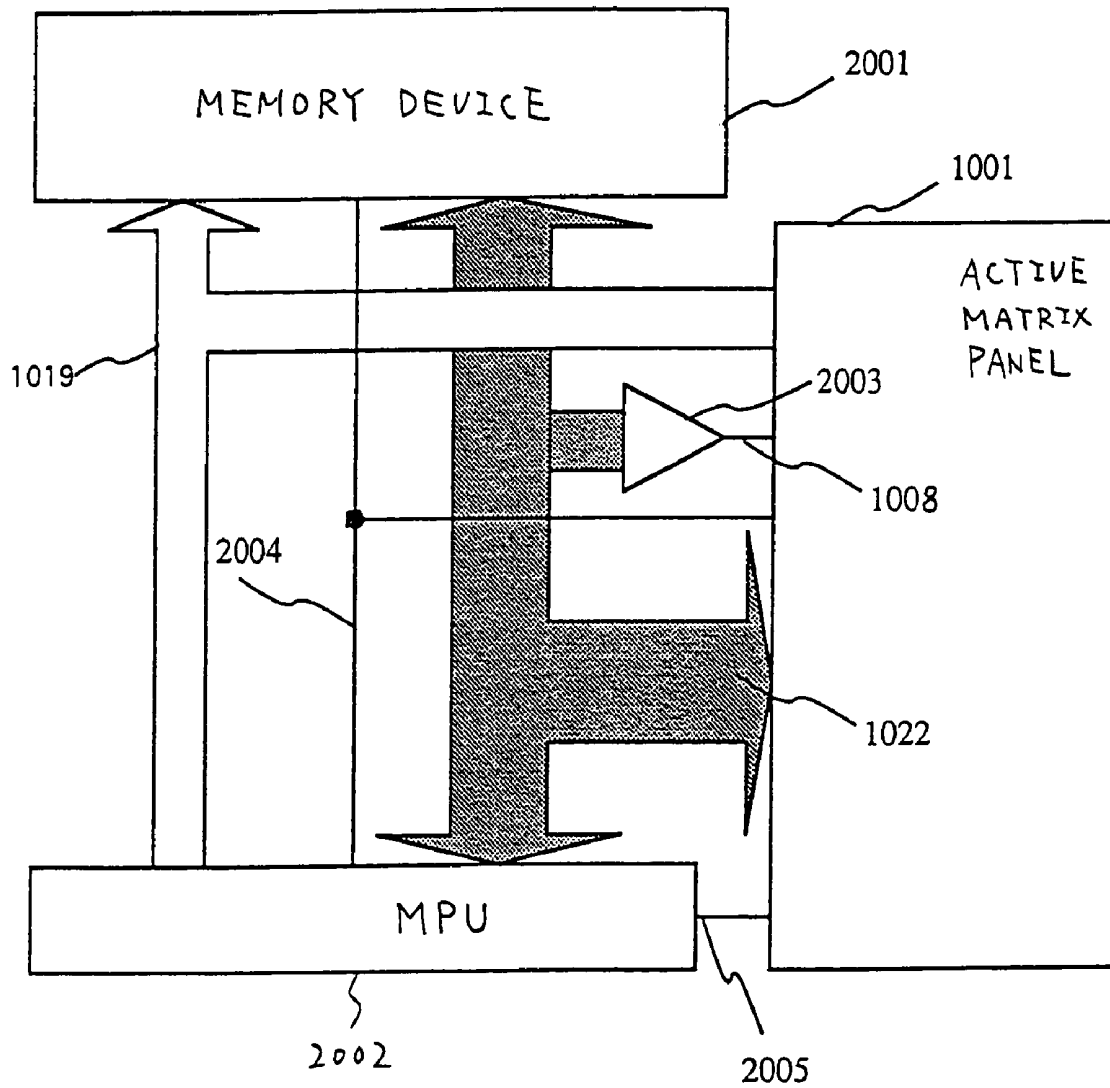

FIG. 2

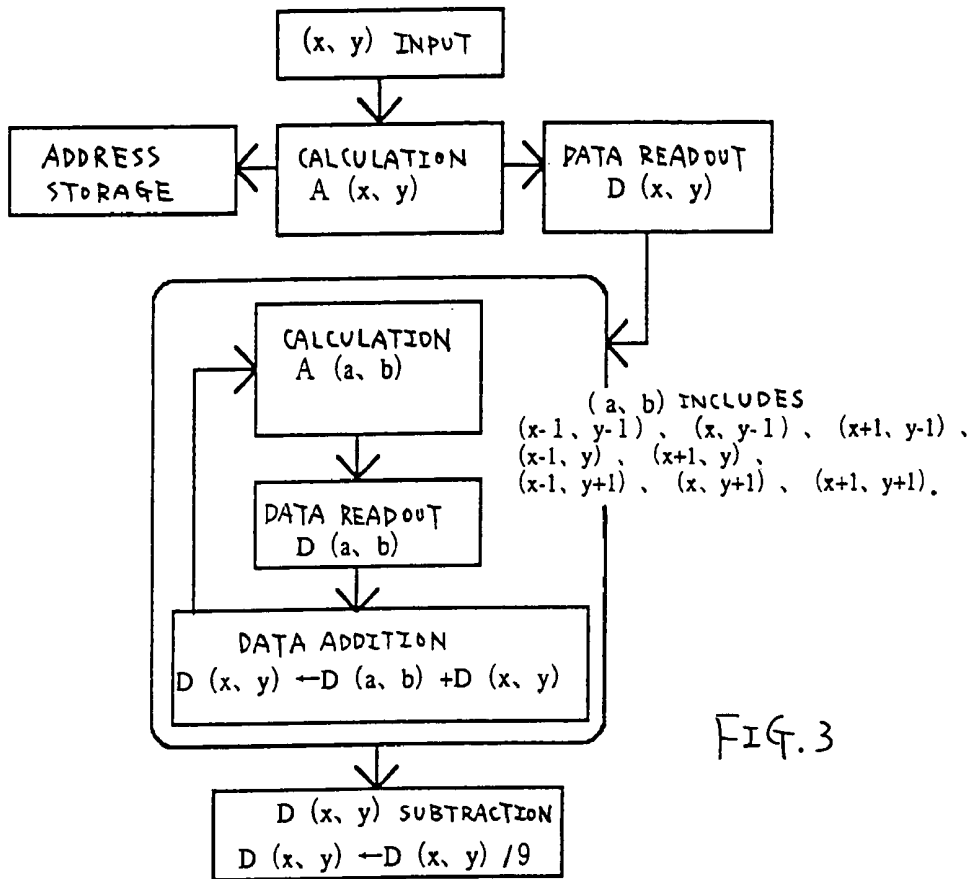

FIG. 3

COORDINATE

$(x-1, y-1)$	$(x, y-1)$	$(x+1, y-1)$
$(x-1, y)$	(x, y)	$(x+1, y)$
$(x-1, y+1)$	$(x, y+1)$	$(x+1, y+1)$

FIG. 4A

IMAGE DATA (GRADATION)

$P(x-1, y-1)$	$P(x, y-1)$	$P(x+1, y-1)$
$P(x-1, y)$	$P(x, y)$	$P(x+1, y)$
$P(x-1, y+1)$	$P(x, y+1)$	$P(x+1, y+1)$

FIG. 4B

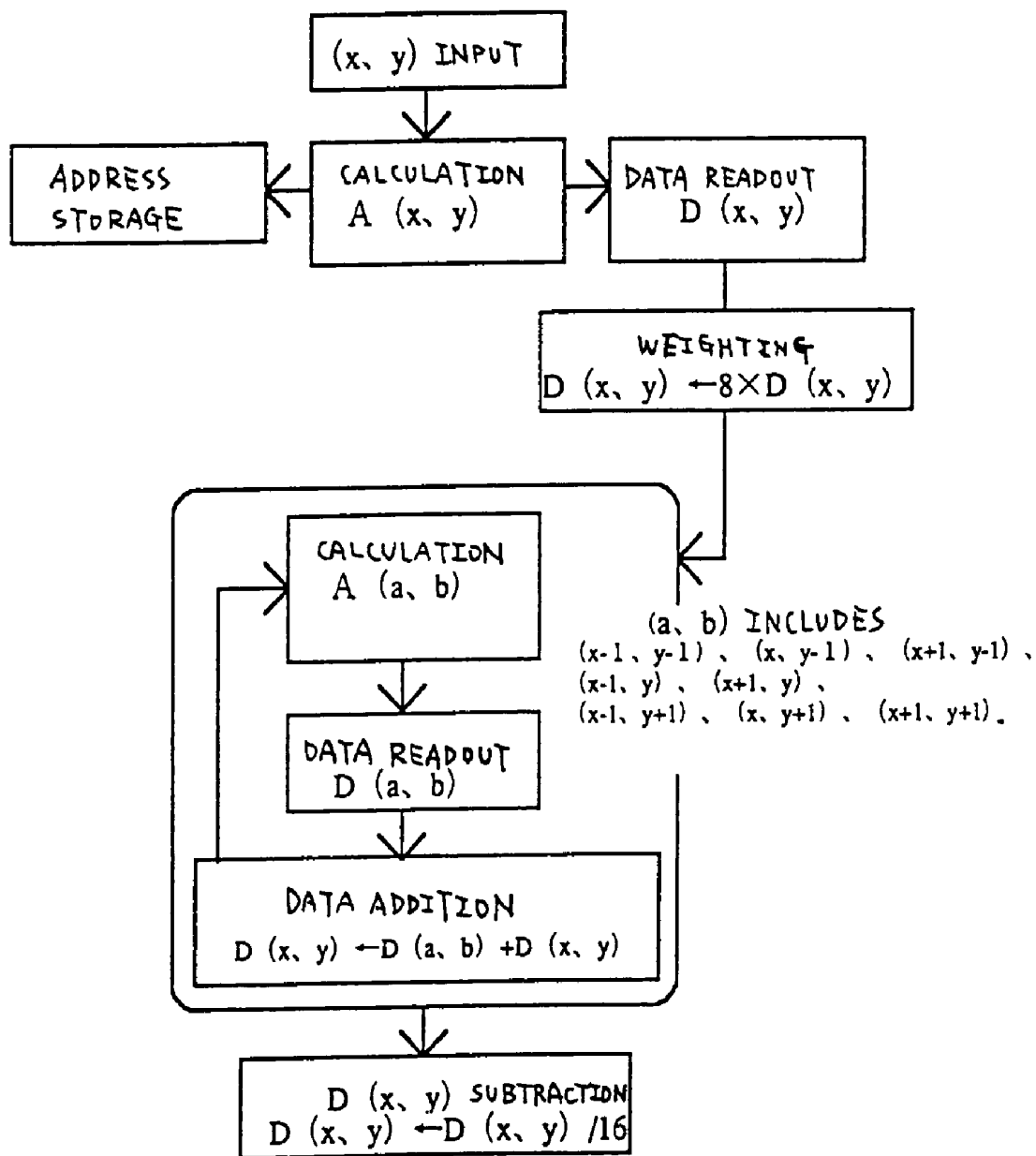

FIG. 5

(1,1)	(2,1)	(3,1)	(N-2,1)	(N-1,1)	(N,1)
(1,2)	(2,2)	(3,2)	(N-2,2)	(N-1,2)	(N,2)
(1,3)	(2,3)	(3,3)	(N-2,3)	(N-1,3)	(N,3)
⋮				⋮	
(1,M-2)	(2,M-2)	(3,M-2)	(N-2,M-2)	(N-1,M-2)	(N,M-2)
(1,M-1)	(2,M-1)	(3,M-1)	(N-2,M-1)	(N-1,M-1)	(N,M-1)
(1,M)	(2,M)	(3,M)	(N-2,M)	(N-1,M)	(N,M)

 MASK PROCESSING PIXEL

FIG. 6

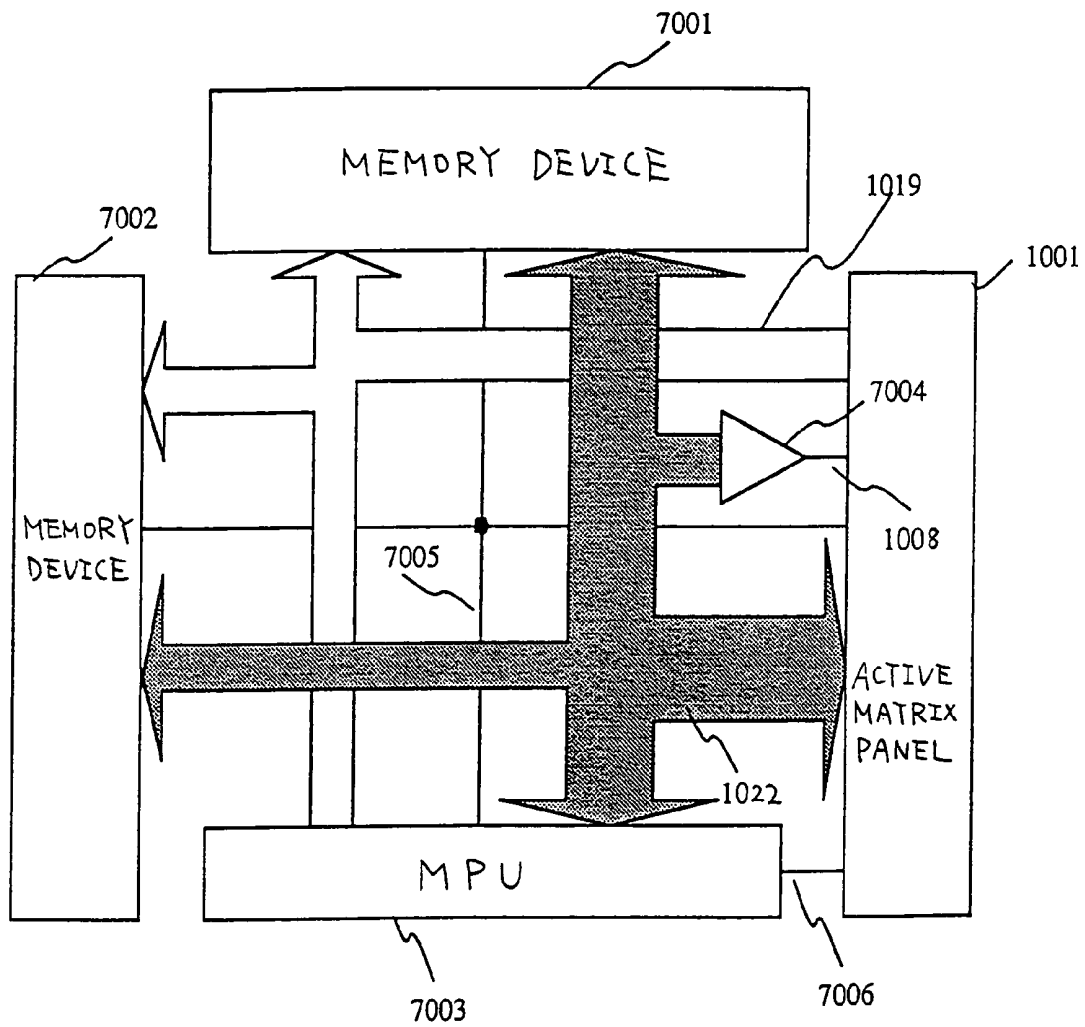

FIG. 7

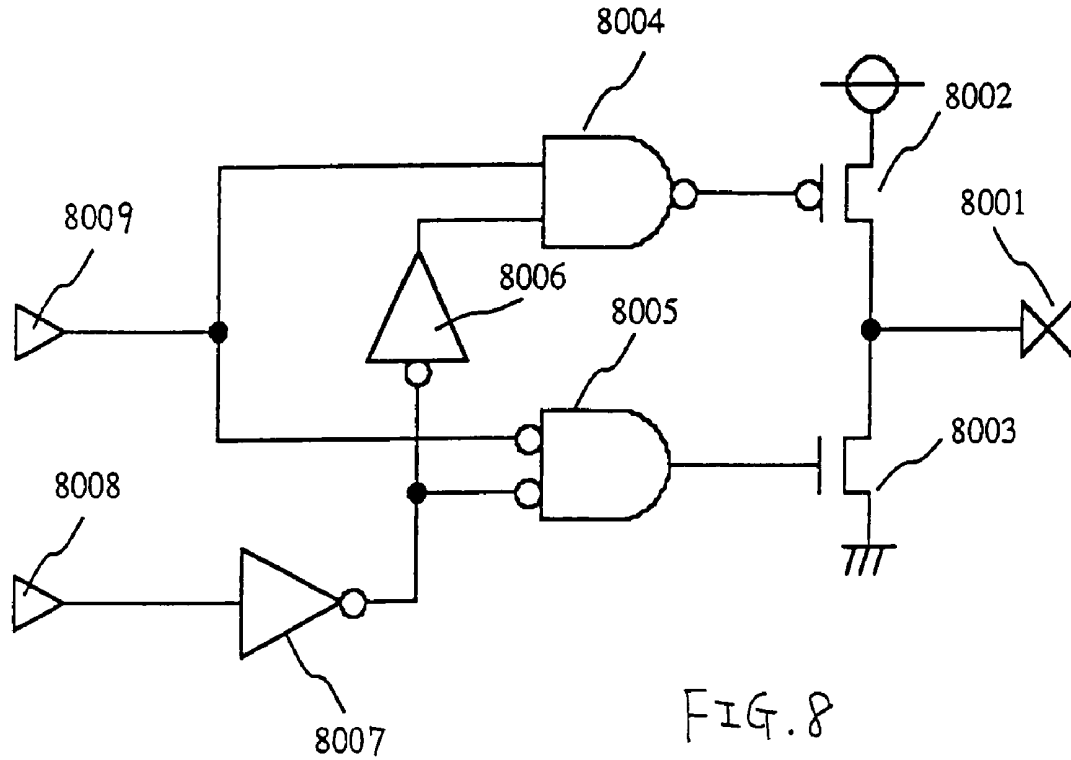

FIG. 8

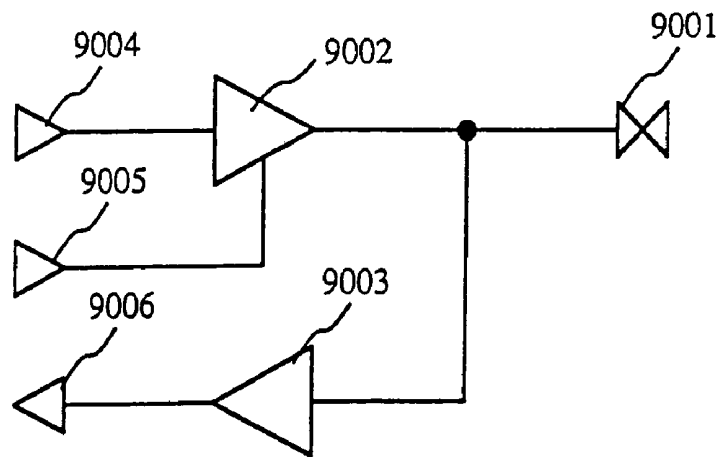

FIG. 9

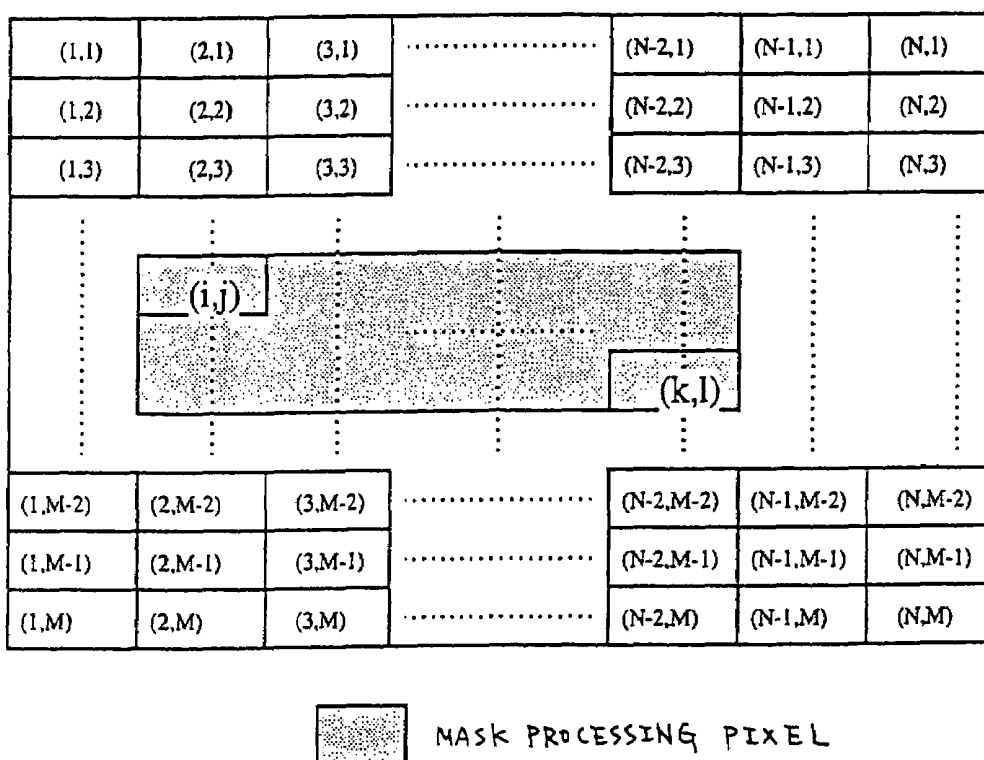

FIG. 10

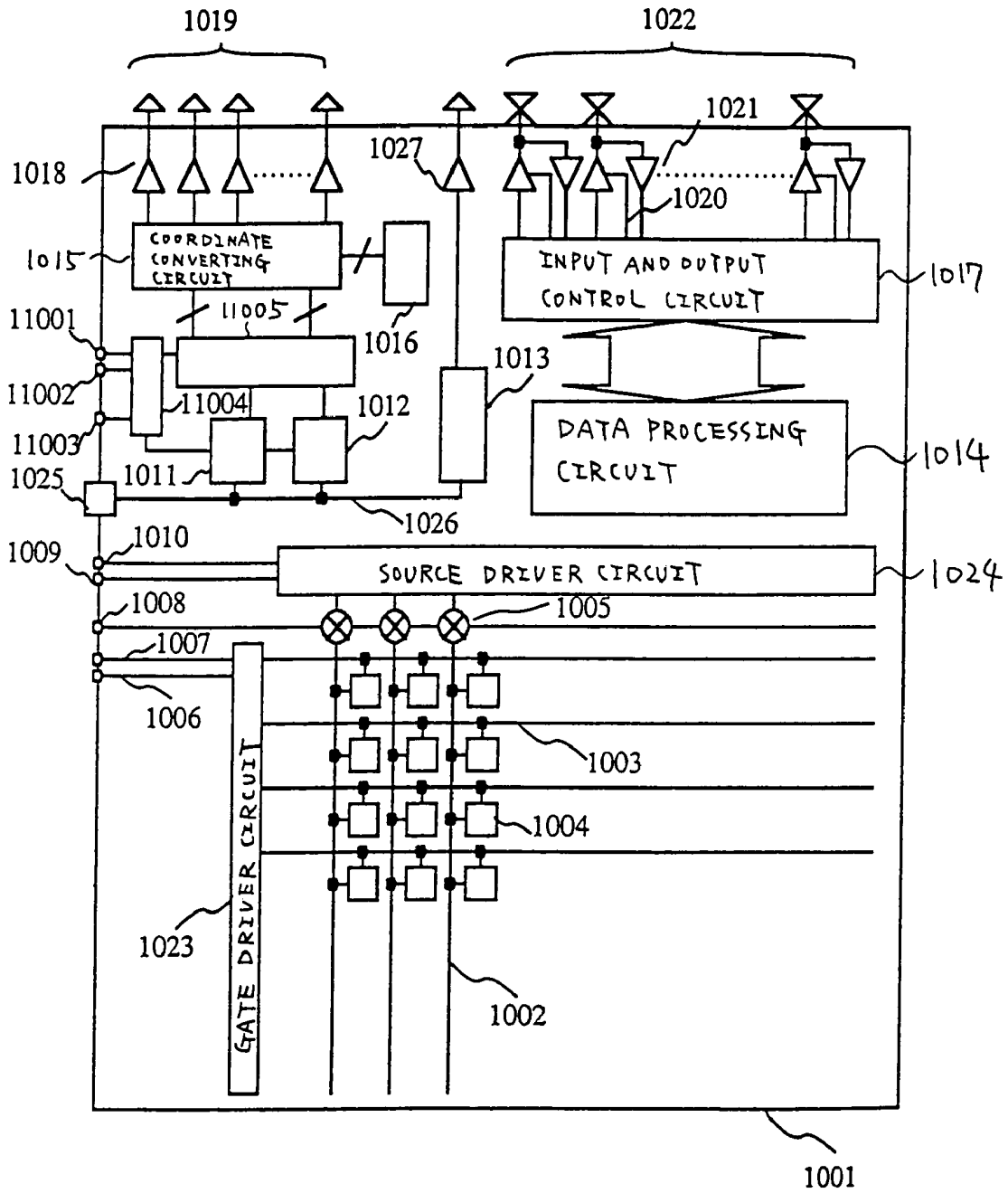

FIG. 11

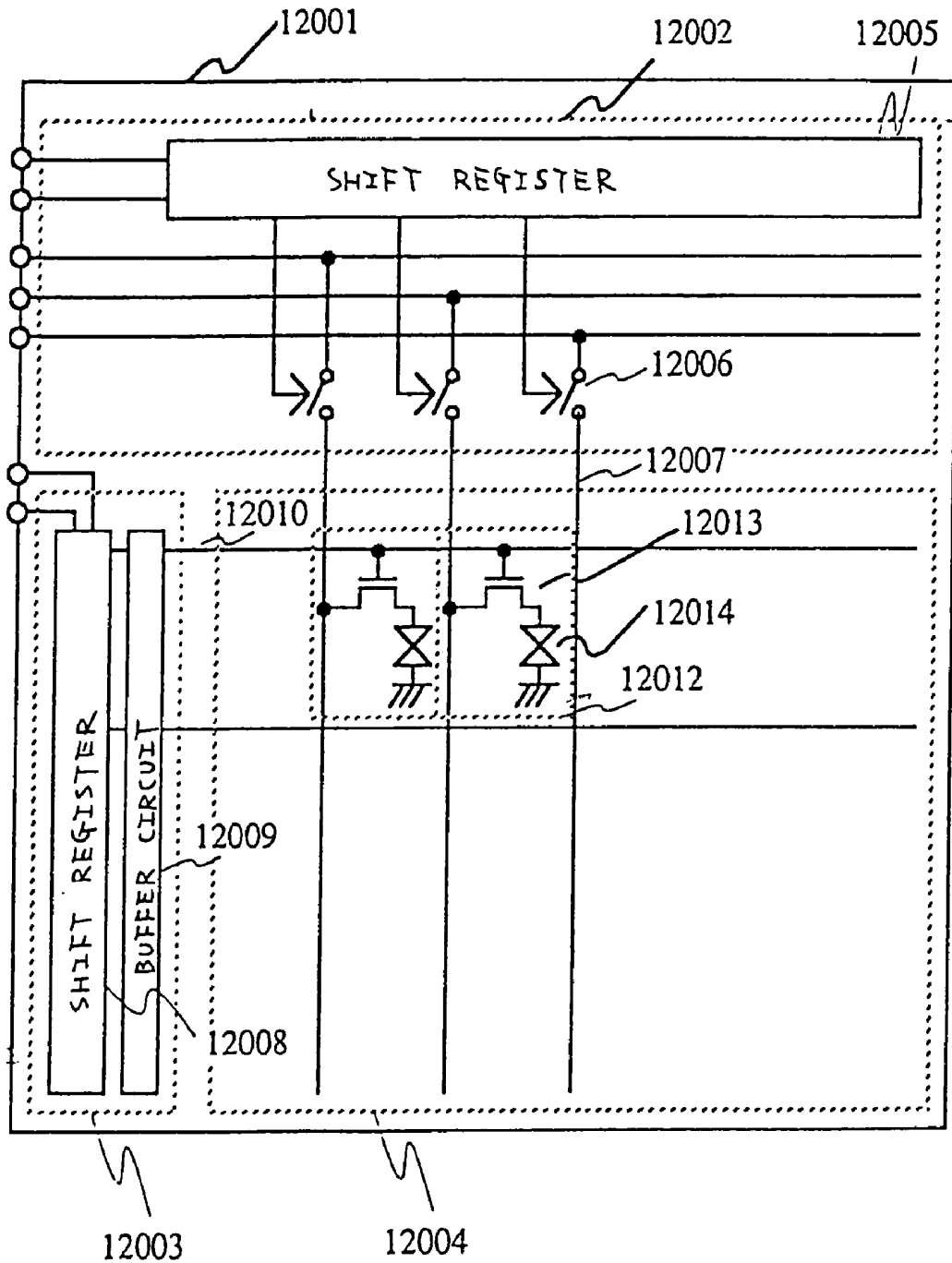

FIG. 12

PRIOR ART

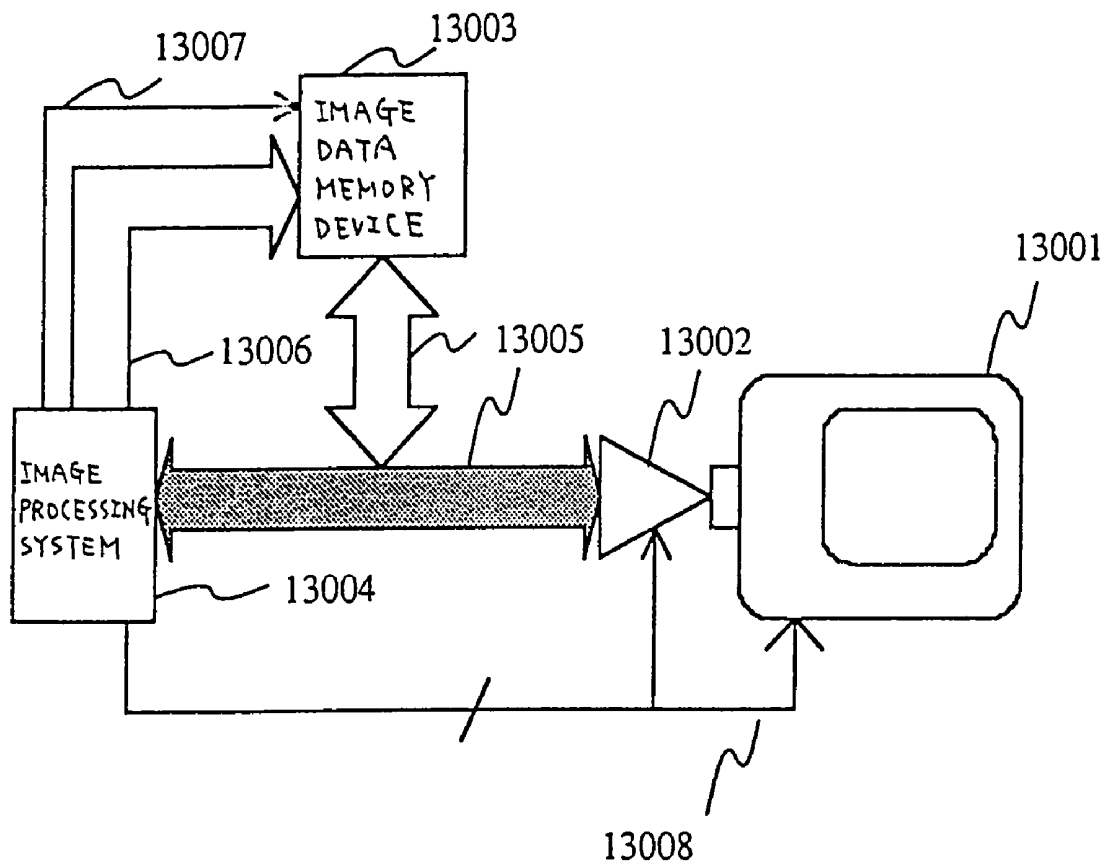

FIG. 13
PRIOR ART

ACTIVE MATRIX PANEL

This application is a continuation of U.S. application Ser. No. 08/539,051, filed on Oct. 4, 1995 now U.S. Pat. No. 6,798,394.

BACKGROUND OF THE INVENTION

1. Field of the Invention

The present invention relates to an active matrix panel using thin film transistors (TFTs).

2. Description of the Related Art

FIG. 12 shows a conventional active matrix panel. In an active matrix panel **12001**, as disclosed in Japanese Patent unexamined published No. 1-289917, a source line driver circuit **12002**, a gate line driver circuit **12003**, and a pixel matrix **12004** are formed on the same (single) substrate.

The source line driver circuit **12002** has a shift register **12005** and a sample holding circuit **12006** formed by TFTs and is connected to the pixel matrix **12004** through a source line **12007**.

The gate line driver circuit **12003** has a shift register **12008** and a buffer circuit **12009** and is connected with the pixel matrix **12004** through a gate line **12010**.

In the pixel matrix **12004**, a pixel **12012** is formed at an intersection of the source line **12007** and the gate line **12010** and has a TFT **12013** and a liquid crystal cell **12014**.

FIG. 13 shows a system for processing image data stored in a memory device such as a random access memory (RAM) using a software by a microcomputer. This system has a liquid crystal display device **13001**, a digital signal/analog signal converting circuit (D/A converting circuit) **13002**, an image data memory device **13003**, an image processing system **13004** including a microcomputer (not shown), a data bus **13005**, and an address bus **13006**. Numeral **13007** represents a memory device control signal, numeral **13008** represents a control signal for the liquid crystal display device **13001** and the D/A converting circuit **13002**.

The operation is described below. The contents of image processing are programmed by C language or the like and then compiled in the system **13004**. In accordance with the contents of the image processing, the image data stored in the memory device **13003** is read out on the data bus **13005**, and then data processing is performed by the system **13004**. The processed image data is stored in the memory device **13003** or displayed on the liquid crystal display device **13001** through the DA converting circuit **13002**. Thus, the liquid crystal display device **13001** has only function for displaying the image data.

In a conventional active matrix panel, there are the following problems.

(1) Miniaturization of a display device and a system is hindered.

Conventionally, as shown in FIG. 12, since an active matrix panel has only a circuit for driving each pixel in a pixel matrix, access to a circuit for displaying the pixel circuit, in particular, an image processing system, is performed from an external of the active matrix panel. Recently, because of increase of image data and complication of data processing, processing in an external is increased, so that the amount of the data processing exceeds processing capacity of a microprocessing unit (MPU). Accordingly, in order to decrease the amount of data processing of the MPU, an exclusive external processing unit is incorporated in a semiconductor integrated circuit. However, this increases the

number of parts for an image display apparatus having image processing operation and hinders miniaturization of a system.

(2) A region which is not used is present in a panel.

Since a conventional active matrix panel includes driver circuits for pixels, gate lines and source lines, a region which is not used is present in a panel. If an external part can be arranged in the region, further miniaturization of a display system can be performed by effectively using a physical space.

(3) A high speed operation of a system for performing image processing is prevented.

In order to control pixels, it is necessary to operate an MPU in a system other than a panel. However, since an image processing technique is complexed year by year and therefore a software is complexed and increased, a data processing time of an MPU is increased and an access time to a memory device is also increased. This is because an MPU ensures a data bus to access the memory device. To solve this, it is effective to perform parallel processing by using a special purpose hardware. However, the number of parts increases. Therefore, the number of parts is decreased. By this, a system cannot be operated at a high speed, so that a process time of a MPU is further increased.

SUMMARY OF THE INVENTION

An object of the present invention is to solve the above problems and to provide an active matrix panel having a high speed with miniaturization.

According to the present invention, there is provided an active matrix panel including: a first transparent substrate; a second transparent substrate arranged opposite to the first transparent substrate; a liquid crystal material arranged between the first and second transparent substrate, wherein the first transparent substrate includes, a plurality of gate lines, a plurality of source lines, a plurality of pixel thin film transistors formed in intersections of the gate lines and the source lines, a gate line driver circuit which is formed by first thin film transistors and connected to the gate lines, a source line driver circuit which is formed by second thin film transistors and connected to the source line, and

a processing circuit, formed by the third thin film transistors, for processing signals supplied to the source lines.

The processing circuit has at least one of the following elements:

(1) a standard clock generator circuit constructed by a P-type, an N-type or a complementary type MOS transistor formed using a silicon film, or a thin film diode of MIM (metal-insulator metal), NIN, PIP, PIN, NIP or the like;

(2) a counter circuit constructed by a P-type, an N-type or a complementary type MOS transistor formed using a silicon film, or a thin film diode of MIM (metal-insulator metal), NIN, PIP, PIN, NIP or the like;

(3) a divider circuit constructed by a P-type, an N-type or a complementary type MOS transistor formed using a silicon film, or a thin film diode of MIM (metal-insulator metal), NIN, PIP, PIN, NIP or the like;

(4) a transferring element circuit for transferring a signal from external to the active matrix panel, constructed by a P-type, an N-type or a complementary type MOS transistor formed using a silicon film, or a thin film diode of MIM (metal-insulator metal), NIN, PIP, PIN, NIP or the like;

(5) a transferring element circuit for transferring a signal from the active matrix panel to the external, constructed by a P-type, an N-type or a complementary type MOS transistor

formed using a silicon film, or a thin film diode of MIM (metal-insulator metal), NIN, PIP, PIN, NIP or the like; and

(6) a transferring element circuit for transferring a signal from the active matrix panel to external and transferring a signal from the external to the active matrix panel, constructed by a P-type, an N-type or a complementary type MOS transistor formed using a silicon film, or a thin film diode of MIM (metal-insulator metal), NIN, PIP, PIN, NIP or the like.

In the above structure of the present invention, the image data is read out from a plurality of memory devices for storing image data under readout control and then processed, so that the processed image data is transferred to pixels to display the image data on the pixels. That is, in the active matrix panel, a pixel matrix is driven, and further, processing, signal transfer from the active matrix panel to the external, and control of memory devices can be performed.

Therefore, without operation of an MPU, image data is processed and displayed on the pixel matrix by direct accesses to the plurality of memory devices, and the number of parts for data processing can be small.

BRIEF DESCRIPTION OF THE DRAWINGS

FIG. 1 shows an active matrix panel of an embodiment of the present invention;

FIG. 2 shows a display system of the embodiment;

FIG. 3 shows steps of an algorithm for mask processing;

FIGS. 4A and 4B show examples of image data;

FIG. 5 shows steps of an algorithm which data is weighted for mask processing;

FIG. 6 shows a pixel range in which mask processing is performed;

FIG. 7 shows a display system of another embodiment;

FIGS. 8 and 9 show a bidirectional buffer;

FIG. 10 shows an example of mask processing to a portion of display area;

FIG. 11 shows an active matrix panel of another embodiment;

FIG. 12 shows a conventional active matrix panel; and

FIG. 13 shows a conventional data processing system.

DETAILED DESCRIPTION OF THE PREFERRED EMBODIMENTS

Embodiment 1

In the embodiment, a method for mask processing (decrease of noise of an image) is described as concrete image processing. The mask processing is necessary to correct an image, in particular, to remove isolated point noise in a case wherein image data is produced from image reading apparatus such as a handy scanner.

FIG. 1 shows an active matrix panel of Embodiment 1, and the following circuits are formed on the same transparent substrate.

In an active matrix panel **1001**, a source line **1002** having N-lines and a gate line **1003** having M-lines are provided at a matrix form, and pixels **1004** are connected to intersections of the source line **1002** and the gate line **1003**, respectively. Accordingly, since the pixels **1004** are provided at N×M matrices by arranging N-pixels in a horizontal direction (X-direction) and M-pixels in a vertical direction (Y-direction), a desired one of the pixels **1004** can be determined by designating an address A(x,y).

The source line **1002** is connected to a source driver circuit **1024** through sample hold circuits **1005**. The gate line

1003 is connected to the outputs of a gate driver circuit **1023**. A clock line **1006** and a start line **1007** are connected to the inputs of the gate driver circuit **1023**. A video line **1008** is connected to the input of the sample hold circuit **1005**. A clock line **1009** and a start line **1010** are connected to the source driver circuit **1024**. The gate driver circuit **1023** and the source driver circuit **1024** are formed by using a P-type, an N-type, or a complementary type MOS thin film transistor (TFT), or a thin film diode of MIM (metal-insulator metal), NIN, PIP, PIN, NIP or the like.

Also, in the active matrix panel **1001**, a circuit for designating an address of the pixels **1004** to be mask-processed is provided. Through a standard clock line **1026**, the output of a standard clock generating circuit **1025** is connected to an X-coordinate counter circuit **1011** for counting an X-coordinate value, a Y-coordinate counter circuit **1012** for counting a Y-coordinate value, and a memory device control circuit **1013** for generating a clock signal to control read and write to external memory devices (not shown). The outputs of the counter circuits **1011** and **1012** are sequentially connected to a coordinate converting circuit **1015** which is connected to an address holding circuit **1016**, address buffers **1018**, and address buses **1019**, and output to an external control portion (not shown). The output of the memory device control circuit **1013** is connected to the external control portion outside the active matrix panel **1001** through a clock buffer **1027** by a signal on an averaging start signal line **1028**. The counter circuits **1011** and **1012**, the memory device control circuit **1013**, the coordinate converting circuit **1015**, and the address holding circuit **1016** are formed by using a P-type, an N-type, or a complementary type MOS TFT, or a thin film diode of MIM (metal-insulator metal), NIN, PIP, PIN, NIP or the like.

Further, in the active matrix panel **1001**, a data processing circuit **1014** for performing image processing is provided. An input and output control circuit **1017** which can read and write data, an input and output select signal line **1020**, bidirectional buffers **1021**, and data buses **1022** are sequentially connected to the data processing circuit **1014**, and each element can input and output a signal (data). The data buses **1022** are connected to the external control portion outside the active matrix panel **1001**. The data processing circuit **1014** and the input and output control circuit **1017** are formed by using a P-type, an N-type, or a complementary type MOS TFT, or a thin film diode of MIM (metal-insulator metal), NIN, PIP, PIN, NIP or the like.

FIG. 2 shows a display system. A memory device **2001** for storing image data and a microprocessing unit (MPU) **2002** for controlling the entire system are provided outside the active matrix panel **1001**. By the address buses **1019**, the outputs of the active matrix panel **1001** and the MPU **2002** are connected to the memory device **2001**. Also, by the data buses **1022**, the bidirectional buffer **1021** of the active matrix panel **1001**, the memory device **2001**, and the MPU **2002** can input and output a signal (data). The data buses **1022** are connected to a D/A converter **2003**. The D/A converter **2003** is connected to the active matrix panel **1001** through the video signal line **1008**. By a memory device control line **2004**, the active matrix panel **1001** is connected to the memory device **2001** and the MPU **2002**. Also, by a control signal line **2005**, the active matrix panel **1001** is connected to the MPU **2002**.

FIGS. 8 and 9 show examples of a bidirectional buffer. In FIG. 8, an output pin **8001** is connected to a connection terminal connecting a drain electrode of a P-type transistor **8002** with a source electrode of an N-type transistor **8003**. A gate electrode of the P-type transistor **8002** is connected

to the output of an NAND circuit **8004**, and a gate electrode of the N-type transistor **8003** is connected to the output of an NOR circuit **8005**. One of input terminals of the NAND circuit **8004** is connected to an input pin **8009**, and the other input terminal of the NAND circuit **8004** is connected to an inverter circuit **8006**. Also, one of input terminals of the NOR circuit **8005** is connected to the input pin **8009**, and the other input terminal of the NOR circuit **8005** is connected to an inverter circuit **8007**. The output of the inverter circuit **8007** is connected to the inverter circuit **8006**. An output state control pin **8008** is connected to the inverter circuit **8007**.

In FIG. 9, a bidirectional pin **9001** is connected to an output terminal of a tristate buffer **9002** and an input terminal of an input buffer **9003**. The tristate buffer **9002** is connected to an input pin **9004** and an input and output select pin **9005**. The input buffer **9003** is connected to an input pin **9006**.

In mask processing, when a signal on the averaging start signal line **1028** is a H (high) level, in synchronous with a clock signal generated by the standard clock generating circuit **1025**, the X- and Y-coordinate counter circuits **1011** and **1012** count up a coordinate (x,y), from the coordinate (2,2), sequentially.

When the signal on the averaging start signal line **1028** is a L (low) level, the X- and Y-coordinate counter circuits **1011** and **1012** stop count of the coordinate, so that the coordinate (x,y) is determined. In the coordinate converting circuit **1015**, an address A(x,y) of the pixels **1004** is determined in accordance with the coordinate (x,y). Therefore, image data D(x,y) of the address A(x,y) in the pixels **1004** is mask-processed.

FIG. 3 shows steps of algorithm for mask processing. The address A(x,y) determined by the coordinate converting circuit **1015** is stored in the address holding circuit **1016** and output to the memory device **2001** through the address buffers **1018** and the address buses **1019** at the same time. The image data D(x,y) is read out from the memory device **2001** by the MPU **2002** and output to the data processing circuit **1014**. As the image data, gradation data is used.

In FIG. 4A, eight addresses A(x-1,y-1), A(x,y-1), A(x+1,y-1), A(x-1,y), A(x+1,y), A(x-1,y+1), A(x,y+1), and A(x+1,y+1) around the address A(x,y) in the pixels **1004** are generated. Therefore, in FIG. 4B, image data D(x-1,y-1), D(x,y-1), D(x+1,y-1), D(x-1,y), D(x+1,y), D(x-1,y+1), D(x,y+1), and D(x+1,y+1) corresponding to these addresses A(x,y) are sequentially read out from the memory device **2001** and output to the data processing circuit **1014**. In the data processing circuit **1014**, these image data D(x,y) are sequentially added. The added result is divided by nine corresponding to the total number of the image data D, to obtain the averaged image data D'(x,y) of the address A(x,y).

When a write signal is input from the memory device control circuit **1013** to the memory device **2001**, through the address buffers **1018** and address buses **1019**, the address A(x,y) is input from the address holding circuit **1016** to the memory device **2001** and stored. At the same time, through the data buses **1022**, the averaged image data D'(x,y) is input from the data processing circuit **1014** to the memory device **2001** and stored.

The above processing is performed for the pixels **1004** with respect to addresses A(2,2) to A(N-1,M-1), as shown in FIG. 6, to mask-process the entire image.

In order to perform the algorithm of FIG. 3, the memory device control circuit **1013** is set to be a read state and input and output of the bidirectional buffers **1021** may be changed by the input and output control circuit **1017**.

In this algorithm, the image data D(x,y) is averaged simply. However, the image data D(x,y) may be weighted. FIG. 5 shows an algorithm for weighting the image data D(x,y) to enhance the averaged image data D'(x,y).

The address A(x,y) determined by the coordinate converting circuit **1015** is stored in the address holding circuit **1016** and output to the memory device **2001** through the address buffers **1018** and the address buses **1019** at the same time. The image data D(x,y) is read out from the memory device **2001** by the MPU **2002** and output to the data processing circuit **1014**. In the data processing circuit **1014**, the weighted image data D(x,y) is obtained by multiplying the image data D(x,y) by eight representing the total number of image data D(x,y) to be added later.

In FIG. 4A, eight addresses A(x-1,y-1), A(x,y-1), A(x+1,y-1), A(x-1,y), A(x+1,y), A(x-1,y+1), A(x,y+1), and A(x+1,y+1) around the address A(x,y) in the pixels **1004** are generated. Therefore, in FIG. 4B, image data D(x-1,y-1), D(x,y-1), D(x+1,y-1), D(x-1,y), D(x+1,y), D(x-1,y+1), D(x,y+1), and D(x+1,y+1) corresponding to these addresses A(x,y) are sequentially read out from the memory device **2001** and output to the data processing circuit **1014**. In the data processing circuit **1014**, these image data D(x,y) are sequentially added to the weighted image data D(x,y). The result is divided by sixteen, to obtain the averaged image data D'(x,y) of the address A(x,y).

Embodiment 2

In Embodiment 1, only one external memory device is provided in the active matrix panel **1001**. In this case, since original image data is overwritten, a mask-processing result cannot be confirmed. Therefore, in Embodiment 2, two external memory devices are provided outside the active matrix panel **1001**, so that image data before and after mask processing are stored.

FIG. 7 shows a display system of Embodiment 2. The active matrix panel is the same structure as that in Embodiment 1. Two memory devices **7001** and **7002** for storing image data and an MPU **7003** for controlling the entire system are provided outside the active matrix panel **1001**. The outputs of the active matrix panel **1001** and the MPU **7003** are connected to the memory devices **7001** and **7002** through address buses **1019**. Through the data buses **1022**, the active matrix panel **1001**, the memory devices **7001** and **7002**, and the MPU **7003** are connected each other to input and output a signal (data). The data buses **1022** are connected to a D/A converter **7004** which is connected to the active matrix panel **1001** through the video signal line **1008**. The memory device control line **7005** connects with the active matrix panel **1001**, the memory devices **7001** and **7002**, and the MPU **7003** each other. Through a control signal line **7006**, the active matrix panel **1001** is connected to the MPU **7003**.

In mask processing, the algorithm of FIG. 3 or 5 is used. Image data stored in the memory device **7001** is mask-processed, and then the mask-processed image data is stored in the memory device **7002**.

Embodiment 3

In Embodiments 1 and 2, examples of mask processing for the entire image are described. In Embodiment 3, in order to further shorten the processing time, mask processing is not performed for an area which is not necessary to mask-process.

FIG. 11 shows an active matrix panel of the embodiment. The active matrix panel is the same structure as that in FIG. 1 except for a circuit for designating an address of a pixel. In FIG. 11, the outputs of an X-direction mask processing start/end signal line 11001, a Y-direction mask processing start/end signal line 11002, and a mask processing start signal line 11003 are connected to a subtraction circuit 11004. The output of the subtraction circuit 11004 is connected to the X- and Y-coordinate counter circuits 1011 and 1012 and the coordinate converting circuit 1015. The subtraction circuit 11004 and a coordinate value generating circuit 11005 are formed by a P-type, an N-type, or a complementary type MOS TFT, or a thin film diode of MIM (metal-insulator metal), NIN, PIP, PIN, NIP or the like.

The active matrix panel has, as similar to Embodiment 1, $N \times M$ pixels (N is the number of X-direction pixels and M is the number of Y-direction pixels). In the following symbols i , j , k , and l , the relationships $1 < i$, $k < N$, $1 < j$, and $1 < M$ is set.

In mask processing, a mask processing start signal is input from the mask processing start signal line 11003 to the subtraction circuit 11004. Also, From the X- and Y-direction mask processing start/end signal lines 11001 and 11002, a start coordinate (i, j) and an end coordinate (k, l) which are mask-processed are input to the subtraction circuit 11004. In the subtraction circuit 11004, an X-direction counter end value ($p = k - l + 1$) and a Y-direction counter end value ($q = l - j + 1$) are calculated, so that control is performed to reset the counter value of the X-coordinate counter circuit 1011 by using a p -value and to reset the counter value of the Y-coordinate counter circuit 1012 by using a q -value. Therefore, the X-coordinate counter circuit 1011 is a p -coded (including binary, decimal or the like) counter circuit, and the Y-coordinate counter circuit 1012 is a q -coded (including binary, decimal or the like) counter circuit.

In the coordinate generating circuit 11005, addresses ($i + X$ -coordinate counter value, $j + Y$ -coordinate counter value) are calculated to generate the addresses $A(x, y)$ representing an area to be mask-processed. The algorithm of Embodiment 1 is executed for the pixels 1004 corresponding to the generated addresses $A(x, y)$, so that mask processing is performed for only an area of FIG. 10 in the pixels 1004.

In the embodiment, in order to store image data before and after mask processing, as shown in Embodiment 2, two or more memory devices may be provided.

As described above, by the present invention, in an active matrix panel formed by TFTs or the like, a circuit having a logic function such as data processing is formed by TFTs or the like on the same substrate. Therefore, without increasing a processing time of a MPU, image processing such as noise removal can be performed at a high speed. Also, miniaturization of a system can be realized.

What is claimed is:

1. A display device having at least an active matrix panel, the active matrix panel comprising:

- a first substrate;
- a second substrate arranged opposite to the first substrate;
- a liquid crystal material provided between the first and second transparent substrate;
- at least one gate line over the first substrate;
- at least one source line over the first substrate;
- at least one pixel thin film transistor formed in an intersection of the gate line and the source line;
- a gate line driver circuit comprising a first thin film transistor and connected to the gate line;
- a source line driver circuit comprising a second thin film transistor and connected to the source line; and

a processing circuit having a function of mask-processing to decrease noise of an image, the processing circuit comprising:

- a data processing circuit over the first substrate; and
- an input and output control circuit over the first substrate.

2. A display device having at least an active matrix panel, the active matrix panel comprising:

- a first substrate;
- a second substrate arranged opposite to the first substrate;
- a liquid crystal material provided between the first and second transparent substrate;
- at least one gate line over the first substrate;
- at least one source line over the first substrate;
- at least one pixel thin film transistor formed in an intersection of the gate line and the source line;
- a gate line driver circuit comprising a first thin film transistor and connected to the gate line;
- a source line driver circuit comprising a second thin film transistor and connected to the source line; and
- a processing circuit having a function of mask-processing to decrease noise of an image, the processing circuit comprising:
 - a data processing circuit comprising a third thin film transistor; and
 - an input and output control circuit comprising a fourth thin film transistor,

wherein the pixel thin film transistor, the first second, third, and fourth thin film transistors informed over the same substrate.

3. A semiconductor device comprising:

- a first substrate;
- a second substrate arranged opposite to the first substrate;
- at least one gate line over the first substrate;
- at least one source line over the first substrate;
- at least one pixel thin film transistor formed in an intersection of the gate line and the source line;
- a gate line driver circuit comprising a first thin film transistor and connected to the gate line;
- a source line driver circuit comprising a second thin film transistor and connected to the source line; and
- a processing circuit having a function of mask-processing to decrease noise of an image, the processing circuit comprising:
 - a data processing circuit over the first substrate; and
 - an input and output control circuit over the first substrate.

4. A semiconductor device comprising:

- a first substrate;
- a second substrate arranged opposite to the first substrate;
- at least one gate line over the first substrate;
- at least one source line over the first substrate;
- at least one pixel thin film transistor formed in an intersection of the gate line and the source line;
- a gate line driver circuit comprising a first thin film transistor and connected to the gate line;
- a source line driver circuit comprising a second thin film transistor and connected to the source line; and
- a processing circuit having a function of mask-processing to decrease noise of an image, the processing circuit comprising:
 - a data processing circuit comprising a third thin film transistor; and
 - an input and output control circuit comprising a fourth thin film transistor,

wherein the pixel thin film transistor, the first, second, third, and fourth thin film transistors are formed over the same substrate.

5. A semiconductor device comprising:

a first substrate;

a second substrate arranged opposite to the first substrate; at least one gate line;

at least one source line;

at least one pixel thin film transistor formed in an intersection of the gate line and the source line;

a processing circuit having a function of mask-processing to decrease noise of an image, the processing circuit comprising:

a standard clock generator circuit having a first thin film transistor; and

a counter circuit having a second thin film transistor;

a data processing circuit comprising a third thin film transistor; and

an input and output control circuit comprising a fourth thin film transistor;

wherein the pixel thin film transistor, the first, second, third, and fourth thin film transistors are formed over the same substrate,

wherein an output terminal of the standard clock generator circuit is directly connected to the counter circuit, and

wherein the counter circuit is a circuit designating an address of a pixel to be mask-processed.

6. The semiconductor device according to claim 1, wherein the data processing circuit is constructed by P-type thin film transistors.

7. The semiconductor device according to claim 1, wherein the data processing circuit is constructed by N-type thin film transistors.

8. The semiconductor device according to claim 1, wherein the data processing circuit is constructed by complementary thin film transistors.

9. The semiconductor device according to claim 1, wherein the input and output control circuit is constructed by P-type thin film transistors.

10. The semiconductor device according to claim 1, wherein the input and output control circuit is constructed by N-type thin film transistors.

11. The semiconductor device according to claim 1, wherein the input and output control circuit is constructed by complementary thin film transistors.

12. The semiconductor device according to claim 2, wherein the data processing circuit is constructed by P-type thin film transistors.

13. The semiconductor device according to claim 2, wherein the data processing circuit is constructed by N-type thin film transistors.

14. The semiconductor device according to claim 2, wherein the data processing circuit is constructed by complementary thin film transistors.

15. The semiconductor device according to claim 2, wherein the input and output control circuit is constructed by P-type thin film transistors.

16. The semiconductor device according to claim 2, wherein the input and output control circuit is constructed by N-type thin film transistors.

17. The semiconductor device according to claim 2, wherein the input and output control circuit is constructed by complementary thin film transistors.

18. The semiconductor device according to claim 3, wherein the data processing circuit is constructed by P-type thin film transistors.

19. The semiconductor device according to claim 3, wherein the data processing circuit is constructed by N-type thin film transistors.

20. The semiconductor device according to claim 3, wherein the data processing circuit is constructed by complementary thin film transistors.

21. The semiconductor device according to claim 3, wherein the input and output control circuit is constructed by P-type thin film transistors.

22. The semiconductor device according to claim 3, wherein the input and output control circuit is constructed by N-type thin film transistors.

23. The semiconductor device according to claim 3, wherein the input and output control circuit is constructed by complementary thin film transistors.

24. The semiconductor device according to claim 4, wherein the data processing circuit is constructed by P-type thin film transistors.

25. The semiconductor device according to claim 4, wherein the data processing circuit is constructed by N-type thin film transistors.

26. The semiconductor device according to claim 4, wherein the data processing circuit is constructed by complementary thin film transistors.

27. The semiconductor device according to claim 4, wherein the input and output control circuit is constructed by P-type thin film transistors.

28. The semiconductor device according to claim 4, wherein the input and output control circuit is constructed by N-type thin film transistors.

29. The semiconductor device according to claim 4, wherein the input and output control circuit is constructed by complementary thin film transistors.

30. The semiconductor device according to claim 5, wherein the data processing circuit is constructed by P-type thin film transistors.

31. The semiconductor device according to claim 5, wherein the data processing circuit is constructed by N-type thin film transistors.

32. The semiconductor device according to claim 5, wherein the data processing circuit is constructed by complementary thin film transistors.

33. The semiconductor device according to claim 5, wherein the input and output control circuit is constructed by P-type thin film transistors.

34. The semiconductor device according to claim 5, wherein the input and output control circuit is constructed by N-type thin film transistors.

35. The semiconductor device according to claim 5, wherein the input and output control circuit is constructed by complementary thin film transistors.

专利名称(译)	有源矩阵面板		
公开(公告)号	US7348971	公开(公告)日	2008-03-25
申请号	US10/914906	申请日	2004-08-10
[标]申请(专利权)人(译)	株式会社半导体能源研究所		
申请(专利权)人(译)	半导体能源研究所有限公司.		
当前申请(专利权)人(译)	半导体能源研究所有限公司.		
[标]发明人	CHIMURA HIDEHIKO		
发明人	CHIMURA, HIDEHIKO		
IPC分类号	G09G3/30 G09G5/00 G09G3/36 G09G5/20		
CPC分类号	G09G3/20 G09G3/3648 G09G5/20 G09G2300/0408 G09G2320/02		
优先权	1994270565 1994-10-07 JP		
其他公开文献	US20050012704A1		
外部链接	Espacenet USPTO		

摘要(译)

在有源矩阵面板中，在第一透明基板上形成包括多条栅极线，多条源极线和薄膜晶体管的像素矩阵。第二透明基板与第一透明基板相对地形成。液晶材料设置在第一和第二透明基板之间。栅极线驱动电路和源极线驱动电路由第一透明基板上的P型，N型，互补型薄膜晶体管（包括硅膜）等形成。此外，通过第一透明基板上的薄膜晶体管等形成用于执行掩模处理等的数据处理电路。

