



US006982769B2

(12) **United States Patent**
Ishino

(10) **Patent No.:** **US 6,982,769 B2**
(45) **Date of Patent:** **Jan. 3, 2006**

(54) **SUBSTRATE FOR LIQUID-CRYSTAL DISPLAY DEVICE AND FABRICATION METHOD THEREOF**

5,943,105 A * 8/1999 Fujikawa et al. 349/39
6,515,428 B1 * 2/2003 Yeh et al. 315/169.3

FOREIGN PATENT DOCUMENTS

(75) Inventor: **Takayuki Ishino**, Kagoshima (JP)

JP 13-147446 5/2001
KR 1998-21818 6/1998

(73) Assignee: **NEC LCD Technologies, Ltd.**, Kanagawa (JP)

* cited by examiner

(*) Notice: Subject to any disclaimer, the term of this patent is extended or adjusted under 35 U.S.C. 154(b) by 93 days.

Primary Examiner—Dung T. Nguyen
Assistant Examiner—George Y. Wang
(74) *Attorney, Agent, or Firm*—Scully, Scott, Murphy & Presser

(21) Appl. No.: **10/638,000**

(57) **ABSTRACT**

(22) Filed: **Aug. 8, 2003**

(65) **Prior Publication Data**

US 2004/0046912 A1 Mar. 11, 2004

(30) **Foreign Application Priority Data**

Aug. 9, 2002 (JP) 2002-232542

(51) **Int. Cl.**

G02F 1/136 (2006.01)

(52) **U.S. Cl.** 349/43; 349/41; 349/42; 349/52; 349/113; 349/114

(58) **Field of Classification Search** 349/43, 349/113, 114, 41, 42, 52
See application file for complete search history.

A substrate for a LCD device improves the flatness of the outermost substrate surface in the contact region for interconnecting an electrode of a switching element (e.g., a TFT) and a pixel electrode to each other in each pixel. Switching elements for respective pixels are formed on a transparent plate. Protrusions for the respective pixels are formed on the plate to protrude to a vicinity of an outermost surface of the substrate. Each protrusion raises an electrode of a corresponding switching element to the vicinity of the outermost surface in the corresponding pixel. A planarization layer forming the outermost surface is formed to cover the switching elements, the protrusions, and the electrodes of the elements in all the pixels. Pixel electrodes for the respective pixels are formed on the outermost surface. Each pixel electrode contacts the corresponding electrode of the element in the vicinity of the outermost surface.

(56) **References Cited**

U.S. PATENT DOCUMENTS

5,818,550 A * 10/1998 Kadota et al. 349/43

19 Claims, 8 Drawing Sheets

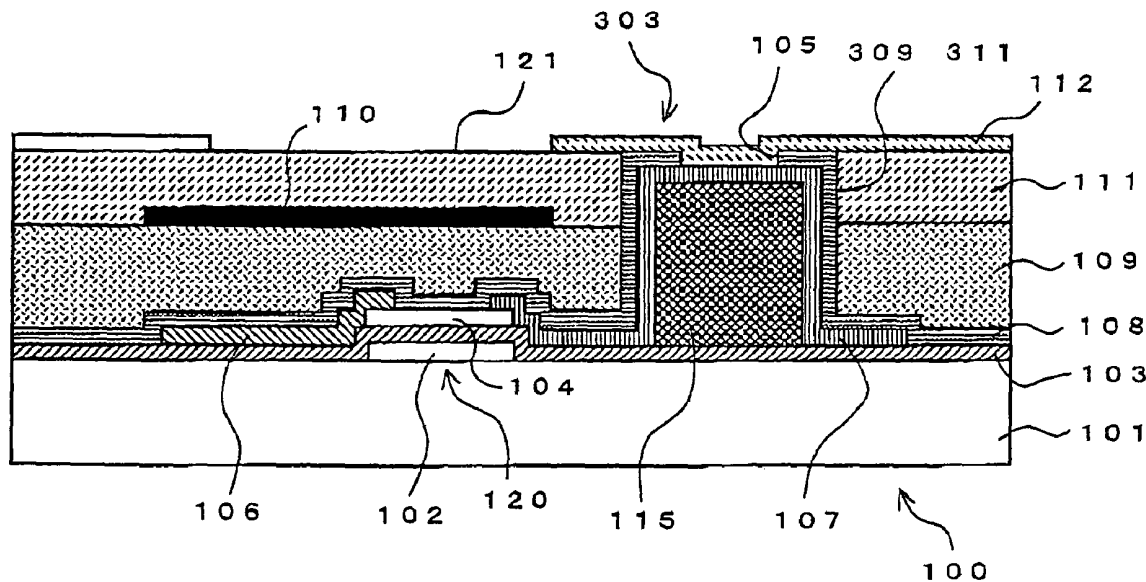

FIG. 1
PRIOR ART

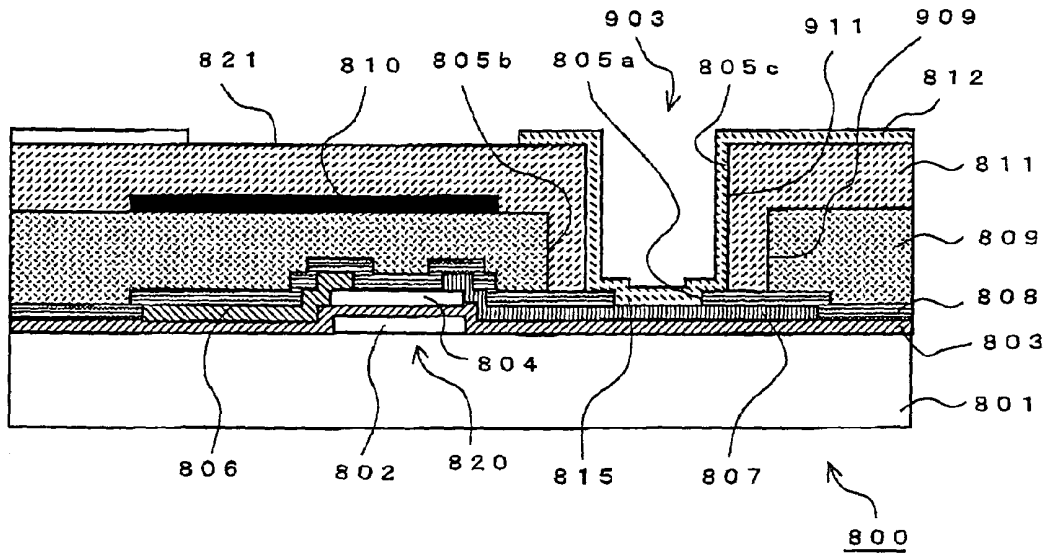

FIG. 2
PRIOR ART

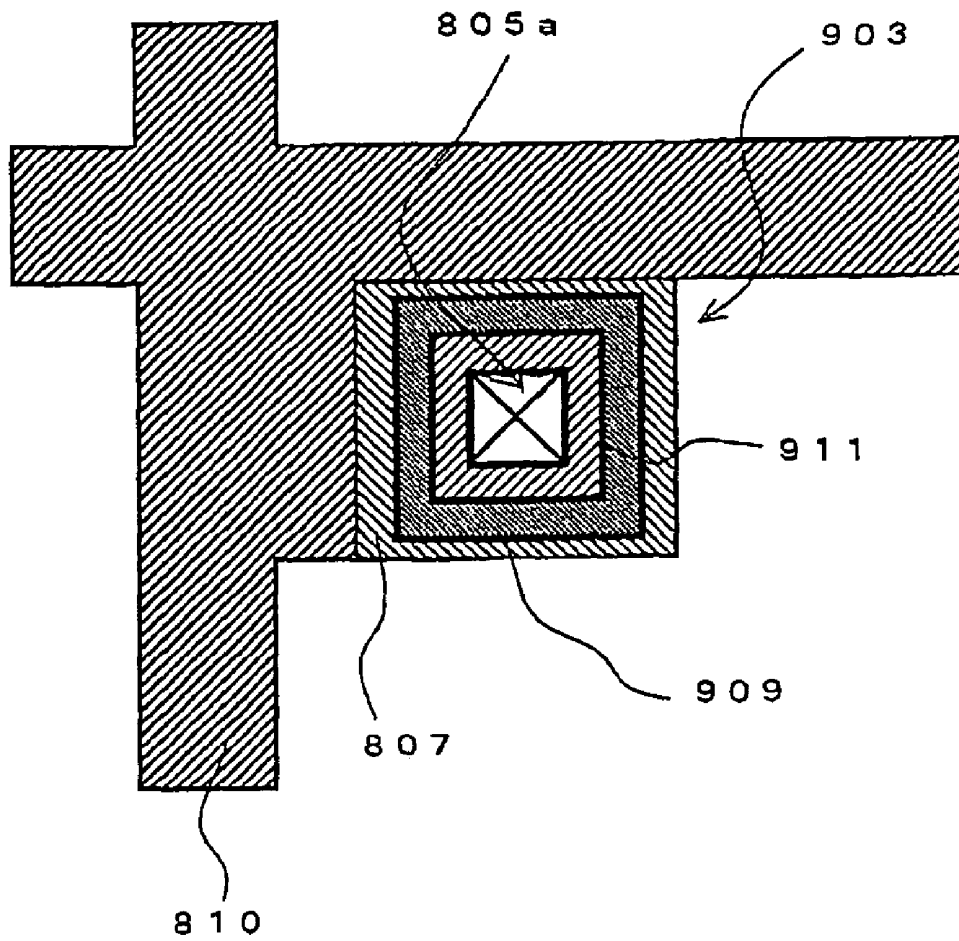

FIG. 4

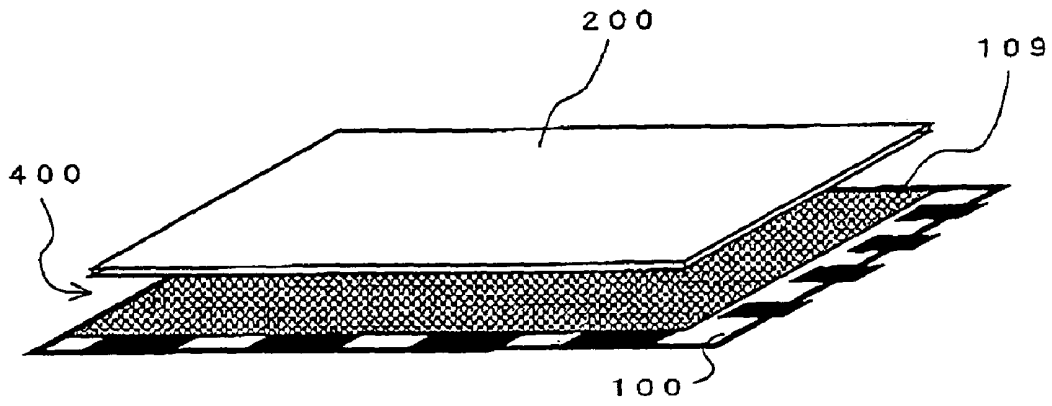

FIG. 5

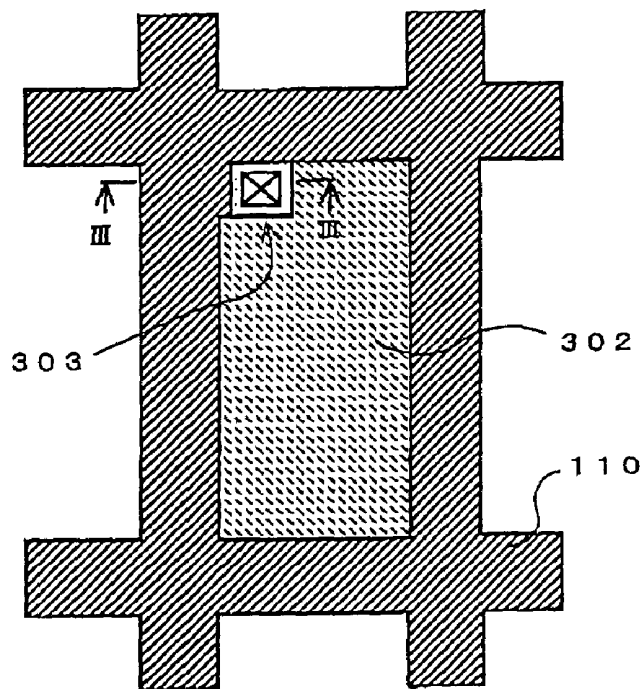

FIG. 6

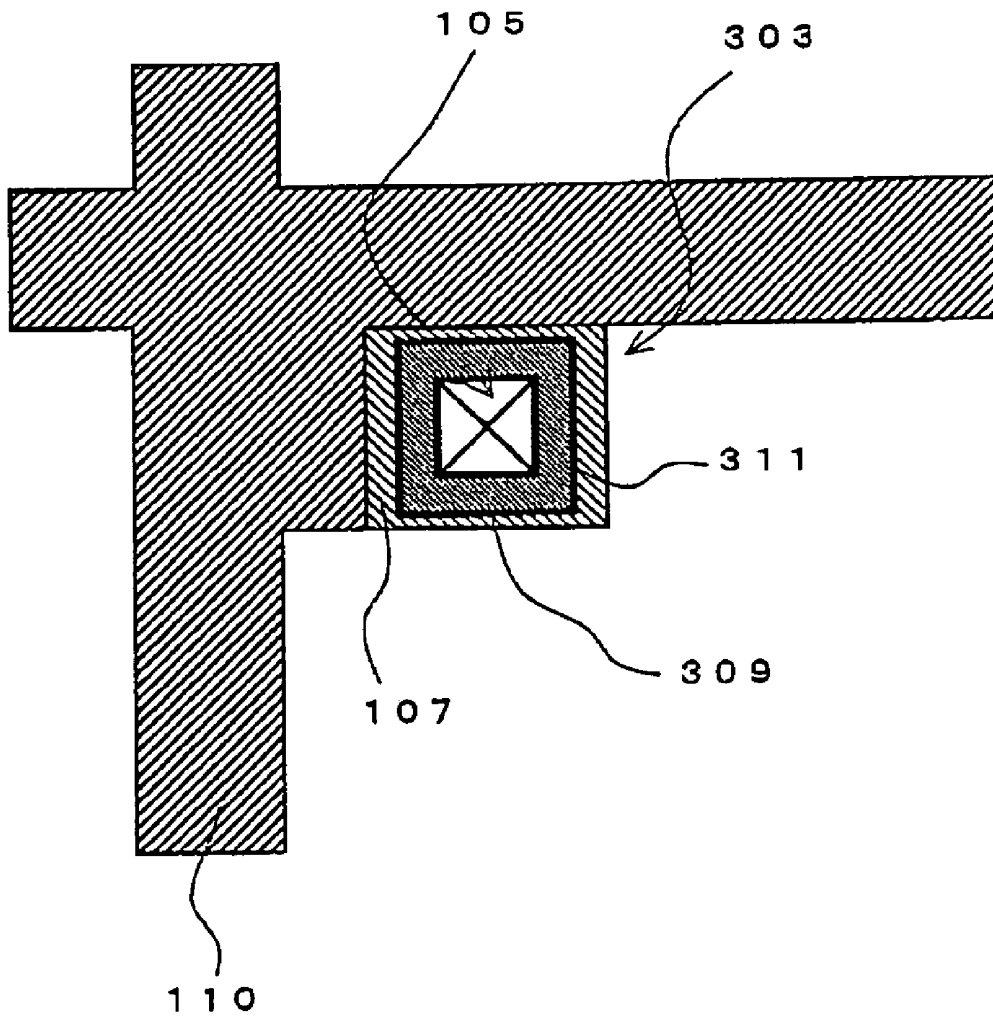

FIG. 7A

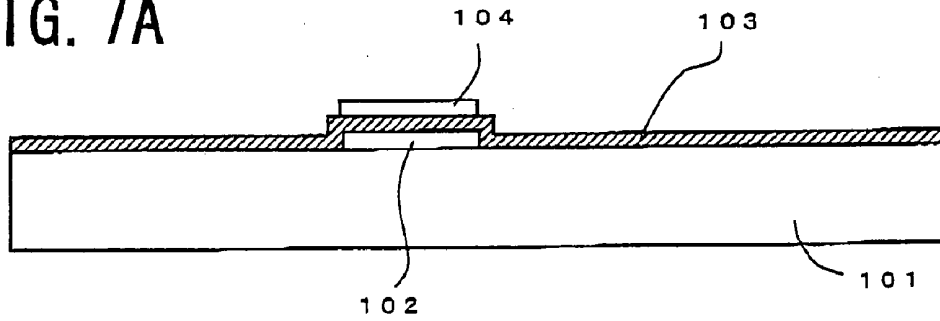

FIG. 7B

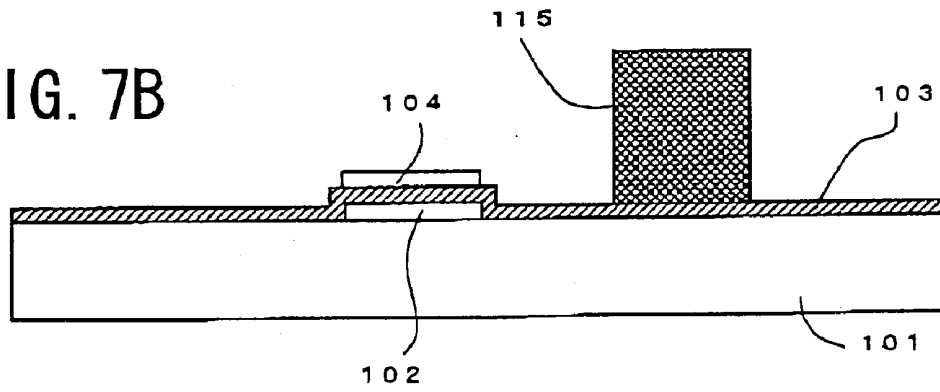

FIG. 7C

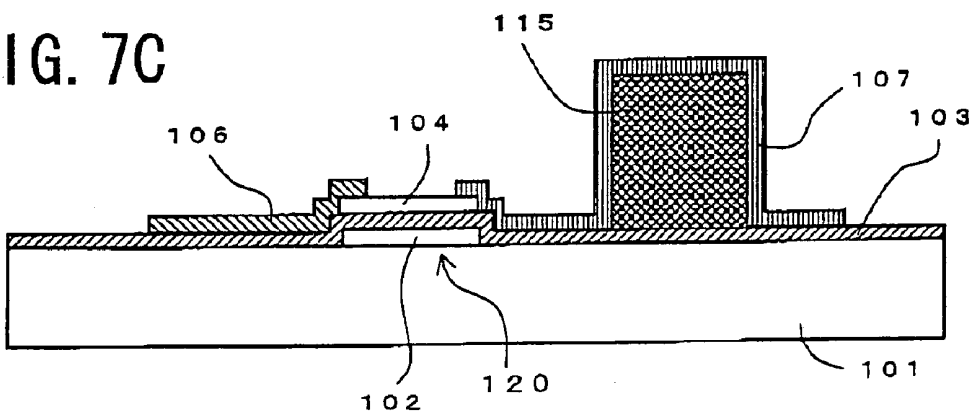

FIG. 8A

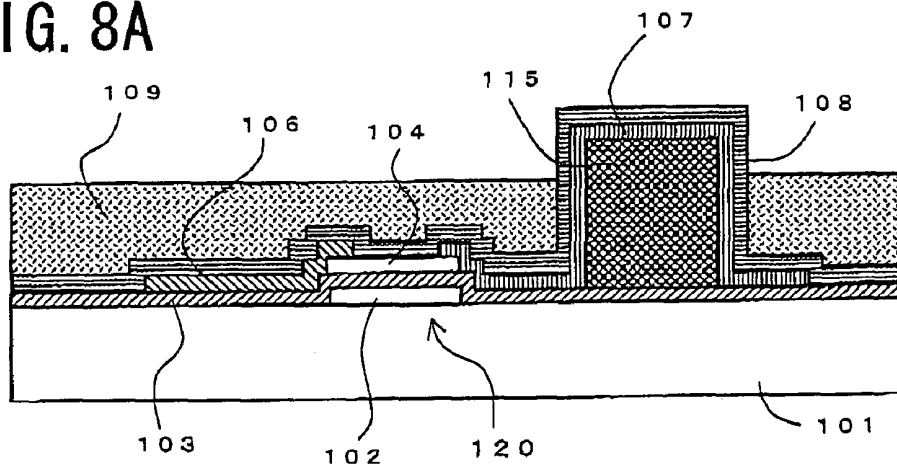

FIG. 8B

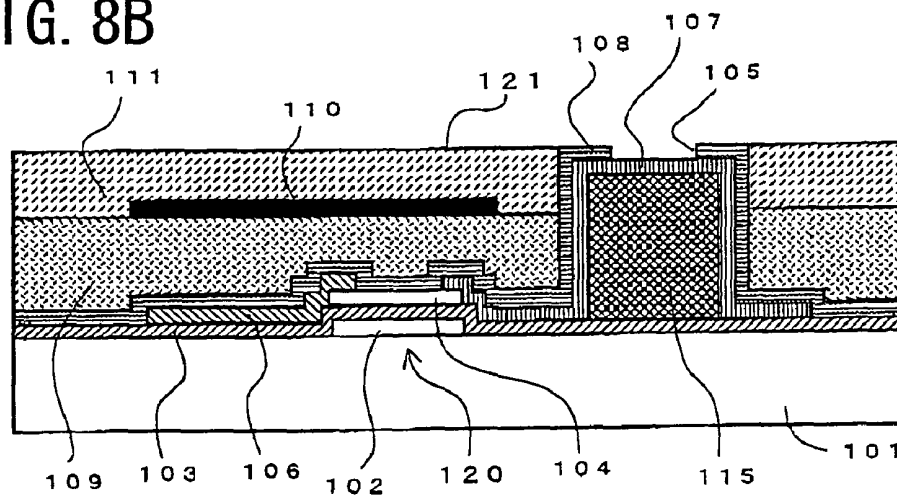

FIG. 8C

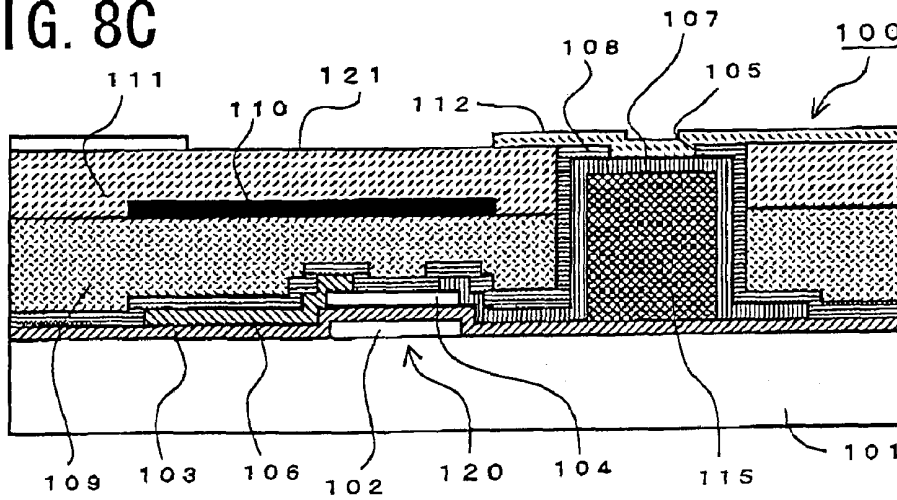

FIG. 9A

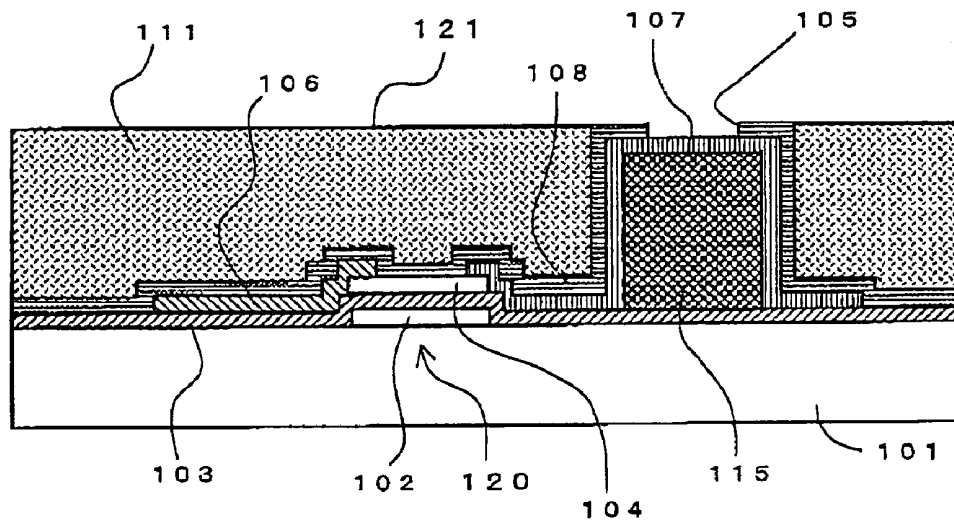
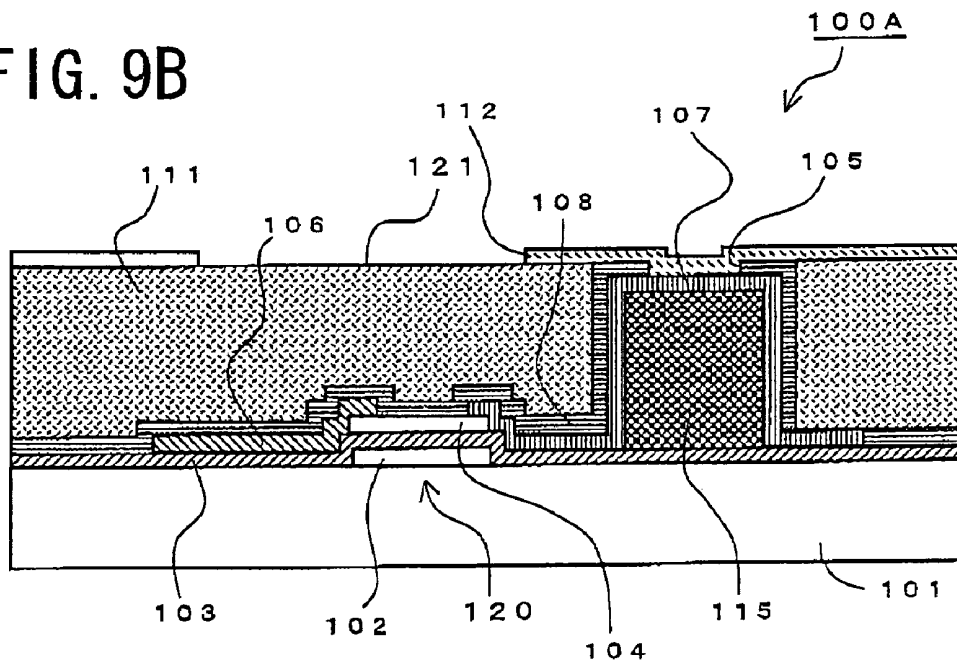

FIG. 9B



SUBSTRATE FOR LIQUID-CRYSTAL DISPLAY DEVICE AND FABRICATION METHOD THEREOF

BACKGROUND OF THE INVENTION

1. Field of the Invention

The present invention relates to a liquid-crystal display (LCD) device. More particularly, the invention relates to a substrate for a LCD device, a fabrication method thereof, and a LCD device using the substrate.

2. Description of the Related Art

As known well, the LCD device comprises a TFT (Thin-Film Transistor) array substrate on which TFTs are arranged at the respective intersections of gate electrodes and data electrodes formed in such a way as to form an array, an opposite substrate on which an opposite electrode or electrodes are formed, and a liquid crystal layer formed between these two substrates.

FIG. 1 shows an example of the pixel structure of a prior-art TFT array substrate **800**. Although a plurality of pixels is actually arranged on the substrate, one pixel will be explained here for the sake of simplification of description.

This substrate **800** has a color filter **809** formed by an organic layer, which is a so-called a "color-filter-on (CF-on) TFT substrate". With the CF-on-TFT substrate, the color filter **809** is provided on the TFT substrate **800** and therefore, the gap between the TFT array and the color filter **809** is approximately eliminated. As a result, there is an advantage that a high-resolution LCD device is realizable by progressing the miniaturization of the respective pixels while suppressing the reduction of the aperture ratio through setting the line width of the black matrix (BM) at its minimum.

With the CF-on-TFT array substrate **800**, as shown in FIG. 1, a gate electrode **802** is formed on the transparent plate **801**. The gate electrode **802** is covered with an inorganic gate dielectric layer **803**, formed on the plate **801**. On the gate dielectric layer **803**, a patterned amorphous silicon (a-Si) layer **804** is formed in such a way as to overlap with the gate electrode **802**. A drain electrode **806** and a source electrode **807** are formed at the opposite ends of the a-Si layer **804**, respectively. The gate electrode **802**, the gate dielectric layer **803**, the a-Si layer **804**, and the drain and source electrodes **806** and **807** constitute a TFT **820**.

The TFT **820** is covered with an inorganic interlayer dielectric layer (which serves as a passivation layer) **808**. The layer **808** has a contact hole **805a** that exposes partially the underlying source electrode **807**. The hole **805a** is rectangular in horizontal cross section.

On the interlayer dielectric layer **808**, a patterned color filter (i.e., a color layer) **809** is formed. The layer **808** has a contact hole **805b** that exposes partially the underlying source electrode **807**. The hole **805b** is rectangular in horizontal cross section and is larger than the contact hole **805a** of the interlayer dielectric layer **808**.

On the color filter **809**, a patterned light-shielding layer **810** is selectively formed at a location that overlaps with the TFT **820**. The layer **810** has a function of preventing the external light from irradiating to the a-Si layer **804** and the drain electrode **806** of the TFT **820**.

Moreover, an organic transparent interlayer dielectric layer **811** is formed on the color filter **809** to cover the light-shielding layer **810**. The layer **811** has a contact hole **805c** at a location that overlaps with the contact holes **805a** and **805b**, thereby partially exposing the underlying source

electrode **807**. The hole **805c** is rectangular in horizontal cross section. The hole **805c** is larger than the hole **805a** but smaller than the hole **805b**.

On the interlayer dielectric layer **811**, in other words, on the outermost surface **821** of the TFT array substrate **800**, a pixel electrode **812** is formed. The pixel electrode **812** is extended along the inner wall of the contact hole **805c** of the layer **811** and contacted with the source electrode **807** by way of the contact hole **805a** of the interlayer dielectric layer **808**. In this way, the pixel electrode **812** and the source electrode **807** are electrically connected to each other.

FIG. 2 shows a plan view showing the layout in the contact region **903** (i.e., in the neighborhood of the contact hole **805a**) of the prior-art CF-on-TFT substrate **900** of FIG. 1.

The colored resist materials for the color filter **809** are less in chemical resistance. Therefore, if the resist materials are kept exposed during the process steps, partial loss of the filter **809** will occur through a subsequent process step or steps. Therefore, the structure of FIG. 1 is adopted in order that the organic interlayer dielectric layer **811** surely covers not only the surface of the filter **809** but also the inner wall surface of the hole **805b**. In other words, as shown in FIG. 2, the boundary **909** of the color filter **809** on the side of the hole **805b** and the boundary **911** of the dielectric layer **811** on the side of the hole **805c** are horizontally shifted to each other (i.e., the boundary **909** is located outside the boundary **911**). Thus, it is ensured that the filter **809** is covered with the layer **811**. This structure may be called a "multiple contact-hole structure".

It is popular that the thickness of the organic interlayer dielectric layer **811** is 2 to 3 μm (i.e., 2000 to 3000 nm) and the thickness of the inorganic interlayer dielectric layer **808** is several hundreds nanometers (nm). The color filter **809** with approximately the same thickness as the layer **811** is located between these dielectric layers **811** and **808**. Therefore, with the prior-art TFT array substrate **800**, the contact hole **805c** of the layer **811** will cause a large and deep step (e.g., the height difference or depth is 4 to 6 μm). As a result, a deep depression is formed for each pixel on the outermost surface **821** of the substrate **800**, as shown in FIG. 1. These depressions will disturb the orientation of the liquid crystal confined in the liquid crystal layer and thus, there arises a problem that the control of transmitting light is difficult to thereby induce leak of light. This means that the display quality degrades due to contrast reduction.

To avoid the leak of light, the source electrode **807** is typically utilized. Specifically, the shape and size of the electrode **807** are determined in such a way as to completely prevent the leak of light. In this case, however, there arises another problem that the aperture ratio will lower and the luminance of the LCD panel will deteriorate.

In particular, to form the multiple contact-hole structure (i.e., the contact region **903**) as shown in FIG. 1, appropriate margins need to be provided in the respective process steps of forming the contact holes **805a**, **805b**, and **805c**. Therefore, the hole **805b** located at the horizontally outermost position will be considerably large in size, in other words, the contact region **903** (i.e., the depression shown in FIG. 1) will occupy a considerable wide area. As a result, the size of the source electrode **807** needs to be considerably wider and the aperture ratio will lower conspicuously.

SUMMARY OF THE INVENTION

The present invention was created through consideration about the above-described problems.

Accordingly, an object of the present invention is to provide a substrate for a LCD device that improves the flatness of the outermost substrate surface in the contact region for interconnecting an electrode of a switching element (e.g., a TFT) and a pixel electrode to each other in each pixel, a method of fabricating the substrate, and a LCD device using the substrate.

Another object of the present invention is to provide a substrate for a LCD device that reduces the area of the contact region for interconnecting an electrode of a switching element and a pixel electrode to each other in each pixel, a method of fabricating the substrate, and a LCD device using the substrate.

Still another object of the present invention is to provide a substrate for a LCD device that effectively suppresses the contrast lowering and the aperture ratio reduction with a simple structure or method, a method of fabricating the substrate, and a LCD device using the substrate.

The above objects together with others not specifically mentioned will become clear to those skilled in the art from the following description.

According to a first aspect of the present invention, a substrate for a LCD device is provided, which comprises:

- a transparent plate;
- switching elements for respective pixels, formed on the plate;
- protrusions for the respective pixels, formed on the plate in such a way as to protrude to a vicinity of an outermost surface of the substrate;
- each of the protrusions raising an electrode of a corresponding one of the switching elements to the vicinity of the outermost surface in a corresponding one of the pixels;
- a planarization layer formed in such a way as to cover the switching elements, the protrusions, and the electrodes of the elements in all the pixels, a surface of the planarization layer forming the outermost surface;
- pixel electrodes for the respective pixels, formed on the outermost surface; and
- each of the pixel electrodes being contacted with a corresponding one of the electrodes of the switching elements in the vicinity of the outermost surface.

With the substrate according to the first aspect of the present invention, the protrusions for the respective pixels are formed on the transparent plate in such a way as to protrude to the vicinity of the outermost surface of the substrate. Each of the protrusions raises the electrode of a corresponding one of the switching elements to the vicinity of the outermost surface in a corresponding one of the pixels. The outermost surface is formed by the surface of the planarization layer that is formed in such a way as to cover the switching elements, the protrusions, and the electrodes of the elements in all the pixels. Each of the pixel electrodes formed on the outermost surface is contacted with a corresponding one of the electrodes of the switching elements in the vicinity of the outermost surface.

Therefore, a deep contact hole is unnecessary in a contact region for interconnecting one of the electrodes of the switching elements with a corresponding one of the pixel electrodes. As a result, the flatness of the outermost surface of the substrate is improved in the contact region. This leads to suppression of contrast lowering of the LCD device.

Moreover, since no deep contact hole is necessary and the flatness of the outermost surface of the substrate is improved in the above-described contact regions, leakage of light will not occur in the contact regions. This means that the area expansion of the electrode of each switching element is

unnecessary. Thus, the area of each contact region can be reduced, which suppresses the reduction of the aperture ratio.

In this way, with the substrate according to the first aspect of the invention, the contrast lowering and the aperture ratio reduction are suppressed with a simple structure.

In a preferred embodiment of the substrate according to the first aspect, the switching elements are TFTs, and the electrodes of the switching elements are source electrodes or drain electrodes of the TFTs.

In another preferred embodiment of the substrate according to the first aspect, each of the electrodes of the switching elements is extended along top and side faces of a corresponding one of the protrusions.

In still another preferred embodiment of the substrate according to the first aspect, each of the electrodes of the switching elements is extended along top and side faces of a corresponding one of the protrusions, and is contacted with a corresponding one of the pixel electrodes at a top of a corresponding one of the protrusions.

In a further preferred embodiment of the substrate according to the first aspect, the planarization layer includes a transparent organic interlayer dielectric sublayer.

In a still further preferred embodiment of the substrate according to the first aspect, a color filter is additionally provided. A distance between a top of each of the protrusions and the outermost surface is shorter than a distance between a top of the color filter and the outermost surface.

In a still further preferred embodiment of the substrate according to the first aspect, a color filter is additionally provided. A boundary between the filter and each of the protrusions is superposed on a boundary between the planarization layer and the said protrusion.

According to a second aspect of the present invention, a method of fabricating a substrate for a LCD device is provided, which comprises the steps of:

- forming protrusions for respective pixels on a transparent plate in such a way as to protrude to a vicinity of an outermost surface of the substrate;
- forming switching elements for the respective pixels in such a way that electrodes of the elements are raised by the corresponding protrusions to the vicinity of the outermost surface;
- forming a planarization layer in such a way as to cover the switching elements, the protrusions, and the electrodes of the elements in all the pixels, a surface of the planarization layer forming the outermost surface; and
- forming pixel electrodes for the respective pixels on the outermost surface;
- wherein each of the pixel electrodes is contacted with a corresponding one of the electrodes of the switching elements in the vicinity of the outermost surface.

With the method according to the second aspect of the present invention, the protrusions for the respective pixels are formed on the transparent plate in such a way as to protrude to the vicinity of the outermost surface of the substrate and thereafter, the switching elements are formed in such a way that the electrodes of the elements are raised by the corresponding protrusions to the vicinity of the outermost surface. Following this, the planarization layer is formed in such a way as to cover the switching elements, the protrusions, and the electrodes of the elements in all the pixels. Subsequently, the pixel electrodes are formed on the outermost surface, where each of the pixel electrodes is contacted with the corresponding one of the electrodes of the switching elements in the vicinity of the outermost surface.

Accordingly, a deep contact hole is unnecessary in a contact region for interconnecting one of the electrodes of the switching elements with a corresponding one of the pixel electrodes. As a result, the flatness of the outermost surface of the substrate is improved in the contact regions. This leads to suppression of contrast lowering of the LCD device.

Moreover, since no deep contact hole is necessary and the flatness of the outermost surface of the substrate is improved in the above-described contact regions, leakage of light will not occur in the contact regions. This means that the area expansion of the electrode of each switching element is unnecessary. Thus, the area of each contact region can be reduced, which suppresses the reduction of the aperture ratio.

In this way, with the method according to the second aspect of the invention, the contrast lowering and the aperture ratio reduction are suppressed with a simple structure.

In a preferred embodiment of the method according to the second aspect, the switching elements are TFTs, and the electrodes of the switching elements are source electrodes or drain electrodes of the TFTs.

In another preferred embodiment of the method according to the second aspect, each of the electrodes of the switching elements is formed to extend along top and side faces of a corresponding one of the protrusions.

In still another preferred embodiment of the method according to the second aspect, each of the electrodes of the switching elements is formed to extend along top and side faces of a corresponding one of the protrusions and to contact a corresponding one of the pixel electrodes at a top of a corresponding one of the protrusions.

In a further preferred embodiment of the method according to the second aspect, the planarization layer includes a transparent organic interlayer dielectric sublayer.

In a still further preferred embodiment of the method according to the second aspect, a step of forming a color filter is additionally provided. A distance between a top of each of the protrusions and the outermost surface is shorter than a distance between a top of the color filter and the outermost surface.

In a still further preferred embodiment of the method according to the second aspect, a step of forming a color filter is additionally provided. A boundary between the filter and each of the protrusions is superposed on a boundary between the planarization layer and the said protrusion.

According to a third aspect of the present invention, a LCD device is provided, which comprises:

- a first substrate;
- a second substrate coupled with the first substrate to be opposite to each other at a gap; and
- a liquid-crystal layer formed in the gap.

The first substrate comprises:

- a transparent plate;
- switching elements for respective pixels, formed on the plate;

protrusions for the respective pixels, formed on the plate in such a way as to protrude to a vicinity of an outermost surface of the substrate;

each of the protrusions raising an electrode of a corresponding one of the switching elements to the vicinity of the outermost surface in a corresponding one of the pixels;

a planarization layer formed in such a way as to cover the switching elements, the protrusions, and the electrodes of the elements in all the pixels, a surface of the planarization layer forming the outermost surface;

pixel electrodes for the respective pixels, formed on the outermost surface; and

each of the pixel electrodes being contacted with a corresponding one of the electrodes of the switching elements in the vicinity of the outermost surface.

With the device according to the third aspect of the present invention, the first substrate has the same structure as the substrate according to the first aspect and therefore, the same advantages as those of the substrate according to the first aspect are obtainable.

BRIEF DESCRIPTION OF THE DRAWINGS

In order that the present invention may be readily carried into effect, it will now be described with reference to the accompanying drawings.

FIG. 1 is a schematic, partial cross-sectional view showing an example of the pixel structure of a prior-art CF-on-TFT array substrate.

FIG. 2 is a plan view showing the layout in the contact region of the prior-art substrate of FIG. 1.

FIG. 3 is a schematic, partial cross-sectional view along the line III—III in FIG. 5, showing the pixel structure of a CF-on-TFT array substrate according to a first embodiment of the invention.

FIG. 4 is a schematic perspective view showing the rough structure of a LCD device using the array substrate according to the first embodiment of FIG. 3.

FIG. 5 is a schematic plan view showing the layout in the pixel formed on the substrate according to the first embodiment of FIG. 3.

FIG. 6 is a plan view showing the layout in the contact region of the substrate according to the first embodiment of FIG. 3.

FIGS. 7A to 7C are partial schematic cross-sectional views of the substrate according to the first embodiment of FIG. 3, respectively, which show the process steps of its fabrication method.

FIGS. 8A to 8C are partial schematic cross-sectional views of the substrate according to the first embodiment of FIG. 3, respectively, which show the process steps of its fabrication method subsequent to the step of FIG. 7C.

FIGS. 9A and 9B are partial schematic cross-sectional views of a TFT array substrate according to a second embodiment of FIG. 3, respectively, which show the process steps of its fabrication method.

DETAILED DESCRIPTION OF THE PREFERRED EMBODIMENTS

Preferred embodiments of the present invention will be described in detail below while referring to the drawings attached.

First Embodiment

A substrate **100** for a LCD device according to a first embodiment of the invention has the structure shown in FIGS. 3 and 5.

The substrate **100** according to the first embodiment, which is a CF-on-TFT array substrate on which a color filter is mounted, comprises gate electrodes and data electrodes (both not shown) arranged in a matrix array, and TFTs arranged at the respective intersections of the gate and data electrodes. Although a plurality of pixels is actually arranged on the substrate **100**, one pixel will be explained here for the sake of simplification of description because all the pixels have the same structure.

With the CF-on-TFT array substrate **100**, as shown in FIG. 3, a gate electrode **102** is formed on a transparent plate **101**. The gate electrode **102** is covered with an inorganic gate dielectric layer **103** formed on the plate **101**. On the gate dielectric layer **103**, a patterned a-Si layer **104** is formed in such a way as to overlap with the gate electrode **102**. On the gate dielectric layer **103**, a protrusion **115** with a specific shape is formed at a location overlapping with a pixel electrode **112**. This protrusion **115** is to raise the approximately middle part (i.e., the contacting part with the pixel electrode **112**) of a source electrode **107** to a vicinity of the outermost surface **121** of the substrate **100**. The protrusion **115** does not overlap with the a-Si layer **104**.

The protrusion **115** is formed in such a way that the top face of the protrusion **115** is located near the outermost surface **121**. In other words, the protrusion **115** reaches the vicinity of the surface **121**. The shape of the horizontal cross-section of the protrusion **115** is rectangular. The plan shape of the source electrode **107** is rectangular as well. However, the horizontal cross-section of the protrusion **115** is narrower than the plan shape of the source electrode **107**. Thus, the whole protrusion **115** is covered with the source electrode **107**. The protrusion **115** is formed by patterning a layer of an organic resist material.

A drain electrode **106** and a source electrode **107** are formed at the opposite ends of the a-Si layer **104**, respectively. The source electrode **107** is overlapped with the protrusion **115**. As described previously, the approximately middle part of the source electrode **107** is raised by the protrusion **115** to the vicinity of the outermost surface **121**. The source electrode **107** is formed to extend along the whole top face and the whole side face of the protrusion **115**. In other words, the source electrode **107** is contacted with the whole top face and the whole side face of the protrusion **115** and covers the same. Therefore, the protrusion **115** is entirely covered with the source electrode **107** and is unable to be seen from the side of the outermost surface **121**.

The gate electrode **102**, the gate dielectric layer **103**, the a-Si layer **104**, and the drain and source electrodes **106** and **107** constitute a TFT **120**. The gate dielectric layer **103**, which is formed to cover the whole plate **101**, is commonly used by all the TFTs **120** arranged on the plate **101**.

The TFT **120** is covered with an inorganic interlayer dielectric layer (which serves as a passivation layer) **108**. Typically, the layer **108** is several hundreds nanometers (nm) in thickness. The layer **108** has a contact hole **105** formed over the top of the protrusion **115**. The hole **105**, which is rectangular in horizontal cross section, exposes partially the underlying source electrode **107**. Since the size of the hole **105** is smaller than the area of the top of the protrusion **115**, only a part of the source electrode **107** is exposed on the top of the protrusion **115**.

On the interlayer dielectric layer **108**, a patterned color filter (i.e., a color layer) **109** is formed. The thickness of the filter **109** is determined in such a way that the surface of the filter **109** is lower than the top of the protrusion **115**. Thus, the top of the protrusion **115** protrudes upward from the filter **109**, in other words, the top of the protrusion **115** is not covered with the filter **109**.

On the color filter **109**, a patterned light-shielding layer **110** is selectively formed at a location that overlaps with the TFT **120**. The layer **110** has a function of preventing the external light from irradiating to the a-Si layer **104** and the drain electrode **106** of the TFT **120**.

Moreover, an organic transparent interlayer dielectric layer **111** is formed on the color filter **109** to cover the light-shielding layer **110**. Typically, the layer **111** has a

thickness of 2 to 3 μm . The thickness of the layer **111** is determined in such that the surface of the layer **111** is in the same level as the top of the interlayer dielectric layer **108** on the top of the protrusion **115**. Thus, no contact hole is formed in the interlayer dielectric layer **111** and at the same time, the contact hole **105** of the layer **108** is exposed from the layer **111** on the top of the protrusion **105**. Because of this, the part of the underlying source electrode **107** is exposed from the layer **111** through the hole **105**. Since the hole **105** is formed to penetrate through the thin interlayer dielectric layer **108**, the hole **105** is very shallow.

On the surface of the interlayer dielectric layer **111**, in other words, on the outermost surface **121** of the TFT array substrate **100**, a pixel electrode **112** is formed. The pixel electrode **112** is contacted with the source electrode **107** on the top of the protrusion **115** by way of the contact hole **105** of the interlayer dielectric layer **108**. In this way, the pixel electrode **112** and the source electrode **107** are electrically connected to each other.

FIG. 5 shows a plan view showing the layout in the contact region **303** (i.e., in the neighborhood of the contact hole **105**) of the CF-on-TFT substrate **100** according to the first embodiment of FIG. 3. As shown in FIG. 5, the light-shielding layer **110**, which is patterned to be lattice-shaped in its plan view, has an approximately rectangular transmission region **302** corresponding to each pixel. The transmission region **302** and a corresponding contact region **303** thereto are formed for each pixel.

FIG. 6 shows an enlarged plan view showing the layout near the contact region **303** of the substrate **100** according to the first embodiment. As shown in FIG. 6, in the contact region **303** for interconnecting the source electrode **107** and the pixel electrode **112**, the boundary **309** of the color filter **109** on the side of the protrusion **115** and the boundary **311** of the organic interlayer dielectric layer **111** on the side of the protrusion **115** are contacted with the vertically-extending part of inorganic interlayer dielectric layer **108**. Thus, these two boundaries **309** and **311** are superposed to each other, in other words, the boundaries **309** and **311** are vertically aligned, when observed from the side of the outermost surface **121**. Therefore, the area of the contact region **303** in the first embodiment of the invention can be reduced, thereby improving the aperture ratio and luminance of the LCD panel. This is unlike the prior-art substrate **800** shown in FIG. 1 where the contact region **903** needs to be considerably wide due to the multiple contact-hole structure of the holes **805a**, **805b**, and **805c**.

With the CF-on-TFT array substrate **100** according to the first embodiment of the invention, as explained above, the protrusions **115** for the respective pixels are formed on the transparent plate **101** in such a way as to protrude to the vicinity of the outermost surface **121** of the substrate **100**. Each of the protrusions **115** raises the source electrode **107** of a corresponding one of the TFTs **120** (i.e., the switching elements) to the vicinity of the surface **121** in a corresponding one of the pixels. The outermost surface **121** is formed by the surface of the transparent organic interlayer dielectric layer (i.e., the surface of the planarization layer) **111** that is formed in such a way as to cover the TFTs **120**, the protrusions **115**, and the source electrodes **107** in all the pixels. Each of the pixel electrodes **112** formed on the outermost surface **121** is contacted with a corresponding one of the source electrodes **107** in the vicinity of the surface **121** by way of the contact hole **105**.

Therefore, no deep contact hole is necessary in the contact region **303** for interconnecting one of the source electrodes **107** with a corresponding one of the pixel electrodes **112**. As

a result, the flatness of the outermost surface **121** is vastly improved in the contact region **303**, thereby making the whole surface **121** approximately flat. This eliminates the disturbance of the orientation of the liquid crystal molecules used, which suppresses the contrast lowering of the LCD device.

Moreover, since no deep contact hole is necessary and the flatness of the outermost surface **121** is vastly improved in the contact region **303**, leakage of light will not occur in the region **303**. This means that the area expansion of the source electrode **107** is unnecessary. Thus, the area of the region **303** can be reduced, which suppresses the reduction of the aperture ratio of the LCD device.

In this way, with the substrate **100** according to the first embodiment, the contrast lowering and the aperture ratio reduction are suppressed with a simple structure and as a result, the quality of images is advanced.

Next, a method of fabricating the substrate **100** according to the first embodiment is explained below.

In summary, the gate electrodes **102** for the respective pixels are first formed on the transparent plate **101** and then, the inorganic gate dielectric layer **103** is formed thereon. Next, the patterned a-Si layers **104** are formed on the layer **103**. The protrusions **115** are formed at the respective positions that will become the contact regions **303** for the pixels and then, the drain electrodes **106** and the source electrodes **107** are formed for the respective pixels. After the inorganic interlayer dielectric layer **108** is formed, the patterned color filter **109** is formed on the layer **108** by using colored resist materials. On the color filter **109**, the patterned light-shielding layer **110** is formed by using a black resist material. After forming the transparent organic interlayer dielectric layer **111** to cover the light-shielding layer **110**, the contact holes **105** for interconnecting the source electrodes **107** with the corresponding pixel electrodes **112** are formed to penetrate the layer **108**. Finally, a transparent conductive layer is formed on the surface of the layer **111** (i.e., the outermost surface **121**) and patterned, thereby forming the pixel electrodes **112**.

The respective process steps of the fabrication method will be explained in detail below with reference to FIGS. 7A to 7C and FIGS. 8A to 8C.

First, as shown in FIG. 7A, on the surface of the transparent plate **101**, the gate electrodes **102** are formed for the respective pixels. The plate **110** may be made of any rigid, transparent material if it is not denatured and deformed through the heating process or processes contained in the fabrication process sequence. For example, glass, quartz or plastic may be used. Glass is typically used for this purpose. The gate electrodes **102** are usually united with the gate lines. A layer of metal (e.g., Cr or Al) for the gate electrodes **102** (and gate lines) is formed on the plate **101** by sputtering or the like. The layer of metal is then patterned by photolithography and etching processes to have a specific shape, resulting in the gate electrodes **102** (and gate lines).

Subsequently, on the whole plate **101**, the inorganic gate dielectric layer **103** is formed to cover the gate electrodes **102**. The layer **103** is typically made of silicon dioxide (SiO₂). On the gate dielectric layer **103**, the patterned a-Si layers **104** are formed to cover the respective gate electrodes **102**. An a-Si layer is formed by a CVD (Chemical Vapor Deposition) process or the like and then, it is patterned by photolithography and etching processes, resulting in the a-Si layers **104**. The state at this stage is shown in FIG. 7A.

On the gate dielectric layer **103**, the protrusions **115** are formed for the respective pixels, as shown in FIG. 7B. The height of each protrusion **115** is set to be approximately

equal to the sum of the thicknesses of the inorganic interlayer dielectric layer **108**, the color filter **109**, and the organic interlayer dielectric layer **111**. For example, the height of each protrusion **115** is set at approximately 2 to 3 μm. The material for the protrusions **115** is optionally chosen if it is able to form the protrusions **115** having such the height and shape and is able to keep the same. In the first embodiment, a photosensitive organic resist material is used for the protrusions **115**. Actually, this photosensitive organic resist material is coated to form a layer with a desired thickness on the gate dielectric layer **103** and then, it is exposed to light with a mask having a desired pattern and developed. Thus, the protrusions **115** each having a specific three-dimensional shape are formed, as shown in FIG. 7B. At this time, to prevent the protrusions **115** from being vertically tapered (in other words, to prevent the protrusions **115** from being relatively thick at their tops and relatively thin at their bottoms), it is preferred that an intermediate bake process is additionally carried out for the layer of the organic resist material. In this case, thereafter, a main sintering process is conducted for the said layer. The intermediate bake process is preferably carried out at a temperature of 100 to 150° C. for approximately two to five minutes. The main sintering process is preferably conducted at a temperature of 200 to 230° C. for approximately one hour.

Following the process step of forming the protrusions **115**, as shown in FIG. 7C, the drain and source electrodes **106** and **107** are formed on the gate dielectric layer **103** for the respective pixels. Similar to the prior-art substrate **800**, each of the drain electrodes **106** is contacted with the corresponding a-Si layer **104** at its one end and the remainder thereof is placed on the layer **103**. Unlike this, each of the source electrodes **107** is contacted with the corresponding a-Si layer **104** at its one end and the remainder thereof is formed to entirely cover the corresponding protrusion **115**. The source electrode **107** covers the whole top face and the whole side face of the protrusion **115**. The remainder of the source electrode **107** is placed on the layer **103**. A layer of metal (e.g., Cr or Al) used for the drain and gate electrodes **106** and **107** is formed by sputtering or the like. The layer of metal is then patterned by photolithography and etching processes to have a specific shape, resulting in the electrodes **106** and **107**. In the first embodiment, an organic resist material is used for making the protrusions **115** and therefore, the layer of metal needs to be formed at the highest usable temperature of the organic resist material (i.e., 230° C.) or lower. The state at this stage is shown in FIG. 7C.

Subsequently, as shown in FIG. 8A, the inorganic interlayer dielectric layer **108** is formed to cover the drain and source electrodes **106** and **107** and the protrusions **115**. Since the layer **108** is as thin as several hundreds nanometers (nm), the layer **108** extends along the uneven surface formed by the electrodes **106** and **107** and the protrusions **115**. In other words, the surface of the layer **108** is uneven according to the reflection of the said uneven surface. The layer **108** covers the whole side face and the whole top face of each protrusion **115**. As the layer **108**, a silicon dioxide (SiO₂), silicon nitride (SiN_x) layer, or the like deposited by a sputtering or CVD process is used.

Thereafter, on the interlayer dielectric layer **108**, the patterned color filter (i.e., the patterned color layer) **109** is formed. The thickness of the filter **109** is determined such that the surface of the filter **109** is lower than the tops of the protrusions **115** (in other words, the tops of the protrusions **115** protrude from the filter **109**). As a material for the filter **109**, a photosensitive organic resist that is denatured by exposure to light is preferably used. Typically, a negative-

type photosensitive colored resist material, such as PVA (polyvinyl alcohol)-based resins, photosensitive acrylic resins, and photosensitive epoxy resin, is used for this purpose. Actually, this photosensitive organic resist material for red (R) color is coated to form a layer with a desired thickness on the interlayer dielectric layer **108** and then, it is exposed to light with a mask having a desired pattern and developed. These processes are repeated for green (G) and blue (B) colors. Thereafter, these patterned layers are subjected to the main sintering process. Thus, the patterned color filter **109** is formed, as shown in FIG. **8A**. The condition of the said main sintering process is optionally determined. However, it is preferred that the sintering process is carried out at 200 to 230° C. for approximately one hour with a hot plate or the like.

On the color filter **109** thus formed, the patterned light-shielding layer **110** is formed in such a way as to overlap with the respective TFTs **120**, as shown in FIG. **8B**. The layer **110** may be formed by depositing a layer of metal (e.g., Cr) on the filter **109** by sputtering or the like, and patterning the same through photolithography and etching processes. Alternately, the layer **110** may be formed by coating a photosensitive black resist material to form a layer, exposing and developing the layer thus formed with a mask having a desired pattern, and sintering the same.

Following this, the transparent organic interlayer dielectric layer **111** is formed on the color filter **109** to cover the light-shielding layer **110**. The layer **111** is made of an organic material with high chemical resistance. Since the layer **111** is provided to prevent the color filter **109** (which is made of the photosensitive colored resist materials) from being denatured or degraded during the subsequent process steps, the layer **111** needs to be formed to cover the whole filter **109**. The thickness of the layer **111** is typically 2 to 3 μm . In the first embodiment, the thickness of the layer **111** is determined such that the surface of the layer **111** is in the same level as the inorganic interlayer dielectric layer **108** on the respective tops of the protrusions **115**. Therefore, no contact hole is formed to penetrate the layer **111**. The contact holes **105** of the inorganic interlayer dielectric layer **108** and the parts of the source electrodes **107** are exposed from the layer **111** on the corresponding tops of the protrusions **115**.

In the first embodiment, the interlayer dielectric layer **111** is made of a photosensitive resist material having a high chemical resistance. After this resist material is coated on the filter **109** to form a resist layer with a specific thickness, the resist layer is exposed to light with a mask having a desired pattern and developed, thereby forming the layer **111**, as shown in FIG. **8B**. If the resist layer includes some colored regions, preferably, it is subject to a bleaching process by exposing its entirety to light after the development process to thereby decolorize them and thereafter, it is subjected to a main sintering process.

Subsequently, the contact holes **105** are formed to penetrate the interlayer dielectric layer **108** partially exposed from the outermost surface **121** over the corresponding tops of the protrusions **115**. This process is carried out by photolithography and etching processes. The state at this stage is shown in FIG. **8B**.

On the outermost surface **121** (i.e., on the surface of the interlayer dielectric layer **111**), a transparent conductive layer (not shown) is formed by a sputtering process or the like. Then, the conductive layer thus formed is patterned by photolithography and etching processes, forming the pixel electrodes **112** on the surface **121**, as shown in FIG. **8C**. Since the contact holes **105** are formed in the interlayer dielectric layer **108**, the pixel electrodes **112** are contacted

with the corresponding source electrodes **107** by way of the corresponding holes **105**. The state at this stage is shown in FIG. **8C**. In this way, the CF-on-TFT array substrate **100** according to the first embodiment having the structure of FIG. **3** is obtained.

In each of the above-described process steps, it is popular that a cleaning process of the plate is carried out before the layer formation process and the resist coating in the photolithography process. For the cleaning process, brushing cleaning, ultrasonic cleaning, chemical cleaning using isopropanol or the like, or pure water cleaning may be used. A drying process after cleaning is usually carried out using an IR (infrared) heater, a hot plate, or the like, at approximately 120 to 180° C. for approximately two to five minutes.

A method of coating the resist material is optionally selectable. For example, spin coating, slit coating, or the like is used. A drying process under reduced pressure, which is conducted immediately after the resist coating process, is to vaporize the solvent contained in the resist material and to relax the thermal distribution of the resist layer in the subsequent preliminary sintering process. The vacuum pressure to be achieved and the drying period therefor are optionally determined according to the amount of the resist material coated and the percentage of the solvent contained therein. The preliminary sintering process is a process of removing the solvent remaining in the resist layer through vaporization after the drying process under reduced pressure. The preliminary sintering process is usually carried out using a hot plate, an oven, or the like, at approximately 70 to 100° C. for approximately two to four minutes.

After the preliminary sintering process is completed, the plate on which the resist layer has been formed is selectively exposed to light in the exposure process. The method of exposure is optionally selectable. Any method of exposure may be used if it denatures the resist layer. For example, a projection method with a mask or a direct writing method using laser may be preferably used. As the exposing light, any light may be used if it has a wavelength within the sensitivity range of the resist layer. For example, ultraviolet rays, the g, h, or i line of a mercury lamp, light of a xenon lamp, light of an excimer laser, X rays, an electron beam, γ rays, or an ion beam may be used.

The development process after the exposure process is conducted by a method corresponding to the resist material used. As the development fluid, an organic alkali solution or an inorganic alkali solution is usually used.

The etching process may be carried out by any method. Usually, a dry etching method using gas reaction or plasma or a wet etching method using an acid solution is used.

In the formation process of the organic layer, an organic layer is patterned to have a desired shape by the development process and thereafter, a main sintering process is carried out for the organic layer, thereby completing the formation of the patterned organic layer as desired. The main sintering process for the organic layer is conducted with a hot plate, an oven, or the like, at a constant temperature of approximately 0.200 to 230° C. for approximately one hour. Following this, a heating process is conducted to prevent problems such as the generation of volatile materials contained.

As explained above in detail, with the above-described fabrication method, the CF-on-TFT array substrate **100** having the structure of FIG. **3** is easily obtained.

FIG. **4** schematically shows the structure of a LCD device according to the first embodiment. This LCD device comprises the TFT array substrate **100** shown in FIG. **3**, an opposite substrate **200** coupled with the substrate **100** at a

specific gap, and a liquid-crystal layer **400** including a liquid crystal (not shown) confined in the gap. On the substrate **200**, an opposite electrode or electrodes (not shown) is/are formed.

The structure of the opposite substrate **200** and the method of fabricating the same, and the overall structure of the LCD device and the method of assembling the same are well known to the ordinary skill in the art. Therefore, the explanation about them is omitted here for simplicity.

With the LCD device according to the first embodiment of FIG. 4, the TFT array substrate **100** of FIG. 3 is used and thus, the same advantages as those in the substrate **100** are obtainable.

Second Embodiment

Next, a substrate **100A** for a LCD device according to a second embodiment of the invention is explained. While the invention is applied to a CF-on-TFT substrate in the first embodiment, it is applied to an ordinary TFT substrate on which no color filter is provided in the second embodiment.

The structure of the substrate **100A** of the second embodiment is shown in FIG. 9B. As seen from FIG. 9B, the substrate **100A** has the same structure as the substrate **100** of the first embodiment except that the color filter **109** and the light-shielding layer **110** are not formed. Therefore, the explanation about the structure is omitted here for the sake of simplification by attaching the same reference symbols as those used in the first embodiment to the corresponding elements on FIG. 9B.

With the substrate **100A** of the second embodiment, the transparent organic interlayer dielectric layer **111** is formed directly on the inorganic interlayer dielectric layer **108**. The thickness of the layer **111** is determined in such a way that the surface of the layer **111** (i.e., the outermost surface **121**) is in the same level as the layer **108** on the respective tops of the protrusions **115**. Here, the thickness of the layer **111** is set at approximately 1 to 2 μm . The height of the protrusions **115** is set to be approximately equal to the thickness of the layer **111**.

Accordingly, similar to the first embodiment, no deep contact hole is necessary in the contact region **303** for interconnecting one of the source electrodes **107** with a corresponding one of the pixel electrodes **112**. As a result, the flatness of the outermost surface **121** of the substrate **100A** is vastly improved in the contact region **303**, thereby making the whole surface **121** approximately flat. Thus, the same advantages as those in the first embodiment are obtainable.

A method of fabricating the substrate **100A** of the second embodiment is the same as the method of fabricating the substrate **100** of the first embodiment, except that the processes of forming the color filter **109** and the light-shielding layer **110** are unnecessary.

Specifically, after the inorganic interlayer dielectric layer **108** is formed in the same way as the first embodiment, the transparent organic interlayer dielectric layer **111** is formed on the layer **108**, as shown in FIG. 9A. Since the thickness of the layer **111** is determined such that the surface of the layer **111** is in the same level as the layer **108** on the respective protrusions **115**, the layer **111** does not have any contact hole. The layer **108** is partially exposed from the layer **111** on the tops of the protrusions **115** at this stage.

Subsequently, the contact holes **105**, which are used for electrically connecting the pixel electrodes **112** to the corresponding source electrodes **107**, are formed to penetrate

the layer **108** exposed from the layer **111** on the respective protrusions **115**. The state at this stage is shown in FIG. 9B.

Finally, on the surface of the interlayer dielectric layer **111** (i.e., on the outermost surface **121**), the pixel electrodes **121** are formed, as shown in FIG. 9B. In this way, the TFT array substrate **100A** of the second embodiment is obtained.

Other Embodiments

It is needless to say that the present invention is not limited to the above-described first and second embodiments. Any modification is applicable to these embodiments. For example, although a TFT is used as the switching element in the above-described embodiments, any other switching element such as a field-effect transistor (MOS-FET) using a single-crystal substrate may be used. As the semiconductor layer for the TFTs, any other semiconductor material such as polysilicon may be used instead of a-Si layer.

Moreover, in the above-described embodiments, the source electrode **107** covers the whole side face and the whole top face of the corresponding protrusion **115**. However, the invention is not limited to this. It is sufficient for the invention that the source electrode **107** contacts the corresponding pixel electrode **112** in the vicinity of the outermost surface **121** (i.e., in the position vertically away from the plate **101**). It is not always necessary for the electrode **107** to cover the whole side face and the whole top face of the corresponding protrusion **115**.

Not to mention, the shape and height of the protrusion **115** are optionally adjustable. The material of the protrusion **115** is optionally selectable if it forms and keeps the shape of the protrusion **115**.

While the preferred forms of the present invention have been described, it is to be understood that modifications will be apparent to those skilled in the art without departing from the spirit of the invention. The scope of the present invention, therefore, is to be determined solely by the following claims.

What is claimed is:

1. A substrate for a LCD device comprising:

- a transparent plate;
- switching elements for respective pixels, formed on the plate;
- protrusions for the respective pixels, formed on the plate in such a way as to protrude to a vicinity of an outermost surface of the substrate;
- each of the protrusions raising an electrode of a corresponding one of the switching elements to the vicinity of the outermost surface in a corresponding one of the pixels;
- a planarization layer formed in such a way as to cover the switching elements, the protrusions, and the electrodes of the elements in all the pixels, a surface of the planarization layer forming the outermost surface, the planarization layer having at least one contact hole formed over each corresponding protrusion, partially exposing the electrodes;
- pixel electrodes for the respective pixels, formed on the outermost surface; and
- each of the pixel electrodes being contacted with a corresponding one of the electrodes of the switching elements in the vicinity of the outermost surface.

2. The substrate according to claim 1, wherein the switching elements are TFTs, and the electrodes of the switching elements are source electrodes or drain electrodes of the TFTs.

3. The substrate according to claim 1, wherein each of the electrodes of the switching elements is extended along top and side faces of a corresponding one of the protrusions.

4. The substrate according to claim 1, wherein each of the electrodes of the switching elements is extended along top and side faces of a corresponding one of the protrusions, and is contacted with a corresponding one of the pixel electrodes at a top of a corresponding one of the protrusions.

5. The substrate according to claim 1, wherein the planarization layer includes a transparent organic interlayer dielectric sublayer.

6. The substrate according to claim 1, further comprising a color filter; wherein a distance between a top of each of the protrusions and the outermost surface is shorter than a distance between a top of the color filter and the outermost surface.

7. The substrate according to claim 1, further comprising a color filter; wherein a boundary of the filter on a side of each of the protrusions is superposed on a boundary of the planarization layer on a side of each of the protrusions.

8. A method of fabricating a substrate for a LCD device, comprising the steps of:

forming protrusions for respective pixels on a transparent plate in such a way as to protrude to a vicinity of an outermost surface of the substrate;

forming switching elements for the respective pixels in such a way that electrodes of the elements are raised by the corresponding protrusions to the vicinity of the outermost surface;

forming a planarization layer in such a way as to cover the switching elements, the protrusions, and the electrodes of the elements in all the pixels, a surface of the planarization layer forming the outermost surface;

forming at least one contact hole on the planarization layer and over each corresponding protrusion, partially exposing the electrodes; and

forming pixel electrodes for the respective pixels on the outermost surface;

wherein each of the pixel electrodes is contacted with a corresponding one of the electrodes of the switching elements in the vicinity of the outermost surface.

9. The method according to claim 8, wherein the switching elements are TFTs, and the electrodes of the switching elements are source electrodes or drain electrodes of the TFTs.

10. The method according to claim 8, wherein each of the electrodes of the switching elements is formed to extend along top and side faces of a corresponding one of the protrusions.

11. The method according to claim 8, wherein each of the electrodes of the switching elements is formed to extend along top and side faces of a corresponding one of the protrusions and to contact a corresponding one of the pixel electrodes at a top of a corresponding one of the protrusions.

12. The method according to claim 8, wherein the planarization layer includes a transparent organic interlayer dielectric sublayer.

13. The method according to claim 8, further comprising a step of forming a color filter; wherein a distance between a top of each of the protrusions and the outermost surface is shorter than a distance between a top of the color filter and the outermost surface.

14. The method according to claim 8, further comprising a step of forming a color filter; wherein a boundary of the filter on a side of each of the protrusions is superposed on a boundary of the planarization layer on a side of each of the protrusions.

15. A LCD device comprising:

a first substrate;

a second substrate coupled with the first substrate to be opposite to each other at a gap; and

a liquid-crystal layer formed in the gap;

wherein the first substrate comprises:

a transparent plate;

switching elements for respective pixels, formed on the plate;

protrusions for the respective pixels, formed on the plate in such a way as to protrude to a vicinity of an outermost surface of the substrate;

each of the protrusions raising an electrode of a corresponding one of the switching elements to the vicinity of the outermost surface in a corresponding one of the pixels;

a planarization layer formed in such a way as to cover the switching elements, the protrusions, and the electrodes of the elements in all the pixels, a surface of the planarization layer forming the outermost surface, the planarization layer having at least one contact holes formed over each corresponding protrusion, partially exposing the electrodes;

pixel electrodes for the respective pixels, formed on the outermost surface; and

each of the pixel electrodes being contacted with a corresponding one of the electrodes of the switching elements in the vicinity of the outermost surface.

16. The substrate according to claim 1, further comprising an interlayer dielectric layer covering the switching elements and the protrusions, the interlayer dielectric layer being located between the switching elements and protrusions, and the planarization layer, the surface of the planarization layer is in a same level as a surface of the interlayer dielectric layer on the protrusions.

17. The substrate according to claim 16, wherein the at least one contact hole is formed to penetrate is formed to penetrate the interlayer dielectric layer over each corresponding protrusion.

18. The method according to claim 8, further comprising the step of forming an interlayer dielectric layer covering the switching elements and the protrusions, the interlayer dielectric layer being located between the switching elements and protrusions, and the planarization layer, the surface of the planarization layer is in a same level as a surface of the interlayer dielectric layer on the protrusions.

19. The method according to claim 18, wherein the at least one contact hole is formed to penetrate is formed to penetrate the interlayer dielectric layer over each corresponding protrusion.

* * * * *

专利名称(译)	用于液晶显示装置的基板及其制造方法		
公开(公告)号	US6982769	公开(公告)日	2006-01-03
申请号	US10/638000	申请日	2003-08-08
[标]申请(专利权)人(译)	NEC液晶技术株式会社		
申请(专利权)人(译)	NEC液晶技术有限公司.		
当前申请(专利权)人(译)	GETNER FOUNDATION LLC		
[标]发明人	ISHINO TAKAYUKI		
发明人	ISHINO, TAKAYUKI		
IPC分类号	G02F1/136 G02F1/1333 G02F1/1335 G02F1/1343 G02F1/1362 G02F1/1368 H01L21/336 H01L29/786		
CPC分类号	G02F1/136227 G02F2001/136222		
审查员(译)	NGUYEN, 龚便T.		
助理审查员(译)	王, GEORGE Y.		
优先权	2002232542 2002-08-09 JP		
其他公开文献	US20040046912A1		
外部链接	Espacenet USPTO		

摘要(译)

用于LCD器件的基板改善了接触区域中最外基板表面的平坦度，用于在每个像素中将开关元件（例如，TFT）的电极和像素电极彼此互连。各个像素的开关元件形成在透明板上。用于各个像素的突起形成在板上以突出到基板的最外表面附近。每个突起将相应的开关元件的电极升高到相应像素中的最外表面附近。形成形成最外表面的平坦化层以覆盖所有像素中的元件的开关元件，突起和电极。用于各个像素的像素电极形成在最外表面上。每个像素电极在最外表面附近接触元件的相应电极。

