



US006424396B1

(12) **United States Patent**
Kim et al.

(10) **Patent No.:** **US 6,424,396 B1**
(45) **Date of Patent:** **Jul. 23, 2002**

(54) **VERTICALLY ALIGNED LIQUID CRYSTAL DISPLAY**

6,100,953 A * 8/2000 Kim et al. 349/129

* cited by examiner

(75) Inventors: **Jae-Hoon Kim**, Yongin; **Jang-Kun Song**, Seoul, both of (KR)

(73) Assignee: **Samsung Electronics Co., Ltd.**, Suwon (KR)

Primary Examiner—Kenneth Parker

Assistant Examiner—David Chung

(74) *Attorney, Agent, or Firm*—McGuireWoods LLP

(*) Notice: Subject to any disclaimer, the term of this patent is extended or adjusted under 35 U.S.C. 154(b) by 0 days.

(57) **ABSTRACT**

Disclosed is a liquid crystal display comprising a first substrate made of an insulating material; pixel electrodes formed on the first substrate, the pixel electrodes having a first aperture pattern; a second substrate made of an insulating material and provided opposing the first substrate at a predetermined distance; a common electrode formed on the second substrate, the common electrode having a second aperture pattern; and a liquid crystal layer made of liquid crystal material that is injected between the first and second substrates, wherein either or both of the pixel electrodes and the common electrode include stepped portions that protrude a predetermined distance away from the substrates, between apertures of the first and/or second aperture patterns.

(21) Appl. No.: **09/901,128**

(22) Filed: **Jul. 10, 2001**

(30) **Foreign Application Priority Data**

Jul. 27, 2000 (KR) 2000-43507

(51) **Int. Cl.**⁷ **G02F 1/1337**

(52) **U.S. Cl.** **349/130; 349/129; 349/143**

(58) **Field of Search** **349/129, 143, 349/130**

(56) **References Cited**

U.S. PATENT DOCUMENTS

6,081,315 A * 6/2000 Matsuyama et al. 349/143

7 Claims, 2 Drawing Sheets

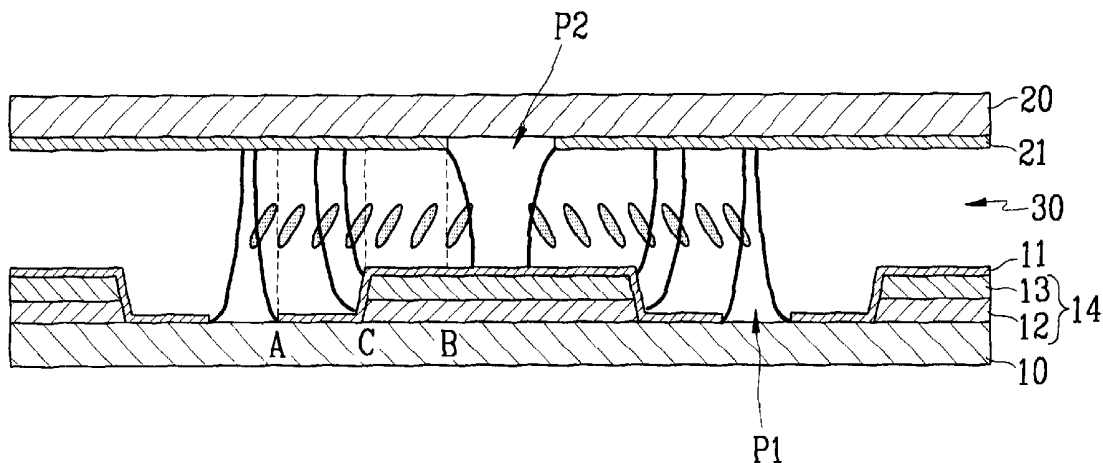

FIG. 1

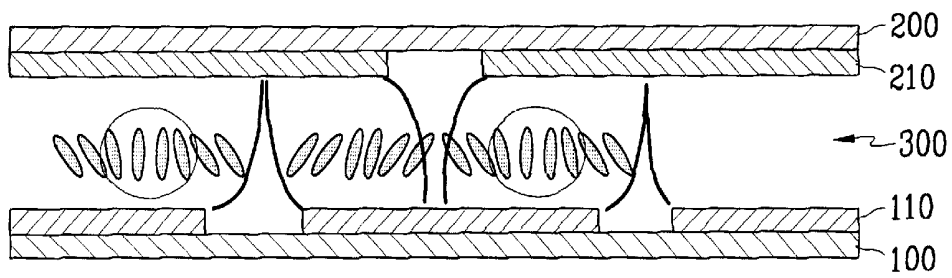

FIG. 2

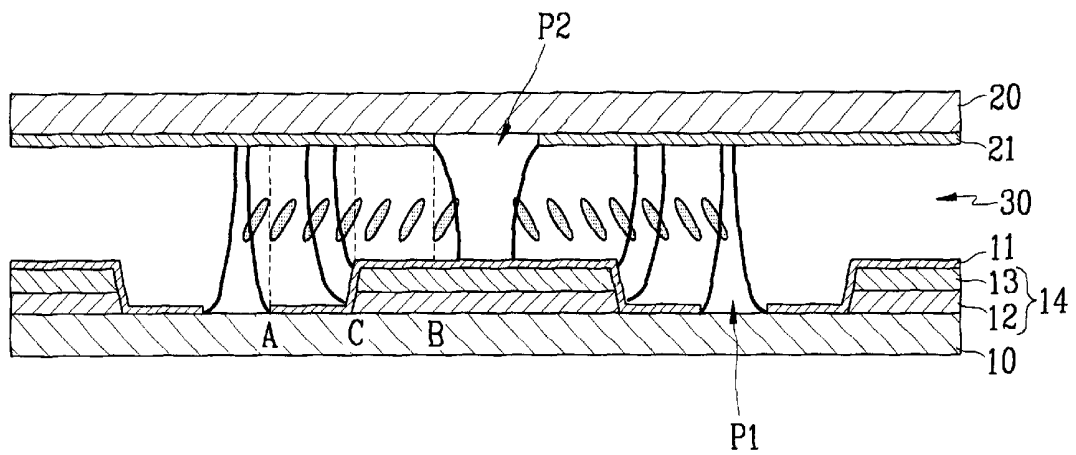

FIG. 3

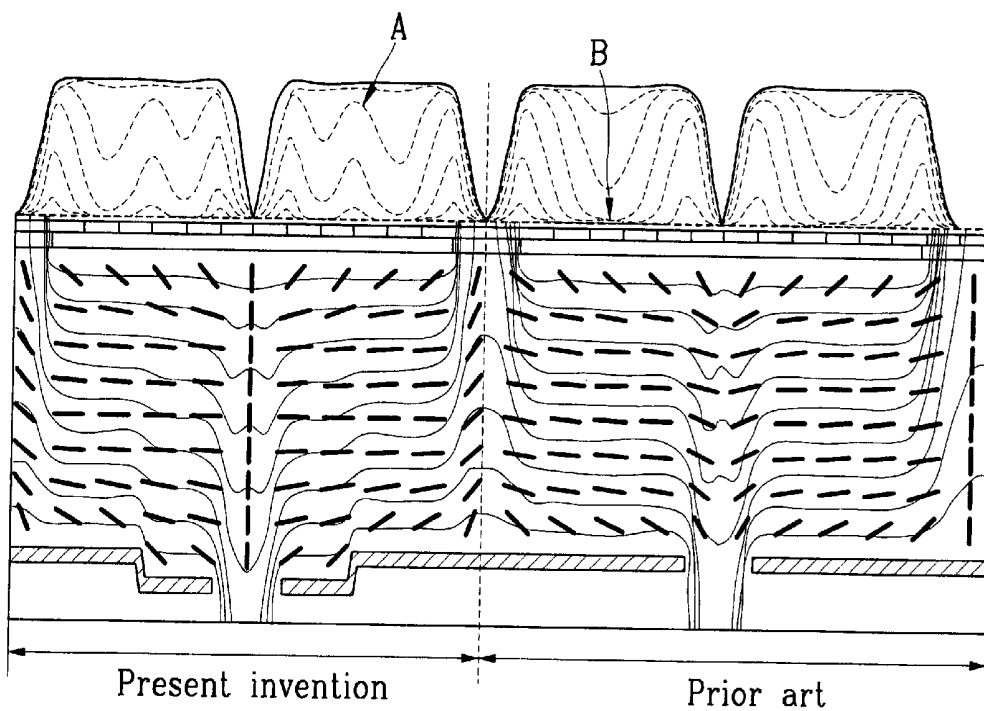
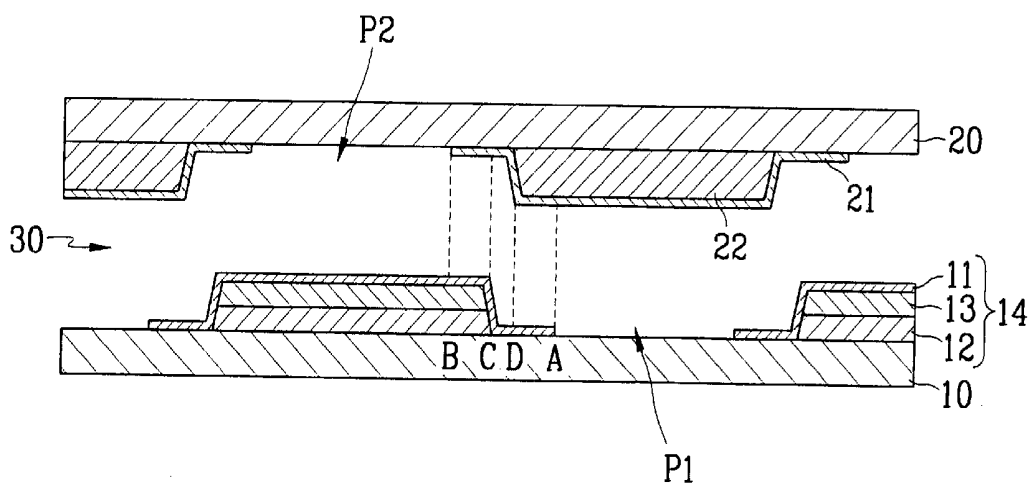

FIG. 4



VERTICALLY ALIGNED LIQUID CRYSTAL DISPLAY

BACKGROUND OF THE INVENTION

(a) Field of the Invention

The present invention relates to a vertically aligned liquid crystal display, and more particularly, to a vertically aligned liquid crystal display having an aperture pattern formed in electrodes to obtain a wide viewing angle.

(b) Description of the Related Art

A liquid crystal display (LCD) is structured having liquid crystal injected between an upper substrate having a common electrode and a color filter, and a lower substrate having thin film transistors and pixel electrodes. A voltage of a different potential is applied to the pixel electrodes and common electrode to form an electric field, thereby varying the alignment of liquid crystal molecules of the liquid crystal material. In this way, the transmittance of incident light is controlled to display images.

In a vertically aligned (VA) LCD, long axes of the liquid crystal molecules align themselves vertically to the substrates in a state where no electric field is formed between the substrates. The VALCD has a high contrast ratio and a wide viewing angle such that this LCD configuration is the most commonly used type of liquid crystal display.

In one method to obtain a wide viewing angle in the VA LCD, aperture patterns are formed in the electrodes. With this configuration, a fringe field is used to uniformly scatter a slanting direction of the liquid crystal molecules into four directions to achieve a wide viewing angle. A conventional VA LCD, having aperture patterns formed in the electrodes to obtain a wide viewing angle, will now be described with reference to FIG. 1.

FIG. 1 shows a partial sectional view of a conventional VA LCD having aperture patterns formed in electrodes.

A pixel electrode **110** is formed on an insulating lower substrate **100**, and a common electrode **210** is formed on an insulating upper substrate **200**. Aperture patterns are formed in the pixel electrode **110** and the common electrode **210**. Apertures of the aperture pattern of the pixel electrode **110** are provided alternately with apertures of the aperture pattern of the common electrode **210**. Further, liquid crystal material is injected between the substrates **100** and **200** to form a liquid crystal layer **300**.

As shown in the drawing, a fringe field generated by the aperture patterns uniformly controls a slanting direction of liquid crystal molecules of the liquid crystal layer **300**. A wide viewing angle is realized as a result. However, at center portions between apertures of the upper substrate **200** and the lower substrate **100**, weak fringe field forms an area by the vertical electric field with respect to the substrates where the liquid crystal molecules do not quickly change alignments by the electrical field. Also, the liquid crystal molecules in these areas begin to slant only after liquid crystal molecules in the vicinity of the aperture patterns are slanted. This slows down the response speed of the LCD.

SUMMARY OF THE INVENTION

The present invention has been made in an effort to solve the above problems.

It is an object of the present invention to provide a vertically aligned liquid crystal display in which a lower and an upper aperture pattern are formed in electrodes of at least one substrate to form a stepped pattern at the center of the aperture pattern. Accordingly, a response speed is improved.

To achieve the above object, the present invention provides a liquid crystal display comprising a first substrate made of an insulating material; pixel electrodes formed on the first substrate, the pixel electrodes having a first aperture pattern; a second substrate made of an insulating material and provided opposing the first substrate at a predetermined distance; a common electrode formed on the second substrate, the common electrode having a second aperture pattern; and a liquid crystal layer made of liquid crystal material injected between the first substrate and the second substrate, wherein either or both of the pixel electrodes and the common electrode include stepped portions, which protrude a predetermined distance away from the substrates, between apertures of the first and/or second aperture patterns.

According to a feature of the present invention, the pixel electrodes include the stepped portions.

According to another feature of the present invention, the stepped portions are formed by providing the pixel electrodes over a gate insulation layer and a protection layer.

According to yet another feature of the present invention, the common electrode includes the stepped portions.

According to still yet another feature of the present invention, the pixel electrodes include first stepped portions and the common electrode includes second stepped portions.

According to still yet another feature of the present invention, the first stepped portions and the second stepped portions are provided in a sequence of the first aperture pattern, the second stepped portions, the first stepped portions, and the second aperture pattern.

According to still yet another feature of the present invention, the liquid crystal display further comprises thin film transistors formed on the first substrate, the thin film transistors switching image signals transmitted to the pixel electrodes.

BRIEF DESCRIPTION OF THE DRAWINGS

The accompanying drawings, which are incorporated in and constitute a part of the specification, illustrate an embodiment of the invention, and, together with the description, serve to explain the principles of the invention:

FIG. 1 is a partial sectional view of a conventional vertically aligned liquid crystal display;

FIG. 2 is a partial sectional view of a vertically aligned liquid crystal display according to a first preferred embodiment of the present invention;

FIG. 3 is a combination sectional view and transmissivity graph comparing the vertically aligned liquid crystal display of the first preferred embodiment of the present invention with a conventional vertically aligned liquid crystal display; and

FIG. 4 is a partial sectional view of a vertically aligned liquid crystal display according to a second preferred embodiment of the present invention.

DETAILED DESCRIPTION OF THE PREFERRED EMBODIMENTS

Preferred embodiments of the present invention will now be described in detail with reference to the accompanying drawings.

FIG. 2 shows a partial sectional view of a vertically aligned liquid crystal display according to a first preferred embodiment of the present invention.

A pixel electrode **11** is formed on a lower substrate **10**, the lower substrate **10** being made of an insulating material such

as glass, and a common electrode 21 is formed on an upper substrate 20, which is also made of an insulating material. A first aperture pattern P1 and a second aperture pattern P2 are formed respectively in the pixel electrode 11 and the common electrode 21. Apertures of the first aperture pattern P1 are provided alternately with apertures of the second aperture pattern P2. Plateaus 14 are formed on the lower substrate 10. The pixel electrode 11 is formed over the plateaus 14 such that stepped portions are formed. The plateaus 14 are formed by a gate insulating layer 12 and a protection layer 13.

The stepped portions start at roughly a center between an edge A of the apertures of the first aperture pattern P1 and an edge B of the apertures of the second aperture pattern P2, that is at areas C. Since a fringe field is also formed by the stepped portions, the liquid crystal molecules positioned over areas C quickly respond to a generated electric field.

In a liquid crystal display, many more elements than those described above are provided on the lower and upper substrates 10 and 20. For example, additionally provided on the lower substrate 10 are gate wiring, data wiring, and thin film transistors, and additionally provided on the upper substrate 20 are a color filter and a black matrix. The gate wiring transmits scanning signals, the data wiring transmits image signals, and the thin film transistors act as a switching element to either transmit or cut off the image signals to the pixel electrode 11 according to the scanning signals. These elements do not appear in the drawing to simplify the explanation of the first embodiment.

FIG. 3 shows a combined sectional view and transmissivity graph comparing the vertically aligned liquid crystal display of the first preferred embodiment of the present invention with a conventional vertically aligned liquid crystal display.

In FIG. 3, it is to be assumed that a drive voltage be applied after a threshold voltage of 1.7V is applied for 150 msec. Shapes of equipotential lines and alignment of liquid crystal molecules are shown in the lower part of FIG. 3, while the curved lines of the upper part of FIG. 3 are transmissivity curves, in which the changes are with respect to time.

As shown by area B of the conventional LCD, in which no stepped portion is provided, light transmissivity slowly decreases with time at areas between the apertures of the aperture patterns. On the other hand, in the present invention having stepped portions, the liquid crystal molecules at areas between the apertures of the aperture patterns are aligned simultaneously with the liquid crystal molecules at edges of the apertures as a result of the transformed electric field due to the stepped portions. Accordingly, with reference to area A, a light transmissivity is nearly identical throughout the liquid crystal display of the present invention, thereby enhancing response speed.

Table 1 below shows a comparison between response speeds of the conventional LCD and the LCD of the present invention at different gray levels.

TABLE 1

Starting voltage (V)	Applied voltage (V)	Prior art (ms)	Present invention (ms)	Difference in time (ms)
1.7	2.5	147	123	24
	3.0	80	64	16
	3.5	47	38	9
	4.0	32	25	7

TABLE 1-continued

Starting voltage (V)	Applied voltage (V)	Prior art (ms)	Present invention (ms)	Difference in time (ms)
2.0	5.0	16	13	3
	2.5	120	100	20
	3.0	67	58	10
Average		72.7	60.14	12.56

As shown in Table 1, the present invention has a response speed at all gray levels that is faster than the conventional LCD. Of particular interest is the improvement in response speed of between 20 and 25 ms at low gray levels.

FIG. 4 shows a partial sectional view of a vertically aligned liquid crystal display according to a second preferred embodiment of the present invention.

A pixel electrode 11 is formed on a lower substrate 10, the lower substrate 10 being made of an insulating material such as glass, and a common electrode 21 is formed on an upper substrate 20, which is also made of an insulating material. A first aperture pattern P1 and a second aperture pattern P2 are formed respectively in the pixel electrode 11 and the common electrode 21. Apertures of the first aperture pattern P1 are provided alternately with apertures of the second aperture pattern P2. Plateaus 14 are formed between the pixel electrode 11 and the lower substrate 10, and plateaus 22 are formed between the common electrode 21 and the upper substrate 20. As a result, stepped portions are formed on the lower and upper substrates 10 and 20. The plateaus 14 of the lower substrate 10 are formed of a gate insulating layer 12 and a protection layer 13.

The stepped portions of the lower substrate 10 and the upper substrates 20 start at a center area between an edge A of the apertures of the first aperture pattern P1 and an edge B of the apertures of the second aperture pattern P2. That is, areas C, at which point the stepped portions of the lower substrate 10 begin to form, are misaligned with areas D, at which point the stepped portions of the upper substrate 20 begin to form.

By forming the stepped portions also on the upper substrate 20, the further increased effects of varying the electric field improve the response speed.

In the LCDs of the present invention described above, stepped portions are formed only on the lower substrate and on both the upper and lower substrates. However, it is also possible to form protruding areas only on the upper substrate. A detailed description of such a configuration will be omitted, as such modifications will be well known to one of ordinary skill in the art.

In the present invention, the response speed of the liquid crystal display is improved by forming stepped portions between apertures of the lower substrate and the upper substrate. That is, by the transformed electric field resulting from the stepped portions, the slanting direction of the liquid crystal molecules is better controlled in areas between the apertures to enhance the overall response speed.

Although preferred embodiments of the present invention have been described in detail hereinabove, it should be clearly understood that many variations and/or modifications of the basic inventive concepts herein taught which may appear to those skilled in the present art will still fall within the spirit and scope of the present invention, as defined in the appended claims.

What is claimed is:

1. A liquid crystal display, comprising:

5

a first substrate made of an insulating material;
pixel electrodes formed on said first substrate, said pixel
electrodes having a first aperture pattern;

a second substrate made of an insulating material and
facing said first substrate at a predetermined distance;

a common electrode formed on said second substrate, said
common electrode having a second aperture pattern;
and

a liquid crystal layer made of liquid crystal material
injected between said first substrate and said second
substrate,

wherein at least one of said pixel electrodes and said
common electrode include a stepped portion, which
protrudes a predetermined distance away from the
substrates, between the first aperture pattern and the
second aperture pattern.

2. The liquid crystal display of claim 1, wherein said pixel
electrodes include the stepped portion.

6

3. The liquid crystal display of claim 2, wherein the
stepped portion is formed by providing the pixel electrodes
over a gate insulation layer and a protection layer.

4. The liquid crystal display of claim 1, wherein said
common electrode includes the stepped portion.

5. The liquid crystal display of claim 1, wherein said pixel
electrodes include a first stepped portion and said common
electrode includes a second stepped portion.

6. The liquid crystal display of claim 5, wherein the first
stepped portion and the second stepped portion are provided
in a sequence of the first aperture pattern, the second stepped
portion, the first stepped portion, and the second aperture
pattern.

7. The liquid crystal display of claim 1, further comprising
a thin film transistor formed on said first substrate, the thin
film transistor switching image signals transmitted to the
pixel electrode.

* * * * *

专利名称(译)	垂直对齐的液晶显示器		
公开(公告)号	US6424396	公开(公告)日	2002-07-23
申请号	US09/901128	申请日	2001-07-10
[标]申请(专利权)人(译)	KIM JAE HOON SONG JANG KUN		
申请(专利权)人(译)	KIM JAE勋 SONG JANG-KUN		
当前申请(专利权)人(译)	SAMSUNG ELECTRONICS CO. , LTD.		
[标]发明人	KIM JAE HOON SONG JANG KUN		
发明人	KIM, JAE-HOON SONG, JANG-KUN		
IPC分类号	G02F1/13 G02F1/1333 G02F1/1343 G02F1/139 G02F1/1337 G02F1/136 G02F1/1368 G09F9/30 G02F1/133		
CPC分类号	G02F1/133371 G02F1/133707 G02F1/134336 G02F1/1393 G02F2201/121		
审查员(译)	PARKER , KENNETH		
助理审查员(译)	CHUNG , DAVID		
优先权	1020000043507 2000-07-27 KR		
其他公开文献	US20020030781A1		
外部链接	Espacenet USPTO		

摘要(译)

公开了一种液晶显示器，包括由绝缘材料制成的第一基板；像素电极形成在第一基板上，像素电极具有第一孔图案；第二基板，由绝缘材料制成，并以预定距离与第一基板相对设置；公共电极形成在第二基板上，公共电极具有第二孔图案；液晶材料制成的液晶层注入第一和第二基板之间，其中像素电极和公共电极中的任一个或两个包括在第一和第二基板的孔之间突出预定距离的台阶部分和/或第二孔径图案。

