



US 20040125313A1

(19) **United States**

(12) **Patent Application Publication**  
**Lim**

(10) **Pub. No.: US 2004/0125313 A1**

(43) **Pub. Date: Jul. 1, 2004**

(54) **LIQUID CRYSTAL DISPLAY DEVICE AND METHOD OF FABRICATING THE SAME**

(52) **U.S. Cl. .... 349/152**

(75) **Inventor: Byoung Ho Lim, Gyeongsangbuk-do (KR)**

(57) **ABSTRACT**

Correspondence Address:  
**MORGAN LEWIS & BOCKIUS LLP**  
**1111 PENNSYLVANIA AVENUE NW**  
**WASHINGTON, DC 20004 (US)**

A method of fabricating a liquid crystal display device includes forming a gate electrode, a gate bus line, and a gate pad on a substrate using a first mask process, forming a gate insulating layer and an active layer on an entire surface of the substrate, forming a first organic material film on an entire surface of the substrate, removing a portion of the first organic material film to expose a first portion of the gate pad, depositing a transparent film on an entire surface of the substrate, patterning the transparent film using a second half-tone mask to form a data bus line, a source electrode, a drain electrode, a pixel electrode, a channel layer, and an ohmic contact layer, exposing portions of the data pad and data bus line using a third mask, forming a second organic material film on an entire surface of the substrate, depositing a low resistance material on the data bus line, coating a passivation film on the substrate, removing the second organic material film using a lift-off process to expose a second portion of the gate pad and a first portions of the data pad.

(73) **Assignee: LG.PHILIPS LCD CO., LTD.**

(21) **Appl. No.: 10/725,055**

(22) **Filed: Dec. 2, 2003**

(30) **Foreign Application Priority Data**

Dec. 30, 2002 (KR) ..... 86560/2002

**Publication Classification**

(51) **Int. Cl.<sup>7</sup> ..... G02F 1/1345**

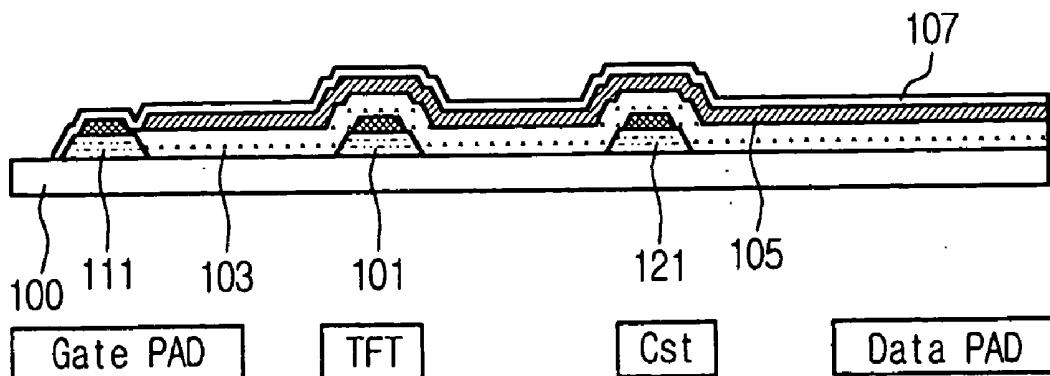

Fig.1  
Related Art

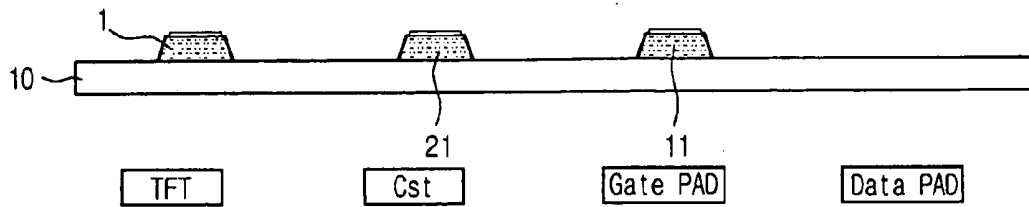

Fig.2  
Related Art

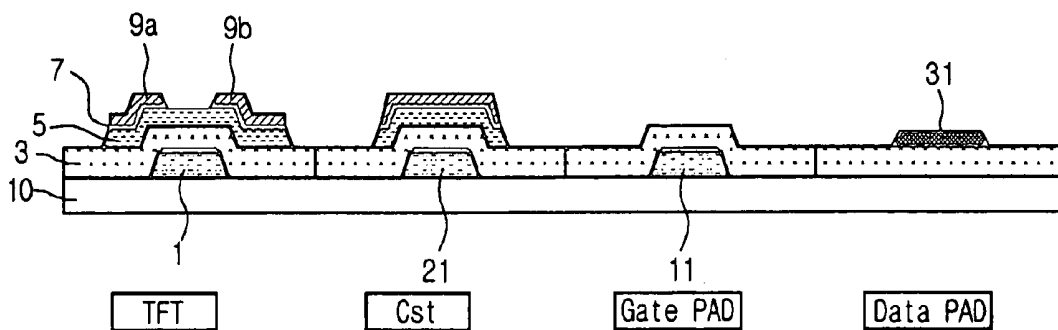

Fig.3  
Related Art

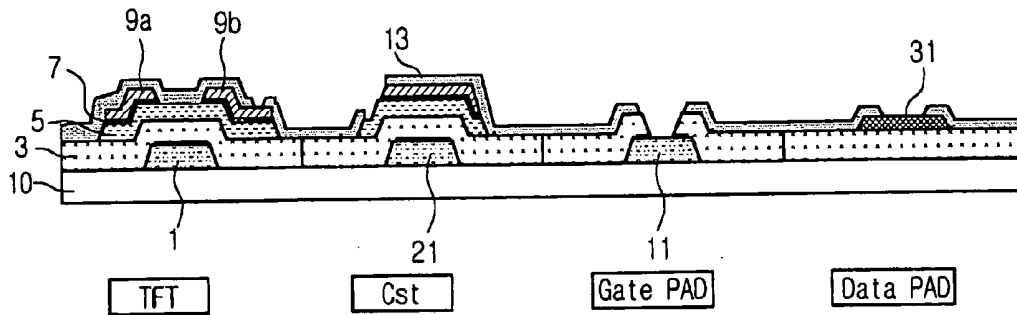

Fig.4  
Related Art

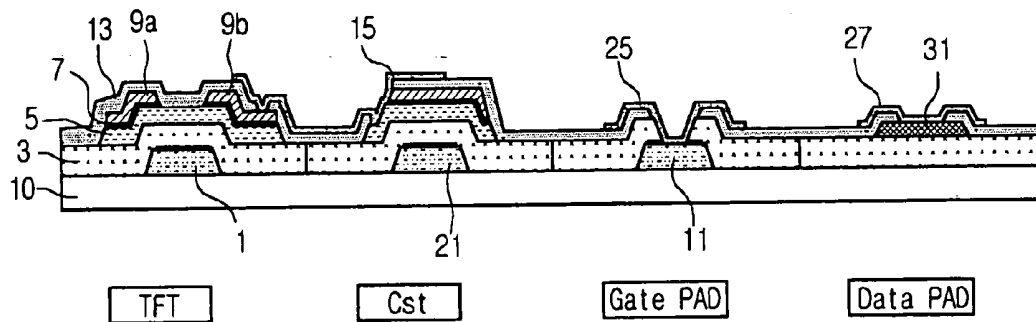

Fig.5

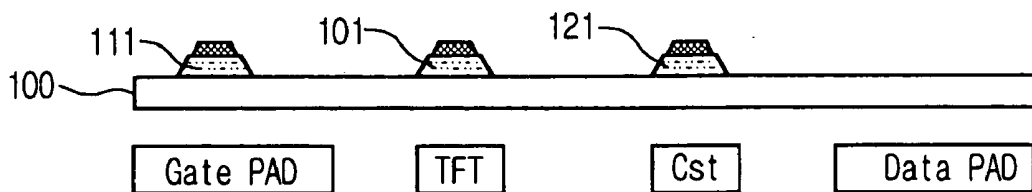

Fig.6A

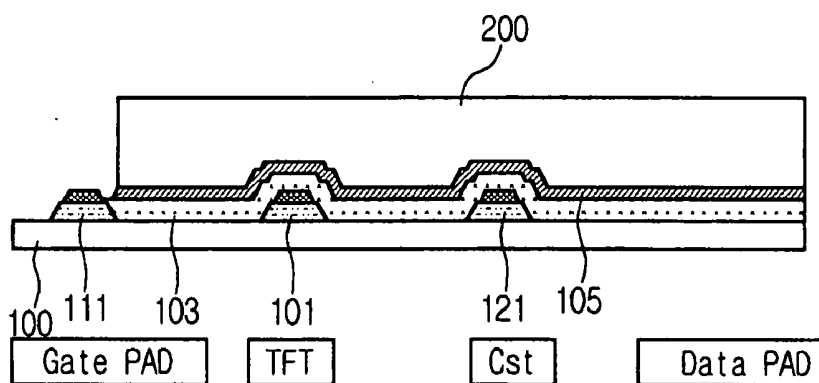

Fig.6B

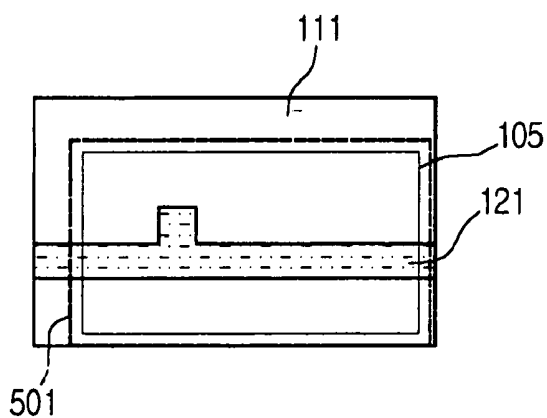

Fig.7

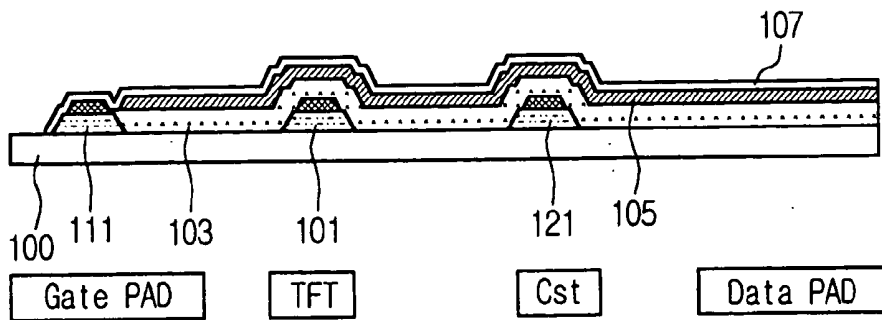

Fig.8

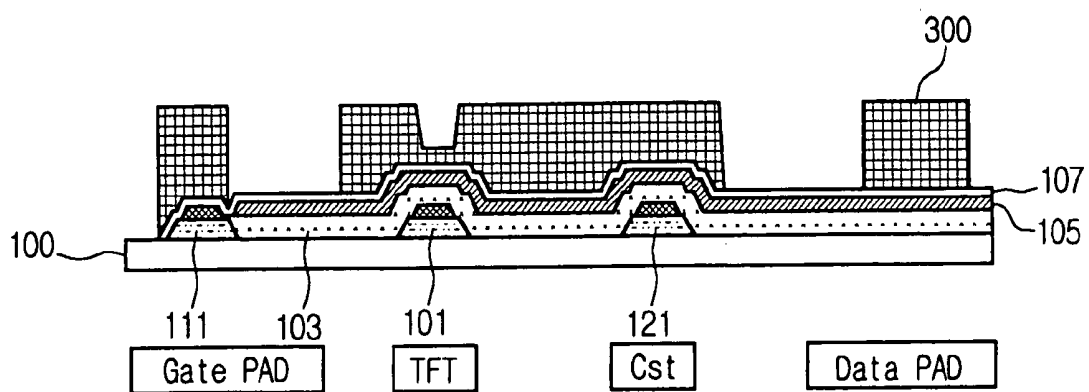

Fig.9A

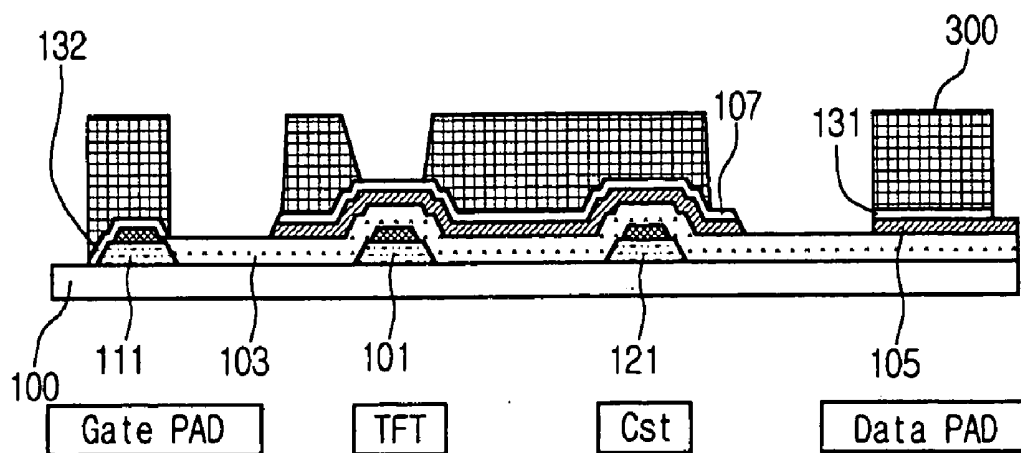

Fig.9B

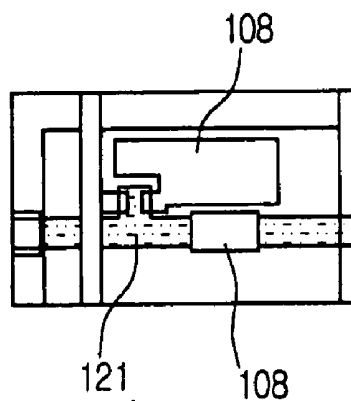

Fig. 10A

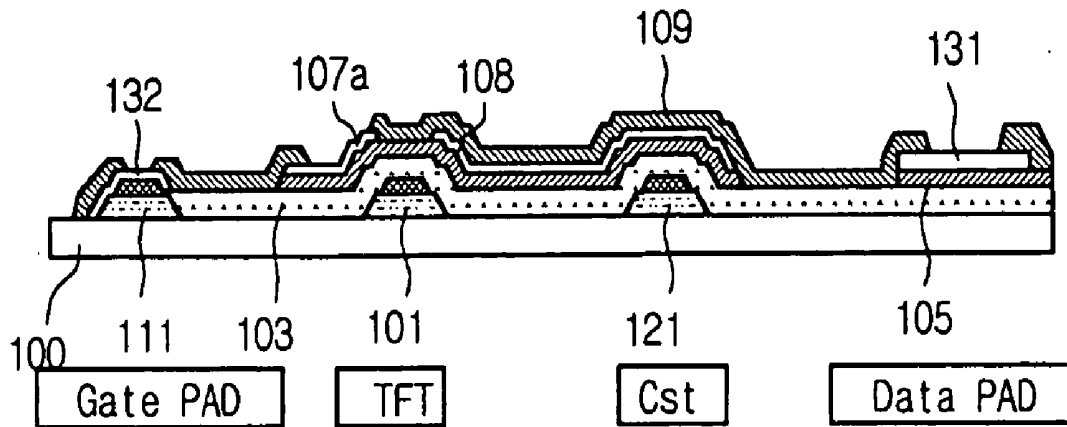

Fig. 10B

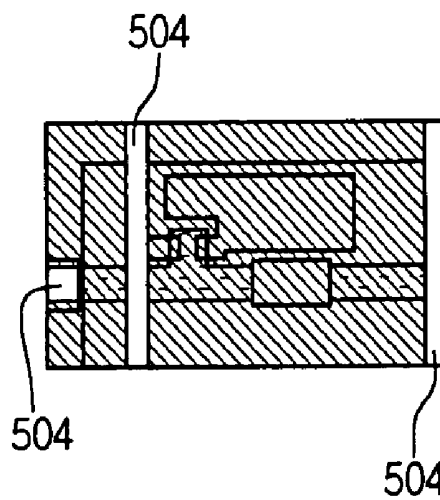

Fig.11

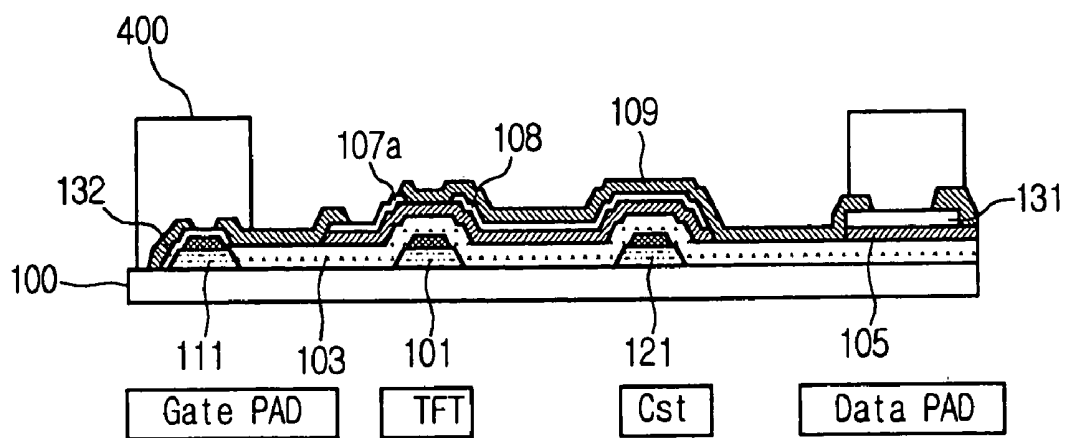

Fig.12A

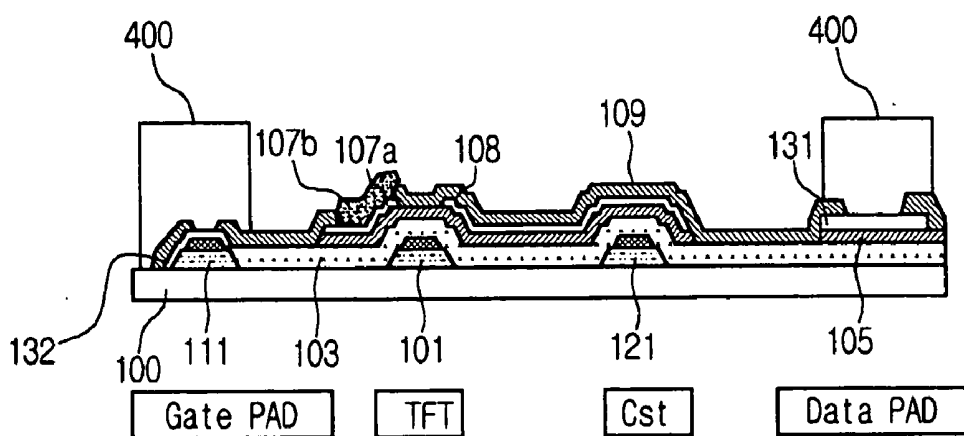

Fig.12B

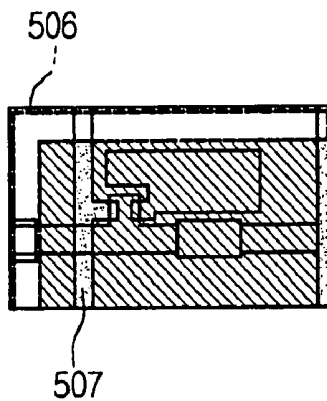

Fig. 13A

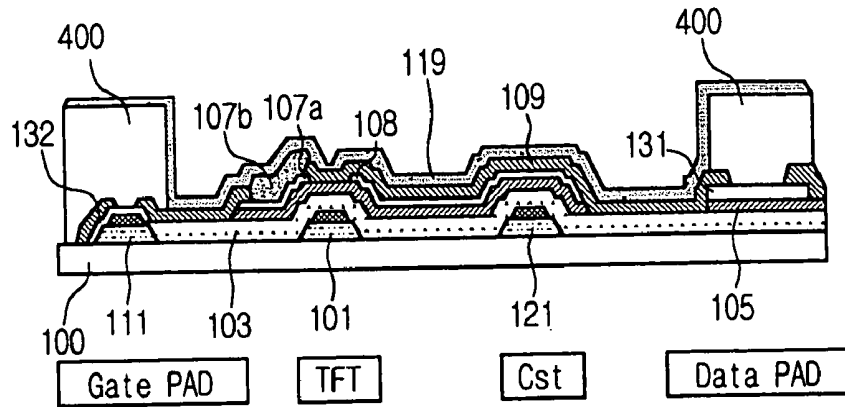

Fig. 13B

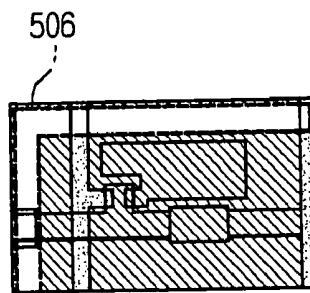
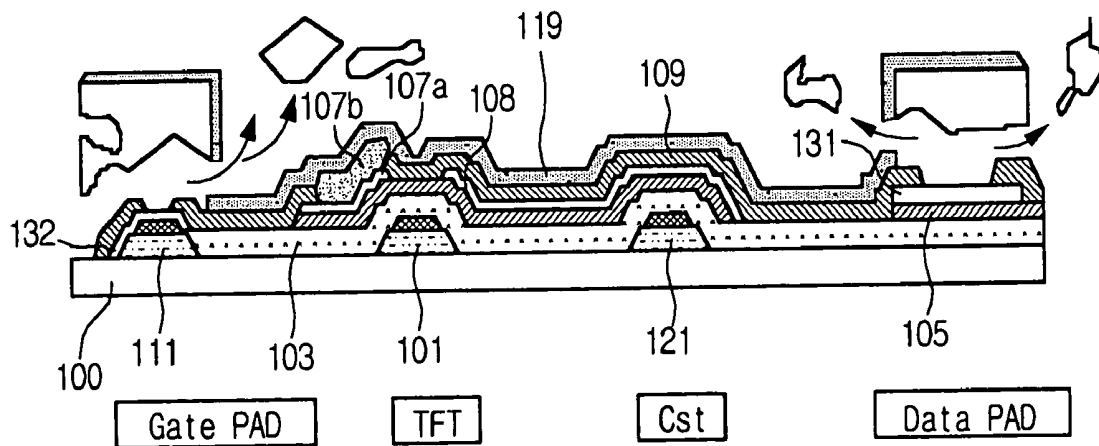

Fig. 14





## LIQUID CRYSTAL DISPLAY DEVICE AND METHOD OF FABRICATING THE SAME

[0001] The present invention claims the benefit of Korean Patent Application No. 86560/2002 filed in Korea on Dec. 30, 2002, which is hereby incorporated by reference.

### BACKGROUND OF THE INVENTION

[0002] 1. Field of the Invention

[0003] The present invention relates to a display device and a method of fabricating a display device, and more particularly, to a liquid crystal display device and a method of fabricating a liquid crystal display device.

[0004] 2. Description of the Related Art

[0005] In general, cathode ray tube (CRT) devices have been commonly used to display images. However, due to their size and weight limitations, the CRT devices are increasingly being replaced with liquid crystal display (LCD) devices that are small sized and lightweight, and have low profiles and low power consumption.

[0006] The LCD devices include an array substrate upon which thin film transistors (TFTs) are arranged, a color filter substrate upon which red, green, and blue color filter layers are formed and which is attached to the array substrate, and liquid crystal material interposed between the array and color filter substrates. The array and color filter substrates are formed by patterning and etching metal and insulating layers using photolithographic processes including several masking steps.

[0007] Fabrication of the array substrate includes a first mask step, wherein a metal layer is deposited onto a transparent glass substrate and then etched to form a gate bus line and a gate electrode. Next, during a second mask step, a gate insulating layer, an amorphous silicon film, and a doped amorphous silicon film are coated on the transparent glass substrate to form an active layer. Then, a third mask step includes depositing a source/drain metal film onto the glass substrate and patterning the metal film to form source/drain electrodes on the active layer and a data bus line. During a fourth mask step, a passivation film is deposited onto the glass substrate and a contact hole is formed in the passivation film. Then, during a fifth mask step, an ITO transparent film is deposited onto the substrate and etched to form a pixel electrode.

[0008] Since manufacturing costs are dependent upon the total number of masking steps used to fabricate the array substrate, significant consideration has been given to reduce the total number of masking steps. Accordingly, the third and fourth mask steps can be combined to reduce the total number of masking steps to four masking steps. In order to successfully perform the four masks process, a half-tone mask is used to concurrently form the source and drain electrodes and the active layer, wherein a photoresist film is patterned and etched using the half-tone mask. Alternatively, a slit-type mask having a slit pattern with a resolution less than a normal resolution is inserted for an etch in the exposure process of the photoresist film.

[0009] FIGS. 1 to 4 are cross sectional views of a method for fabricating a liquid crystal display device using a four masks process according to the related art. In FIG. 1, a metal film, such as aluminum (Al), chromium (Cr) or the like, is

deposited on a transparent insulating substrate 10 using a sputtering method. Then, a photoresist film is coated onto the metal film and is exposed to light using a first mask to form a photoresist pattern. Next, the metal film is wet-etched using the photoresist pattern as an etch mask to form a gate electrode 1, a gate bus line 21, and a gate pad 11 on the transparent insulating substrate 10. In addition, the gate electrode 1, gate bus line 21, and gate pad 11 may include an additional conductive layer formed exclusively on upper surfaces of the gate electrode 1, gate bus line 21, and gate pad 11

[0010] In FIG. 2, a gate insulating layer 3, an amorphous silicon film (a-Si:H) 5, and an n+ doped amorphous silicon film 7 are sequentially deposited onto the transparent insulating substrate 10. Next, a metal film is deposited on the transparent insulating substrate 10. Then, a photoresist film is coated onto the metal film and is exposed and developed by using a second mask to form a photoresist pattern.

[0011] The second mask includes a slit such that a half-tone pattern is used to form a channel layer region of the amorphous silicon film (a-Si:H) 5. Accordingly, the amount of light irradiated onto the photoresist film through the slit of the second mask is decreased. Thus, the region of the photoresist film corresponding to the region of the slit of the second mask receives only a portion of the irradiated light.

[0012] Then, an etch process is performed to simultaneously form the source electrode 9a, the drain electrode 9b, the data bus line, the data pad 31, the ohmic contact layer 7, and the channel layer 5. In other words, a single masking process enables simultaneous formation of the source electrode 9a, the drain electrode 9b, the data bus line, the data pad 31, the ohmic contact layer 7, and the channel layer 5, thereby decreasing the total number of mask steps.

[0013] In FIG. 3, a passivation film 13 is formed on the transparent insulating substrate 10. Then, contact holes are formed in the passivation film 13 using a third mask step to expose the gate pad 11 and the data pad 31.

[0014] In FIG. 4, a transparent conductive film of ITO is deposited along an entire surface of the transparent insulating substrate 10. Then, a photoresist film is coated onto the ITO film and patterned by using a fourth mask to form the pixel electrode 15, a gate pad pattern 25, and a data pad pattern 27. The pixel electrode 15 is formed to overlap the gate bus line 21 to form an auxiliary capacitance with the gate bus line 21.

[0015] However, as detailed above, manufacturing costs of the LCD devices are considerably higher using a four mask fabrication process than costs associated with a three mask fabrication process. Accordingly, an LCD array substrate fabricated using a three masks process would result in lower costs and increase an overall time to fabricate the LCD array substrate. In addition, since large-sized LCD devices require increasing the lengths of the gate and data bus lines, low resistance wirings are required.

### SUMMARY OF THE INVENTION

[0016] Accordingly, the present invention is directed to a liquid crystal display device and a method of fabricating a liquid crystal display device that substantially obviate one or more problems due to limitations and disadvantages of the related art.

[0017] An object of the present invention is to provide a liquid crystal display device having an increased capacitance and low resistance wiring structure.

[0018] Another object of the present invention is to provide a method for fabricating a liquid crystal display device having a reduced number of mask processes.

[0019] Another object of the present invention is to provide a method for fabricating a liquid crystal display device having a reduced number of chemical treatment processes.

[0020] Additional features and advantages of the invention will be set forth in the description which follows, and in part will be apparent from the description, or may be learned by practice of the invention. The objectives and other advantages of the invention will be realized and attained by the structures particularly pointed out in the written description and claims hereof as well as the appended drawings.

[0021] To achieve these objects and other advantages and in accordance with the purpose of the invention, as embodied and broadly described, a method of fabricating a liquid crystal display device includes forming a gate electrode, a gate bus line, and a gate pad on a substrate using a first mask process, forming a gate insulating layer and an active layer on an entire surface of the substrate, forming a first organic material film on an entire surface of the substrate, removing a portion of the first organic material film to expose a first portion of the gate pad, depositing a transparent film on an entire surface of the substrate, patterning the transparent film using a second half-tone mask to form a data bus line, a source electrode, a drain electrode, a pixel electrode, a channel layer, and an ohmic contact layer, exposing portions of the data pad and data bus line using a third mask, forming a second organic material film on an entire surface of the substrate, depositing a low resistance material on the data bus line, coating a passivation film on the substrate, removing the second organic material film using a lift-off process to expose a second portion of the gate pad and a first portions of the data pad.

[0022] In another aspect, a method of fabricating a liquid crystal display device includes forming a gate electrode, a gate bus line, and a gate pad on a substrate, forming a gate insulating layer, an active layer, and a transparent film on an entire surface of the substrate, patterning the active layer and transparent conductive film to form a data bus line, a data pad, a source electrode, a drain electrode, a pixel electrode, a channel layer, and an ohmic contact layer, forming a passivation layer on an entire surface of the substrate, and exposing portions of the gate and data pads, wherein the data bus line, and the source, drain, and pixel electrodes include the transparent conductive film.

[0023] In another aspect, a liquid crystal display device includes a gate electrode, a gate bus line, and a gate pad on a substrate, a data bus line and data pad on the substrate, a gate insulating layer an entire surface of the substrate, an active layer on a portion of the gate insulating layer, a source electrode, a drain electrode, and a pixel electrode on the active layer, and a low resistance material on the data bus line, wherein the data bus line, the gate and data pads, the source and drain electrodes, and the pixel electrode are formed of transparent conductive material.

[0024] In another aspect, a liquid crystal display device includes a gate bus line on a substrate, a gate insulating layer

formed on the gate bus line, an active layer formed on the gate insulating layer, and an auxiliary capacitor electrode including indium tin oxide film formed exclusively on the active layer.

[0025] It is to be understood that both the foregoing general description and the following detailed description of the present invention are exemplary and explanatory and are intended to provide further explanation of the present invention as claimed.

#### BRIEF DESCRIPTION OF THE DRAWINGS

[0026] The accompanying drawings, which are included to provide a further understanding of the present invention and are incorporated in and constitute a part of this application, illustrate embodiments of the present invention and together with the description serve to explain the principle of the present invention. In the drawings:

[0027] FIGS. 1 to 4 are cross sectional views of a method for fabricating a liquid crystal display device using a four masks process according to the related art;

[0028] FIGS. 5 to 15 are cross sectional and plan views of an exemplary method for fabricating a liquid crystal display device using a three masks process according to the present invention; and

[0029] FIG. 16 is a cross sectional view of an exemplary process for fabricating a liquid crystal display device according to the present invention.

#### DETAILED DESCRIPTION OF THE PREFERRED EMBODIMENTS

[0030] Reference will now be made in detail to a preferred embodiment of the present invention with reference to the accompanying drawings.

[0031] FIGS. 5 to 15 are cross sectional and plan views of an exemplary method for fabricating a liquid crystal display device using a three masks process according to the present invention. In FIG. 5, a metal film, such as aluminum (Al), chromium (Cr) or the like, may be deposited upon a transparent lower substrate 100 using a sputtering method, for example. Then, a photoresist film may be coated onto the metal film and exposed to light using a first mask. Next, the exposed portions of the photoresist film may be developed, thereby forming a photoresist pattern such that a portion of the photoresist film is removed at regions corresponding to a portion of the metal film that is to be etched. Then, the metal film is partly etched by a wet etching process, for example, using the photoresist pattern as an etch mask to form a gate electrode 101, a gate pad 111, and a gate bus line 121 on the transparent lower substrate 100. In addition, the gate electrode 101, gate pad 111, and gate bus line 121 may include an additional conductive layer formed exclusively on upper surfaces of the gate electrode 101, gate pad 111, and gate bus line 121 in order to reduce contact resistance. For example, a silicide material may be formed on the upper surfaces of the gate electrode 101, gate pad 111, and gate bus line 121

[0032] In FIG. 6A, a gate insulating layer 103 is deposited along an entire surface of the transparent lower substrate 100 and the gate electrode 101, the gate pad 111, and the gate bus line 121. Next, an amorphous silicon film (a-Si:H) and an n+

doped amorphous silicon film may be sequentially deposited on the transparent lower substrate **100** to form an active layer **105**. For example, the gate insulating layer **103** and the active layer **105** may be formed using a Plasma Enhanced Chemical Vapor Deposition (PECVD) chamber. Then, a first organic film **200** may be printed onto an entire region of the transparent lower substrate **100**, except for a gate pad region, to form a printed region **501** (in FIG. 6B).

[0033] In FIG. 6B, the printed region **501** may include the first organic film **200**, but the gate pad region may exclude the first organic film **200**. Accordingly, the first organic film **200** may be printed within a region upon which pixel regions may be formed, but may not be printed within regions other than the pixel regions so that the active layer is exposed. Next, the transparent lower substrate **100** may be dry-etched to expose portions of the active layer **105** deposited within the gate pad region.

[0034] In FIG. 7, the printed first organic film **200** may be completely removed and a transparent conductive film **107**, such as Indium Tin Oxide (ITO), may be deposited on an entire surface of the transparent lower substrate **100** using a sputtering method, for example. The ITO film **107** may be used for source, drain, and pixel electrodes of a thin film transistor (TFT) that may be subsequently formed on the transparent lower substrate **100**. Accordingly, the source, drain, and pixel electrodes may be integrally formed on the transparent lower substrate **100**, wherein separate formation of individual contact holes to electrically connect the drain electrode with the pixel electrode may not be necessary.

[0035] In FIG. 8, a photoresist film may be coated on the transparent lower substrate **100** including the ITO film **107**. Then, the photoresist film may be exposed to form a half-tone pattern **300** using a second mask. For example, a first portion of the photoresist film may be partially exposed by a predetermined amount within a channel of the TFT region, a second portion of the photoresist film may not be exposed within source and drain electrode regions, and a third portion of the photoresist film may be fully exposed within a region to be completely etched, thereby forming the half tone pattern **300**.

[0036] In FIG. 9A, the ITO film **107** may be wet-etched using the half-tone pattern **300**, thereby forming a gate pad pattern **132**, a data pad pattern **131**, and a first portion of the ITO film **107** overlaying the TFT region may be removed. Accordingly, second portions of the ITO film **107** may remain within the TFT regions that may be used to form source and drain electrodes **107a** and **108** (in FIG. 10A) on the amorphous silicon (a-Si:H) and n+ doped amorphous silicon films of the active layer **105** and a pixel electrode **108** (in FIG. 10A) that may be continuous with the drain electrode **108** (in FIG. 10A). In addition, a portion of the active layer **105** corresponding to the channel of the TFT region may be partially dry-etched to form an ohmic contact layer and a channel layer within the TFT region, and the half-tone pattern **300** may be removed.

[0037] In FIG. 9B, an auxiliary capacitor electrode **108** may be simultaneously formed on the transparent lower substrate **100** when the second portions of the ITO film **107** are formed. Accordingly, the drain and pixel electrodes **108** (in FIG. 10A) and the auxiliary capacitor electrode **108**, which is separate from the drain and pixel electrodes **108** (in FIG. 10A), may be integrally formed of the ITO film **107**.

[0038] According to the present invention, the drain and pixel electrodes **108** (in FIG. 10A), the auxiliary capacitor electrode **108** (in FIG. 9B), the data bus line (not shown), the data pad **131**, and the source electrode **107a** (in FIG. 10A) may be simultaneously formed together on the same plane after two masking steps. In addition, the source, drain, and pixel electrodes **107a** and **108** (in FIG. 10A) and the auxiliary capacitor electrode **108** (in FIG. 9B) may be formed from a common ITO film.

[0039] Since the pixel electrode **108** (in FIG. 10A), the data bus line (not shown), the data pad **131**, the source electrode **107a** (in FIG. 10A), the drain electrode **108** (in FIG. 10A), and the auxiliary capacitor electrode **108** (in FIG. 9B) are formed from a common ITO film, an auxiliary capacitance demonstrates a characteristic structure. The auxiliary capacitance is configured to have a section structure comprising a gate bus line **121**, a gate insulating layer **103** formed on the gate bus line **121**, an active layer **105** formed on the gate insulating layer **103**, and the ITO film **108** formed on the active layer **105**.

[0040] Furthermore, the active layer **105** may be completely formed on a lower side surface of the ITO pixel electrode **108**. Accordingly, no passivation films or inter-layer step portion are introduced on the lower side surface of the pixel electrode **108**, and the active layer **105** may be provided as a single layer.

[0041] In FIG. 10A, a first passivation film **109** may be deposited on the transparent lower substrate **100** including the source electrode **107a** and the drain and pixel electrodes **108**. Then, using a third masking process, the first passivation film **109** may be patterned to expose a portion of the ITO film overlapping the gate pad **111**, the data pad **131**, the data bus line (not shown), and the source electrode **107a**. The data bus line may transmit image signals to be supplied to the pixel electrode **108** via the TFT within the TFT region. For example, the data bus line (not shown) may be formed of a metallic pattern having a low resistance, since the ITO film may not be suitable for the data bus line due to its relatively high resistance. However, the data bus line may be simultaneously formed with the source electrode **107a** using the ITO film.

[0042] In FIG. 10B, a first region **504** of the first passivation film **109** that corresponds to the data bus line may be removed, and a second region **504** of the first passivation film **109** that corresponds to the gate pad region may be removed.

[0043] In FIG. 11, a second organic film **400** may be provided on the gate pad region and the data pad region using a printing process, for example.

[0044] In FIG. 12A, a metallic pattern, such as copper (Cu), silver (Ag), aurum (Au), titanium (Ti) and tungsten (W), having a low resistance may be deposited on the data bus line **507** (in FIG. 12B), using a plating method, such as electroplating or electroless plating, to form a low resistance data bus line **107b**.

[0045] During the electroless plating method, a copper film may be formed on the ITO source electrode **107a** using a reduction reaction of copper ions in a plating solution, so that the low resistance data bus line **107b** is formed. In addition, the reduction reaction may be accelerated by adding platinum (Pt), a processing temperature may be

within a range of about 20~70° C., and pH may be within a range of about 9.0~13.0. Furthermore, the electroless plating solution may include a mixture of copper sulfate for supplying the copper ion, formalin for supplying electrons, and Rochelle salt for lengthening the life span of the electroless plating solution.

[0046] During the electro-plating method, the data bus line **107b**, upon which the low resistance metal film is being plated, may be charged as a cathode and the low resistance metal film, such as Cu, Ag, Au, Ti and W, may be charged as an anode. Then, the transparent lower substrate **100** is dipped in an electrolyte solution containing ions of the low resistance metal film to be plated, and a voltage is supplied between the anode and cathode. Accordingly, the low resistance metal may be coated only on the data bus line **507** (in **FIG. 12B**), which is an ITO film, and may not be coated on the passivation film **109**.

[0047] In **FIG. 12B**, a second organic film printed region **506** may be covered with the second organic film **400** (in **FIG. 12A**), and the metal film may not be plated within the data and gate pad regions.

[0048] In **FIG. 13A**, a second passivation film **119**, such as SiN<sub>x</sub>, may be deposited on an entire surface of the transparent lower substrate **100** including the gate and data pad patterns **132** and **131** upon which the second organic film **400** is printed. The second passivation film **119** may be deposited for protecting the data bus line **107b** from external impact, and may be deposited on the second organic film **400**.

[0049] In **FIG. 13B**, the second organic film printed region **506** is covered with the second organic film **400**.

[0050] In **FIG. 14**, the transparent lower substrate **100** may be dipped into a solution for dissolving the second organic film **400**. Accordingly, since the second passivation film **119** does not react with the solution, only first portions of the second passivation film **119** overlying the second organic film **400** may be removed with the second organic film **400**. Thus, the gate pad and data pad patterns **132** and **131** may be exposed.

[0051] In **FIG. 15**, second portions of the second passivation film **119** overlying the TFT and Cst regions may remain on the first passivation film **109**.

[0052] **FIG. 16** is a cross sectional view of an exemplary process for fabricating a liquid crystal display device according to the present invention. Processes for fabricating the liquid crystal display device may include the processes shown in **FIGS. 5-9**, but may include forming the data bus line from the ITO film used to form the source, drain, pixel, and auxiliary capacitor electrodes. In **FIG. 16**, the passivation film **109** may cover and passivate an upper side surface of the data bus line formed together with the pixel electrode **107a** and the pixel electrode **108**.

[0053] It will be apparent to those skilled in the art that various modifications and variations can be made in the liquid crystal display device and method of fabricating a liquid crystal display device of the present invention without departing from the spirit or scope of the invention. Thus, it is intended that the present invention covers the modifications and variations of this invention provided they come within the scope of the appended claims and their equivalents.

What is claimed is:

1. A method of fabricating a liquid crystal display device, comprising the steps of:

forming a gate electrode, a gate bus line, and a gate pad on a substrate using a first mask process;

forming a gate insulating layer and an active layer on an entire surface of the substrate;

forming a first organic material film on an entire surface of the substrate;

removing a portion of the first organic material film to expose a first portion of the gate pad;

depositing a transparent film on an entire surface of the substrate;

patterning the transparent film using a second half-tone mask to form a data bus line, a source electrode, a drain electrode, a pixel electrode, a channel layer, and an ohmic contact layer;

exposing portions of the data pad and data bus line using a third mask;

forming a second organic material film on an entire surface of the substrate;

depositing a low resistance material on the data bus line; coating a passivation film on the substrate;

removing the second organic material film using a lift-off process to expose a second portion of the gate pad and a first portions of the data pad.

2. The method according to claim 1, wherein the pixel electrode, the source electrode, the drain electrode, and the data bus line are simultaneously formed on the active layer.

3. The method according to claim 1, wherein the transparent electrode material includes indium tin oxide.

4. The method according to claim 1, wherein the low resistance material includes at least one of Cu, Ag, Au, Ti, and W.

5. The method according to claim 1, wherein the step of depositing a low resistance material includes one of an electrical plating method and an electroless plating method.

6. The method according to claim 1, wherein the step of removing a portion of the first organic material film includes an etching process.

7. A method of fabricating a liquid crystal display device, comprising the steps of:

forming a gate electrode, a gate bus line, and a gate pad on a substrate;

forming a gate insulating layer, an active layer, and a transparent film on an entire surface of the substrate;

patterning the active layer and transparent conductive film to form a data bus line, a data pad, a source electrode, a drain electrode, a pixel electrode, a channel layer, and an ohmic contact layer;

forming a passivation layer on an entire surface of the substrate; and

exposing portions of the gate and data pads,

wherein the data bus line, and the source, drain, and pixel electrodes include the transparent conductive film.

8. The method according to claim 7, wherein the step of patterning the active layer and the transparent conductive film includes a half-tone mask.

9. The method according to claim 7, wherein the transparent conductive film includes indium tin oxide.

10. The method according to claim 7, further comprising the step of forming an organic material film on the gate and data pads before the step of forming a passivation layer.

11. The method according to claim 10, wherein the step of exposing the gate and data pads includes removing the organic material film using a lift-off method.

12. The method according to claim 7, further comprising a step of forming a low resistance metal on the source electrode before the step of exposing the gate and data pads.

13. The method according to claim 12, wherein the low resistance metal includes at least one of Cu, Ag, Au, Ti, and W.

14. A liquid crystal display device, comprising:

a gate electrode, a gate bus line, and a gate pad on a substrate;

a data bus line and data pad on the substrate;

a gate insulating layer an entire surface of the substrate;

an active layer on a portion of the gate insulating layer;

a source electrode, a drain electrode, and a pixel electrode on the active layer; and

a low resistance material on the data bus line,

wherein the data bus line, the gate and data pads, the source and drain electrodes, and the pixel electrode are formed of transparent conductive material.

15. The device according to claim 14, further comprising an auxiliary capacitor including the gate bus line, the gate insulating film, the active layer, and the transparent conductive material.

16. The device according to claim 14, wherein drain and pixel electrodes are integrally formed along a direction of the gate line.

17. A liquid crystal display device, comprising:

a gate bus line on a substrate;

a gate insulating layer formed on the gate bus line;

an active layer formed on the gate insulating layer; and

an auxiliary capacitor electrode including indium tin oxide film formed exclusively on the active layer.

18. The device according to claim 17, further comprising a data bus line on the substrate.

19. The device according to claim 18, wherein the data bus line includes the indium tin oxide film.

\* \* \* \* \*

专利名称(译)	液晶显示装置及其制造方法		
公开(公告)号	<a href="#">US20040125313A1</a>	公开(公告)日	2004-07-01
申请号	US10/725055	申请日	2003-12-02
[标]申请(专利权)人(译)	乐金显示有限公司		
申请(专利权)人(译)	LG.PHILIPS LCD CO. , LTD.		
当前申请(专利权)人(译)	LG DISPLAY CO. , LTD.		
[标]发明人	LIM BYOUNG HO		
发明人	LIM, BYOUNG HO		
IPC分类号	G02F1/1343 G02F1/133 G02F1/1345 G02F1/136 G02F1/1362 H01L21/02		
CPC分类号	G02F1/136286 G02F2001/136231 Y10S438/951 G02F2001/136295 G02F2001/136236 G02F1/13458		
优先权	1020020086560 2002-12-30 KR		
其他公开文献	US7315344		
外部链接	<a href="#">Espacenet</a> <a href="#">USPTO</a>		

摘要(译)

一种制造液晶显示装置的方法，包括使用第一掩模工艺在基板上形成栅电极，栅极总线 and 栅极焊盘，在基板的整个表面上形成栅极绝缘层和有源层，在基板的整个表面上形成第一有机材料膜，去除第一有机材料膜的一部分以暴露栅极焊盘的第一部分，在基板的整个表面上沉积透明膜，使用图案化透明膜第二半色调掩模，用于形成数据总线，源电极，漏电极，像素电极，沟道层和欧姆接触层，使用第三掩模曝光数据焊盘和数据总线的部分，在基板的整个表面上形成第二有机材料膜，在数据总线上沉积低电阻材料，在基板上涂覆钝化膜，使用升降机移除第二有机材料膜以暴露栅极焊盘的第二部分和数据焊盘的第一部分。

