



(19) **United States**

(12) **Patent Application Publication**
Kawashima et al.

(10) **Pub. No.: US 2010/0060813 A1**
(43) **Pub. Date: Mar. 11, 2010**

(54) **LIQUID CRYSTAL DISPLAY**

(57) **ABSTRACT**

(76) Inventors: **Yuki Kawashima**, Osaka (JP);
Yasutoshi Tasaka, Osaka (JP)

In a vertical alignment mode liquid crystal display device, orientation control with an oblique electric field is stably performed, and decrease in light transmittance is suppressed without much increase in the number of production steps.

Correspondence Address:
NIXON & VANDERHYE, PC
901 NORTH GLEBE ROAD, 11TH FLOOR
ARLINGTON, VA 22203 (US)

A liquid crystal display device according to the present invention includes a first substrate, a second substrate provided so as to oppose the first substrate, and a vertical-alignment type liquid crystal layer provided between the first substrate and the second substrate, and has a plurality of pixels each including: a switching element which is provided on the first substrate and at least includes a semiconductor layer; a pixel electrode electrically connected to the switching element; a counter electrode opposing the pixel electrode; and the liquid crystal layer interposed between the pixel electrode and the counter electrode. The pixel electrode includes at least one recessed portion (or aperture) formed at a predetermined position in the pixel, and in each of the plurality of pixels, when at least a predetermined voltage is applied across the liquid crystal layer, a plurality of regions are created where liquid crystal molecules tilt in respectively different azimuthal directions. The first substrate includes an auxiliary electrode to which a different potential from that for the pixel electrode is applied. The auxiliary electrode includes a portion overlapping the recessed portion (or aperture) of the pixel electrode, and is made of the same film as the semiconductor layer of the switching element.

(21) Appl. No.: **12/519,447**

(22) PCT Filed: **Nov. 30, 2007**

(86) PCT No.: **PCT/JP2007/073231**

§ 371 (c)(1),
(2), (4) Date: **Jun. 16, 2009**

(30) **Foreign Application Priority Data**

Dec. 18, 2006 (JP) 2006-339795

Publication Classification

(51) **Int. Cl.**
G02F 1/1343 (2006.01)

(52) **U.S. Cl.** 349/39; 349/143

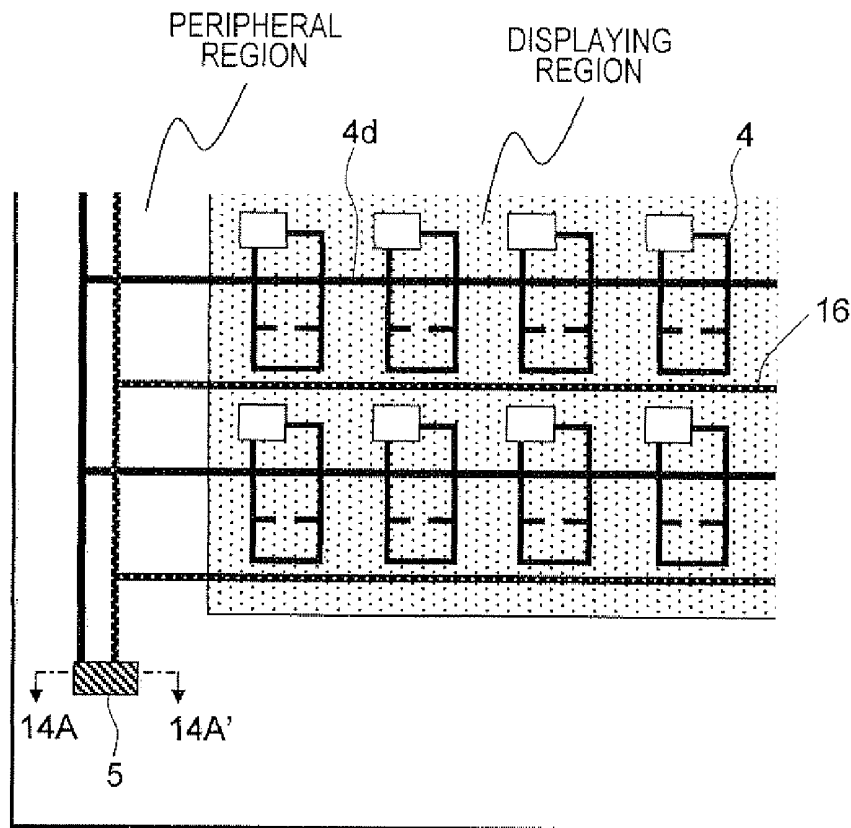

FIG. 1

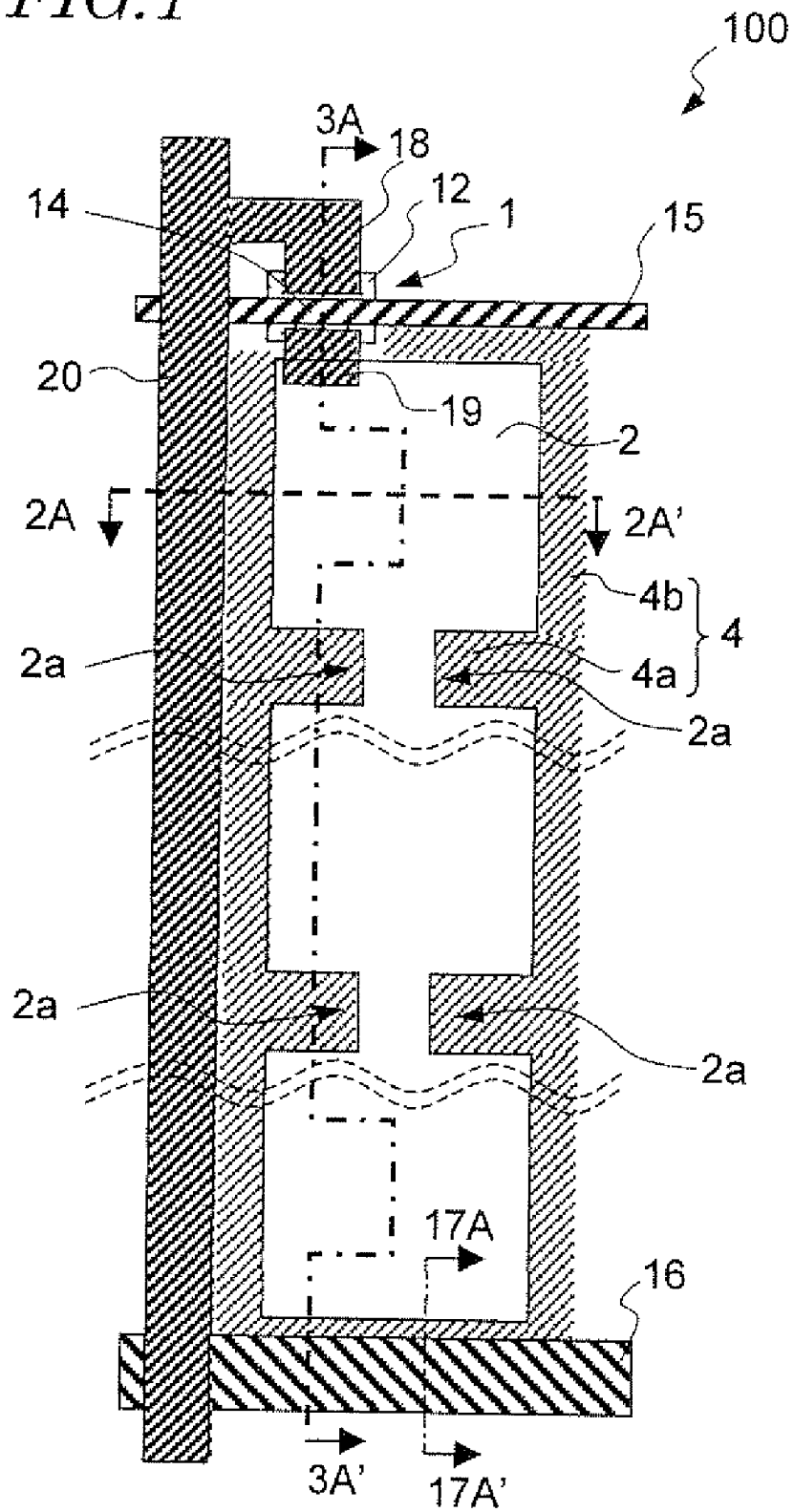

FIG. 2

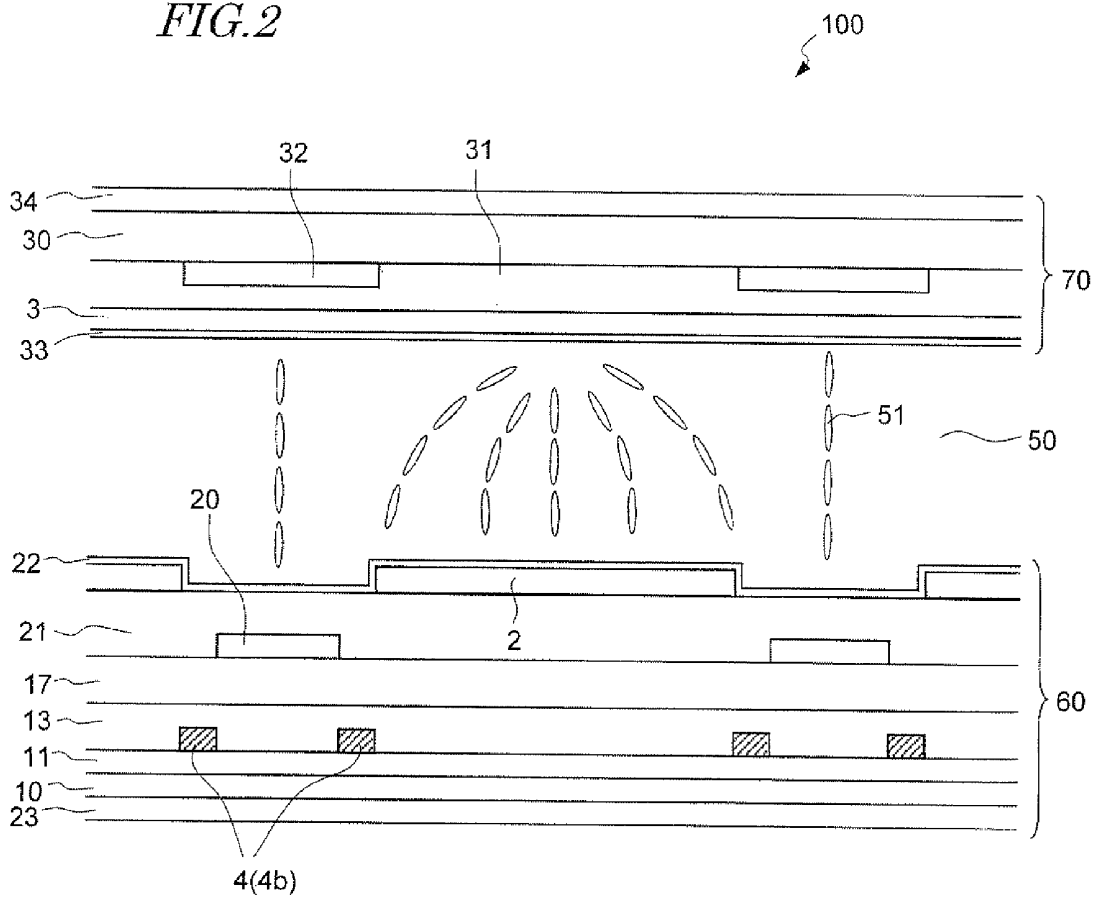

FIG. 3

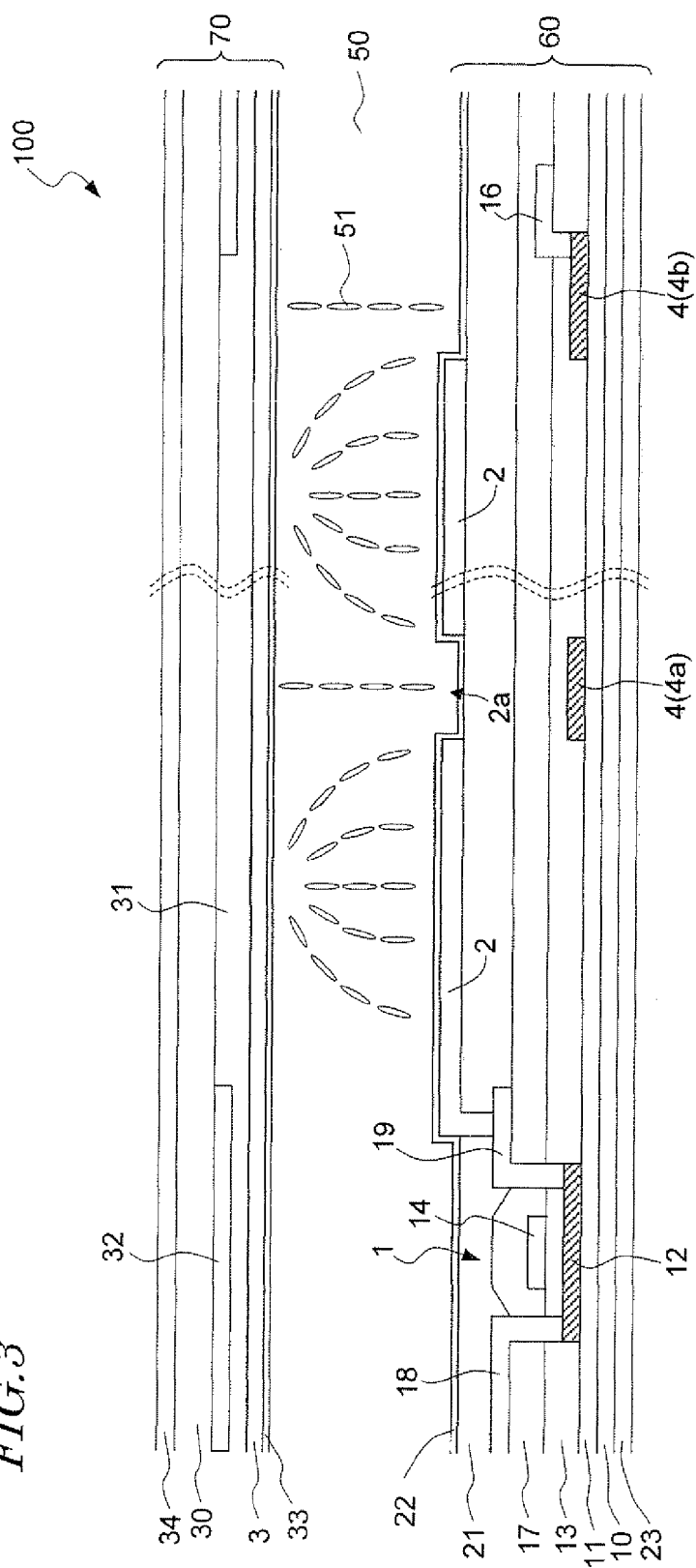

FIG. 4

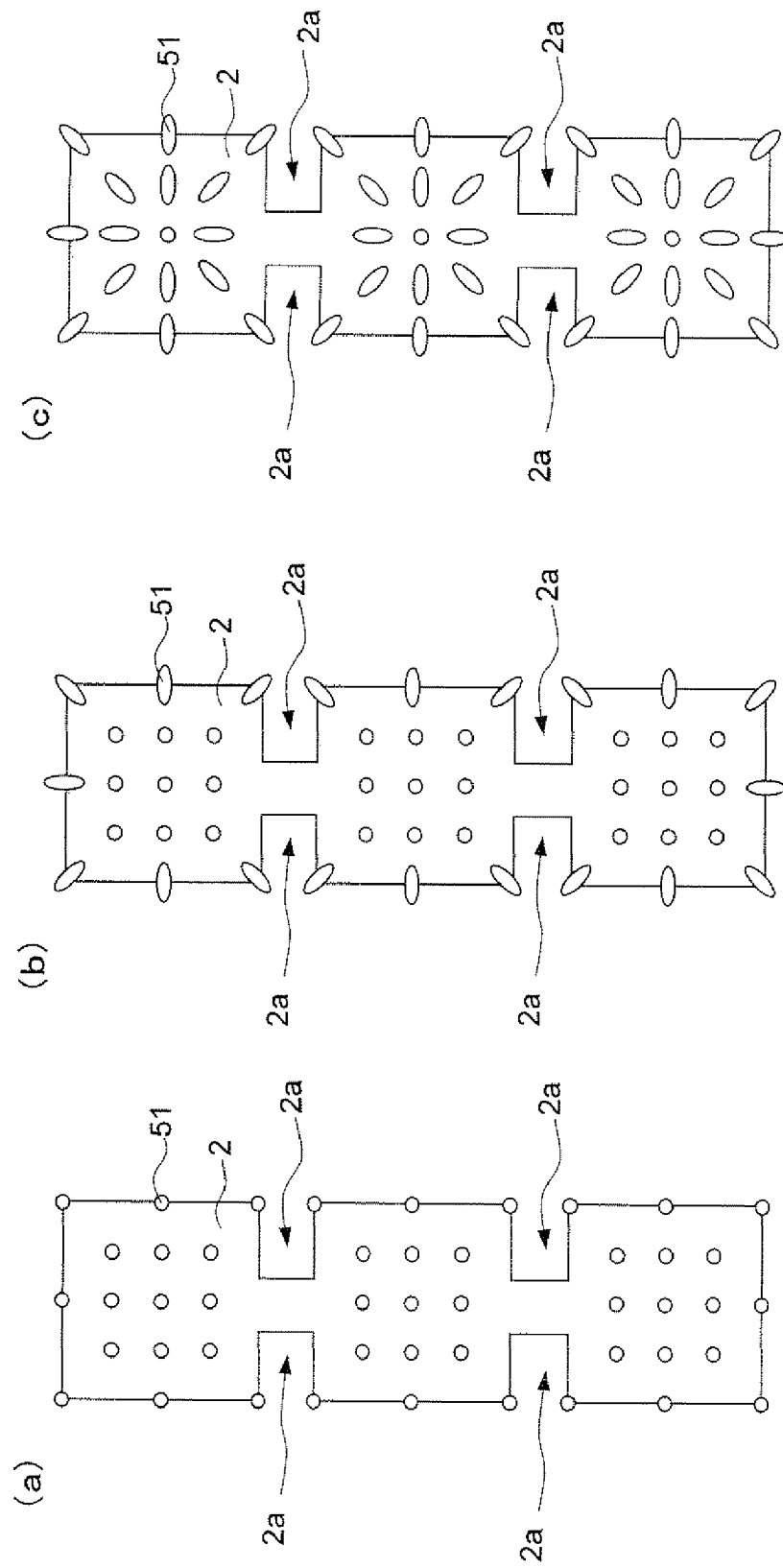

FIG. 5

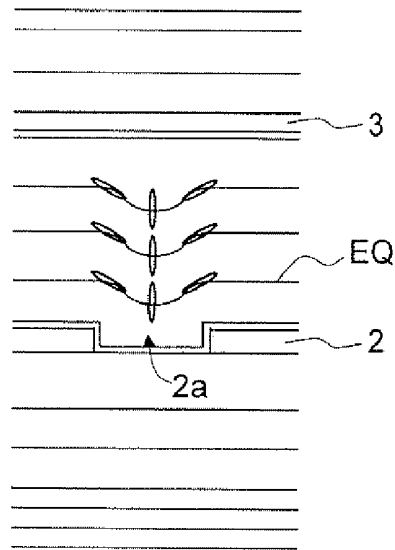

FIG. 6

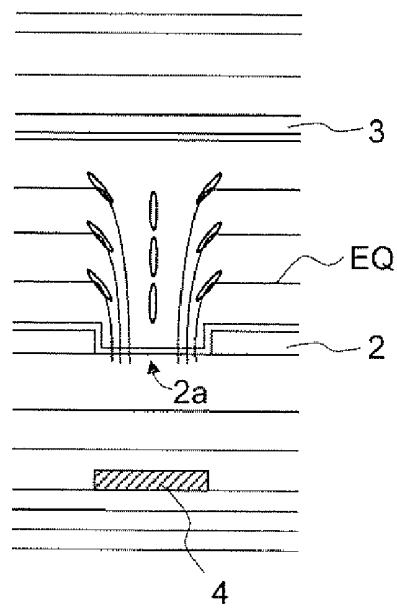

FIG. 7

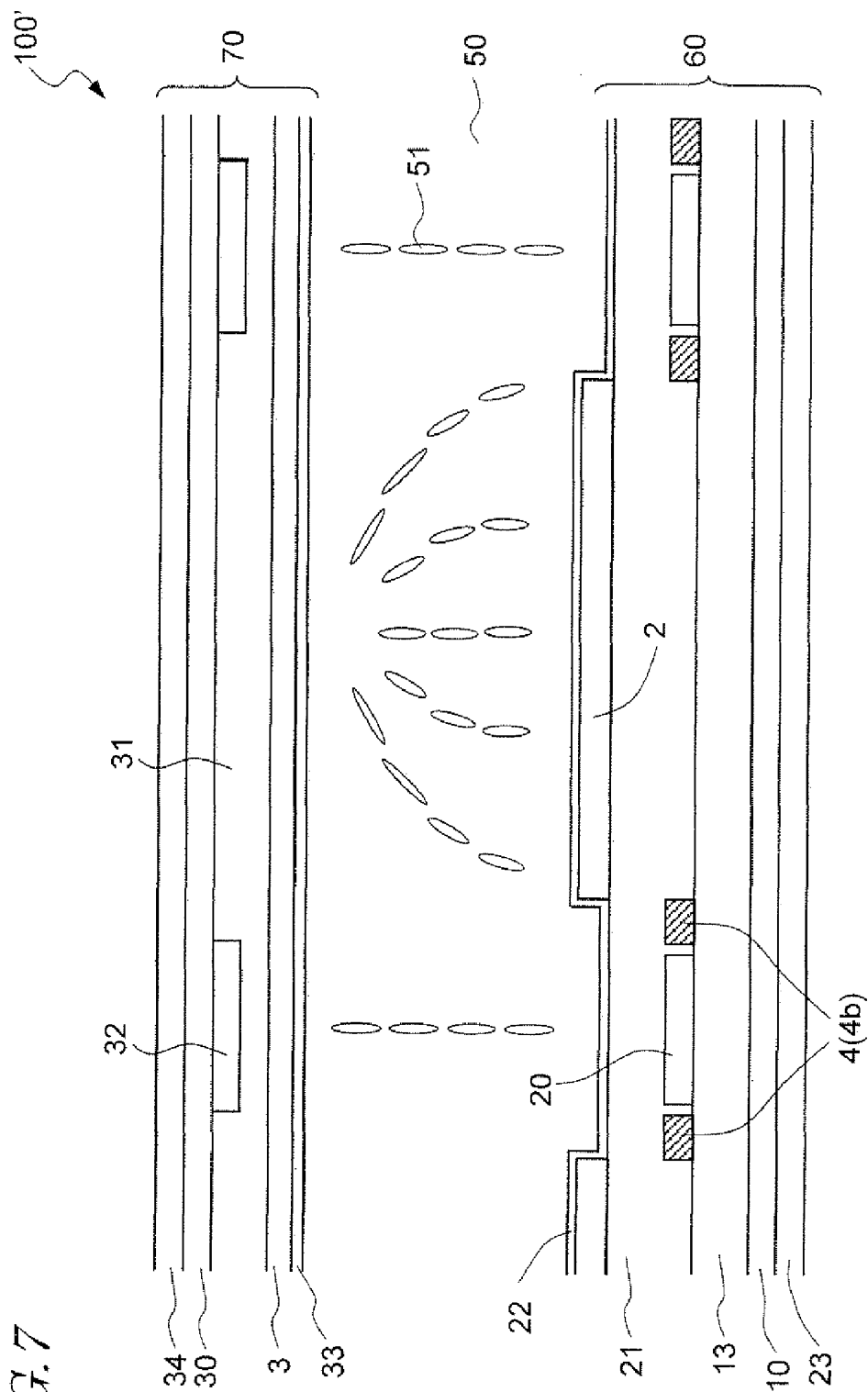

FIG. 9

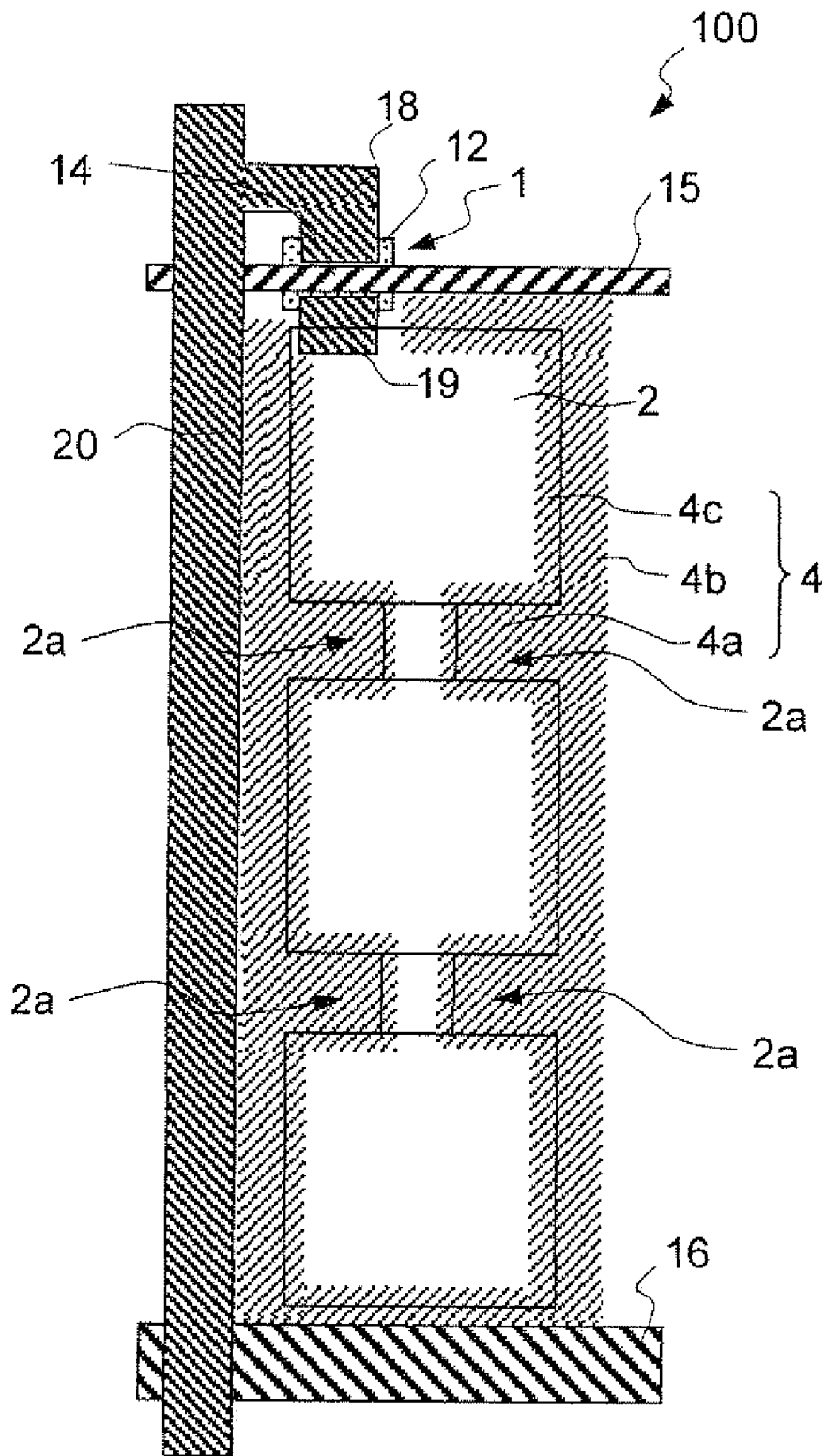

FIG. 10

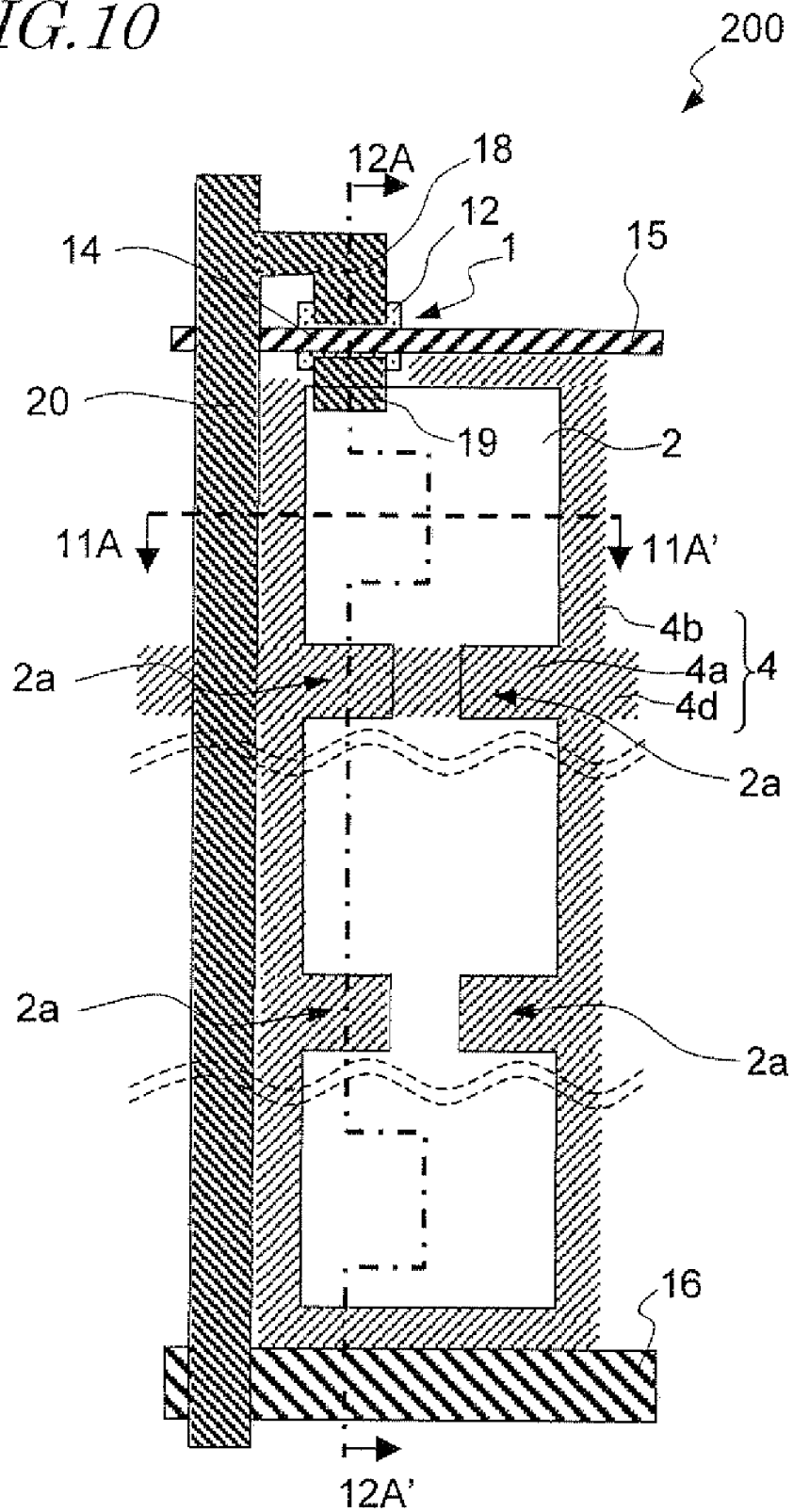

FIG. 11

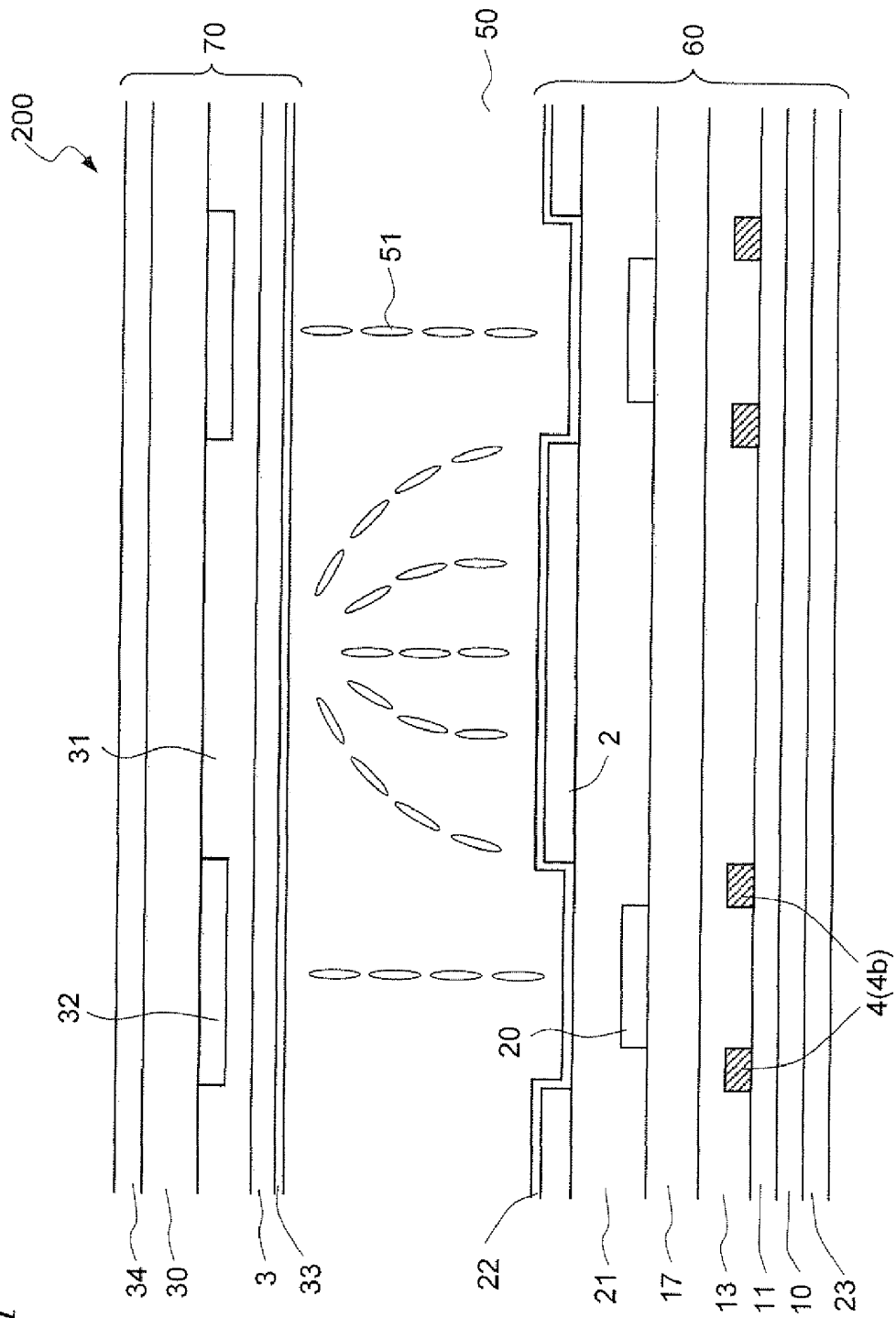

FIG. 12

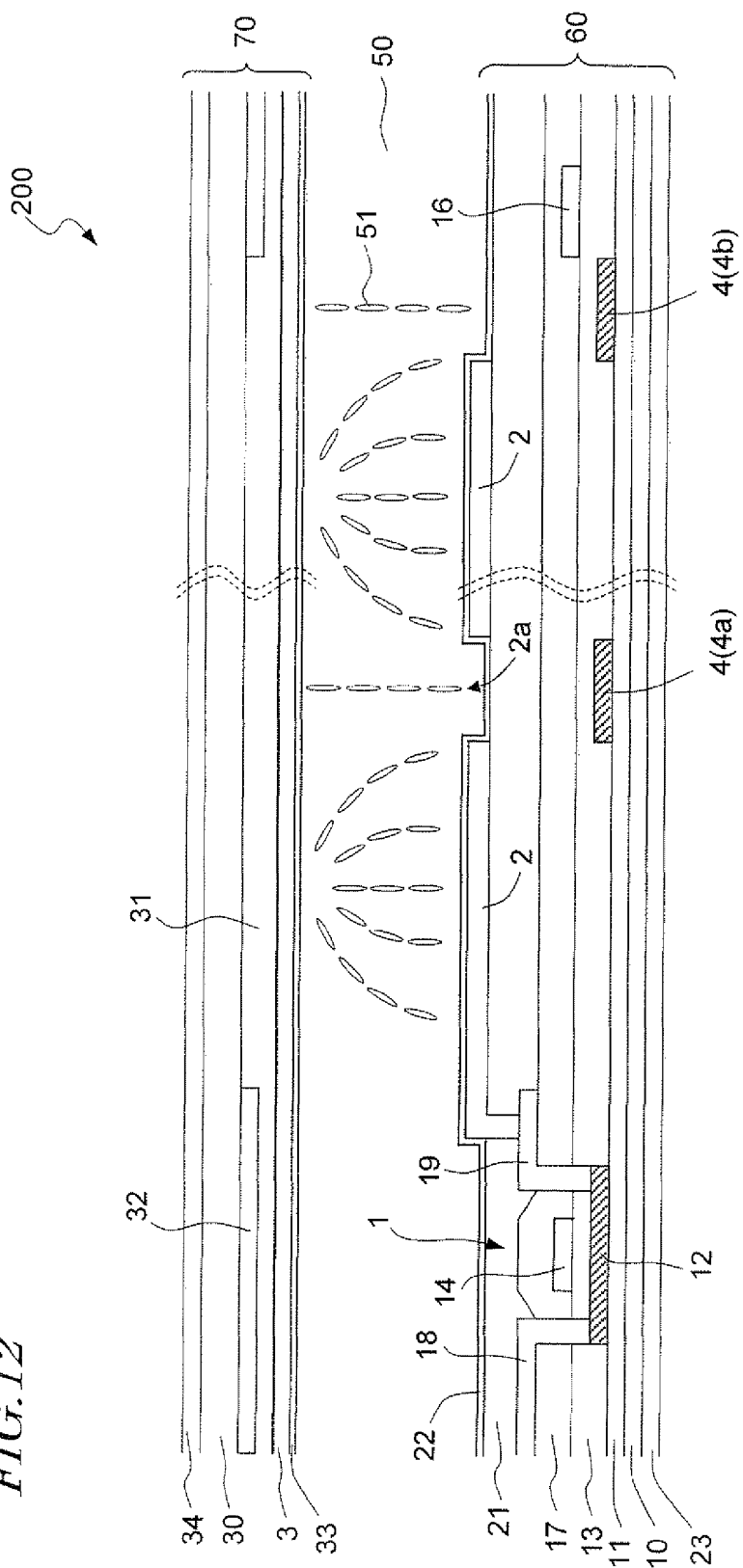

FIG. 13

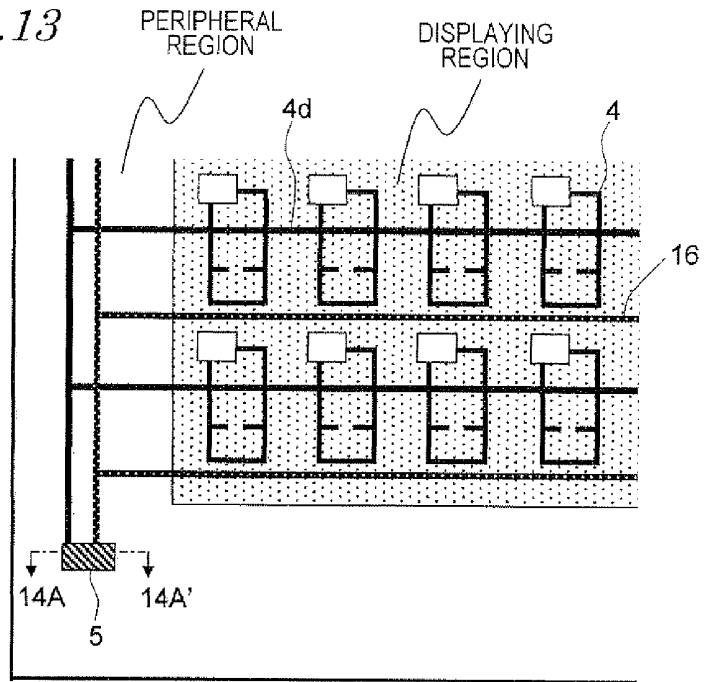
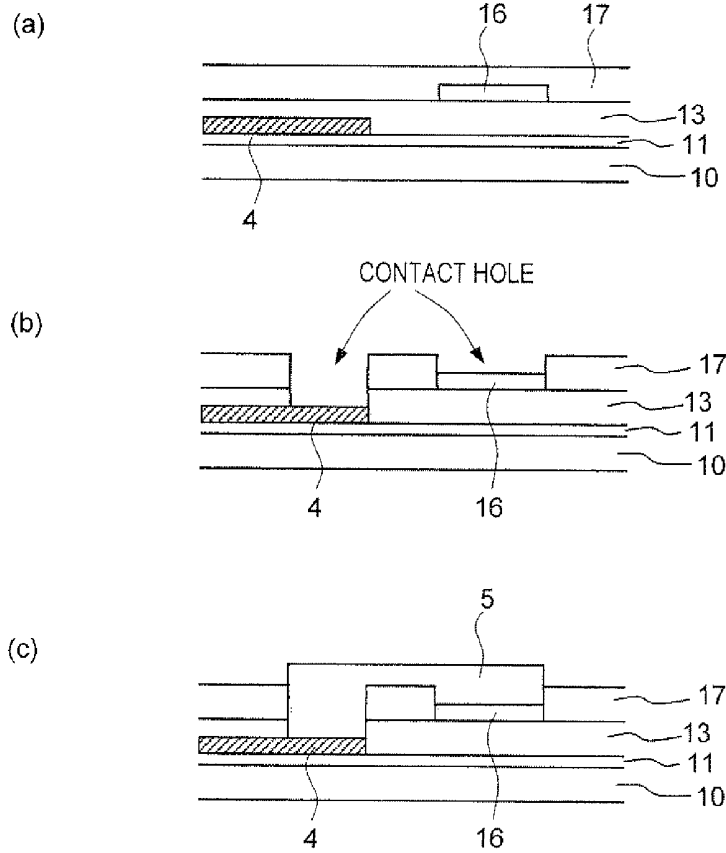

FIG. 14



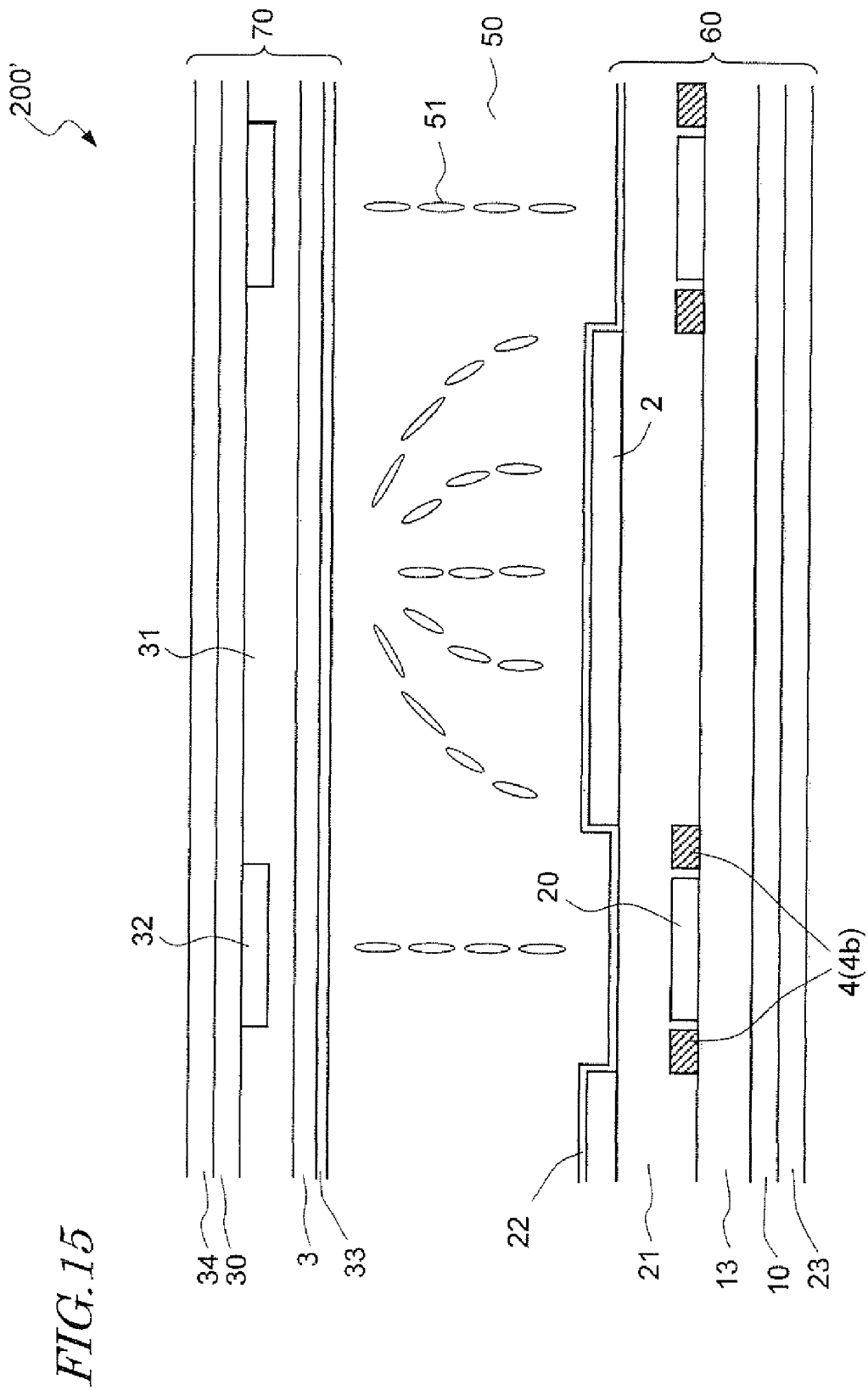

FIG. 16

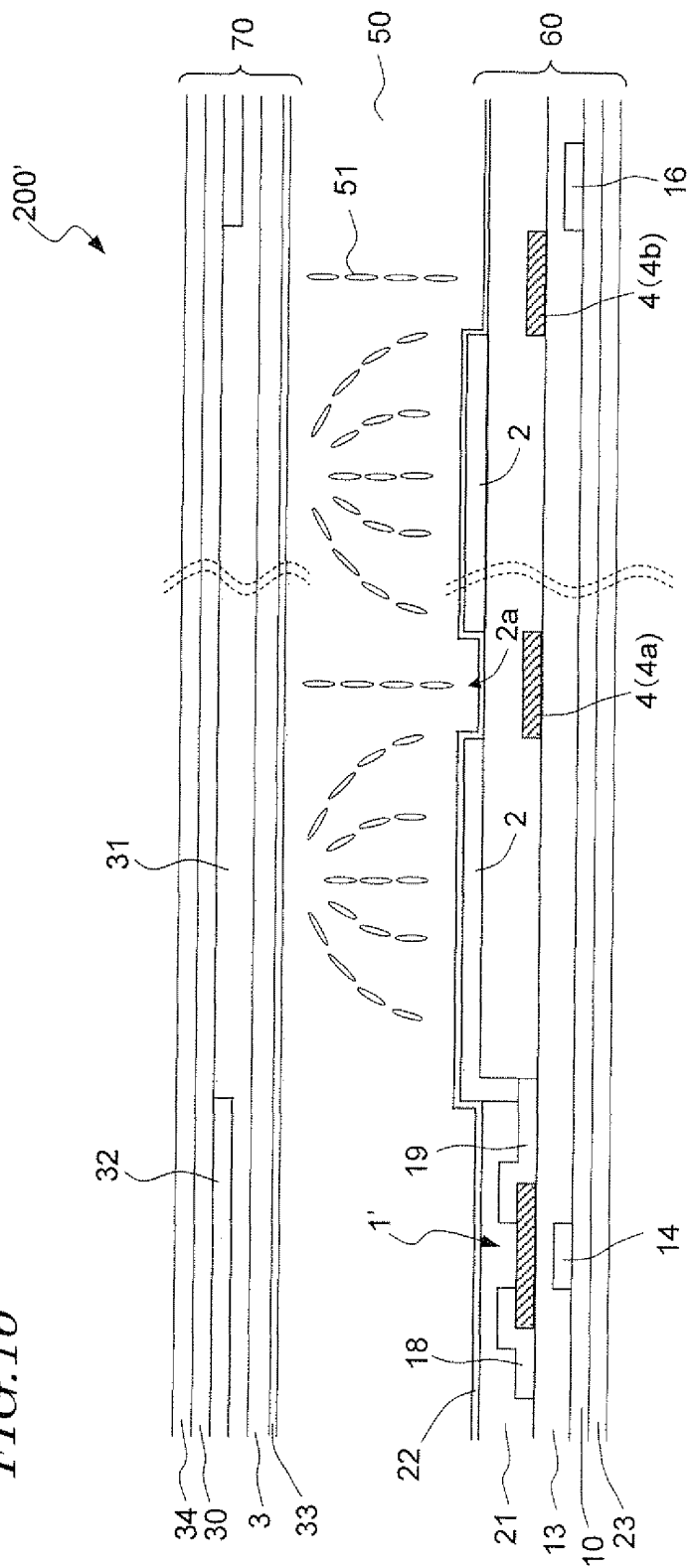

FIG. 17

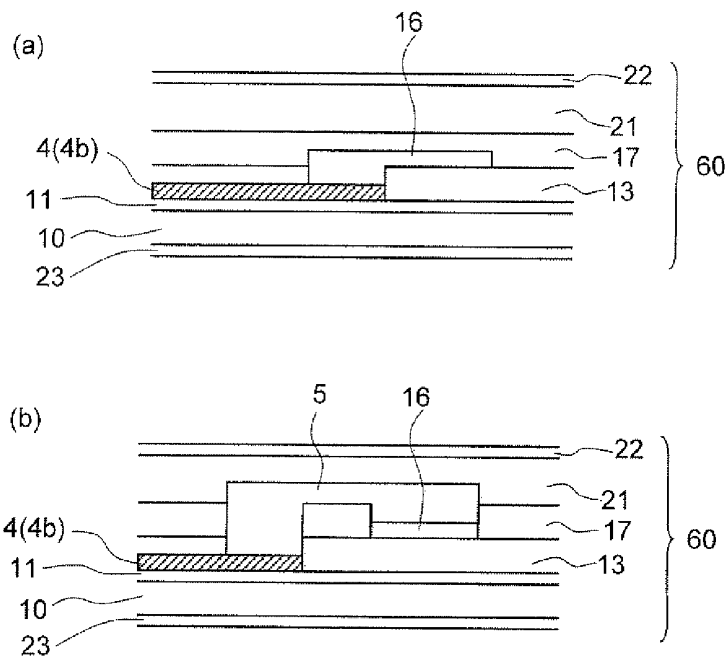

FIG. 18

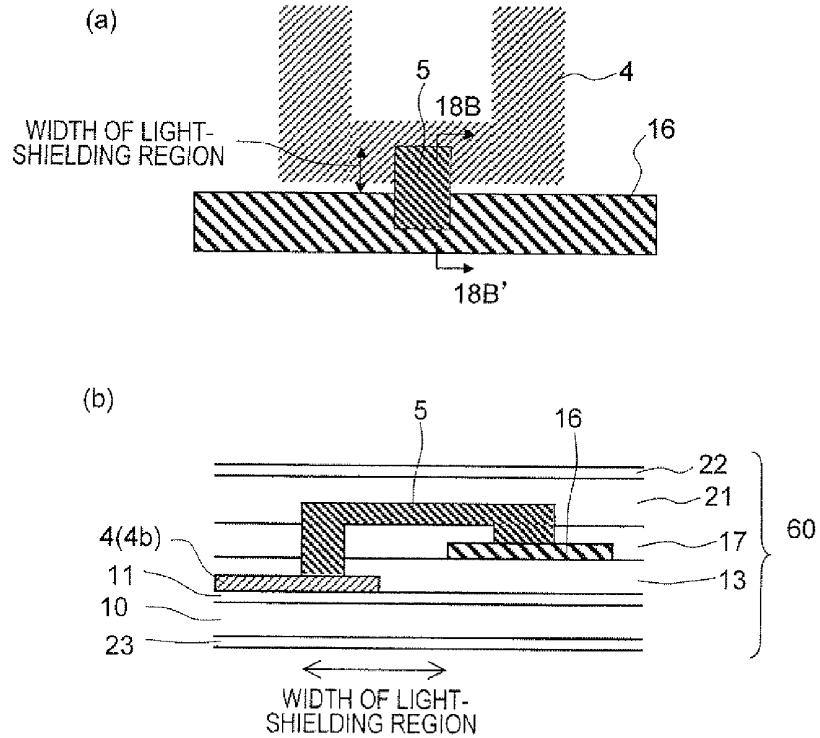

FIG. 19

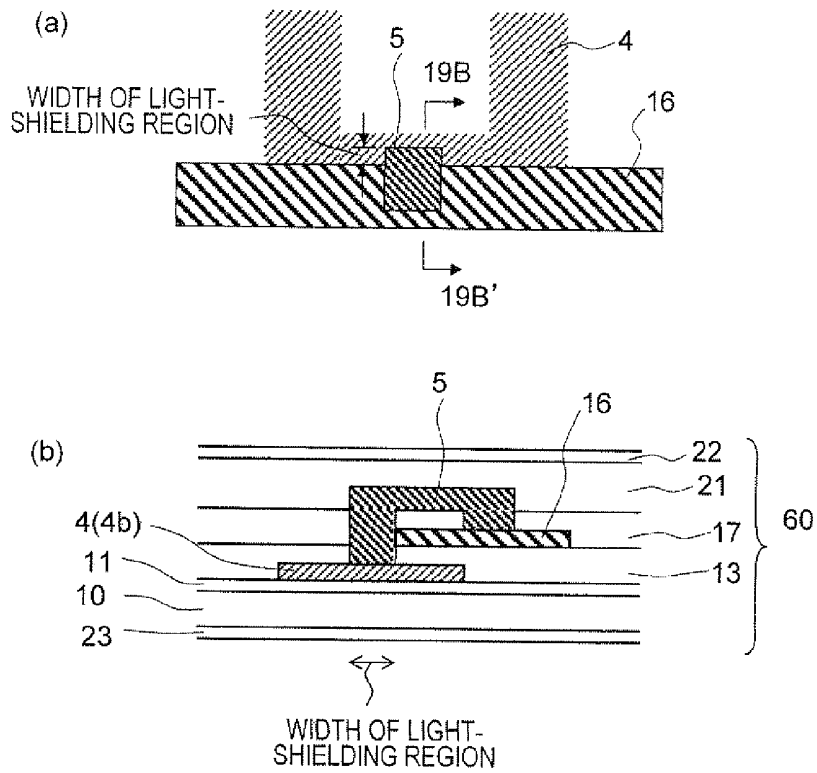

FIG. 20

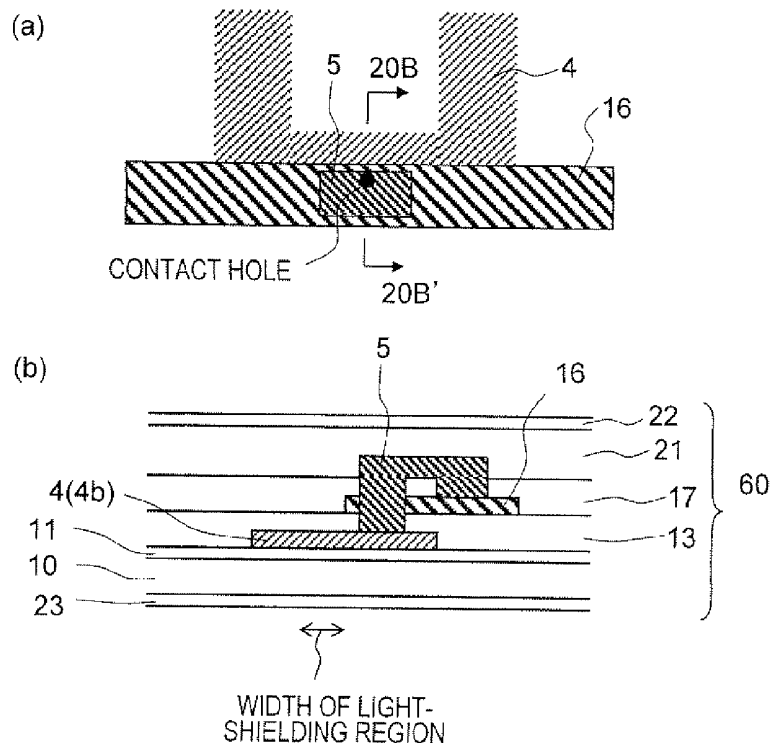

FIG. 21

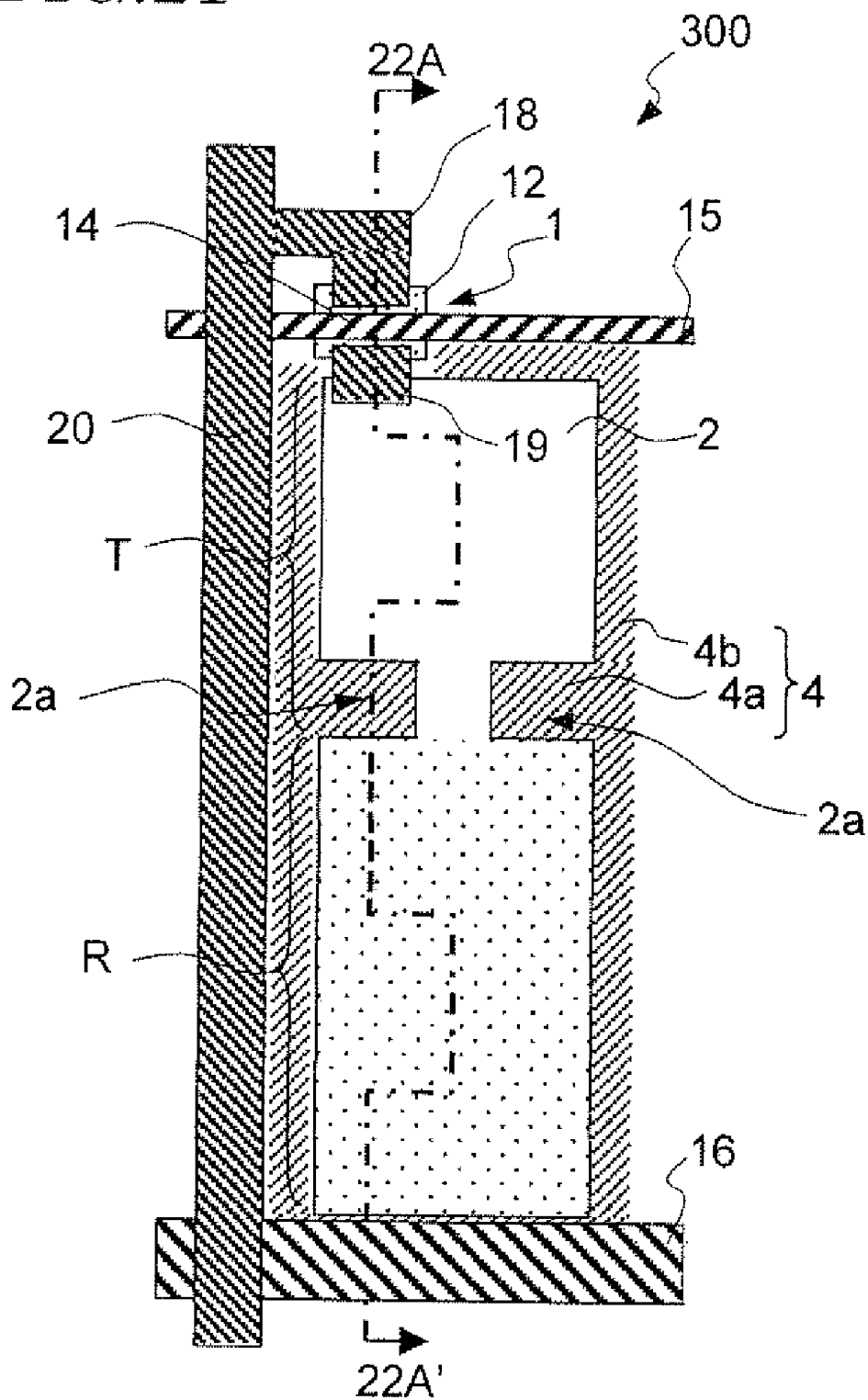

FIG. 22

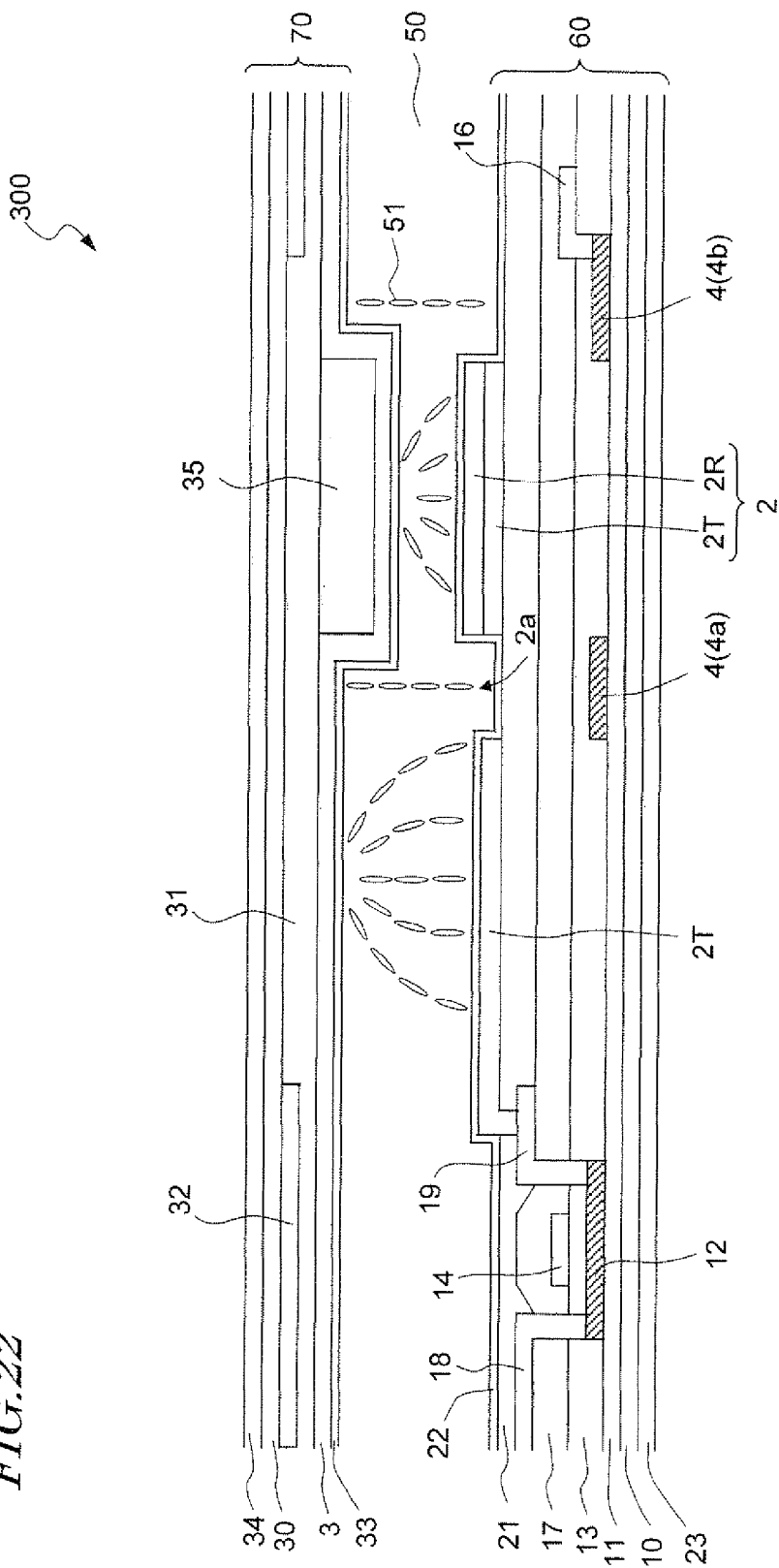

FIG. 23

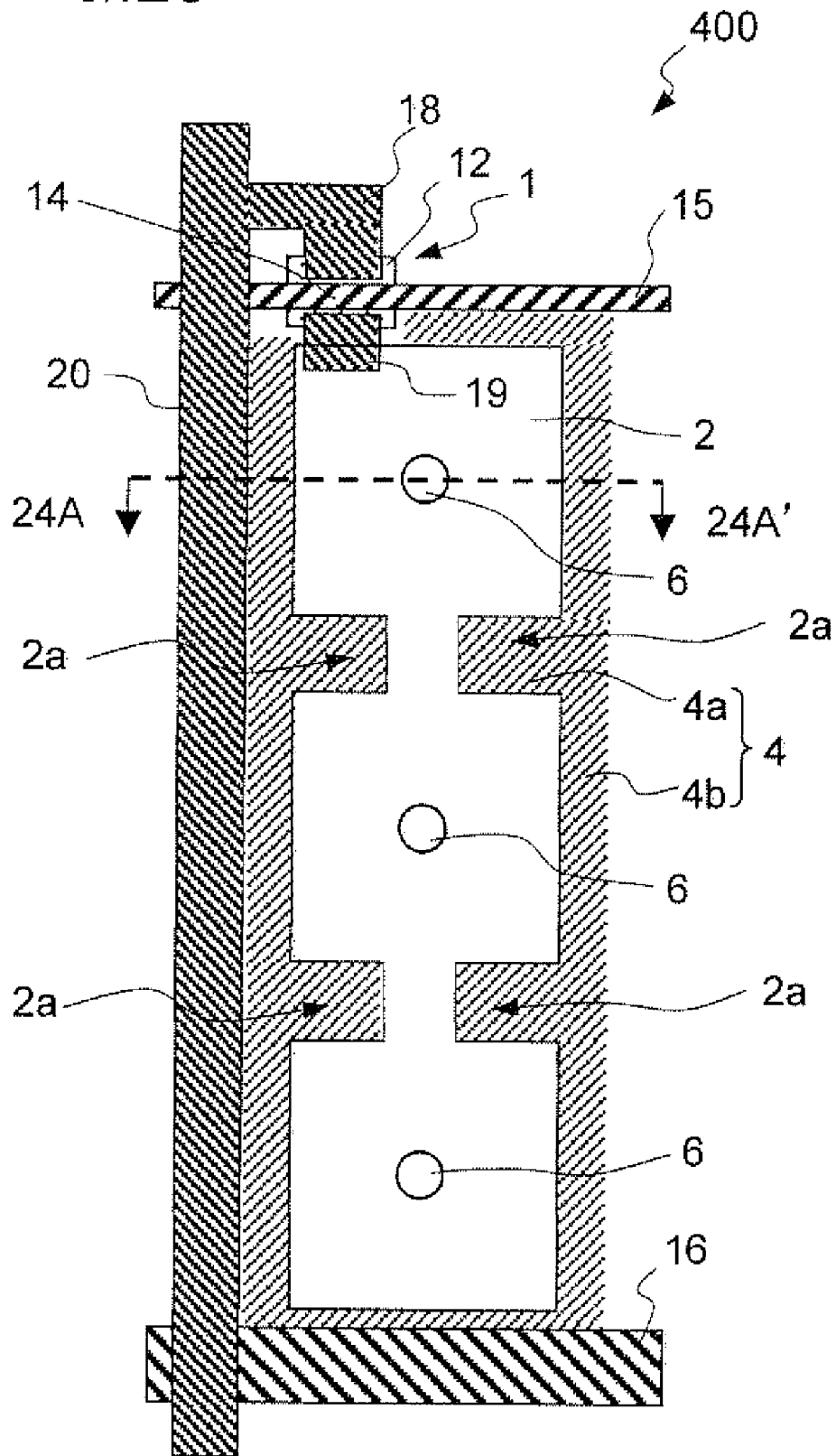
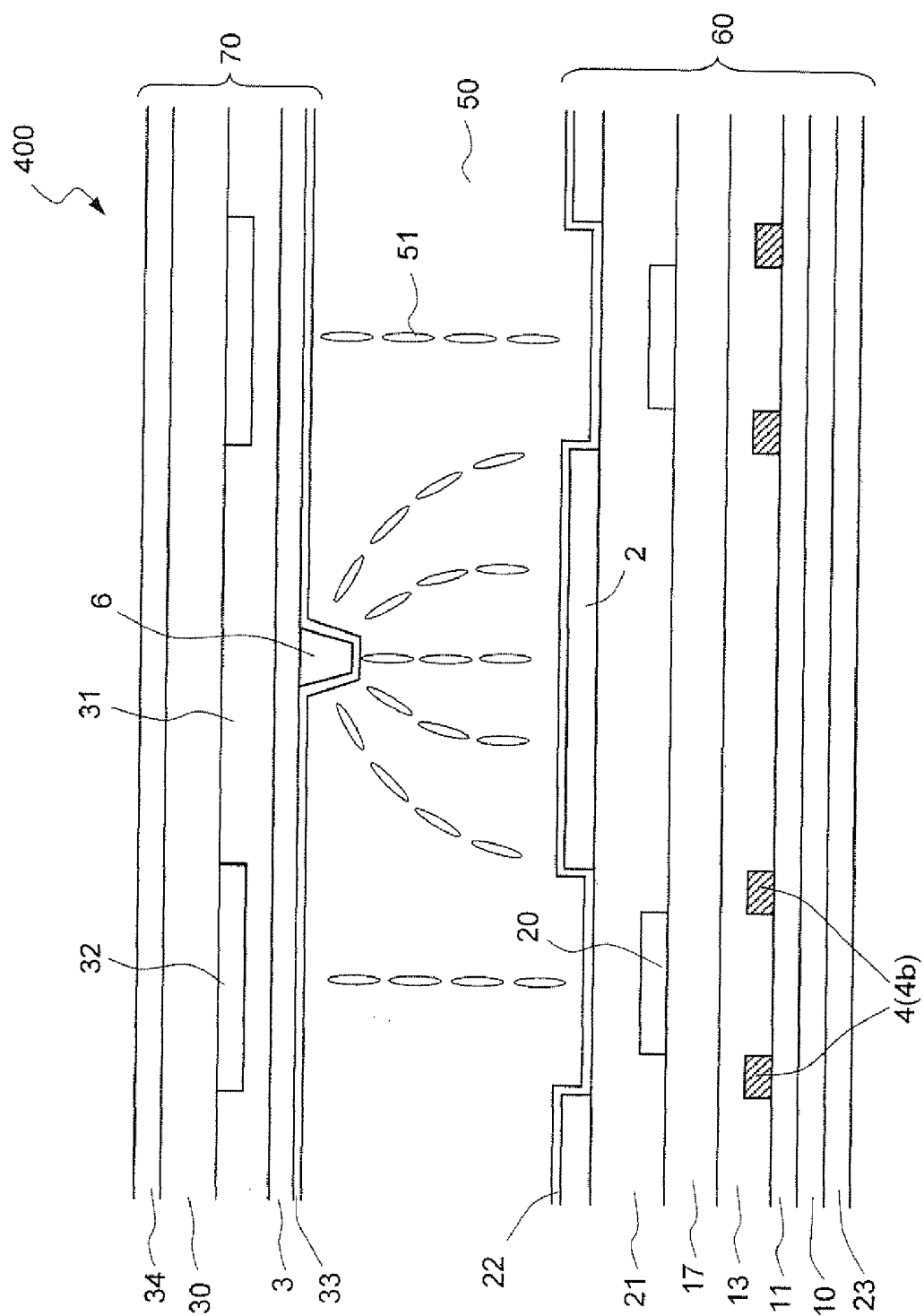

FIG. 24



LIQUID CRYSTAL DISPLAY

TECHNICAL FIELD

[0001] The present invention relates to a liquid crystal display device, and in particular to a liquid crystal display device which is suitably used in mobile information terminals (e.g., PDAs), mobile phones, liquid crystal displays for vehicle mounting, digital cameras, personal computers, amusement devices, television sets, and the like.

BACKGROUND ART

[0002] In recent years, on the strength of being thin and having a low power consumption, liquid crystal display devices are broadly used in laptop-type personal computers, mobile phones, information devices such as electronic organizers, camera-integrated VTRs having a liquid crystal monitor, and the like.

[0003] As a display mode which can realize a high contrast and a wide viewing angle, a vertical alignment mode utilizing a vertical-alignment type liquid crystal layer is drawing attention. In general, a vertical-alignment type liquid crystal layer is formed by using a liquid crystal material having negative dielectric anisotropy and vertical alignment films.

[0004] For example, Patent Document 1 discloses a liquid crystal display device whose viewing angle characteristics are improved by allowing an oblique electric field to be generated near an aperture that is provided in a counter electrode, and around a liquid crystal molecule within the aperture which is in a vertical alignment state, allowing the surrounding liquid crystal molecules to take an inclined orientation.

[0005] However, with the construction described in Patent Document 1, it is difficult to form an oblique electric field across the entire region within the pixel. This leads to a problem in that regions in which the liquid crystal molecules have a slow response to voltage occur within the pixel, thus causing an afterimage phenomenon.

[0006] In order to solve this problem, Patent Document 2 discloses a technique in which, regularly-arranged apertures are provided in the pixel electrode or the counter electrode to form a plurality of liquid crystal domains exhibiting axisymmetric orientation within the pixel.

[0007] Furthermore, Patent Document 3 discloses a technique of providing an auxiliary electrode for stably performing orientation control with an oblique electric field on an active matrix substrate. This auxiliary electrode is provided in a position corresponding to a slit which is formed in a pixel electrode. Moreover, this auxiliary electrode is formed integrally with a storage capacitor electrode for constituting a storage capacitor, and is formed concurrently with and from the same metal film as the gate lines, in a step of forming the gate lines.

[0008] [Patent Document 1] Japanese Laid-Open Patent Publication No. 6-301036

[0009] [Patent Document 2] Japanese Laid-Open Patent Publication No. 2000-47217

[0010] [Patent Document 3] Japanese Laid-Open Patent Publication No. 2006-184334

DISCLOSURE OF INVENTION

Problems to be Solved by the Invention

[0011] However, since the auxiliary electrode disclosed in Patent Document 3 is made of a metal film, it lowers the

aperture ratio of the pixel and decreases light transmittance. In order to solve this problem, it may be possible to compose the auxiliary electrode from a transparent ITO film. In this case, however, extra steps such as deposition and patterning of an ITO film (which needs to be separately formed in addition to the ITO film for composing the pixel electrode) must be provided, thus resulting in an increased number of steps.

[0012] The present invention has been made in view of the above problems, and an objective thereof is to stably perform orientation control with an oblique electric field in a liquid crystal display device of the vertical alignment mode, and suppress decrease in light transmittance without much increase in the number of production steps.

Means for Solving the Problems

[0013] A liquid crystal display device according to the present invention is a liquid crystal display device comprising a first substrate, a second substrate provided so as to oppose the first substrate, and a vertical-alignment type liquid crystal layer provided between the first substrate and the second substrate, the liquid crystal display device having a plurality of pixels each including: a switching element which is provided on the first substrate and at least includes a semiconductor layer; a pixel electrode electrically connected to the switching element; a counter electrode opposing the pixel electrode; and the liquid crystal layer interposed between the pixel electrode and the counter electrode, the pixel electrode including at least one aperture or recessed portion formed at a predetermined position in the pixel, and in each of the pixels, when at least a predetermined voltage is applied across the liquid crystal layer, a plurality of regions being created where liquid crystal molecules tilt in respectively different azimuthal directions, wherein, the first substrate includes an auxiliary electrode to which a different potential from that for the pixel electrode is applied; and the auxiliary electrode includes a portion overlapping at least one aperture or recessed portion of the pixel electrode, and is made of a same film as the semiconductor layer of the switching element.

[0014] In a preferred embodiment, the auxiliary electrode further includes a portion located near an outer periphery of the pixel electrode.

[0015] In a preferred embodiment, in each of the plurality of pixels, a plurality of liquid crystal domains each exhibiting an axisymmetric orientation are created when at least a predetermined voltage is applied across the liquid crystal layer.

[0016] In a preferred embodiment, a potential which is substantially the same as that for the counter electrode is applied to the auxiliary electrode.

[0017] In a preferred embodiment, the switching element is a thin film transistor whose channel region is a portion of the semiconductor layer.

[0018] In a preferred embodiment, the semiconductor layer and the auxiliary electrode are made of amorphous silicon or crystalline silicon.

[0019] In a preferred embodiment, the auxiliary electrode has a light transmittance of 60% or more.

[0020] In a preferred embodiment, the first substrate includes a storage capacitor line; and the auxiliary electrode is electrically connected to the storage capacitor line.

[0021] In a preferred embodiment, the first substrate includes a connection electrode for electrically connecting the auxiliary electrode and the storage capacitor line; and the

connection electrode is provided outside a displaying region which is defined by the plurality of pixels.

[0022] In a preferred embodiment, the first substrate includes a connection electrode for electrically connecting the auxiliary electrode and the storage capacitor line; the connection electrode is provided in each of the plurality of pixels; and the auxiliary electrode partially overlaps the storage capacitor line.

[0023] In a preferred embodiment, the connection electrode is disposed so that the entire connection electrode overlaps the storage capacitor line.

[0024] In a preferred embodiment, the first substrate includes a signal line; and the connection electrode is made of a same film as the signal line.

Effects of the Invention

[0025] A liquid crystal display device according to the present invention has an auxiliary electrode which includes a portion overlapping an aperture or recessed portion of a pixel electrode. By applying a different potential from that for the pixel electrode to the auxiliary electrode, the intensity of an orientation restriction force due to an oblique electric field which is generated in the aperture or recessed portion can be controlled. For example, an oblique electric field whose equipotential lines dip more steeply in the aperture or recessed portion can be generated, whereby a strong orientation restriction force can be obtained. As a result, it is possible to stably perform orientation control with an oblique electric field. Since the auxiliary electrode is made of the same film as the semiconductor layer of the switching element, it is possible to suppress decrease in light transmittance without much increase in the number of production steps.

BRIEF DESCRIPTION OF DRAWINGS

[0026] [FIG. 1] An upper plan view schematically showing a liquid crystal display device **100** according to a preferred embodiment of the present invention.

[0027] [FIG. 2] A cross-sectional view schematically showing a liquid crystal display device **100** according to a preferred embodiment of the present invention, showing a cross section along line 2A-2A' in FIG. 1.

[0028] [FIG. 3] A cross-sectional view schematically showing the liquid crystal display device **100** according to a preferred embodiment of the present invention, showing a cross section along line 3A-3A' in FIG. 1.

[0029] [FIG. 4](a) to (c) are diagrams schematically showing orientations of liquid crystal molecules, where: (a) shows an orientation in the absence of an applied voltage; (b) shows an orientation immediately after voltage application; and (c) shows an orientation when a sufficient time has elapsed since voltage application.

[0030] [FIG. 5] A diagram showing, by using equipotential lines, an electric field which is created when a voltage is applied across a liquid crystal layer, illustrating a case where no auxiliary electrode is provided.

[0031] [FIG. 6] A diagram showing, by using equipotential lines, an electric field which is created when a voltage is applied across a liquid crystal layer, illustrating a case where substantially the same potential as that for a counter electrode is applied to an auxiliary electrode.

[0032] [FIG. 7] A cross-sectional view schematically showing a liquid crystal display device **100'** according to a preferred embodiment of the present invention.

[0033] [FIG. 8] A cross-sectional view schematically showing the liquid crystal display device **100'** according to a preferred embodiment of the present invention.

[0034] [FIG. 9] An upper plan view schematically showing a liquid crystal display device **100** according to a preferred embodiment of the present invention.

[0035] [FIG. 10] An upper plan view schematically showing a liquid crystal display device **200** according to a preferred embodiment of the present invention.

[0036] [FIG. 11] A cross-sectional view schematically showing the liquid crystal display device **200** according to a preferred embodiment of the present invention, showing a cross section along line 11A-11A' in FIG. 10.

[0037] [FIG. 12] A cross-sectional view schematically showing the liquid crystal display device **200** according to a preferred embodiment of the present invention, showing a cross section along line 12A-12A' in FIG. 10.

[0038] [FIG. 13] A diagram showing a manner of electrical connection between auxiliary electrodes and storage capacitor lines in the liquid crystal display device **200**.

[0039] [FIG. 14](a) to (c) are step-by-step cross-sectional views schematically showing steps of forming a connection electrode in the liquid crystal display device **200**.

[0040] [FIG. 15] A cross-sectional view schematically showing a liquid crystal display device **200'** according to a preferred embodiment of the present invention.

[0041] [FIG. 16] A cross-sectional view schematically showing the liquid crystal display device **200'** according to a preferred embodiment of the present invention.

[0042] [FIG. 17](a) and (b) are cross-sectional views showing exemplary constructions for establishing electrical connection between an auxiliary electrode and a storage capacitor line within a pixel.

[0043] [FIG. 18](a) is an upper plan view showing an exemplary construction for establishing electrical connection between an auxiliary electrode and a storage capacitor line within a pixel; and (b) is a cross-sectional view taken along line 18B-18B' in (a).

[0044] [FIG. 19](a) is an upper plan view showing an exemplary construction for establishing electrical connection between an auxiliary electrode and a storage capacitor line within a pixel; and (b) is a cross-sectional view taken along line 19B-19B' in (a).

[0045] [FIG. 20](a) is an upper plan view showing an exemplary construction for establishing electrical connection between an auxiliary electrode and a storage capacitor line within a pixel; and (b) is a cross-sectional view taken along line 20B-20B' in (a).

[0046] [FIG. 21] An upper plan view schematically showing a liquid crystal display device **300** according to a preferred embodiment of the present invention.

[0047] [FIG. 22] A cross-sectional view schematically showing the liquid crystal display device **300** according to a preferred embodiment of the present invention, showing a cross section along line 22A-22A' in FIG. 21.

[0048] [FIG. 23] An upper plan view schematically showing a liquid crystal display device **400** according to a preferred embodiment of the present invention.

[0049] [FIG. 24] A cross-sectional view schematically showing the liquid crystal display device **400** according to a

preferred embodiment of the present invention, showing a cross section along line 24A-24A' in FIG. 23.

DESCRIPTION OF REFERENCE NUMERALS

[0050] 1, 1' thin film transistor (switching element)
 [0051] 2 pixel electrode
 [0052] 2a recessed portion
 [0053] 2T transparent electrode
 [0054] 2R reflection electrode
 [0055] 3 counter electrode
 [0056] 4 auxiliary electrode
 [0057] 4a portion of auxiliary electrode (portion overlapping recessed portion of pixel electrode)
 [0058] 4b portion of auxiliary electrode (portion located near outer periphery of pixel electrode)
 [0059] 4c portion of auxiliary electrode (portion overlapping electrically-conductive film of pixel electrode)
 [0060] 4d portion of auxiliary electrode (portion connected to auxiliary electrode of adjoining pixel)
 [0061] 5 connection electrode
 [0062] 6 protrusion
 [0063] 10, 30 transparent substrate
 [0064] 11 basecoat film
 [0065] 12 semiconductor layer
 [0066] 13 gate insulating film
 [0067] 14 gate electrode
 [0068] 15 scanning line
 [0069] 16 storage capacitor line
 [0070] 17 first interlayer insulating film
 [0071] 18 source electrode
 [0072] 19 drain electrode
 [0073] 20 signal line
 [0074] 21 second interlayer insulating film
 [0075] 22, 33 vertical alignment film
 [0076] 23, 34 polarizer
 [0077] 31 color filter
 [0078] 32 light shielding layer (black matrix)
 [0079] 50 liquid crystal layer
 [0080] 51 liquid crystal molecules
 [0081] 60 active matrix substrate
 [0082] 70 counter substrate (color filter substrate)
 [0083] 100, 100', 200, 200' liquid crystal display device
 [0084] 300, 400 liquid crystal display device

BEST MODE FOR CARRYING OUT THE INVENTION

[0085] Hereinafter, with reference to the drawings, embodiments of the present invention will be described. Note that the present invention is not limited to the following embodiments.

Embodiment 1

[0086] With reference to FIG. 1 to FIG. 3, the structure of a liquid crystal display device 100 according to the present embodiment will be described. FIG. 1 is an upper plan view schematically showing a region corresponding to one pixel of the liquid crystal display device 100. FIG. 2 and FIG. 3 are cross-sectional views along lines 2A-2A' and 3A-3A' in FIG. 1, respectively.

[0087] The liquid crystal display device 100 includes an active matrix substrate 60, a counter substrate (color filter

substrate) 70 provided so as to oppose the active matrix substrate 60, and a vertical-alignment type liquid crystal layer 50 provided therebetween.

[0088] Each of the plurality of pixels of the liquid crystal display device 100 includes a thin film transistor (TFT) 1 provided on the active matrix substrate 60, a pixel electrode 2 electrically connected to the thin film transistor 1, a counter electrode 3 opposing the pixel electrode 2, and a liquid crystal layer 50 interposed between the pixel electrode 2 and the counter electrode 3.

[0089] Hereinafter, the more specific structure of the active matrix substrate 60 and the counter substrate 70 will be described.

[0090] The active matrix substrate 60 includes a transparent substrate (e.g., a glass substrate or a plastic substrate) 10 supporting its component elements. A basecoat film 11 is formed on a surface of the transparent substrate 10 closer to the liquid crystal layer 50, and a semiconductor layer 12 of continuous grain silicon (CGS) is formed on the basecoat film 11. A portion of the semiconductor layer 12 functions as a channel region of the thin film transistor 1, and other portions function as a source region and a drain region.

[0091] A gate insulating film 13 is formed so as to cover the semiconductor layer 12. A gate electrode 14, a scanning line 15, and a storage capacitor line 16 are formed on the gate insulating film 13, and a first interlayer insulating film 17 is formed so as to cover them.

[0092] On the first interlayer insulating film 17, a source electrode 18, a drain electrode 19, and a signal line 20 are formed. In contact holes which are formed in the gate insulating film 13 and the first interlayer insulating film 17, the source electrode 18 and the drain electrode 19 are connected to the semiconductor layer 12.

[0093] A second interlayer insulating film 21 is formed so as to cover the source electrode 18, the drain electrode 19, and the signal line 20, and a pixel electrode 2 is provided on the second interlayer insulating film 21. The second interlayer insulating film 21 is an organic insulating film made of an acrylic type photosensitive resin or the like, for example. The pixel electrode 2 is made of a transparent electrically conductive material (e.g. ITO). On a surface of the transparent substrate 10 opposite from the liquid crystal layer 50, a polarizer 23 is provided.

[0094] On a surface of the transparent substrate 30 closer to the liquid crystal layer 50, the counter substrate 70 includes a color filter 31, a light shielding layer (also referred to as a black matrix) 32, and the counter electrode in this order. The counter electrode 3 is made of a transparent electrically conductive material (e.g. ITO). On a surface of the transparent substrate 30 opposite from the liquid crystal layer 50, a polarizer 34 is provided.

[0095] The liquid crystal layer 50 interposed between the active matrix substrate 60 and the counter substrate 70 is made of a nematic liquid crystal material having a negative dielectric anisotropy, and contains a chiral agent as necessary. On surfaces of the active matrix substrate 60 and the counter substrate 70 that are in contact with the liquid crystal layer 50, vertical alignment films 22 and 33 are provided. The vertical alignment films 22 and 33 cause liquid crystal molecules 51 in the liquid crystal layer 50 to be aligned substantially perpendicular to their surfaces. The vertical alignment films 22 and 33 are made of polyimide resin, for example.

[0096] A pixel electrode 2 of the liquid crystal display device 100 includes a plurality of recessed portions 2a formed

at predetermined positions in the pixel. In the present embodiment, four recessed portions **2a** are provided in the pixel electrode **2**, and the pixel is divided into three regions by the recessed portions **2a**. The individual regions divided by the recessed portions **2a** are also referred to as subpixels.

[0097] When a predetermined potential difference is given between the pixel electrode **2** and the counter electrode **3** (i.e., a predetermined voltage is applied across the liquid crystal layer **50**), an oblique electric field (a potential gradient which is tilted with respect to the substrate surface) is generated near the outer periphery of the pixel electrode **2** and at the recessed portions **2a**, and this oblique electric field defines the directions in which the liquid crystal molecules **51** fall. Due to the action of the oblique electric field, a plurality of (herein three) liquid crystal domains are created each exhibiting an axisymmetric orientation. In each liquid crystal domain, the liquid crystal molecules **51** are orientated in almost all azimuthal directions, and thus, when a voltage is applied across the liquid crystal layer **50**, a plurality of regions are formed in which the liquid crystal molecules **51** are tilted in respectively different azimuthal directions in the liquid crystal display device **100**.

[0098] With reference to FIG. 4, the mechanism by which axisymmetric orientations are created will be described more specifically. FIGS. 4(a) to (c) are diagrams schematically showing orientations of the liquid crystal molecules **51**, where: FIG. 4(a) shows a state in the absence of an applied voltage; FIG. 4(b) shows a state immediately after voltage application; and FIG. 4(c) shows a state when a sufficient time has elapsed since voltage application.

[0099] As shown in FIG. 4(a), in the absence of an applied voltage, the liquid crystal molecules **51** are orientated substantially perpendicularly to the substrate surface due to the orientation restriction forces of the vertical alignment films **22** and **33**.

[0100] Under an applied voltage, the liquid crystal molecules **51** having a negative dielectric anisotropy are tilted so that their molecular major axes are perpendicular to the electric lines of force (i.e., parallel to the equipotential lines), and therefore, the directions in which the liquid crystal molecules **51** fall are defined by an oblique electric field which is generated near the outer periphery of and at the recessed portions **2a** of the pixel electrode **2**. Therefore, as shown in FIG. 4(b), the liquid crystal molecules **51** in the region where the oblique electric field is generated (i.e., the liquid crystal molecules **51** which directly receive the orientation restriction force due to the oblique electric field) are the first to be tilted.

[0101] Thereafter, with lapse of time, the other liquid crystal molecules **51** will be orientated in continuous manners (so as to match the orientations of the liquid crystal molecules **51** that were the first to be tilted), whereby liquid crystal domains as shown in FIG. 4(c) are formed. Since the liquid crystal molecules **51** are orientated in almost all azimuthal directions (all azimuthal directions within the substrate plane) in each liquid crystal domain, the liquid crystal display device **100** has excellent viewing angle characteristics.

[0102] Herein, "axisymmetric orientation" is synonymous with "radially-inclined orientation" in Patent Document 1. Around the center axis of axisymmetric orientation, the liquid crystal molecules **51** are continuously oriented without forming disclination lines, and the major axes of the liquid crystal molecules **51** are oriented in a radial, tangential, or spiral manner. In either case, the major axes of the liquid crystal

molecules **51** have components which are radially-inclined from the center of orientation (components which are parallel to the oblique electric field).

[0103] Note that it is not necessary that a plurality of recessed portions **2a** be provided as is exemplified herein; it suffices if at least one recessed portion **2a** is provided. For example, in the case where a pixel is divided into two regions, liquid crystal domains with axisymmetric orientations can be created by providing only one oblong recessed portion **2a**. Moreover, an aperture may be provided instead of a recessed portion **2a** (or in addition to a recessed portion **2a**). In the case where an aperture is provided in the pixel electrode **2**, as in the case of a recessed portion **2a**, an oblique electric field is formed in any aperture surrounded by the electrically-conductive film of the pixel electrode **2**, thus defining the directions in which the liquid crystal molecules **51** are tilted due to an electric field.

[0104] Next, the construction of the liquid crystal display device **100** according to the present embodiment will be described in more detail.

[0105] As shown in FIG. 1 to FIG. 3, the active matrix substrate **60** of the liquid crystal display device **100** includes auxiliary electrodes **4** to which a different potential from that for the pixel electrode **2** is applied. As shown in FIG. 3, an auxiliary electrode **4** in the present embodiment is connected to the storage capacitor line **16** through a contact hole which is formed in the gate insulating film **13**, whereby a potential (e.g., the same potential as that for the counter electrode **3** as will be described later) which is different from that for the pixel electrode **2** can be applied to the auxiliary electrode **4**.

[0106] As shown in FIG. 1, an auxiliary electrode **4** includes portions **4a** which overlap the recessed portions **2a** of the pixel electrode **2**, and a portion **4b** which is located near the outer periphery of the pixel electrode **2**. Moreover, the auxiliary electrode **4** is made of the same film as the semiconductor layer **12** of the thin film transistor **1**. In other words, the auxiliary electrode **4** is formed concurrently with the semiconductor layer **12** by patterning the semiconductor film for forming the semiconductor layer **12** of the thin film transistor **1**.

[0107] The liquid crystal display device **100** of the present embodiment includes auxiliary electrodes **4** as described above. By applying a different potential from that for the pixel electrode **2** to each auxiliary electrode **4**, it becomes possible to control the intensity of the orientation restriction force due to an oblique electric field. Hereinafter, this point will be described in more detail.

[0108] FIG. 5 and FIG. 6 are diagrams showing, by using equipotential lines EQ, electric fields which are created when a voltage is applied across the liquid crystal layer **50**. FIG. 5 illustrates a case where auxiliary electrodes **4** are not provided, whereas FIG. 6 illustrates a case where substantially the same potential as that for the counter electrode **3** is applied to an auxiliary electrode **4**.

[0109] When a voltage is applied across the liquid crystal layer **50**, as shown in FIG. 5 and FIG. 6, a potential gradient which is represented by equipotential lines (which are orthogonal to electric lines of force) EQ is created. The equipotential lines EQ run parallel to the substrate surface in the liquid crystal layer **50** which is interposed between the electrically-conductive film of the pixel electrode **2** (i.e., the portion excluding the recessed portions **2a**) and the counter electrode **3**, and dip in any region corresponding to the neighborhood of the outer periphery of and the recessed por-

tions **2a** of the pixel electrode **2**. Therefore, in the liquid crystal layer **50** in any region corresponding to the neighborhood of the outer periphery of and the recessed portions **2a** of the pixel electrode **2**, an oblique electric field which is represented by tilted equipotential lines EQ is created.

[0110] In the case where auxiliary electrodes **4** are not provided, as shown in FIG. 5, equipotential lines EQ are continuous between adjoining subpixels, so that the equipotential lines EQ present continuous rises and falls. In other words, a relatively gentle potential gradient is created.

[0111] On the other hand, in the case where an auxiliary electrode **4** is provided and substantially the same potential as that for the counter electrode **3** is applied to the auxiliary electrode **4**, as shown in FIG. 6, equipotential lines EQ are not continuous between adjoining subpixels, but the equipotential lines EQ abruptly dip above the recessed portion **2a**. Therefore, a steep potential gradient is created in the recessed portion **2a**, thus resulting in a stronger oblique electric field than that shown in FIG. 5. Therefore, a strong orientation restriction force can be obtained.

[0112] As described above, since the liquid crystal display device **100** in the present embodiment includes the auxiliary electrodes **4**, orientation control can be stably performed with an oblique electric field. Moreover, since the auxiliary electrodes **4** are made of the same film as the semiconductor layer **12** of the thin film transistor **1**, a high light transmittance can be provided. For example, an auxiliary electrode **4** which is made of continuous grain silicon (CGS) can realize a light transmittance of about 80% with a thickness of about 50 nm. Furthermore, since the auxiliary electrodes **4** are made of the same film as the semiconductor layer **12** of the thin film transistor **1**, hardly any new steps for providing the auxiliary electrodes **4** are needed. Therefore, it is possible to suppress decrease in light transmittance without much increase in the number of production steps.

[0113] The present embodiment illustrates as a switching element the thin film transistor **1** including the semiconductor layer **12** which is made of continuous grain silicon; however, the switching element is not limited thereto. The semiconductor layer **12** may be made of crystalline silicon such as continuous grain silicon or polycrystalline silicon, or made of amorphous silicon.

[0114] FIG. 7 and FIG. 8 show a liquid crystal display device **100'** having thin film transistors **1'** including a semiconductor layer **12** which is made of amorphous silicon. The liquid crystal display device **100** shown in FIG. 2 and FIG. 3 has the top-gate type thin film transistors **1** including the semiconductor layer **12** made of continuous grain silicon, whereas the liquid crystal display device **100'** shown in FIG. 7 and FIG. 8 has the bottom-gate type thin film transistors **1'** including the semiconductor layer **12** made of amorphous silicon.

[0115] The liquid crystal display device **100'** also includes auxiliary electrodes **4** made of the same film as the semiconductor layer **12** of the thin film transistor **1'** (i.e., made of amorphous silicon). Therefore, effects similar to those of the liquid crystal display device **100** are obtained. The thickness of the auxiliary electrode **4** made of amorphous silicon is about 35 nm, for example.

[0116] Note that, in each of the liquid crystal display devices **100** and **100'**, the thickness of the auxiliary electrodes **4** is not limited to the exemplified value. However, in order to sufficiently suppress decrease in the light transmittance of a pixel, the auxiliary electrodes **4** are preferably formed with a

thickness such that it has a light transmittance of 60% or more, and more preferably 80% or more. An auxiliary electrode **4** made of crystalline silicon can realize a light transmittance of 80% or more with a thickness of 60 nm or less, and a light transmittance of 60% or more with a thickness of 114 nm or less. Note that the semiconductor layer **12** of the switching element and the auxiliary electrodes **4** do not need to have the same thickness, and they may have respectively different thicknesses. However, from the standpoint of suppressing increase in the number of steps, it is preferable that they have almost the same thickness.

[0117] FIG. 1 to FIG. 3, FIG. 7, and FIG. 8 illustrate constructions where the electrically-conductive film of a pixel electrode **2** and an auxiliary electrode **4** do not overlap each other. However, as shown in FIG. 9, the auxiliary electrode **4** may include portions **4c** which overlap the electrically-conductive film of the pixel electrode **2**, and the region where each portion **4c** overlaps the pixel electrode **2** may be used as a portion of a storage capacitor.

Embodiment 2

[0118] With reference to FIG. 10 to FIG. 12, the structure of a liquid crystal display device **200** according to the present embodiment will be described. FIG. 10 is an upper plan view schematically showing a region corresponding to one pixel of the liquid crystal display device **200**. FIG. 11 and FIG. 12 are cross-sectional views taken along line **11A-11A'** and line **12A-12A'** in FIG. 10, respectively.

[0119] As shown in FIG. 10 to FIG. 12, the liquid crystal display device **200** includes auxiliary electrodes **4** which are made of the same film as the semiconductor layer **12** of the thin film transistors **1**, and therefore is able to stably perform orientation control with an oblique electric field, and suppress decrease in light transmittance while suppressing increase in the number of steps.

[0120] However, the liquid crystal display device **200** of the present embodiment differs from the liquid crystal display device **100** of Embodiment 1 in terms of the manner of electrical connection between an auxiliary electrode **4** and a storage capacitor line **16**. In the liquid crystal display device **100**, as is also shown in FIG. 3, an auxiliary electrode **4** is connected to a storage capacitor line **16** through a contact hole which is provided in the gate insulating film **13**, thus being electrically connected to the storage capacitor line **16** within each pixel.

[0121] On the other hand, in the liquid crystal display device **200**, as can also be seen from FIG. 12, the auxiliary electrode **4** is not connected to the storage capacitor line **16** within the pixel. The auxiliary electrode **4** in the present embodiment is electrically connected to the storage capacitor line **16** outside a displaying region which is defined by a plurality of pixels (also referred to as the peripheral region).

[0122] Specifically, as shown in FIG. 13, each auxiliary electrode **4** includes a portion **4d** which is connected to the auxiliary electrode **4** of an adjoining pixel, and a plurality of auxiliary electrodes **4** which are mutually connected via the portions **4d** are electrically connected to the storage capacitor line **16** via a connection electrode **5** which is provided outside the displaying region (peripheral region).

[0123] The connection electrode **5** in the present embodiment is made of the same film as the signal line **20**. The connection electrode **5** is formed as shown in FIGS. 14(a) to (c). FIGS. 14(a) to (c) are step-by-step cross-sectional views

showing steps of forming the connection electrode 5, corresponding to a cross section along 14A-14A' in FIG. 13.

[0124] FIG. 14(a) shows, in the steps of producing the active matrix substrate 60, a state where the basecoat film 11, the auxiliary electrodes 4, the gate insulating film 13, the storage capacitor lines 16, and the first interlayer insulating film 17 have been stacked on the transparent substrate 10.

[0125] After the first interlayer insulating film 17 is deposited, the gate insulating film 13 and the first interlayer insulating film 17 above the portions of the semiconductor layer 12 to become source regions and gate regions are removed, whereby contact holes are formed. At this time, as shown in FIG. 14(b), contact holes are also formed outside the displaying region. Specifically, outside the displaying region, two contact holes are formed by removing the gate insulating film 13 and the first interlayer insulating film 17 above an auxiliary electrode 4 and the first interlayer insulating film 17 above a storage capacitor line 16.

[0126] Thereafter, by depositing an electrically-conductive film on the first interlayer insulating film 17 and then patterning the electrically-conductive film, the source electrodes 18, the drain electrodes 19, and the signal lines 20 are formed. At this time, as shown in FIG. 14(c), the connection electrode 5 is also formed.

[0127] As shown in FIG. 3, in the case where the auxiliary electrode 4 and the storage capacitor line 16 are connected within the pixel through a contact hole which is formed in the gate insulating film 13, a step of forming the contact hole in the gate insulating film 13 is required. On the other hand, in the case where the connection electrode 5 is formed in the above-described manner, it is possible to electrically connect the auxiliary electrodes 4 and the storage capacitor lines 16 without adding any steps. Moreover, since the connection electrode 5 is provided outside the displaying region, the connection electrode 5 will not deteriorate the light transmittance of the pixels.

[0128] Also in the present embodiment, the thin film transistor 1 including the semiconductor layer 12 which is made of continuous grain silicon is illustrated a switching element; however, the switching element is not limited thereto. The semiconductor layer 12 may be made of crystalline silicon such as continuous grain silicon or polycrystalline silicon, or made of amorphous silicon.

[0129] FIG. 15 and FIG. 16 show a liquid crystal display device 200' having a thin film transistor 1' including a semiconductor layer 12 which is made of amorphous silicon. The liquid crystal display device 200 shown in FIG. 11 and FIG. 12 has the top-gate type thin film transistors 1 including the semiconductor layer 12 made of continuous grain silicon, whereas the liquid crystal display device 200' shown in FIG. 15 and FIG. 16 has the bottom-gate type thin film transistors 1' including the semiconductor layer 12 made of amorphous silicon.

[0130] The liquid crystal display device 200' also includes auxiliary electrodes 4 which are made of the same film as the semiconductor layer 12 of the thin film transistors 1' (i.e., made of amorphous silicon). Therefore, it is possible to stably perform orientation control with an oblique electric field, and also suppress decrease in light transmittance.

[0131] In the liquid crystal display device 200', too, as can also be seen from FIG. 16, the auxiliary electrode 4 is not connected to a storage capacitor line 16 within the pixel, but is electrically connected to the storage capacitor line 16 outside the displaying region (peripheral region). In the periph-

eral region, the auxiliary electrode 4 is connected to a storage capacitor line 16 through contact holes which are provided in the gate insulating film 13, for example. In this case, a step of forming contact holes in the gate insulating film 13 is required. However, under specifications where a portion of the gate insulating film 13 is meant to be removed because of a certain requirement anyway, the auxiliary electrode 4 and the storage capacitor line 16 can be electrically connected without adding any steps, by utilizing the step of patterning the gate insulating film 13 as an opportunity to form the contact holes.

[0132] Note that, in the liquid crystal display device 100 of Embodiment 1, as shown in FIG. 17(a), the auxiliary electrode 4 and the storage capacitor line 16 are directly connected through a contact hole which is provided in the gate insulating film 13 within the pixel. FIG. 17(a) is a cross-sectional view showing the neighborhood of the storage capacitor line 16 in FIG. 3, corresponding to a cross section along line 17A-17A' in FIG. 1. Instead of employing this construction, as shown in FIG. 17(b), a connection electrode 5 which is made of the same film as the signal line 20 may be provided within the pixel, and the auxiliary electrode 4 and the storage capacitor line 16 may be electrically connected with the connection electrode 5. By adopting such a construction, without adding any steps, the auxiliary electrode 4 and the storage capacitor line 16 can be electrically connected.

[0133] However, in the case where a connection electrode 5 is provided within the pixel, the light transmittance of the pixel may be lowered, depending on the relative positioning of the auxiliary electrode 4 and the storage capacitor line 16. For example, as shown in FIGS. 18(a) and (b), if the connection electrode 5 is provided in the case where the auxiliary electrode 4 and the storage capacitor line 16 do not overlap, there will be a region that is shaded by the connection electrode 5, and thus the light transmittance of the pixel will be deteriorated.

[0134] On the other hand, in the case where the auxiliary electrode 4 and the storage capacitor line 16 partially overlap, as shown in FIGS. 19(a) and (b), the width of the shaded region can be reduced, thus making it possible to suppress decrease in light transmittance. Moreover, in the case where the auxiliary electrode 4 and the storage capacitor line 16 partially overlap, as shown in FIGS. 20(a) and (b), a contact hole may be formed in the storage capacitor line 16, and the connection electrode 5 may be disposed so that its entirety overlaps the storage capacitor line 16; thus, there will be no shaded region, and lowering of the light transmittance can be prevented.

Embodiment 3

[0135] In Embodiments 1 and 2, the present invention has been described by taking a transmission type liquid crystal display device which presents display in the transmission mode as an example. However, the present invention is also suitably used for a transmission/reflection combination type liquid crystal display device which is capable of presenting display in both of the transmission mode and the reflection mode.

[0136] FIG. 21 and FIG. 22 show a liquid crystal display device 300 according to the present embodiment. FIG. 21 is an upper plan view schematically showing a region corresponding to one pixel of the liquid crystal display device 300. FIG. 22 is a cross-sectional view along line 22A-22A' in FIG. 21.

[0137] Each pixel of the liquid crystal display device 300 includes a transmission region T which presents display in the transmission mode and a reflection region R which presents display in the reflection mode. A pixel electrode 2 of the liquid crystal display device 300 includes a transparent electrode 2T which is made of an electrically conductive material having a high light transmittance (e.g. ITO) and a reflection electrode 2R which is made of an electrically conductive material having a high light reflectance (e.g. aluminum). The transparent electrode 2T is formed across both of the two subpixels, whereas the reflection electrode 2R is selectively formed in only one of the subpixels, so that the region where the reflection electrode 2R is formed functions as the reflection region R.

[0138] Moreover, a transparent dielectric layer 35 is provided in the region of the counter substrate 70 corresponding to the reflection region R, so that the thickness of the liquid crystal layer 50 in the reflection region R is smaller than the thickness of the liquid crystal layer 50 in the transmission region T. The light which is utilized in the reflection mode travels through the liquid crystal layer 50 twice, whereas the light which is utilized in the transmission mode travels through the liquid crystal layer 50 only once. However, as mentioned above, the liquid crystal layer 50 in the reflection region R is made thinner than the liquid crystal layer 50 in the transmission region T, so that the optical path difference between the reflection region R and the transmission region T can be reduced. As a result, display can be suitably presented in both of the reflection region R and the transmission region T.

[0139] The liquid crystal display device 300 also includes auxiliary electrodes 4 which are made of the same film as the semiconductor layer 12 of the thin film transistor 1. Therefore, it is possible to stably perform orientation control with an oblique electric field and also suppress decrease in light transmittance without much increase in the number of production steps.

[0140] Note that Embodiments 1, 2, and 3 described above illustrate constructions where orientation restriction structures (recessed portions 2a of the pixel electrode 2) are provided only on the active matrix substrate 60. However, as necessary, orientation restriction structures may be provided also on the counter substrate 70.

[0141] FIG. 23 and FIG. 24 show a liquid crystal display device 400 which has orientation restriction structures also on the counter substrate 70. As shown in FIG. 23 and FIG. 24, the liquid crystal display device 400 differs from the liquid crystal display device 100 of Embodiment 1 in that protrusions 6 are provided on the counter substrate 70.

[0142] Each protrusion 6 projecting toward the liquid crystal layer 50 has a slanted side face, and an orientation restriction force is exhibited due to an anchoring effect of the vertical alignment film 33 on this side face. The orientation restriction force due to the protrusion 6 acts to orient the liquid crystal molecules 51 in the same directions as the orientation restriction forces due to the recessed portions 2a of the pixel electrode 2, so that the axisymmetric orientation of the liquid crystal molecules 51 in the subpixel is further stabilized. Moreover, since the axisymmetric orientation is created around the protrusion 6 which is provided in the substantial center of a subpixel (i.e., the protrusion 6 is provided in a region corresponding to the substantial center of a liquid crystal domain), the center of the axisymmetric orientation is fixed near the protrusion 6.

[0143] Thus, the axisymmetric orientation can be stabilized by: restricting the orientation directions, mainly, the liquid crystal molecules 51 around the subpixel with the orientation restriction structures provided on the one substrate (the recessed portions 2a or apertures of the pixel electrode 2), and restricting the orientations of the liquid crystal molecules 51 at the central portion of the subpixel with the orientation restriction structure (protrusion 6) provided on the other substrate. This makes it possible to shorten the response time in gray-scale displaying, and the time in which a disturbance in orientation resulting from pressing the panel surface is eliminated.

[0144] Note that the orientation restriction structures to be provided on the counter substrate 70 are not limited to the protrusion 6 as illustrated. For example, apertures located at the subpixel centers may be provided on the counter electrode 3.

INDUSTRIAL APPLICABILITY

[0145] According to the present invention, in a vertical alignment mode liquid crystal display device, it is possible to stably perform orientation control with an oblique electric field, and also suppress decrease in light transmittance without much increase in the number of production steps. The present invention is suitably used for a transmission type or transmission/reflection combination type liquid crystal display device which is active-matrix driven.

1. A liquid crystal display device comprising a first substrate, a second substrate provided so as to oppose the first substrate, and a vertical-alignment type liquid crystal layer provided between the first substrate and the second substrate, the liquid crystal display device having a plurality of pixels each including: a switching element which is provided on the first substrate and at least includes a semiconductor layer; a pixel electrode electrically connected to the switching element; a counter electrode opposing the pixel electrode; and the liquid crystal layer interposed between the pixel electrode and the counter electrode, the pixel electrode including at least one aperture or recessed portion formed at a predetermined position in the pixel, and in each of the pixels, when at least a predetermined voltage is applied across the liquid crystal layer, a plurality of regions being created where liquid crystal molecules tilt in respectively different azimuthal directions, wherein, the first substrate includes an auxiliary electrode to which a different potential from that for the pixel electrode is applied; and the auxiliary electrode includes a portion overlapping at least one aperture or recessed portion of the pixel electrode, and is made of a same film as the semiconductor layer of the switching element.
2. The liquid crystal display device of claim 1, wherein the auxiliary electrode further includes a portion located near an outer periphery of the pixel electrode.
3. The liquid crystal display device of claim 1, wherein, in each of the plurality of pixels, a plurality of liquid crystal domains each exhibiting an axisymmetric orientation are created when at least a predetermined voltage is applied across the liquid crystal layer.
4. The liquid crystal display device of claim 1, wherein a potential which is substantially the same as that for the counter electrode is applied to the auxiliary electrode.

5. The liquid crystal display device of claim 1, wherein the switching element is a thin film transistor whose channel region is a portion of the semiconductor layer.

6. The liquid crystal display device of claim 1, wherein the semiconductor layer and the auxiliary electrode are made of amorphous silicon or crystalline silicon.

7. The liquid crystal display device of claim 1, wherein the auxiliary electrode has a light transmittance of 60% or more.

8. The liquid crystal display device of claim 1, wherein, the first substrate includes a storage capacitor line; and the auxiliary electrode is electrically connected to the storage capacitor line.

9. The liquid crystal display device of claim 8, wherein, the first substrate includes a connection electrode for electrically connecting the auxiliary electrode and the storage capacitor line; and

the connection electrode is provided outside a displaying region which is defined by the plurality of pixels.

10. The liquid crystal display device of claim 8, wherein, the first substrate includes a connection electrode for electrically connecting the auxiliary electrode and the storage capacitor line;

the connection electrode is provided in each of the plurality of pixels; and

the auxiliary electrode partially overlaps the storage capacitor line.

11. The liquid crystal display device of claim 10, wherein the connection electrode is disposed so that the entire connection electrode overlaps the storage capacitor line.

12. The liquid crystal display device of claim 9, wherein, the first substrate includes a signal line; and

the connection electrode is made of a same film as the signal line.

* * * * *

专利名称(译)	液晶显示器		
公开(公告)号	US20100060813A1	公开(公告)日	2010-03-11
申请号	US12/519447	申请日	2007-11-30
[标]申请(专利权)人(译)	川岛YUKI 康敏田坂		
申请(专利权)人(译)	川岛YUKI 康敏田坂		
当前申请(专利权)人(译)	夏普株式会社		
[标]发明人	KAWASHIMA YUKI TASAKA YASUTOSHI		
发明人	KAWASHIMA, YUKI TASAKA, YASUTOSHI		
IPC分类号	G02F1/1343		
CPC分类号	G02F1/133707 G02F1/1393 G02F1/134309		
优先权	2006339795 2006-12-18 JP		
其他公开文献	US8068201		
外部链接	Espacenet USPTO		

摘要(译)

在垂直取向模式液晶显示装置中，稳定地进行具有倾斜电场的取向控制，并且在不增加生产步骤数量的情况下抑制了透光率的降低。根据本发明的液晶显示装置包括第一基板，设置成与第一基板相对的第二基板，以及设置在第一基板和第二基板之间的垂直取向型液晶层，并且具有多个每个像素包括：开关元件，其设置在第一基板上并且至少包括半导体层；像素电极，电连接到开关元件；与像素电极相对的对电极；液晶层夹在像素电极和对电极之间。像素电极包括形成在像素中的预定位置处的至少一个凹陷部分（或孔径），并且在多个像素中的每个像素中，当在液晶层上施加至少预定电压时，多个区域是在液晶分子分别在不同的方位角方向上倾斜的地方产生。第一基板包括辅助电极，与像素电极的电位不同的辅助电极施加到辅助电极。辅助电极包括与像素电极的凹陷部分（或孔径）重叠的部分，并且由与开关元件的半导体层相同的膜制成。

