



US 20060125986A1

(19) **United States**

(12) **Patent Application Publication**
Choo et al.

(10) **Pub. No.: US 2006/0125986 A1**
(43) **Pub. Date: Jun. 15, 2006**

(54) **ARRAY SUBSTRATE, METHOD OF MANUFACTURING THE SAME AND LIQUID CRYSTAL DISPLAY APPARATUS HAVING THE SAME**

Publication Classification

(51) **Int. Cl.**
G02F 1/1335 (2006.01)
(52) **U.S. Cl.** 349/114

(76) Inventors: **Dae-Ho Choo**, Yongin-si (KR);
Ho-Min Kang, Suwon-si (KR);
Jae-Hoon Hwang, Seoul (KR);
Jeong-Min Oh, Seoul (KR); **Jung-Woo Park**, Seoul (KR); **Min-Sung Kwon**,
Hwaseong-si (KR); **Dae-Seung Yun**,
Suwon-si (KR)

(57) **ABSTRACT**

An array substrate includes a transparent substrate, a switching device, an insulation layer, a pixel electrode, a reflective plate and an inner polarization layer. The transparent substrate has a reflective region and a transmissive region. The switching device is formed in the reflective region. The insulation layer is formed on the transparent substrate to cover the switching device. The insulation layer has a contact hole that exposes a portion of a drain electrode of the switching device. The pixel electrode is electrically connected to the drain electrode of the switching device through the contact hole. The reflective plate is electrically connected to the pixel electrode and is disposed at the reflective region. The inner polarization layer covers the reflective plate. Thus the white luminance and the contrast ratio of an LCD apparatus having the above array substrate are enhanced.

Correspondence Address:
F. CHAU & ASSOCIATES, LLC
130 WOODBURY ROAD
WOODBURY, NY 11797 (US)

(21) Appl. No.: **11/299,595**

(22) Filed: **Dec. 12, 2005**

(30) **Foreign Application Priority Data**

Dec. 13, 2004 (KR) 2004-104951
Feb. 4, 2005 (KR) 2005-10697
Feb. 5, 2005 (KR) 2005-10929

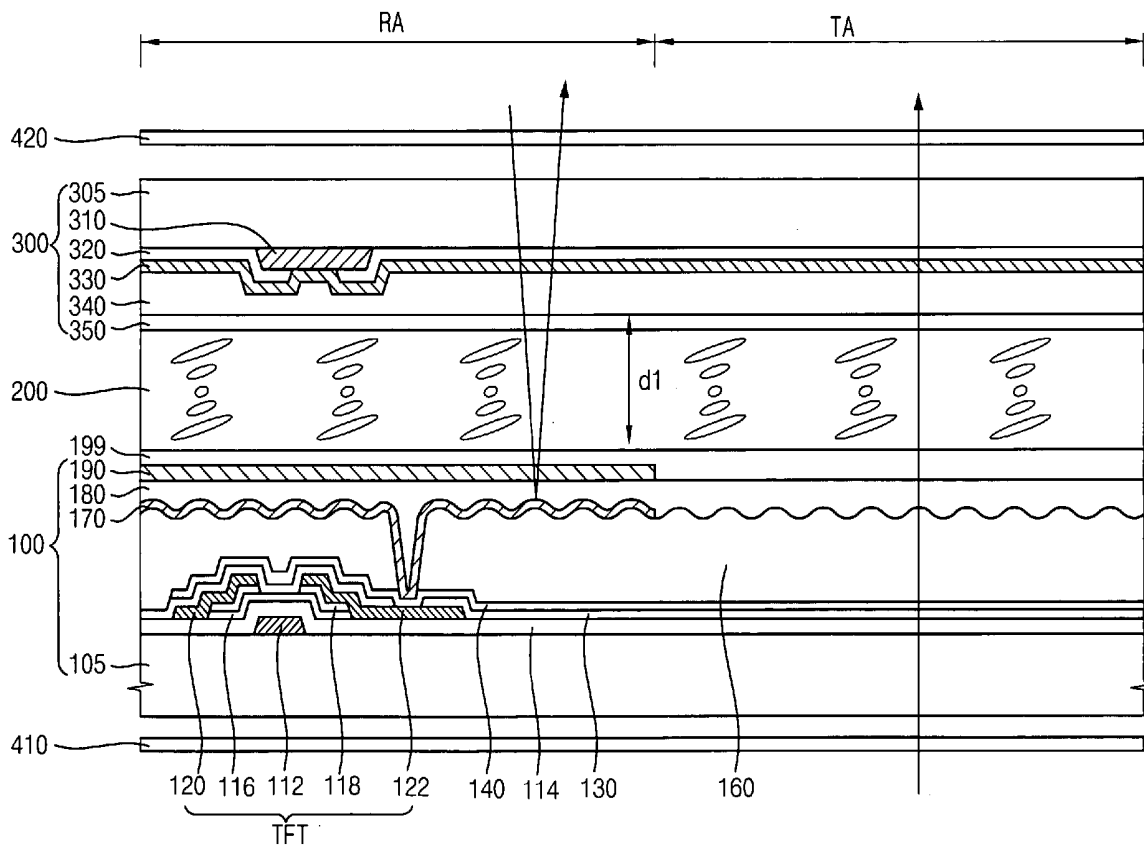

FIG. 1

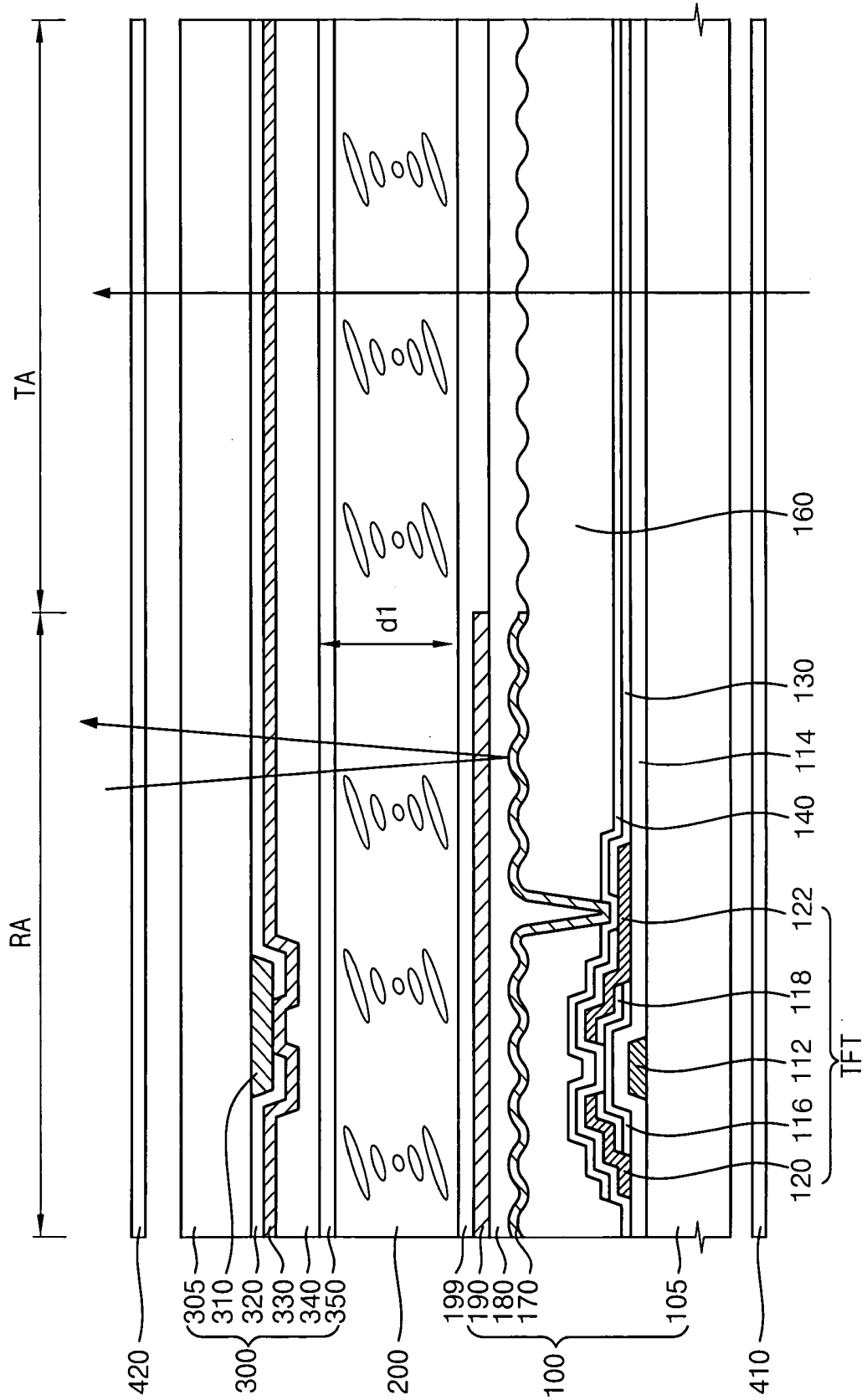

FIG. 2A

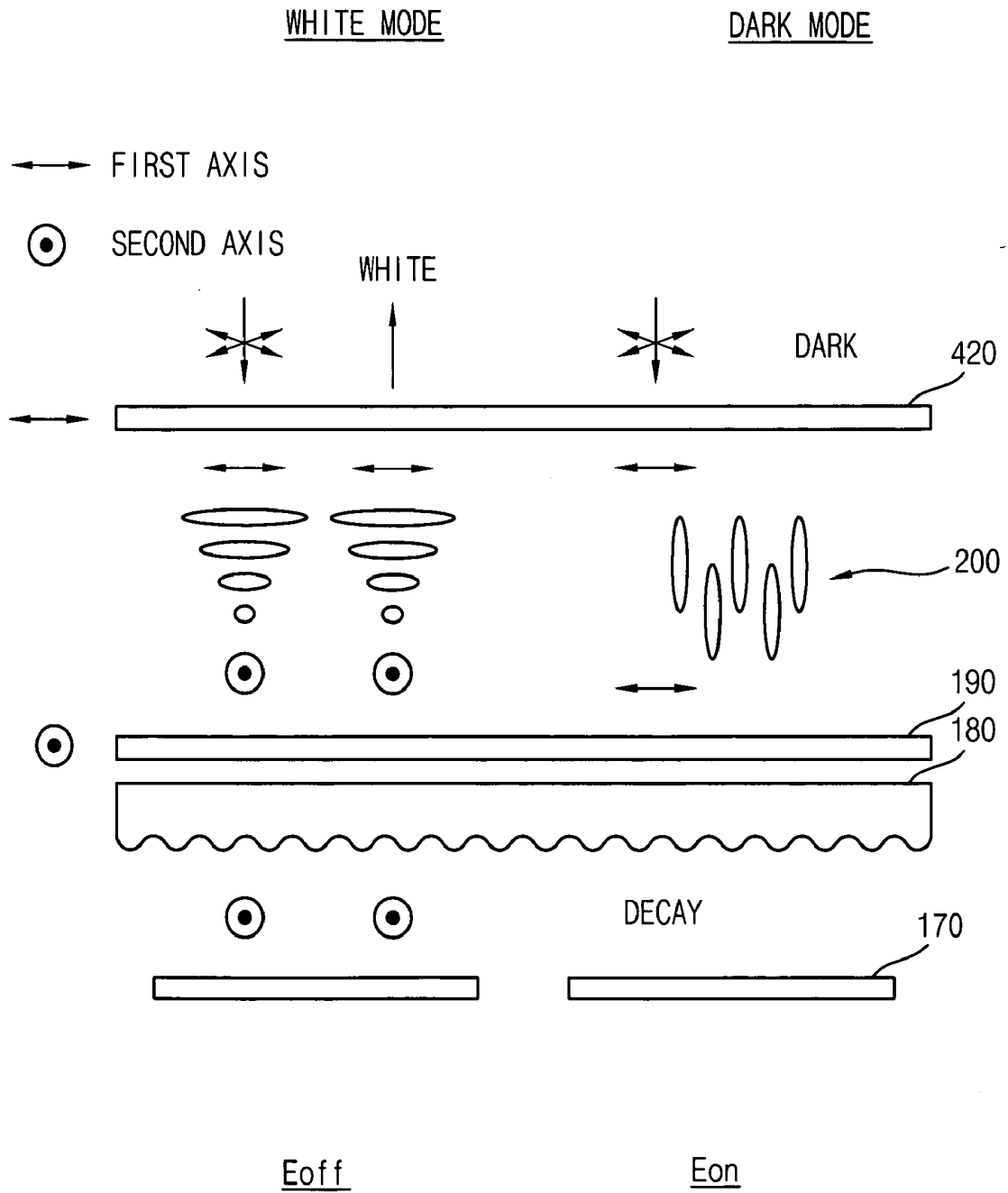

FIG. 2B

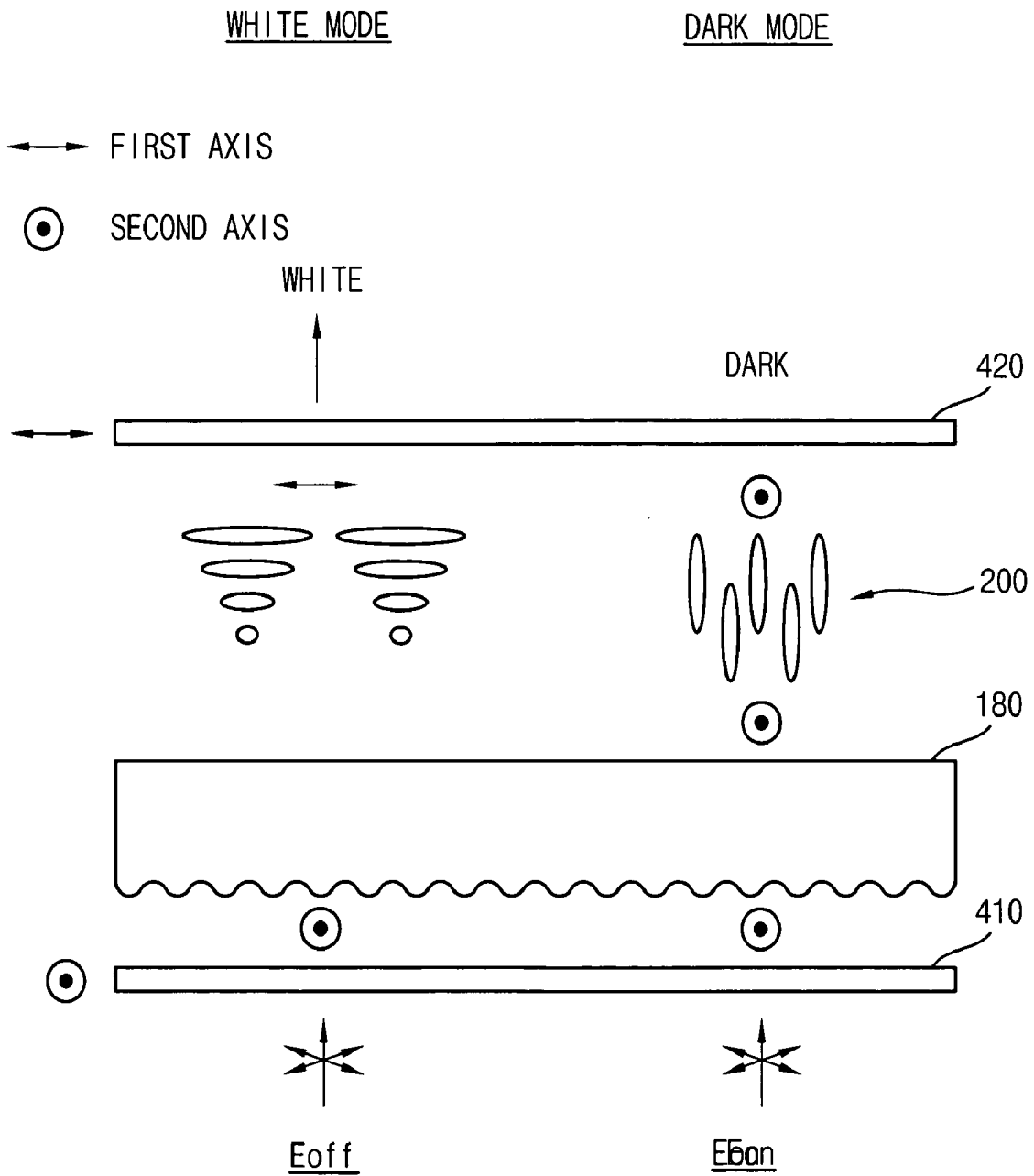

FIG. 3A

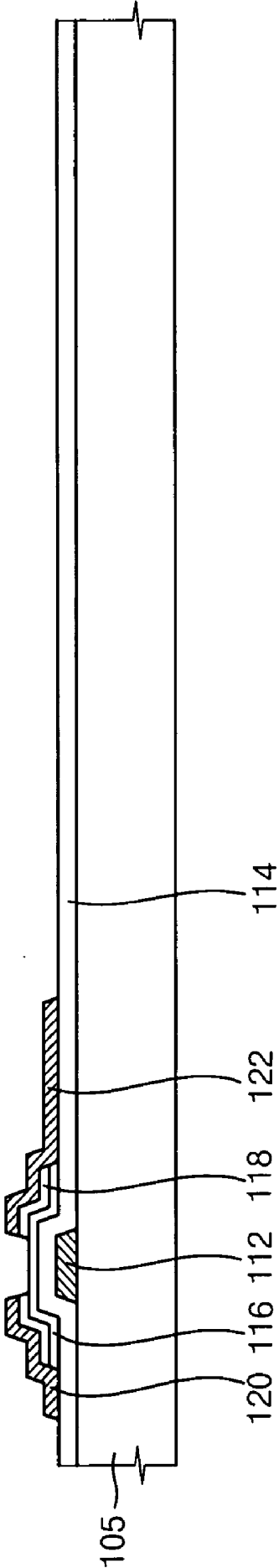

FIG. 3B

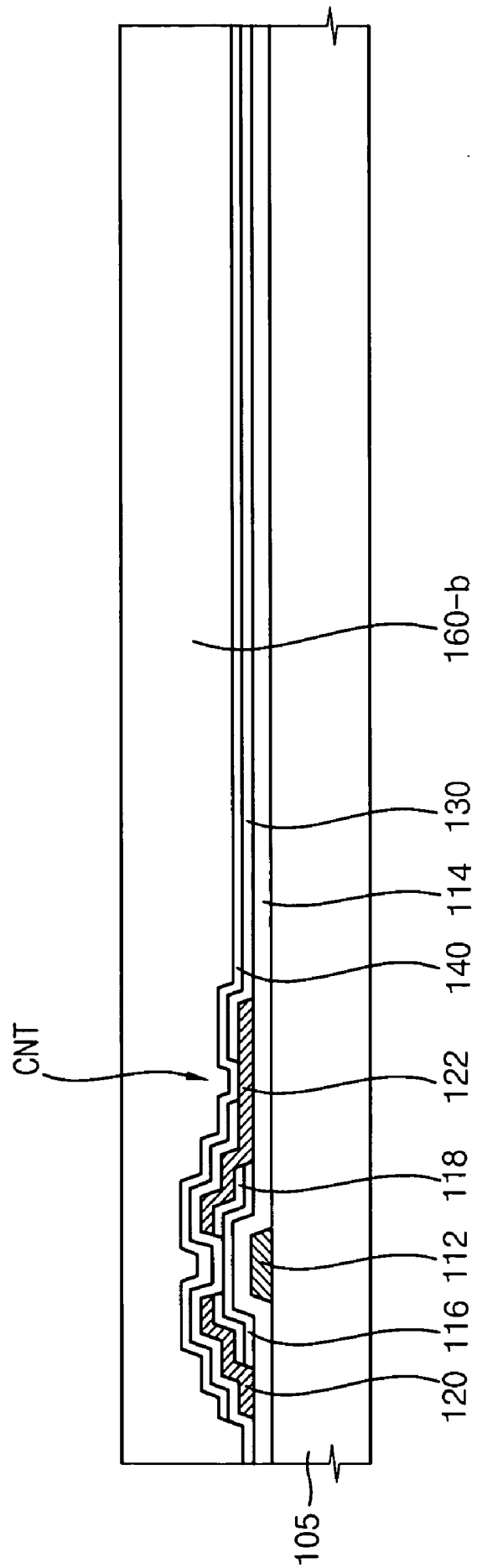

FIG. 3C

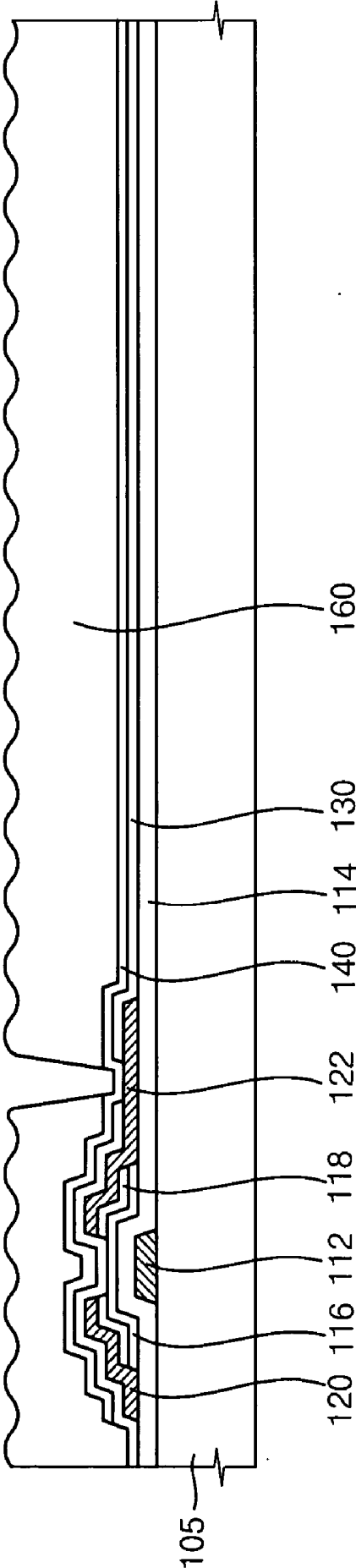

FIG. 3D

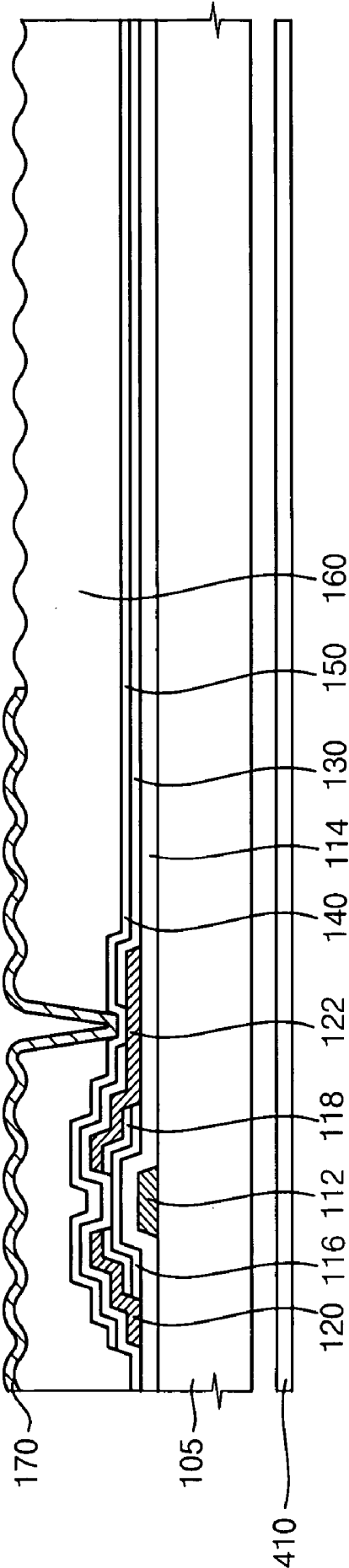

FIG. 3E

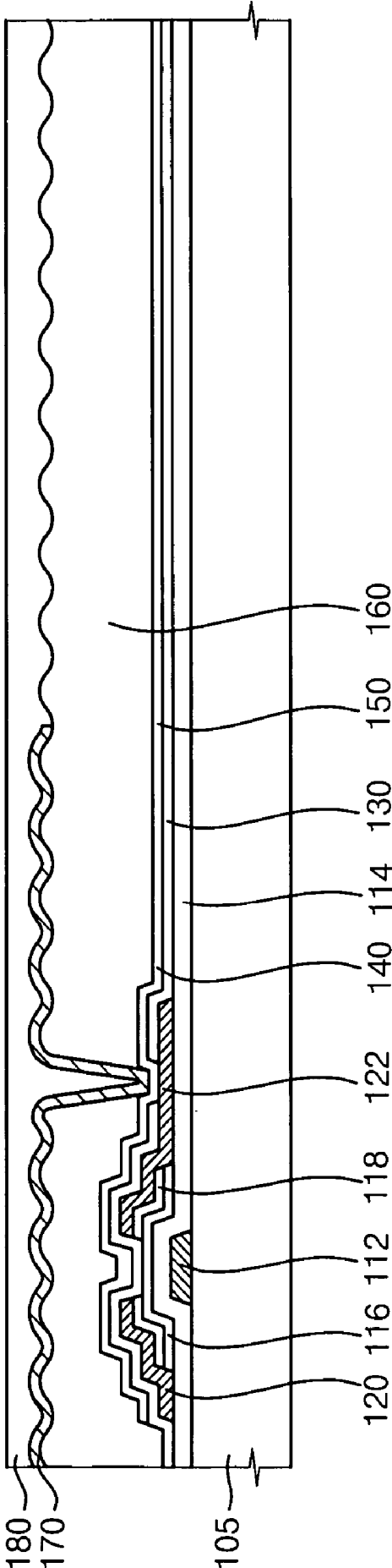

FIG. 3F

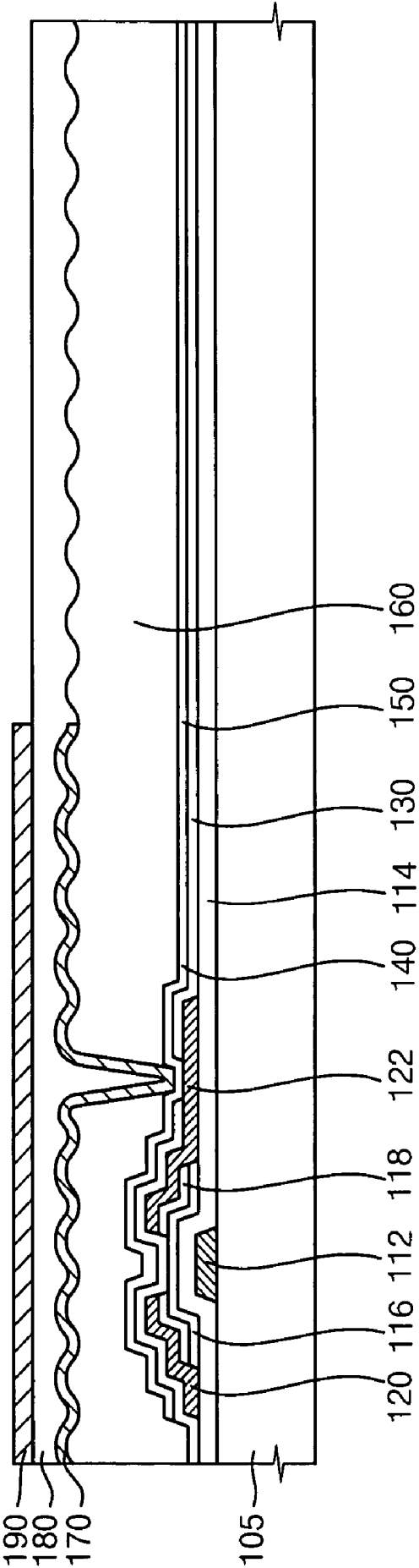

FIG. 3G

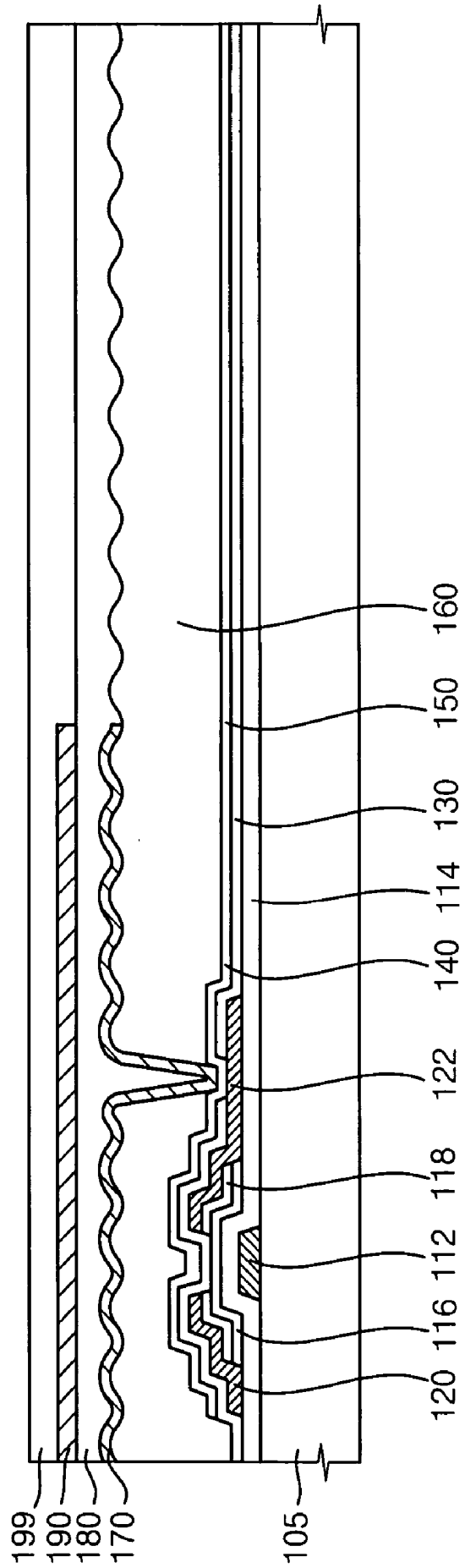

FIG. 4

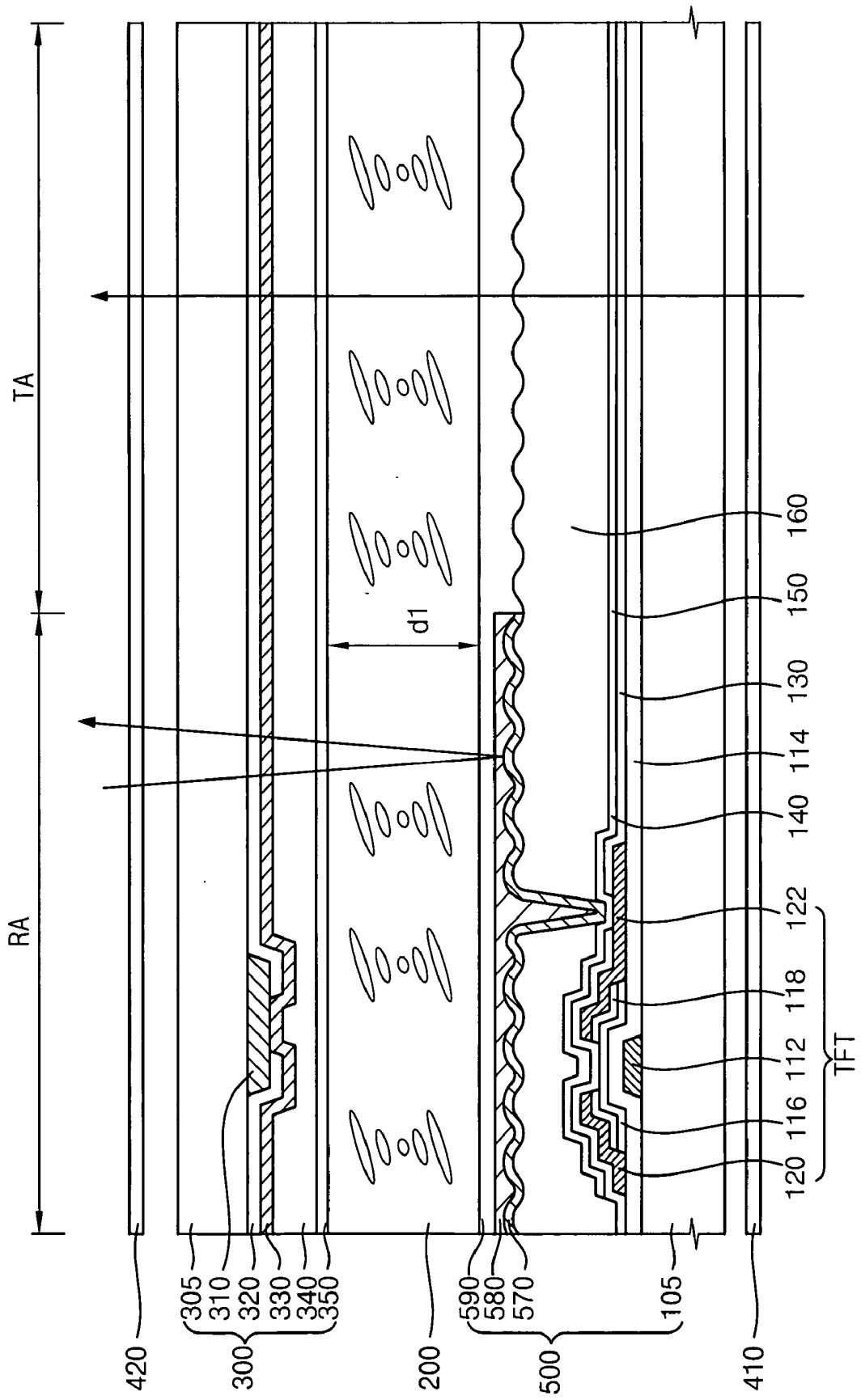

FIG. 5A

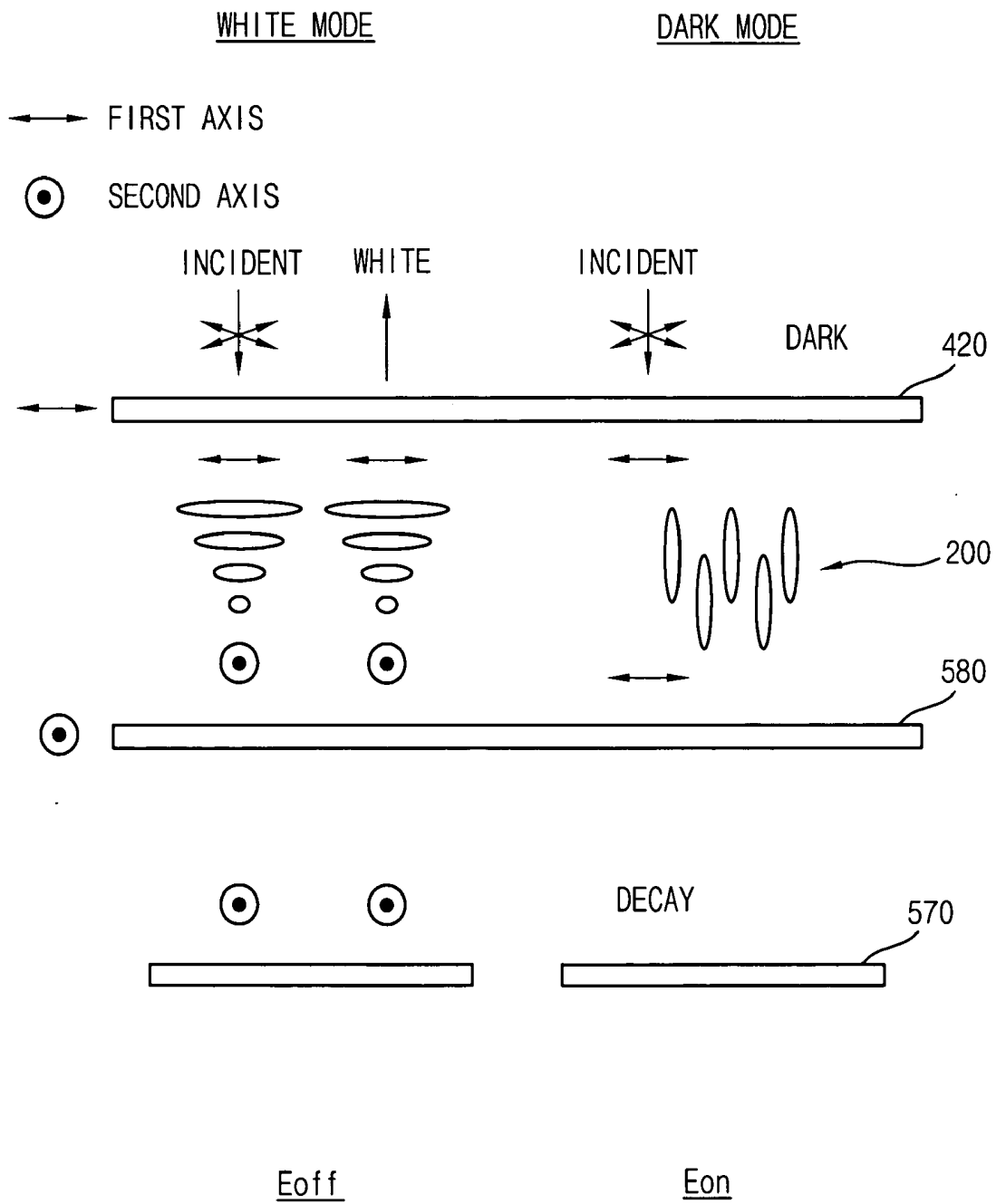

FIG. 5B

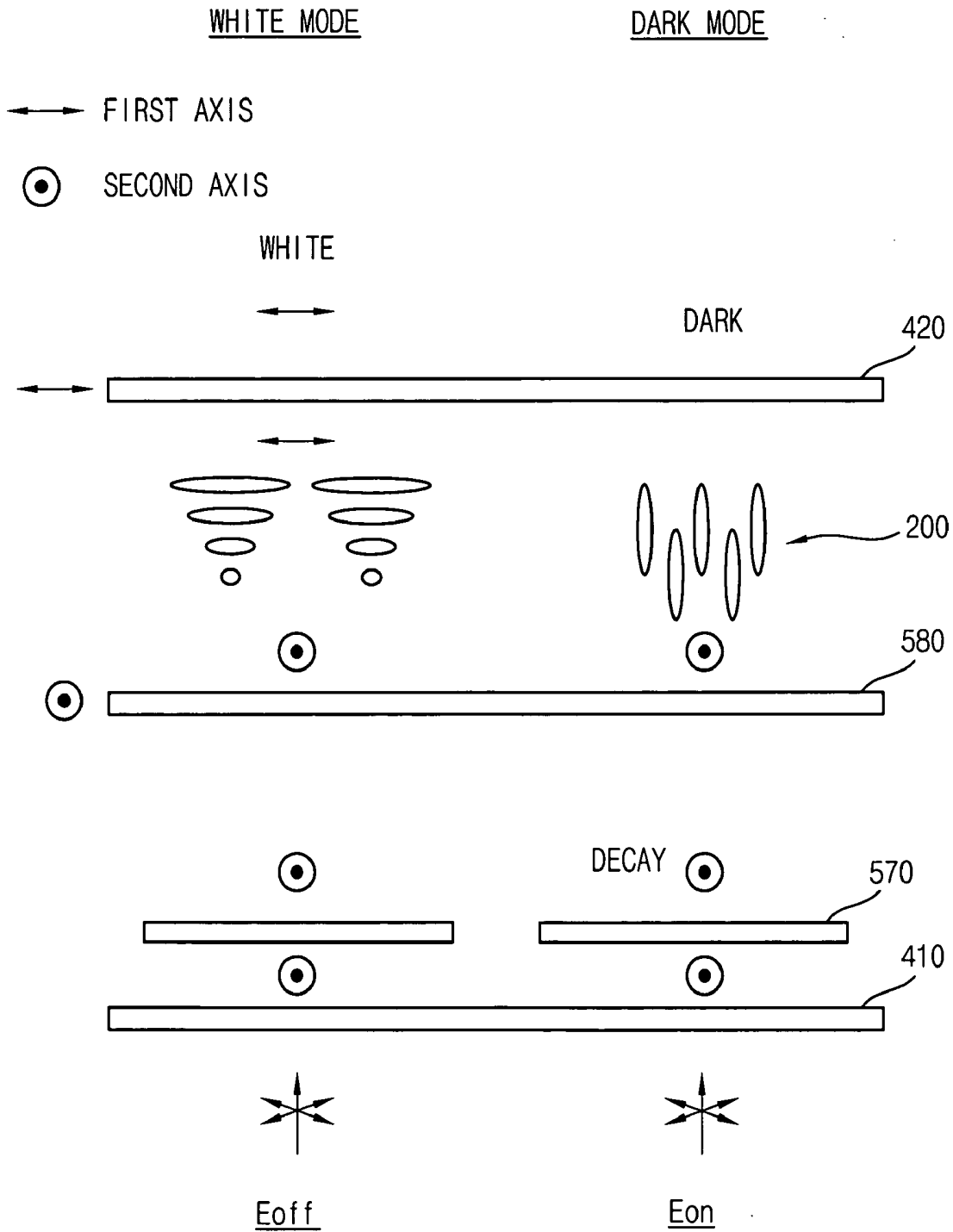

FIG. 6

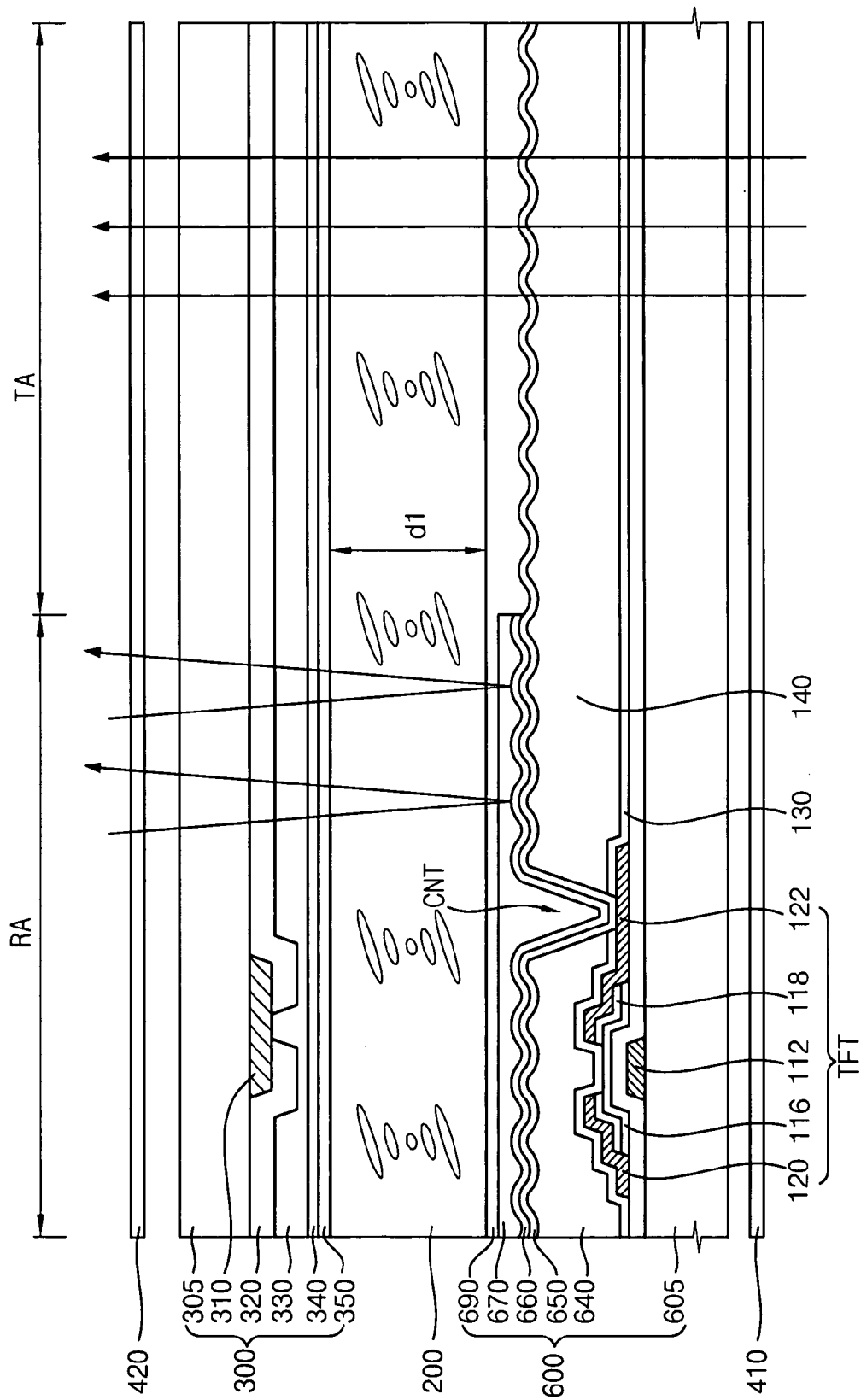

FIG. 7B

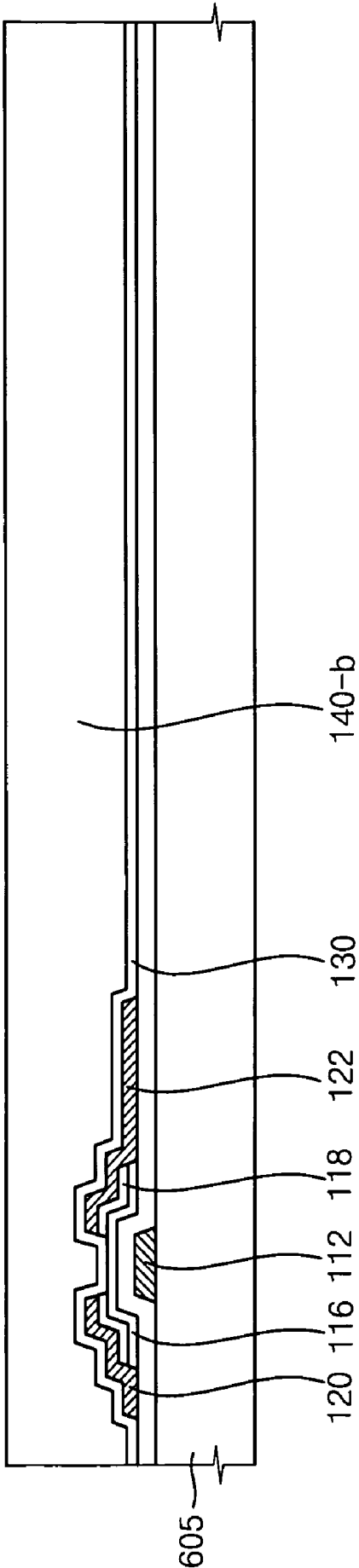

FIG. 7C

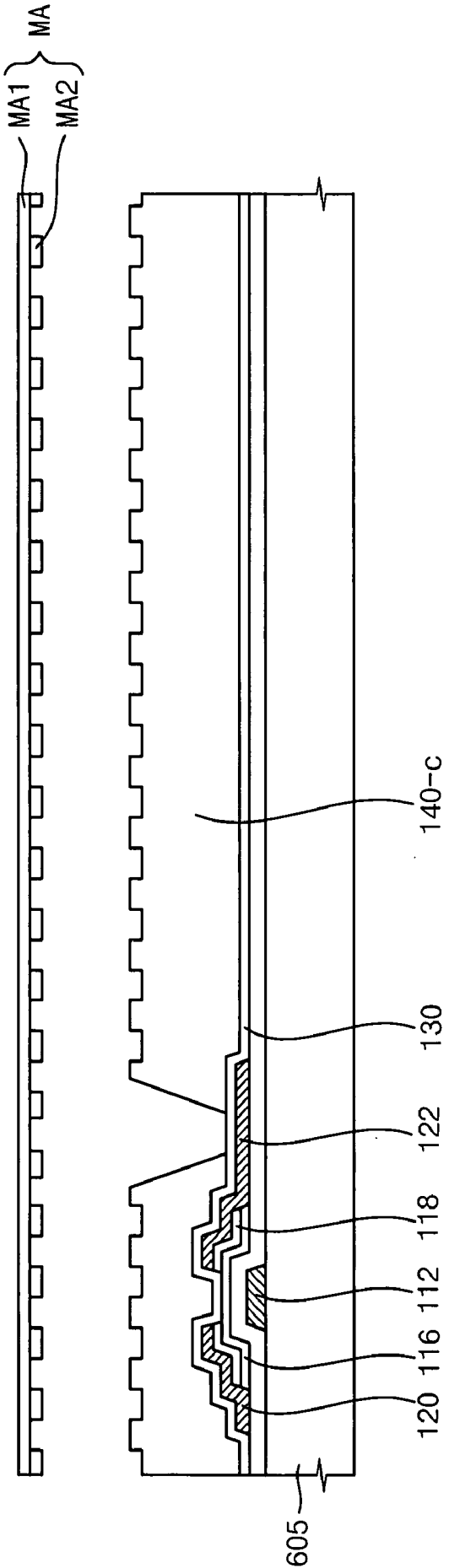

FIG. 7D

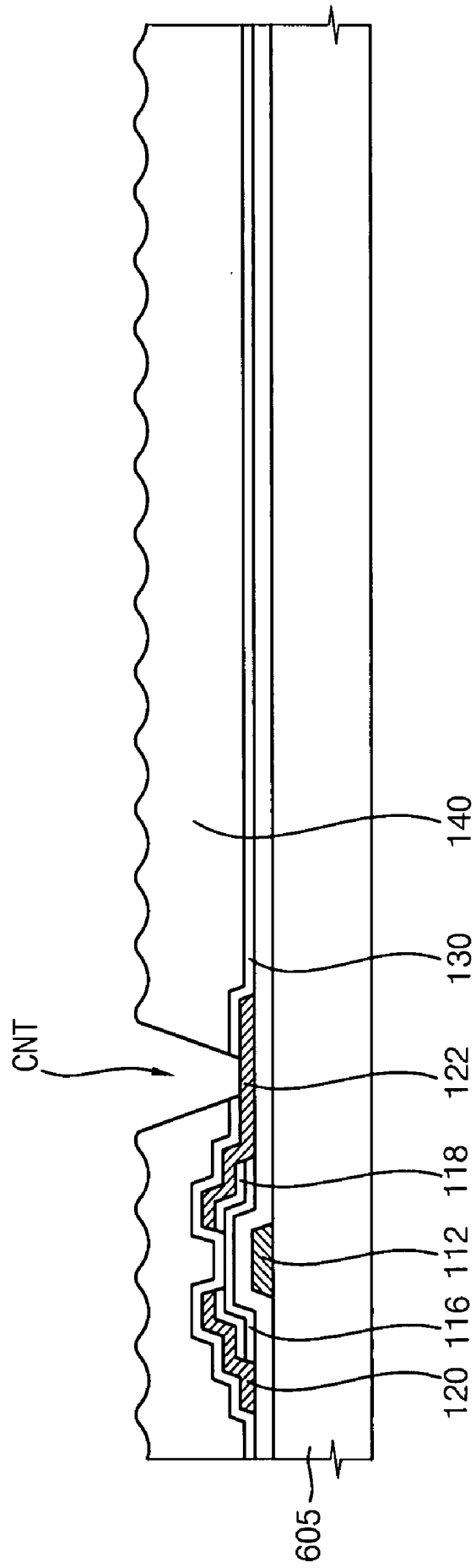

FIG. 7E

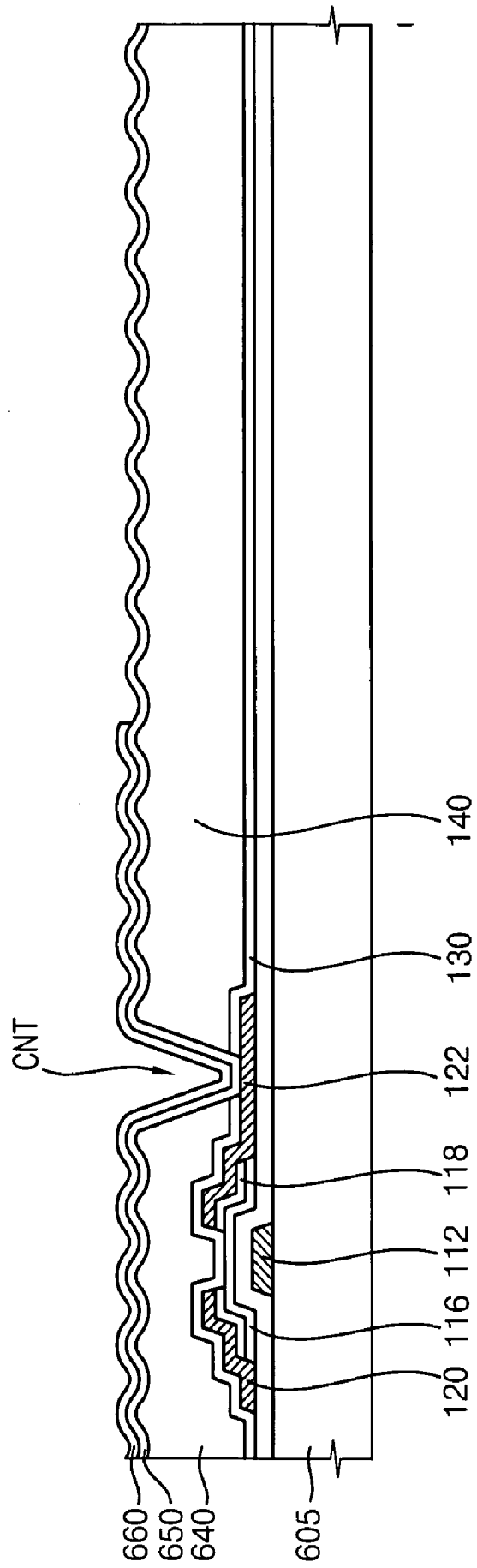

FIG. 7F

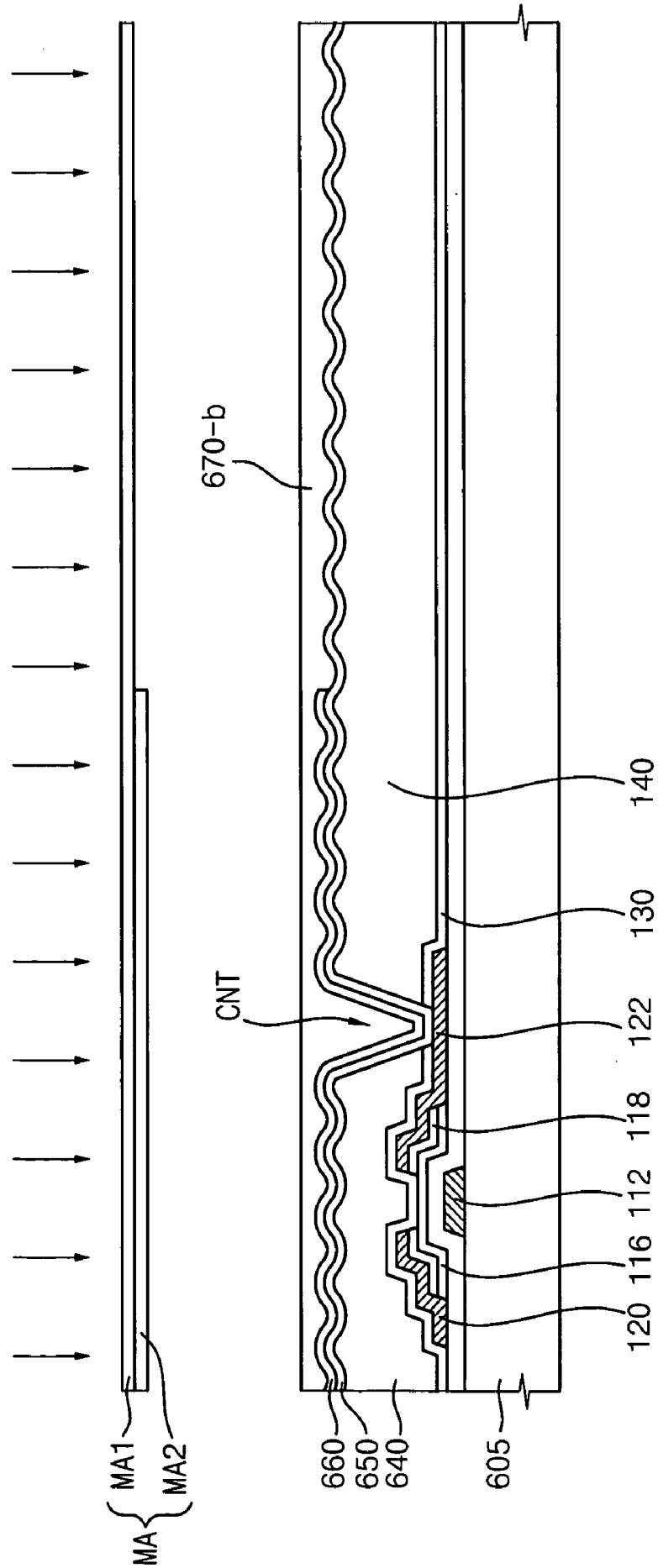

FIG. 7G

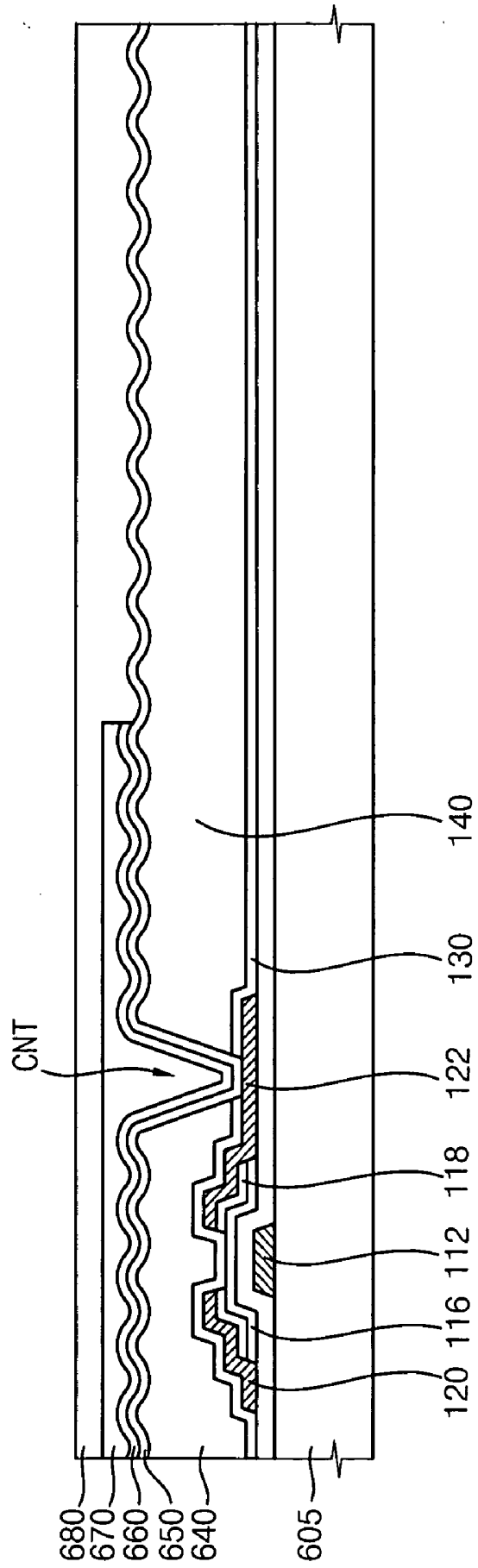

FIG. 9

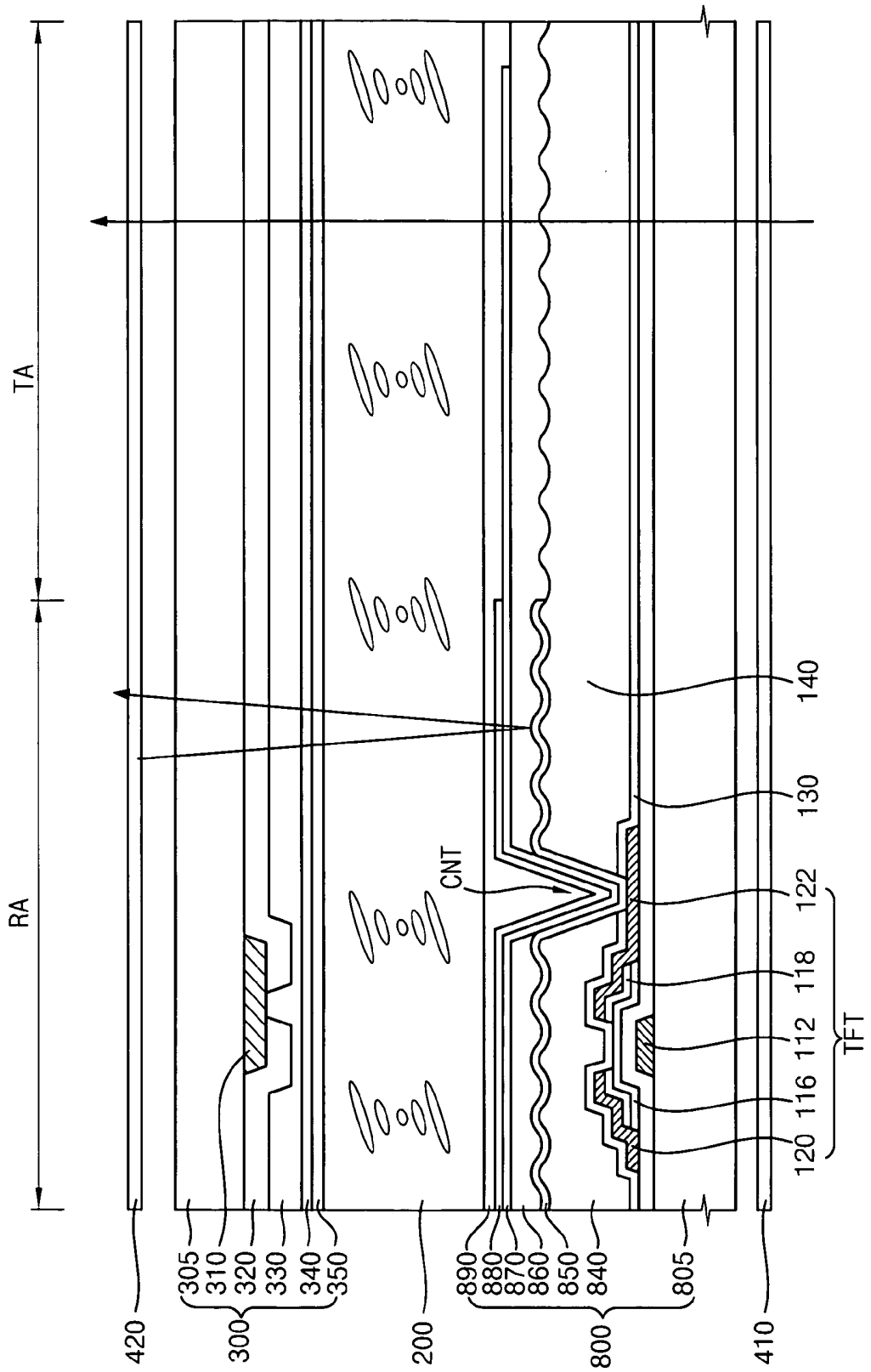

FIG. 10B

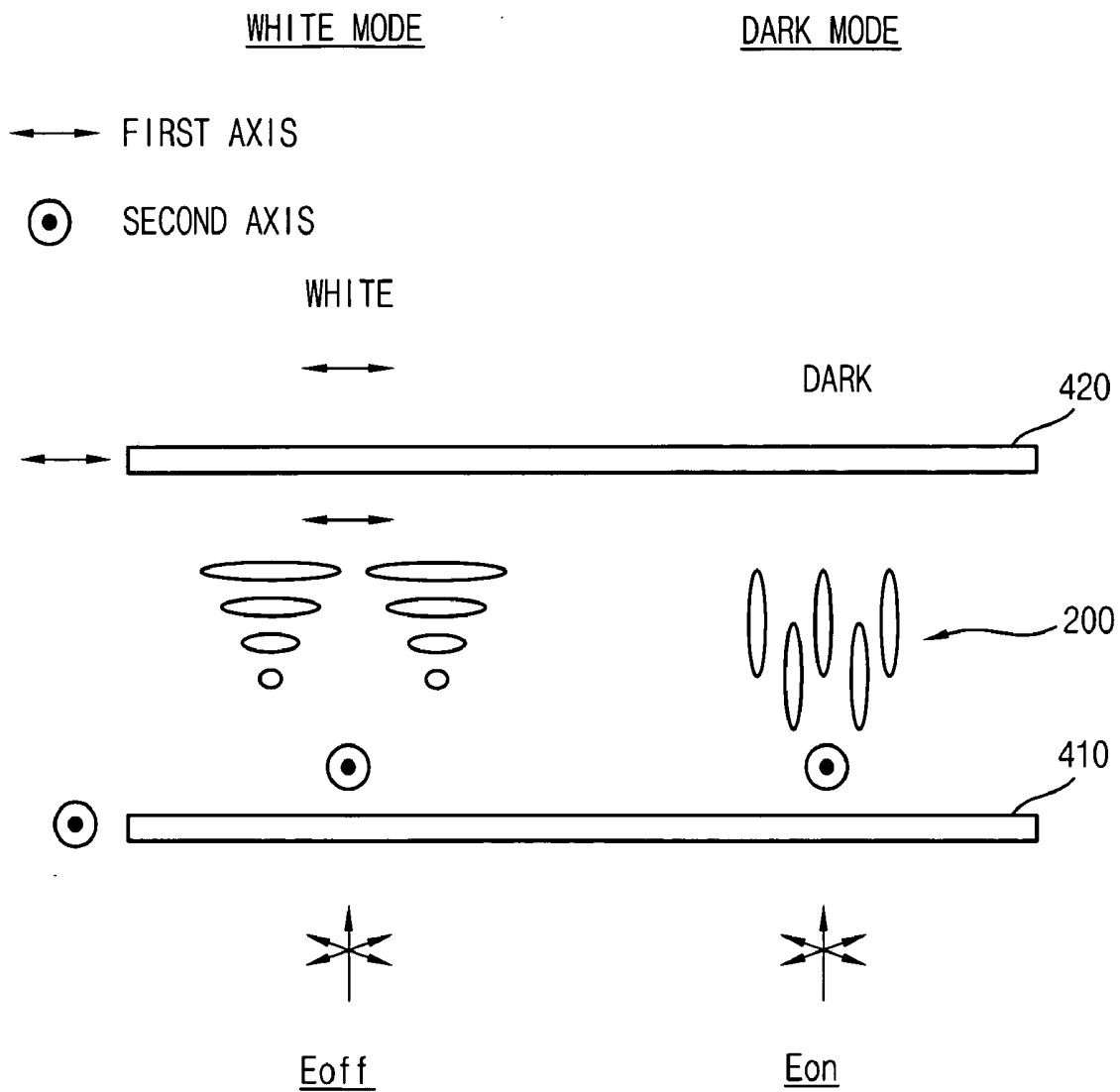

FIG. 11A

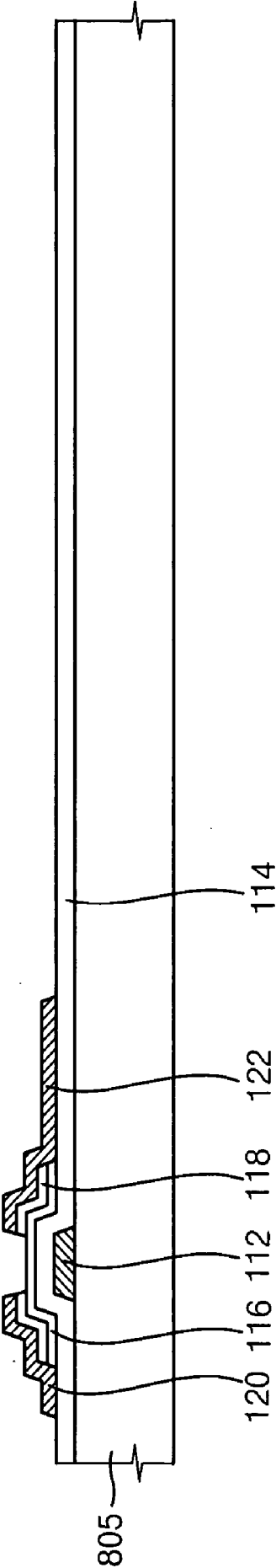

FIG. 11B

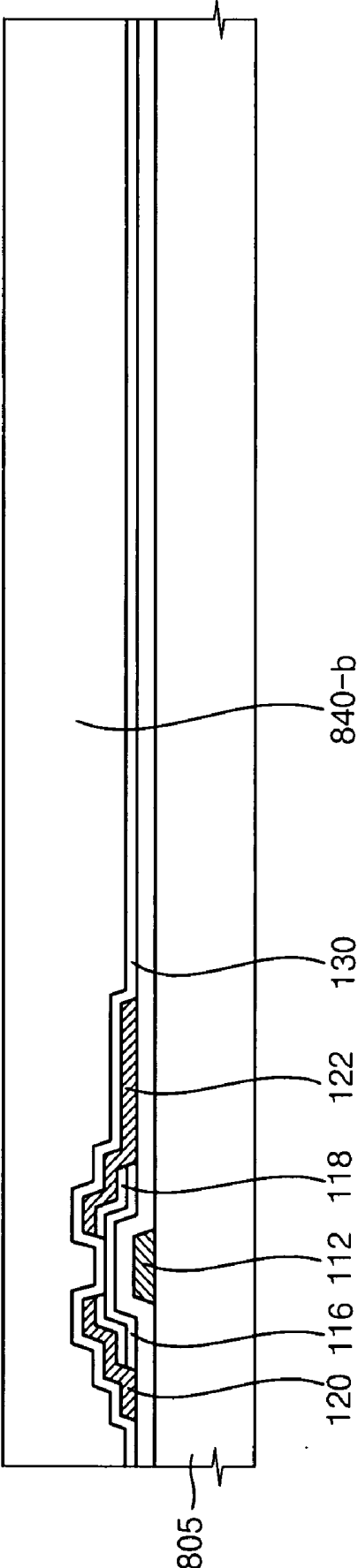

FIG. 11C

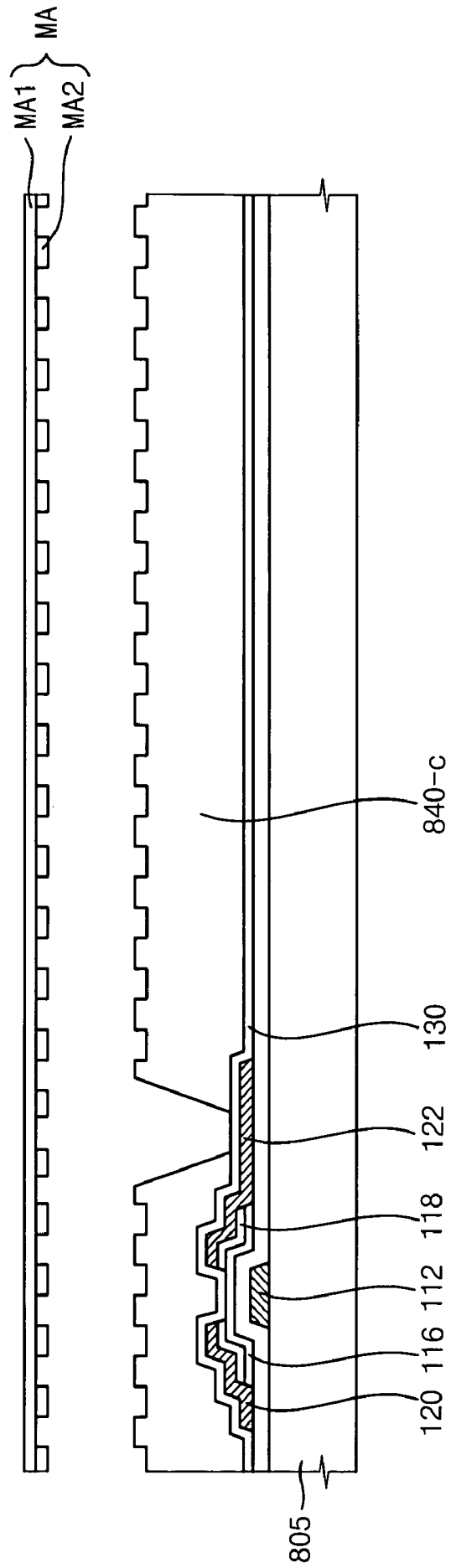

FIG. 11D

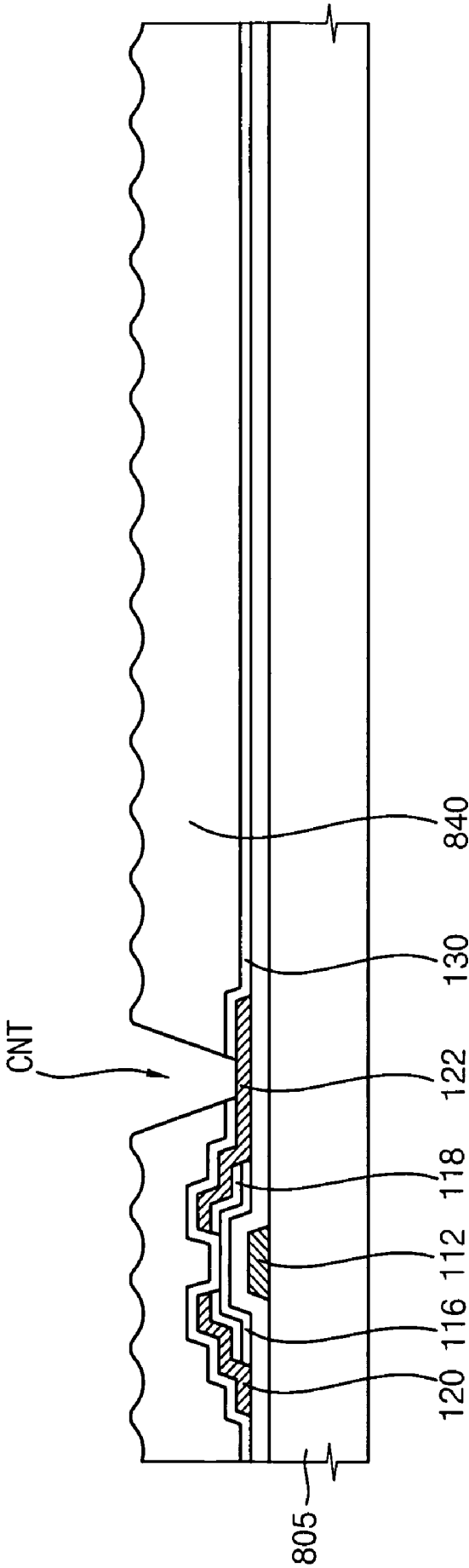

FIG. 11E

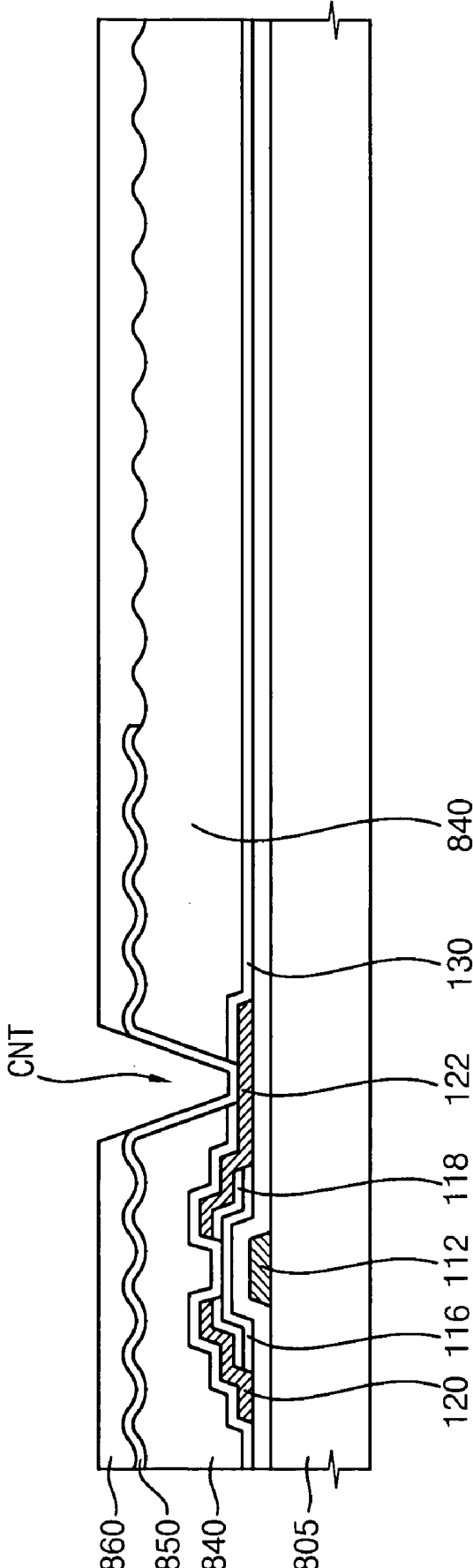

FIG. 11F

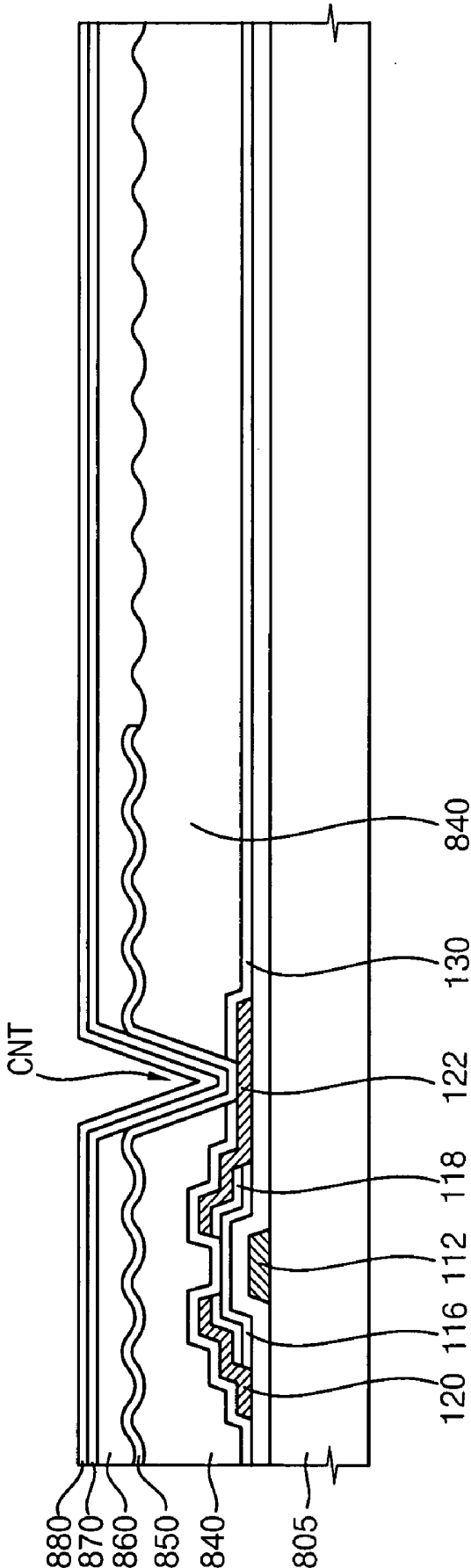

FIG. 11G

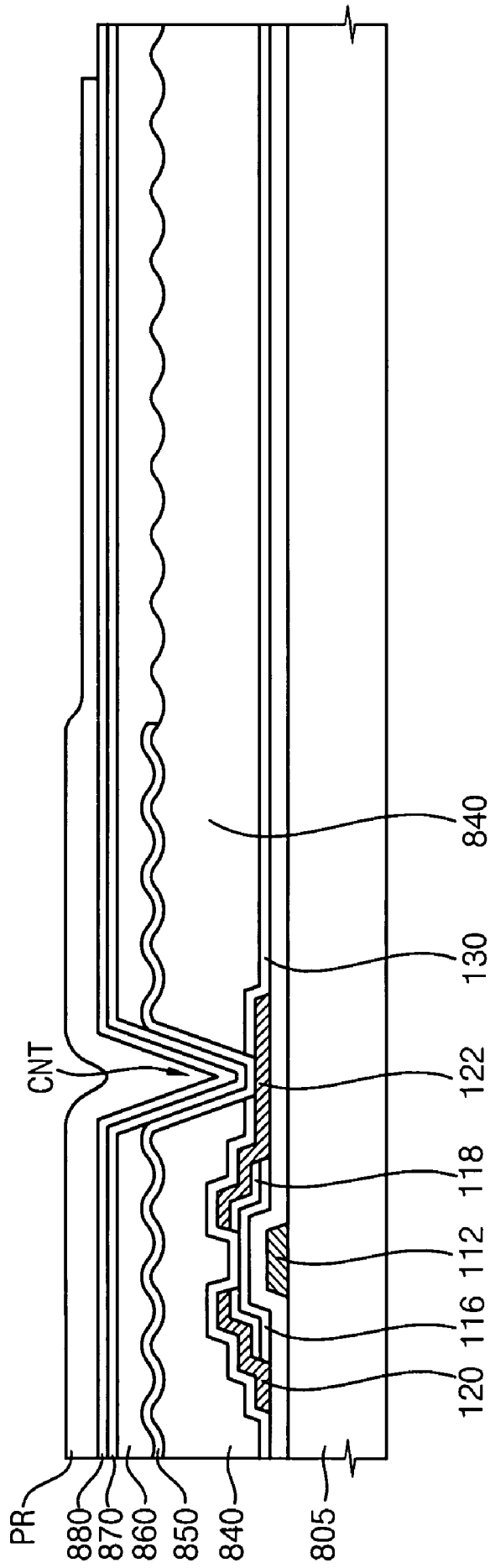

FIG. 11H

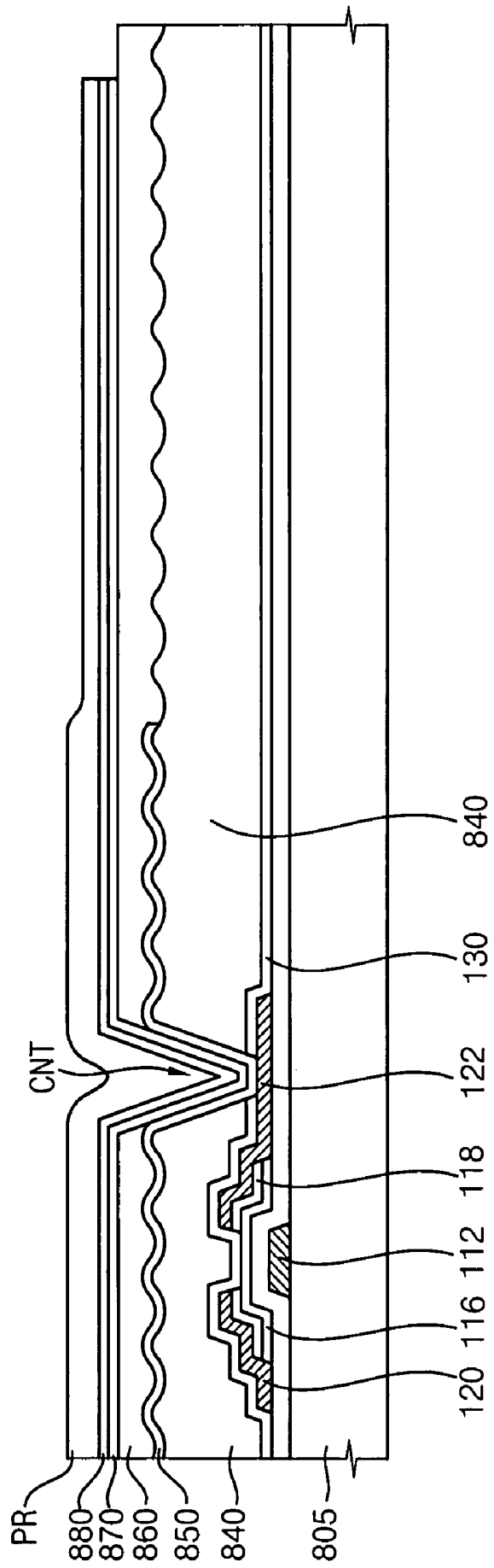

FIG. 11J

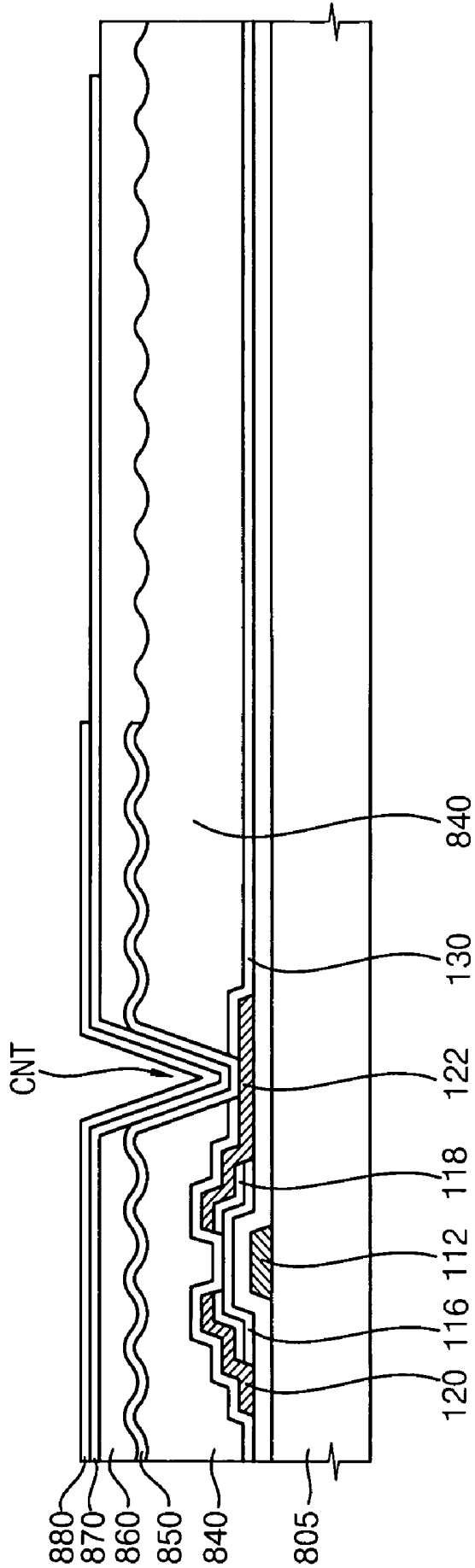

FIG. 12

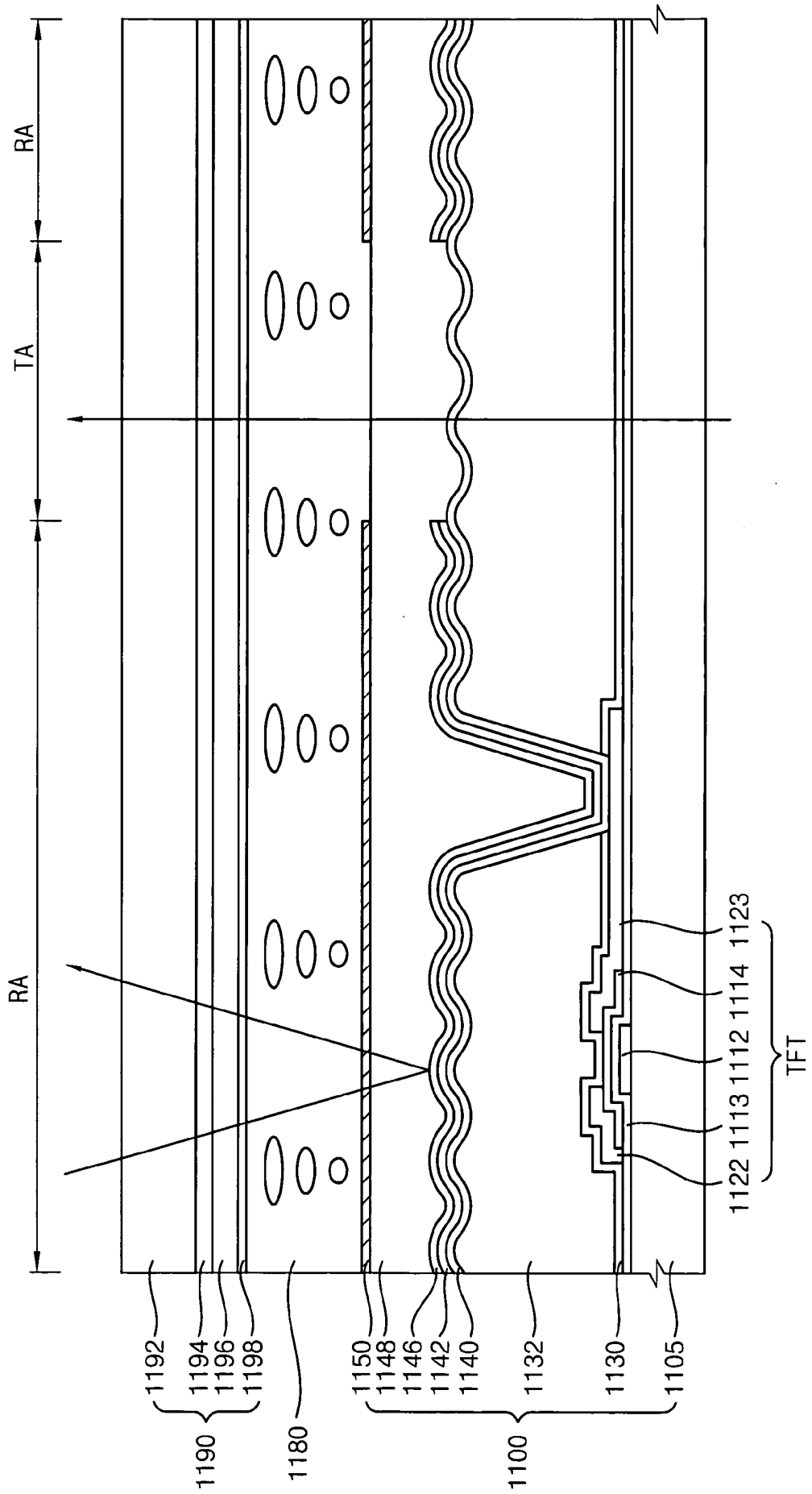

FIG. 13A

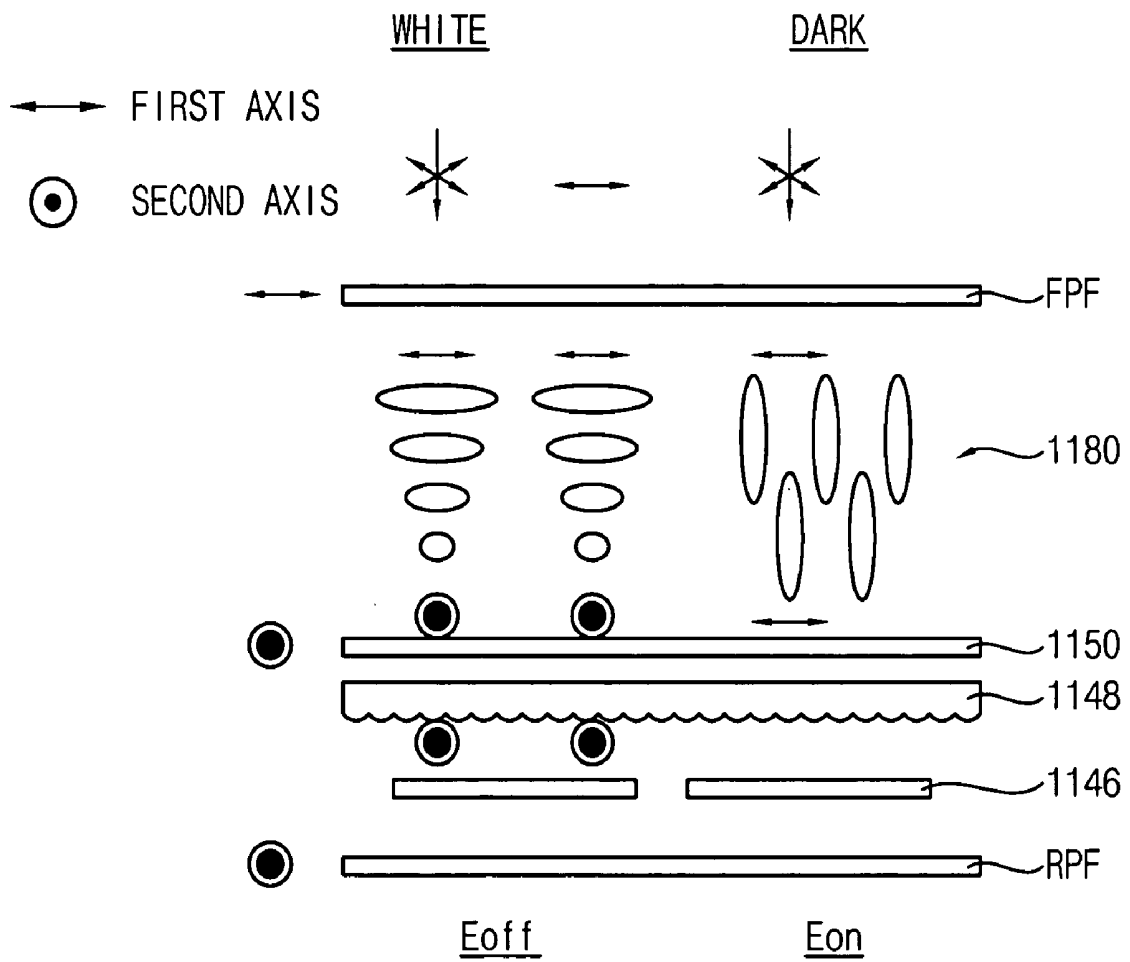

FIG. 13B

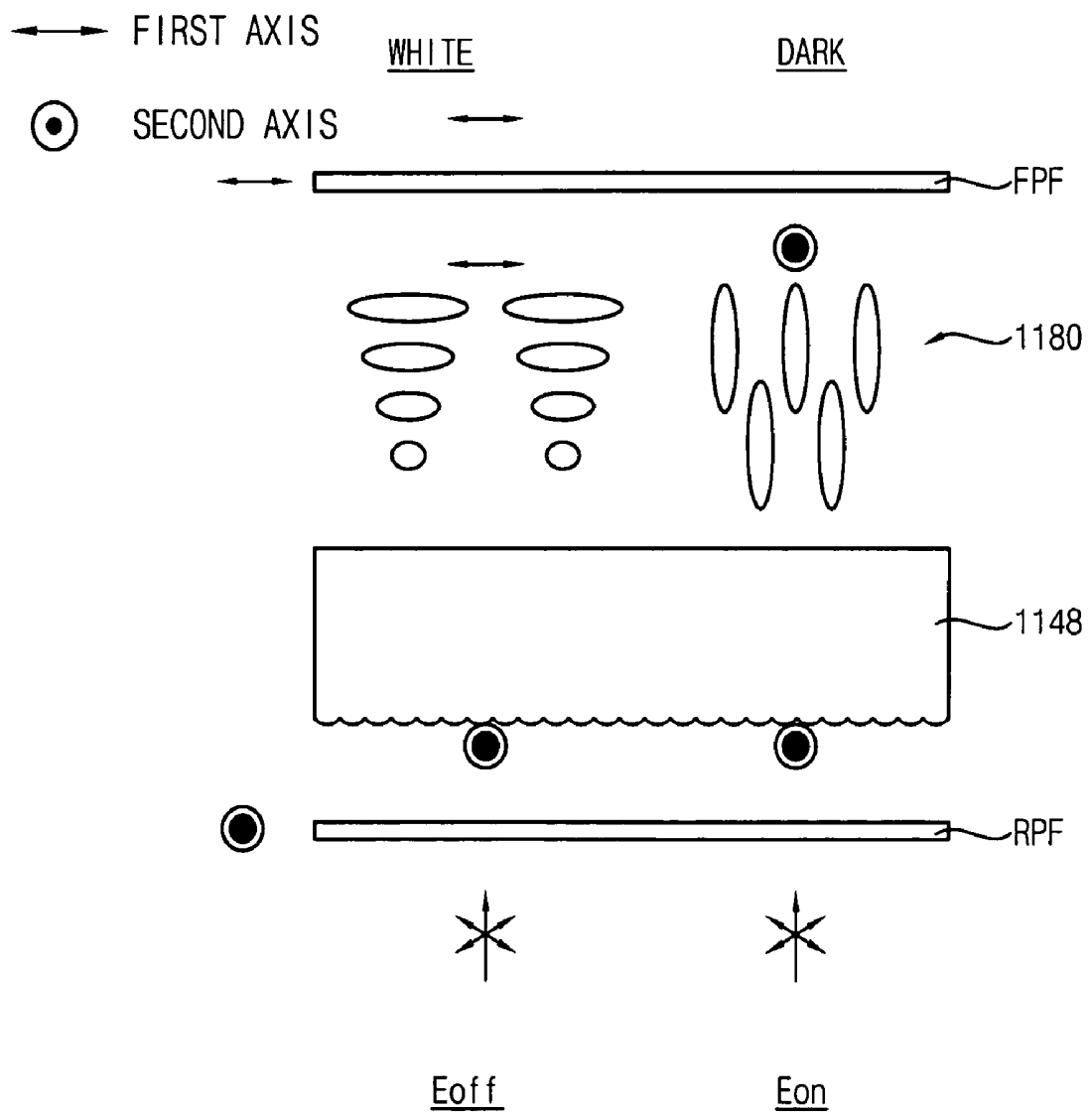

FIG. 14

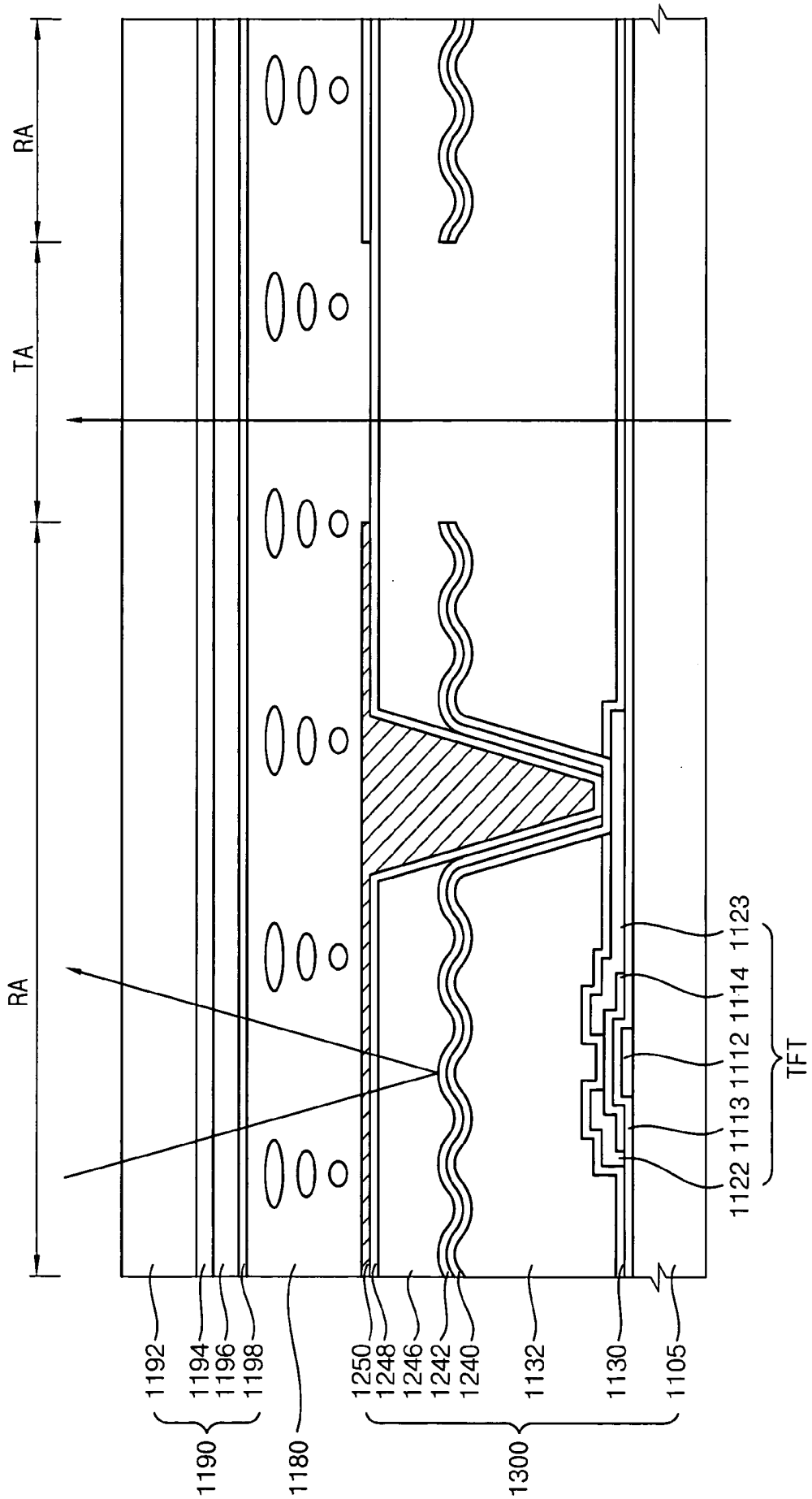

FIG. 15A

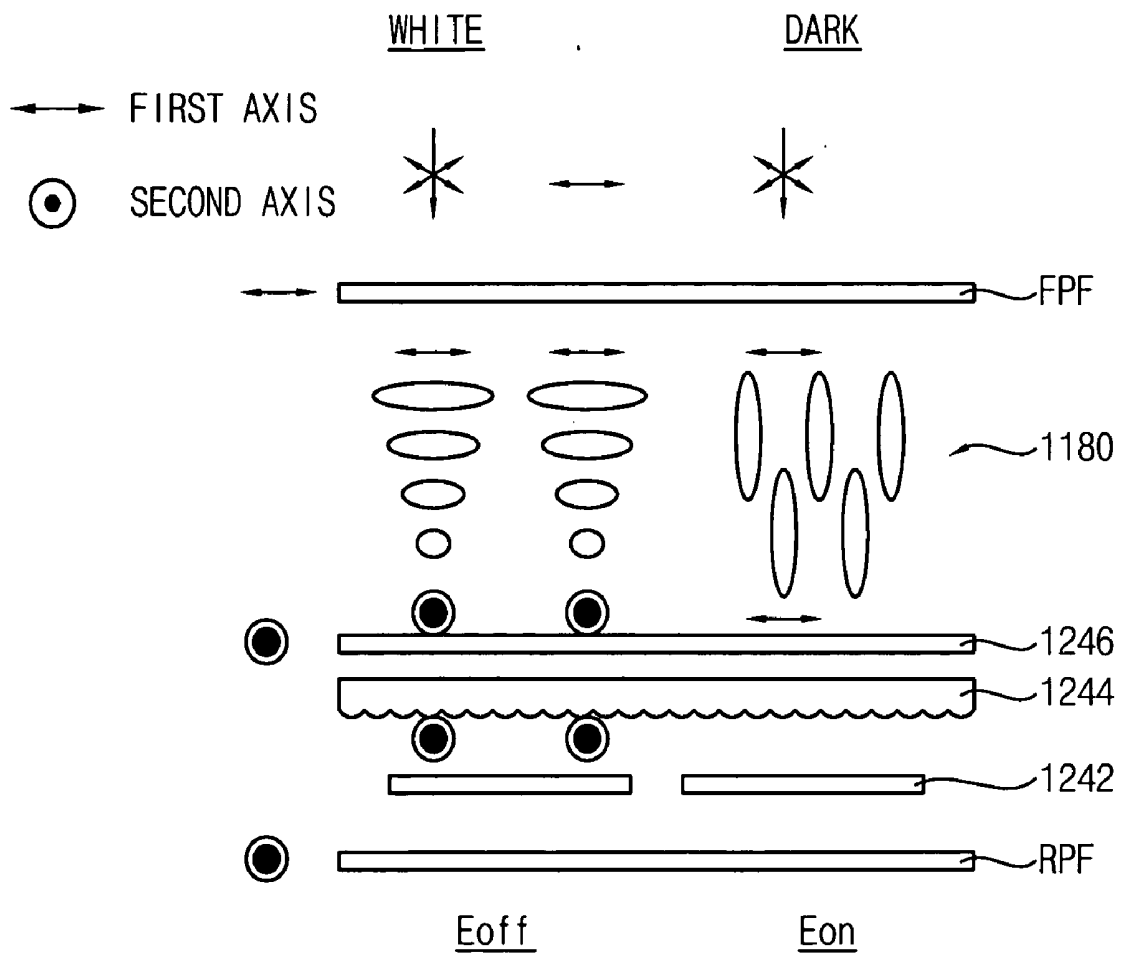

FIG. 15B

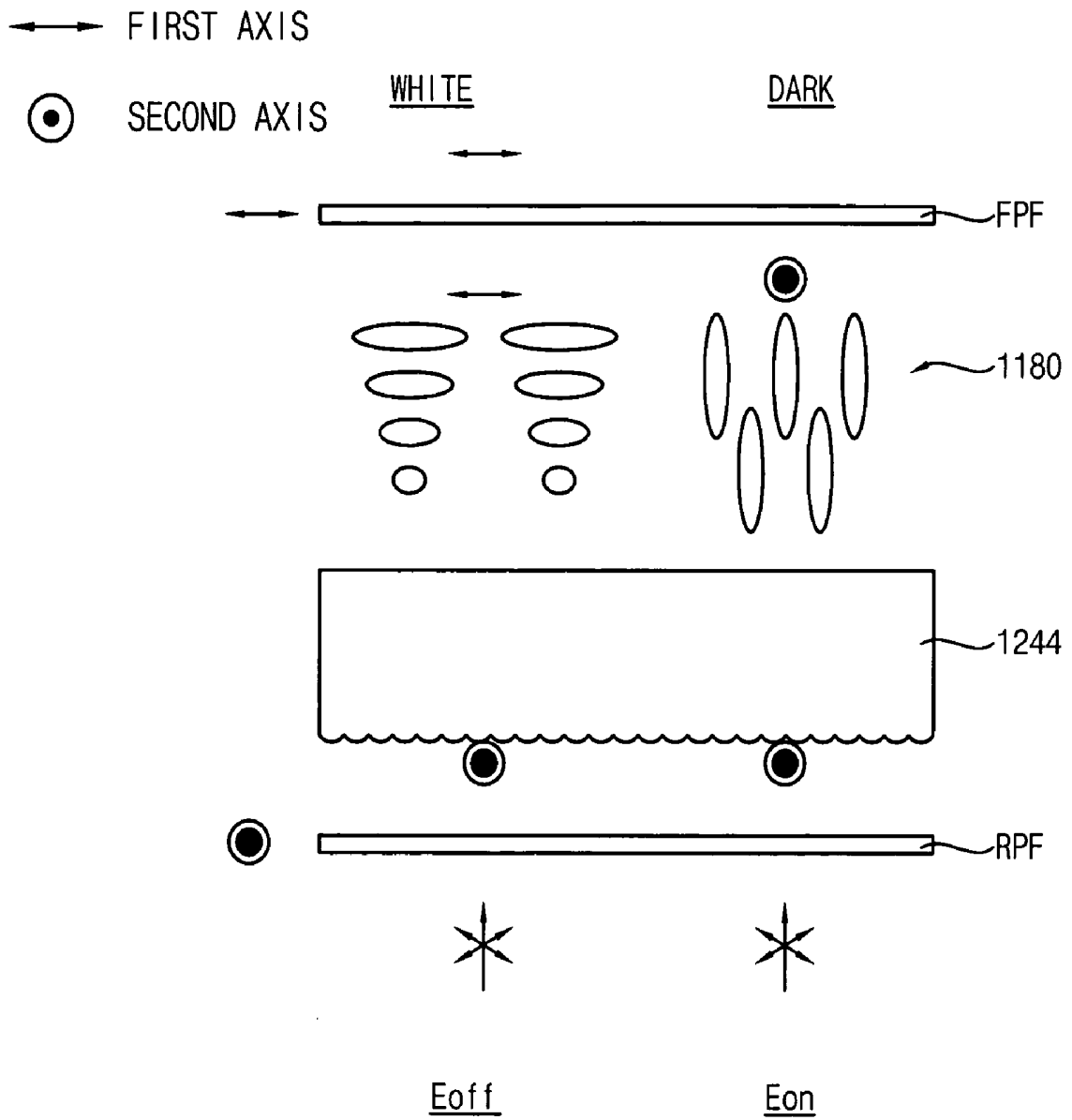

FIG. 16

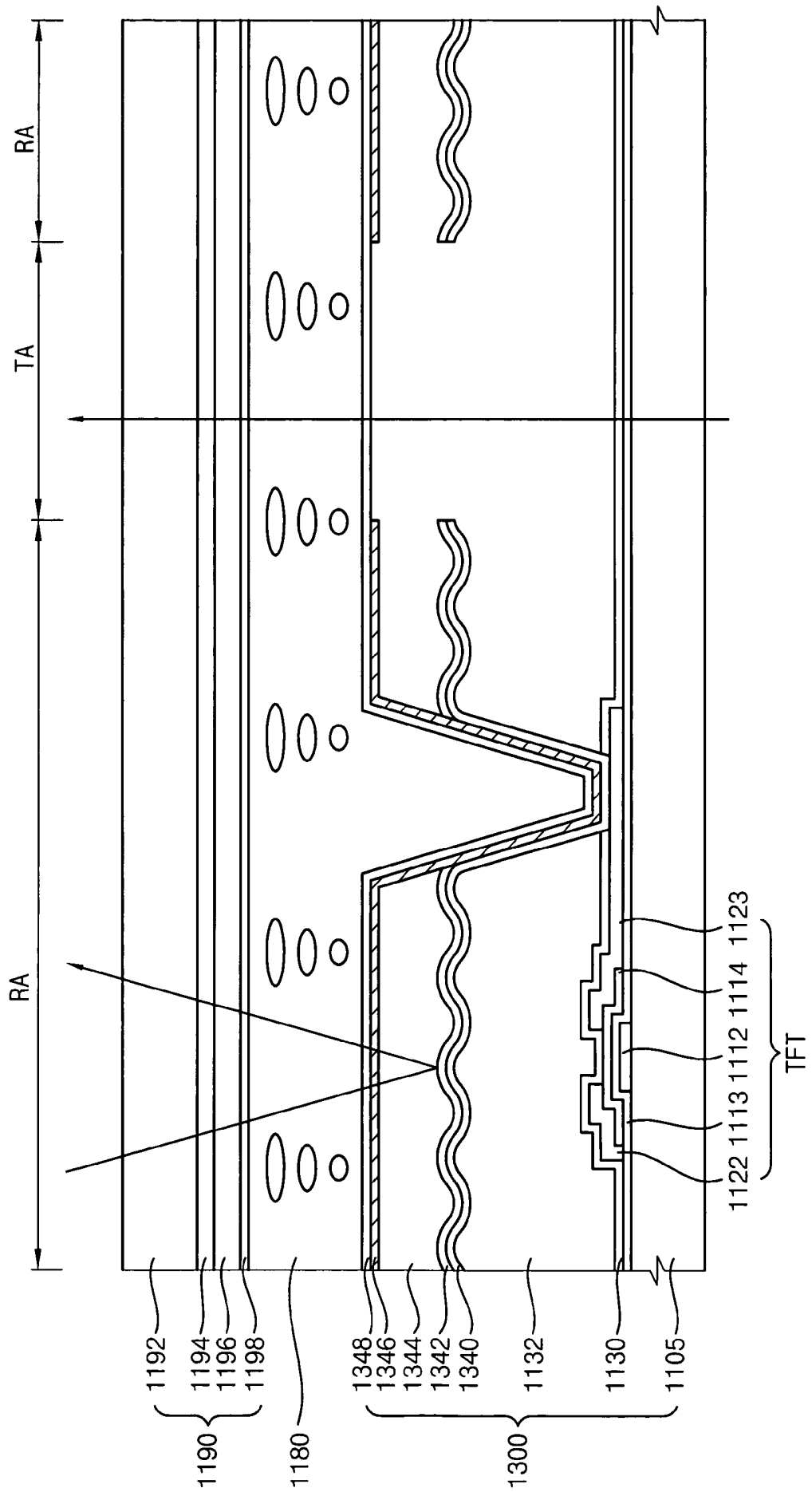

FIG. 17A

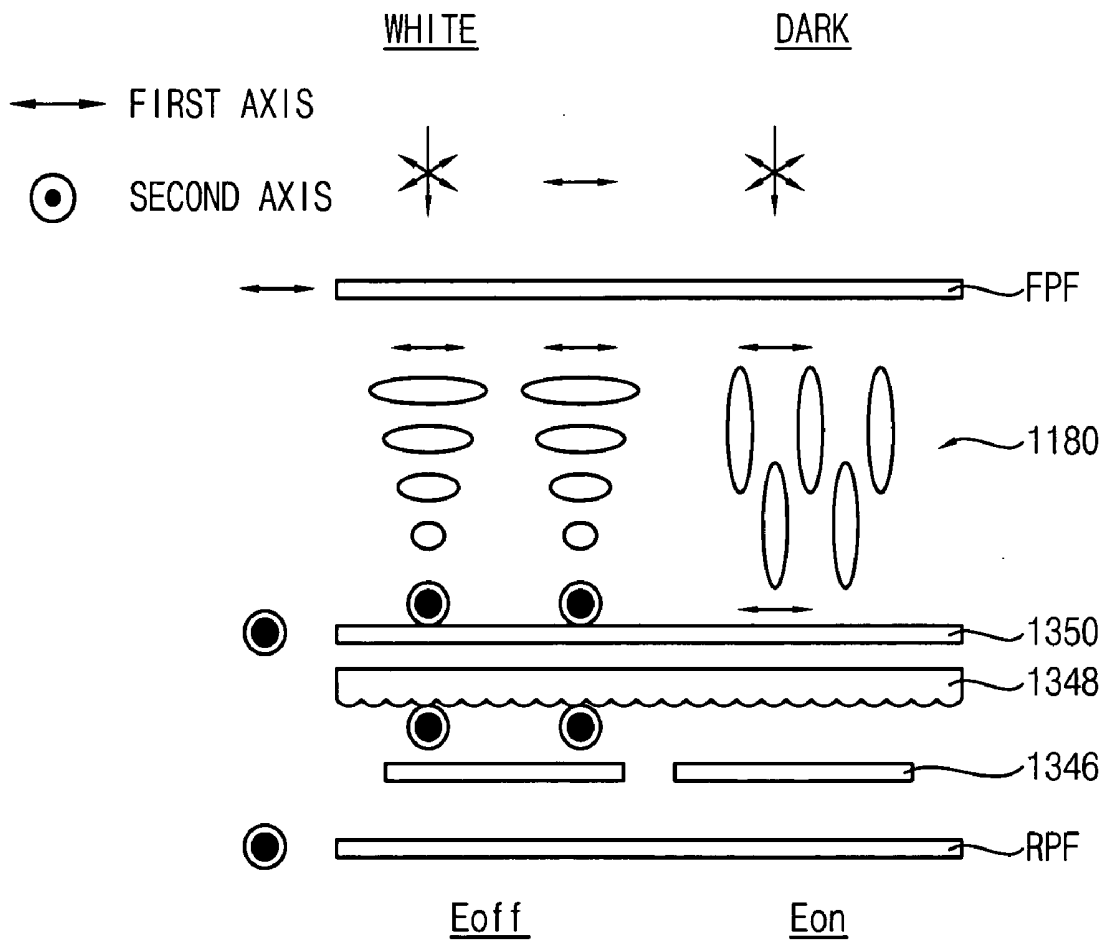
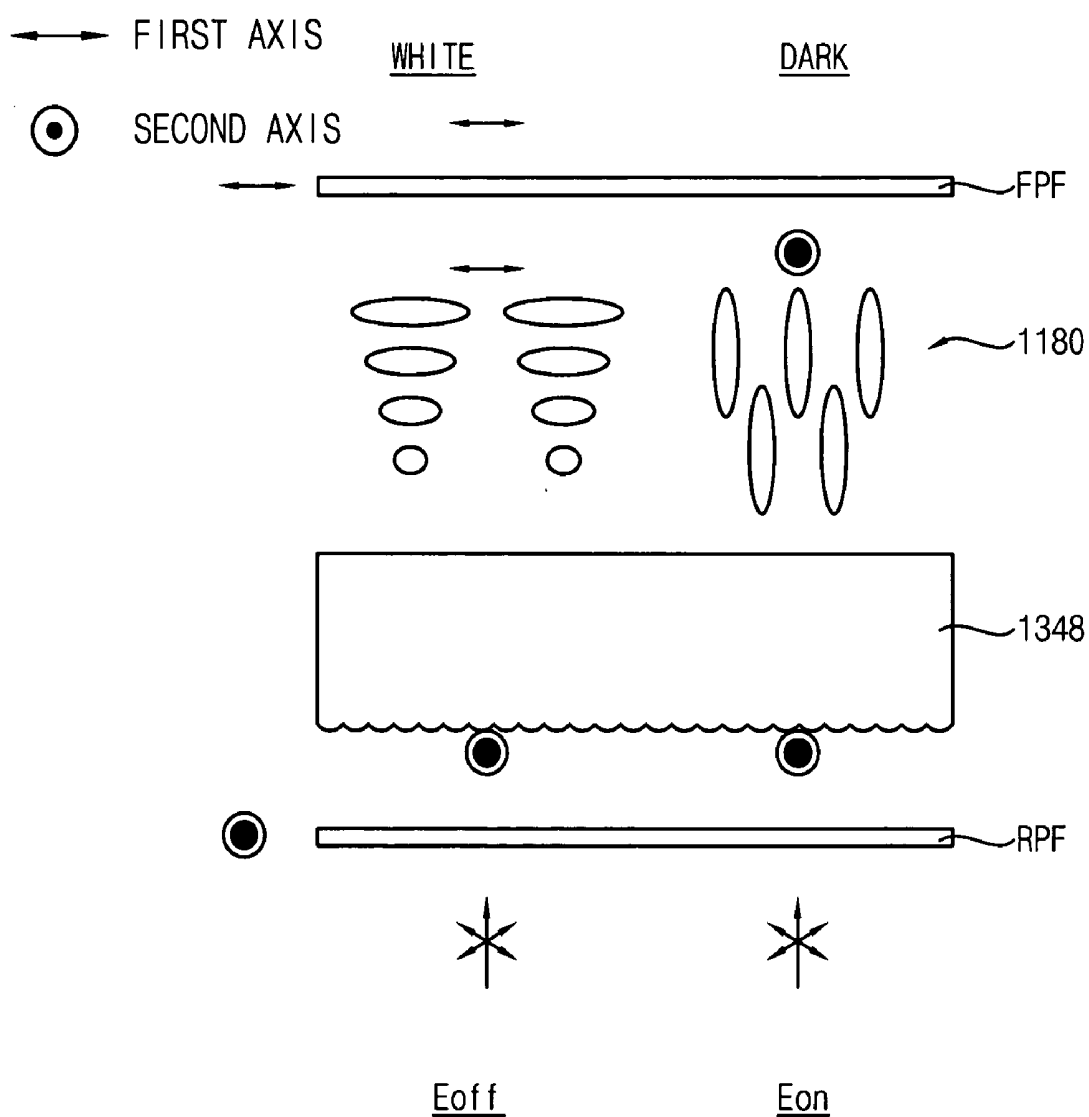

FIG. 17B



**ARRAY SUBSTRATE, METHOD OF
MANUFACTURING THE SAME AND LIQUID
CRYSTAL DISPLAY APPARATUS HAVING THE
SAME**

CROSS-REFERENCE TO RELATED
APPLICATIONS

[0001] This application claims priority to Korean Patent Application No. 2004-104951 filed on Dec. 13, 2004, Korean Patent Application No. 2005-10697 filed on Feb. 4, 2005, and Korean Patent Application No. 2005-10929 filed on Feb. 5, 2005, the contents of which are herein incorporated by reference in their entirety.

BACKGROUND OF THE INVENTION

[0002] 1. Field of the Invention

[0003] The present invention relates to an array substrate, a method of manufacturing the array substrate and a liquid crystal display apparatus having the array substrate.

[0004] 2. Description of the Related Art

[0005] Generally, a transfective liquid crystal display (LCD) apparatus, having a twisted nematic configuration for its liquid crystal molecules, includes a plurality of pixels. Each of the pixels has a reflective plate and a transmissive window. Two factors to consider when designing a transfective LCD apparatus are the contrast ratio and white color luminance for the LCD apparatus.

[0006] Typically, a transfective LCD apparatus has a double cell gap structure. In other words, the cell gap of a transmissive region is double the cell gap of a reflective region of the LCD apparatus.

[0007] The transfective LCD apparatus having the double cell gap structure displays an optimized image. However, it is more difficult to manufacture the double cell gap structure as compared to the single gap structure. Even with a transfective LCD apparatus having the single gap structure, white color luminance of a transmissive mode may still be reduced.

[0008] To enhance the reflectivity of a transfective LCD apparatus having a single gap structure, the surface area of the reflective plate of the LCD apparatus may be increased. For example, embossing patterns may be formed at the reflective plate for increasing the surface area of the reflective plate, and thereby also enhancing the reflectivity of the LCD apparatus. When the transfective LCD apparatus being used includes a reflective plate having embossing patterns, it is also preferable to dispose an inner polarization layer on the outside of the array substrate of the LCD apparatus.

[0009] In addition, each of protrusions of the embossing patterns preferably has, for example, roughly circular shape when viewed on a plane. Moreover, each of the protrusions preferably has a height of about 0.5 μm , and a width of substantially equal to or less than about 15 μm .

[0010] Further, to embody the transfective LCD apparatus having the single cell gap structure and a reflective plate having the embossing patterns, a wavegrid polarizer layer having a thickness in a range of about 0.1 μm to about 0.8 μm is formed inside of the liquid crystal cell. However, due

to surface tension formed between a surface of the embossing patterns and the inner polarization layer, the arrangement of a wavegrid polarizer of the wavegrid polarizer layer is disrupted to induce light leakage

[0011] from the LCD apparatus. In addition, the light leakage further increases when the embossing patterns are deepened.

[0012] Therefore, a need exists for a transfective LCD apparatus including a reflective plate having embossing patterns and an inner polarization layer, and which is capable of reducing light leakage from the LCD apparatus.

SUMMARY OF THE INVENTION

[0013] In an exemplary embodiment of the present invention, the array substrate includes a transparent substrate, a switching device, an insulation layer, a pixel electrode, a reflective plate and an inner polarization layer. The transparent substrate has a reflective region and a transmissive region. The switching device is formed in the reflective region. The insulation layer is formed on the transparent substrate to cover the switching device and has a contact hole that exposes a portion of an electrode of the switching device. The pixel electrode is electrically connected to the electrode of the switching device through the contact hole. The reflective plate is electrically connected to the pixel electrode and is disposed at the reflective region. The inner polarization layer covers the reflective plate.

[0014] In another exemplary embodiment of the present invention, the array substrate includes a transparent substrate, a switching device, an insulation layer, a reflective plate, a transparent electrode layer and an inner polarization layer. The transparent substrate has a reflective region and a transmissive region. The switching device is formed on the transparent substrate. The switching device includes a gate electrode, a drain electrode and a source electrode. The insulation layer is formed on the transparent substrate to cover the switching device and has a contact hole that exposes a portion of a drain electrode of the switching device. The insulation layer has an upper surface that has substantially the same height throughout the reflective and transmissive regions relative to the transparent substrate. The reflective plate is electrically connected to the drain electrode of the switching device through the contact hole and is disposed at the reflective region. The transparent electrode layer is electrically connected to the reflective plate. The inner polarization layer is formed on the transparent electrode layer of the reflective region to cover the reflective plate.

[0015] In still another exemplary embodiment of the present invention, the array substrate includes a substrate, a switching device, a transparent electrode layer, a reflective plate, a planarization layer and an inner polarization layer. The switching device is formed on the substrate. The switching device includes a gate electrode, a source electrode and a drain electrode. The transparent electrode layer is electrically connected to the drain electrode of the switching device. The reflective plate is electrically connected to the drain electrode. The planarization layer is formed on the reflective plate. The inner polarization layer is formed on the planarization layer.

[0016] In another exemplary embodiment of the present invention, a method of manufacturing an array substrate is

provided, which includes an insulation layer being formed on a substrate having a switching device. The insulation layer has a contact hole that exposes a portion of a drain electrode of the switching device. A transparent electrode layer that is electrically connected to the drain electrode through the contact hole is formed. A reflective plate that is electrically connected to the transparent electrode is formed. An inner polarization layer is formed on the reflective plate.

[0017] In another exemplary embodiment of the present invention, a method of manufacturing an array substrate is provided, which includes a switching device having a gate electrode, a source electrode and a drain electrode being formed on a substrate having a reflective region and a transmissive region. An insulation layer having a contact hole that exposes a portion of the drain electrode of the switching device is formed on the substrate. A reflective plate that is electrically connected to the drain electrode through the contact hole is formed at the reflective region. A planarization layer is formed on the insulation layer of the transmissive region and the reflective plate of the reflective region. The planarization layer has a via-hole corresponding to the contact hole. A transparent electrode layer is formed on the planarization layer that is electrically connected to the reflective plate through the via-hole. An inner polarization layer is formed on the transparent electrode layer. A photoresist layer having a first thickness at the transmissive region and a second thickness that is thicker than the first thickness is formed at the reflective region. The photoresist layer is etched such that the photoresist layer of the reflective region is remained and the photoresist layer of the transmissive region is removed. The transparent electrode layer and the inner polarization layer of the transmissive region are removed by using the photoresist layer of the reflective region.

[0018] In another exemplary embodiment of the present invention, a liquid crystal display (LCD) apparatus is provided. The LCD apparatus includes a first substrate, a second substrate and a liquid crystal layer. The second substrate is combined with the first substrate. The second substrate includes a reflective plate, a pixel electrode and an inner polarization layer covering the reflective plate. The liquid crystal layer is disposed between the first and second substrates.

[0019] In another exemplary embodiment of the present invention, an LCD apparatus is provided. The LCD apparatus has a reflective region and a transmissive region. The LCD apparatus includes a lower substrate, an upper substrate and a liquid crystal layer. The lower substrate includes a substrate, a switching device, an insulation layer, a reflective plate, a planarization layer, a transparent electrode layer and an inner polarization layer. The switching device is formed on the substrate and includes a gate electrode, a source electrode and a drain electrode. The insulation layer is formed on the substrate to cover the switching device. The insulation layer has a contact hole that exposes a portion of the drain electrode of the switching device. The reflective plate is formed on the insulation layer of the reflective region such that the reflective plate is electrically connected to the drain electrode through the contact hole. The planarization layer is formed on the reflective plate of the reflective region, and the insulation layer of the transmissive region. The transparent electrode layer is formed on the planarization layer such that the transparent electrode is electrically

connected to the drain electrode. The inner polarization layer is formed on the transparent electrode layer of the reflective region to cover the reflective plate. The upper substrate faces the lower substrate. The liquid crystal layer is disposed between the lower and upper substrate such that the liquid crystal layer. The liquid crystal layer has a uniform cell gap throughout the reflective and transmissive regions.

[0020] In still another exemplary embodiment of the present invention, an LCD apparatus is provided. The LCD apparatus includes a lower substrate, an upper substrate and a liquid crystal layer. The lower substrate includes a first transparent substrate, a switching device, a transparent electrode layer, a reflective plate, a planarization layer and an inner polarization layer. The switching device is formed on the first transparent substrate. The switching device has a gate electrode, a source electrode and a drain electrode. The transparent electrode layer is electrically connected to the drain electrode of the switching device. The reflective plate is electrically connected to the drain electrode of the switching device and has flexuous surface. The planarization layer is formed on the reflective plate and has a flat surface. The inner polarization layer is formed on the planarization layer. The upper substrate is combined with the lower substrate. The liquid crystal layer is disposed between the lower and upper substrates.

[0021] In still another exemplary embodiment of the present invention, an LCD apparatus is provided. The LCD apparatus includes a first substrate, an upper polarization plate, a second substrate, a lower polarization plate and a liquid crystal layer. The upper polarization plate is disposed on an upper surface of the first substrate. The upper polarization plate transmits a light having a first polarization axis. The second substrate is combined with the first substrate including a reflective plate and an inner polarization layer that is disposed on the reflective plate and has a second polarization axis that is substantially perpendicular to the first polarization axis. The lower polarization plate is disposed on a lower surface of the second substrate. The lower polarization plate transmits a light having the second polarization. The liquid crystal layer is disposed between the first and second substrates. The liquid crystal layer rotates a polarization axis of a light, when the light passes through the liquid crystal layer.

BRIEF DESCRIPTION OF THE DRAWINGS

[0022] FIG. 1 is a cross-sectional view illustrating a liquid crystal display (LCD) apparatus having a single cell gap structure according to an exemplary embodiment of the present invention;

[0023] FIGS. 2A and 2B are conceptual views illustrating a light path of the LCD apparatus in FIG. 1;

[0024] FIGS. 3A through 3G are cross-sectional views illustrating a method of manufacturing the LCD apparatus in FIG. 1;

[0025] FIG. 4 is a cross-sectional view illustrating an LCD apparatus having a signal gap structure according to an exemplary embodiment of the present invention;

[0026] FIGS. 5A and 5B are conceptual views illustrating a light path of the LCD apparatus in FIG. 4;

[0027] FIG. 6 is a cross-sectional view illustrating an LCD apparatus having a signal gap structure according to an exemplary embodiment of the present invention;

[0028] FIGS. 7A through 7G are cross-sectional views illustrating a method of manufacturing the LCD apparatus in FIG. 6;

[0029] FIG. 8 is a cross-sectional view illustrating an LCD apparatus having a signal gap structure according to an exemplary embodiment of the present invention;

[0030] FIG. 9 is a cross-sectional view illustrating an LCD apparatus according to an exemplary embodiment of the present invention;

[0031] FIGS. 10A and 10B are conceptual views illustrating a light path of the LCD apparatus in FIG. 9;

[0032] FIGS. 11A through 11J are cross-sectional views illustrating a method of manufacturing the LCD apparatus in FIG. 9;

[0033] FIG. 12 is a cross-sectional view illustrating an LCD apparatus according to an exemplary embodiment of the present invention;

[0034] FIGS. 13A and 13B are conceptual views illustrating a light path of the LCD apparatus in FIG. 12;

[0035] FIG. 14 is a cross-sectional view illustrating an LCD apparatus according to an exemplary embodiment of the present invention;

[0036] FIGS. 15A and 15B are conceptual views illustrating a light path of the LCD apparatus in FIG. 14;

[0037] FIG. 16 is a cross-sectional view illustrating an LCD apparatus according to an exemplary embodiment of the present invention; and

[0038] FIGS. 17A and 17B are conceptual views illustrating a light path of the LCD apparatus in FIG. 16.

DESCRIPTION OF THE EXEMPLARY EMBODIMENTS

[0039] It should be understood that the exemplary embodiments of the present invention described below may be varied modified in many different ways without departing from the inventive principles disclosed herein, and the scope of the present invention is therefore not limited to these particular flowing embodiments.

[0040] Hereinafter, the embodiments of the present invention will be described in detail with reference to the accompanied drawings. It is noted that various changes, substitutions and alterations can be made herein without departing from the spirit and scope of the invention as defined by embodiments that will be described below. The embodiments are only examples for showing the spirit of the present invention to a person skilled in the art. In the figures, a thickness of layers is exaggerated for clarity. The term "disposed on" means "disposed over". In other words, something may be disposed therebetween. The term "disposed directly on" means that nothing is disposed therebetween.

[0041] FIG. 1 is a cross-sectional view illustrating a liquid crystal display (LCD) apparatus having a single cell gap structure according to an exemplary embodiment of the present invention.

[0042] Referring to FIG. 1, the liquid crystal display (LCD) panel includes an array substrate 100, a liquid crystal

layer 200, a color filter substrate 300, a first polarization plate 410 and a second polarization plate 420. The array substrate 100 and the color filter substrate 300 are combined with each other. The liquid crystal layer 200 is disposed between the array substrate 100 and the color filter substrate 300. The first polarization plate 410 is disposed on a lower face of the array substrate 100, and the second polarization plate 420 is disposed on an upper face of the color filter substrate 300. The first and second polarization plates 410 and 420 have different polarization axis from each other. For example, a polarization axis of the first polarization plate 410 is substantially perpendicular to a polarization axis of the second polarization plate 420.

[0043] The array substrate 100 includes a first transparent substrate 105, a gate electrode 112 and a gate insulation layer 114. The gate electrode 112 is formed on the first transparent substrate 105. The gate electrode 112 is protruded from a gate line. The gate insulation layer 114 includes, for example silicon nitride (SiNx). The gate insulation layer 114 is formed on the first transparent substrate 105 having the gate electrode 112 to cover the gate electrode 112. The gate line and the gate electrode 112 include but are not limited to a metal or a metal alloy such as aluminum (Al), aluminum alloy, silver (Ag), silver alloy, copper (Cu), copper alloy, molybdenum (Mo), molybdenum alloy, chromium (Cr), tantalum (Ta), titanium (Ti), etc.

[0044] The array substrate 100 further includes a semiconductor layer 116, an ohmic contact layer 118, a source electrode 120 and a drain electrode 122. The semiconductor layer 116 includes, for example amorphous silicon (a-Si), and the ohmic contact layer 118 includes, for example n-doped amorphous silicon (a-Si). The source electrode 120 covers a first portion of the ohmic contact layer 118, and the drain electrode 122 covers a second portion of the ohmic contact layer 118. The source and drain electrodes 120 and 122 are spaced apart from each other. The gate electrode 112, the semiconductor layer 116, the ohmic contact layer 118, the source electrode 120 and the drain electrode 122 form a thin film transistor (TFT). The source and drain electrodes 120 and 122 may include but are not limited to a metal or a metal alloy such as aluminum (Al), aluminum alloy, silver (Ag), silver alloy, copper (Cu), copper alloy, molybdenum (Mo), molybdenum alloy, chromium (Cr), tantalum (Ta), titanium (Ti), etc.

[0045] The gate, source and drain electrodes 112, 120 and 122 have, for example a single layered structure. Alternatively, one of the gate, source and drain electrodes 112, 120 and 122 may have a multi-layered structure. When the gate, source and drain electrodes 112, 120 and 122 have a single layered structure, the gate, source and drain electrodes 112, 120 and 122 may include but are not limited to a metal or a metal alloy such as aluminum (Al), aluminum neodymium (AlNd), copper (Cu), etc. When the gate, source and drain electrodes 112, 120 and 122 have, for example a double layered structure including a lower layer and an upper layer, the lower layer include but are not limited to a metal such as chromium (Cr), molybdenum (Mo), molybdenum alloy, etc., and the upper layer includes a metal or a metal alloy such as aluminum, aluminum alloy, etc.

[0046] The array substrate 100 further includes a passivation layer 130 and a pixel electrode layer 140. The passivation layer 130 includes a contact hole that exposes a portion of the drain electrode 122. The pixel electrode layer 140 is formed on the passivation layer 130. The pixel electrode layer 140 is electrically connected to the drain electrode 122 through the contact hole. The passivation layer 130 protects the semiconductor layer 116 and the ohmic contact layer 118 disposed between the source and drain electrodes 120 and 122. The pixel electrode layer 140 is disposed at both of a reflective region RA and a transmissive region TA.

[0047] The array substrate 100 further includes an organic insulation layer 160, a reflective plate 170, a planarization layer 180, an inner polarization layer 190 and a first alignment layer 199. The organic insulation layer 160 covers the pixel electrode layer 140. The organic insulation layer 160 includes a via-hole that exposes a portion of the pixel electrode layer 140. The via-hole is disposed over the contact hole. The organic insulation layer 160 has embossing patterns. The embossing patterns are formed on an upper surface of the organic insulation layer 160. The reflective plate 170 is formed at the reflective region RA. The reflective plate 170 is electrically connected to the pixel electrode through the via-hole. The planarization layer 180 is formed on the reflective plate 170. The inner polarization layer 190 is formed on the planarization layer 180. The first alignment layer 199 is formed on the inner polarization layer 190. The inner polarization layer 190 and the first polarization plate 410 have substantially parallel polarization axis.

[0048] Preferably, the planarization layer 180 has a relatively thinner thickness as long as the planarization layer 180 levels the embossing patterns. For example, when the embossing patterns have a height of about 0.5 μm , the planarization layer 180 has a thickness of about 0.5 μm .

[0049] The color filter substrate 300 includes a second transparent substrate 305, a light blocking layer 310, a color filter layer 320, an over coating layer 330, a common electrode layer 340 and a second alignment layer 350. The light blocking layer 310 is formed on the second transparent substrate 305. The light blocking layer 310 includes a plurality of openings arranged in a matrix shape. Each of the openings defines a pixel. The color filter layer 320 is formed on the second transparent substrate 305 exposed through the openings of the light blocking layer 310. The over coating layer 330 is formed on the color filter layer 320. The common electrode layer 330 is formed on the over coating layer 330. The second alignment layer 350 is formed on the common electrode layer 330. The color filter substrate 300 is combined with the array substrate 100 such that the liquid crystal layer 200 is disposed between the color filter substrate 300 and the array substrate 100.

[0050] Thin crystal film (TCF®) of Optiva Inc. in U.S.A may be employed as the inner polarization layer 190. The thin crystal film includes dyestuff of a chromogen base.

[0051] Optical characteristics of the thin crystal film are described in the following Table 1.

TABLE 1

Optical characteristics of samples					
Transparency (%)	H90 (%)	H0 (%)	Efficiency (%)	Contrast ratio	TCF thickness (μm)
44.95	5.26	35.15	86.00	6.68	0.3
44.53	5.08	34.57	86.25	6.81	0.3
43.89	4.93	33.59	86.25	6.81	0.3
43.73	4.55	33.70	87.29	7.40	0.3
33.72	0.18	33.56	99.20	124.01	0.4
34.22	0.11	23.31	99.54	215.46	0.6
34.20	0.12	23.23	99.50	201.30	0.6
33.65	0.10	22.54	99.55	219.46	0.6

[0052] In Table 1, 'H0' represents a 'parallel transmittance' that corresponds to a transmittance when the polarizing axes of the first and second polarizing plates 410 and 420 are substantially parallel with each other, and 'H90' represents a 'perpendicular transmittance' that corresponds to a transmittance when the polarizing axes of the first and second polarizing plates 410 and 420 are substantially perpendicular to each other. Hereinafter, both of the parallel transmittance and the perpendicular transmittance are referred to as 'polarization transmittance'.

[0053] Referring to Table 1, the polarization transmittance, the contrast ratio is changed when the thickness of thin crystal film is changed. In detail, when the thickness of thin crystal film increases, the polarization transmittance decreases and the contrast ratio increases.

[0054] The thin crystal film according to the exemplary embodiments of the present invention having above described optical characteristics may be employed by a transmissive LCD apparatus for enhancing the display quality of the transmissive LCD apparatus. A transmissive LCD apparatus includes both the reflective plate and transmissive window. It is noted that the polarization transmittance is a more important factor than the contrast ratio in a reflective mode. However, the contrast ratio is a more important factor than the polarization transmittance in a transmissive mode. By using a thin crystal film according to exemplary embodiments of the invention, a transmissive LCD apparatus having a relatively high transmittance at the reflective region RA and a relatively high contrast ratio at the transmissive region is provided, thereby enhancing the display quality of the LCD apparatus.

[0055] The thin crystal film corresponds to a polymer resin that is a gel type and has a viscosity of about 300 psi. Thus, the thin crystal film may be formed, for example by slot die coating method.

[0056] Hereinafter, a transmissive mode operation and a reflective mode operation of the transmissive LCD apparatus according to the present exemplary embodiment will be explained. For example, the transmissive LCD apparatus that will be explained displays white color when no electric fields are applied to the liquid crystal layer 200. In other words, the transmissive LCD apparatus corresponds to a normally white mode. The transmissive LCD apparatus includes a first polarization plate 410 that has a first polarization axis, an inner polarization layer 190 that has a polarization axis that is substantially parallel with the first

polarization axis, and a second polarization plate **420** having a second polarization axis that is substantially perpendicular to the first polarization axis.

[0057] **FIGS. 2A and 2B** are conceptual views illustrating a light path of the LCD apparatus in **FIG. 1**. Hereinafter, a 'first axis' is defined as an axis that is disposed on a paper of drawings, and a 'second axis' is defined as an axis that is substantially parallel with a normal line of the paper.

[0058] Reflective Mode Operation

[0059] **FIG. 2A** corresponds to the reflective mode of the transfective LCD apparatus in **FIG. 1**.

[0060] Referring to **FIG. 2A**, when external light advances toward the second polarization plate **420**, a portion of that light oscillates along the first axis and passes through the second polarization plate **420**, and the remaining portion of the light is blocked by the second polarization plate **420**. If no electric fields are applied to the liquid crystal layer **200** (Eoff), a portion of the light passes through the liquid crystal layer **200** and is rotated to oscillate along the second axis. The portion of the light which oscillates along the second axis, passes through the inner polarization layer **190** because the inner polarization layer **190** has a polarization axis that is substantially perpendicular to a polarization axis of the second polarization plate **420**, and thus this portion of the light is reflected by the reflective plate **170** and passes through the inner polarization layer **190**. The portion of the light that exits from the inner polarization layer **190** enters the liquid crystal layer **200**. When the portion of the light exits from the liquid crystal layer **200**, this portion of the light is rotated by the liquid crystal layer **200** to pass through the second polarization plate **420**, thereby resulting in white color being displayed.

[0061] When electric fields are applied to the liquid crystal layer **200** (Eon), the arrangement of liquid crystal molecules in the liquid crystal layer **200** is changed, so that the portion of light that passes through the second polarization plate **420** passes through the liquid crystal layer **200** without being rotated. As a result, the portion of light that passes through the liquid crystal layer **200** without being rotated is blocked by the inner polarization layer **190**, so that the reflective plate **170** does not reflect light, thereby resulting in a black color being displayed.

[0062] Transmissive Mode Operation

[0063] **FIG. 2B** corresponds to the transmissive mode of the transfective LCD apparatus in **FIG. 1**.

[0064] Referring to **FIG. 2B**, light generated from a backlight assembly advances toward the first polarization plate **410**. A portion of that light oscillates along the second axis and passes through the first polarization plate **410**, and the remaining portion of the light is blocked by the first polarization plate **410**. If no electric fields are applied to the liquid crystal layer **200** (Eoff), a portion of the light passes through the liquid crystal layer **200** and is rotated to oscillate along the first axis. The portion of the light that oscillates along the first axis passes through the second polarization plate **420**, because the second polarization plate **420** has a polarization axis that is substantially perpendicular to a polarization axis of the first polarization plate **410**, thereby also resulting in white color being displayed.

[0065] When electric fields are applied to the liquid crystal layer **200** (Eon), the arrangement of liquid crystal molecules in the liquid crystal layer **200** is changed, so that the portion of light that passes through the first polarization plate **410** passes through the liquid crystal layer **200** without being rotated. As a result, the portion of light that passes through the liquid crystal layer **200** without being rotated is blocked by the second polarization plate **420**, so only black color is displayed.

[0066] **FIGS. 3A through 3G** are cross-sectional views illustrating a method of manufacturing the LCD apparatus in **FIG. 1**.

[0067] Referring to **FIG. 3A**, a metal layer including but not limited to a metal such as tantalum (Ta), titanium (Ti), molybdenum (Mo), aluminum (Al), chromium (Cr), copper (Cu), tungsten (W), etc. is formed on the first transparent substrate **105** including glass, ceramic, etc.

[0068] The metal layer is patterned to form a plurality of gate lines and a gate electrode **112** protruded from the gate line.

[0069] The gate insulation layer **114** including, for example silicon nitride is formed on the first transparent substrate **105** having the gate lines and the gate electrode **112** to cover the gate lines and the gate electrode **112**. The gate insulation layer **114** may be formed on all portions of an upper surface of the first transparent substrate **105**. Alternatively, the gate insulation layer **114** may be formed on only portions of the upper surface of the first transparent substrate **105** such that the gate insulation layer **114** covers the gate line and the gate electrode **112**.

[0070] An amorphous silicon (a-Si) layer is formed on the gate insulation layer **114** and n+ amorphous silicon (n+ a-Si) layer is formed on the amorphous silicon layer. Further, the amorphous silicon layer and the n+ amorphous silicon layer are patterned to form the semiconductor layer **116** and the ohmic contact layer **118** of the thin film transistor.

[0071] A metal layer including but not limited to a metal such as tantalum (Ta), titanium (Ti), molybdenum (Mo), aluminum (Al), chromium (Cr), copper (Cu), tungsten (W), etc. is formed on the first transparent substrate **105** having the semiconductor layer **116** and the ohmic contact layer **118**. The metal layer is patterned to form the plurality of source lines, the source electrode **120** which protrudes from the source lines, and the drain electrode **122** which is spaced apart from the source electrode **120**.

[0072] Referring to **FIG. 3B**, the passivation layer **130** is formed on the first transparent substrate **105** having the plurality of source lines, the source electrode **120** and the drain electrode **122**, by way of, e.g., a spin coating method. Other methods known in the art for forming the passivation layer **130** may also be used. A portion of the passivation layer **130** is removed to form the contact hole CNT that exposes a portion of the drain electrode **122**. Then, the pixel electrode layer **140** is formed on the passivation layer **130**. The pixel electrode layer **140** is electrically connected to the drain electrode **122** through the contact hole CNT. The pixel electrode layer **140** includes an optically transparent and electrically conductive material such as indium tin oxide (ITO), indium zinc oxide (IZO), zinc oxide (ZO), etc. The pixel electrode layer **140** may be formed on a portion of an upper surface of the passivation layer **130**, which corre-

sponds to pixel region. Alternatively, the pixel electrode layer **140** may be formed on all portions of the upper surface of the passivation layer **130**, and the pixel electrode layer **140** may be patterned. A primitive organic insulation layer **160-b** is formed on the pixel electrode layer **140**.

[0073] Referring to **FIG. 3C**, embossing patterns and via-hole that exposes the pixel electrode layer **140** are formed on an upper surface of the primitive organic insulation layer **160-b** to form the organic insulation layer **160**. For example, a photo mask having patterns that correspond to the embossing patterns is disposed over the primitive organic insulation layer **160-b**, and the primitive organic insulation layer **160-b** is exposed and developed to form the organic insulation layer having the embossing patterns and the via-hole.

[0074] Referring to **FIG. 3D**, a metal layer including but not limited to a metal or metal alloy such as aluminum (Al), silver (Ag), aluminum neodymium (AlNd), etc. is formed on the organic insulation layer **160** having the embossing patterns, and the metal layer is patterned to form the reflective plate **170**. The reflective plate **170** has a relatively thin thickness, so that the reflective plate **170** has the same or at least substantially the same surface shape as that of the organic insulation layer **160**. In other words, the reflective plate **170** also includes embossing patterns. As a result, the reflective plate **170** resembles a plurality of convex mirrors and a plurality of concave mirrors.

[0075] Referring to **FIG. 3E**, a planarization layer **180** that is optically transparent is formed on the organic insulation layer **160** having the reflective plate **170**. The planarization layer **180** levels the surface of the reflective plate **170** corresponding to the reflective region and the insulation layer **160** corresponding to the transmissive region. Portions of the planarization layer **180**, which correspond to a data pad that corresponds to an end portion of the data line, and a gate pad that corresponds to an end portion of the gate line, are each preferably removed to expose the data pad and the gate pad.

[0076] Referring to **FIG. 3F**, the inner polarization layer **190** is formed on the planarization layer **180**. By way of example, a disc type liquid crystal layer is formed on the planarization layer **180**, through a slit coating method, wherein a shear stress is applied along a desired polarization axis. The disc type liquid crystal layer is pre-cured, and a portion of the disc type liquid crystal layer, which corresponds to the transmissive region is removed through a wet-etching process or dry etching process. As a result, the disc type liquid crystal layer is disposed only at the reflective region. The disc type liquid crystal layer corresponds to the inner polarization layer **190**.

[0077] Referring to **FIG. 3G**, the first alignment layer **199** is formed on the planarization layer **180** and the inner polarization layer **190** through a polyimide printing method. The first alignment layer **199** undergoes a rubbing process. When rubbing is non-uniform, the display quality of the LCD apparatus is deteriorated. Macroscopic characteristics of the liquid crystal layer is dependant on an arrangement of the liquid crystal molecules of the liquid crystal layer, and the first alignment layer **199** applies a boundary condition to the liquid crystal molecules that makes contact with the first alignment layer **199**. When an LCD apparatus employs twisted nematic (TN) liquid crystal mode, a polyimide layer

is preferably employed as the first alignment layer **199**. Polyimide acid or polyimide solution of about 4% by weight to about 8% by weight may be used for the polyimide solution.

[0078] The first alignment layer **199** has a thickness of about 500 angstroms to about 1000 angstroms. When a thickness variation of the first alignment layer **199** exceeds 100 angstroms, the display quality of the LCD apparatus is reduced. Therefore, the thickness variation of the first alignment layer **199** should be adjusted to be less than about 100 angstroms.

[0079] To adjust the thickness variation of the first alignment layer **199**, a pre-curing process is performed. In situations where the drying speed of the solvent is high, the polyimide solution is first hardened before the polyimide solution is uniformly diffused. When the pre-curing process is completed, a hard-curing process is then performed.

[0080] **FIG. 4** is a cross-sectional view illustrating an LCD apparatus having a signal gap structure according to an exemplary embodiment of the present invention.

[0081] Referring to **FIG. 4**, the liquid crystal display (LCD) panel includes an array substrate **500**, a liquid crystal layer **200**, a color filter substrate **300**, a first polarization plate **410** and a second polarization plate **420**. The array substrate **500** and the color filter substrate **300** are combined with each other. The liquid crystal layer **200** is disposed between the array substrate **500** and the color filter substrate **300**. The first polarization plate **410** is disposed on a lower face of the array substrate **500**, and the second polarization plate **420** is disposed on an upper face of the color filter substrate **200**. The first and second polarization plates **410** and **420** have different polarization axis from each other. For example, a polarization axis of the first polarization plate **410** is substantially perpendicular to a polarization axis of the second polarization plate **420**. The LCD panel of the present exemplary embodiment is same as the previous exemplary embodiment depicted in **FIGS. 1-3G** except for the array substrate **500**. Thus, the same reference numerals will be used to refer to the same or like parts as those described in the previous exemplary embodiment of **FIGS. 1-3G** and any further explanation concerning the above elements will be omitted.

[0082] The array substrate **500** includes an organic insulation layer **160**, a reflective plate **570**, an inner polarization layer **580** and a first alignment layer **590**. The organic insulation layer **160** covers the pixel electrode layer **140**. A plurality of embossing patterns are formed on an upper surface of the organic insulation layer **160**. The reflective plate **570** is formed on the organic insulation layer **160**. The reflective plate **570** is disposed at the reflective region RA. The inner polarization layer **580** is formed on the reflective plate **570**. The first alignment layer **590** is formed on the reflective plate **570** and the organic insulation layer **160**. A polarization axis of the inner polarization layer **580** is substantially parallel with a polarization layer of the first polarization plate **410**.

[0083] **FIGS. 5A and 5B** are conceptual views illustrating a light path of the LCD apparatus in **FIG. 4**. Hereinafter, a 'first axis' is defined as an axis that is disposed on a paper of drawings, and a 'second axis' is defined as an axis that is substantially parallel with a normal line of the paper.

[0084] Reflective Mode Operation

[0085] FIG. 5A corresponds to the reflective mode of the transfective LCD apparatus in FIG. 4.

[0086] Referring to FIG. 5A, when external light advances toward the second polarization plate 420, a portion of that light oscillates along the first axis and passes through the second polarization plate 420, and the remaining portion of the light is blocked by the second polarization plate 420. If no electric fields are applied to the liquid crystal layer 200 (Eoff), a portion of the light passes through the liquid crystal layer 200 and is rotated to oscillate along the second axis. The portion of light that oscillates along the second axis passes through the inner polarization layer 580, because the inner polarization layer 580 has a polarization axis that is substantially perpendicular to a polarization axis of the second polarization plate 420, so that the portion of the light is reflected by the reflective plate 170 and passes through the inner polarization layer 580. The portion of the light that exits from the inner polarization layer 580 enters the liquid crystal layer 200. When the portion of the light that exits from the liquid crystal layer 200, this portion of the light is rotated by the liquid crystal layer 200 to pass through the second polarization plate 420, thereby resulting in white color being displayed.

[0087] When electric fields are applied to the liquid crystal layer 200 (Eon), the arrangement of liquid crystal molecules in the liquid crystal layer 200 is changed, so that the portion of light that passes through the second polarization plate 420 passes through the liquid crystal layer 200 without being rotated. Thus, the portion of light that passes through the liquid crystal layer 200 without being rotated is blocked by the inner polarization layer 580, so that the reflective plate 570 does not reflect light, thereby resulting in black color being displayed.

[0088] Transmissive Mode Operation

[0089] FIG. 5B corresponds to the transmissive mode of the transfective LCD apparatus in FIG. 4.

[0090] Referring to FIG. 5B, light generated from a backlight assembly advances toward the first polarization plate 410. A portion of that light oscillates along the second axis and passes through the first polarization plate 410. The remaining portion of the light is blocked by the first polarization plate 410. If no electric fields are applied to the liquid crystal layer 200 (Eoff), a portion of the light passes through the liquid crystal layer 200 and is rotated to oscillate along the first axis. The portion of the light that oscillates along the first axis passes through the second polarization plate 420, because the second polarization plate 420 has a polarization axis that is substantially perpendicular to a polarization axis of the first polarization plate 410, thereby also causing white color to be displayed.

[0091] When electric fields are applied to the liquid crystal layer 200 (Eon), the arrangement of liquid crystal molecules in the liquid crystal layer 200 is changed, so that the portion of light that passes through the first polarization plate 410 passes through the liquid crystal layer 200 without being rotated. As a result, the portion of light that passes through the liquid crystal layer 200 without being rotated is blocked by the second polarization plate 420, and thus black color is displayed.

[0092] FIG. 6 is a cross-sectional view illustrating an LCD apparatus having a signal gap structure according to an exemplary embodiment of the present invention.

[0093] Referring to FIG. 6, a liquid crystal display (LCD) panel includes an array substrate 600, a liquid crystal layer 200, a color filter substrate 300, a first polarization plate 410 and a second polarization plate 420. The array substrate 600 and the color filter substrate 300 are combined with each other. The liquid crystal layer 200 is disposed between the array substrate 600 and the color filter substrate 300. The first polarization plate 410 is disposed on a lower face of the array substrate 600, and the second polarization plate 420 is disposed on an upper face of the color filter substrate 300. The first and second polarization plates 410 and 420 have a different polarization axis from each other. For example, a polarization axis of the first polarization plate 410 is substantially perpendicular to a polarization axis of the second polarization plate 420. The LCD panel of the present embodiment is same as the previous exemplary embodiment depicted in FIGS. 1-3G except for the array substrate 500. Thus, the same reference numerals will be used to refer to the same or like parts as those described in the exemplary embodiment depicted in FIGS. 1-3G and any further explanation concerning the above elements will be omitted.

[0094] The array substrate 600 includes a passivation layer 130, an organic insulation layer 640, a pixel electrode layer 650, a reflective plate 660, an inner polarization layer 670 and a first alignment layer 680.

[0095] The passivation layer 130 covers the thin film transistor TFT. The passivation layer 130 includes a contact hole that exposes a portion of the drain electrode 122 of the thin film transistor TFT. The passivation layer 130 protects the semiconductor layer 116 and the ohmic contact layer 118 disposed between the source and drain electrodes 120 and 122.

[0096] The organic insulation layer 640 is formed on the passivation layer 130. The organic insulation layer 640 has embossing patterns. The embossing patterns are formed on an upper surface of the organic insulation layer 640. The organic insulation layer 640 includes a connection hole CNT that exposes a portion of the drain electrode 122 of the thin film transistor TFT.

[0097] The pixel electrode layer 650 is formed on the organic insulation layer 640. The pixel electrode layer 650 is electrically connected to the drain electrode 122 of the thin film transistor TFT through the connection hole CNT. The pixel electrode layer 650 includes an optically transparent and electrically conductive material such as indium tin oxide (ITO), indium zinc oxide (IZO), zinc oxide (ZO), etc.

[0098] The reflective plate 660 is formed on the pixel electrode layer 650. The reflective plate 660 is disposed at the reflective region RA. The inner polarization layer 670 is formed on the reflective plate 660. The first alignment layer 680 is formed on the inner polarization layer 670 and the pixel electrode layer 650. A polarization axis of the inner polarization layer 670 is substantially parallel with a polarization layer of the first polarization plate 410.

[0099] The color filter substrate 300 includes a second transparent substrate 305, a light blocking layer 310, a color filter layer 320, an over coating layer 330, a common electrode layer 340 and a second alignment layer 350. The

light blocking layer **310** is formed on the second transparent substrate **305**. The light blocking layer **310** includes a plurality of openings arranged in a matrix shape. Each of the openings defines a pixel. The color filter layer **320** is formed on the second transparent substrate **305** exposed through the openings of the light blocking layer **310**. The over coating layer **330** is formed on the color filter layer **320**. The common electrode layer **330** is formed on the over coating layer **330**. The second alignment layer **350** is formed on the common electrode layer **330**. The color filter substrate **300** is combined with the array substrate **100** such that the liquid crystal layer **200** is disposed between the color filter substrate **300** and the array substrate **100**.

[0100] FIGS. 7A through 7G are cross-sectional views illustrating a method of manufacturing the LCD apparatus in FIG. 6.

[0101] Referring to FIG. 7A, a metal layer including but not limited to a metal such as tantalum (Ta), titanium (Ti), molybdenum (Mo), aluminum (Al), chromium (Cr), copper (Cu), tungsten (W), etc. is formed on the first transparent substrate **605** including glass, ceramic, etc.

[0102] The metal layer is patterned to form a plurality of gate lines and a gate electrode **112** protruded from the gate line.

[0103] The gate insulation layer **114** including, for example silicon nitride is formed on the first transparent substrate **105** having the gate lines and the gate electrode **112** to cover the gate lines and the gate electrode **112**. The gate insulation layer **114** may be formed on all portions of an upper surface of the first transparent substrate **105**. Alternatively, the gate insulation layer **114** may be formed on only portions of the upper surface of the first transparent substrate **105** such that the gate insulation layer **114** covers the gate line and the gate electrode **112**.

[0104] An amorphous silicon (a-Si) layer is formed on the gate insulation layer **114** and n+ amorphous silicon (n+ a-Si) layer is formed on the amorphous silicon layer. The amorphous silicon layer and the n+ amorphous silicon layer are patterned to form the semiconductor layer **116** and the ohmic contact layer **118** of the thin film transistor, respectively.

[0105] A metal layer including but not limited to a metal such as tantalum (Ta), titanium (Ti), molybdenum (Mo), aluminum (Al), chromium (Cr), copper (Cu), tungsten (W), etc. is formed on the first transparent substrate **105** having the semiconductor layer **116** and the ohmic contact layer **118**. The metal layer is patterned to form the plurality of source lines, the source electrode **120** protruding from the source lines, and the drain electrode **122** which is spaced apart from the source electrode **120**.

[0106] Referring to FIG. 7B, the passivation layer **130** is formed on the first transparent substrate **105** having the plurality of source lines, the source electrode **120** and the drain electrode **122**, such as by way of, e.g. a spin coating method. A first primitive organic insulation layer **640-b** is formed on the passivation layer **130**.

[0107] Referring to FIG. 7C, a portion of the first primitive organic insulation layer **640-b** is removed to form a primitive connection hole that exposes a portion of the passivation layer **130**, and embossing patterns are formed on an upper surface of the first primitive organic insulation

layer **640-b** to form a second primitive organic insulation layer **640-c**. For example, a photo mask MA having a transparent base substrate MA1 and opaque patterns MA2 are disposed over the first primitive organic insulation layer **640-b**. The opaque patterns MA2 are formed on the transparent base substrate MA1. The first primitive organic insulation layer **640-b** is exposed and developed to form primitive embossing patterns, so that the second primitive organic insulation layer **640-c** is completed.

[0108] Referring to FIG. 7D, the portion of the passivation layer **130** is removed to form the connection hole CNT that exposes a portion of the drain electrode **122**. Then, a reflow-process is performed to smoothen a surface of the primitive embossing patterns of the second organic insulation layer **640-c**, so that the embossing patterns of the organic insulation layer **640** are formed.

[0109] Referring to FIG. 7E, the pixel electrode layer **650** is formed on the organic insulation layer **640**. The pixel electrode layer **650** is electrically connected to the drain electrode **122** through the contact hole CNT. The pixel electrode layer **650** includes an optically transparent and electrically conductive material such as indium tin oxide (ITO), indium zinc oxide (IZO), zinc oxide (ZO), etc. The pixel electrode layer **650** may be formed on a portion of an upper surface of the organic insulation layer **640**, which corresponds to pixel region. Alternatively, the pixel electrode layer **650** is formed on all portions of the upper surface of the organic insulation layer **640**, and the pixel electrode layer **650** may be patterned.

[0110] A metal layer including but not limited to a metal or a metal alloy such as aluminum (Al), silver (Ag), aluminum neodymium (AlNd), etc. are formed on the pixel electrode layer **650**, and the metal layer is patterned to form the reflective plate **660**. The reflective plate **660** has a relatively thin thickness, so that the reflective plate **660** has the same or at least substantially the same surface shape as that of the pixel electrode layer **650** and the organic insulation layer **640**. In other words, the reflective plate **660** also includes embossing patterns. As a result, the reflective plate **660** resembles a plurality of convex mirrors and a plurality of concave mirrors.

[0111] Referring to FIGS. 7F and 7G, a primitive inner polarization layer **670-b** is formed on the reflective plate **660** and the pixel electrode layer **650**. For example, a disc type liquid crystal layer that corresponds to the primitive inner polarization layer **670-b** is formed on reflective plate **660** and the pixel electrode layer **650**, for example through a slit coating method, wherein a shear stress is applied along a desired polarization axis. The disc type liquid crystal layer is pre-cured, and a portion of the disc type liquid crystal layer, which corresponds to the transmissive region, is removed, for example through a wet-etching process or dry etching process. In addition, a mask MA having a transparent base substrate MA1 with an opaque pattern MA2 is disposed over the primitive inner polarization layer **670-b**. For example, the opaque pattern MA2 corresponds to a reflective region. Then, the disc type liquid crystal layer is exposed and developed, and a portion of the disc type liquid crystal layer, which corresponds to the transmissive region, is removed to form the inner polarization layer **670** in the reflective region.

[0112] Referring to FIG. 7G, the first alignment layer **680** is formed on the inner polarization layer **670** of the reflective

region and the pixel electrode layer 650 of the transmissive region, for example through a polyimide printing process.

[0113] FIG. 8 is a cross-sectional view illustrating an LCD apparatus having a signal gap structure according to an exemplary embodiment of the present invention.

[0114] Referring to FIG. 8, a liquid crystal display (LCD) panel includes an array substrate 700, a liquid crystal layer 200, a color filter substrate 300, a first polarization plate 410 and a second polarization plate 420. The array substrate 700 and the color filter substrate 300 are combined with each other. The liquid crystal layer 200 is disposed between the array substrate 700 and the color filter substrate 300. The first polarization plate 410 is disposed on a lower face of the array substrate 700, and the second polarization plate 420 is disposed on an upper face of the color filter substrate 200. The first and second polarization plates 410 and 420 have different polarization axis from each other. For example, a polarization axis of the first polarization plate 410 is substantially perpendicular to a polarization axis of the second polarization plate 420. The LCD panel of the present embodiment is same as the exemplary embodiment depicted in FIG. 6 except for a planarization layer 770 and an inner polarization layer 780. Thus, the same reference numerals will be used to refer to the same or like parts as those described in the exemplary embodiment depicted in FIG. 6 and any further explanation concerning the above elements will be omitted.

[0115] The array substrate 700 includes the planarization layer 770, the inner polarization layer 780 and the first alignment layer 790. The planarization layer 770 is formed on the reflective plate 660 having embossing patterns. The inner polarization layer 780 is formed on the planarization layer 770. The first alignment layer 790 is formed on the inner polarization layer 780. The reflective plate 660, the planarization layer 770, the inner polarization layer 780 are disposed at the reflective region RA. The inner polarization layer 780 and the first polarization plate 410 have substantially parallel polarization axis. The first alignment layer 790 is formed on the inner polarization layer 780 of the reflective region RA and the pixel electrode layer 650 of the transmissive region TA.

[0116] FIG. 9 is a cross-sectional view illustrating an LCD apparatus according to an exemplary embodiment of the present invention.

[0117] Referring to FIG. 9, the LCD panel includes an array substrate 800, a liquid crystal layer 200, a color filter substrate 300, a first polarization plate 410 and a second polarization plate 420. The array substrate 800 and the color filter substrate 300 are combined with each other. The liquid crystal layer 200 is disposed between the array substrate 800 and the color filter substrate 300. The first polarization plate 410 is disposed on a lower surface of the array substrate 800, and the second polarization plate 420 is disposed on an upper surface of the color filter substrate 300. The first and second polarization plates 410 and 420 have different polarization axes. For example, the first polarization plate 410 has a polarization axis that is substantially perpendicular to a polarization axis of the second polarization plate 420. The LCD panel of the present exemplary embodiment is same as the exemplary embodiment depicted in FIGS. 1-3G except for the array substrate 800. Thus, the same reference numerals will be used to refer to the same or like parts as those

described in the previous exemplary embodiment depicted in FIGS. 1-3G and any further explanation concerning the above elements will be omitted.

[0118] The array substrate 800 includes a passivation layer 130, an organic insulation layer 840 and a reflective plate 850. The passivation layer 130 covers the thin film transistor TFT. The passivation layer 130 includes a first sub contact hole that exposes a portion of the drain electrode 122 of the thin film transistor TFT. The passivation layer 130 protects a semiconductor layer 116 and the ohmic contact layer 118 disposed between the source electrode 120 and the drain electrode 122.

[0119] The organic insulation layer 840 is disposed on the passivation layer 130. The organic insulation layer 840 includes a second sub contact hole that is connected to the first sub contact hole to expose the portion of the drain electrode 122. The organic insulation layer 840 has embossing patterns.

[0120] The reflective plate 850 is disposed on the organic insulation layer 840, so that the reflective plate 850 has embossing patterns induced by the organic insulation layer 840 to enhance optical reflectivity. The reflective plate 850 is electrically connected to the drain electrode 122 through the first and second contact holes. The reflective plate 850 is disposed at the reflective region RA.

[0121] The array substrate 800 further includes a planarization layer 860, a pixel electrode layer 870, an inner polarization layer 880 and a first alignment layer 890. The planarization layer 860 is formed on the reflective plate 850 of the reflective region RA and the organic insulation layer 840 of the transmissive region TA. The planarization layer 860 includes a third sub contact hole that exposes a portion of the reflective plate 850.

[0122] The pixel electrode layer 870 is formed on the planarization layer 860. The pixel electrode layer 870 is electrically connected to the reflective plate 850 through the third sub contact hole. The pixel electrode layer 870 is disposed at both of the reflective and transmissive regions RA and TA.

[0123] The inner polarization layer 880 is formed on the pixel electrode layer 860 of the reflective region RA, so that the inner polarization layer 880 is disposed over the reflective plate 850. The inner polarization layer 880 has a polarization axis that is substantially parallel with a polarization axis of the first polarization plate 410.

[0124] The color filter substrate 300 includes a second transparent substrate 305, a light blocking layer 310, a color filter layer 320, an over coating layer 330, a common electrode layer 340 and a second alignment layer 350. The light blocking layer 310 is formed on the second transparent substrate 305. The light blocking layer 310 includes a plurality of openings arranged in a matrix type shape. Each of the openings defines a pixel. The color filter layer 320 is formed on the second transparent substrate 305 exposed through the openings of the light blocking layer 310. The over coating layer 330 is formed on the color filter layer 320. The common electrode layer 330 is formed on the over coating layer 330. The second alignment layer 350 is formed on the common electrode layer 330. The color filter substrate 300 is combined with the array substrate 100 such that the

liquid crystal layer **200** is disposed between the color filter substrate **300** and the array substrate **100**.

[0125] **FIGS. 10A and 10B** are conceptual views illustrating a light path of the LCD apparatus in **FIG. 9**. Hereinafter, a 'first axis' is defined as an axis that is disposed on a paper of drawings, and a 'second axis' is defined as an axis that is substantially in parallel with a normal line of the paper.

[0126] Reflective Mode Operation

[0127] **FIG. 10A** corresponds to the reflective mode of the transfective LCD apparatus in **FIG. 9**.

[0128] Referring to **FIG. 10A**, when external light advances toward the second polarization plate **420**, a portion of the light oscillates along the first axis and passes through the second polarization plate **420**, and the remaining portion of the light is blocked by the second polarization plate **420**. If no electric fields are applied to the liquid crystal layer **200** (Eoff), a portion of the light passes through the liquid crystal layer **200** and is rotated to oscillate along the second axis. The portion of the light that oscillates along the second axis passes through the inner polarization layer **880**, because the inner polarization layer **880** has a polarization axis that is substantially perpendicular to a polarization axis of the second polarization plate **420**, so that the portion of the light is reflected by the reflective plate **850** and passes through the inner polarization layer **880**. The portion of the light that exits from the inner polarization layer **880** enters the liquid crystal layer **200**. When the portion of the light exits from the liquid crystal layer **200**, this portion of the light is rotated by the liquid crystal layer **200** to pass through the second polarization plate **420**, thereby also resulting in white color being displayed.

[0129] When electric fields are applied to the liquid crystal layer **200** (Eon), the arrangement of liquid crystal molecules in the liquid crystal layer **200** is changed, so that the portion of light that passes through the second polarization plate **420** passes through the liquid crystal layer **200** without being rotated. Therefore, the portion of light that passes through the liquid crystal layer **200** without being rotated is blocked by the inner polarization layer **880**, so that the reflective plate **850** does not reflect light, thereby resulting in black color being displayed.

[0130] Transmissive Mode Operation

[0131] **FIG. 10B** corresponds to the transmissive mode of the transfective LCD apparatus in **FIG. 9**.

[0132] Referring to **FIG. 10B**, light generated from a backlight assembly advances toward the first polarization plate **410**. A portion of the light oscillates along the second axis and passes through the first polarization plate **410**, and the remaining portion of the light is blocked by the first polarization plate **410**. If no electric fields are applied to the liquid crystal layer **200** (Eoff), a portion of the light passes through the liquid crystal layer **200** and is rotated to oscillate along the first axis. The portion of the light that oscillates along the first axis passes through the second polarization plate **420**, because the second polarization plate **420** has a polarization axis that is substantially perpendicular to a polarization axis of the first polarization plate **410**, thereby also resulting in white color being displayed.

[0133] When electric fields are applied to the liquid crystal layer **200** (Eon), the arrangement of liquid crystal molecules in the liquid crystal layer **200** is changed, so that the portion of light that passes through the first polarization plate **410** passes through the liquid crystal layer **200** without being rotated. As a result, the portion of light that passes through the liquid crystal layer **200** without being rotated is blocked by the second polarization plate **420**, so that black color is displayed.

[0134] **FIGS. 11A through 11J** are cross-sectional views illustrating a method of manufacturing the LCD apparatus in **FIG. 9**.

[0135] Referring to **FIG. 11A**, a metal layer including but not limited to a metal such as tantalum (Ta), titanium (Ti), molybdenum (Mo), aluminum (Al), chromium (Cr), copper (Cu), tungsten (W), etc. is formed on the first transparent substrate **805** including but not limited to glass, ceramic, etc.

[0136] The metal layer is patterned to form a plurality of gate lines and a gate electrode **112** protruding from the gate line.

[0137] The gate insulation layer **114** including, for example silicon nitride is formed on the first transparent substrate **105** having the gate lines and the gate electrode **112** for covering the gate lines and the gate electrode **112**. The gate insulation layer **114** may be formed on all portions of an upper surface of the first transparent substrate **105**. Alternatively, the gate insulation layer **114** may be formed on only portions of the upper surface of the first transparent substrate **105** such that the gate insulation layer **114** covers the gate line and the gate electrode **112**.

[0138] In addition, an amorphous silicon (a-Si) layer is formed on the gate insulation layer **114** and n+ amorphous silicon (n+ a-Si) layer is formed on the amorphous silicon layer. The amorphous silicon layer and the n+ amorphous silicon layer are patterned to form the semiconductor layer **116** and the ohmic contact layer **118** of the thin film transistor, respectively.

[0139] A metal layer including but not limited to a metal such as tantalum (Ta), titanium (Ti), molybdenum (Mo), aluminum (Al), chromium (Cr), copper (Cu), tungsten (W), etc. is formed on the first transparent substrate **805** having the semiconductor layer **116** and the ohmic contact layer **118**. The metal layer is patterned to form a plurality of source lines, source electrode **120** protruding from the source lines, and drain electrode **122** which is spaced apart from the source electrode **120**.

[0140] Referring to **FIG. 11B**, the passivation layer **130** is formed on the first transparent substrate **805** having the plurality of source lines, the source electrode **120** and the drain electrode **122**, by way of, e.g. a spin coating method. A first primitive organic insulation layer **840-b** is formed on the passivation layer **130**.

[0141] Referring to **FIG. 11C**, a portion of the first primitive organic insulation layer **840-b** is removed to form a primitive connection hole that exposes a portion of the passivation layer **130**, and embossing patterns are formed on an upper surface of the first primitive organic insulation layer **840-b** to form a second primitive organic insulation layer **840-c**. For example, a photo mask MA having a transparent base substrate MA1 and opaque patterns MA2 is

disposed over the first primitive organic insulation layer **840-b**. The opaque patterns MA2 are formed on the transparent base substrate MA1. The first primitive organic insulation layer **840-b** is exposed and developed to form primitive embossing patterns, so that the second primitive organic insulation layer **840-c** is completed.

[0142] Referring to FIG. 11D, a portion of the passivation layer **130** is removed to form the connection hole CNT that exposes a portion of the drain electrode **122**. Then, a reflow-process is performed to smoothen a surface of the primitive embossing patterns of the second organic insulation layer **840-c**, so that the embossing patterns of the organic insulation layer **840** are formed.

[0143] Referring to FIG. 11E, the reflective plate **850** is formed on the organic insulation layer **840**. The planarization layer **860** is then formed on the reflective plate **850** of the reflective region RA and the organic insulation layer **840** of the transmissive region TA.

[0144] A metal layer including but not limited to a metal or a metal alloy such as aluminum (Al), silver (Ag), aluminum neodymium (AlNd), etc. is formed on the organic insulation layer **840**. The metal layer is patterned to form the reflective plate **850** which is electrically connected to the drain electrode **122**. The reflective plate **850** has a relatively thin thickness, so that the reflective plate **850** has the same or at least the same surface shape as that of the organic insulation layer **840**. In other words, the reflective plate **850** also includes embossing patterns. As a result, the reflective plate **850** resembles a plurality of convex mirrors and a plurality of concave mirrors.

[0145] Referring to FIG. 11F, the pixel electrode layer **870** is formed on the planarization layer **860**, and the inner polarization layer **880** is formed on the pixel electrode layer **870**.

[0146] Moreover, pixel electrode layer **870** defines a pixel electrode in a unit pixel region. The pixel electrode layer **870** is electrically connected to the reflective plate **850** which is electrically connected to the drain electrode **122**, through the connection hole CNT. The pixel electrode layer **870** includes an optically transparent and electrically conductive material such as indium tin oxide (ITO), indium zinc oxide (IZO), zinc oxide (ZO), etc. The pixel electrode layer **870** may be formed on a portion of an upper surface of the planarization layer **860**, which corresponds to pixel region. Alternatively, the pixel electrode layer **870** may be formed on all portions of the upper surface of the planarization layer **860**, and the pixel electrode layer **870** may be patterned.

[0147] The inner polarization layer **880** includes a disc type liquid crystal. The disc type liquid crystal is coated on the pixel electrode layer **870**, for example through a slit coating method, wherein a shear stress is applied along a desired polarization axis. The disc type liquid crystal is pre-cured.

[0148] Referring to FIG. 11G, a photoresist layer PR is formed on the inner polarization layer **880**. The photoresist layer PR is formed to have a relatively thick thickness at the reflective region RA and a relatively thin thickness at the transmissive region TA, for example through use of a half-tone mask. Alternatively, a thickness of the photoresist layer PR may be adjusted through a slit mask.

[0149] Referring to FIG. 11H, a portion of the inner polarization layer **880** and a portion of the pixel electrode layer **870**, which are not covered by the photoresist layer PR, are removed through a wet etching process or a dry etching process.

[0150] Referring to FIG. 11I, the photoresist layer PR is etched such that a first portion of the photoresist layer PR, which has a relatively thin thickness and is disposed at the transmissive region TA, is removed, and a second portion of the photoresist layer PR, which has a relatively thick thickness and is disposed at the reflective region RA, is retained.

[0151] Referring to FIG. 11J, a portion of the inner polarization layer **880**, which is not covered by the photoresist layer PR, is removed, for example through a wet etching process or a dry etching process. As a result of the above process, the reflective plate **850**, the planarization layer **860** disposed on the reflective plate **850**, the pixel electrode layer **870** disposed on the planarization layer **860**, and the inner polarization layer **880** disposed on the pixel electrode layer **870** are now disposed at the reflective region RA. Further, the planarization layer **860** disposed on the organic insulation layer **840**, and the pixel electrode **870** disposed on the planarization layer **860** are now disposed at the transmissive region TA.

[0152] Then, the first alignment layer **890** in FIG. 9 is formed on the inner polarization layer **880** of the reflective region RA, and the pixel electrode layer **870** of the transmissive region TA.

[0153] Additionally, to simplify the manufacturing process of the array substrate, after a photo process of forming the gate electrode **112**, the active layer including the semiconductor layer **116** and the ohmic contact layer **118**, the source and drain electrodes **120** and **122**, the passivation layer **130**, the contact hole and the embossing patterns and the planarization layer, the pixel electrode layer **870** and the inner polarization layer **880** may be formed through a similar photo process as the above-mentioned components.

[0154] FIG. 12 is a cross-sectional view illustrating an LCD apparatus according to an exemplary embodiment of the present invention.

[0155] Referring to FIG. 12, an LCD panel includes an array substrate **1100**, a liquid crystal layer **1180** and a color filter substrate **1190**. The array substrate **1100** and the color filter substrate **1190** are combined with each other, and the liquid crystal layer **1180** is disposed between the array substrate **1100** and the color filter substrate **1190**. In addition, a first polarization plate is disposed on a lower surface of the array substrate **1100** and a second polarization plate is disposed on an upper surface of the color filter substrate **1190**. The first and second polarization plates have different polarization axes. For example, the first polarization plate has a polarization axis that is substantially perpendicular to a polarization axis of the second polarization plate.

[0156] The array substrate **1100** includes a first transparent substrate **1105**, a gate line, a gate electrode **1112** and a gate insulation layer **1113**. The gate line is formed on the first transparent substrate **1105**, and the gate electrode **1113** protrudes from the gate line. The gate insulation layer **1113** is formed on the first transparent substrate **1105** such that the gate insulation layer **1113** covers the gate line and the gate electrode **1112**. The gate insulation layer **1113** includes, for

example silicon nitride (SiNx). The gate line and the gate electrode **1112** include but are not limited to a metal or a metal alloy such as aluminum (Al), aluminum alloy, silver (Ag), silver alloy, copper (Cu), copper alloy, molybdenum (Mo), molybdenum alloy, chromium (Cr), tantalum (Ta), titanium (Ti), etc.

[0157] The array substrate **1100** further includes a channel layer **1114**, a source electrode **1122** and a drain electrode **1123**. The channel layer **1114** covers the gate electrode **1112**. The source and drain electrodes **1122** and **1123** are spaced apart from each other, and the source and drain electrodes **1122** and **1123** cover a portion of the channel layer **1114**.

[0158] The channel layer **1114** includes, a semiconductor layer including for example amorphous silicon (a-Si), and the ohmic contact layer including, for example n-doped amorphous silicon (a-Si).

[0159] The gate electrode **1112**, the channel layer **1114**, the source electrode **1122** and the drain electrode **1123** form a thin film transistor (TFT). The source and drain electrodes **1122** and **1123** include but are not limited to a metal or a metal alloy such as aluminum (Al), aluminum alloy, silver (Ag), silver alloy, copper (Cu), copper alloy, molybdenum (Mo), molybdenum alloy, chromium (Cr), tantalum (Ta), titanium (Ti), etc.

[0160] The gate, source and drain electrodes **1112**, **1122** and **1123** have, for example a single layered structure. Alternatively, one of the gate, source and drain electrodes **1112**, **1122** and **1123** may have a multi-layered structure. When the gate, source and drain electrodes **1112**, **1122** and **1123** have a single layered structure, the gate, source and drain electrodes **1112**, **1122** and **1123** include but are not limited to a metal or a metal alloy such as aluminum (Al), aluminum neodymium (AlNd), copper (Cu), etc. When the gate, source and drain electrodes **1112**, **1122** and **1123** have, for example a double layered structure including a lower layer and an upper layer, the lower layer include but are not limited to a metal or a metal alloy such as chromium (Cr), molybdenum (Mo), molybdenum alloy, etc., and the upper layer includes a metal or a metal alloy such as aluminum, aluminum alloy, etc.

[0161] The array substrate **1100** further includes a passivation layer **1130**, an organic insulation layer **1132** and a pixel electrode layer **1140**. The passivation layer **1130** includes a contact hole that exposes a portion of the drain electrode **1123**. The passivation layer **1130** protects the channel layer **1114** disposed between the source and drain electrodes **1122** and **1123**. The pixel electrode layer **1140** is disposed at both of a reflective region RA and a transmissive region TA.

[0162] The organic insulation layer **1132** is formed on the passivation layer **1130**. The organic insulation layer **160** includes a contact hole that exposes a portion of the drain electrode **1123**. The organic insulation layer **1132** includes a photosensitive material, so that the contact hole is easily formed through a photolithography process. When the LCD panel does not utilize a contact hole, the organic insulation layer **1132** may include a material that is not photosensitive. The organic insulation layer **1132** includes a material having a relatively high optical transmittance of substantially equal to or more than about 90%. The organic insulation layer **1132** has embossing patterns, and the embossing patterns are formed on an upper surface of the organic insulation layer **1132**.

[0163] The pixel electrode layer **1140** is formed on the organic insulation layer **1132**. The pixel electrode layer **1140** is electrically connected to the drain electrode **1123** through the contact hole.

[0164] The array substrate **1100** further includes a buffer metal layer **1142**, a reflective plate **1146**, a planarization layer **1148** and an inner polarization layer **1150**. The buffer metal layer **1142** covers the pixel electrode layer **1140** of the reflective region RA. The reflective plate **1146** is formed on the buffer metal layer **1142**. The planarization layer **1148** is formed on the reflective plate **1146** of the reflective region RA and the pixel electrode layer **1140** of the transmissive region TA. The inner polarization layer **1150** is formed on the planarization layer **1148** of the reflective region RA.

[0165] The buffer metal layer **1142** reduces contact resistance between the pixel electrode layer **1140** and the reflective plate **1146**. The buffer metal layer **1142** includes, for example molybdenum tungsten (MoW).

[0166] The planarization layer **1148** includes a material that has a relatively high optical transmittance. Moreover, the planarization layer **1148** and the organic insulation layer **1132** preferably are comprised of the same material.

[0167] When the planarization layer **1148** includes different material from that of the organic insulation layer **1132**, a ratio of optical refractivity of the planarization layer **1148** to optical refractivity of the organic insulation layer **1132** is in a range of about a half to about one. That is because when an optical difference between the planarization layer **1246** and the organic insulation layer **1132** increases, the light-using efficiency is reduced.

[0168] Preferably, the planarization layer **180** has a relatively thin thickness, provided that the planarization layer **180** levels the embossing patterns. For example, when the embossing patterns have a height of about 0.5 μm , the planarization layer **180** preferably has a thickness of about 0.5 μm .

[0169] The inner polarization layer **1150** has a polarization axis that is substantially parallel with a polarization axis of the first polarization plate that is disposed on a lower surface of the array substrate **1100**.

[0170] The array substrate **1100** may further include an alignment layer formed on the inner polarization layer **1150**.

[0171] The color filter substrate **1190** includes a second transparent substrate **1192**, a light blocking layer, a color filter layer **1194**, an over coating layer **1196**, and a common electrode layer **1198**. The light blocking layer is formed on the second transparent substrate **1192** and includes a plurality of openings arranged in a matrix type shape. Each of the openings defines a pixel. The color filter layer **1194** is formed on the second transparent substrate **1192** exposed through the openings of the light blocking layer. The over coating layer **1196** is formed on the color filter layer **1194**. The common electrode layer **1198** is formed on the over coating layer **1196**. The color filter substrate **1190** may further include a second alignment layer formed on the common electrode layer **1198**.

[0172] The color filter substrate **1190** is combined with the array substrate **1100** such that the liquid crystal layer **1180** is disposed between the color filter substrate **1190** and the array substrate **1100**. The liquid crystal layer has a single cell gap.

[0173] According to the present exemplary embodiment, the buffer layer 1142 is disposed between the pixel electrode layer 1140 and the reflective plate 1146 to reduce a contact resistance between the pixel electrode layer 1140 including, for example ITO and the reflective plate 1146 including a metal.

[0174] The planarization layer 1148 is formed on the reflective plate 1146 having the embossing patterns to enhance optical reflectivity. The thin crystal film (TCF®) of Optiva Inc. in U.S.A may be coated on the planarization layer 1148, for example through a slot die coating method. Moreover, to form the inner polarization layer 1150, a shear stress is applied to the thin crystal film along a polarization axis in order to form the inner polarization layer 1150. The thin crystal film includes dyestuff of chromogen base.

[0175] The thin crystal film having above described optical characteristics may be employed by a transfective LCD apparatus for enhancing the display quality of the transfective LCD apparatus. As discussed, a typical transfective LCD apparatus includes both the reflective plate and transmissive window. By using a thin crystal film according to the exemplary embodiments of the present invention with a transfective LCD apparatus, a transfective LCD apparatus having a relatively high transmittance at the reflective region RA and a relatively high contrast ratio at the transmissive region is provided, thereby enhancing the display quality of the apparatus.

[0176] The thin crystal film corresponds to a polymer resin that is gel type and has a viscosity of about 300 psi. The thin crystal film may be formed, for example by the slot die coating method.

[0177] Hereinafter, a transmissive mode operation and a reflective mode operation of the transfective LCD apparatus according to the present exemplary embodiment will be explained. The transfective LCD apparatus that will be explained displays white color when no electric fields are applied to the liquid crystal layer 1180. In other words, the transfective LCD apparatus corresponds to a normally white mode. The transfective LCD apparatus includes a first polarization plate that has a first polarization axis disposed on the lower surface of the first transparent substrate 1105, inner polarization layer 1150 that has a polarization axis that is substantially parallel with the first polarization axis, and the second polarization plate that has a second polarization axis that is substantially perpendicular to the first polarization axis and is disposed on the upper surface of the second transparent substrate 1192.

[0178] FIGS. 13A and 13B are conceptual views illustrating a light path of the LCD apparatus in FIG. 12. Hereinafter, a 'first axis' is defined as an axis that is disposed on a paper of drawings, and a 'second axis' is defined as an axis that is substantially parallel with a normal line of the paper.

[0179] Reflective Mode Operation

[0180] FIG. 13A corresponds to the reflective mode of the transfective LCD apparatus in FIG. 12.

[0181] Referring to FIG. 13A, when external light advances toward the second polarization plate FPF, a portion of the light oscillates along the first axis and passes through the second polarization plate FPF, and the remaining portion

of the light is blocked by the second polarization plate FPF. If no electric fields are applied to the liquid crystal layer 1180 (Eoff), a portion of the light passes through the liquid crystal layer 1180 and is rotated to oscillate along the second axis. The portion of the light that oscillates along the second axis passes through the inner polarization layer 1150, because the inner polarization layer 1150 has a polarization axis that is substantially perpendicular to a polarization axis of the second polarization plate FPF. The portion of light that passes through the inner polarization layer 1150 passes through the planarization layer 1148, so that this portion of the light is reflected by the reflective plate 1146 and passes through the planarization layer 1148 and the inner polarization layer 190 in sequence. The portion of the light that exits from the inner polarization layer 1150 enters the liquid crystal layer 1180. When the portion of the light exits from the liquid crystal layer 1180, this portion of the light is rotated by the liquid crystal layer 1180 to pass through the second polarization plate FPF, thereby resulting in white color being displayed.

[0182] When electric fields are applied to the liquid crystal layer 1180 (Eon), the arrangement of liquid crystal molecules in the liquid crystal layer 1180 is changed, so that the portion of light that passes through the second polarization plate FPF passes through the liquid crystal layer 1180 without being rotated. As a result, the portion of light that passes through the liquid crystal layer 1180 without being rotated is blocked by the inner polarization layer 1150, so that the reflective plate 1146 does not reflect light, thereby resulting in black color being displayed.

[0183] Transmissive Mode Operation

[0184] FIG. 13B corresponds to the transmissive mode of the transfective LCD apparatus in FIG. 12.

[0185] Referring to FIG. 13B, light generated from a backlight assembly advances toward the first polarization plate RPF. A portion of that light oscillates along the second axis and passes through the first polarization plate RPF. The remaining portion of the light is blocked by the first polarization plate RPF. If no electric fields are applied to the liquid crystal layer 1180 (Eoff), a portion of the light passes through the liquid crystal layer 1180 and is rotated to oscillate along the first axis. The portion of the light that oscillates along the first axis passes through the second polarization plate FPF, because the second polarization plate FPF has a polarization axis that is substantially perpendicular to a polarization axis of the first polarization plate RPF, thereby resulting in white color being displayed.

[0186] When electric fields are applied to the liquid crystal layer 1180 (Eon), the arrangement of liquid crystal molecules in the liquid crystal layer 1180 is changed, so that the portion of light that passes through the first polarization plate RPF passes through the liquid crystal layer 1180 without being rotated. As a result, the portion of light that passes through the liquid crystal layer 1180 without being rotated is blocked by the second polarization plate FPF, so that black color is displayed.

[0187] FIG. 14 is a cross-sectional view illustrating an LCD apparatus according to an exemplary embodiment of the present invention.

[0188] Referring to FIG. 14, the LCD panel includes an array substrate 1200, a liquid crystal layer 1180 and a color

filter substrate **1190**. The array substrate **1200** and the color filter substrate **1190** are combined with each other, and the liquid crystal layer **1180** is disposed between the array substrate **1200** and the color filter substrate **1190**. Additionally, a first polarization plate is disposed on a lower surface of the array substrate **1200** and a second polarization plate is disposed on an upper surface of the color filter substrate **1190**. The first and second polarization plates have different polarization axes. For example, the first polarization plate has a polarization axis that is substantially perpendicular to a polarization axis of the second polarization plate. The LCD panel of the present exemplary embodiment is the same as the previous exemplary embodiment depicted in **FIGS. 12-13B** except for the array substrate **1200**. Thus, the same reference numerals will be used to refer to the same or like parts as those described in the exemplary embodiment depicted in **FIGS. 12-13B** and any further explanation concerning the above elements will be omitted.

[**0189**] The array substrate **1200** includes a buffer metal layer **1240**, a reflective plate **1242**, a planarization layer **1246**, a pixel electrode layer **1248** and an inner polarization layer **1250**. The buffer metal layer **1240** is formed on an organic insulation layer **1132** having embossing patterns. The buffer metal layer **1240** is electrically connected to a drain electrode **1123** through a contact hole of the organic insulation layer **1132**. The buffer metal layer **1240** is disposed at the reflective region RA. The reflective plate **1242** is formed on the buffer metal layer **1240** of the reflective region RA. The planarization layer **1246** is formed on the reflection plate **1242** of the reflective region RA and the organic insulation layer **1132** of the transmissive region TA. The pixel electrode layer **1248** is formed on the planarization layer **1246**. The pixel electrode layer **1248** is electrically connected to the reflective plate **1242**. The inner polarization layer **1250** is formed on the pixel electrode layer **1248** of the reflective region RA.

[**0190**] The ratio of optical refractivity of the planarization layer **1148** to optical refractivity of the organic insulation layer **1132** is in a range of about a half to about one. That is because when an optical difference between the planarization layer **1246** and the organic insulation layer **1132** increases, light-using efficiency is reduced.

[**0191**] The inner polarization layer **1250** has a polarization axis that is substantially parallel with a polarization axis of the first polarization plate which is disposed on the lower surface of the first transparent substrate **1105**.

[**0192**] The color filter substrate **1190** includes a second transparent substrate **1192**, a light blocking layer, a color filter layer **1194**, an over coating layer **1196**, and a common electrode layer **1198**. The light blocking layer is formed on the second transparent substrate **1192**. The light blocking layer includes a plurality of openings arranged in a matrix type shape. Each of the openings defines a pixel. The color filter layer **1194** is formed on the second transparent substrate **1192** exposed through the openings of the light blocking layer. The over coating layer **1196** is formed on the color filter layer **1194**. The common electrode layer **1198** is formed on the over coating layer **1196**. The color filter substrate **1190** may further include a second alignment layer formed on the common electrode layer **1198**.

[**0193**] The color filter substrate **1190** is combined with the array substrate **1100** such that the liquid crystal layer **1180**

is disposed between the color filter substrate **1190** and the array substrate **1100**. The liquid crystal layer has a single cell gap.

[**0194**] According to the present exemplary embodiment, the organic insulation layer **1132** includes a photosensitive material, so that the contact hole is easily formed through a photolithography process.

[**0195**] When the LCD panel does not utilize a contact hole, the organic insulation layer **1132** may instead include a material that is not photosensitive.

[**0196**] Further, according to the present exemplary embodiment, the pixel electrode layer **1248** is formed on the planarization layer **1246** and the inner polarization layer **1250** is formed on the pixel electrode layer **1248** in sequence. In other words, the pixel electrode layer **1248** is disposed between the planarization layer **1246** and the inner polarization layer **1250**, so that the stability of manufacturing process is further enhanced.

[**0197**] **FIGS. 15A and 15B** are conceptual views illustrating a light path of the LCD apparatus in **FIG. 14**. Hereinafter, a 'first axis' is defined as an axis that is disposed on a paper of drawings, and a 'second axis' is defined as an axis that is substantially parallel with a normal line of the paper.

[**0198**] Reflective Mode Operation

[**0199**] **FIG. 15A** corresponds to the reflective mode of the transfective LCD apparatus in **FIG. 14**.

[**0200**] Referring to **FIG. 15A**, when external light advances toward the second polarization plate FPF, a portion of this light oscillates along the first axis and passes through the second polarization plate FPF, and the remaining portion of the light is blocked by the second polarization plate FPF. If no electric fields are applied to the liquid crystal layer **1180** (Eoff), a portion of the light passes through the liquid crystal layer **1180** and is rotated to oscillate along the second axis. The portion of the light that oscillates along the second axis passes through the inner polarization layer **1250**, because the inner polarization layer **1250** has a polarization axis that is substantially perpendicular to a polarization axis of the second polarization plate FPF. Further, the portion of light that passes through the inner polarization layer **1250** passes through the planarization layer **1246**, so that the portion of the light is reflected by the reflective plate **1242** and passes through the planarization layer **1246** and the inner polarization layer **1250** in sequence. The portion of the light that exits from the inner polarization layer **1250** enters the liquid crystal layer **1180**. When the portion of the light exits from the liquid crystal layer **1180**, this portion of the light is rotated by the liquid crystal layer **1180** to pass through the second polarization plate FPF, thereby resulting in white color being displayed.

[**0201**] When electric fields are applied to the liquid crystal layer **1180** (Eon), the arrangement of liquid crystal molecules in the liquid crystal layer **1180** is changed, so that the portion of light that passes through the second polarization plate FPF passes through the liquid crystal layer **1180** without being rotated. As a result, the portion of light that passes through the liquid crystal layer **1180** without being rotated is blocked by the inner polarization layer **1250**, so

that the reflective plate **1242** does not reflect light, thereby resulting in black color being displayed.

[0202] Transmissive Mode Operation

[0203] FIG. 15B corresponds to the transmissive mode of the transmissive LCD apparatus in FIG. 14.

[0204] Referring to FIG. 15B, light generated from a backlight assembly advances toward the first polarization plate RPF. A portion of that light oscillates along the second axis and passes through the first polarization plate RPF. The remaining portion of the light is blocked by the first polarization plate RPF. If no electric fields are applied to the liquid crystal layer **1180** (Eoff), a portion of the light passes through the liquid crystal layer **1180** and is rotated to oscillate along the first axis. The portion of the light that oscillates along the first axis passes through the second polarization plate FPF, because the second polarization plate FPF has a polarization axis that is substantially perpendicular to a polarization axis of the first polarization plate RPF, thereby also resulting in a white color being displayed.

[0205] When electric fields are applied to the liquid crystal layer **1180** (Eon), the arrangement of liquid crystal molecules in the liquid crystal layer **1180** is changed, so that the portion of light that passes through the first polarization plate RPF passes through the liquid crystal layer **1180** without being rotated. As a result, the portion of light that passes through the liquid crystal layer **1180** without being rotated is blocked by the second polarization plate FPF, so that black color is displayed.

[0206] FIG. 16 is a cross-sectional view illustrating an LCD apparatus according to an exemplary embodiment of the present invention.

[0207] Referring to FIG. 16, an LCD panel includes an array substrate **1300**, a liquid crystal layer **1180** and a color filter substrate **1190**. The array substrate **1300** and the color filter substrate **1190** are combined with each other, and the liquid crystal layer **1180** is disposed between the array substrate **1300** and the color filter substrate **1190**. Moreover, a first polarization plate is disposed on a lower surface of the array substrate **1300** and a second polarization plate is disposed on an upper surface of the color filter substrate **1190**. The first and second polarization plates have different polarization axes. For example, the first polarization plate has a polarization axis that is substantially perpendicular to a polarization axis of the second polarization plate. The LCD panel of the present exemplary embodiment is same as the previous exemplary embodiment depicted in FIGS. 12-13B except for the array substrate **1300**. Thus, the same reference numerals will be used to refer to the same or like parts as those described in the exemplary embodiment depicted in FIGS. 12-13B and any further explanation concerning the above elements will be omitted.

[0208] The array substrate **1300** includes a buffer metal layer **1340**, a reflective plate **1342**, a planarization layer **1344**, an inner polarization layer **1346** and a pixel electrode layer **1348**. The buffer metal layer **1340** is formed on an organic insulation layer **1132** having embossing patterns. The buffer metal layer **1340** is electrically connected to a drain electrode **1123** through a contact hole of the organic insulation layer **1132**. The buffer metal layer **1340** is disposed at the reflective region RA. The reflective plate **1342** is formed on the buffer metal layer **1340** of the reflective

region RA. The planarization layer **1344** is formed on the reflection plate **1342** of the reflective region RA and the organic insulation layer **1132** of the transmissive region TA. The inner polarization layer **1346** is formed on the planarization layer **1344** of the reflective region RA. The pixel electrode layer **1348** is formed on the inner polarization layer **1346** of the reflective region RA and the planarization layer **1344** of the transmissive region TR. The pixel electrode layer **1348** is electrically connected to the buffer metal layer **1340** or the drain electrode **1123**.

[0209] The ratio of optical refractivity of the planarization layer **1344** to optical refractivity of the organic insulation layer **1132** is in a range of about a half to about one. That is because when an optical difference between the planarization layer **1344** and the organic insulation layer **1132** increases, light-using efficiency is reduced.

[0210] The inner polarization layer **1346** has a polarization axis that is substantially parallel with a polarization axis of the first polarization plate which is disposed on the lower surface of the first transparent substrate **1105**.

[0211] The color filter substrate **1190** includes a second transparent substrate **1192**, a light blocking layer, a color filter layer **1194**, an over coating layer **1196**, and a common electrode layer **1198**. The light blocking layer is formed on the second transparent substrate **1192** and may include a plurality of openings arranged in a matrix type shape. Each of the openings defines a pixel. The color filter layer **1194** is formed on the second transparent substrate **1192** exposed through the openings of the light blocking layer. The over coating layer **1196** is formed on the color filter layer **1194**. The common electrode layer **1198** is formed on the over coating layer **1196**. The color filter substrate **1190** may further include a second alignment layer formed on the common electrode layer **1198**.

[0212] The color filter substrate **1190** is combined with the array substrate **1100** such that the liquid crystal layer **1180** is disposed between the color filter substrate **1190** and the array substrate **1100**. The liquid crystal layer has a single cell gap.

[0213] According to the present exemplary embodiment, the organic insulation layer **1132** includes a photosensitive material, so that the contact hole is easily formed through a photolithography process.

[0214] When the LCD panel does not require a contact hole, the organic insulation layer **1132** may instead include a material that is not photosensitive.

[0215] According to the present exemplary embodiment, the inner polarization layer **1346** is formed on the planarization layer **1344**, and the pixel electrode layer **1348** is formed on the inner polarization layer **1346** in sequence. In other words, the pixel electrode layer **1348** is disposed between the first alignment layer and the inner polarization layer **1346**.

[0216] FIGS. 17A and 17B are conceptual views illustrating a light path of the LCD apparatus in FIG. 16. Hereinafter, a 'first axis' is defined as an axis that is disposed on a paper of drawings, and a 'second axis' is defined as an axis that is substantially parallel with a normal line of the paper.

[0217] Reflective Mode Operation

[0218] FIG. 17A corresponds to the reflective mode of the transfective LCD apparatus in FIG. 16.

[0219] Referring to FIG. 17A, when external light advances toward the second polarization plate FPF. A portion of that light oscillates along the first axis and passes through the second polarization plate FPF, and the remaining portion of the light is blocked by the second polarization plate FPF. If no electric fields are applied to the liquid crystal layer 1180 (Eoff), a portion of the light passes through the liquid crystal layer 1180 and is rotated to oscillate along the second axis. The portion of the light that oscillates along the second axis passes through the inner polarization layer 1346, because the inner polarization layer 1346 has a polarization axis that is substantially perpendicular to a polarization axis of the second polarization plate FPF. The portion of light that passes through the inner polarization layer 1346 passes through the planarization layer 1344, so that the portion of the light is reflected by the reflective plate 1342 and passes through the planarization layer 1344 and the inner polarization layer 1344 in sequence. The portion of the light that exits from the inner polarization layer 1344 enters the liquid crystal layer 1180. When the portion of the light that exits from the liquid crystal layer 1180, this portion of the light is rotated by the liquid crystal layer 1180 to pass through the second polarization plate FPF, thereby resulting in white color being displayed.

[0220] When electric fields are applied to the liquid crystal layer 1180 (Eon), the arrangement of liquid crystal molecules in the liquid crystal layer 1180 is changed, so that the portion of light that passes through the second polarization plate FPF passes through the liquid crystal layer 1180 without being rotated. Therefore, the portion of light that passes through the liquid crystal layer 1180 without being rotated is blocked by the inner polarization layer 1346, so that the reflective plate 1342 does not reflect light, thereby resulting in black color being displayed.

[0221] Transmissive Mode Operation

[0222] FIG. 17B corresponds to the transmissive mode of the transfective LCD apparatus in FIG. 16.

[0223] Referring to FIG. 17B, light generated from a backlight assembly advances toward the first polarization plate RPF. A portion of that light oscillates along the second axis and passes through the first polarization plate RPF, and the remaining portion of the light is blocked by the first polarization plate RPF. If no electric fields are applied to the liquid crystal layer 1180 (Eoff), a portion of the light passes through the liquid crystal layer 1180 and is rotated to oscillate along the first axis. The portion of the light that oscillates along the first axis passes through the second polarization plate FPF, because the second polarization plate FPF has a polarization axis that is substantially perpendicular to a polarization axis of the first polarization plate RPF, thereby also resulting in white color being displayed.

[0224] When electric fields are applied to the liquid crystal layer 1180 (Eon), the arrangement of liquid crystal molecules in the liquid crystal layer 1180 is changed, so that the portion of light that passes through the first polarization plate RPF passes through the liquid crystal layer 1180 without being rotated. As a result, the portion of light that

passes through the liquid crystal layer 1180 without being rotated is blocked by the second polarization plate FPF, so that black color is displayed.

[0225] According to the exemplary embodiments of the present invention, the inner polarization layer is formed at the reflective region inside of the LCD panel having a single cell gap structure. For example, the inner polarization layer may be disposed between the reflective plate and the liquid crystal layer.

[0226] Additionally, the pixel electrode layer and the inner polarization layer may be formed through the same photo process to simplify the method of manufacturing the transfective LCD panel. For instance, after the pixel electrode layer is formed, the inner polarization layer is coated on the pixel electrode layer, and then the pixel electrode layer and the inner polarization layer are patterned by a slit mask or a half-tone mask. Thus, productivity is enhanced.

[0227] Moreover, the inner polarization layer may be formed on a planarization layer having flat surface, so that light leakage caused by a curved surface is prevented. To enhance optical reflectivity, the planarization layer is formed on the reflective plate having an embossing pattern. In addition, a thin crystal film is formed on the planarization layer having flat surface, for example through slot die coating method, so that the inner polarization layer having the flat surface is formed.

[0228] In addition, the pixel electrode layer may be formed on the planarization layer and the inner polarization layer may be formed on the pixel electrode layer. In other words, the pixel electrode layer may be disposed between the planarization layer and the inner polarization layer to enhance manufacturing stability.

[0229] Still further, the inner polarization layer may be formed on the planarization layer and the pixel electrode layer may be formed on the inner polarization layer. In other words, the pixel electrode layer is disposed between the first alignment layer and the inner polarization layer to enhance stability of liquid crystal layer.

[0230] Having described the exemplary embodiments of the present invention and its advantages, it is further noted that it is readily apparent to those of reasonable skill in the art that various modifications can be made herein without departing from the spirit and scope of the invention which is defined by the metes and bounds of the appended claims.

What is claimed is:

1. An array substrate comprising:
 - a transparent substrate having a reflective region and a transmissive region;
 - a switching device formed in the reflective region;
 - an insulation layer formed on the transparent substrate to cover the switching device, the insulation layer having a contact hole that exposes a portion of an electrode of the switching device;
 - a pixel electrode that is electrically connected to the electrode of the switching device through the contact hole;

- a reflective plate that is electrically connected to the pixel electrode, the reflective plate disposed on the reflective region; and
- an inner polarization layer that covers the reflective plate.
2. The array substrate of claim 1, wherein an upper surface of the insulation layer has a substantially same height throughout the reflective and transmissive regions with respect to the transparent substrate.
3. The array substrate of claim 1, further comprising a planarization layer formed on the reflective plate having embossing patterns.
4. The array substrate of claim 3, wherein the inner polarization layer is formed on the planarization layer.
5. The array substrate of claim 1, wherein the reflective plate comprises a plurality of protruded portions and a plurality of recessed portions.
6. The array substrate of claim 5, further comprising a planarization layer disposed between the reflective plate and the inner polarization layer.
7. The array substrate of claim 1, wherein the inner polarization layer has a flat surface.
8. An array substrate comprising:
- a substrate;
 - a switching device formed on the substrate, the switching device comprising a gate electrode, a source electrode and a drain electrode;
 - a transparent electrode layer that is electrically connected to the drain electrode of the switching device;
 - a reflective plate that is electrically connected to the drain electrode;
 - a planarization layer formed on the reflective plate; and
 - an inner polarization layer formed on the planarization layer.
9. The array substrate of claim 8, wherein the inner polarization layer covers the reflective plate.
10. The array substrate of claim 8, wherein the planarization layer has a flat surface.
11. The array substrate of claim 8, further comprising a polarization plate having a polarization axis that is substantially parallel with a polarization axis of the inner polarization layer.
12. The array substrate of claim 8, wherein the transparent electrode layer is disposed between the planarization layer and the inner polarization layer.
13. The array substrate of claim 8, wherein the transparent electrode layer is formed on the inner polarization layer.
14. The array substrate of claim 8, further comprising a photosensitive insulation layer having embossing patterns and an optical transmittance of substantially equal to or more than about 90%.
15. The array substrate of claim 8, wherein the planarization layer has an optical transmittance of substantially equal to or more than about 90%.
16. A method of manufacturing an array substrate, comprising:
- forming an insulation layer on a substrate having a switching device, the insulation layer having a contact hole that exposes a portion of a drain electrode of the switching device;
 - forming a transparent electrode layer that is electrically connected to the drain electrode through the contact hole;
 - forming a reflective plate that is electrically connected to the transparent electrode; and
 - forming an inner polarization layer on the reflective plate.
17. The method of claim 16, further comprising forming embossing patterns at the insulation layer.
18. The method of claim 16, further comprising forming a planarization layer on the reflective plate and forming an alignment layer having a uniform rubbing direction on the planarization and the inner polarization layer.
19. The method of claim 16, further comprising removing a portion of the reflective plate to form a transmissive window.
20. The method of claim 18, wherein the inner polarization layer is formed on the planarization layer.
21. A liquid crystal display (LCD) apparatus comprising:
- a first substrate;
 - a second substrate combined with the first substrate, the second substrate including a reflective plate, a pixel electrode and a polarization layer covering the reflective plate; and
 - a liquid crystal layer disposed between the first and second substrates.
22. The LCD apparatus of claim 21, further comprising a first polarization plate that is disposed on an upper surface of the first substrate.
23. The LCD apparatus of claim 22, wherein a polarization axis of the polarization layer is substantially perpendicular to a polarization axis of the first polarization plate.
24. The LCD apparatus of claim 21, further comprising a second polarization plate that is disposed on a lower surface of the second substrate.
25. The LCD apparatus of claim 24, wherein a polarization axis of the inner polarization layer is substantially perpendicular to a polarization axis of the first polarization plate.
26. The LCD apparatus of claim 21, wherein the reflective plate has relatively high portions and relatively low portions, and wherein the inner polarization layer is formed on the reflective plate to have a flat surface.
27. The LCD apparatus of claim 21, further comprising a planarization layer, wherein the reflective plate has relatively high portions and relatively low portions, the planarization layer is formed on the reflective plate to have flat surface, and wherein the inner polarization layer is formed on the planarization layer.
28. The LCD apparatus of claim 21, wherein the reflective plate has relatively high portions and relatively low portions, and wherein the inner polarization layer is formed on the reflective plate to have a uniform thickness.
29. The LCD apparatus of claim 21, wherein the inner polarization layer includes a disc type liquid crystal.
30. The LCD apparatus of claim 21, wherein the liquid crystal layer has a uniform cell gap.
31. The LCD apparatus of claim 21, wherein the liquid crystal layer comprises a twisted nematic liquid crystal configuration.
32. The LCD apparatus of claim 21, wherein the second substrate further comprises a planarization layer disposed between the reflective plate and the inner polarization layer.

33. A liquid crystal display (LCD) apparatus having a reflective region and a transmissive region, comprising:

- a lower substrate comprising:
 - a substrate;
 - a switching device formed on the substrate, the switching device having a gate electrode, a source electrode and a drain electrode;
 - an insulation layer formed on the substrate to cover the switching device, the insulation layer having a contact hole that exposes a portion of the drain electrode of the switching device;
 - a reflective plate formed on the insulation layer of the reflective region such that the reflective plate is electrically connected to the drain electrode through the contact hole;
 - a planarization layer formed on the reflective plate of the reflective region, and the insulation layer of the transmissive region;
 - a transparent electrode layer formed on the planarization layer such that the transparent electrode is electrically connected to the drain electrode; and
 - an inner polarization layer formed on the transparent electrode layer of the reflective region to cover the reflective plate;
 - an upper substrate that faces the lower substrate; and
 - a liquid crystal layer disposed between the lower and upper substrate such that the liquid crystal layer has a uniform cell gap throughout the reflective and transmissive regions.
- 34.** The LCD apparatus of claim 33, wherein the reflective plate has a flexuous surface.
- 35.** The LCD apparatus of claim 33, wherein the upper substrate comprises color filters.
- 36.** A liquid crystal display (LCD) apparatus comprising:
- a lower substrate including:
 - a first transparent substrate;
 - a switching device formed on the first transparent substrate, the switching device having a gate electrode, a source electrode and a drain electrode;

- a transparent electrode layer that is electrically connected to the drain electrode of the switching device;
 - a reflective plate that is electrically connected to the drain electrode of the switching device, the reflective plate having flexuous surface;
 - a planarization layer formed on the reflective plate, the planarization layer having a flat surface; and
 - an inner polarization layer formed on the planarization layer;
- an upper substrate combined with the lower substrate; and
- a liquid crystal layer disposed between the lower and upper substrates.

37. The LCD apparatus of claim 36, wherein the inner polarization layer covers the reflective plate.

38. The LCD apparatus of claim 36, wherein the liquid crystal layer has a uniform cell gap.

39. The LCD apparatus of claim 36, further comprising a first polarization plate disposed on a lower surface of the lower substrate, the first polarization plate having a polarization axis that is substantially parallel with a polarization axis of the inner polarization layer.

40. The LCD apparatus of claim 36, further comprising a second polarization plate disposed on an upper surface of the upper substrate, the second polarization plate having a polarization axis that is substantially perpendicular to a polarization axis of the inner polarization layer.

41. The LCD apparatus of claim 36, wherein the transparent electrode layer is disposed between the planarization layer and the inner polarization layer.

42. The LCD apparatus of claim 36, wherein the transparent electrode layer is formed on the inner polarization layer.

43. The LCD apparatus of claim 36, further comprising a photosensitive insulation layer having embossing patterns and an optical transmittance of substantially equal to or more than about 90%.

44. The LCD apparatus of claim 36, wherein the planarization layer has an optical transmittance of substantially equal to or more than about 90%.

* * * * *

专利名称(译)	阵列基板，其制造方法以及具有该阵列基板的液晶显示装置		
公开(公告)号	US20060125986A1	公开(公告)日	2006-06-15
申请号	US11/299595	申请日	2005-12-12
[标]申请(专利权)人(译)	CHOO DAE HO 姜浩MIN HWANG JAE HOON OH JEONG MIN 朴贞WOO 权敏SUNG YUN DAE SEUNG		
申请(专利权)人(译)	秋dae-ho KANG HO-MIN HWANG宰勋 OH JEONG-MIN PARK JUNG-WOO KWON MIN-SUNG 云DAE-SEUNG		
当前申请(专利权)人(译)	SAMSUNG ELECTRONICS CO. , LTD.		
[标]发明人	CHOO DAE HO KANG HO MIN HWANG JAE HOON OH JEONG MIN PARK JUNG WOO KWON MIN SUNG YUN DAE SEUNG		
发明人	CHOO, DAE-HO KANG, HO-MIN HWANG, JAE-HOON OH, JEONG-MIN PARK, JUNG-WOO KWON, MIN-SUNG YUN, DAE-SEUNG		
IPC分类号	G02F1/1335		
CPC分类号	G02F1/133504 G02F1/133528 G02F1/133555 G02F1/1368 G02F1/1396 G02F2001/133357		
优先权	1020040104951 2004-12-13 KR 1020050010929 2005-02-05 KR 1020050010697 2005-02-04 KR		
外部链接	Espacenet USPTO		

摘要(译)

阵列基板包括透明基板，开关器件，绝缘层，像素电极，反射板和内偏振层。透明基板具有反射区域和透射区域。开关装置形成在反射区域中。绝缘层形成在透明基板上以覆盖开关装置。绝缘层具有接触孔，该接触孔暴露开关装置的漏电极的一部分。像素电极通过接触孔电连接到开关装置的漏电极。反射板电连接到像素电极并设置在反射区域。内偏振层覆盖反射板。因此，增强了具有上述阵列基板的LCD装置的白色亮度和对比度。

