



US008610864B2

(12) **United States Patent**
Lee et al.

(10) **Patent No.:** **US 8,610,864 B2**
(45) **Date of Patent:** **Dec. 17, 2013**

(54) **LIQUID CRYSTAL DISPLAY**

(75) Inventors: **Eun-Guk Lee**, Seoul (KR); **Byung-Duk Yang**, Yongin-si (KR); **Hyang-Shik Kong**, Seongnam-si (KR); **Se-Hwan Yu**, Asan-si (KR); **Sang-ki Kwak**, Cheonan-si (KR); **Kyoung-Tai Han**, Suwon-si (KR); **Dong-Yoon Kim**, Seoul (KR)

(73) Assignee: **Samsung Display Co., Ltd.**, Yongin (KR)

(*) Notice: Subject to any disclaimer, the term of this patent is extended or adjusted under 35 U.S.C. 154(b) by 559 days.

(21) Appl. No.: **12/560,976**

(22) Filed: **Sep. 16, 2009**

(65) **Prior Publication Data**

US 2010/0195034 A1 Aug. 5, 2010

(30) **Foreign Application Priority Data**

Feb. 3, 2009 (KR) 10-2009-0008417

(51) **Int. Cl.**
G02F 1/1343 (2006.01)
G02F 1/1337 (2006.01)

(52) **U.S. Cl.**
USPC **349/144**; 349/129; 349/142

(58) **Field of Classification Search**

USPC 349/129-131, 142-146
See application file for complete search history.

(56) **References Cited**

U.S. PATENT DOCUMENTS

2003/0043336 A1* 3/2003 Sasaki et al. 349/187
2008/0297708 A1* 12/2008 Yang et al. 349/136
2009/0190058 A1* 7/2009 Jung et al. 349/48
2010/0001276 A1* 1/2010 Kim et al. 257/59

* cited by examiner

Primary Examiner — Bumsuk Won

Assistant Examiner — Charles Chang

(74) *Attorney, Agent, or Firm* — H.C. Park & Associates, PLC

(57) **ABSTRACT**

A liquid crystal display according to an exemplary embodiment of the present invention includes: a pixel electrode including a first subpixel electrode and a second subpixel electrode with a gap therebetween; a common electrode facing the pixel electrode; and a liquid crystal layer formed between the pixel electrode and the common electrode, and including a plurality of liquid crystal molecules, wherein the first and second subpixel electrodes include a plurality of minute branches, the first and second subpixel electrodes include a plurality of subregions having different length directions of the minute branches, and the width of the minute branches is wider than an interval between the neighboring minute branches.

17 Claims, 14 Drawing Sheets

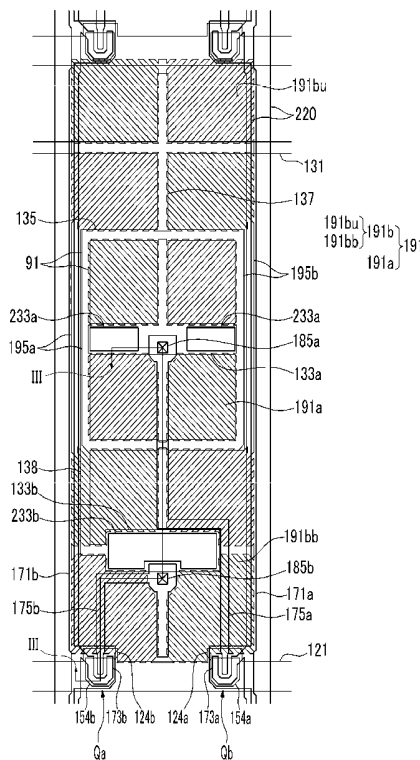

FIG. 1

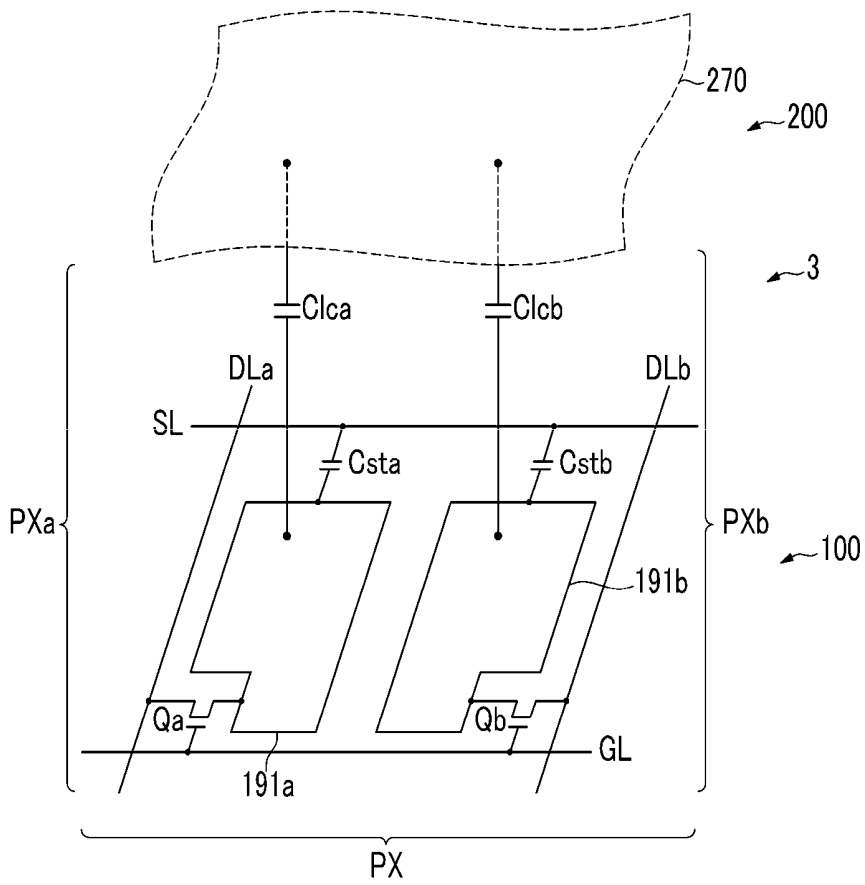

FIG. 3

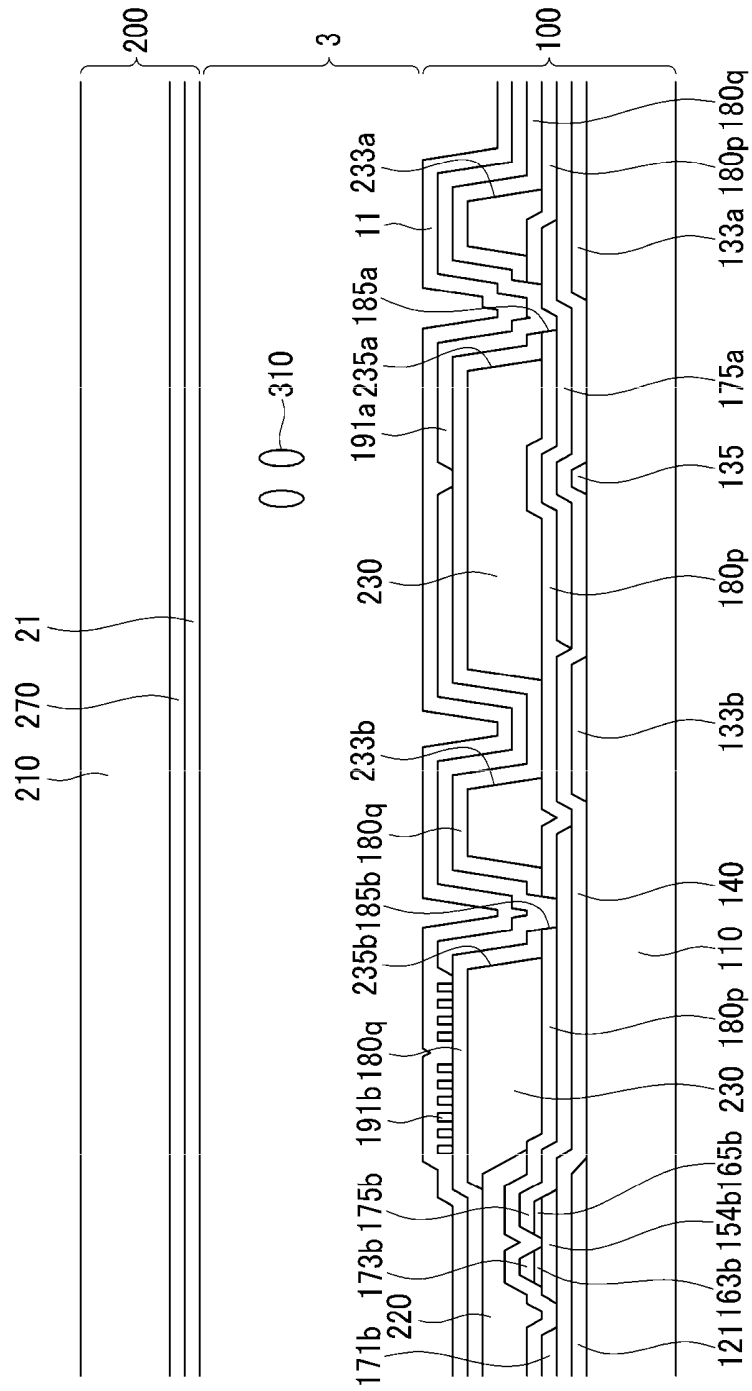

FIG. 4

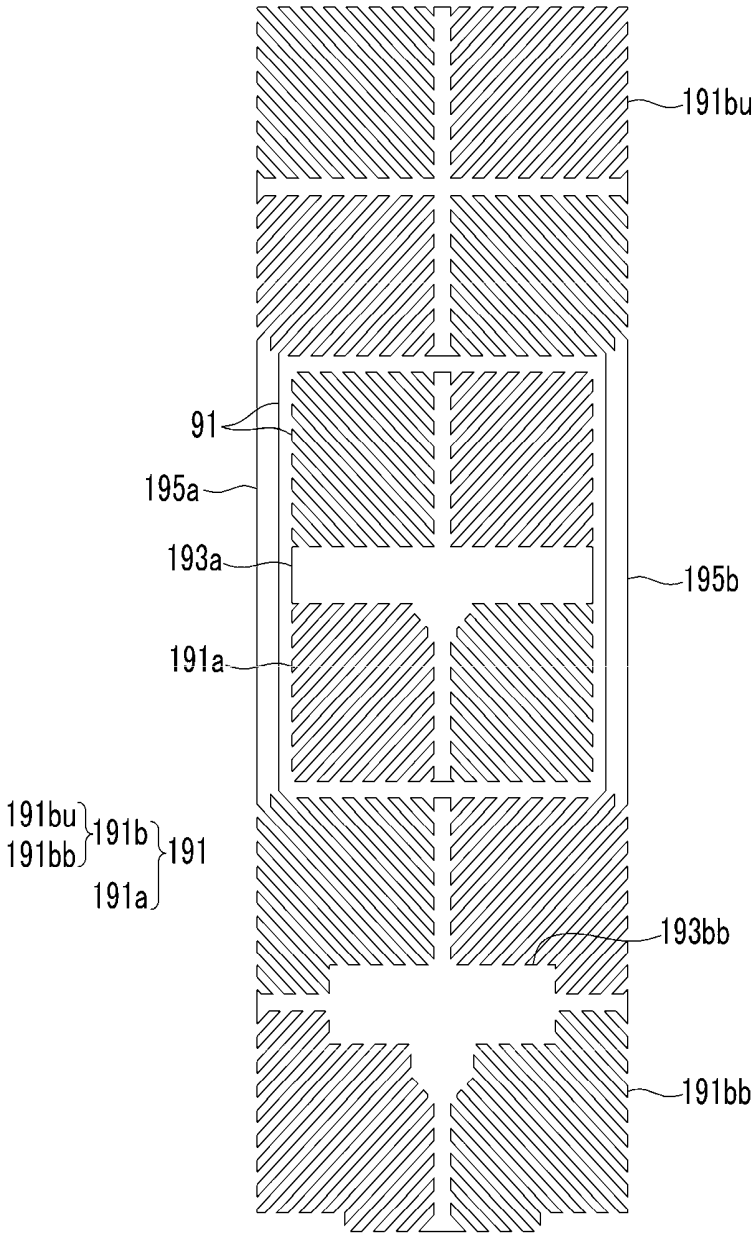

FIG. 5

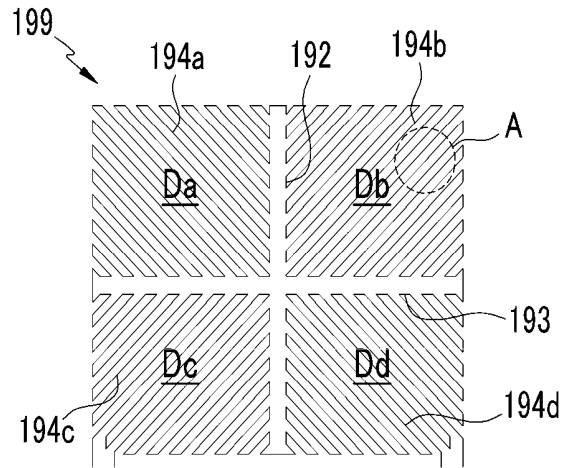

FIG. 6

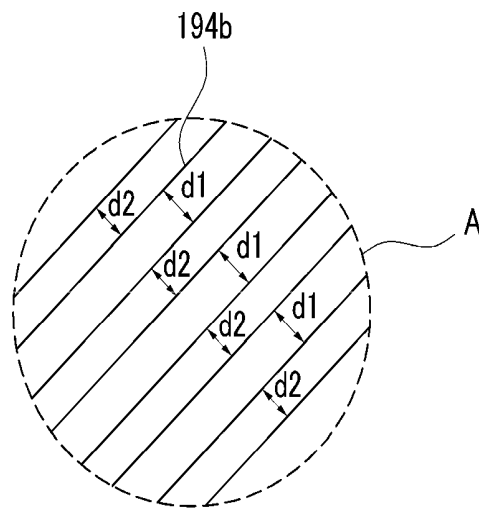

FIG. 7

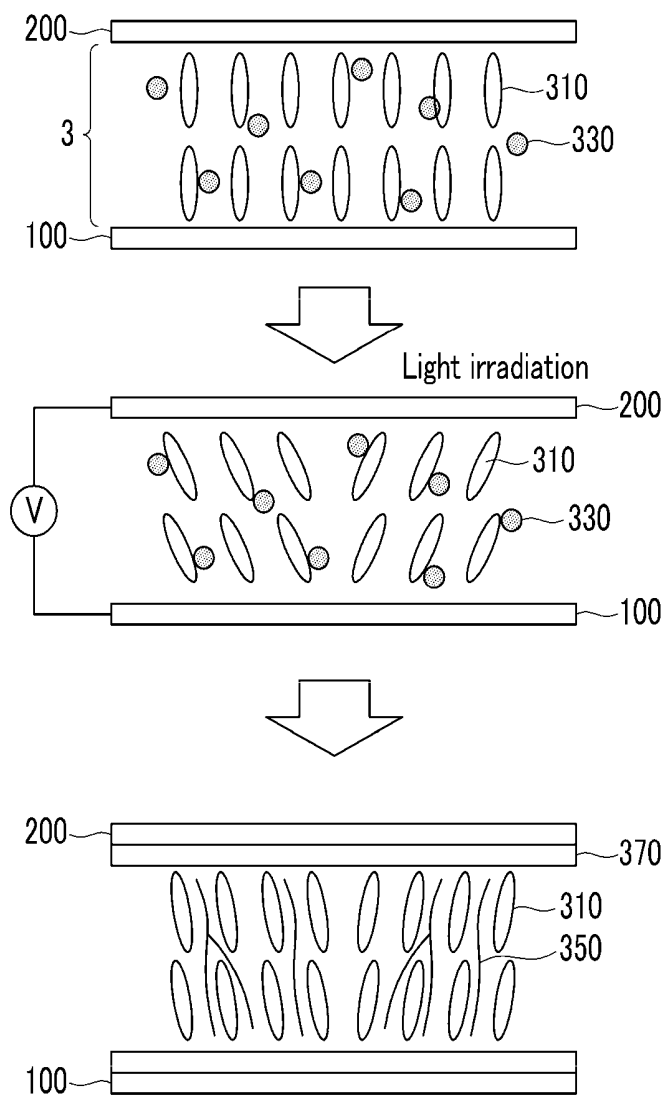

FIG.9

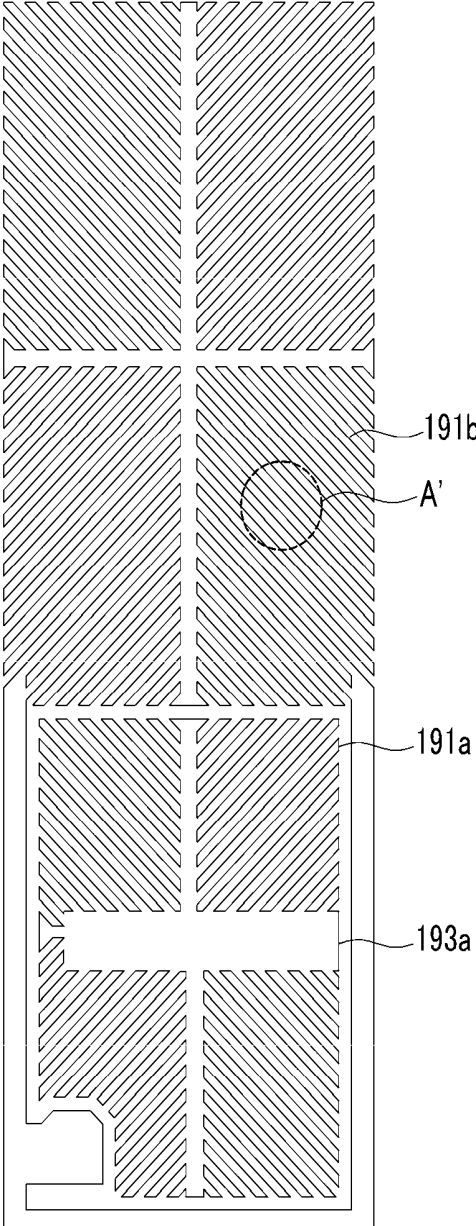

FIG.10

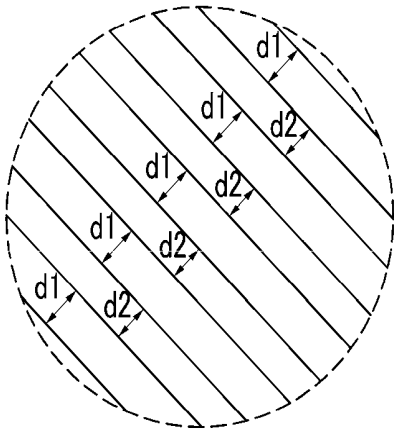

FIG. 11

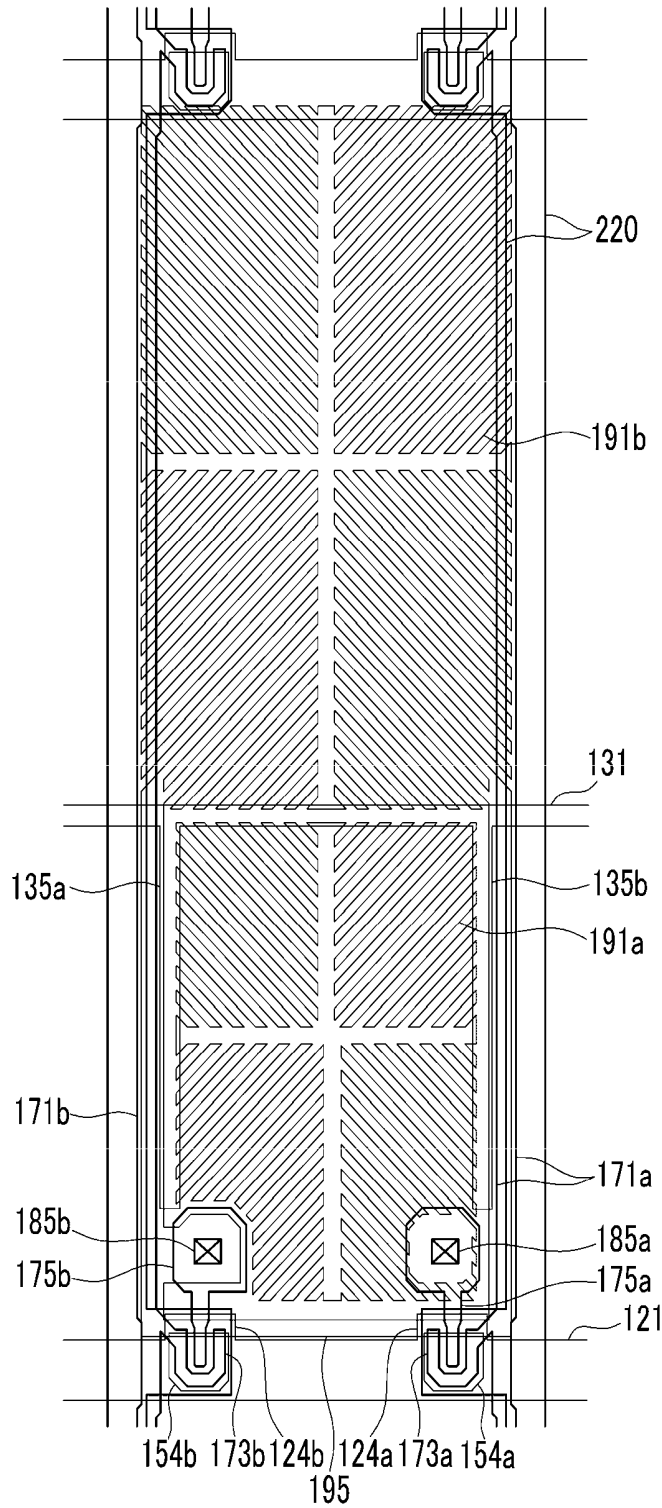

FIG. 12

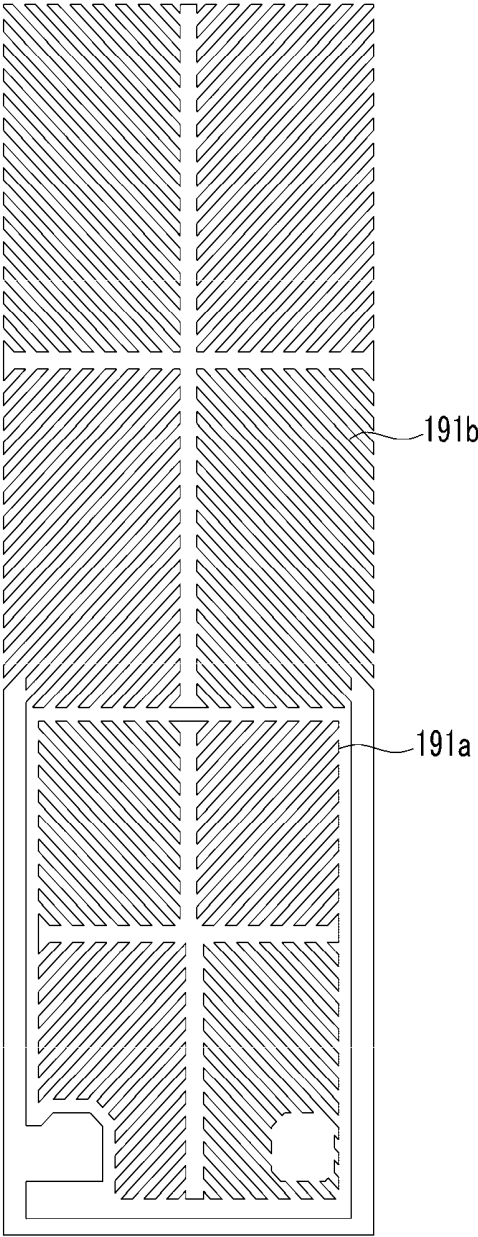

FIG.13

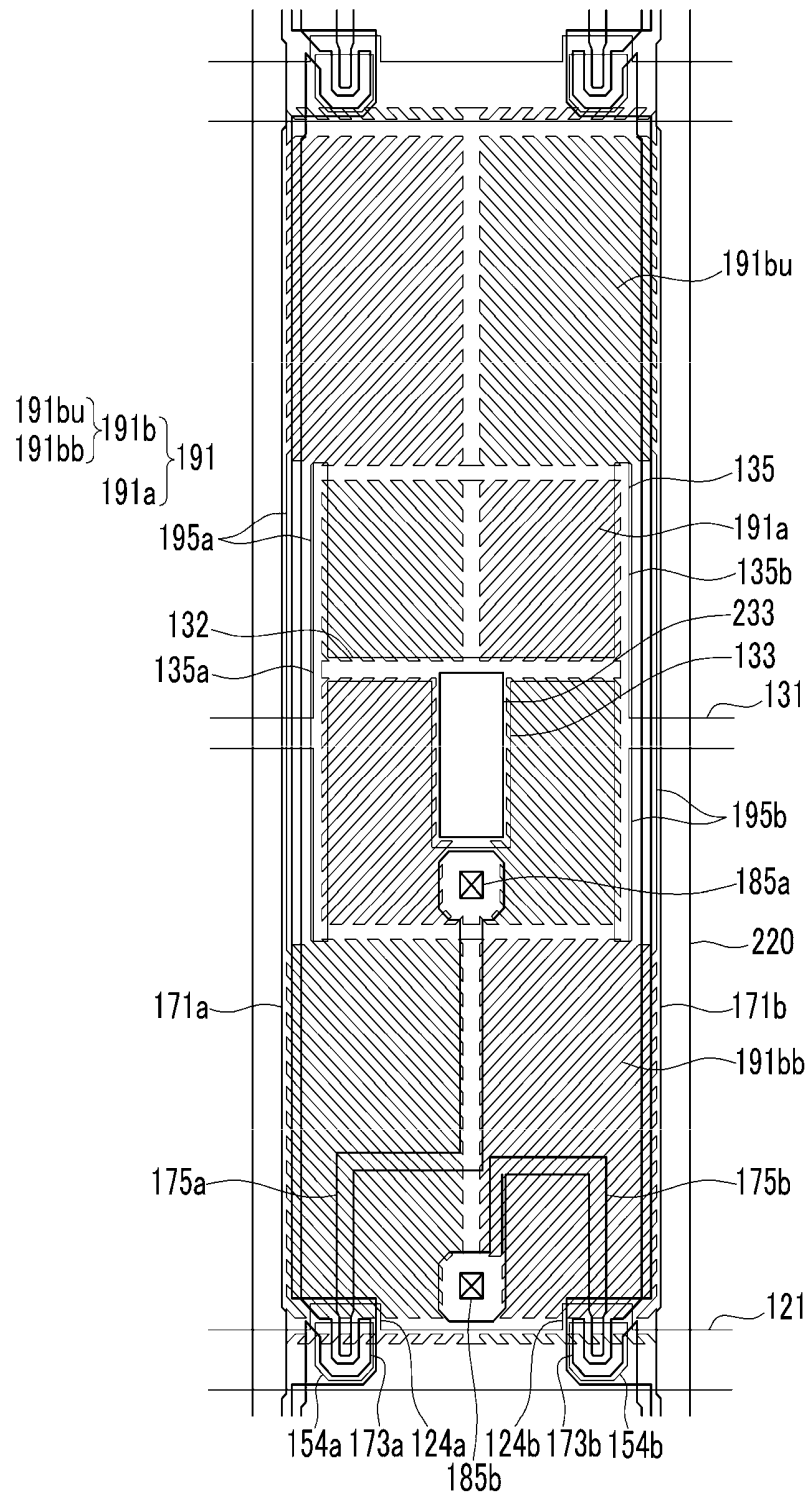

FIG. 14

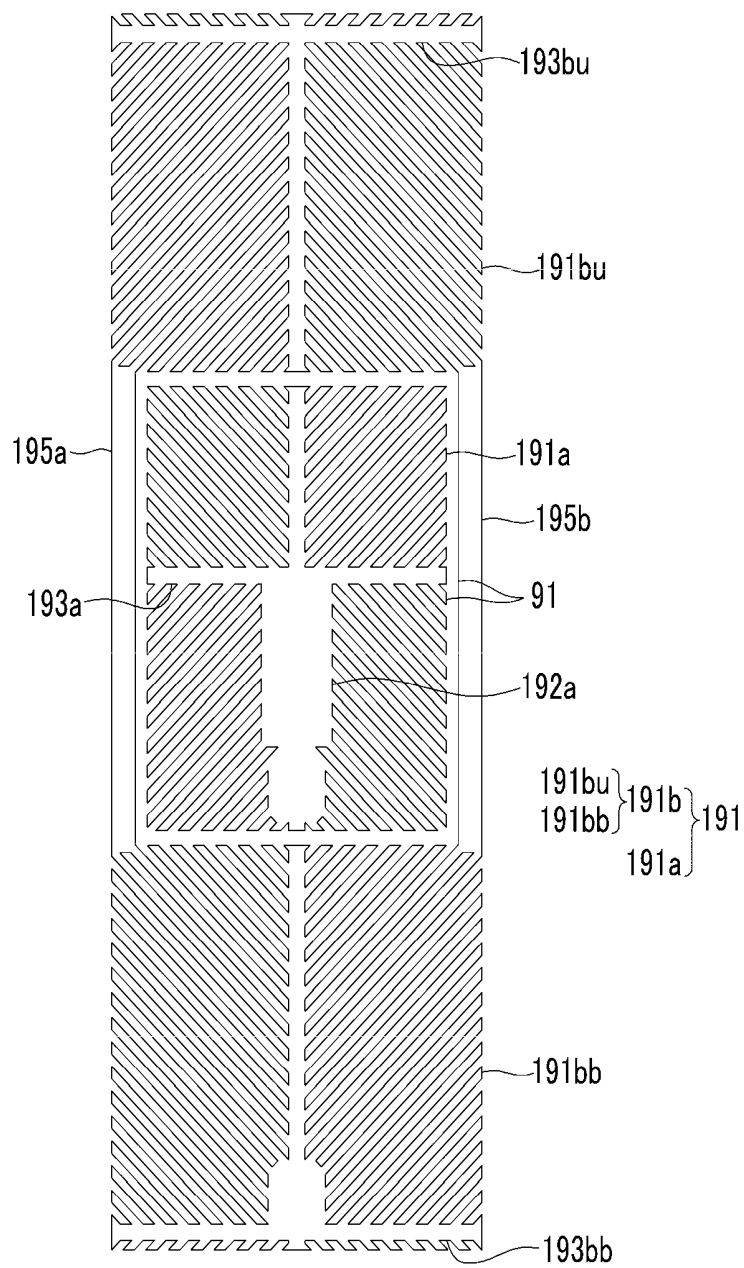
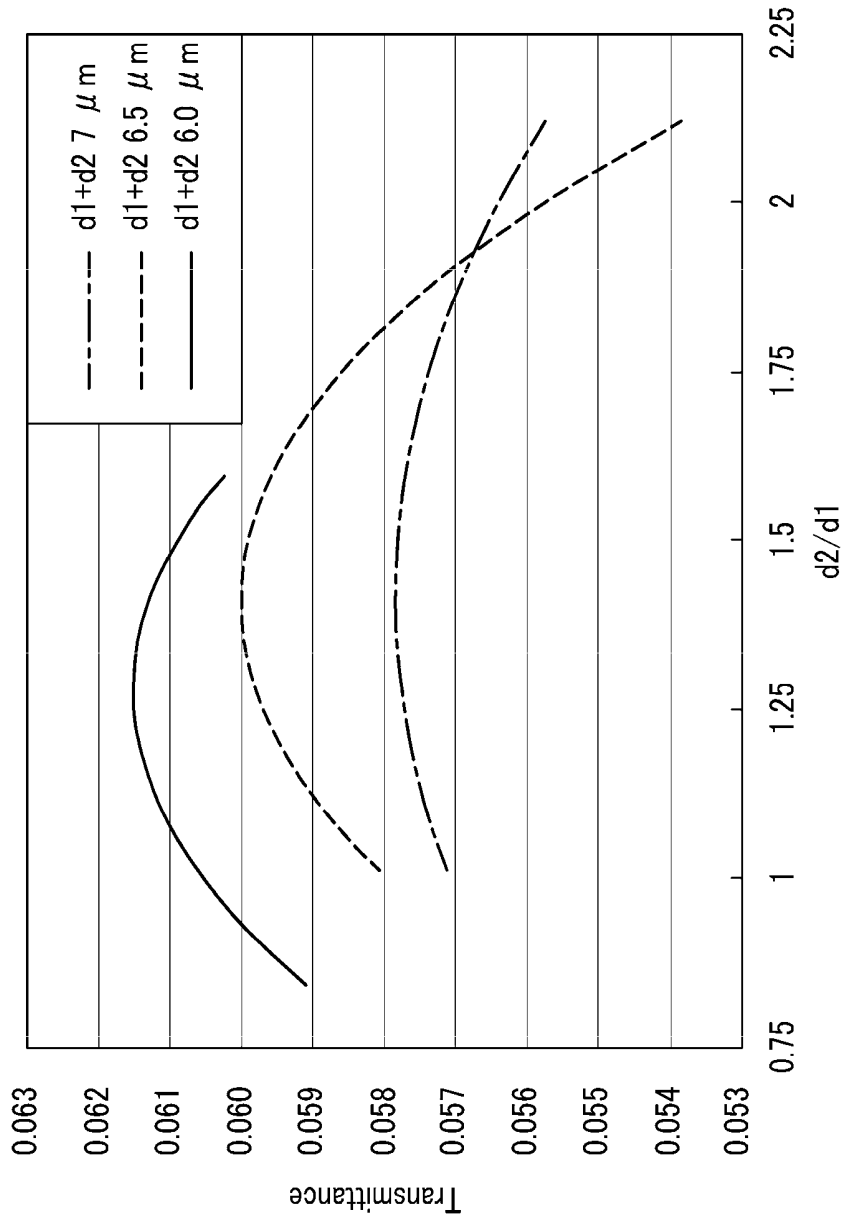

FIG. 15



LIQUID CRYSTAL DISPLAY**CROSS REFERENCE TO RELATED APPLICATION**

This application claims priority from and the benefit of Korean Patent Application No. 10-2009-0008417, filed on Feb. 3, 2009, which is hereby incorporated by reference for all purposes as if fully set forth herein.

BACKGROUND OF THE INVENTION**1. Field of the Invention**

Exemplary embodiments of the present invention relate to a liquid crystal display.

2. Discussion of the Background

A liquid crystal display (LCD) is one type of the widely used flat panel displays (FPDs). The LCD is composed of two display panels on which field generating electrodes such as pixel electrodes and a common electrode are formed, and a liquid crystal layer is disposed between the two display panels. In the liquid crystal display, voltages are applied to the field generating electrodes to generate an electric field over the liquid crystal layer, which determines the alignment of liquid crystal molecules of the liquid crystal layer. Accordingly, the polarization of incident light is controlled, thereby performing image display.

A vertical alignment mode LCD, which arranges major axes of liquid crystal molecules perpendicular to the display panel in a state in which the electric field is not applied, has been developed.

In the VA mode LCD, the important issue of a wide viewing angle can be realized by forming cutouts such as minute slits in the field-generating electrodes and protrusions on the field-generating electrodes. Since the cutouts and protrusions can determine the tilt directions of the liquid crystal molecules, the tilt directions can be distributed into various directions by using the cutouts and protrusions such that the reference viewing angle is widened.

Also, a method for providing a pretilt to the liquid crystal molecules in the absence of an electric field has been developed to improve the response speed of the liquid crystal while realizing the wide viewing angle. For the liquid crystal molecules to have the pretilt in various directions, alignment layers having various alignment directions may be used, or the liquid crystal layer is applied with an electric field and a thermal or light-hardened material is added, and light may be irradiated to slope the liquid crystal molecules in predetermined directions.

On the other hand, the VA mode liquid crystal display has lower side visibility compared with front visibility, such that one pixel is divided into two subpixels and different voltages are applied to the subpixels to solve this problem.

The above information disclosed in this Background section is only for enhancement of understanding of the background of the invention and therefore it may contain information that does not form part of the prior art.

SUMMARY OF THE INVENTION

Exemplary embodiments of the present invention provide a liquid crystal display having a wide viewing angle and a fast response speed, as well as excellent visibility and transmittance.

Additional features of the invention will be set forth in the description which follows, and in part will be apparent from the description, or may be learned by practice of the invention.

A liquid crystal display according to an exemplary embodiment of the present invention includes a pixel electrode including a first subpixel electrode and a second subpixel electrode with a gap therebetween. A common electrode faces the pixel electrode and a liquid crystal layer is formed between the pixel electrode and the common electrode. The liquid crystal layer includes a plurality of liquid crystal molecules. The first subpixel electrode and the second subpixel electrode include a plurality of minute branches. The first subpixel electrode and the second subpixel electrode include a plurality of subregions having different length directions of the minute branches, and the width of the minute branches is wider than the interval between neighboring minute branches. It is to be understood that both the foregoing general description and the following detailed description are exemplary and explanatory and are intended to provide further explanation of the invention as claimed.

BRIEF DESCRIPTION OF THE DRAWINGS

The accompanying drawings, which are included to provide a further understanding of the invention and are incorporated in and constitute a part of this specification, illustrate embodiments of the invention, and together with the description serve to explain the principles of the invention.

FIG. 1 is an equivalent circuit diagram of one pixel in a liquid crystal display according to an exemplary embodiment of the present invention.

FIG. 2 is a layout view of a liquid crystal display according to an exemplary embodiment of the present invention.

FIG. 3 is a cross-sectional view of the liquid crystal display shown in FIG. 2 taken along line III-III.

FIG. 4 is a top plan view showing the pixel electrode of the liquid crystal display shown in FIG. 2.

FIG. 5 is a top plan view of a basic electrode of the pixel electrode according to an exemplary embodiment of the present invention.

FIG. 6 is an enlarged view of portion A of the basic electrode shown in FIG. 5.

FIG. 7 is a view showing a process of providing a pretilt angle to liquid crystal molecules by using prepolymer that are polarized by light such as ultraviolet rays.

FIG. 8 is a layout view of a liquid crystal display according to another exemplary embodiment of the present invention.

FIG. 9 is a top plan view of a pixel electrode of the liquid crystal display shown in FIG. 8.

FIG. 10 is an enlarged view of portion A' of the basic electrode shown in FIG. 9.

FIG. 11 is a layout view of a liquid crystal display according to another exemplary embodiment of the present invention.

FIG. 12 is a top plan view of a pixel electrode of the liquid crystal display shown in FIG. 11.

FIG. 13 is a layout view of a liquid crystal display according to another exemplary embodiment of the present invention.

FIG. 14 is a top plan view of a pixel electrode of the liquid crystal display shown in FIG. 13.

FIG. 15 is a graph showing a transmittance result of a liquid crystal display according to one experimental example of the present invention.

DETAILED DESCRIPTION OF THE ILLUSTRATED EMBODIMENTS

The present invention is described more fully hereinafter with reference to the accompanying drawings, in which

exemplary embodiments of the invention are shown. This invention may, however, be embodied in many different forms and should not be construed as limited to the embodiments set forth herein. Rather, these embodiments are provided so that this disclosure is thorough, and will fully convey the scope of the invention to those skilled in the art. In the drawings, the size and relative sizes of layers, films, panels, regions, etc., may be exaggerated for clarity. Like reference numerals in the drawings denote like elements.

It will be understood that when an element such as a layer, film, region, or substrate is referred to as being “on” or “connected to” another element, it can be directly on or directly connected to the other element or intervening elements may be present. In contrast, when an element is referred to as being “directly on” or “directly connected to” another element, there are no intervening elements present.

FIG. 1 is an equivalent circuit diagram of one pixel in a liquid crystal display according to an exemplary embodiment of the present invention.

Referring to FIG. 1, a liquid crystal display according to an exemplary embodiment of the present invention includes signal lines including a plurality of gate lines GL, a plurality of pairs of data lines DL_a and DL_b, and a plurality of storage electrode lines SL, and a plurality of pixels PX connected to the signal lines. From the point of view of a structure, the liquid crystal display includes a lower panel 100 and an upper panel 200 facing each other, and a liquid crystal layer 3 interposed therebetween.

Each pixel PX includes a pair of subpixels PX_a and PX_b. Each subpixel PX_a and PX_b has a respective switching element Q_a and Q_b, liquid crystal capacitor Cl_{ca} and Cl_{cb}, and storage capacitor C_{sta} and C_{stb}.

Each switching element Q_a and Q_b is a three-terminal element such as a thin film transistor provided on the lower panel 100, having a control terminal connected to the gate line GL, an input terminal connected to the respective data line DL_a and DL_b, and an output terminal connected to the respective liquid crystal capacitor Cl_{ca} and Cl_{cb} and the respective storage capacitor C_{sta} and C_{stb}.

Each liquid crystal capacitor Cl_{ca} and Cl_{cb} uses a respective subpixel electrode 191_a and 191_b and a common electrode 270 as two terminals. The liquid crystal layer 3 between the electrodes 191_a and 191_b and 270 functions as a dielectric material.

Each storage capacitor C_{sta} and C_{stb} serving as an assistant to the respective liquid crystal capacitor Cl_{ca} and Cl_{cb} is formed as a storage electrode line SL provided on the lower display panel 100 and overlaps with the respective subpixel electrode 191_a and 191_b with an insulator interposed therebetween, and a predetermined voltage such as the common voltage V_{com} is applied thereto.

A predetermined difference is generated between voltages charged to the two liquid crystal capacitors Cl_{ca} and Cl_{cb}. For example, the data voltage applied to the liquid crystal capacitor Cl_{ca} is less than or greater than the data voltage applied to the liquid crystal capacitor Cl_{cb}. Therefore, when the voltages of the first liquid crystal capacitor Cl_{ca} and the second liquid crystal capacitor Cl_{cb} are appropriately adjusted, it is possible to make an image viewed from the side be as similar as possible to an image viewed from the front, and as a result, it is possible to improve the side visibility.

Next, a liquid crystal display according to an exemplary embodiment of the present invention will be described in detail with reference to FIG. 2, FIG. 3, FIG. 4, FIG. 5 and FIG. 6.

FIG. 2 is a layout view of a liquid crystal display according to an exemplary embodiment of the present invention, FIG. 3

is a cross-sectional view of the liquid crystal display shown in FIG. 2 taken along line III-III, FIG. 4 is a top plan view showing the pixel electrode of the liquid crystal display shown in FIG. 2, FIG. 5 is a top plan view of a basic electrode of the pixel electrode according to an exemplary embodiment of the present invention, and FIG. 6 is an enlarged view of portion A of the basic electrode shown in FIG. 5.

Referring to FIG. 2 and FIG. 3, a liquid crystal display according to an exemplary embodiment of the present invention includes the lower panel 100 and the upper panel 200 facing each other, and the liquid crystal layer 3 interposed between two display panels 100 and 200.

Firstly, the lower panel 100 will be described.

A plurality of gate lines 121 and a plurality of storage electrode lines 131 are formed on an insulating substrate 110.

The gate lines 121 transmit gate signals and are substantially extended in the transverse direction. Each gate line 121 includes a plurality of first gate electrodes 124_a and second gate electrodes 124_b protruding upward.

The storage electrode lines 131 include a stem extending substantially parallel to the gate lines 121, and a plurality of branches extended from the stem. Each branch includes a longitudinal portion 137, a hook-shaped portion 135, an expansion 138, a first storage electrode 133_a, and a second storage electrode 133_b.

The longitudinal portion 137 is extended upward and downward from the stem (hereinafter, an imaginary straight line in the direction that the longitudinal portion 137 is extended is referred to as a “longitudinal central line”).

The hook-shaped portion 135 is substantially rectangular, and an upper edge thereof vertically meets the longitudinal portion 137.

The first storage electrode 133_a extends in a transverse direction from a center of a left edge of the hook-shaped portion 135 to a center of a right edge, and has a width wider than the longitudinal portion 137 or the hook-shaped portion 135. The first storage electrode 133_a and the longitudinal portion 137 vertically meet each other.

The left edge of the hook-shaped portion 135 is connected to the second storage electrode 133_b through the expansion 138 that is extended downward and is curved in the right direction. The width of the second storage electrode 133_b is expanded and is extended substantially parallel to the first storage electrode 133_a in the transverse direction.

However, the shapes and arrangements of the storage electrode lines 131, 133_a, 133_b, 135, 137, and 138 may be modified in various forms.

A gate insulating layer 140 is formed on the gate lines 121 and the storage electrode lines 131, 133_a, 133_b, 135, 137, and 138, and a plurality of semiconductors 154_a and 154_b preferably made of amorphous or crystallized silicon are formed on the gate insulating layer 140.

A plurality of pairs of ohmic contacts 163_b and 165_b are formed on the first semiconductor 154_b, and the ohmic contacts 163_b and 165_b may be formed of a material such as n⁺ hydrogenated amorphous silicon in which an n-type impurity is doped with a high concentration, or of silicide.

A plurality of pairs of data lines 171_a and 171_b and a plurality of pairs of first drain electrodes 175_a and second drain electrodes 175_b are formed on the ohmic contacts 163_b and 165_b, and on the gate insulating layer 140.

The data lines 171_a and 171_b transmit data signals, extend substantially in the longitudinal direction, and cross the gate lines 121 and the storage electrode lines 131. Each data line 171_a and 171_b includes a plurality of first source electrodes 173_a and second source electrodes 173_b extending toward the respective first gate electrodes 124_a and second gate elec-

trodes **124b** and are curved with a “U” shape. The first source electrodes **173a** and the second source electrodes **173b** are opposite to the respective first drain electrodes **175a** and second drain electrodes **175b** with respect to the first gate electrodes **124a** and the second gate electrodes **124b**.

Each first drain electrode **175a** starts from one end enclosed by the first source electrode **173a**, extends upward, curves in the left direction according to the upper edge of the second storage electrode **133b**, and again extends upward near the longitudinal central line to form the other end. The other end of the first drain electrode **175a** is extended to where the second storage electrode **133b** is disposed, and has a wide area for connection with another layer.

Each second drain electrode **175b** starts from one end enclosed by the second source electrode **173b**, extends upward to the second storage electrode **133b**, curves in the right direction, extends according to the lower edge of the second storage electrode **133b**, expands with a wide area near the longitudinal central line, and again extends downward.

However, the shapes and arrangements of the first drain electrodes **175a** and the second drain electrodes **175b** and the data lines **171a** and **171b** may be modified in various forms.

A first gate electrode **124a** and a second gate electrode **124b**, a first source electrode **173a** and a second source electrode **173b**, and a first drain electrode **175a** and a second drain electrode **175b** respectively form a first thin film transistor (TFT) **Qa** and a second TFT **Qb** along with a first semiconductor **154a** and a second semiconductor **154b**, and a channel of the first TFT **Qa** and the second TFT **Qb** is formed on the first semiconductor **154a** and the second semiconductor **154b** between the first source electrode **173a** and the second source electrode **173b** and the first drain electrode **175a** and the second drain electrode **175b**.

The ohmic contacts **163b** and **165b** are interposed only between the underlying semiconductor islands **154a** and **154b**, and the overlying data lines **171a** and **171b** and drain electrodes **175a** and **175b**, and reduce contact resistance between them. The semiconductors **154a** and **154b** have a portion that is exposed without being covered by the data lines **171a** and **171b** and the drain electrodes **175a** and **175b**, and a portion between the source electrodes **173a** and **173b** and the respective drain electrodes **175a** and **175b**.

A lower passivation layer **180p** preferably made of silicon nitride or silicon oxide is formed on the data lines **171a** and **171b**, the drain electrodes **175a** and **175b**, and the exposed portions of the semiconductors **154a** and **154b**.

A plurality of light blocking members **220** referred to as a black matrix and separated by a predetermined interval from each other are formed on the lower passivation layer **180p**. The light blocking members **220** may include a stripe portion extending upward and downward, and a quadrangle portion corresponding to the thin film transistor, and they prevent light leakage.

A plurality of color filters **230** are formed on the lower passivation layer **180p** and the light blocking members **220**. The color filters **230** are mostly formed in a region surrounded by the light blocking members **220**. The color filters **230** have a plurality of holes **235a** and **235b** disposed on the first drain electrodes **175a** and the second drain electrodes **175b**, and a plurality of openings **233a** and **233b** disposed on the first storage electrodes **133a** and the second storage electrodes **133b**. The opening **233a** and **233b** reduce the thickness of the dielectric material forming the storage capacitors **Csta** and **Cstb** such that the storage capacitance may be increased.

Here, the lower passivation layer **180p** may prevent the pigments of the color filters **230** from flowing into the exposed semiconductors **154a** and **154b**.

An upper passivation layer **180q** is formed on the light blocking members **220** and the color filters **230**. The upper passivation layer **180q** may be made of an inorganic insulating material such as silicon nitride or silicon oxide, and prevents the color filters **230** from lifting and suppresses contamination of the liquid crystal layer **3** by organic material such as a solvent flowing from the color filters **230** such that defects such as an afterimage that may be generated during driving may be prevented.

However, at least one of the light blocking members **220** and the color filters **230** may be disposed on the upper panel **200**, and one of the lower passivation layer **180p** and the upper passivation layer **180q** of the lower panel **100** may be omitted in this case.

The upper passivation layer **180q** and the lower passivation layer **180p** have a plurality of contact holes **185a** and **185b** respectively exposing the first drain electrodes **175a** and the second drain electrodes **175b**.

A plurality of pixel electrodes **191** are formed on the upper passivation layer **180q**, and the above-described color filters **230** may be extended according to a column of the pixel electrodes **191**.

Referring to FIG. 4, each pixel electrode **191** includes the first subpixel electrode **191a** and the second subpixel electrode **191b** that are separated from each other by a gap **91** of a quadrangular belt shape, and each first subpixel electrode **191a** and each second subpixel electrode **191b** respectively include a basic electrode **199** shown in FIG. 5, or at least one modification thereof.

Next, the basic electrode **199** will be described in detail with reference to FIG. 5.

As shown in FIG. 5, the overall shape of the basic electrode **199** is a quadrangle, and it includes a cross-shaped stem having a transverse stem **193** and a longitudinal stem **192** that are crossed. Also, the basic electrode **199** is divided into a first subregion **Da**, a second subregion **Db**, a third subregion **Dc**, and a fourth subregion **Dd** by the transverse stem **193** and the longitudinal stem **192**. The first subregion **Da** includes a plurality of first minute branches **194a**, the second subregion **Db** includes a plurality of second minute branches **194b**, the third subregion **Dc** includes a plurality of third minute branches **194c**, and the fourth subregion **Dd** includes a plurality of fourth minute branches **194d**.

The first minute branches **194a** obliquely extend from the transverse stem **193** or the longitudinal stem **192** in the upper-left direction, and the second minute branches **194b** obliquely extend from the transverse stem **193** or the longitudinal stem **192** in the upper-right direction. Also, the third minute branches **194c** obliquely extend from the transverse stem **193** or the longitudinal stem **192** in the lower-left direction, and the fourth minute branches **194d** obliquely extend from the transverse stem **193** or the longitudinal stem **192** in the lower-right direction.

The first minute branches **194a**, the second minute branches **194b**, the third minute branches **194c** and the fourth minute branches **194d** form an angle of about 45 degrees or 135 degrees with the gate lines **121** or the transverse stem **193**. Also, the minute branches **194a**, **194b**, **194c** and **194d** of two neighboring subregions **Da**, **Db**, **Dc** and **Dd** may be crossed.

Next, widths of the minute branches **194a**, **194b**, **194c** and **194d** of the pixel electrodes **191** of the liquid crystal display according to an exemplary embodiment of the present invention, and intervals between neighboring minute branches **194a**, **194b**, **194c** and **194d** within each subregion **Da**, **Db**, **Dc** and **Dd**, will be described with reference to FIG. 6. FIG. 6 is an enlarged view of portion A of the basic electrode shown in FIG. 5.

As shown in FIG. 6 using the minute branches **194b** of the second subregion **Db** for illustration, the width **d1** of the minute branches **194a**, **194b**, **194c** and **194d** of the liquid crystal display according to an exemplary embodiment of the present invention may be wider than the interval **d2** between the neighboring minute branches **194a**, **194b**, **194c**, **194d** in each of the respective subregions **Da**, **Db**, **Dc** and **Dd**. Also, the ratio **d1/d2** of the width **d1** of the minute branches **194a**, **194b**, **194c**, **194d** to the width of the interval **d2** between respective neighboring minute branches **194a**, **194b**, **194c**, **194d** may be changed according to the sum of the width **d1** of the minute branches **194a**, **194b**, **194c**, **194d** and the interval **d2** between the respective neighboring minute branches **194a**, **194b**, **194c**, **194d**.

In detail, when the sum of the width **d1** of the minute branches **194a**, **194b**, **194c**, **194d** and the interval **d2** between respective neighboring minute branches **194a**, **194b**, **194c**, **194d** in the liquid crystal display according to an exemplary embodiment of the present invention is in a range from about 6 μm to 6.5 μm , the ratio **d1/d2** of the width **d1** of the minute branches **194a**, **194b**, **194c**, **194d** to the interval **d2** between respective neighboring minute branches **194a**, **194b**, **194c**, **194d** may be in a range from about 1.2 to 1.35. Also, when the sum of the width **d1** of the minute branches **194a**, **194b**, **194c**, **194d** and the interval **d2** between respective neighboring minute branches **194a**, **194b**, **194c**, **194d** is in a range from about 6.5 μm to 7 μm , the ratio **d1/d2** of the width **d1** of the minute branches **194a**, **194b**, **194c**, **194d** to the interval **d2** between respective neighboring minute branches **194a**, **194b**, **194c**, **194d** may be in a range from about 1.35 to 1.5. Further, when the sum of the width **d1** of the minute branches **194a**, **194b**, **194c**, **194d** and the interval **d2** between respective neighboring minute branches **194a**, **194b**, **194c**, **194d** is in a range from about 5 μm to 6 μm , the ratio **d1/d2** of the width **d1** of the minute branches **194a**, **194b**, **194c**, **194d** to the interval **d2** between respective neighboring minute branches **194a**, **194b**, **194c**, **194d** may be in a range from about 1.05 to 1.2. In addition, when the sum of the width **d1** of the minute branches **194a**, **194b**, **194c**, **194d** and the interval **d2** between respective neighboring minute branches **194a**, **194b**, **194c**, **194d** is greater than 7 μm , the ratio **d1/d2** of the width **d1** of the minute branches **194a**, **194b**, **194c**, **194d** to the interval **d2** between the respective neighboring minute branches **194a**, **194b**, **194c**, **194d** may be greater than 1.5.

Again, referring to FIG. 2, FIG. 3, FIG. 4 and FIG. 5, the first subpixel electrode **191a** includes one basic electrode **199**. The transverse stem **193** of the basic electrode **199** forming the first subpixel electrode **191a** expands downward and upward to form a first expansion **193a**, and the first expansion **193a** overlaps the first storage electrode **133a**. Also, a protrusion that protrudes downward for easy contact with the first drain electrode **175a** is formed in the center of the downward edge of the first expansion **193a**.

The second subpixel electrode **191b** includes an upper electrode **191bu** and a lower electrode **191bb**, and the upper electrode **191bu** and the lower electrode **191bb** each include one basic electrode **199**. The upper electrode **191bu** and the lower electrode **191bb** are connected to each other through a left connection **195a** and a right connection **195b**.

The second subpixel electrode **191b** encloses the first subpixel electrode **191a** with the gap **91** therebetween. A portion of the center of the transverse stem of the lower electrode **191bb** extends upward and downward to form a second expansion **193bb** overlapping the second storage electrode **133b**. Also, a protrusion that protrudes downward for easy contact with the second drain electrode **175b** is formed in the center of the downward edge of the second expansion **193bb**.

The area of the second subpixel electrode **191b** may be about 1.0 to 2.2 times the area of the first subpixel electrode **191a**.

Each first subpixel electrode **191a** and second subpixel electrode **191b** is physically and electrically connected to the respective first drain electrode **175a** and second drain electrode **175b** through the respective contact holes **185a** and **185b**, and receives data voltages from the respective first drain electrode **175a** and second drain electrode **175b**.

On the other hand, the upper electrode **191bu** may be directly applied with the data voltages from the second drain electrode **175b**. In this case, the second drain electrode **175b** extends to the upper electrode **191bu**, and a contact hole (not shown) for contact of the upper electrode **191bu** and the second drain electrode **175b** is required. In this case, the left and right connections **195a** and **195b** are not necessary.

An alignment layer **11** is formed on the pixel electrodes **191**.

Next, the upper panel **200** will be described.

The common electrode **270** is formed on an insulating substrate **210**, and an alignment layer **21** is formed thereon.

Each of the alignment layers **11** and **21** may be a vertical alignment layer.

Finally, polarizers (not shown) may be provided on the outer surface of the display panels **100** and **200**.

The liquid crystal layer **3** interposed between the lower panel **100** and the upper panel **200** includes liquid crystal molecules **310** and polymers **350** and **370** having negative dielectric anisotropy (see FIG. 7).

The liquid crystal molecules **310** are pretilted by the polymers **350** and **370** for the long axis thereof to be about parallel to the length direction of respective first minute branches **194a**, second minute branches **194b**, third minute branches **194c** and fourth minute branches **194d** of the first subpixel electrode **191a** and the second subpixel electrode **191b**. The liquid crystal molecules **310** are aligned vertically with respect to the surfaces of the two display panels **100** and **200**. Accordingly, the first and second subpixels **PXa** and **PXb** respectively include four subregions **Da**, **Db**, **Dc** and **Dd** having different pretilt directions of the liquid crystal.

If the gate lines **121** are applied with the gate signals, the data voltage is applied to the first subpixel electrodes **191a** and the second subpixel electrodes **191b** through the data lines **171a** and **171b**. Then, the first subpixel electrodes **191a** and the second subpixel electrodes **191b** applied with the data voltage and the common electrode **270** applied with the common voltage generate an electric field to the liquid crystal layer **3**. Accordingly, the liquid crystal molecules **310** of the liquid crystal layer **3** are arranged in response of the electric field such that the major axes of the liquid crystal molecules **310** tend to change the direction to be perpendicular to the direction of the electric field. The inclination degree of the liquid crystal molecules **310** changes the degree of polarization of light incident to the liquid crystal layer **3**. The change in degree of polarization is proportional to the inclination degree of the liquid crystal molecules **310**, and this change of the incident light polarization is represented with a change of transmittance by a polarizer, and thereby a liquid crystal display displays an image.

On the other hand, the edges of the minute branches **194a**, **194b**, **194c**, **194d** distort the electric field to make horizontal components of the electric field perpendicular to the edges of the minute branches **194a**, **194b**, **194c**, **194d**, and the inclination direction of the liquid crystal molecules **310** is determined in the direction determined by the horizontal components of the electric field. Accordingly, the liquid crystal molecules **310** firstly tend to tilt in the direction perpendicular

to the edges of the minute branches **194a**, **194b**, **194c**, **194d**. However, the directions of the horizontal components of the electric field by the respective neighboring minute branches **194a**, **194b**, **194c**, **194d** are opposite to each other and the intervals **d2** between the respective minute branches **194a**, **194b**, **194c**, **194d** are narrow such that the liquid crystal molecules **310** which tend to arrange in the opposite directions are tilted in the direction parallel to the length direction of the minute branches **194a**, **194b**, **194c**, **194d**. Accordingly, as the exemplary embodiment of the present invention, if the liquid crystal molecules **310** are initially not pretilted in the length direction of the minute branches **194a**, **194b**, **194c**, **194d**, the liquid crystal molecules **310** are tilted in the length direction of the minute branches **194a**, **194b**, **194c**, **194d** through two steps. However, in the present exemplary embodiment, the liquid crystal molecules **310** are already pretilted in the direction parallel to the length direction of the minute branches **194a**, **194b**, **194c**, **194d** such that the liquid crystal molecules **310** are not tilted in the direction parallel to the length direction of the minute branches **194a**, **194b**, **194c**, **194d** through two steps, but are tilted in the pretilted direction through one step. Therefore, if the liquid crystal molecules **310** are provided to have the pretilt, they are tilted in the required direction one time such that the response speed of the liquid crystal display may be improved.

Also, in an exemplary embodiment of the present invention, the length directions in which the minute branches **194a**, **194b**, **194c**, **194d** are extended in one pixel **PX** are all four directions such that the inclined directions of the liquid crystal molecules **310** are in all four directions. Therefore, the viewing angle of the liquid crystal display is widened by varying the inclined directions of the liquid crystal molecules **310**.

On the other hand, the transmittance of the liquid crystal display is increased with the increasing of the width **d1** of the first minute branches **194a**, the second minute branches **194b**, the third minute branches **194c** and the fourth minute branches **194d** and the decreasing of the interval **d2** between respective neighboring minute branches **194a**, **194b**, **194c**, **194d** within respective subregions **Da**, **Db**, **Dc** and **Dd**, however if the interval **d2** between respective neighboring first minute branches **194a**, second minute branches **194b**, third minute branches **194c** and fourth minute branches **194d** is excessively large compared with the width **d1** of the minute branches **194a**, **194b**, **194c**, **194d**, it is difficult for the liquid crystal molecules to be inclined in the direction parallel to the length direction of the minute branches **194a**, **194b**, **194c**, **194d**. Accordingly, the width **d1** of the first minute branches **194a**, the second minute branches **194b**, the third minute branches **194c** and the fourth minute branches **194d** and the interval **d2** between respective neighboring minute branches **194a**, **194b**, **194c**, **194d** are controlled to increase the transmittance of the liquid crystal display while controlling the liquid crystal molecules **310** to be inclined in the length direction of the minute branches **194a**, **194b**, **194c**, **194d** such that the transmittance of the liquid crystal display may be increased.

As above-described, in the liquid crystal display according to an exemplary embodiment of the present invention, when the sum of the width **d1** of the minute branches **194a**, **194b**, **194c**, **194d** and the interval **d2** between respective neighboring minute branches **194a**, **194b**, **194c**, **194d** is in the range from about $6\ \mu\text{m}$ to $6.5\ \mu\text{m}$, the ratio $d1/d2$ may be in the range from about 1.2 to 1.35, when the sum of the width **d1** and the interval **d2** is in the range from about $6.5\ \mu\text{m}$ to $7\ \mu\text{m}$, the ratio $d1/d2$ may be in the range from about 1.35 to 1.5, when the sum of the width **d1** and the interval **d2** is in the range from

about $5\ \mu\text{m}$ to $6\ \mu\text{m}$, the ratio $d1/d2$ may be in the range from about 1.05 to 1.2, and when the sum of the width **d1** and the interval **d2** is greater than $7\ \mu\text{m}$, the ratio $d1/d2$ may be greater than 1.5. As above-described, the width **d1** of the minute branches **194a**, **194b**, **194c**, **194d** is wider than the interval **d2** between the respective neighboring minute branches **194a**, **194b**, **194c**, **194d**, and the ratio $d1/d2$ of the width **d1** to the interval **d2** is controlled according to the sum of the width **d1** and the interval **d2** such that the transmittance of the liquid crystal display may be increased while inclining the liquid crystal molecule in the length direction of the minute branches **194a**, **194b**, **194c**, **194d**.

The first sub-pixel electrode **191a** and the common electrode **270** form the first liquid crystal capacitor **Clca** and the second sub-pixel electrode **191b** and the common electrode **270** form the second liquid crystal capacitor **Clcb** to maintain an applied voltage even after the TFT is turned off. Also, the first storage electrode **133a** and the second storage electrode **133b** of the storage electrode line **131** respectively overlap the first subpixel electrode **191a** and the second subpixel electrode **191b** in the openings **233a** and **233b** to form the storage capacitors **Csta** and **Cstb**.

The hook-shaped portion **135** of the storage electrode line **131** overlaps the gap **91** of the pixel electrode **191** such that it functions as a shielding member for blocking the light leakage between the first subpixel electrode **191a** and the second subpixel electrode **191b**. The hook-shaped portion **135** disposed between the data lines **171a** and **171b** and the first subpixel electrode **191a** prevents crosstalk to thereby reduce the degradation of the display quality.

Also, in the structure of pixel electrode **191** in an exemplary embodiment of the present invention, the direction of the liquid crystal molecules **310** is not controlled near the longitudinal and transverse stems of the first subpixel electrode **191a** and the second subpixel electrode **191b** such that texture may be generated. Accordingly, the storage electrode line **131**, the longitudinal portion **137** of the storage electrode line **131**, the first storage electrode **133a** and the second storage electrode **133b** overlap the transverse stem or the longitudinal stem of the first subpixel electrode **191a** and the second subpixel electrode **191b** such that the texture may be covered, and so the aperture ratio may be simultaneously increased.

On the other hand, the first subpixel electrode **191a** and the second subpixel electrode **191b** are applied with different data voltages through the different data lines **171a** and **171b**, and the voltage of the first subpixel electrode **191a** having the relatively smaller area is higher than the voltage of the second subpixel electrode **191b** having the relatively larger area.

In this way, when the voltages of the first sub-pixel electrode **191a** and the second sub-pixel electrode **191b** are different from each other, the voltage applied to the first liquid crystal capacitor **Clca** formed between the first sub-pixel electrode **191a** and the common electrode **270** and the voltage applied to the second liquid crystal capacitor **Clcb** formed between the second sub-pixel electrode **191b** and the common electrode **270** are different from each other such that the declination angle of the liquid crystal molecules of the subpixels **PXa** and **PXb** are different from each other, and as a result the luminance of the two subpixels become different. Accordingly, if the voltages of the first liquid crystal capacitor **Clca** and the second liquid crystal capacitor **Clcb** are appropriately controlled, the images shown at the side of the liquid crystal display may be approximate to the images shown at the front of the liquid crystal display, that is to say, the gamma curve of the side may be approximately close to the gamma curve of the front, thereby improving the side visibility.

Also, in an exemplary embodiment of the present invention, when the first subpixel electrode **191a** applied with the higher voltage is disposed in the central part of the pixel PX, and the first subpixel electrode **191a** is farther apart from gate line **121** such that an overlapping portion therebetween is not generated, kick-back voltage is reduced and flicker is removed.

Next, the initial alignment method for providing a pretilt angle to liquid crystal molecules **310** will be described with reference to FIG. 7.

FIG. 7 is a view showing a process of providing a pretilt angle to liquid crystal molecules by using prepolymers that are polarized by light such as ultraviolet rays.

Prepolymers **330** such as monomers that are hardened through polymerization by light such as ultraviolet rays are inserted between two display panels **100** and **200** along with the liquid crystal material. The prepolymers **330** may be a reactive mesogen that is polymerized by light such as ultraviolet rays.

Next, the first subpixel electrode **191a** and the second subpixel electrode **191b** are applied with the data voltages and the common electrode **270** of the upper panel **200** is applied with the common voltage to generate an electric field to the liquid crystal layer **3** between the two display panels **100** and **200**. Thus, the liquid crystal molecules **310** of the liquid crystal layer **3** are inclined in the direction parallel to the length direction of the minute branches **194a**, **194b**, **194c**, **194d** through two steps as above-described in response to the electric field, and the liquid crystal molecules **310** in one pixel PX are inclined in a total of four directions.

If the light such as ultraviolet rays is irradiated after the application of the electric field to the liquid crystal layer **3**, the prepolymers **330** are polymerized such that a first polymer **350** and a second polymer **370** are formed as shown in FIG. 7.

The first polymer **350** is formed in the liquid crystal layer **3**, and the second polymer **370** is formed close to the display panels **100** and **200**. The alignment direction is determined for the liquid crystal molecules **310** to have the pretilt in the length direction of the minute branches **194a**, **194b**, **194c**, **194d** by the first polymer **350** and the second polymer **370**.

Accordingly, the liquid crystal molecules **310** are arranged with the pretilts of four different directions under non-application of the voltage to the electrodes **191** and **270**.

Next, another exemplary embodiment of the present invention will be described with the reference to FIG. 8, FIG. 9 and FIG. 10.

FIG. 8 is a layout view of a liquid crystal display according to another exemplary embodiment of the present invention, FIG. 9 is a top plan view of a pixel electrode of the liquid crystal display shown in FIG. 8, and FIG. 10 is an enlarged view of portion A' of the basic electrode shown in FIG. 9.

The layered structure of the liquid crystal display according to the present exemplary embodiment is almost the same as the layered structure of the liquid crystal display shown in FIG. 2, FIG. 3 and FIG. 4. Hereafter, different characteristics from the previously described exemplary embodiment will be mainly described.

Referring to FIG. 8, FIG. 9 and FIG. 10, the storage electrode line **131** includes a left longitudinal portion **135a** and a right longitudinal portion **135b** extending downward from the storage electrode line **131**, and a storage electrode **133** protruding in the right direction from the left longitudinal portion **135a**. The storage electrode **133** has a wider width than that of the other portions of the storage electrode line **131** for overlapping with a pixel electrode **191** to be described later.

The first drain electrode **175a** includes one end having a wide area lengthily extending upward, and the second drain electrode **175b** includes one end having a wide area shortly extending upward.

The color filters (not shown) have through holes (not shown) where contact holes **185a** and **185b** are passed through and an opening **233** disposed on the storage electrode **133**, and an upper passivation layer (not shown) and a lower passivation layer (not shown) have a plurality of contact holes **185a** and **185b** exposing the first drain electrodes **175a** and the second drain electrode **175b**, respectively.

The pixel electrode **191** according to the present exemplary embodiment also includes the first subpixel electrodes **191a** and the second subpixel electrode **191b** that are separated from each other by a gap **91** of a quadrangular belt shape therebetween, like the exemplary embodiment show in FIG. 2, FIG. 3 and FIG. 4.

The first subpixel electrode **191a** is made of one basic electrode **199** shown in FIG. 5. A transverse stem of the first subpixel electrode **191a** is expanded upward and downward to form an expansion **193a**, and the expansion **193a** overlaps the storage electrode **133** in an opening **233** to form a storage capacitor Csta.

The second subpixel electrode **191b** includes one basic electrode **199**, and a connection bridge **195** enclosing the first subpixel electrode **191a**, which is disposed below with the gap **91** interposed therebetween.

The left lower portion of the connection bridge **195** is protruded in the right direction with a wide area for contact with the second drain electrode **175b**. As shown in FIG. 8, the second subpixel electrode **191b** receives data voltages from the second drain electrode **175b** through the connection bridge **195**.

The lower transverse edge of the connection bridge **195** overlaps a portion of the gate line **121** to prevent the first subpixel electrode **191a** from being influenced by the gate signals of the gate lines **121**.

Both longitudinal edges of the connection bridge **195** cover the data lines **171a** and **171b** for preventing crosstalk between the data signal and the first subpixel electrode **191a**.

The width of the connection bridge **195** may be in a range from 5.0 μm to 15 μm .

The storage electrode line **131** overlaps the gap **91** of the pixel electrode **191** to block light leakage between the first subpixel electrode **191a** and the second subpixel electrode **191b**. Also, the right longitudinal portion **135a** and the left longitudinal portion **135b** of the storage electrode line **131** are disposed between the first subpixel electrode **191a** and the data lines **171a** and **171b**, to prevent crosstalk between the data lines **171a** and **171b** and the first subpixel electrode **191a**.

The area of the second subpixel electrode **191b** may be in a range from about 1.25 to 2.75 times the area of the first subpixel electrode **191a**.

Differently from the above-described exemplary embodiment, according to the present exemplary embodiment, the first drain electrode **175a** and the second drain electrode **175b** do not overlap the second subpixel electrode **191b** and the first subpixel electrode **191a** applied with data voltages of different polarities, but overlap the first subpixel electrode **191a** and the second subpixel electrode **191b** applied with data voltages of the same polarity such that the texture caused by the distortion of the electric field is not generated near the first drain electrode **175a** and the second drain electrode **175b** even though the first data line **171a** and the second data line **171b** are applied with data voltages of opposite polarities.

Accordingly, according to the present exemplary embodiment, the texture may be prevented, thereby increasing the transmittance.

Also, according to the present exemplary embodiment, the contact holes **185a** and **185b** are disposed on the edges or corners of the first subpixel PXa and the second subpixel PXb such that it is easy to form color filters (not shown) by an inkjet process.

Like the above-described exemplary embodiment, the liquid crystal molecules are inclined in the four directions in the case of the present exemplary embodiment such that the viewing angle of the liquid crystal display may be increased, and the liquid crystal molecules have the pretilt through the polymerization of the prepolymer such that the response speed may be improved. Also, the first subpixel electrode **191a** and the second subpixel electrode **191b** are applied with different data voltages, thereby improving the side visibility.

As shown in FIG. 10, in the liquid crystal display according to the present exemplary embodiment, when the sum of the width **d1** of the minute branches **194a**, **194b**, **194c**, **194d** and the interval **d2** between the respective neighboring minute branches **194a**, **194b**, **194c**, **194d** is in the range from about 6 μm to 6.5 μm , the ratio **d1/d2** may be in the range from about 1.2 to 1.35, when the sum of the width **d1** and the interval **d2** is in the range from about 6.5 μm to 7 μm , the ratio **d1/d2** may be in the range from about 1.35 to 1.5, when the sum of the width **d1** and the interval **d2** is in the range from about 5 μm to 6 μm , the ratio **d1/d2** may be in the range from about 1.05 to 1.2, and when the sum of the width **d1** and the interval **d2** is greater than 7 μm , the ratio **d1/d2** may be greater than 1.5. As above-described, the width **d1** of the minute branches **194a**, **194b**, **194c**, **194d** is wider than the interval **d2** between the respective neighboring minute branches **194a**, **194b**, **194c**, **194d**, and the ratio **d1/d2** of the width **d1** of the minute branches **194a**, **194b**, **194c**, **194d** to the interval **d2** between the respective neighboring minute branches **194a**, **194b**, **194c**, **194d** is controlled according to the sum of the width **d1** of the minute branches **194a**, **194b**, **194c**, **194d** and the interval **d2** between the respective neighboring minute branches **194a**, **194b**, **194c**, **194d** such that the transmittance of the liquid crystal display may be increased while inclining the liquid crystal molecule in the length direction of the minute branches **194a**, **194b**, **194c**, **194d**.

Next, another exemplary embodiment of the present invention will be described with reference to FIG. 11 and FIG. 12.

FIG. 11 is a layout view of a liquid crystal display according to another exemplary embodiment of the present invention, and FIG. 12 is a top plan view of a pixel electrode of the liquid crystal display shown in FIG. 11.

A liquid crystal display according to the present exemplary embodiment is almost the same as the liquid crystal display shown in FIG. 8 to FIG. 10. Hereafter, different characteristics from the previously described exemplary embodiment will be mainly described.

Referring to FIG. 11 and FIG. 12, the wide end portion of the first drain electrode **175a** to apply the data voltage to the first subpixel electrode **191a** is disposed at the right lower corner of the first subpixel PXa, and is electrically and physically connected to the first subpixel electrode **191a** through the contact hole **185a**. Accordingly, when forming the color filter (not shown) through an inkjet process, the process may be easily executed and the transmittance may be improved.

Also, the storage electrodes and the openings having the wide area for forming the storage capacitors Csta and Cstb do not exist in the present exemplary embodiment, thereby increasing the aperture ratio.

As above-described, in the liquid crystal display according to the present exemplary embodiment, when the sum of the width **d1** of the minute branches **194a**, **194b**, **194c**, **194d** and the interval **d2** between the respective neighboring minute branches **194a**, **194b**, **194c**, **194d** is in the range of about 6 μm to 6.5 μm , the ratio **d1/d2** may be in the range from about 1.2 to 1.35. When the sum of the width **d1** and the interval **d2** is in the range from about 6.5 μm to 7 μm , the ratio **d1/d2** may be in the range from about 1.35 to 1.5. When the sum of the width **d1** and the interval **d2** is in the range from about 5 μm to 6 μm , the ratio **d1/d2** may be in the range from about 1.05 to 1.2, and when the sum of the width **d1** and the interval **d2** is greater than 7 μm , the ratio **d1/d2** may be greater than 1.5. Accordingly, the width **d1** of the minute branches **194a**, **194b**, **194c**, **194d** is wider than the interval **d2** between the respective neighboring minute branches **194a**, **194b**, **194c**, **194d**, and the ratio **d1/d2** of the width **d1** of the minute branches **194a**, **194b**, **194c**, **194d** to the interval **d2** of the respective neighboring minute branches **194a**, **194b**, **194c**, **194d** is controlled according to the sum of the width **d1** of the minute branches **194a**, **194b**, **194c**, **194d** and the interval **d2** between the respective neighboring minute branches **194a**, **194b**, **194c**, **194d** such that the transmittance of the liquid crystal display may be increased while inclining the liquid crystal molecule in the length direction of the minute branches **194a**, **194b**, **194c**, **194d**.

Next, another exemplary embodiment of the present invention will be described with reference to FIG. 13 and FIG. 14.

FIG. 13 is a layout view of a liquid crystal display according to another exemplary embodiment of the present invention, and FIG. 14 is a top plan view of a pixel electrode of the liquid crystal display shown in FIG. 13.

The layered structure of the liquid crystal display according to the present exemplary embodiment is almost the same as the layered structure of the liquid crystal display shown in FIG. 2 to FIG. 4. Hereafter, different characteristics from the previously described exemplary embodiment will be mainly described.

Referring to FIG. 13 and FIG. 14, the storage electrode line **131** includes a left longitudinal portion **135a** and a right longitudinal portion **135b** extending upward and downward from the storage electrode line **131**, a transverse connection **132** connected between the two longitudinal portions **135a** and **135b**, and a storage electrode **133** protruding from the center of the transverse connection **132** to the lower direction and having a wide area.

The color filters (not shown) have through holes (not shown) where contact holes **185a** and **185b** are passed through and an opening **233** disposed on the storage electrode **133**, and an upper passivation layer (not shown) and a lower passivation layer (not shown) have a plurality of contact holes **185a** and **185b** exposing the first and second drain electrodes **175a** and **175b**.

The pixel electrode **191** also includes the first subpixel electrode **191a** and second subpixel electrode **191b** that are separated from each other by a gap **91** of a quadrangular belt shape therebetween.

The first subpixel electrode **191a** is made of one basic electrode **199** shown in FIG. 5. The lower portion of the longitudinal stem of the first subpixel electrode **191a** is extended left and right to form an expansion **192a**, and the expansion **192a** overlaps the storage electrode **133** in the opening **233** to form a storage capacitor Csta.

The second subpixel electrode **191b** includes an upper electrode **191bu** and a lower electrode **191bb**, and the upper electrode **191bu** and the lower electrode **191bb** are connected through a left connection **195a** and a right connection **195b**.

Two longitudinal portions of the storage electrode line **131** overlap the gap **91** such that they block light leakage between the first subpixel electrode **191a** and the second subpixel electrode **191b** and prevent crosstalk between the first subpixel electrode **191a** and the data lines **171a** and **171b**. Also, the transverse connection **132** of the storage electrode line **131** covers the texture near the transverse stem **193a** of the first subpixel electrode **191a**, thereby improving the aperture ratio.

As above-described, in the liquid crystal display according to the present exemplary embodiment, when the sum of the width **d1** of the minute branches **194a**, **194b**, **194c**, **194d** and the interval **d2** between the respective neighboring minute branches **194a**, **194b**, **194c**, **194d** is in the range from about 6 μm to 6.5 μm , the ratio **d1/d2** may be in the range from about 1.2 to 1.35. When the sum of the width **d1** and the interval **d2** is in the range from about 6.5 μm to 7 μm , the ratio **d1/d2** may be in the range from about 1.35 to 1.5. When the sum of the width **d1** and the interval **d2** is in the range from about 5 μm to 6 μm , the ratio **d1/d2** may be in the range from about 1.05 to 1.2, and when the sum of the width **d1** and the interval **d2** is greater than 7 μm , the ratio **d1/d2** may be greater than 1.5. Also, the width **d1** of the minute branches **194a**, **194b**, **194c**, **194d** is wider than the interval **d2** between the respective neighboring minute branches **194a**, **194b**, **194c**, **194d**, and the ratio **d1/d2** of the width **d1** of the minute branches **194a**, **194b**, **194c**, **194d** to the interval **d2** of the respective neighboring minute branches **194a**, **194b**, **194c**, **194d** is controlled according to the sum of the width **d1** of the minute branches **194a**, **194b**, **194c**, **194d** and the interval **d2** between the respective neighboring minute branches **194a**, **194b**, **194c**, **194d** such that the transmittance of the liquid crystal display may be increased while inclining the liquid crystal molecule in the length direction of the minute branches **194a**, **194b**, **194c**, **194d**.

In the present exemplary embodiment, differently from the exemplary embodiment shown in FIG. 2, FIG. 3 and FIG. 4, a transverse stem **193bu** of the upper electrode **191bu** is not disposed on the central part of the upper electrode **191bu**, but is proximate the upper edge, and the transverse stem **193bb** of the lower electrode **191bb** is disposed proximate the lower edge of the lower electrode **191bb**. Accordingly, two of the subregions among the four subregions Da, Db, Dc, Dd of the basic electrode **199** of FIG. 5 as above-described almost disappear under the upper electrode **191bu** and the lower electrode **191bb**, and remain dummies. However, the subregions Da, Db, Dc, Dd of four directions still exist in the second subpixel electrode **191b** such that the inclined direction of the liquid crystal molecules **310** may be various.

In this case, the area of the two remaining subregions Dc and Dd of the upper electrode **191bu** may be greater than 1.5 times the area of the two subregions Da and Db that become small. The area of the two remaining subregions Da and Db of the lower electrode **191bb** may be greater than 1.5 times the area of the two subregions Dc and Dd that become small.

Also, the width in the upper and lower direction of the two subregions Da and Db of the upper electrode **191bu** and the two subregions Dc and Dd of the lower electrode **191bb** may be about 5 μm .

Like the present exemplary embodiment, two subregions Da and Db of the upper electrode **191bu** or two subregions Dc and Dd of the lower electrode **191bb** overlap the gate line **121** as the dummy shape such that the aperture ratio and the transmittance may be increased and the texture may be covered near the transverse stems **193bu** and **193bb**.

In the present exemplary embodiment, as in the previously-described exemplary embodiment, the liquid crystal mol-

ecules are inclined in four directions such that the viewing angle of the liquid crystal display may be increased, and the liquid crystal molecules are pretilted through the polymerization of the prepolymer to thereby improve the response speed. Also, the first and second subpixel electrodes **191a** and **191b** are applied with different data voltages to thereby improve the side visibility.

Differently from an exemplary embodiment of the present invention, a light alignment method in which light such as ultraviolet rays is obliquely irradiated to the alignment layers **11** and **21** may be used to control the alignment direction and the alignment angle of the liquid crystal molecules **310** as a means for forming a plurality of subregions Da, Db, Dc, Dd where the liquid crystal molecules **310** are inclined in the different directions. In this case, the minute branches **194a**, **194b**, **194c**, **194d** of the pixel electrodes **191** are not necessary such that the aperture ratio may be increased and the response time may be improved by the pretilt of the liquid crystal molecule **310** that is generated by the light alignment.

Next, the transmittance of the liquid crystal display changed according to the sum of the width **d1** of the minute branches **194a**, **194b**, **194c**, **194d** and the interval **d2** between the respective neighboring minute branches **194a**, **194b**, **194c**, **194d**, and the ratio **d1/d2** of the width **d1** of the minute branches **194a**, **194b**, **194c**, **194d** to the interval **d2** of the respective neighboring minute branches **194a**, **194b**, **194c**, **194d** will be described with reference to FIG. 15 in one experimental example of the present invention. FIG. 15 is a graph showing a transmittance result of a liquid crystal display according to one experimental example of the present invention.

Generally, factors applied to influence the transmittance of the liquid crystal display may be divided into a first factor, a second factor, and a third factor. The first factor is the shape of the signal lines such as the gate line or the data line and the shape of the constituent elements that block the light such as the black matrix. The first factor is the main factor changing the aperture ratio of the liquid crystal display. The second factor is the size of a cell gap, a dielectric rate of the liquid crystal, and the applied voltage. The cell gap is the gap between the upper panel **200** and the lower panel **100** filled in with the liquid crystal layer **3**. Generally, when the cell gap, the dielectric rate of the liquid crystal, or the applied voltage is increased, the transmittance of the liquid crystal display is increased. Finally, the third factor is the structure of the pixel itself that is largely applied to the change of the transmittance of the liquid crystal display in the case of the vertical alignment liquid crystal display. Among these three factors, the first factor and the second factor may greatly influence the different constituent elements of the liquid crystal display such that change of the first factor and the second factor is difficult, however the third factor is changed according to the design of the pixel electrode such that the change is relatively easy. Also, it is possible for the transmittance of the liquid crystal display to be changed in the range of about 10% to 15% by the third factor.

In the present experimental example, in the state in which the various conditions such as the cell gap of the liquid crystal display, the physical characteristic of the liquid crystal layer, and the driving voltage are all the same, the transmittance of the liquid crystal display is measured as shown in FIG. 15 while changing the sum (**d1+d2**) of the width **d1** of the minute branches **194a**, **194b**, **194c**, **194d** and the interval **d2** between the respective neighboring minute branches **194a**, **194b**, **194c**, **194d**, and the ratio **d1/d2** of the width **d1** of the minute

branches **194a**, **194b**, **194c**, **194d** to the interval **d2** between the respective neighboring minute branches **194a**, **194b**, **194c**, **194d**.

Referring to FIG. **15**, as the sum **d1+d2** is increased, it may be confirmed that the ratio **d1/d2** that has the high transmittance is increased.

Also, referring to FIG. **15**, it may be confirmed that when the sum **d1+d2** is about $6.0\ \mu\text{m}$, and the ratio **d1/d2** is about 1.28, the transmittance of the liquid crystal display is highest, when the sum **d1+d2** is about $6.5\ \mu\text{m}$, and the ratio **d1/d2** is about 1.42, the transmittance of the liquid crystal display is highest, and when the sum **d1+d2** is about $7.0\ \mu\text{m}$, and the ratio **d1/d2** is about 1.45, the transmittance of the liquid crystal display is highest. Accordingly, it may be confirmed that as the sum **d1+d2** of the width **d1** of the minute branches **194a**, **194b**, **194c**, **194d** and the interval **d2** between the respective minute branches **194a**, **194b**, **194c**, **194d** is increased, and when the ratio **d1/d2** of the width **d1** of the minute branches **194a**, **194b**, **194c**, **194d** to the interval **d2** between the respective neighboring minute branches **194a**, **194b**, **194c**, **194d** is increased, the transmittance of the liquid crystal display is increased.

Also, referring to the graph of FIG. **15**, like the liquid crystal display according to an exemplary embodiment of the present invention, when the sum **d1+d2** is about $6\ \mu\text{m}$ to $6.5\ \mu\text{m}$, the ratio **d1/d2** is about 1.2 to 1.35, when the sum **d1+d2** is about $6.5\ \mu\text{m}$ to $7\ \mu\text{m}$, the ratio **d1/d2** about 1.35 to 1.5, when the sum **d1+d2** is about $6\ \mu\text{m}$, the ratio **d1/d2** is in the range from about 1.05 to 1.2, and when the sum **d1+d2** is greater than $6\ \mu\text{m}$, the ratio **d1/d2** is greater than 1.5, the transmittance is decreased by 10% to 20% compared with the maximum transmittance.

According to the liquid crystal display of an exemplary embodiment of the present invention, the pixel electrode may be formed for the width **d1** of the minute branches **194a**, **194b**, **194c**, **194d** to be wider than the interval **d2** between the respective minute branches **194a**, **194b**, **194c**, **194d**, and to have the ratio **d1/d2** of the width **d1** of the minute branches **194a**, **194b**, **194c**, **194d** to the interval **d2** between the respective neighboring minute branches **194a**, **194b**, **194c**, **194d** according to the sum of the width **d1** of the minute branches **194a**, **194b**, **194c**, **194d** and the interval **d2** between the respective neighboring minute branches **194a**, **194b**, **194c**, **194d** for the high transmittance pixel electrode such that it is controlled that the liquid crystal molecules are inclined in the length direction of the minute branches **194a**, **194b**, **194c**, **194d** and the transmittance of the liquid crystal display may be increased.

It will be apparent to those skilled in the art that various modifications and variations can be made in the present invention without departing from the spirit or scope of the invention. Thus, it is intended that the present invention cover the modifications and variations of this invention provided they come within the scope of the appended claims and their equivalents.

What is claimed is:

1. A liquid crystal display comprising:

a pixel electrode comprising a first subpixel electrode and a second subpixel electrode with a gap therebetween; a common electrode facing the pixel electrode; and a liquid crystal layer disposed between the pixel electrode and the common electrode, and comprising a plurality of liquid crystal molecules, wherein the first subpixel electrode and the second subpixel electrode include a plurality of minute branches,

the first subpixel electrode and the second subpixel electrode comprise a plurality of subregions having different length directions of the minute branches,

a width of each of the minute branches is wider than an interval between neighboring minute branches, and a sum of the width **d1** of each of the minute branches and the interval **d2** between the neighboring minute branches is in a range from about $5\ \mu\text{m}$ to $7\ \mu\text{m}$,

when the sum of the width **d1** of each of the minute branches and the interval **d2** between the neighboring minute branches is in a range from $6\ \mu\text{m}$ to $6.5\ \mu\text{m}$, a ratio **d1/d2** of the width **d1** to the interval **d2** is in a range from 1.2 to 1.35,

when the sum of the width **d1** of each of the minute branches and the interval **d2** between the neighboring minute branches is in a range from $6.5\ \mu\text{m}$ to $7\ \mu\text{m}$, the ratio **d1/d2** is in a range from 1.35 to 1.5, and

when the sum of the width **d1** of each of the minute branches and the interval **d2** between the neighboring minute branches is in a range from $5\ \mu\text{m}$ to $6\ \mu\text{m}$, the ratio **d1/d2** is in a range from 1.05 to 1.2.

2. The liquid crystal display of claim 1, wherein the liquid crystal molecules are aligned with a pretilt along the length direction of the minute branches.

3. The liquid crystal display of claim 2, wherein the liquid crystal layer further comprises polymers to pretilt the liquid crystal molecules, and the polymers are formed by irradiating ultraviolet rays to prepolymers of monomers.

4. The liquid crystal display of claim 1, further comprising an alignment layer formed on the pixel electrode or the common electrode,

wherein the alignment layer is light-aligned along the length direction of the minute branches.

5. The liquid crystal display of claim 1, wherein the first subpixel electrode and the second subpixel electrode further comprise a transverse stem and a longitudinal stem forming a boundary of the subregions, and the minute branches of the first subpixel electrode and the second subpixel electrode start from the transverse stem or the longitudinal stem and extend toward edges of the first subpixel electrode and the second subpixel electrode, respectively.

6. The liquid crystal display of claim 1, wherein the voltage of the first subpixel electrode is higher than the voltage of the second subpixel electrode.

7. The liquid crystal display of claim 6, wherein the first subpixel electrode and the second subpixel electrode are applied with different data voltages provided from information of one image.

8. The liquid crystal display of claim 1, wherein at least one of the first subpixel electrode and the second subpixel electrode further comprises four subregions having different length directions of the minute branches.

9. The liquid crystal display of claim 8, wherein the areas of the four subregions are different from each other in the first subpixel electrode or the second subpixel electrode.

10. The liquid crystal display of claim 8, wherein at least one of the first subpixel electrode and the second subpixel electrode further comprises a transverse stem and a longitudinal stem forming the boundaries of the four subregions.

11. The liquid crystal display of claim 10, wherein the area of two subregions disposed at a left side or a right side with respect to the longitudinal stem of the first

19

subpixel electrode or the second subpixel electrode is 1.5 times greater than the area of the remaining two subregions disposed at the opposite side with respect to the longitudinal stem.

12. The liquid crystal display of claim 1, wherein the second subpixel electrode further comprises an upper electrode disposed above the first subpixel electrode, and a lower electrode disposed below the first subpixel electrode.

13. The liquid crystal display of claim 1, wherein the second subpixel electrode further comprises a connection disposed at the left side or the right side of the first subpixel electrode and connecting an upper electrode and a lower electrode of the second subpixel, wherein the upper electrode is disposed above the first subpixel electrode, and the lower electrode is disposed below the first subpixel electrode.

14. The liquid crystal display of claim 13, further comprising:
a first signal line and a second signal line;
a third signal line and a fourth signal line crossing the first signal line and the second signal line;
a first switching element connected to the first signal line and the third signal line to transmit a data voltage from the third signal line to the first subpixel electrode; and

20

a second switching element connected to the first signal line and the fourth signal line to transmit a data voltage from the fourth signal line to the second subpixel electrode,

5 wherein the connection covers the third signal line or the fourth signal line.

15. The liquid crystal display of claim 14, wherein the second subpixel electrode further comprises a connection bridge enclosing the first subpixel electrode, and the connection bridge overlaps a portion of the first signal line, the third signal line, or the fourth signal line.

10

16. The liquid crystal display of claim 1, wherein the liquid crystal molecules are aligned with a pretilt along the length direction of the minute branches, and the liquid crystal layer further comprises polymers to pretilt the liquid crystal molecules, and the polymers are formed by irradiating ultraviolet rays to prepolymers of monomers.

15

17. The liquid crystal display of claim 1, further comprising

20

an alignment layer formed on the pixel electrode or the common electrode, wherein the alignment layer is light-aligned along the length direction of the minute branches.

* * * * *

专利名称(译)	液晶显示器		
公开(公告)号	US8610864	公开(公告)日	2013-12-17
申请号	US12/560976	申请日	2009-09-16
[标]申请(专利权)人(译)	三星电子株式会社		
申请(专利权)人(译)	SAMSUNG ELECTRONICS CO. , LTD.		
当前申请(专利权)人(译)	三星DISPLAY CO. , LTD.		
[标]发明人	LEE EUN GUK YANG BYUNG DUK KONG HYANG SHIK YU SE HWAN KWAK SANG KI HAN KYOUNG TAI KIM DONG YOON		
发明人	LEE, EUN-GUK YANG, BYUNG-DUK KONG, HYANG-SHIK YU, SE-HWAN KWAK, SANG-KI HAN, KYOUNG-TAI KIM, DONG-YOON		
IPC分类号	G02F1/1343 G02F1/1337		
CPC分类号	G02F1/133753 G02F1/134309 G02F1/13624 G02F1/1393 G02F2001/134345		
审查员(译)	WON , BUMSUK		
助理审查员(译)	常 , CHARLES		
优先权	1020090008417 2009-02-03 KR		
其他公开文献	US20100195034A1		
外部链接	Espacenet USPTO		

摘要(译)

根据本发明示范性实施例的液晶显示器包括：像素电极，包括第一子像素电极和第二子像素电极，第二子像素电极之间具有间隙；面向像素电极的公共电极；液晶层形成在像素电极和公共电极之间，并包括多个液晶分子，其中第一和第二子像素电极包括多个微小分支，第一和第二子像素电极包括多个子区域微小分支的不同长度方向，并且微小分支的宽度比相邻微小分支之间的间隔宽。

