



US008184244B2

(12) **United States Patent**  
**Ueda et al.**

(10) **Patent No.:** **US 8,184,244 B2**  
(45) **Date of Patent:** **May 22, 2012**

(54) **LIQUID CRYSTAL DISPLAY APPARATUS**

5,825,445	A *	10/1998	Okamoto et al.	349/118
6,219,122	B1 *	4/2001	Uchida et al.	349/117
6,795,139	B1 *	9/2004	Kameyama et al.	349/96
2002/0135725	A1 *	9/2002	Terashita et al.	349/129
2006/0072054	A1 *	4/2006	Ito	349/96

(75) Inventors: **Narifumi Ueda**, Ibaraki (JP); **Nao Murakami**, Ibaraki (JP); **Hiroyuki Yoshimi**, Ibaraki (JP)

**FOREIGN PATENT DOCUMENTS**

(73) Assignee: **Nitto Denko Corporation**, Ibarakishi-shi (JP)

JP	1996-295820	A	11/1996
JP	11-095208		4/1999
JP	2001 290149	A	10/2001
JP	2001 356332	A	12/2001
JP	2003-121642	A	4/2003
JP	2003 241181	A	8/2003
JP	2004-004755	A	1/2004
JP	2004-347699	A	12/2004

(\* ) Notice: Subject to any disclaimer, the term of this patent is extended or adjusted under 35 U.S.C. 154(b) by 648 days.

\* cited by examiner

(21) Appl. No.: **11/084,199**

(22) Filed: **Mar. 21, 2005**

*Primary Examiner* — Lucy Chien

(65) **Prior Publication Data**

(74) *Attorney, Agent, or Firm* — Westerman, Hattori, Daniels & Adrian, LLP

US 2006/0164580 A1 Jul. 27, 2006

(30) **Foreign Application Priority Data**

(57) **ABSTRACT**

Jan. 25, 2005 (JP) ..... 2005-016282  
Feb. 3, 2005 (JP) ..... 2005-027692

A liquid crystal display apparatus of the present invention includes: a liquid crystal cell including a pair of substrates provided with a color filter on one substrate, and a liquid crystal layer as a display medium provided between the substrates; and an optical compensation element including at least an optical compensation layer. The optical compensation element is arranged on the same side as the color filter with respect to the liquid crystal layer. The substrate provided with the color filter preferably has a haze value of 10% or less. Such a liquid crystal display apparatus allows excellent viewing angle compensation, exhibits exceptional contrast in an oblique direction, and can be reduced in thickness.

(51) **Int. Cl.**  
**G02F 1/1335** (2006.01)

(52) **U.S. Cl.** ..... **349/117**; 349/118

(58) **Field of Classification Search** ..... None  
See application file for complete search history.

(56) **References Cited**

**U.S. PATENT DOCUMENTS**

4,786,148	A *	11/1988	Sekimura et al.	349/106
5,213,852	A *	5/1993	Arakawa et al.	428/1.2

**11 Claims, 7 Drawing Sheets**

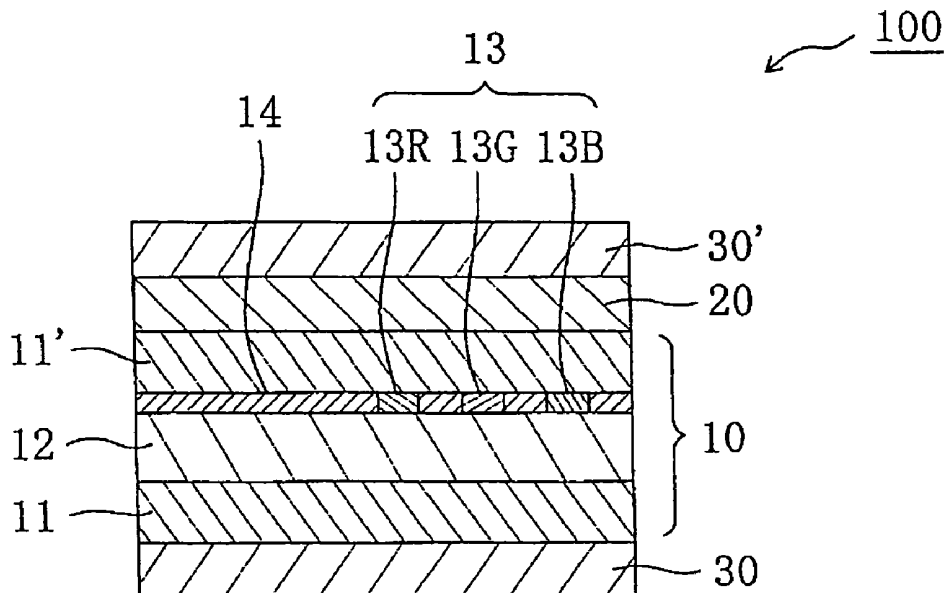

Fig. 1

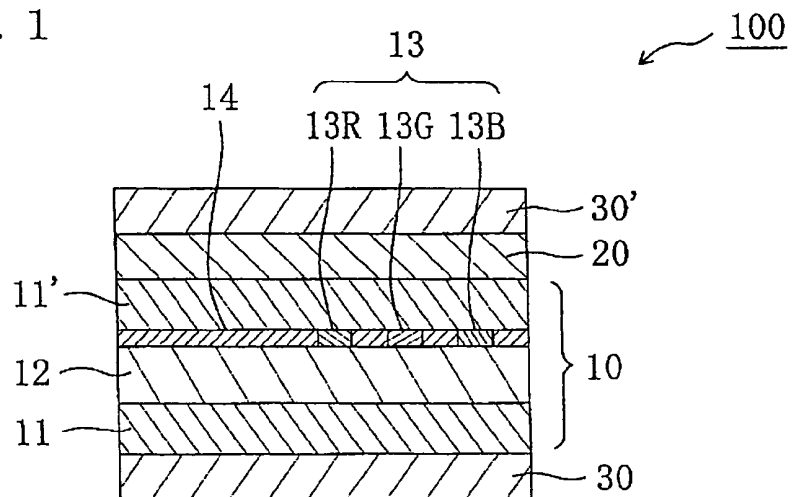

Fig. 2

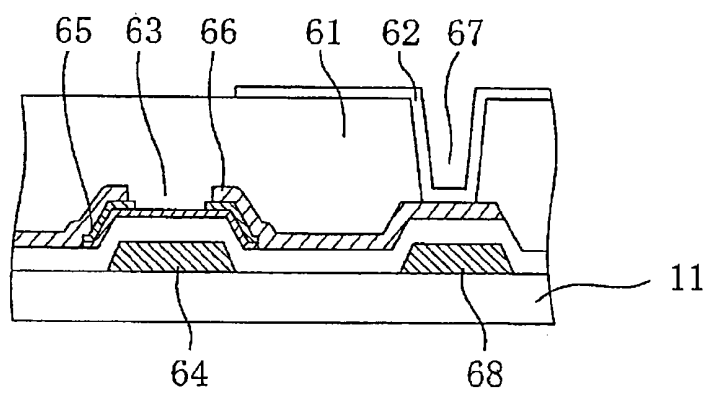

Fig. 3

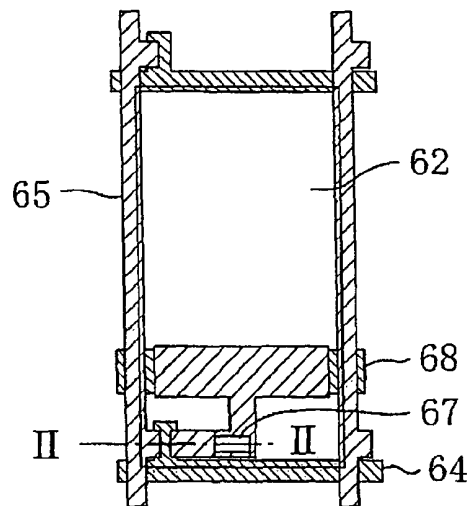

Fig. 4A

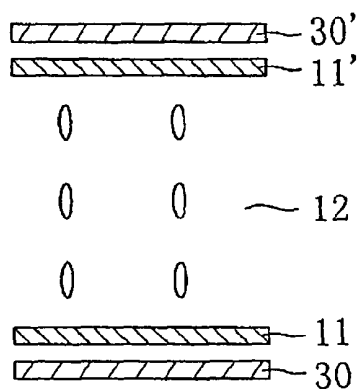

Fig. 4B

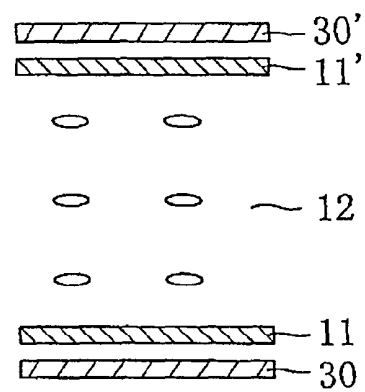

Fig. 5A

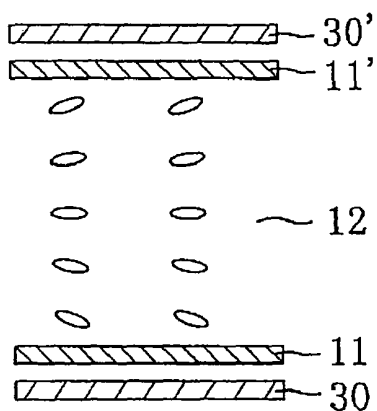

Fig. 5B

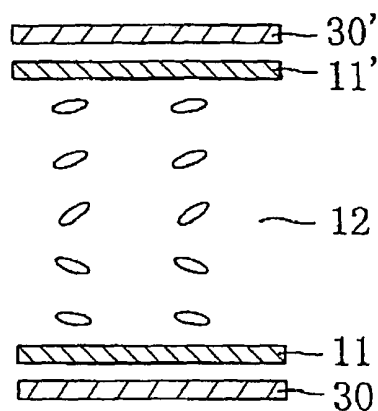

Fig. 5C

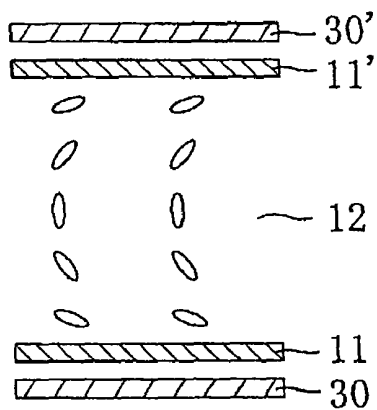

Fig. 5D

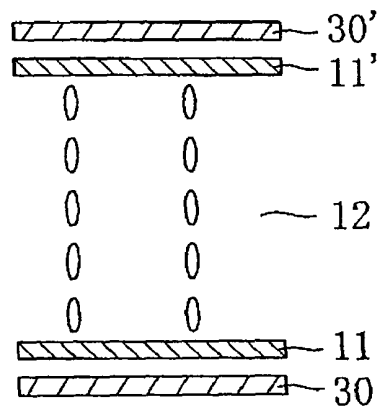

Fig. 6A

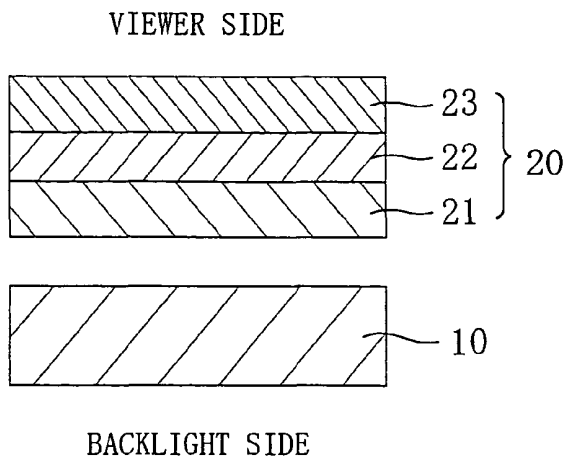

Fig. 6B

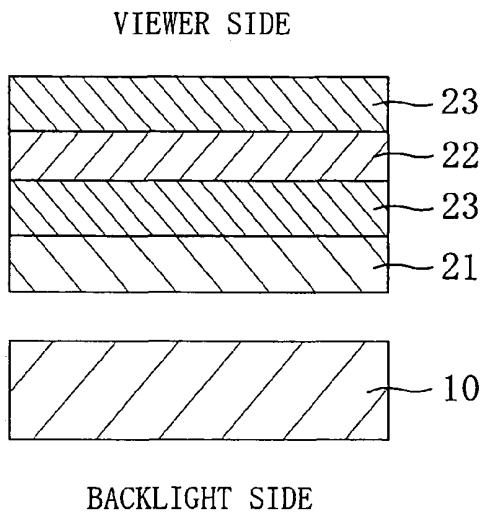

Fig. 6C

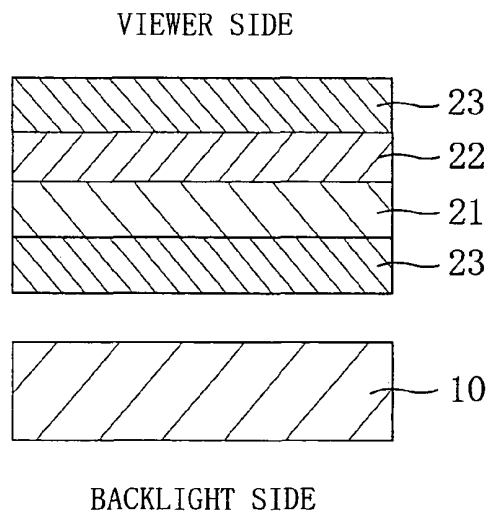

Fig. 7

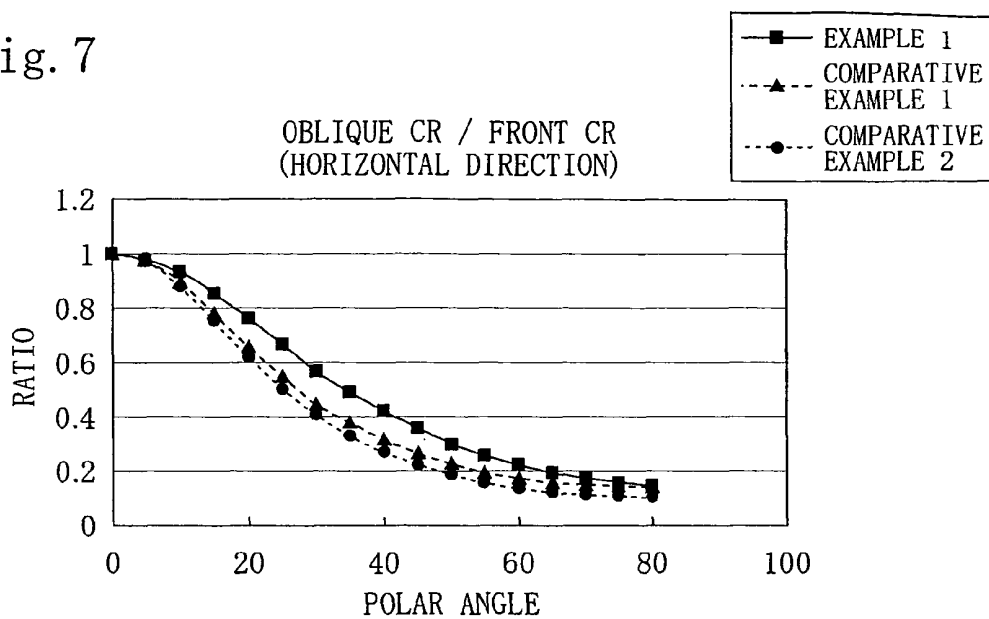

Fig. 8

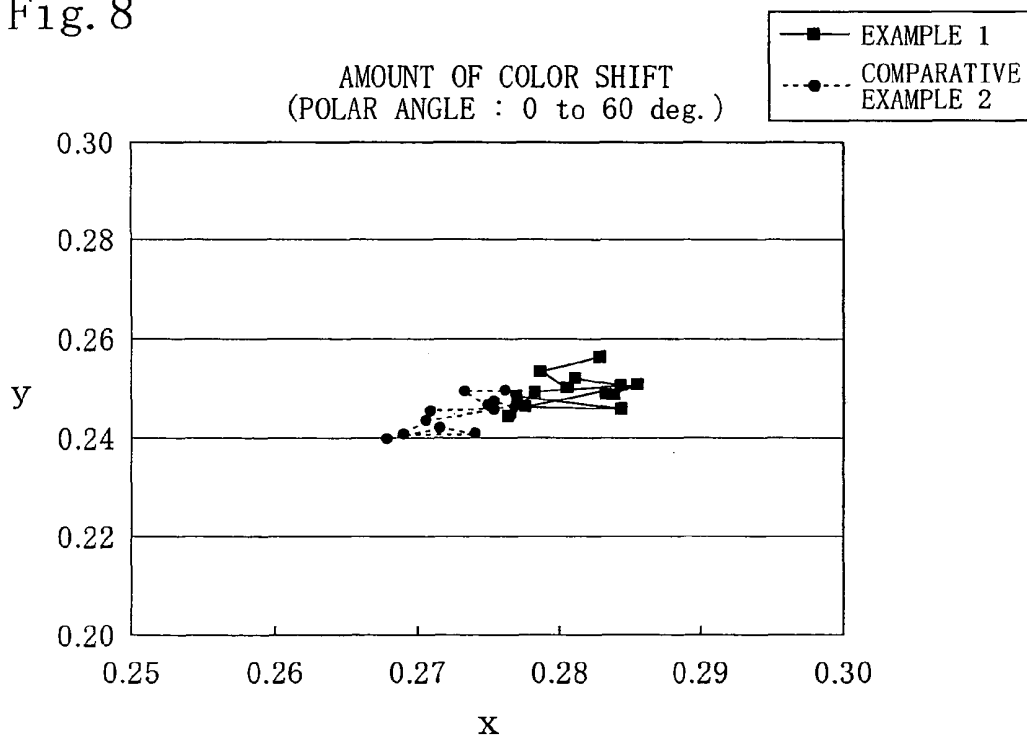

Fig. 9 A



Fig. 9 B

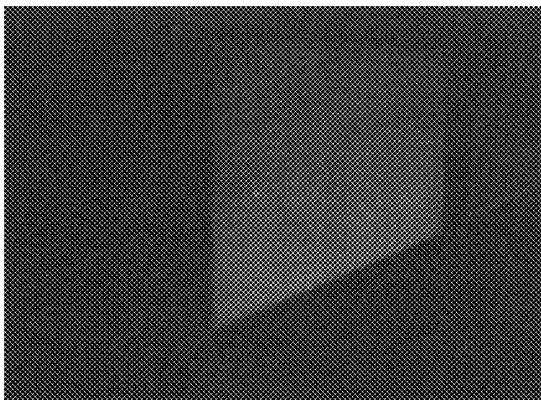

Fig. 10A

900

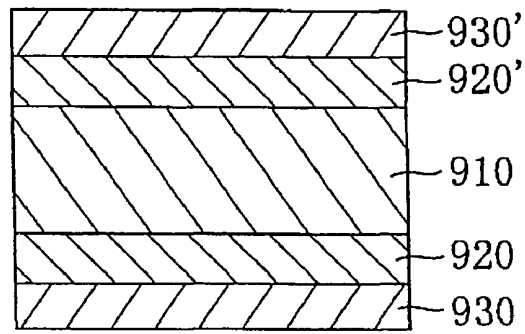
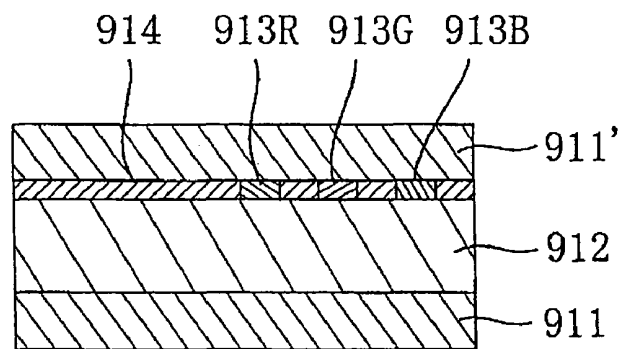

Fig. 10B

910



## LIQUID CRYSTAL DISPLAY APPARATUS

## BACKGROUND OF THE INVENTION

## 1. Field of the Invention

The present invention relates to a liquid crystal display apparatus. The present invention more specifically relates to a liquid crystal display apparatus which allows excellent viewing angle compensation, which exhibits exceptional contrast in an oblique direction, and which can be reduced in thickness.

## 2. Description of the Related Art

FIG. 10A shows a schematic sectional view of a conventional liquid crystal display apparatus, and FIG. 10B shows a schematic sectional view of a liquid crystal cell used for the liquid crystal display apparatus. A liquid crystal display apparatus 900 is provided with: a liquid crystal cell 910; retardation plates 920 and 920' arranged on outer sides of the liquid crystal cell 910; and polarizing plates 930 and 930' arranged on outer sides of the retardation plates 920 and 920', respectively. The polarizing plates 930 and 930' are generally arranged such that respective absorption axes thereof are perpendicular to each other. The liquid crystal cell 910 includes: a pair of substrates 911 and 911'; and a liquid crystal layer 912 as a display medium arranged between the substrates. One substrate 911 is provided with: a switching element (typically, TFT) for controlling electrooptic characteristics of liquid crystal; and a scanning line for providing a gate signal to the switching element and a signal line for providing a source signal thereto (the element and the lines not shown). The other substrate 911' is provided with: color layers 913R, 913G, and 913B constituting a color filter; and a light shielding layer (black matrix layer) 914. A space (cell gap) between the substrates 911 and 911' is controlled by a spacer (not shown).

The retardation plates are used for the purpose of optical compensation of the liquid crystal display apparatus. Various attempts have been made at optimization of optical characteristics of the retardation plates and/or at arrangement of the retardation plates in the liquid crystal display apparatus for attaining optimum optical compensation (such as improvement in viewing angle characteristics, improvement in color shift, and improvement in contrast). Conventionally, as shown in FIGS. 10A and 10B, one retardation plate is arranged between the liquid crystal cell 910 and the polarizing plate 930, and another retardation plate is arranged between the liquid crystal cell 910 and the polarizing plate 930' (see JP 11-095208 A, for example). In order to attain optimum optical compensation with such a structure, the retardation plates disclosed in JP 11-095208 A and arranged on both sides of the liquid crystal cell each have a thickness of 140  $\mu\text{m}$ . However, when conventional retardation plates are used in a liquid crystal display apparatus in a conventional arrangement, contrast in an oblique direction often degrades. Meanwhile, further improvement in screen uniformity and display quality is demanded with recent development of a high-definition and high-performance liquid crystal display apparatus. In consideration of such a demand, degradation of contrast in an oblique direction is a critical issue. Further, a demand for reduction in thickness of the liquid crystal display apparatus has increased with the development of a small, portable liquid crystal display apparatus. However, a liquid crystal display apparatus is hardly reduced in thickness if two thick retardation plates are arranged as in the conventional liquid crystal display apparatus.

As described above, a liquid crystal display apparatus capable of satisfying the demands for excellent display quality and reduction in thickness has been desired strongly.

## SUMMARY OF THE INVENTION

The present invention has been made in view of solving the above conventional problems, and an object of the present invention is therefore to provide a liquid crystal display apparatus which allows excellent viewing angle compensation, which exhibits exceptional contrast in an oblique direction, and which can be reduced in thickness.

A liquid crystal display apparatus according to an embodiment of the present invention includes: a liquid crystal cell including a pair of substrates provided with a color filter on one substrate, and a liquid crystal layer as a display medium arranged between the substrates; and an optical compensation element including at least an optical compensation layer, wherein the optical compensation element is arranged on the same side as the color filter with respect to the liquid crystal layer.

In one embodiment of the invention, the color filter and the optical compensation element are both arranged on a viewer side.

In another embodiment of the invention, the substrate provided with the color filter has a haze value of 10% or less.

In still another embodiment of the invention, the liquid crystal cell employs one of a VA mode and an OCB mode.

In still another embodiment of the invention, the optical compensation layer is formed from a non-liquid crystalline material.

In still another embodiment of the invention, the non-liquid crystalline material comprises at least one polymer selected from the group consisting of polyimide, polyamide, polyester, polyetherketone, polyamideimide, and polyesterimide.

In still another embodiment of the invention, the non-liquid crystalline material comprises polyimide.

In still another embodiment of the invention, the optical compensation layer has a refractive index profile of  $n_x > n_y > n_z$ .

In still another embodiment of the invention, the optical compensation layer has an in-plane retardation  $\Delta n d$  of 5 nm or more and 400 nm or less, and a thickness direction retardation  $R_{th}$  of 10 nm or more and 1,000 nm or less.

In still another embodiment of the invention, the optical compensation layer has an  $N_z$  coefficient of 2 to 20.

In still another embodiment of the invention, the optical compensation layer has a thickness of 1 to 20  $\mu\text{m}$ .

In still another embodiment of the invention, the optical compensation layer is a monolayer.

A liquid crystal display apparatus according to another embodiment of the present invention includes: a liquid crystal cell including a pair of substrates provided with a color filter on one substrate, and a liquid crystal layer as a display medium arranged between the substrates; an optical compensation element including at least an optical compensation layer and arranged on the same side as the color filter with respect to the liquid crystal layer; a pair of polarizing plates respectively arranged on an outer side of the optical compensation element and on a side of the liquid crystal cell on which the optical compensation element is not arranged; and a light source provided on an opposite side of the optical compensation element with respect to the liquid crystal cell.

In one embodiment of the invention, the color filter is structured to inhibit light scattering from the light source.

A liquid crystal display apparatus according to still another embodiment of the present invention includes: a liquid crystal

cell including a pair of substrates provided with a color filter on one substrate, and a liquid crystal layer as a display medium arranged between the substrates; an optical compensation element including an optical compensation layer and a polarizer and arranged on the same side as the color filter with respect to the liquid crystal layer; and a polarizing plate provided on a side of the liquid crystal cell on which the optical compensation element is not arranged.

In one embodiment of the invention, the optical compensation element has a slow axis of the optical compensation layer that is perpendicular to an absorption axis of the polarizer.

#### BRIEF DESCRIPTION OF THE DRAWINGS

In the accompanying drawings:

FIG. 1 is a schematic sectional view of a liquid crystal display apparatus according to a preferred embodiment of the present invention;

FIG. 2 is a schematic sectional view of an active matrix substrate used for the liquid crystal display apparatus of FIG. 1 taken along the line II-II of FIG. 3;

FIG. 3 is a schematic plan view of the active matrix substrate of FIG. 2;

FIGS. 4A and 4B are each a schematic sectional view illustrating an alignment state of liquid crystal molecules of a liquid crystal layer in a case where a liquid crystal display apparatus of the present invention employs a VA mode liquid crystal cell;

FIGS. 5A to 5D are each a schematic sectional view illustrating an alignment state of liquid crystal molecules of a liquid crystal layer in a case where a liquid crystal display apparatus of the present invention employs an OCB mode liquid crystal cell;

FIGS. 6A to 6C are each a schematic sectional view of an optical compensation element used for a liquid crystal display apparatus according to a preferred embodiment of the present invention;

FIG. 7 is a graph showing viewing angle dependence of contrast of a liquid crystal display apparatus of Example 1 of the present invention and liquid crystal display apparatuses of Comparative Examples 1 and 2;

FIG. 8 is a chromaticity diagram showing an amount of color shift of the liquid crystal display apparatus of Example 1 of the present invention and the liquid crystal display apparatus of Comparative Example 2;

FIGS. 9A and 9B are photographs of the liquid crystal display apparatus of Example 1 of the present invention and the liquid crystal display apparatus of Comparative Example 2 comparing chromaticity from an oblique direction; and

FIG. 10A is a schematic sectional view of a conventional liquid crystal display apparatus, and FIG. 10B is a schematic sectional view of a liquid crystal cell used for the liquid crystal display apparatus.

#### DESCRIPTION OF THE PREFERRED EMBODIMENTS

##### A. Liquid Crystal Display Apparatus

FIG. 1 is a schematic sectional view of a liquid crystal display apparatus according to a preferred embodiment of the present invention. FIG. 2 is a schematic sectional view of an active matrix substrate used for the liquid crystal display apparatus taken along the line II-II of FIG. 3. FIG. 3 is a schematic plan view of the active matrix substrate of FIG. 2.

A liquid crystal display apparatus 100 is provided with: a liquid crystal cell 10; an optical compensation element 20

provided on an outer side of the liquid crystal cell 10; a polarizing plate 30' provided on an outer side of the optical compensation element 20; and a polarizing plate 30 provided on a side of the liquid crystal cell 10 on which the optical compensation element 20 is not provided. The polarizing plates 30 and 30' each include a polarizer, and a transparent protective layer as required. The polarizing plates 30 and 30' are generally arranged such that absorption axes of the respective polarizers are perpendicular to each other. The liquid crystal cell 10 includes: a pair of glass substrates 11 and 11'; and a liquid crystal layer 12 as a display medium arranged between the substrates. One substrate (active matrix substrate) 11 is provided with: a switching element (typically, TFT) for controlling electrooptic characteristics of liquid crystal; and a scanning line for providing a gate signal to the switching element and a signal line for providing a source signal thereto (the element and the lines not shown). The other glass substrate (color filter substrate) 11' is provided with a color filter 13. The color filter 13 may be provided on the active matrix substrate 11. A space (cell gap) between the substrates 11 and 11' is controlled by a spacer (not shown). An alignment layer (not shown) formed of, for example, polyimide is provided on a side of each of the substrates 11 and 11' in contact with the liquid crystal layer 12.

In the liquid crystal display apparatus of the present invention, the optical compensation element 20 is arranged on the same side as the color filter 13 with respect to the liquid crystal layer 12. That is, with respect to the color filter 13, the optical compensation element 20 and the liquid crystal layer 12 are arranged on opposite sides. More specifically, the optical compensation element 20 is arranged on an outer side (viewer side in the figure) of the substrate (substrate 11' in the figure) provided with the color filter 13. A specific optical compensation element 20 is arranged on one side of the liquid crystal cell in a specific positional relationship with the color filter, to thereby obtain a liquid crystal display apparatus allowing exceptional viewing angle compensation and exhibiting exceptional contrast in an oblique direction. Such an effect is not theoretically clarified, is a finding obtained for the first time through actual production of a liquid crystal display apparatus, and is an unexpected and excellent effect. The substrate provided with the color filter preferably has a low haze value, specifically, a haze value of preferably 10% or less, particularly preferably 5% or less, most preferably 3% or less. A theoretical lower limit of the haze value is 0%, and a practical lower limit thereof is 0.5%. The above effect is significant with use of such a substrate provided with the color filter having a low haze value. In the present specification, the haze value of a substrate provided with a color filter refers to a haze value of a substrate including a light shielding layer (black matrix layer).

The active matrix substrate 11 is provided with an interlayer insulating film 61 over an entire surface on a side of the liquid crystal layer 12. The interlayer insulating film 61 is formed through spin coating of a photosensitive acrylic resin, for example. As shown in FIG. 2, a pixel electrode 62 is provided on the interlayer insulating film 61 in a matrix form, and a region provided with the pixel electrode 62 serves as a display portion for displaying an image. The pixel electrode 62 is composed of a transparent conductive material such as indium tin oxide (ITO). The pixel electrode 62 may be formed by: forming a thin film through, for example, sputtering; and patterning the thin film through photolithography and etching. Any suitable TFTs 63 provided in a matrix form, a scanning line 64 for supplying a gate signal to the TFT 63, and a signal line 65 for supplying a source signal (display signal) thereto are provided under the interlayer insulating film 61.

The scanning line **64** and the signal line **65** are provided to be perpendicular to each other. The TFT **63** generally includes: a semiconductor layer of amorphous silicon, polysilicon, or the like; and a metal layer of aluminum, molybdenum, chromium, copper, tantalum, or the like. The scanning line **64** and the signal line **65** are each formed of aluminum, molybdenum, copper, or the like. A part of the scanning line **64** constitutes a gate electrode of the TFT **63**, and a part of the signal line **65** constitutes a source electrode. One end of a connecting piece is electrically connected to a drain electrode **66** of the TFT **63**. The other end of the connecting piece is electrically connected to the pixel electrode **62** via a contact hole **67** penetrating through the interlayer insulating film **61**. A parasitic capacity wiring **68** extends below the contact hole **67**. Such a structure allows selective application of a voltage to the desired pixel electrode **62**.

The color filter substrate **11** is provided with the color filter **13** including color layers **13R**, **13G**, and **13B** for red (R), green (G), and blue (B) divided by a light shielding layer (black matrix layer) **14**. The color layers **13R**, **13G**, and **13B** are each formed using an acrylic resin, gelatin, or the like, and are provided at positions corresponding to the pixel electrode **62** in the display portion. The black matrix layer **14** may be formed of a metal, or may be formed of a resin material. A resin material is generally prepared by dispersing a pigment in an acrylic resin.

A drive mode of the liquid crystal cell **10** may employ any suitable drive modes as long as the effects of the present invention can be provided. Specific examples of the drive mode include a super twisted nematic (STN) mode, a twisted nematic (TN) mode, an in-plane switching (IPS) mode, a vertical aligned (VA) mode, an optically aligned birefringence (OCB) mode, a hybrid aligned nematic (HAN) mode, and an axially symmetric aligned microcell (ASM) mode. Of those, a VA mode and an OCB mode are preferred because viewing angle compensation and contrast in an oblique direction are significantly improved by combining a VA mode or OCB mode liquid crystal cell with the optical compensation element **20** of the present invention.

FIGS. **4A** and **4B** are each a schematic sectional view illustrating an alignment state of liquid crystal molecules in a VA mode. As shown in FIG. **4A**, liquid crystal molecules are aligned vertically to the substrates **11** and **11'** without application of a voltage. Such vertical alignment is realized by arranging nematic liquid crystal having negative dielectric anisotropy between the substrates each having a vertical alignment layer formed thereon (not shown). When light (specifically, linear polarized light which passed through the polarizing plate **30**) enters the liquid crystal layer **12** in such a state from a surface of one substrate **11**, the incident light advances along a longitudinal direction of the vertically aligned liquid crystal molecules. No birefringence occurs in the longitudinal direction of the liquid crystal molecules, and thus the incident light advances without changing a polarization direction and is absorbed by the polarizing plate **30'** having a polarizing axis perpendicular to the polarizing plate **30**. In this way, a dark state is displayed without application of a voltage (normally black mode) As shown in FIG. **4B**, longitudinal axes of the liquid crystal molecules is aligned parallel to the substrate surfaces when a voltage is applied between the electrodes. The liquid crystal molecules exhibit birefringence with linear polarized light entering the liquid crystal layer **12** in such a state, and a polarization state of the incident light changes in accordance with inclination of the liquid crystal molecules. Light passing through the liquid crystal layer during application of a predetermined maximum voltage is converted into linear polarized light having a polar-

ization direction rotated by  $90^\circ$ , for example. Thus, the light passes through the polarizing plate **30'**, and a bright state is displayed. Upon termination of voltage application, the display is returned to a dark state by an alignment restraining force. An applied voltage is changed to control inclination of the liquid crystal molecules, so as to change an intensity of light transmission from the polarizing plate **30'**. As a result, display of gradation can be realized.

FIGS. **5A** to **5D** are each a schematic sectional view illustrating an alignment state of liquid crystal molecules in an OCB mode. The OCB mode is a display mode in which the liquid crystal layer **12** is constituted by so-called bend alignment. As shown in FIG. **5C**, the bend alignment refers to an alignment state wherein: nematic liquid crystal molecules are aligned at a substantially parallel angle (alignment angle) in the vicinity of a substrate; the alignment angle of the liquid crystal molecules becomes vertical to a substrate plane toward the center of the liquid crystal layer; and the alignment angle changes successively and continuously to parallel with a facing substrate surface away from the center of the liquid crystal layer. Further, the bend alignment refers to an alignment state having no twist structure across the entire liquid crystal layer. Such bend alignment is formed as follows. As shown in FIG. **5A**, the liquid crystal molecules have a substantially homogeneous alignment in a state without application of an electric field or the like (initial state). However, the liquid crystal molecules each have a pretilt angle, and a pretilt angle in the vicinity of the substrate is different from a pretilt angle in the vicinity of the opposite substrate. A predetermined bias voltage (generally 1.5 V to 1.9 V) is applied (low voltage application) to the liquid crystal molecules, to thereby realize spray alignment as shown in FIG. **5B** and then into bend alignment as shown in FIG. **5C**. Then, a display voltage (generally 5 V to 7 V) is applied (high voltage application) to the state of bend alignment, and thus the liquid crystal molecules align/stand substantially vertical to the substrate surface as shown in FIG. **5D**. In a normally white display mode, light entering the liquid crystal layer in a state shown in FIG. **5D** during high voltage application through the polarizing plate **30** advances without changing a polarization direction and is absorbed by the polarizing plate **30'**, to thereby display a dark state. Upon reduction of a display voltage, the alignment is returned to bend alignment to display a bright state by an alignment restraining force of rubbing treatment. A display voltage is changed to control inclination of the liquid crystal molecules, so as to change an intensity of light transmission from the polarizing plate. As a result, display of gradation can be realized. The liquid crystal display apparatus provided with an OCB mode liquid crystal cell allows switching of phase transition from a spray alignment state to a bend alignment state at a very high speed, and has excellent dynamic image display characteristics compared to those of a liquid crystal display apparatus provided with a liquid crystal cell of another drive mode such as a TN mode or an IPS mode.

The liquid crystal display apparatus of the present invention may be suitably applied to a liquid crystal display TV, a cellular phone, and the like.

#### B. Optical Compensation Element

FIGS. **6A** to **6C** are each a schematic sectional view illustrating a preferred example of the optical compensation element **20** used in the present invention. The optical compensation element **20** includes: an optical compensation layer **21**; and a polarizer **22** and/or a transparent protective layer **23** as required. Hereinafter, each member will be described in more detail.

## B-1. Optical Compensation Layer

An in-plane retardation (front retardation)  $\Delta nd$  of the optical compensation layer **21** may be optimized in accordance with the display mode of the liquid crystal cell. The  $\Delta nd$  is preferably 5 nm or more, more preferably 10 nm or more, most preferably 15 nm or more, for example. A  $\Delta nd$  of less than 5 nm often degrades contrast in an oblique direction. Meanwhile, the  $\Delta nd$  is preferably 400 nm or less, more preferably 300 nm or less, furthermore preferably 200 nm or less, particularly preferably 150 nm or less, especially preferably 100 nm or less, most preferably 80 nm or less. A  $\Delta nd$  more than 400 nm often reduces a viewing angle. More specifically, the liquid crystal cell employing a VA mode has a  $\Delta nd$  of preferably 5 to 150 nm, more preferably 10 to 100 nm, most preferably 15 to 80 nm. The liquid crystal cell employing an OCB mode has a  $\Delta nd$  of preferably 5 to 400 nm, more preferably 10 to 300 nm, most preferably 15 to 200 nm. Note that, the  $\Delta nd$  can be determined from an equation:  $\Delta nd = (n_x - n_y) \times d$ . Here,  $n_x$  represents a refractive index of the optical compensation layer in a slow axis direction, and  $n_y$  represents a refractive index of the optical compensation layer in a fast axis direction.  $d$  (nm) represents a thickness of the optical compensation layer. The  $\Delta nd$  is generally measured using light of a wavelength of 590 nm. The slow axis refers to a direction which shows the maximum in-plane refractive index in the plane of the film, and the fast axis refers to a direction perpendicular to the slow axis in the same plane.

Further, a thickness direction retardation  $R_{th}$  of the optical compensation layer **21** may be optimized in accordance with the display mode of the liquid crystal cell as well. The  $R_{th}$  is preferably 10 nm or more, more preferably 20 nm or more, most preferably 50 nm or more, for example. An  $R_{th}$  of less than 10 nm of ten degrades contrast in an oblique direction. Meanwhile, the  $R_{th}$  is preferably 1,000 nm or less, more preferably 500 nm or less, furthermore preferably 400 nm or less, particularly preferably 300 nm or less, especially preferably 280 nm or less, most preferably 260 nm or less. An  $R_{th}$  exceeding 1,000 nm may excessively increase optical compensation, thereby resulting in degradation of contrast in an oblique direction. More specifically, the liquid crystal cell employing a VA mode has an  $R_{th}$  of preferably 10 to 300 nm, more preferably 20 to 280 nm, most preferably 50 to 260 nm. The liquid crystal cell employing an OCB mode has an  $R_{th}$  of preferably 10 to 1,000 nm, more preferably 20 to 500 nm, most preferably 50 to 400 nm. Note that, the  $R_{th}$  can be determined from an equation:  $R_{th} = (n_x - n_z) \times d$ . Here,  $n_z$  represents a refractive index of the film (optical compensation layer) in a thickness direction. The  $R_{th}$  is also generally measured using light of a wavelength of 590 nm.

An  $N_z$  coefficient ( $=R_{th}/\Delta nd$ ) of the optical compensation layer **21** may be optimized in accordance with the display mode of the liquid crystal cell. The  $N_z$  coefficient is preferably 2 to 20, more preferably 2 to 10, furthermore preferably 2 to 8, most preferably 2 to 6, for example. More specifically, the liquid crystal cell employing a VA mode has an  $N_z$  coefficient of preferably 2 to 10, more preferably 2 to 8, most preferably 2 to 6. The liquid crystal cell employing an OCB mode has an  $N_z$  coefficient of preferably 2 to 20, more preferably 2 to 10, most preferably 2 to 8. Further, the optical compensation layer **21** has a refractive index profile of  $n_x > n_y > n_z$ . The optical compensation layer having such optical characteristics (that is,  $\Delta nd$ ,  $R_{th}$ , refractive index profile, and  $N_z$  coefficient) is arranged on the same side as the color filter substrate having a low haze value with respect to the

liquid crystal layer, to thereby obtain a liquid crystal display apparatus allowing exceptional viewing angle compensation and exhibiting exceptional contrast in an oblique direction.

The optical compensation layer **21** may be a monolayer or a laminate of two or more layers. A material constituting each layer of the laminate as the optical compensation layer **21** and a thickness of each layer thereof may be arbitrarily set as long as the entire laminate has the above optical characteristics.

The optical compensation layer may have any suitable thickness as long as the effects of the present invention can be provided. The optical compensation layer generally has a thickness of 0.1 to 50  $\mu\text{m}$ , preferably 0.5 to 30  $\mu\text{m}$ , more preferably 1 to 20  $\mu\text{m}$ , to thereby contribute to reduction in thickness of the liquid crystal display apparatus and obtain an optical compensation layer allowing excellent viewing angle compensation performance and exhibiting uniform retardation. The present invention may realize excellent viewing angle compensation using an optical compensation layer (optical compensation element) having a considerably small thickness compared to that of a conventional retardation plate and using such an optical compensation layer (optical compensation element) alone.

## B-2. Material Constituting Optical Compensation Layer

Any suitable materials may be employed as a material constituting the optical compensation layer as long as the optical compensation layer has the above optical characteristics. An example of such a material includes a non-liquid crystalline material. The material is particularly preferably a non-liquid crystalline polymer. The non-liquid crystalline material differs from a liquid crystalline material and may form an optically uniaxial film with  $n_x > n_z$  or  $n_y > n_z$  as property of the non-liquid crystalline material, regardless of alignment of the substrate. As a result, the non-liquid crystalline material may employ not only an alignment-treated substrate, but also an untreated substrate in a step of forming the optical compensation layer. Further, a step of applying an alignment layer on a substrate surface, a step of laminating an alignment layer, or the like may be omitted even when an untreated substrate is employed.

A preferred example of the non-liquid crystalline material includes a polymer such as polyamide, polyimide, polyester, polyetherketone, polyamideimide, or polyesterimide since such a material has excellent thermal resistance, excellent chemical resistance, excellent transparency, and sufficient rigidity. One type of polymer may be used, or a mixture of two or more types thereof having different functional groups such as a mixture of polyaryletherketone and polyamide may be used. Of those, polyimide is particularly preferred in view of high transparency, high alignment ability, and high extension.

A molecular weight of the polymer is not particularly limited. However, the polymer has a weight average molecular weight ( $M_w$ ) of preferably within a range of 1,000 to 1,000,000, more preferably within a range of 2,000 to 500,000, for example.

Polyimide which has high in-plane alignment ability and which is soluble in an organic solvent is preferred as polyimide used in the present invention, for example. More specifically, a polymer disclosed in JP 2000-511296 A, containing a condensation polymerization product of 9,9-bis(aminoaryl)fluorene and aromatic tetracarboxylic dianhydride, and containing at least one repeating unit represented by the following formula (1) can be used.

9

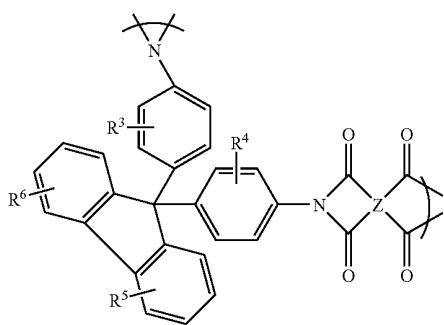

In the above formula (1),  $R^3$  to  $R^6$  independently represent at least one type of substituent selected from hydrogen, a halogen, a phenyl group, a phenyl group substituted with 1 to 4 halogen atoms or 1 to 4 alkyl groups each having 1 to 10 carbon atoms, and an alkyl group having 1 to 10 carbon atoms. Preferably,  $R^3$  to  $R^6$  independently represent at least one type of substituent selected from a halogen, a phenyl group, a phenyl group substituted with 1 to 4 halogen atoms or 1 to 4 alkyl groups each having 1 to 10 carbon atoms, and an alkyl group having 1 to 10 carbon atoms.

In the above formula (1), Z represents a tetravalent aromatic group having 6 to 20 carbon atoms, and preferably represents a pyromellitic group, a polycyclic aromatic group, a derivative of the polycyclic aromatic group, or a group represented by the following formula (2), for example.

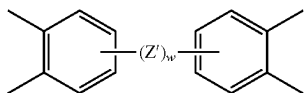

In the above formula (2), Z' represents a covalent bond, a  $C(R^7)_2$  group, a CO group, an O atom, an S atom, an  $SO_2$  group, a  $Si(C_2H_5)_2$  group, or an  $NR^8$  group. A plurality of Z's may be the same or different from each other. w represents an integer of 1 to 10.  $R^7$ 's independently represent hydrogen or a  $C(R^9)_3$  group.  $R^8$  represents hydrogen, an alkyl group having 1 to about 20 carbon atoms, or an aryl group having 6 to 20 carbon atoms. A plurality of  $R^8$ 's may be the same or different from each other.  $R^9$ 's independently represent hydrogen, fluorine, or chlorine.

An example of the polycyclic aromatic group includes a tetravalent group derived from naphthalene, fluorene, benzofluorene, or anthracene. An example of the substituted derivative of the polycyclic aromatic group includes the above polycyclic aromatic group substituted with at least a group selected from an alkyl group having 1 to 10 carbon atoms, a fluorinated derivative thereof, and a halogen such as F or Cl.

Other examples of the polyimide include: a homopolymer disclosed in JP 08-511812 A and containing a repeating unit represented by the following general formula (3) or (4); and polyimide disclosed therein and containing a repeating unit represented by the following general formula (5). Note that, polyimide represented by the following formula (5) is a preferred form of the homopolymer represented by the following formula (3).

10

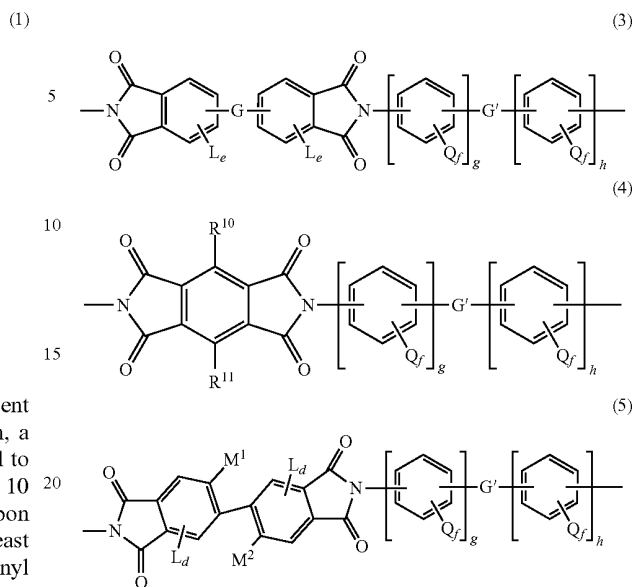

In the above general formulae (3) to (5), G and G' independently represent a covalent bond, a  $CH_2$  group, a  $C(CH_3)_2$  group, a  $C(CF_3)_2$  group, a  $C(CX_3)_2$  group (wherein, X represents a halogen), a CO group, an O atom, an S atom, an  $SO_2$  group, a Si  $(CH_2CH_3)_2$  group, or an  $N(CH_3)$  group, for example. G and G' may be the same or different from each other.

In the above formulae (3) and (5), L is a substituent, and d and e each represent the number of the substituents. L represents a halogen, an alkyl group having 1 to 3 carbon atoms, a halogenated alkyl group having 1 to 3 carbon atoms, a phenyl group, or a substituted phenyl group, for example. A plurality of Ls may be the same or different from each other. An example of the substituted phenyl group includes a substituted phenyl group having at least one type of substituent selected from a halogen, an alkyl group having 1 to 3 carbon atoms, and a halogenated alkyl group having 1 to 3 carbon atoms, for example. Examples of the halogen include fluorine, chlorine, bromine, and iodine. d represents an integer of 0 to 2, and e represents an integer of 0 to 3.

In the above formulae (3) to (5), Q is a substituent, and f represents the number of the substituents. Q represents an atom or a group selected from hydrogen, a halogen, an alkyl group, a substituted alkyl group, a nitro group, a cyano group, a thioalkyl group, an alkoxy group, an aryl group, a substituted aryl group, an alkylester group, and a substituted alkylester group, for example. A plurality of Qs may be the same or different from each other. Examples of the halogen include fluorine, chlorine, bromine, and iodine. An example of the substituted alkyl group includes a halogenated alkyl group. An example of the substituted aryl group includes a halogenated aryl group. f represents an integer of 0 to 4, and g represents an integer of 0 to 3. h represents an integer of 1 to 3. g and h are each preferably larger than 1.

In the above formula (4),  $R^{10}$  and  $R^{11}$  independently represent an atom or a group selected from hydrogen, a halogen, a phenyl group, a substituted phenyl group, an alkyl group, and a substituted alkyl group. Preferably,  $R^{10}$  and  $R^{11}$  independently represent a halogenated alkyl group.

In the above formula (5),  $M^1$  and  $M^2$  independently represent a halogen, an alkyl group having 1 to 3 carbon atoms, a

halogenated alkyl group having 1 to 3 carbon atoms, a phenyl group, or a substituted phenyl group, for example. Examples of the halogen include fluorine, chlorine, bromine, and iodine. An example of the substituted phenyl group includes a substituted phenyl group having at least one type of substituent selected from the group consisting of a halogen, an alkyl group having 1 to 3 carbon atoms, and a halogenated alkyl group having 1 to 3 carbon atoms.

A specific example of the polyimide represented by the above formula (3) includes a compound represented by the following formula (6).

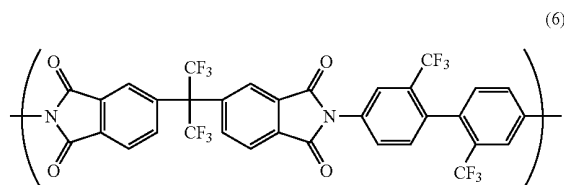

Another example of the polyimide includes a copolymer prepared through arbitrary copolymerization of acid dianhydride having a skeleton (repeating unit) other than that as described above and diamine.

An example of the acid dianhydride includes an aromatic tetracarboxylic dianhydride. Examples of the aromatic tetracarboxylic dianhydride include pyromellitic dianhydride, benzophenone tetracarboxylic dianhydride, naphthalene tetracarboxylic dianhydride, heterocyclic aromatic tetracarboxylic dianhydride, and 2,2'-substituted biphenyltetracarboxylic dianhydride.

Examples of the pyromellitic dianhydride include: pyromellitic dianhydride; 3,6-diphenyl pyromellitic dianhydride; 3,6-bis(trifluoromethyl)pyromellitic dianhydride; 3,6-dibromopyromellitic dianhydride; and 3,6-dichloropyromellitic dianhydride. Examples of the benzophenone tetracarboxylic dianhydride include: 3,3',4,4'-benzophenone tetracarboxylic dianhydride; 2,3,3',4'-benzophenone tetracarboxylic dianhydride; and 2,2',3,3'-benzophenone tetracarboxylic dianhydride. Examples of the naphthalene tetracarboxylic dianhydride include: 2,3,6,7-naphthalene tetracarboxylic dianhydride; 1,2,5,6-naphthalene tetracarboxylic dianhydride; and 2,6-dichloronaphthalene-1,4,5,8-tetracarboxylic dianhydride. Examples of the heterocyclic aromatic tetracarboxylic dianhydride include: thiophene-2,3,4,5-tetracarboxylic dianhydride; pyrazine-2,3,5,6-tetracarboxylic dianhydride; and pyridine-2,3,5,6-tetracarboxylic dianhydride. Examples of the 2,2'-substituted biphenyltetracarboxylic dianhydride include: 2,2'-dibromo-4,4',5,5'-biphenyltetracarboxylic dianhydride; 2,2'-dichloro-4,4',5,5'-biphenyltetracarboxylic dianhydride; and 2,2'-bis(trifluoromethyl)-4,4',5,5'-biphenyltetracarboxylic dianhydride.

Further examples of the aromatic tetracarboxylic dianhydride include: 3,3',4,4'-biphenyltetracarboxylic dianhydride; bis(2,3-dicarboxyphenyl)methane dianhydride; bis(2,5,6-trifluoro-3,4-dicarboxyphenyl)methane dianhydride; 2,2-bis(3,4-dicarboxyphenyl)-1,1,1,3,3,3-hexafluoropropane dianhydride; 4,4'-bis(3,4-dicarboxyphenyl)-2,2-diphenylpropane dianhydride; bis(3,4-dicarboxyphenyl)ether dianhydride; 4,4'-oxydiphthalic dianhydride; bis(3,4-dicarboxyphenyl)sulfonic dianhydride; 3,3',4,4'-diphenylsulfone tetracarboxylic dianhydride; 4,4'-[4,4'-isopropylidene-di(p-phenyleneoxy)]bis(phthalic dianhydride); N,N-(3,4-dicarboxyphenyl)-N-methylamine dianhydride; and bis(3,4-dicarboxyphenyl)diethylsilane dianhydride.

Of those, the aromatic tetracarboxylic dianhydride is preferably 2,2'-substituted biphenyltetracarboxylic dianhydride, more preferably 2,2'-bis(trihalomethyl)-4,4',5,5'-biphenyltetracarboxylic dianhydride, and furthermore preferably 2,2'-bis(trifluoromethyl)-4,4',5,5'-biphenyltetracarboxylic dianhydride.

An example of the diamine includes aromatic diamine. Specific examples of the aromatic diamine include benzenediamine, diaminobenzophenone, naphthalenediamine, heterocyclic aromatic diamine, and other aromatic diamines.

Examples of the benzenediamine include benzenediamines such as o-, m-, or p-phenylenediamine, 2,4-diaminotoluene, 1,4-diamino-2-methoxybenzene, 1,4-diamino-2-phenylbenzene, and 1,3-diamino-4-chlorobenzene.

Examples of the diaminobenzophenone include 2,2'-diaminobenzophenone and 3,3'-diaminobenzophenone. Examples of the naphthalenediamine include 1,8-diaminonaphthalene and 1,5-diaminonaphthalene. Examples of the heterocyclic aromatic diamine include 2,6-diaminopyridine, 2,4-diaminopyridine, and 2,4-diamino-S-triazine.

Further examples of the aromatic diamine include: 4,4'-diaminobiphenyl; 4,4'-diaminodiphenylmethane; 4,4'-(9-fluorenylidene)-dianiline; 2,2'-bis(trifluoromethyl)-4,4'-diaminobiphenyl; 3,3'-dichloro-4,4'-diaminodiphenylmethane; 2,2'-dichloro-4,4'-diaminobiphenyl; 2,2',5,5'-tetrachlorobenzidine; 2,2-bis(4-aminophenoxyphenyl)propane; 2,2-bis(4-aminophenyl)propane; 2,2-bis(4-aminophenyl)-1,1,1,3,3,3-hexafluoropropane; 4,4'-diaminodiphenyl ether; 3,4'-diaminodiphenyl ether; 1,3-bis(3-aminophenoxy)benzene; 1,3-bis(4-aminophenoxy)benzene; 1,4-bis(4-aminophenoxy)benzene; 4,4'-bis(4-aminophenoxy)biphenyl; 4,4'-bis(3-aminophenoxy)biphenyl; 2,2-bis[4-(4-aminophenoxy)phenyl]propane; 2,2-bis[4-(4-aminophenoxy)phenyl]-1,1,1,3,3,3-hexafluoropropane; 4,4'-diaminodiphenyl thioether; and 4,4'-diaminodiphenylsulfone.

An example of the polyetherketone includes polyaryletherketone disclosed in JP 2001-049110 A and represented by the following general formula (7).

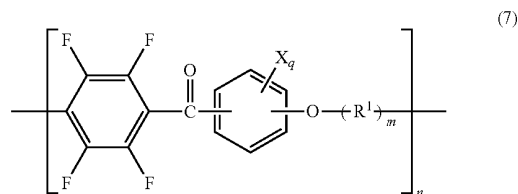

In the above formula (7), X represents a substituent, and q represents the number of the substituents. X represents a halogen atom, a lower alkyl group, a halogenated alkyl group, a lower alkoxy group, or a halogenated alkoxy group, for example. A plurality of Xs may be the same or different from each other.

Examples of the halogen atom include a fluorine atom, a bromine atom, a chlorine atom, and an iodine atom. Of those, a fluorine atom is preferred. The lower alkyl group is preferably an alkyl group having a straight chain or branched chain of 1 to 6 carbon atoms, more preferably an alkyl group having a straight chain or branched chain of 1 to 4 carbon atoms. More specifically, the lower alkyl group is preferably a methyl group, an ethyl group, a propyl group, an isopropyl group, a butyl group, an isobutyl group, a sec-butyl group, or a tert-butyl group, and particularly preferably a methyl group or an ethyl group. An example of the halogenated alkyl group

13

includes a halide of the above lower alkyl group such as a trifluoromethyl group. The lower alkoxy group is preferably an alkoxy group having a straight chain or branched chain of 1 to 6 carbon atoms, more preferably an alkoxy group having a straight chain or branched chain of 1 to 4 carbon atoms. More specifically, the lower alkoxy group is preferably a methoxy group, an ethoxy group, a propoxy group, an isopropoxy group, a butoxy group, an isobutoxy group, a sec-butoxy group, or a tert-butoxy group, and particularly preferably a methoxy group or an ethoxy group. An example of the halogenated alkoxy group includes a halide of the above lower alkoxy group such as a trifluoromethoxy group.

In the above formula (7), q is an integer of 0 to 4. In the above formula (7), preferably, q=0, and a carbonyl group and an oxygen atom of ether bonded to both ends of a benzene ring are located in para positions.

In the above formula (7), R<sup>1</sup> is a group represented by the following formula (8), and m is an integer of 0 or 1.

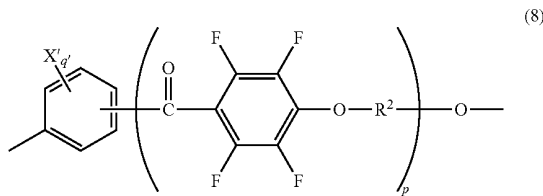

In the above formula (8), X' represents a substituent which is the same as X in the above formula (7), for example. In the above formula (8), a plurality of X's may be the same or different from each other. q' represents the number of the substituents X'. q' is an integer of 0 to 4, and q' is preferably 0. p is an integer of 0 or 1.

In the above formula (8), R<sup>2</sup> represents a divalent aromatic group. Examples of the divalent aromatic group include: an o-, m-, or p-phenylene group; and a divalent group derived from naphthalene, biphenyl, anthracene, o-, m-, or p-terphenyl, phenanthrene, dibenzofuran, biphenyl ether, or biphenyl sulfone. In the divalent aromatic group, hydrogen directly bonded to an aromatic group may be substituted with a halogen atom, a lower alkyl group, or a lower alkoxy group. Of those, R<sup>2</sup> is preferably an aromatic group selected from groups represented by the following formulae (9) to (15).

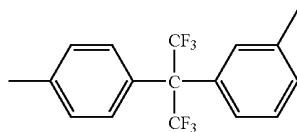
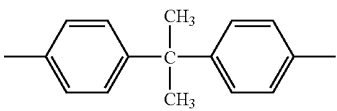
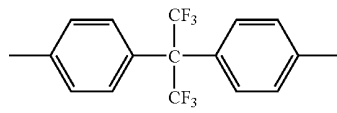

14

-continued

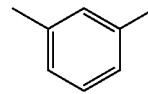
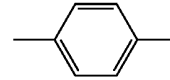
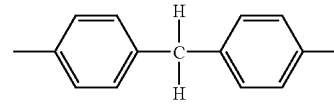
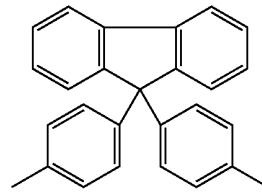

In the above formula (7), R<sup>2</sup> is preferably a group represented by the following formula (16). In the following formula (16), R<sup>2</sup> and p are defined as those in the above formula (8).

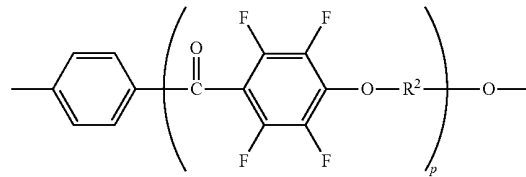

In the above formula (7), n represents a degree of polymerization. n falls within a range of 2 to 5,000, preferably within a range of 5 to 500, for example. Polymerization may involve polymerization of repeating units of the same structure or polymerization of repeating units of different structures. In the latter case, a polymerization form of the repeating units may be block polymerization or random polymerization.

Terminals of the polyaryletherketone represented by the above formula (7) are preferably a fluorine atom on a p-tetrafluorobenzoylene group side and a hydrogen atom on an oxyalkylene group side. Such polyaryletherketone can be represented by the following general formula (17), for example. In the following formula (17), n represents the same degree of polymerization as that in the above formula (7).

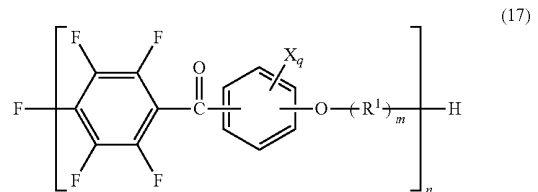

Specific examples of the polyaryletherketone represented by the above formula (7) include compounds represented by the following formulae (18) to (21). In each of the following formulae, n represents the same degree of polymerization as that in the above formula (7).

15

16

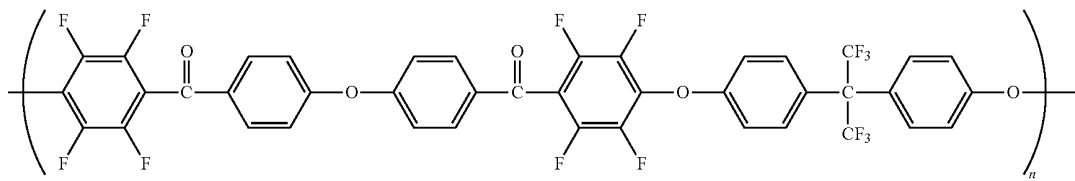

(18)

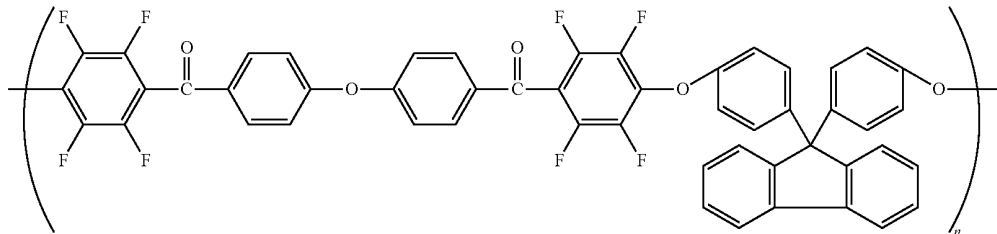

(19)

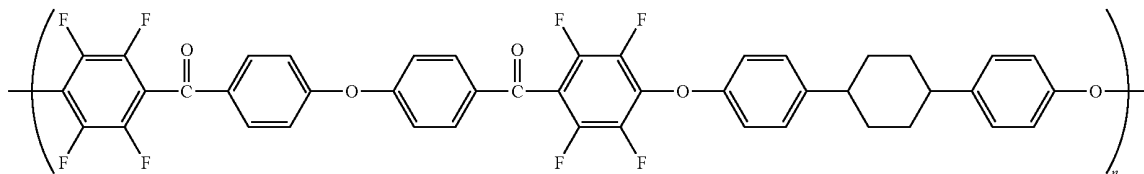

(20)

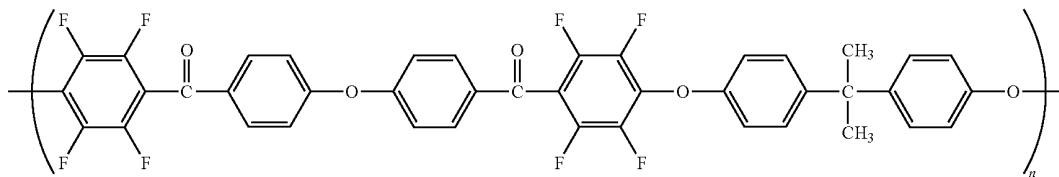

(21)

In addition, an example of polyamide or polyester includes polyamide or polyester disclosed in JP 10-508048 A. A repeating unit thereof can be represented by the following general formula (22), for example.

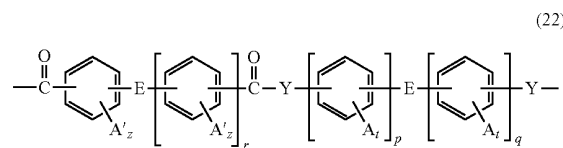

(22)

In the above formula (22), Y represents O or NH. E represents at least one selected from a covalent bond, an alkylene group having 2 carbon atoms, a halogenated alkylene group having 2 carbon atoms, a CH<sub>2</sub> group, a C(CX<sub>3</sub>)<sub>2</sub> group (wherein, X is a halogen or hydrogen), a CO group, an O atom, an S atom, an SO<sub>2</sub> group, an Si(R)<sub>2</sub> group, and an N(R) group, for example. A plurality of Es may be the same or different from each other. In E, R is at least one of an alkyl group having 1 to 3 carbon atoms and a halogenated alkyl group having 1 to 3 carbon atoms, and is located in a meta or para position with respect to a carbonyl functional group or a Y group.

In the above formula (22), A and A' each represent a substituent, and t and z represent the numbers of the respective

substituents. p represents an integer of 0 to 3, and q represents an integer of 1 to 3. r represents an integer of 0 to 3.

A is selected from hydrogen, a halogen, an alkyl group having 1 to 3 carbon atoms, a halogenated alkyl group having 1 to 3 carbon atoms, an alkoxy group represented by OR (wherein, R is defined as above), an aryl group, a substituted aryl group prepared through halogenation or the like, an alkoxy-carbonyl group having 1 to 9 carbon atoms, an alkyl-carbonyloxy group having 1 to 9 carbon atoms, an aryloxy-carbonyl group having 1 to 12 carbon atoms, an arylcarbonyloxy group having 1 to 12 carbon atoms and its substituted derivatives, an arylcarbonyl group having 1 to 12 carbon atoms, and arylcarbonylamino group having 1 to 12 carbon atoms and its substituted derivatives, for example. A plurality of As may be the same or different from each other. A' is selected from a halogen, an alkyl group having 1 to 3 carbon atoms, a halogenated alkyl group having 1 to 3 carbon atoms, a phenyl group, and a substituted phenyl group, for example. A plurality of A's may be the same or different from each other. Examples of the substituent on a phenyl ring of the substituted phenyl group include a halogen, an alkyl group having 1 to 3 carbon atoms, a halogenated alkyl group having 1 to 3 carbon atoms, a halogenated alkyl group having 1 to 3 carbon atoms, and the combination thereof. t represents an integer of 0 to 4, and z represents an integer of 0 to 3.

The repeating unit of the polyamide or polyester represented by the above formula (22) is preferably a repeating unit represented by the following general formula (23).

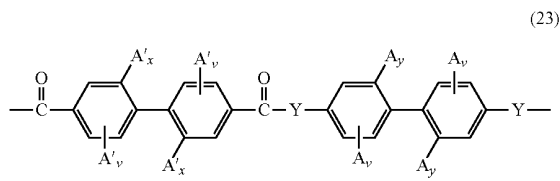

In the above formula (23), A, A', and Y are defined as those in the above formula (22). v represents an integer of 0 to 3, preferably an integer of 0 to 2. x and y are each 0 or 1, but are not both 0.

### B-3. Polarizer

As described above, the optical compensation element 20 further includes the polarizer 22 as required. As shown in FIGS. 6A to 6C, the polarizer 22 is provided such that the optical compensation layer 21 is arranged on a side of the liquid crystal cell 10. In the case where the optical compensation element includes a polarizer, the polarizing plate 30 may be omitted in the liquid crystal display apparatus, thereby contributing to reduction in thickness of the liquid crystal display apparatus. The optical compensation element including a polarizer may be provided as a member comparable to the so-called polarizing plate attached with a retardation plate.

Any suitable polarizers may be employed as the polarizer depending on the purpose. Examples of the polarizer include: a film prepared by adsorbing a dichromatic substance such as iodine or a dichromatic dye on a hydrophilic polymer film such as a polyvinyl alcohol-based film, a partially formalized polyvinyl alcohol-based film, or an ethylene/vinyl acetate copolymer-based partially saponified film and uniaxially stretching the film; and a polyene-based orientated film such as a dehydrated product of a polyvinyl alcohol-based film or a dechlorinated product of a polyvinyl chloride-based film. Of those, a polarizer prepared by adsorbing a dichromatic substance such as iodine on a polyvinyl alcohol-based film and uniaxially stretching the film is particularly preferred in view of high polarized dichromaticity. A thickness of the polarizer is not particularly limited, but is generally about 5 to 80  $\mu\text{m}$ .

The polarizer prepared by adsorbing iodine on a polyvinyl alcohol-based film and uniaxially stretching the film may be produced by, for example: immersing a polyvinyl alcohol-based film in an aqueous solution of iodine for coloring; and stretching the film to a 3 to 7 times length of the original length. The aqueous solution may contain boric acid, zinc sulfate, zinc chloride, or the like as required, or the polyvinyl alcohol-based film may be immersed in an aqueous solution of potassium iodide or the like. Further, the polyvinyl alcohol-based film may be immersed and washed in water before coloring as required. Washing the polyvinyl alcohol-based film with water not only allows removal of contamination on a film surface or washing away of an antiblocking agent, but also prevents nonuniformity such as uneven coloring or the like by swelling the polyvinyl alcohol-based film. The stretching of the film may be carried out after coloring of the film with iodine, carried out during coloring of the film, or carried out followed by coloring of the film with iodine. The stretching may be carried out in an aqueous solution of boric acid or potassium iodide, or in a water bath.

### B-4. Transparent Protective Layer

As described above, the optical compensation element 20 further includes the transparent protective layer 23 as required. As shown in FIGS. 6A to 6C, the transparent pro-

ductive layer 23 is arranged on an outer side (that is, as an outermost layer) of the polarizer 22. The transparent protective layer is provided, to thereby prevent degradation of the polarizer. As required, another transparent protective layer may be arranged between the optical compensation layer 21 and the polarizer 22 (see FIG. 6B), and/or between the optical compensation layer 21 and the liquid crystal cell 10 (see FIG. 6C).

Any suitable protective layers may be employed as the transparent protective layer depending on the purpose. The transparent protective layer is composed of a plastic film having excellent transparency, mechanical strength, thermal stability, water shielding property, isotropy, and the like, for example. Specific examples of a resin constituting the plastic film include an acetate resin such as triacetylcellulose (TAC), a polyester resin, a polyether sulfone resin, a polysulfone resin, a polycarbonate resin, a polyamide resin, a polyimide resin, a polyolefin resin, an acrylic resin, a polynorborene resin, a cellulose resin, a polyarylate resin, a polystyrene resin, a polyvinyl alcohol resin, and a mixture thereof. A further example thereof includes an acrylic-based, urethane-based, acrylic urethane-based, epoxy-based, or silicone-based thermosetting resin or UV-curing resin. Of those, a TAC film subjected to surface saponization treatment with alkali or the like is preferred in view of polarization characteristics and durability.

Further, a polymer film formed from a resin composition described in JP 2001-343529 A (WO 01/37007) may be used as a transparent protective layer, for example. More specifically, the film is formed from a mixture of a thermoplastic resin having a substituted imide group or unsubstituted imide group on a side chain, and a thermoplastic resin having a substituted phenyl group or unsubstituted phenyl group and a cyano group on a side chain. A specific example thereof includes a resin composition containing an alternate copolymer of isobutene and N-methylene maleimide, and an acrylonitrile/styrene copolymer. An extruded product of such a resin composition may be used, for example.

The transparent protective layer is by definition transparent and preferably has no color. More specifically, the transparent protective layer has a thickness direction retardation  $R_{th}$  of preferably  $-90$  nm to  $+75$  nm, more preferably  $-80$  nm to  $+60$  nm, most preferably  $-70$  nm to  $+45$  nm. A thickness direction retardation  $R_{th}$  of the transparent protective layer falling within the above range may eliminate optical coloring of the polarizer attributed to the protective layer.

A thickness of the protective layer may be arbitrarily set depending on the purpose. A thickness of the protective layer is generally 500  $\mu\text{m}$  or less, preferably 5 to 300  $\mu\text{m}$ , more preferably 5 to 150  $\mu\text{m}$ .

### B-5. Method of Producing Optical Compensation Element (Method of Forming Optical Compensation Layer)

Next, a method of producing the optical compensation element (method of forming the optical compensation layer) will be described. Any suitable methods may be employed as the method of producing the optical compensation element as long as an optical compensation element having the above optical characteristics can be obtained. The production method generally includes the steps of: applying a solution of the non-liquid crystalline polymer on a substrate film; and forming a layer of the non-liquid crystalline polymer by removing a solvent in the solution. When the optical compensation element is constituted by the optical compensation layer (optical compensation film) alone, the formed optical compensation layer is peeled off from the substrate film, to thereby obtain an optical compensation element. When the optical compensation element includes the polarizer and the

optical compensation layer, the production method further includes a step of attaching the polarizer onto a surface of the substrate film on which an optical compensation layer is not formed.

Any suitable films may be employed as the substrate film. A typical example of the substrate film includes a plastic film used for the protective layer of the polarizing plate described in the above section B-4.

The solvent of the application solution is not particularly limited. Examples of the solvent include: halogenated hydrocarbons such as chloroform, dichloromethane, carbon tetrachloride, dichloroethane, tetrachloroethane, trichloroethylene, tetrachloroethylene, chlorobenzene, and orthodichlorobenzene; phenols such as phenol and parachlorophenol; aromatic hydrocarbons such as benzene, toluene, xylene, methoxybenzene, and 1,2-dimethoxybenzene; ketone-based solvents such as acetone, methyl ethyl ketone, methyl isobutyl ketone, cyclohexanone, cyclopentanone, 2-pyrrolidone, and N-methyl-2-pyrrolidone; ester-based solvents such as ethyl acetate and butyl acetate; alcohol-based solvents such as t-butyl alcohol, glycerin, ethylene glycol, triethylene glycol, ethylene glycol monomethyl ether, diethylene glycol dimethyl ether, propylene glycol, dipropylene glycol, and 2-methyl-2,4-pentanediol; amide-based solvents such as dimethylformamide and dimethylacetamide; nitrile-based solvents such as acetonitrile and butyronitrile; ether-based solvents such as diethyl ether, dibutyl ether, and tetrahydrofuran; and carbon disulfide, ethyl cellosolve, and butyl cellosolve. Of those, methyl isobutyl ketone is preferred because it has high solubility to non-liquid crystalline materials and does not corrode the substrate. The solvent may be used alone or in combination of two or more types thereof.

Any suitable concentrations of the non-liquid crystalline polymer in the application liquid may be employed as long as the above optical compensation layer can be obtained and the solution can be applied on the film. For example, the solution contains preferably 5 to 50 parts by weight, more preferably 10 to 40 parts by weight of the non-liquid crystalline polymer with respect to 100 parts by weight of the solvent. The solution having a concentration within the above range has a viscosity that facilitates application thereof.

The application solution may further contain various additives such as stabilizers, plasticizers, and metals as required.

The application solution may further contain other resin as required. Examples of the other resin include various general-purpose resins, engineering plastics, thermoplastic resins, and thermosetting resins. The use of such resins allows formation of an optical compensation layer having appropriate mechanical strength or durability depending on the purpose.

Examples of the general-purpose resins include polyethylene (PE), polypropylene (PP), polystyrene (PS), poly(methyl methacrylate) (PMMA), an ABS resin, and an AS resin. Examples of the engineering plastics include polyacetate (POM), polycarbonate (PC), polyamide (PA: nylon), polyethylene terephthalate (PET), and polybutylene terephthalate (PBT). Examples of the thermoplastic resins include polyphenylene sulfide (PPS), polyethersulfone (PES), polyketone (PK), polyimide (PI), polycyclohexanedimethanol terephthalate (PCT), polyarylate (PAR), and a liquid crystal polymer (LCP). Examples of the thermosetting resins include an epoxy resin and a phenol novolac resin.

The type and amount of the other resin added to the application solution may be set arbitrarily depending on the purpose. The resin is added in a ratio of preferably 0 to 50 mass %, more preferably 0 to 30 mass % with respect to the non-liquid crystalline polymer, for example.

Examples of a method of applying the solution include spin coating, roll coating, flow coating, printing, dip coating, flow casting, bar coating, and gravure coating. For application, lamination of a polymer layer may also be used.

After the application, the solvent in the solution is removed through evaporation by natural drying, air drying, or drying under heating (at 60 to 250° C., for example), to thereby form an optical compensation layer in a form of film.

In the production method, treatment for imparting optically biaxial characteristics ( $n_x > n_y > n_z$ ) is preferably carried out. Such treatment can assuredly provide an in-plane difference in refractive index ( $n_x > n_y$ ), to thereby obtain an optical compensation layer having optically biaxial characteristics ( $n_x > n_y > n_z$ ). That is, an optical compensation layer having the optical characteristics described in the above section B-1 can be obtained. In other words, an optical compensation layer having optically uniaxial characteristics ( $n_x = n_y > n_z$ ) is obtained without such treatment. Examples of a method of imparting an in-plane difference in refractive index include the following two methods. A first method involves: applying the solution on a transparent polymer film subjected to stretching treatment; and drying the film. According to the first method, optically biaxial characteristics may be attained through shrinkage of the transparent polymer film. A second method involves: applying the solution on an unstretched transparent polymer film; drying the film; and stretching the film under heating. According to the second method, optically biaxial characteristics may be attained through stretching of the transparent polymer film. An example of the polymer film used for the methods includes the plastic film used for the transparent protective layer (section B-4).

As described above, the present invention can provide a liquid crystal display apparatus allowing exceptional viewing angle compensation and exhibiting exceptional contrast in an oblique direction by arranging a specific optical compensation element on one side of a liquid crystal cell, which is the same side as a color filter with respect to a liquid crystal layer. Such an effect is particularly remarkable when a haze value of a substrate provided with a color filter is small (generally 10% or less). On the other hand, when a haze value of the substrate provided with a color filter is large (15% or more, for example), the optical device may be arranged on the opposite side of the color filter with respect to the liquid crystal layer, to thereby obtain a liquid crystal display apparatus allowing excellent viewing angle compensation and exhibiting exceptional contrast in an oblique direction. Such an effect is not theoretically clarified, is a finding obtained for the first time through actual production of the liquid crystal display apparatus, and is an unexpected and excellent effect. A small haze value of the substrate provided with a color filter presumably inhibits light scattering when light of backlight (that is, polarized light) through a polarizing plate passes through the color filter. As a result, degradation of contrast not only in a frontal direction but also in an oblique direction is presumably suppressed, and coloring of display is presumably prevented. Further, the optical compensation layer of the optical compensation element used in the present invention has a considerably small thickness compared to that of a conventional retardation plate. Moreover, unlike a conventional liquid crystal display apparatus employing two retardation plates, the present invention uses only one such optical element to realize exceptional viewing angle compensation. Thus, the present invention may greatly contribute to reduction in thickness of the liquid crystal display apparatus.

Hereinafter, the present invention will be described in more detail by way of examples, but the present invention is not

limited to the examples. Methods of measuring characteristics in the examples are as described below.

(1) Measurement of Retardation

Refractive indices  $n_x$ ,  $n_y$ , and  $n_z$  of a sample film were measured using an automatic birefringence analyzer (Automatic birefringence analyzer KOBRA-21ADH, manufactured by Oji Scientific Instruments), and an in-plane retardation  $\Delta n_d$ , and a thickness direction retardation  $R_{th}$  were calculated. A measurement temperature was 23° C. and a measurement wavelength was 590 nm.

(2) Measurement of Contrast Ratio

A white image and a black image were displayed on the liquid crystal display apparatus produced, and a contrast ratio was measured using "EZ Contrast 160D" (trade name, manufactured by ELDIM SA)

(3) Measurement of Color Shift

A color tone of the liquid crystal display apparatus was measured while a polar angle was changed from 0° to 60° in a direction of an azimuth angle of 45° using "EZ Contrast 160D" (trade name, manufactured by ELDIM SA). The results were plotted on an XY chromaticity diagram.

(4) Measurement of Haze

A haze value was measured at room temperature using "Hazemeter HM-150" (manufactured by Murakami Color Research Laboratory).

PREPARATION EXAMPLE 1

Formation of Optical Compensation Layer

Polyimide represented by the following formula (6), synthesized from 2,2-bis(3,4-dicarboxyphenyl)hexafluoropropane dianhydride (6FDA) and 2,2'-bis(trifluoromethyl)-4,4'-diaminobiphenyl (TFMB), and having a weight average molecular weight (Mw) of 70,000 was dissolved in methyl isobutyl ketone, to thereby prepare a 15 wt % polyimide solution. Preparation of polyimide or the like was carried out by referring to a method described in a document (F. Li et al., Polymer 40 (1999) 4571-4583). Meanwhile, a triacetylcellulose (TAC) film having a thickness of 80  $\mu$ m was stretched in a width direction 1.3 times at 175° C. through fixed end stretching, to thereby produce a stretched TAC film having a thickness of 75  $\mu$ m as a substrate film. The polyimide solution was applied onto the substrate film to be dried at 100° C. for 10 minutes. As a result, an optical film A having an optical compensation layer on the substrate film was obtained. The optical compensation layer had a thickness of 6  $\mu$ m and a  $\Delta n(=n_x-n_z)$  of about 0.04. The optical compensation layer had a thickness direction retardation of 245 nm and an in-plane retardation of 55 nm. The optical compensation layer had optical characteristics of  $n_x > n_y > n_z$ . The substrate film (stretched TAC film) had a  $\Delta n$  of about 0.0006.

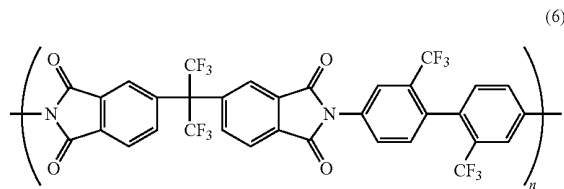

PREPARATION EXAMPLE 2

Production of Optical Compensation Element

A polyvinyl alcohol film was colored in an aqueous solution containing iodine and then uniaxially stretched 6 times

between rolls of different speed ratios in an aqueous solution containing boric acid, to thereby obtain a polarizer. The obtained polarizer was laminated on a surface of the substrate film of the optical film A on which the optical compensation layer is not formed. The polarizer was laminated such that a slow axis of the optical compensation layer and an absorption axis of the polarizer were substantially perpendicular to each other. Then, a commercially available TAC film (trade name "UZ-TAC", available from Fuji Photo Film Co., Ltd.) having a thickness of 40  $\mu$ m as a protective layer was laminated on a surface of the polarizer on which the optical film A is not laminated, to thereby obtain an optical compensation element B.

EXAMPLE 1

A liquid crystal cell was removed from a 32-inch liquid crystal monitor LTA260W2-L06 (installed with Patterned-VA liquid crystal cell, manufactured by SAMSUNG). The above optical compensation element B was attached to a viewer side of the liquid crystal cell (that is, the same side as the color filter with respect to the liquid crystal layer) through an acrylic adhesive (thickness of 20  $\mu$ m) such that the polarizer (actually, TAC protective layer thereof) was arranged on the outer side (viewer side). A polarizing plate (trade name "HEG1425DU", available from Nitto Denko Corporation) having a structure of TAC protective layer/polarizer/TAC protective layer was attached to a backlight side of the liquid crystal cell through an acrylic adhesive (thickness of 20  $\mu$ m). A haze value of the substrate provided with the color filter used for the liquid crystal panel was 2.8%. A liquid crystal display apparatus was produced using the liquid crystal panel, and contrast in a frontal direction and contrast in an oblique direction with varying polar angle from 0 to 80° of the liquid crystal display apparatus were measured. FIG. 7 shows a relationship between the polar angle and the contrast ratio (contrast in oblique direction/contrast in frontal direction) of the liquid crystal display apparatus of Example 1 along with the results of Comparative Examples 1 and 2 described below. FIG. 8 shows the results of the color shift measurement of the liquid crystal display apparatus of Example 1 along with the result of Comparative Example 2 described below. In addition, FIG. 9A shows a photograph of the liquid crystal display apparatus of Example 1 taken from an oblique direction.

COMPARATIVE EXAMPLE 1

A liquid crystal display apparatus was produced in the same manner as in Example 1 except that a 30-inch liquid crystal monitor (manufactured by Sharp Corporation) was used. A haze value of a substrate provided with a color filter used for the liquid crystal monitor was 16.2%. Contrast of the obtained liquid crystal display apparatus in a frontal direction and contrast thereof in an oblique direction were measured in the same manner as in Example 1. FIG. 7 shows the results.

COMPARATIVE EXAMPLE 2

A liquid crystal display apparatus was produced in the same manner as in Example 1 except that the optical compensation element B was arranged on a backlight side of the liquid crystal cell. The obtained liquid crystal display apparatus was evaluated in the same manner as in Example 1. FIGS. 7 and 8 show the results. FIG. 9B shows a photograph of the liquid crystal display apparatus of Comparative Example 2 taken from an oblique direction.

FIG. 7 reveals that the liquid crystal display apparatus of the present invention had contrast degradation in an oblique direction to a smaller extent than those of the liquid crystal display apparatuses of Comparative Examples. The liquid crystal display apparatus of the present invention had a larger contrast ratio (contrast in oblique direction/contrast in frontal direction) by about 50% at a polar angle of about 45° than those of Comparative Examples. Further, FIG. 8 reveals that the liquid crystal display apparatus of the present invention had smaller color shift than those of the liquid crystal display apparatuses of Comparative Examples, and had an almost neutral color tone. Actually, FIGS. 9A and 9B reveal that the liquid crystal display apparatus of the present invention has considerably small blueness as compared to that of the liquid crystal display apparatus of Comparative Example 2.

As is clear from the thickness of the optical compensation layer of Preparation Example 1, the optical compensation element used in the present invention has considerably small thickness compared to that of a conventional retardation plate (thickness of 140 μm, for example). Further, the liquid crystal display apparatus of Example 1 reveals that the use of one such element can realize exceptional viewing angle compensation, to thereby greatly contribute to reduction in thickness of the liquid crystal display apparatus.

Many other modifications will be apparent to and be readily practiced by those skilled in the art without departing from the scope and spirit of the invention. It should therefore be understood that the scope of the appended claims is not intended to be limited by the details of the description but should rather be broadly construed.

What is claimed is:

1. A liquid crystal display apparatus comprising: a liquid crystal cell including a pair of substrates provided with a color filter on one substrate, and a liquid crystal layer as a display medium arranged between the substrates; and an optical compensation element including at least an optical compensation layer, wherein the optical compensation element is arranged only on the same side as the color filter with respect to the liquid crystal layer; the color filter and the optical compensation element are both arranged on a viewer side; the substrate provided with the color filter has a haze value of 10% or less; the liquid crystal cell employs a VA mode; the optical compensation layer has an Nz coefficient of 2 to 6; and the optical compensation layer has a refractive index profile of  $n_x > n_y > n_z$ .
2. A liquid crystal display apparatus according to claim 1, wherein the optical compensation layer is formed from a non-liquid crystalline material.
3. A liquid crystal display apparatus according to claim 2, wherein the non-liquid crystalline material comprises at least one polymer selected from the group consisting of polyimide, polyamide, polyester, polyetherketone, polyamideimide, and polyesterimide.
4. A liquid crystal display apparatus according to claim 3, wherein the non-liquid crystalline material comprises polyimide.
5. A liquid crystal display apparatus according to claim 1, wherein the optical compensation layer has an in-plane retardation

And of 5 nm or more and 400 nm or less, and a thickness retardation Rth of 10 nm or more and 1,000 nm or less.

6. A liquid crystal display apparatus according to claim 1, wherein the optical compensation layer has a thickness of 1 to 20 μm.

7. A liquid crystal display apparatus according to claim 1, wherein the optical compensation layer is a monolayer.

8. A liquid crystal display apparatus comprising: a liquid crystal cell including a pair of substrates provided with a color filter on one substrate, and a liquid crystal layer as a display medium arranged between the substrates;

an optical compensation element including at least an optical compensation layer and arranged on the same side as the color filter with respect to the liquid crystal layer;

a pair of polarizing plates respectively arranged on an outer side of the optical compensation element and on a side of the liquid crystal cell on which the optical compensation element is not arranged; and

a light source provided on an opposite side of the optical compensation element with respect to the liquid crystal cell,

wherein the color filter and the optical compensation element are both arranged only on a viewer side;

the substrate provided with the color filter has a haze value of 10% or less;

the liquid crystal cell employs a VA mode;

the optical compensation layer has an Nz coefficient of 2 to 6; and

the optical compensation layer has a refractive index profile of  $n_x > n_y > n_z$ .

9. A liquid crystal display apparatus according to claim 8, wherein the color filter is structured to inhibit light scattering from the light source.

10. A liquid crystal display apparatus comprising:

a liquid crystal cell including a pair of substrates provided with a color filter on one substrate, and a liquid crystal layer as a display medium arranged between the substrates;

an optical compensation element including an optical compensation layer and a polarizer arranged on the same side as the color filter with respect to the liquid crystal layer; and

a polarizing plate provided on a side of the liquid crystal cell on which the optical compensation element is not arranged,

wherein the color filter and the optical compensation element are both arranged only on a viewer side;

the substrate provided with the color filter has a haze value of 10% or less;

the liquid crystal cell employs a VA mode;

the optical compensation layer has an Nz coefficient of 2 to 6; and

the optical compensation layer has a refractive index profile of  $n_x > n_y > n_z$ .

11. A liquid crystal display apparatus according to claim 10, wherein the optical compensation element has a slow axis of the optical compensation layer that is perpendicular to an absorption axis of the polarizer.

\* \* \* \* \*

专利名称(译)	液晶显示装置		
公开(公告)号	<a href="#">US8184244</a>	公开(公告)日	2012-05-22
申请号	US11/084199	申请日	2005-03-21
[标]申请(专利权)人(译)	日东电工株式会社		
申请(专利权)人(译)	日东电工株式会社		
当前申请(专利权)人(译)	日东电工株式会社		
[标]发明人	UEDA NARIFUMI MURAKAMI NAO YOSHIMI HIROYUKI		
发明人	UEDA, NARIFUMI MURAKAMI, NAO YOSHIMI, HIROYUKI		
IPC分类号	G02F1/1335 G02B5/30 G02F1/13363 G02F1/139		
CPC分类号	G02F1/133514 G02F1/13363 G02F1/133634 G02F1/1393 G02F1/1395 G02F2001/13356 G02F2001/133562 G02F2202/40 G02F2413/01		
优先权	2005027692 2005-02-03 JP 2005016282 2005-01-25 JP		
其他公开文献	US20060164580A1		
外部链接	<a href="#">Espacenet</a> <a href="#">USPTO</a>		

摘要(译)

本发明的液晶显示装置包括：液晶单元，包括：一对基板，在一个基板上设置有滤色器；以及液晶层，作为设置在基板之间的显示介质；光学补偿元件至少包括光学补偿层。光学补偿元件相对于液晶层布置在与滤色器相同的一侧。具有滤色器的基板优选具有10%或更低的雾度值。这种液晶显示装置允许优异的视角补偿，在倾斜方向上呈现出优异的对比值，并且可以减小厚度。

