



US007898607B2

(12) **United States Patent**
Su et al.

(10) **Patent No.:** **US 7,898,607 B2**
(45) **Date of Patent:** **Mar. 1, 2011**

(54) **LIQUID CRYSTAL DISPLAY AND DRIVING METHOD THEREOF**

(75) Inventors: **Jenn-Jia Su**, Hsin-Chu (TW);
Ming-Feng Tien, Hsin-Chu (TW);
Ting-Jui Chang, Hsin-Chu (TW);
Po-Lun Chen, Hsin-Chu (TW)

(73) Assignee: **Au Optronics Corp.**, Hsin-Chu (TW)

(*) Notice: Subject to any disclaimer, the term of this patent is extended or adjusted under 35 U.S.C. 154(b) by 0 days.

7,429,981 B2	9/2008	Shimoshikiryo
7,812,896 B2 *	10/2010	Su et al. 349/48
2003/0227429 A1	12/2003	Shimoshikiryo
2004/0001167 A1	1/2004	Takeuchi et al.
2005/0030460 A1	2/2005	Kim et al.
2005/0122441 A1	6/2005	Shimoshikiryo
2005/0253797 A1	11/2005	Kamada et al.
2006/0215066 A1	9/2006	Ueda et al.
2007/0002194 A1	1/2007	Shin
2007/0057297 A1	3/2007	Kim
2008/0007506 A1	1/2008	Chen et al.

(21) Appl. No.: **12/795,995**

(22) Filed: **Jun. 8, 2010**

(65) **Prior Publication Data**

US 2010/0245696 A1 Sep. 30, 2010

Related U.S. Application Data

(63) Continuation of application No. 11/682,003, filed on Mar. 5, 2007, now Pat. No. 7,812,896.

(30) **Foreign Application Priority Data**

Sep. 8, 2006 (TW) 95133352 A

(51) **Int. Cl.**
G02F 1/1343 (2006.01)

(52) **U.S. Cl.** 349/38; 349/48; 349/144

(58) **Field of Classification Search** None
See application file for complete search history.

(56) **References Cited**

U.S. PATENT DOCUMENTS

5,808,706 A	9/1998	Bae
5,923,310 A	7/1999	Kim
6,680,722 B1	1/2004	Hiraki et al.
6,958,791 B2	10/2005	Shimoshikiryo

FOREIGN PATENT DOCUMENTS

CN	1764865	4/2006
CN	1800953	7/2006

(Continued)

Primary Examiner—Mike Stahl

(74) *Attorney, Agent, or Firm*—Thomas, Kayden, Horstemeyer & Risley

(57) **ABSTRACT**

A liquid crystal display includes a gate driver, a data driver and a pixel matrix. The gate driver is for outputting a plurality of gate signals successively. The data driver is for providing a plurality of data signals. The pixel matrix includes a number of pixels. Each pixel includes a first sub-pixel, a second sub-pixel and a voltage coupling device. The voltage coupling device is coupled between the first sub-pixel and the second sub-pixel such that pixel voltages of the first sub-pixel and the second sub-pixel are different and have relevant variation.

10 Claims, 10 Drawing Sheets

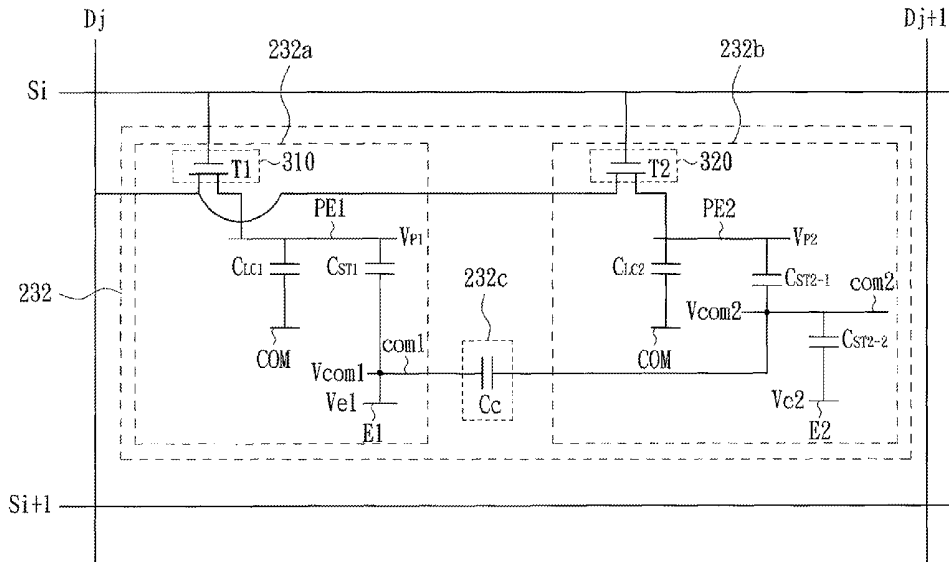

US 7,898,607 B2

Page 2

FOREIGN PATENT DOCUMENTS		
CN	1821842	8/2006
JP	08179278	7/1996
JP	2000147462	5/2000
JP	2002165185	6/2002
JP	2003105334	4/2003
KR	1020030042221	5/2003
TW	I240103	9/2005
TW	200628942	8/2006
WO	WO 2004/086129	10/2004

* cited by examiner

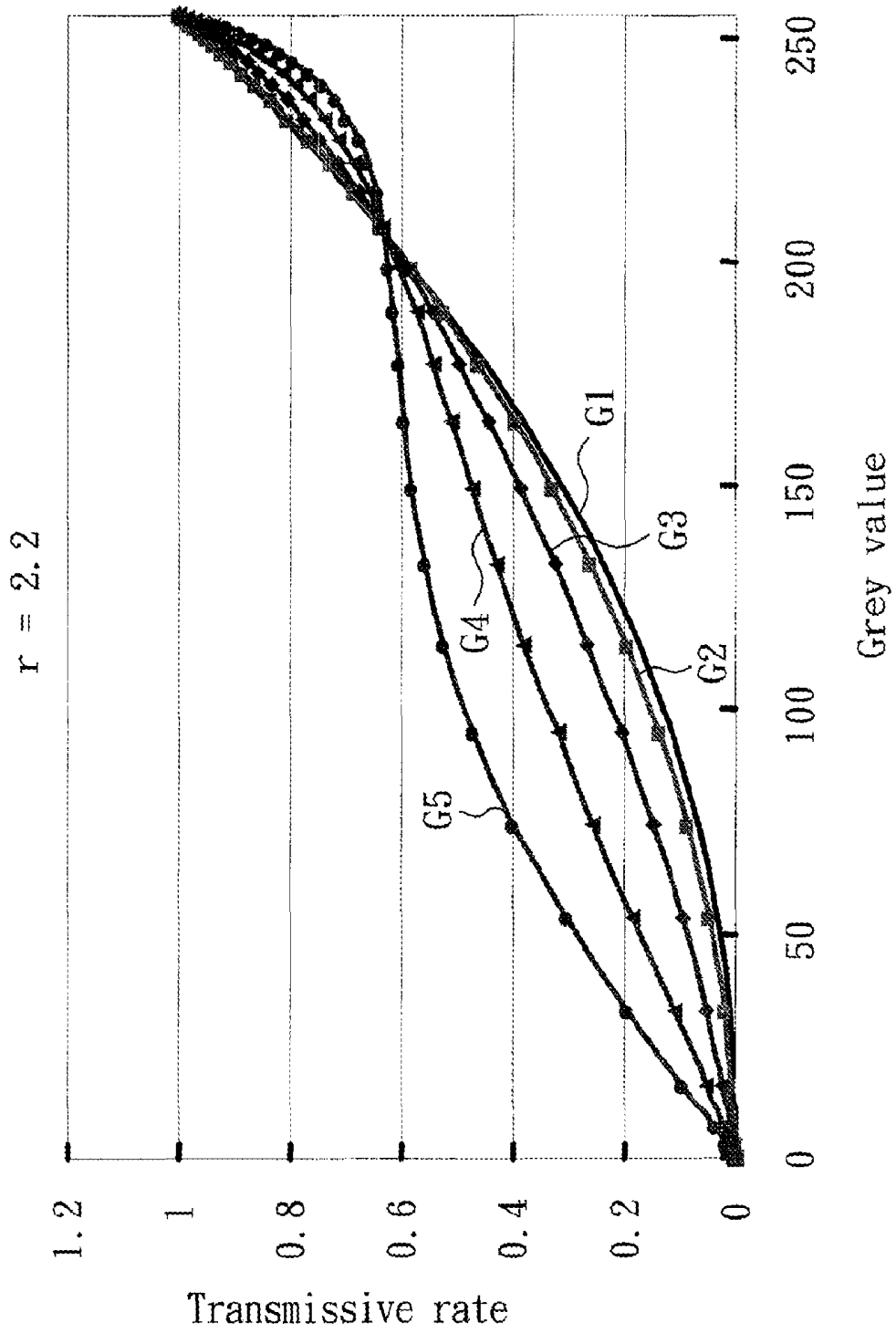

FIG. 1 (RELATED ART)

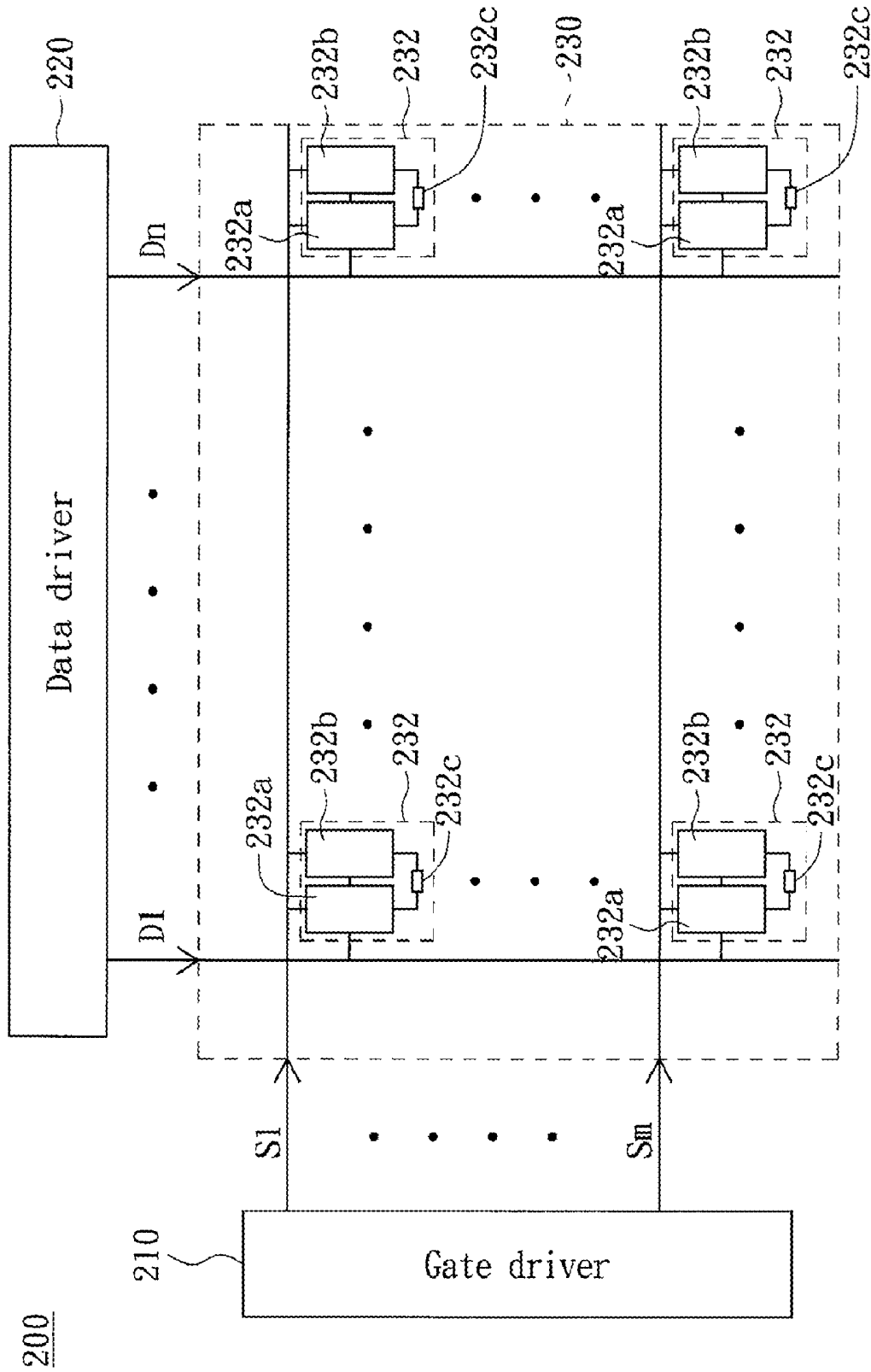

FIG. 2

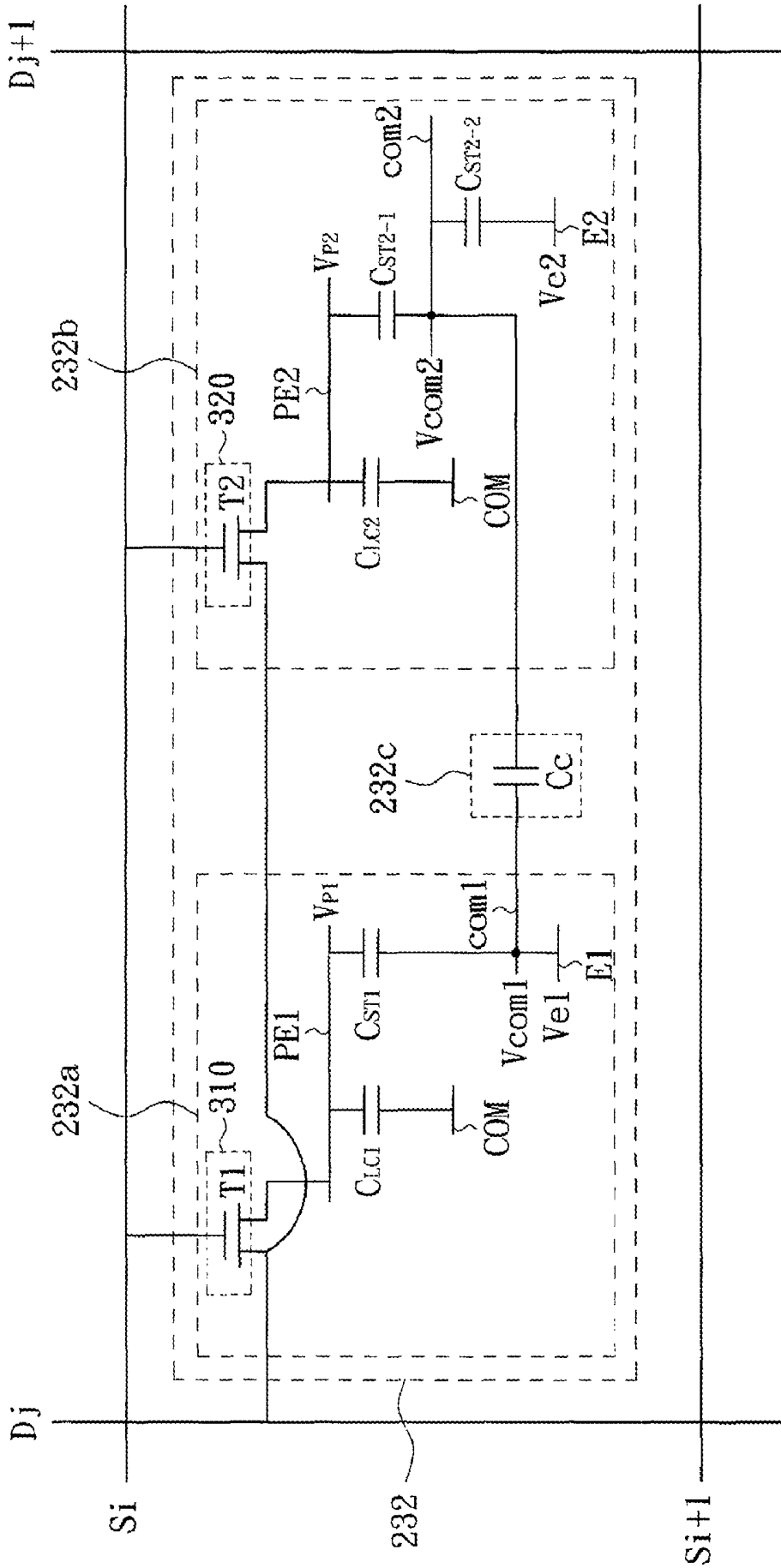

FIG. 3

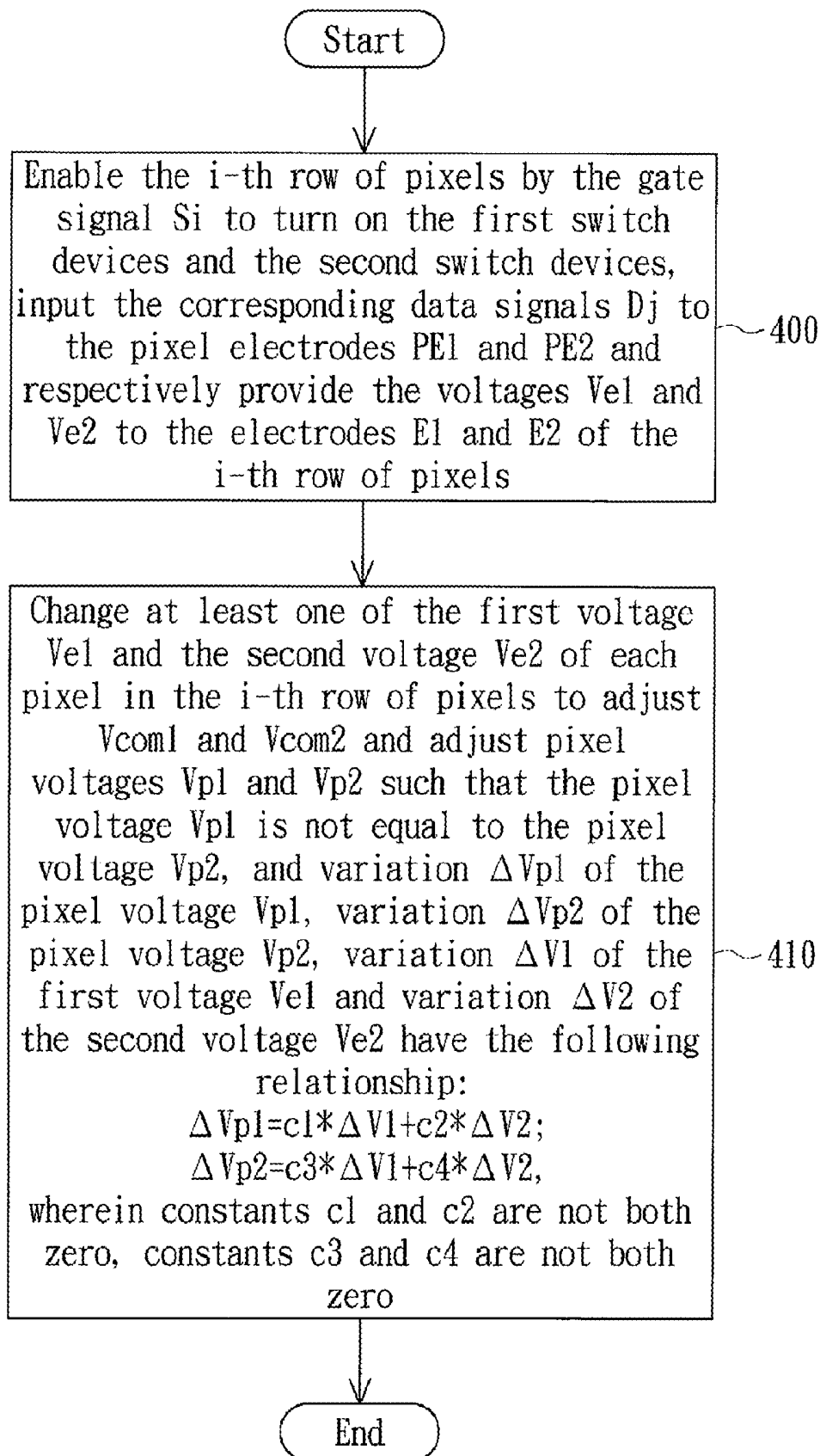

FIG. 4

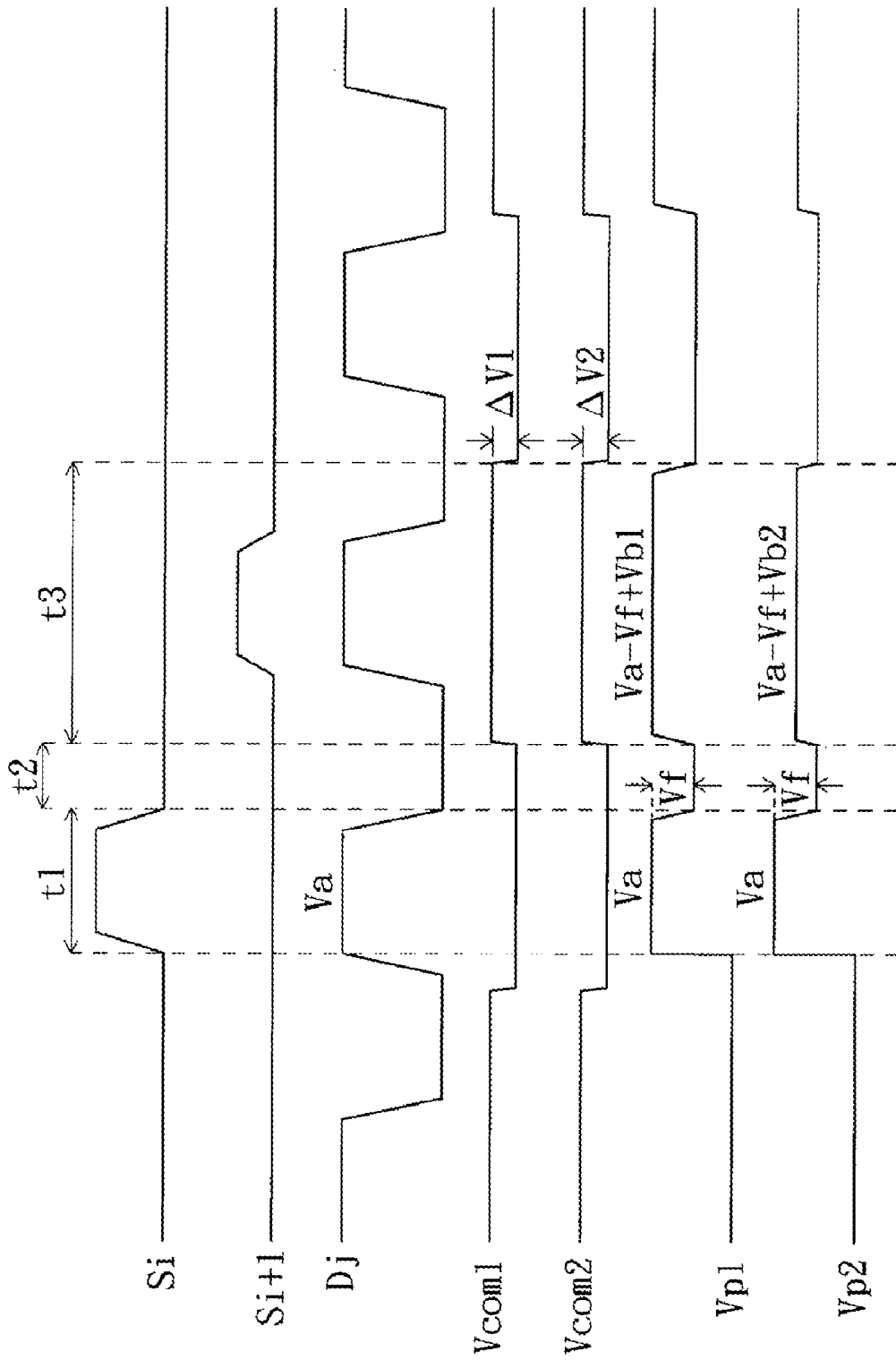

FIG. 5

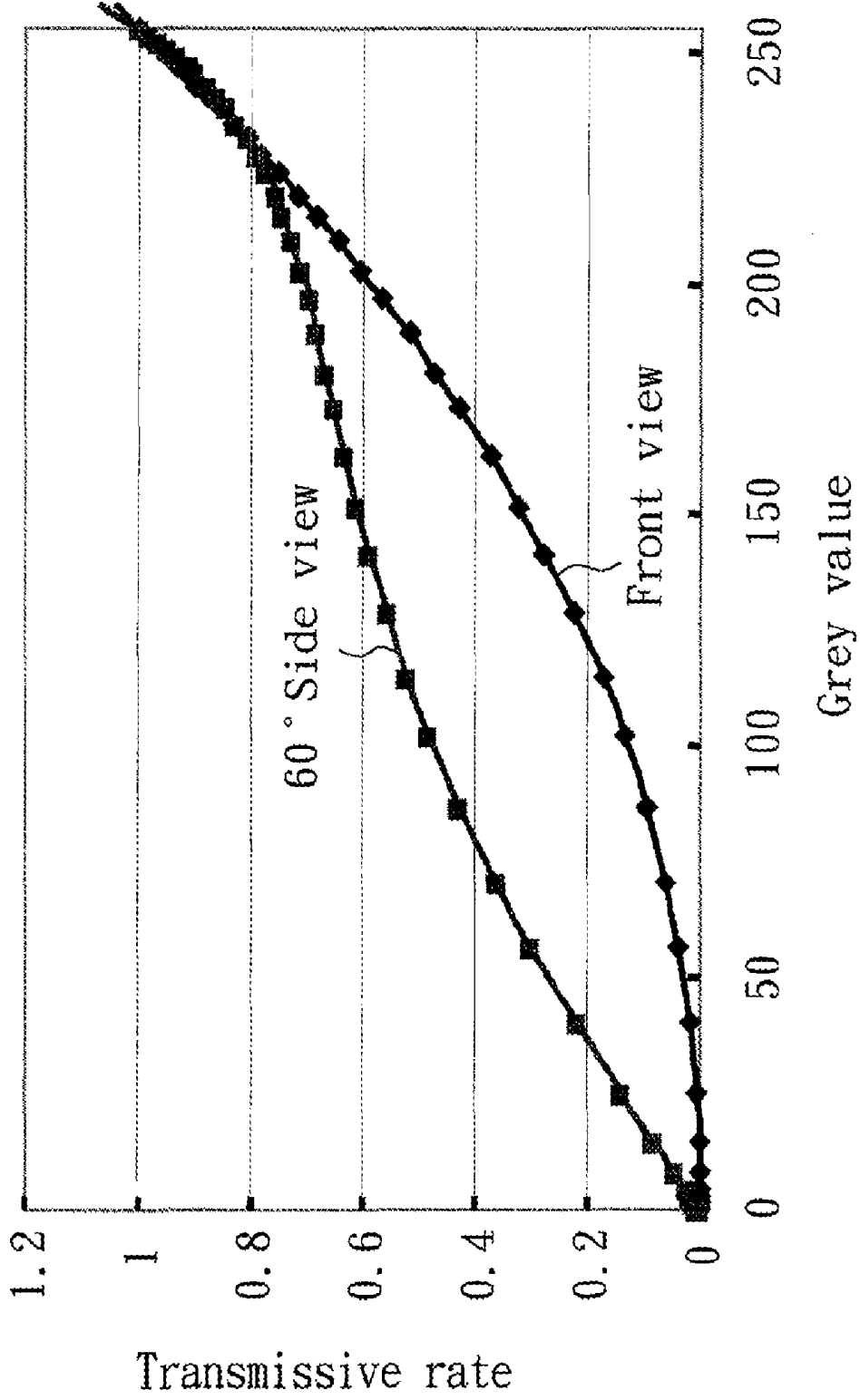

FIG. 6A

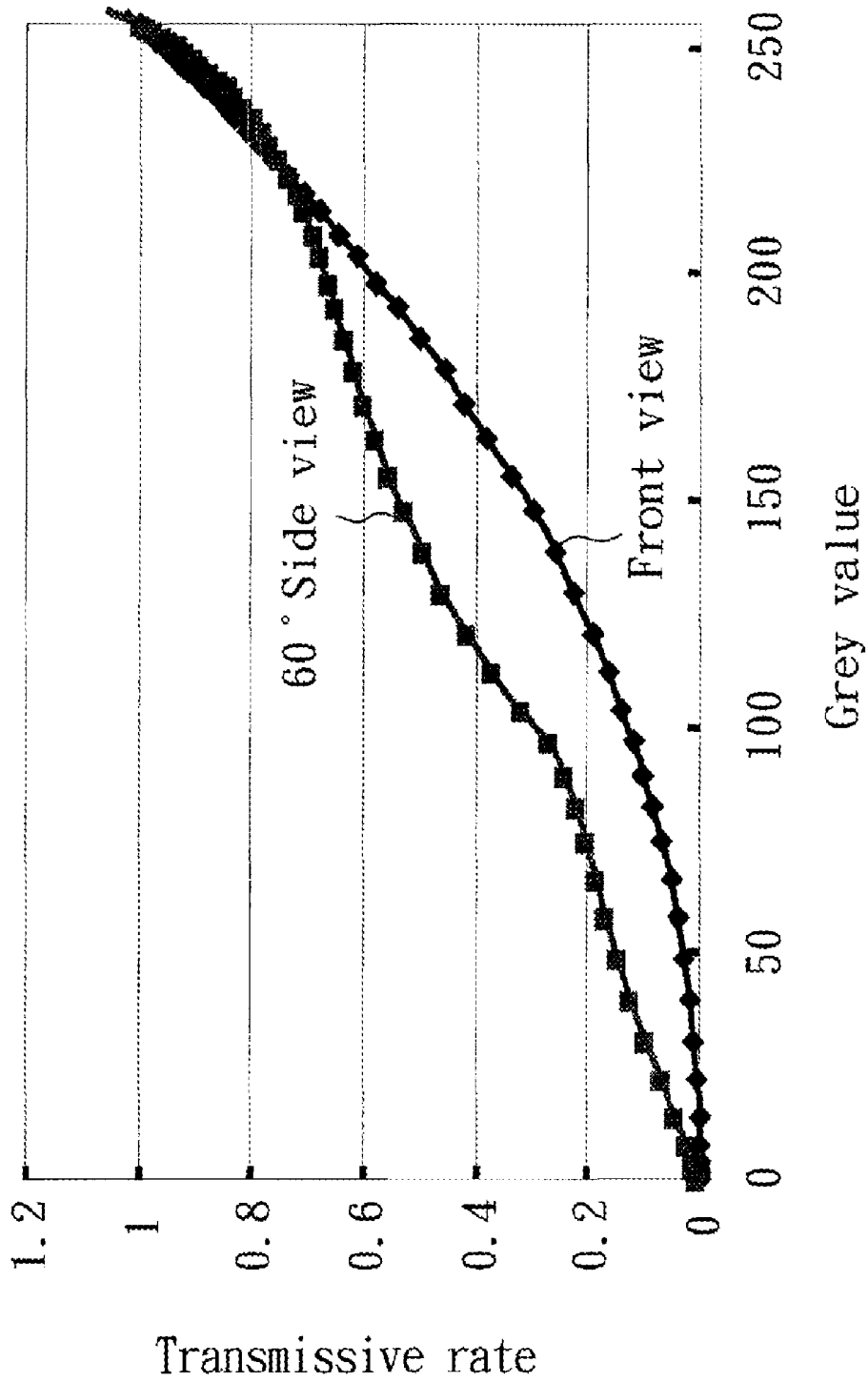

FIG. 6B

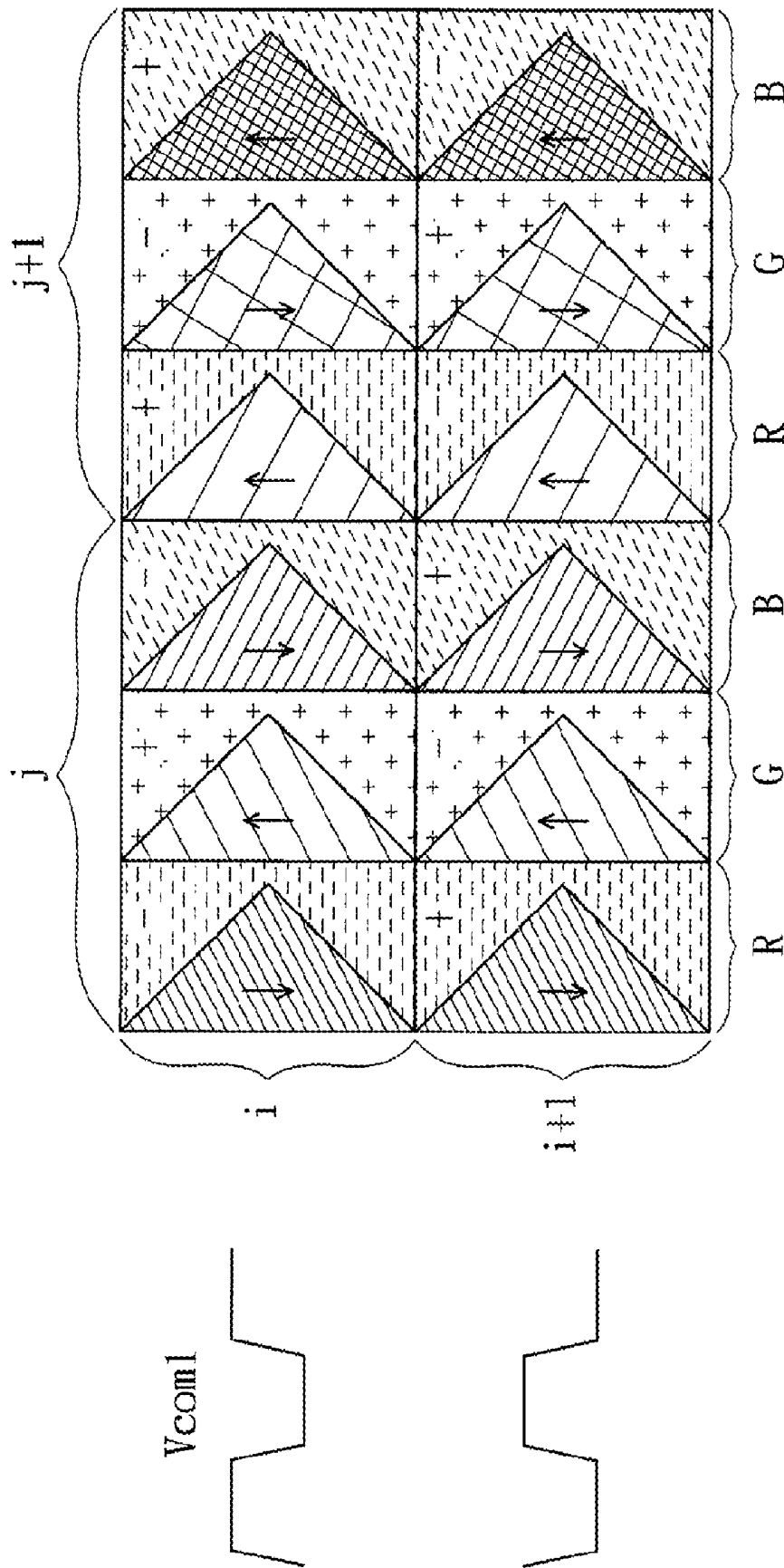

FIG. 7

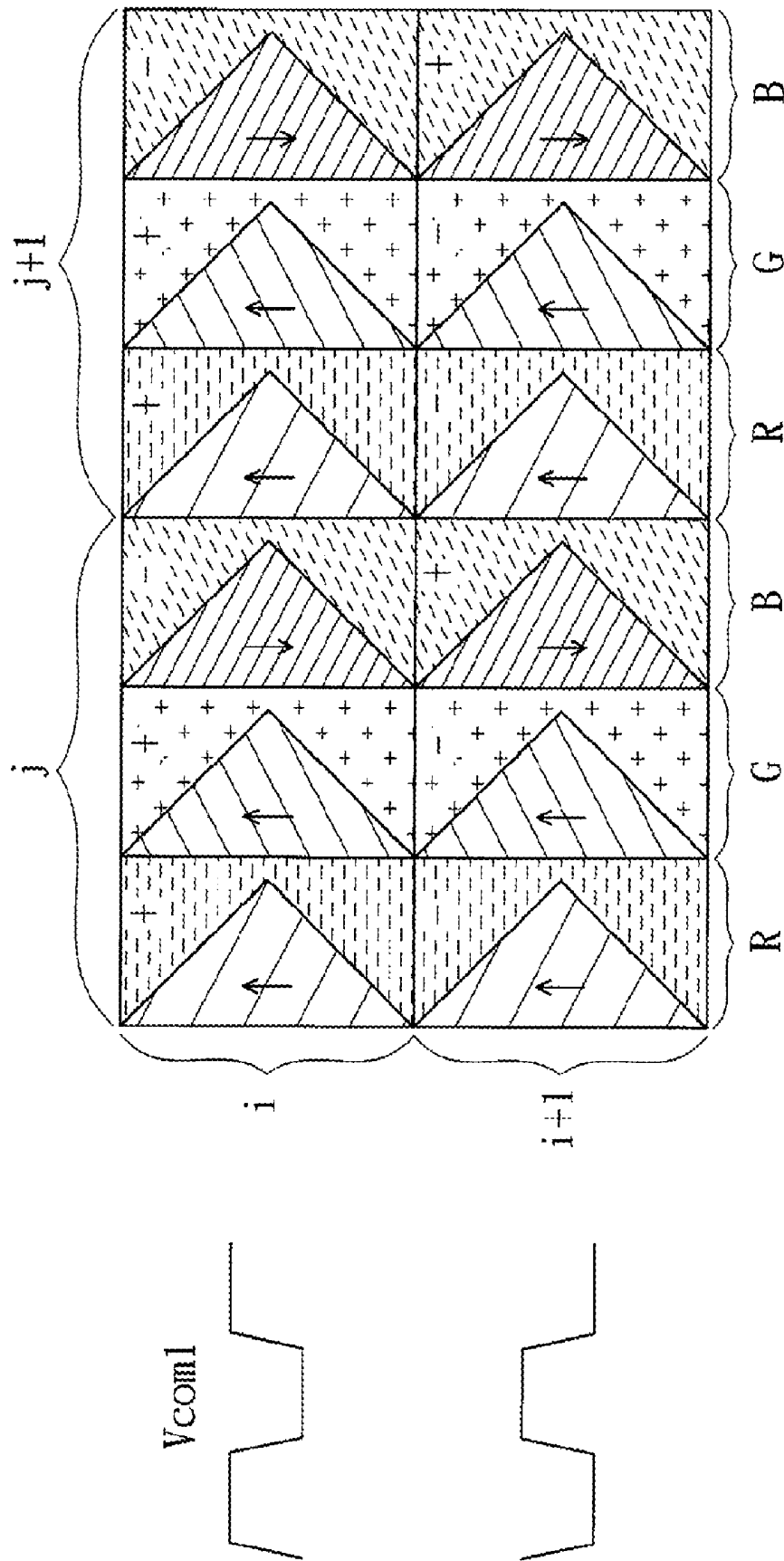

FIG. 8

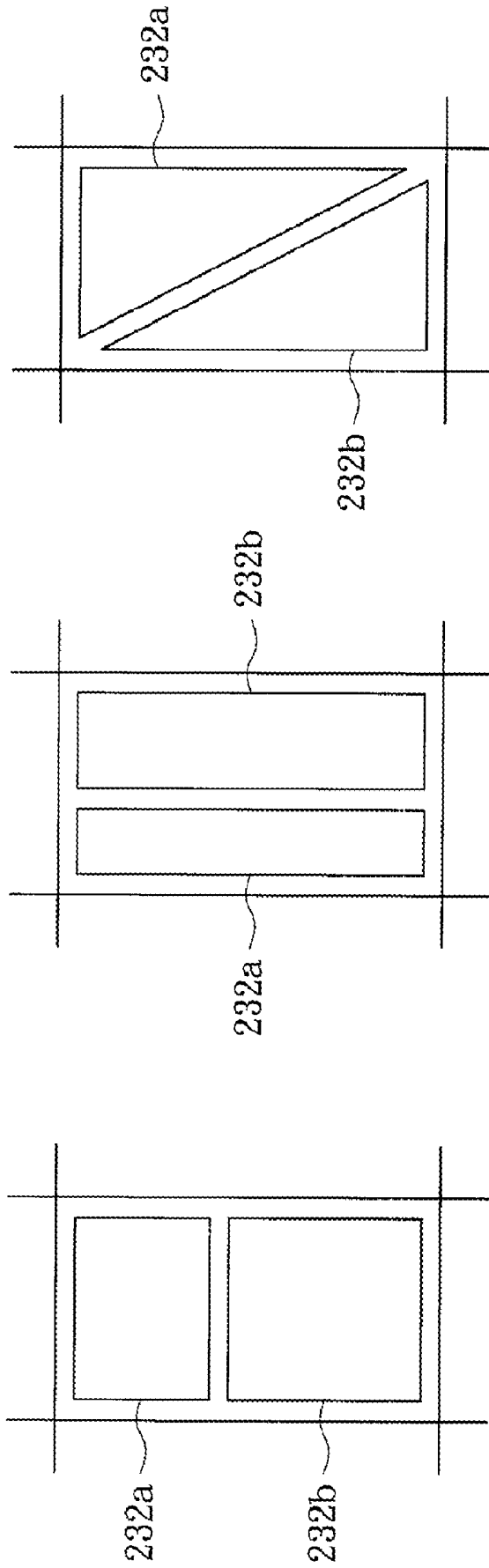

FIG. 9

LIQUID CRYSTAL DISPLAY AND DRIVING METHOD THEREOF

This application is a continual application of co-pending application Ser. No. 11/682,003, filed on Mar. 5, 2007, which claims priority to Taiwanese application number 95133352, filed Sep. 8, 2006, both of which are incorporated herein by reference.

BACKGROUND OF THE INVENTION

1. Field of the Invention

The invention relates in general to a liquid crystal display (LCD) and driving method thereof, and more particularly to a liquid crystal display having two driving voltages for each pixel and driving method thereof.

2. Description of the Related Art

In a conventional liquid crystal display, each pixel uses only a driving voltage, which easily results in a color-deviation issue as a viewing angle varies. Referring to FIG. 1, gamma curves of a conventional multi-domain vertical alignment (MVA)-type liquid crystal display as displayed in several viewing angles are shown, wherein the gamma coefficient r is 2.2. The curve G1 is a gamma curve of the display observed at a front view, while the curves G2-G5 are respectively gamma curves of the display observed at a viewing angle of 15, 30, 45 and 60 degrees. From FIG. 1, due to difference of the gamma curves at a front view and side view, corresponding to the same grey value, a light transmissive rate of liquid crystals at a front view and side view are also different. Therefore, images may have color variation as displayed at different viewing angles, which is called a color-deviation phenomenon.

SUMMARY OF THE INVENTION

It is therefore an object of the invention to provide a liquid crystal display and driving method thereof. Each pixel includes two sub-pixels and each sub-pixel has a driving voltage. The two sub-pixels have different liquid-crystal tilt angles, and thus optical effect in the two regions can compensate to each other. Besides, variations of the two pixel voltages are relevant. Therefore, the above color-deviation issue can be eliminated and image quality of the liquid crystal display can be improved.

The invention achieves the above-identified object by providing a liquid crystal display including a gate driver, a data driver and a pixel matrix. The gate driver is for outputting a plurality of gate signals successively. The data driver is for providing a plurality of data signals. The pixel matrix includes a number of pixels coupled to the gate driver and the data driver. Each of the pixels includes a first sub-pixel, a second sub-pixel and a voltage coupling device. The first sub-pixel includes a first switch device, a first pixel electrode, a first electrode, a first common electrode, and a first storage capacitor.

The first switch device is for outputting the corresponding data signal according to the corresponding gate signal. The first pixel electrode is coupled to the first switch device for receiving the data signal. The first electrode is for providing a first voltage. The first storage capacitor is formed between the first pixel electrode and the first common electrode. The second sub-pixel includes a second switch device, a second pixel electrode, a second electrode, a second common electrode and a second storage capacitor. The second switch device is for outputting the corresponding data signal according to the corresponding gate signal. The second pixel electrode is

coupled to the second switch device for receiving the data signal. The second electrode is for providing a second voltage. The second storage capacitor is formed between the second pixel electrode and the second common electrode. The voltage coupling device is coupled between the first sub-pixel and the second sub-pixel such that the first common electrode is electrically related to the second common electrode.

The invention achieves the above-identified object by providing a method for driving a liquid crystal display. The liquid crystal display includes a gate driver, a data driver and several rows of pixels. The gate driver outputs a number of gate signals, and the data driver outputs a number of data signals. Each of the pixels includes a first sub-pixel and a second sub-pixel. The first sub-pixel has a first switch device, a first pixel electrode, a first common electrode and a first electrode. The first pixel electrode and the first common electrode form a first storage capacitor. The second sub-pixel has a second switch device, a second pixel electrode, a second common electrode and a second electrode. The second pixel electrode and the second common electrode form a second storage capacitor.

The method includes (a) enabling a row of pixels according to the corresponding gate signal to turn on the first switch device and the second switch device of each pixel in the row of pixels, inputting the corresponding data signal to the first pixel electrode and the second pixel electrode and respectively providing a first voltage and a second voltage to the first electrodes and the second electrodes in the row of pixels; and (b) after the gate signal is stopped outputting for a period of time, changing at least one of the first voltage and the second voltage of each pixel in the row of pixels to adjust voltages of the corresponding first pixel electrode and the second pixel electrode such that the voltage of the first pixel electrode is not equal to the voltage of the second pixel electrode, wherein voltage variation ΔV_{p1} of the first pixel electrode, voltage variation ΔV_{p2} of the second pixel electrode, variation $\Delta V1$ of the first voltage and variation $\Delta V2$ of the second voltage have the following relationship: $\Delta V_{p1} = c1 * \Delta V1 + c2 * \Delta V2$; $\Delta V_{p2} = c3 * \Delta V1 + c4 * \Delta V2$, and constants $c1$ and $c2$ are not both zero, constants $c3$ and $c4$ are not both zero.

Other objects, features, and advantages of the invention will become apparent from the following detailed description of the preferred but non-limiting embodiments. The following description is made with reference to the accompanying drawings.

BRIEF DESCRIPTION OF THE DRAWINGS

FIG. 1 is gamma curves of a conventional MVA-type liquid crystal display as displayed in several viewing angles.

FIG. 2 is a schematic diagram of a liquid crystal display structure according to a preferred embodiment of the invention.

FIG. 3 is a schematic diagram of a circuit structure of the (i, j)-th pixel in FIG. 2.

FIG. 4 is a flow chart of a method for driving a liquid crystal display according to a preferred embodiment of the invention.

FIG. 5 is a timing diagram of the gate signal S_i , data signal D_j , first common-electrode voltage V_{com1} , second common-electrode voltage V_{com2} , and pixel voltages V_{p1} and V_{p2} in FIG. 3.

FIG. 6A is gamma curves of a conventional liquid crystal display using only a driving voltage for each pixel as displayed at a front view and 60-degree side view.

FIG. 6B is gamma curves of the liquid crystal display of the invention using two driving voltages for each pixel 232 as displayed at a front view and 60-degree side view.

FIG. 7 is a schematic diagram of a panel driving method according to the preferred embodiment of the invention.

FIG. 8 shows another panel driving method according to the preferred embodiment of the invention.

FIG. 9 is a schematic diagram of arrangement patterns of the first sub-pixel and the second sub-pixel according to the preferred embodiment of the invention.

DETAILED DESCRIPTION OF THE INVENTION

Referring to FIG. 2, a schematic diagram of a liquid crystal display structure according to a preferred embodiment of the invention is shown. A liquid crystal display 200, such as a MVA-type liquid crystal display, includes a gate driver 210, a data driver 220 and a pixel matrix 230. The gate driver 210 is for successively outputting m gate signals $S1\sim Sm$ to the pixel matrix 230 and the data driver 220 is for providing n data signals $D1\sim Dn$ to the pixel matrix 230, wherein m and n are positive integers. The pixel matrix 230 includes $m*n$ pixels 232, and each pixel 232 includes a first sub-pixel 232a, a second sub-pixel 232b and a voltage coupling device 232c. The first sub-pixel 232a and the second sub-pixel 232b receive the same data signal Dj ($j=1\sim n$) according to the gate signal Si ($i=1\sim m$). The voltage coupling device 232c is coupled to the first sub-pixel 232a and the second sub-pixel 232b such that variations of pixel voltages of the first sub-pixel 232a and the second sub-pixel 232b are relevant.

Referring to FIG. 3, a schematic diagram of a circuit structure of the (i, j) -th pixel 232 in FIG. 2 is shown. As shown in FIG. 3, the first sub-pixel 232a of the (i, j) -th pixel 232 includes a first switch device 310, a first pixel electrode PE1, a first common electrode com1, a first electrode E1, a first liquid crystal capacitor C_{LC1} and a first storage capacitor C_{ST1} . The first switch device 310, such as a thin film transistor (TFT) T1, is for outputting the corresponding data signal Dj according to control of the i -th gate signal Si . In the embodiment, the first switch device 310 is exemplified to be an N-type metal oxide semiconductor (NMOS) transistor for illustration. The transistor T1 has a gate for receiving the gate signal Si , a source for receiving the data signal Dj and a drain for outputting the data signal Dj .

The first pixel electrode PE1 is coupled to the drain of the first switch device (transistor T1) for receiving the data signal Dj . A liquid crystal layer (not shown in the figure) is disposed between the first pixel electrode PE1 and a common electrode COM on an upper substrate to form the first liquid crystal capacitor C_{LC1} . An insulation layer (not shown in the figure) is disposed between the first pixel electrode PE1 and the first common electrode com1 to form the first storage capacitor C_{ST1} . The first electrode E1 is coupled to the first common electrode com1 and the first electrode E1 is for providing a voltage $Ve1$. For example, the voltage $Ve1$ has a swing-type waveform and a voltage $Vcom1$ of the first common electrode com1 has also a swing-type waveform with the same amplitude as the voltage $Ve1$ of the first electrode E1. Of course, in practical application, the first common-electrode voltage $Vcom1$ can also be provided directly by the first common electrode com1.

The second sub-pixel 232b includes a second switch device 320, a second pixel electrode PE2, a second common electrode com2, a second electrode E2, a second liquid crystal capacitor C_{LC2} , a second storage capacitor C_{ST2-1} and a third storage capacitor C_{ST2-2} . The second switch device 320, such as a TFT T2, is for outputting the corresponding data signal Dj

according to control of the corresponding i -th gate signal Si . In the embodiment, the second switch device 320 is exemplified to be a NMOS transistor. The transistor T2 has a gate for receiving the gate signal Si , a source for receiving the data signal Dj and a drain for outputting the data signal Dj .

The second pixel electrode PE2 is coupled to a drain of the second switch device (transistor T2) 320 for receiving the data signal Sj . A liquid crystal layer (not shown in the figure) is disposed between the second pixel electrode PE2 and the common electrode COM on the upper substrate to form the second liquid crystal capacitor C_{LC2} . An insulation layer (not shown in the figure) is disposed between the second pixel electrode PE2 and the second common electrode com2 to form the second storage capacitor C_{ST2-1} . The second common electrode com2, such as a lower substrate, has a second common voltage $Vcom2$. Another insulation layer (not shown in the figure) is disposed between the second electrode E2 and the second common electrode com2 to form the third storage capacitor CST2-2. The second electrode E2 is for providing a voltage $Ve2$, such as a constant voltage. The voltage $Ve2$ can be provided by a gate line near the (i, j) -th pixel 232 to reduce a number of electrodes in transverse and thus increase an opening ratio.

Besides, the voltage coupling device 232c, such as a capacitor Cc , is coupled to the first common voltage com1 and the second common electrode com2 such that variations of the first common-electrode voltage $Vcom1$ and the second common-electrode voltage $Vcom2$ are relevant to each other. As mentioned above, the first common-electrode voltage $Vcom1$ behaves in a swing type and thus the voltage $Vcom2$ also behaves in a swing type but with smaller amplitude. Due to an effect of the first storage capacitor C_{ST1} and the second storage capacitor C_{ST2-1} , the pixel voltage $Vp1$ of the first pixel electrode E1 and the pixel voltage $Vp2$ of the second pixel electrode PE2 have relevant variation.

Referring to FIG. 4, a flow chart of a method for driving a liquid crystal display according to a preferred embodiment of the invention is shown. First, in step 400, in a timing duration $t1$, enable the i -th row of pixels 232 by the gate signal Si ($i=1\sim m$) to turn on the first switch devices 310 and the second switch devices 320 in the i -th row of pixels 232, input the corresponding data signals Dj ($j=1\sim n$) to the first pixel electrodes PE1 and second pixel electrode PE2 and respectively provide the first voltage $Ve1$ and the second voltage $Ve2$ to the first electrodes E1 and second electrodes E2 of the i -th row of pixels 232.

Afterwards, in step 410, after the gate signal Si is stopped outputting for a period of time $t2$, in a timing duration $t3$, change at least one of the first voltage $Ve1$ and the second voltage $Ve2$ of each pixel 232 in the i -th row of pixels 232 to adjust the first common-electrode voltage $Vcom1$ and the second common-electrode voltage $Vcom2$ and adjust a pixel voltage $Vp1$ of the corresponding first pixel electrode PE1 and a pixel voltage $Vp2$ of the corresponding second pixel electrode PE2 such that the pixel voltage $Vp1$ is not equal to the pixel voltage $Vp2$, and variation $\Delta Vp1$ of the pixel voltage $Vp1$, variation $\Delta Vp2$ of the pixel voltage $Vp2$, variation $\Delta V1$ of the first voltage $Ve1$ and variation $\Delta V2$ of the second voltage $Ve2$ have the following relationship: $\Delta Vp1=c1*\Delta V1+c2*\Delta V2$; $\Delta Vp2=c3*\Delta V1+c4*\Delta V2$, and constants $c1$ and $c2$ are not both zero, constants $c3$ and $c4$ are not both zero.

In the embodiment, the first voltage $Ve1$ or the first common-electrode voltage $Vcom1$ is altered in a swing type and the second common-electrode voltage $Vcom2$ is adjusted by an effect of the voltage coupling device 232c (the capacitor Cc) such that variations of the pixel voltages $Vp1$ and $Vp2$ are both relevant to variations of the first voltage $Ve1$ and the

5

second voltage V_{e2} and thus variations of the pixel voltages V_{p1} and V_{p2} are relevant to each other. In the following description, a signal timing diagram is used to illustrate how the pixel voltages V_{p1} and V_{p2} are changing in accordance with variation of the first voltage V_{e1} and the second voltage V_{e2} .

Referring to FIG. 5, a timing diagram of the gate signal S_i , data signal D_j , first common-electrode voltage V_{com1} , second common-electrode voltage V_{com2} , and pixel voltages V_{p1} and V_{p2} in FIG. 3 is shown, wherein pixels are driven in a positive direction in the embodiment. In the timing duration t_1 , the gate signal S_i with a high voltage level turns on the first switch device **310** of the first sub-pixel **232a** and the second switch device **320** of the second sub-pixel **232b** and the data signal D_j is transmitted to the first pixel electrode PE1 and the second pixel electrode PE2 respectively via the first switch device **310** and the second switch device **320**. The first voltage V_{e1} and the second voltage V_{e2} both have a low level, that is, the first common-electrode voltage V_{com1} and the second common-electrode voltage V_{com2} are both at a low level. At the time, the pixel voltages V_{p1} and V_{p2} are approximately equal to the voltage level V_a of the data signal D_j . Following that, in the timing duration t_2 , the first common-electrode voltage V_{com1} and the second common-electrode voltage V_{com2} remain at the low level. The gate signal S_i has an output of a low voltage level such that the first switch device **310** and the second switch device **320** are both turned off. At the time, due to an effect of a parasitic capacitor C_{gs} (not shown in the figure) of the first pixel electrode PE1 and the second pixel electrode PE2, the pixel voltages V_{p1} and V_{p2} are lowered down by a feed-through voltage V_f from an original value V_a .

Afterwards, in the timing duration t_3 , the first voltage V_{e1} or the first common-electrode voltage V_{com1} is increased by a value ΔV_1 to a high level. The second voltage V_{e2} remains unchanged and due to a coupling effect of the voltage coupling device **232c**, the second common-electrode voltage V_{com2} is increased by a value ΔV_2 ($<\Delta V_1$), wherein

$$\Delta V_2 = \frac{C_c}{C_{ST2} - 2 + C_c + C_{ST2} - 1 // C_{LC2}} \times \Delta V_1.$$

Due to the effect of the first storage capacitor C_{ST1} and the second storage capacitor C_{ST2-1} , the voltage V_{p1} of the first pixel electrode PE1 is increased to

$$\left(V_a - V_f + \frac{C_{ST1}}{C_{ST1} + C_{LC1}} \times \Delta V_1 \right) = V_a - V_f + V_{b1},$$

wherein

$$V_{b1} = \frac{C_{ST1}}{C_{ST1} + C_{LC1}} \times \Delta V_1.$$

The voltage V_{p2} of the second pixel electrode PE2 is accordingly increased to

6

$$\left(V_a - V_f + \frac{C_{ST2-1}}{C_{ST2-1} + C_{LC2}} \times \Delta V_2 \right) = V_a - V_f + V_{b2},$$

wherein

$$V_{b2} = \frac{C_{ST2-1}}{C_{ST2-1} + C_{LC2}} \times \Delta V_2.$$

As corresponding to the variation ΔV_{p1} of the above pixel voltage V_{p1} which is equal to $c_1 \times \Delta V_1 + c_2 \times \Delta V_2$, the constant

$$c_1 = \frac{C_{ST1}}{C_{ST1} + C_{LC1}}$$

and $c_2 = 0$. As corresponding to the variation ΔV_{p2} of the above pixel voltage V_{p2} which is equal to $c_3 \times \Delta V_1 + c_4 \times \Delta V_2$, the constant $c_3 = 0$ and

$$c_4 = \frac{C_{ST2-1}}{C_{ST2-1} + C_{LC2}}.$$

Therefore, in the following timing duration, the pixel voltages V_{p1} and V_{p2} vary in a swing type in accordance with the first common-electrode voltage V_{com1} and the second common-electrode voltage V_{com2} . When the swing period of the first common-electrode voltage V_{com1} is much smaller than a frame time (such as 16.6 ms) of the liquid crystal display **200**, that is, a ratio of the swing period of the first common-electrode voltage V_{com1} and the frame time is smaller than $1/10$, owing that liquid crystals have a smaller response speed and thus cannot feel a high-low variation of the first common-electrode voltage V_{com1} , the voltage felt by the liquid crystals is a root-mean-square value (V_{rms}) of the common-electrode voltage V_{com1} . By adjusting the swing amplitude of the first common-electrode voltage V_{com1} , a different root-mean-square value is obtained, that is, the liquid crystals can feel a different voltage drop.

According to design of the liquid crystal display **200** in the embodiment, a liquid crystal layer of each pixel **232** can feel two different voltage drops ($V_{p1} - V_{COM}$) and ($V_{p2} - V_{COM}$), thereby reducing the above color deviation issue. Referring to FIG. 6A and FIG. 6B, gamma curves of a conventional liquid crystal display using only a driving voltage for each pixel as displayed at a front view and 60-degree side view and gamma curves of the liquid crystal display of the invention using two driving voltages for each pixel **232** as displayed at a front view and 60-degree side view are shown. An operational voltage of the display panel is 5.5V and an area ratio of the first sub-pixel **232a** and the second sub-pixel **232b** is 4:6. From FIG. 6A and FIG. 6B, it can be seen that by using two different driving voltages for a pixel **232**, the invention can effectively reduce the prior-art color deviation issue generated as a viewing angle varies.

When the liquid crystal display **200** of the invention is driven in a dot-inversion way, the panel can be driven in the following ways. As shown in FIG. 7 and FIG. 8, symbols + and - respectively denote positive and negative polarity of a pixel **232** and symbols \uparrow and \downarrow respectively denote pixels **232**

are driven in positive and negative directions. Different patterns of regions denote different display luminance. The transverse dotted-line, cross-dot and oblique dotted-line regions denote regions of normal luminance, the dense left-oblique-line, dense right-oblique-line and sparse lattice-like regions denote regions of lower luminance, while sparse left-oblique-line regions, sparse right-oblique-line and dense lattice-like regions denote regions of higher luminance.

As shown in FIG. 7, each of the (i, j)-th pixel **232**, (i+1, j)-th pixel **232**, (i, j+1)-th pixel **232** and (i+1, j+1)-th pixel **232** includes a red pixel R, green pixel G and blue pixel B arranged successively and in the red pixels R, green pixels G and blue pixels B, two adjacent pixels R, G or G, B or B, R or R, R or G, G or B, B have opposite driving polarity. When the gate signal S_i is stopped outputting, the first common-electrode voltage V_{com1} is increased from a low level to a high level. Thus, pixels with negative polarity (−) is driven in the negative direction (↓) while pixels with positive polarity (+) is driven in the positive direction (↑). When the gate signal $S_{(j+1)}$ is stopped outputting, the first common-electrode voltage V_{com1} is reduced from a high level to a low level. Thus, pixels with negative polarity (−) is driven in the positive direction (↑) while pixels with positive polarity (+) is driven in the negative direction (↓). Therefore, the adjacent pixels with the same color R, G or B of two adjacent rows of pixels **232** will have the same driving direction, but two adjacent pixels R, G or G, B or B, R in the same row of pixels **232** will have opposite driving direction.

A display result shows that the two adjacent pixels with the same color will have three situations of normal luminance, low luminance and higher luminance. For example, the green pixel G of the (i, j)-th pixel **232** has a region of normal luminance (a cross-dot region) and a region of higher luminance (sparse left-oblique-line region), the green pixel G of the (i, j+1)-th pixel **232** has a region of normal luminance (cross-dot region) and a region of lower luminance (sparse lattice-like region). This design (with three kinds of luminance) can reduce the above color-deviation issue.

FIG. 8 shows another panel driving method according to the preferred embodiment of the invention. The polarity of the i-th row of pixels **232** is periodically altered in the order of +, +, −, and the polarity of the (i+1)-th row of pixel **232** is periodically altered in the order of −, −, +. Analyzing according to the above principle, the pixels R, G, B of the i-th row of pixels **232** and the (i+1)-th pixel **232** are periodically driven in the directions of ↑, ↑, ↓, and the two adjacent pixels with the same color R, G, or B has the same luminance, which will not reduce resolution.

Of course, the invention is not limited to the above two panel driving methods, as long as the driving method can provide the pixel voltages V_{p1} and V_{p2} for driving liquid crystals according to the first common-electrode voltage V_{com1} or the second common-electrode voltage V_{com2} such that variations of the pixel voltages V_{p1} and V_{p2} are relevant to each other to achieve the purpose of eliminating the color-deviation issue, it will not depart from the scope of the invention.

As mentioned above, although the voltage coupling device **232c** of the liquid crystal display **200** in the invention is exemplified to be the capacitor C_c and coupled to the first common electrode $com1$ and the second common electrode $com2$, each pixel **232** of the invention can also use any other voltage coupling device **232c** such as a resistor and the voltage coupling device **232c** can also be coupled to the first pixel electrode PE1 and the second common electrode $com2$, or coupled to the first pixel electrode PE1 and the second pixel electrode PE2. As long as each pixel **232** has the voltage

coupling device **232c** coupled to the first sub-pixel **232a** and the second sub-pixel **232b** such that the pixel voltages V_{p1} and V_{p2} can be provided for driving liquid crystals according to the first voltage V_{e1} or the second voltage V_{e2} and variations of the pixel voltages V_{p1} and V_{p2} are relevant to each other to achieve the purpose of eliminating the color deviation issue, all these will not depart from the scope of the invention.

Besides, although the second common-electrode voltage V_{com2} and the pixel voltages V_{p1} and V_{p2} are exemplified to be adjusted by changing the first voltage V_{e1} , the liquid crystal display **200** of the invention can also adjust the pixel voltages V_{p1} and V_{p2} by changing the second voltage V_{e2} , or the first voltage V_{e1} and second voltage V_{e2} simultaneously. For example, the first voltage V_{e1} and second voltage V_{e2} can be adjusted in a swing-type waveform and the first voltage V_{e1} has a swing direction opposite to the second voltage V_{e2} . As long as the pixel **232** can have two different pixel voltages V_{p1} and V_{p2} through a voltage-coupling effect and variations of the pixel voltages V_{p1} and V_{p2} are relevant to each other, all the alternatives are not apart from the scope of the invention.

Moreover, except for the aligning type and manner as shown in FIG. 7 and FIG. 8, the first sub-pixel **232a** and the second sub-pixel **232b** of each pixel **232** can also be arranged in patterns of square, rectangle, triangle or zigzag. An area ratio of the first sub-pixel **232a** and the second sub-pixel **232b** is about $1/9 \sim 9$. Of course, each pixel **232** can also include three or more than three sub-pixels. The liquid crystal display **200** of the invention can also be a MVA-type or TN-type transmissive liquid crystal display or MVA-type or TN-type transmissive liquid crystal display.

In the liquid crystal display and driving method thereof disclosed by the above embodiment of the invention, two different pixel voltages are provided for each pixel by adjusting the voltage of a common electrode and variations of the two pixel voltages are relevant to each other due to a coupling effect of the voltage coupling device. Therefore, the prior-art color deviation issue can be solved to improve image quality of the liquid crystal display.

While the invention has been described by way of example and in terms of a preferred embodiment, it is to be understood that the invention is not limited thereto. On the contrary, it is intended to cover various modifications and similar arrangements and procedures, and the scope of the appended claims therefore should be accorded the broadest interpretation so as to encompass all such modifications and similar arrangements and procedures.

What is claimed is:

1. A liquid crystal display (LCD), comprising:

a gate driver, for outputting a plurality of gate signals successively;

a data driver, for providing a plurality of data signals; and

a pixel matrix, comprising a plurality of pixels coupled to the gate driver and the data driver, wherein each of the pixels receives a corresponding data signal according to a corresponding gate signal and each of the pixels comprises:

a first sub-pixel, comprising:

a first switch device, for outputting the corresponding data signal according to the corresponding gate signal;

a first pixel electrode, coupled to the first switch device for receiving the data signal;

a first electrode, for providing a first voltage;

a first common electrode; and

a first storage capacitor, formed between the first pixel electrode and the first common electrode;

9

- a second sub-pixel, comprising:
- a second switch device, for outputting the corresponding data signal according to the corresponding gate signal;
 - a second pixel electrode, coupled to the second switch device for receiving the data signal;
 - a second electrode, for providing a second voltage;
 - a second common electrode;
 - a second storage capacitor, formed between the second pixel electrode and the second common electrode; and
 - a third storage capacitor, formed between the second common electrode and the second electrode; and
 - a voltage coupling device, directly coupled to the first common electrode and the second common electrode such that the first common electrode is electrically related to the second common electrode.
2. The liquid crystal display according to claim 1, wherein the first switch device and the second switch device are thin film transistors (TFT).
 3. The liquid crystal display according to claim 1, wherein the first voltage has a swing waveform.
 4. The liquid crystal display according to claim 1, wherein the first electrodes and the second electrodes are both electrodes disposed on a lower substrate.

10

5. The liquid crystal display according to claim 1, wherein the gate driver outputs the gate signals via a plurality of gate lines, and the second electrode corresponding to each pixel is one of the gate lines close to the gate line coupled to the first switch device and the second switch device of the corresponding pixel.
6. The liquid crystal display according to claim 1, wherein the voltage coupling device is a capacitor.
7. The liquid crystal display according to claim 1, wherein the voltage coupling device is a resistor.
8. The liquid crystal display according to claim 1, wherein the first sub-pixels or the second sub-pixels have a pattern of square, rectangle, zigzag or triangle.
9. The liquid crystal display according to claim 1, wherein each of the pixels comprises exactly the first sub-pixel and the second sub-pixel, the first sub-pixel has an area not larger than the second sub-pixel and an area ratio of the first sub-pixel and the second sub-pixel is about $\frac{1}{9}$ ~1.
10. The liquid crystal display according to claim 1, is selected from a group of a multi-domain vertical alignment (MVA) or twisted nematic (TN) transmissive liquid crystal display or a MVA or TN transfective liquid crystal display.

* * * * *

专利名称(译)	液晶显示器及其驱动方法		
公开(公告)号	US7898607	公开(公告)日	2011-03-01
申请号	US12/795995	申请日	2010-06-08
[标]申请(专利权)人(译)	友达光电股份有限公司		
申请(专利权)人(译)	友达光电.		
当前申请(专利权)人(译)	友达光电.		
[标]发明人	SU JENN JIA TIEN MING FENG CHANG TING JUI CHEN PO LUN		
发明人	SU, JENN-JIA TIEN, MING-FENG CHANG, TING-JUI CHEN, PO-LUN		
IPC分类号	G02F1/1343		
CPC分类号	G09G3/3607 G09G3/3614 G09G3/3659 G09G2300/0876 G09G3/2003 G02F1/13306 G02F1/134309 G02F1/136213 G02F1/1368 G02F2001/134345 G09G3/3674 G09G3/3685 G09G2300/0452 G09G2300/ /0478 G09G2310/027 G09G2320/0276 G09G2320/0666 G09G2320/0673 G09G2320/068		
优先权	095133352 2006-09-08 TW		
其他公开文献	US20100245696A1		
外部链接	Espacenet USPTO		

摘要(译)

液晶显示器包括栅极驱动器，数据驱动器和像素矩阵。栅极驱动器用于连续输出多个栅极信号。数据驱动器用于提供多个数据信号。像素矩阵包括多个像素。每个像素包括第一子像素，第二子像素和电压耦合器件。电压耦合器件耦合在第一子像素和第二子像素之间，使得第一子像素和第二子像素的像素电压不同并且具有相关的变化。

