



US 20070075950A1

(19) **United States**

(12) **Patent Application Publication**
YAMADA et al.

(10) **Pub. No.: US 2007/0075950 A1**

(43) **Pub. Date: Apr. 5, 2007**

(54) **LIQUID CRYSTAL DISPLAY DEVICE**

Mar. 8, 2006 (JP)..... 2006-062860

(76) Inventors: **Yoshitaka YAMADA**, Fukaya-shi (JP);
Ryoichi Watanabe, Fukaya-shi (JP);
Masaki Kinoshita, Fukaya-shi (JP);
Yoshihiro Watanabe, Gyoda-shi (JP);
Sadayasu Fujibayashi, Fukaya-shi (JP);
Norihiro Yoshida, Fukaya-shi (JP)

Publication Classification

(51) **Int. Cl.**
G09G 3/36 (2006.01)
(52) **U.S. Cl.** **345/89**

Correspondence Address:

OBLON, SPIVAK, MCCLELLAND, MAIER & NEUSTADT, P.C.
1940 DUKE STREET
ALEXANDRIA, VA 22314 (US)

(57) **ABSTRACT**

A liquid crystal display device has a gradation display function of at least an n-number of gray levels and has a viewing angle characteristic of $M_i/M_j \leq 1.3$ in a case where a display luminance range in a normal direction to a display surface in a gradation range of predetermined gray levels i to j is L_i to L_j and a display luminance range in an oblique viewing-angle direction of 30° or more is M_i to M_j (where n, i and j are real numbers, and $n \geq i > j \geq 0$). The liquid crystal display device has a display mode in which a display image is displayed with a display luminance range of the display image being limited to L_i to L_j .

(21) Appl. No.: **11/468,659**

(22) Filed: **Aug. 30, 2006**

(30) **Foreign Application Priority Data**

Sep. 6, 2005 (JP)..... 2005-257954

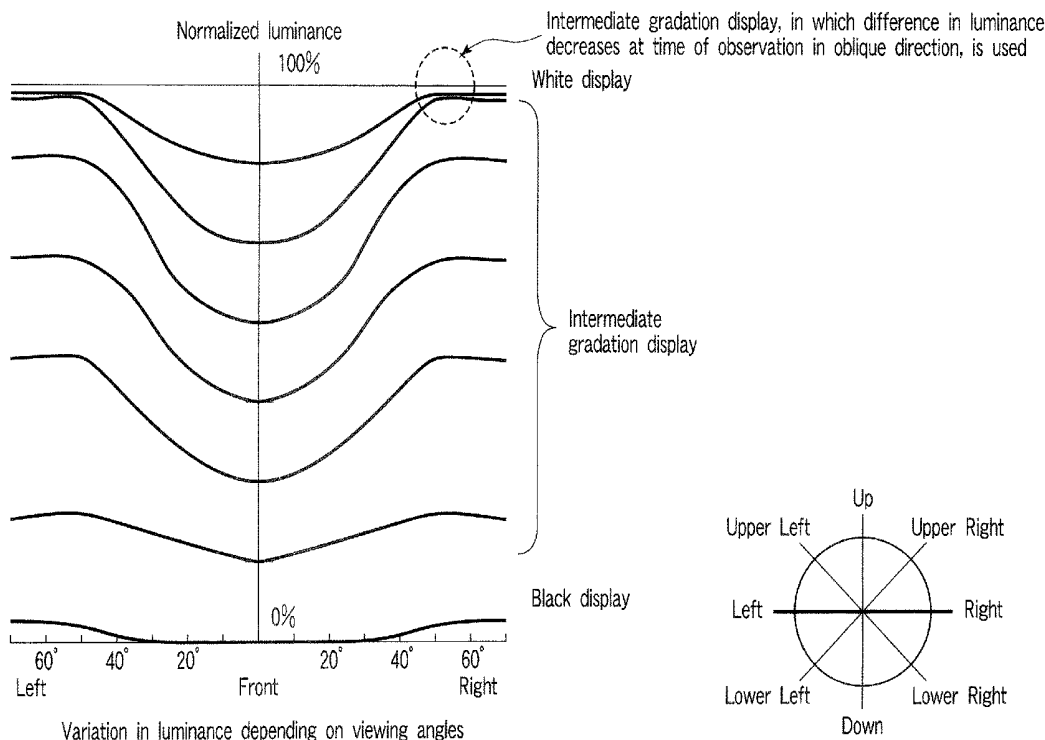

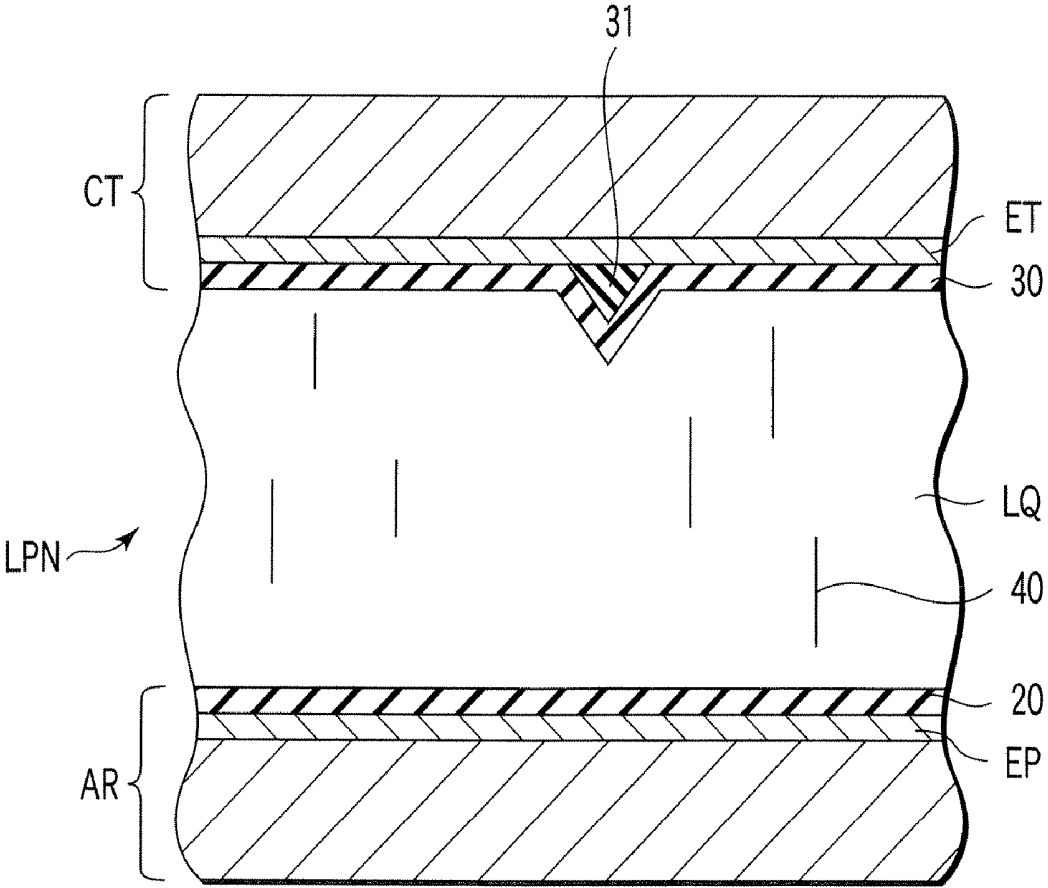

FIG. 2

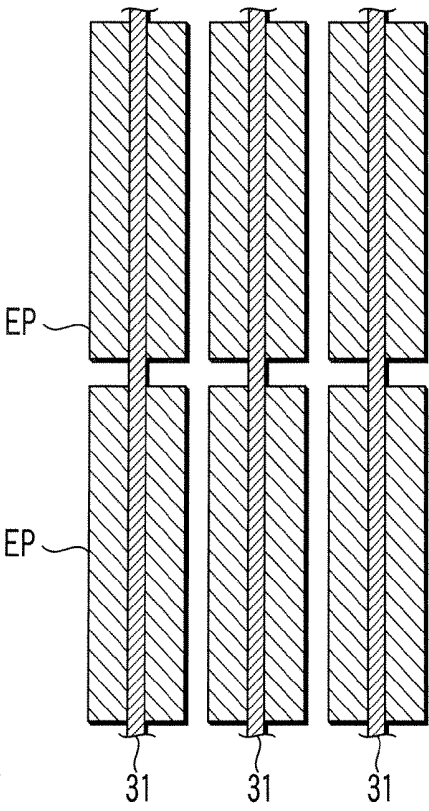

FIG. 3A

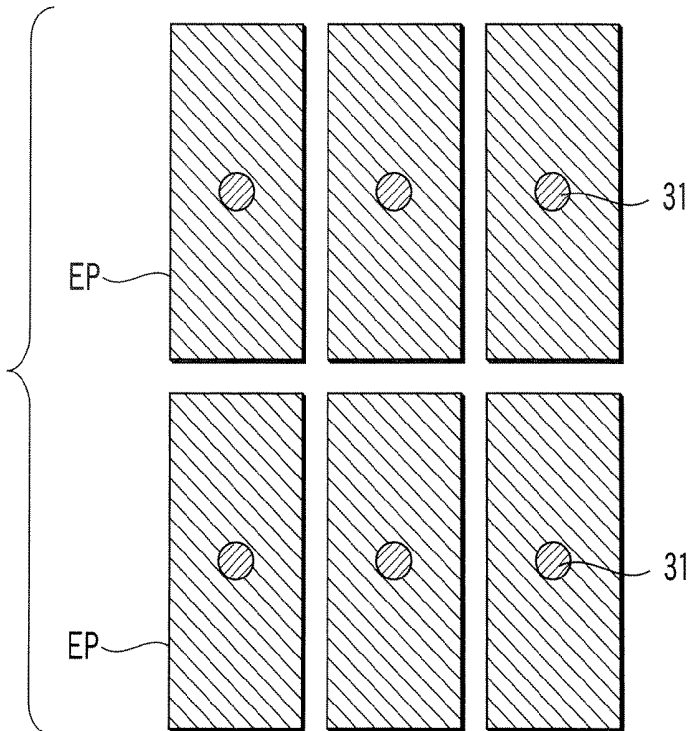

FIG. 3B

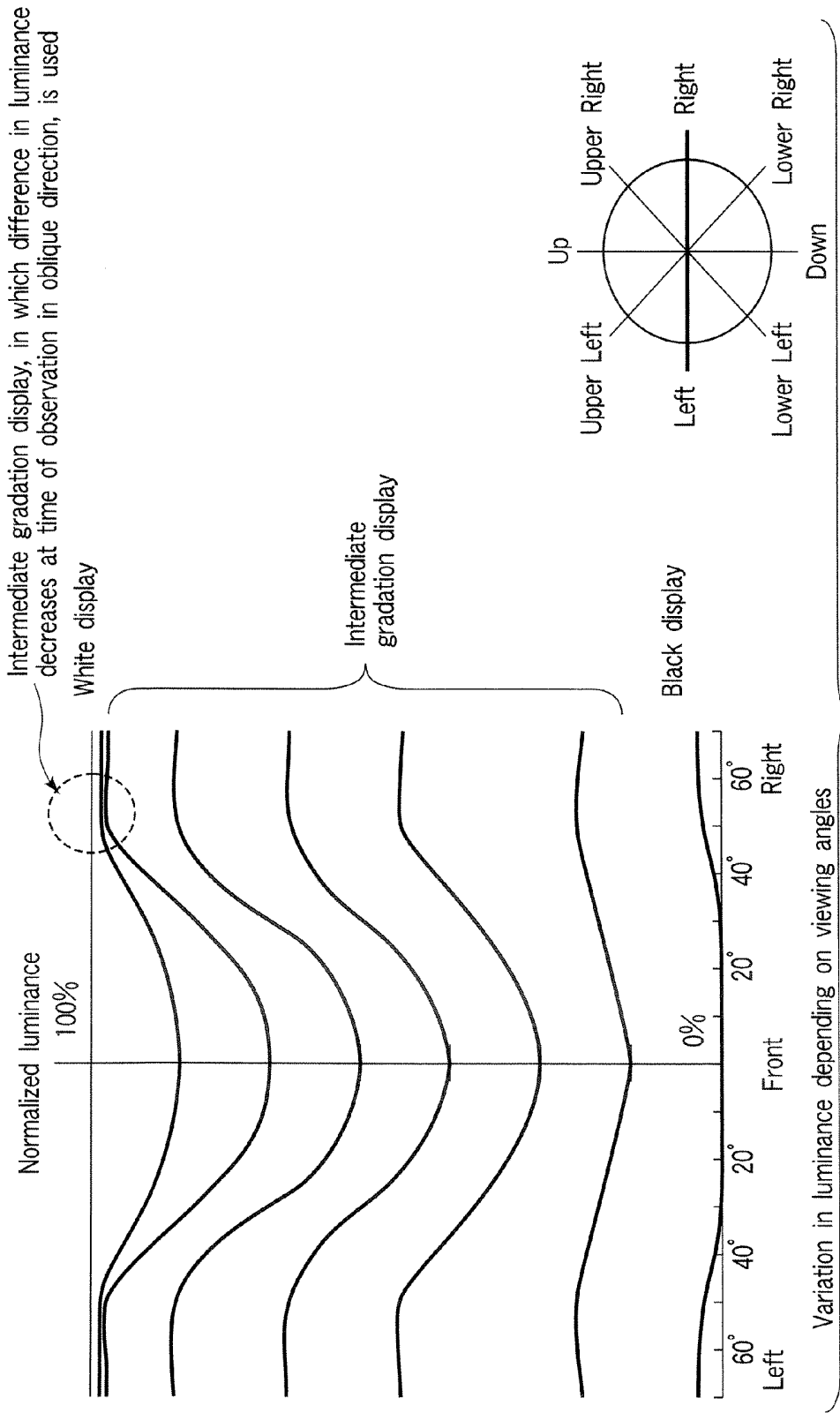
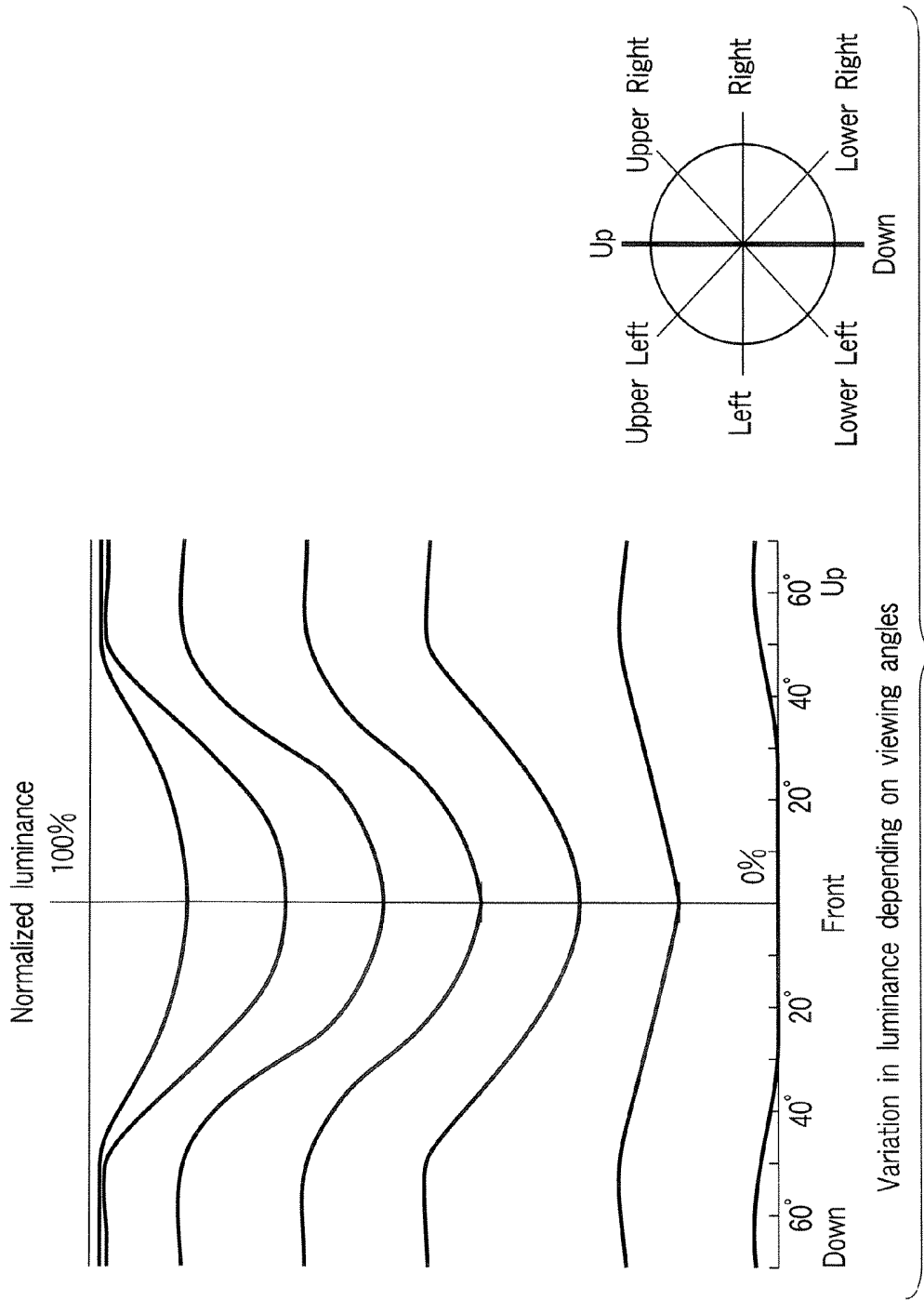

FIG. 4A



Variation in luminance depending on viewing angles

FIG. 4B

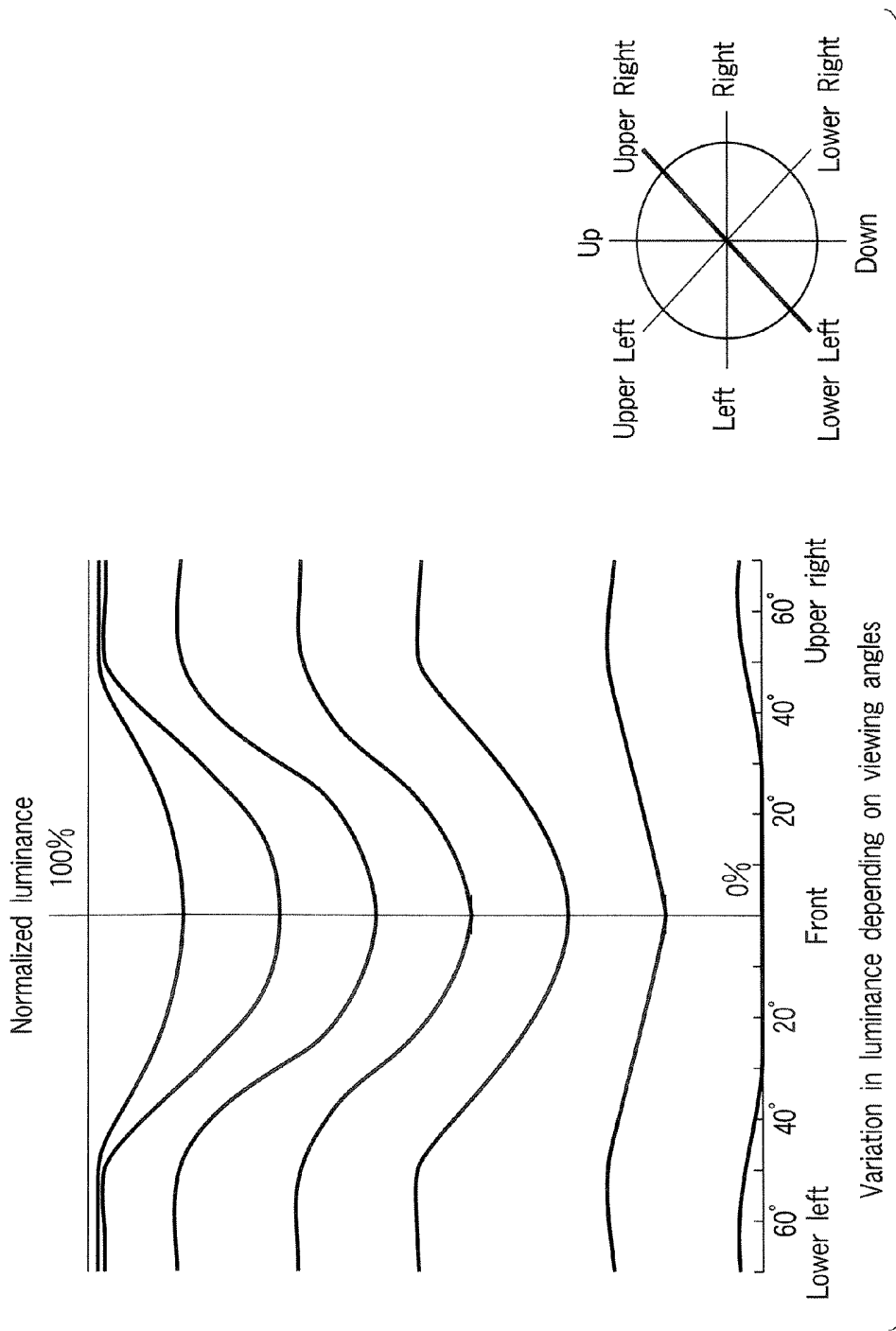

FIG. 4C

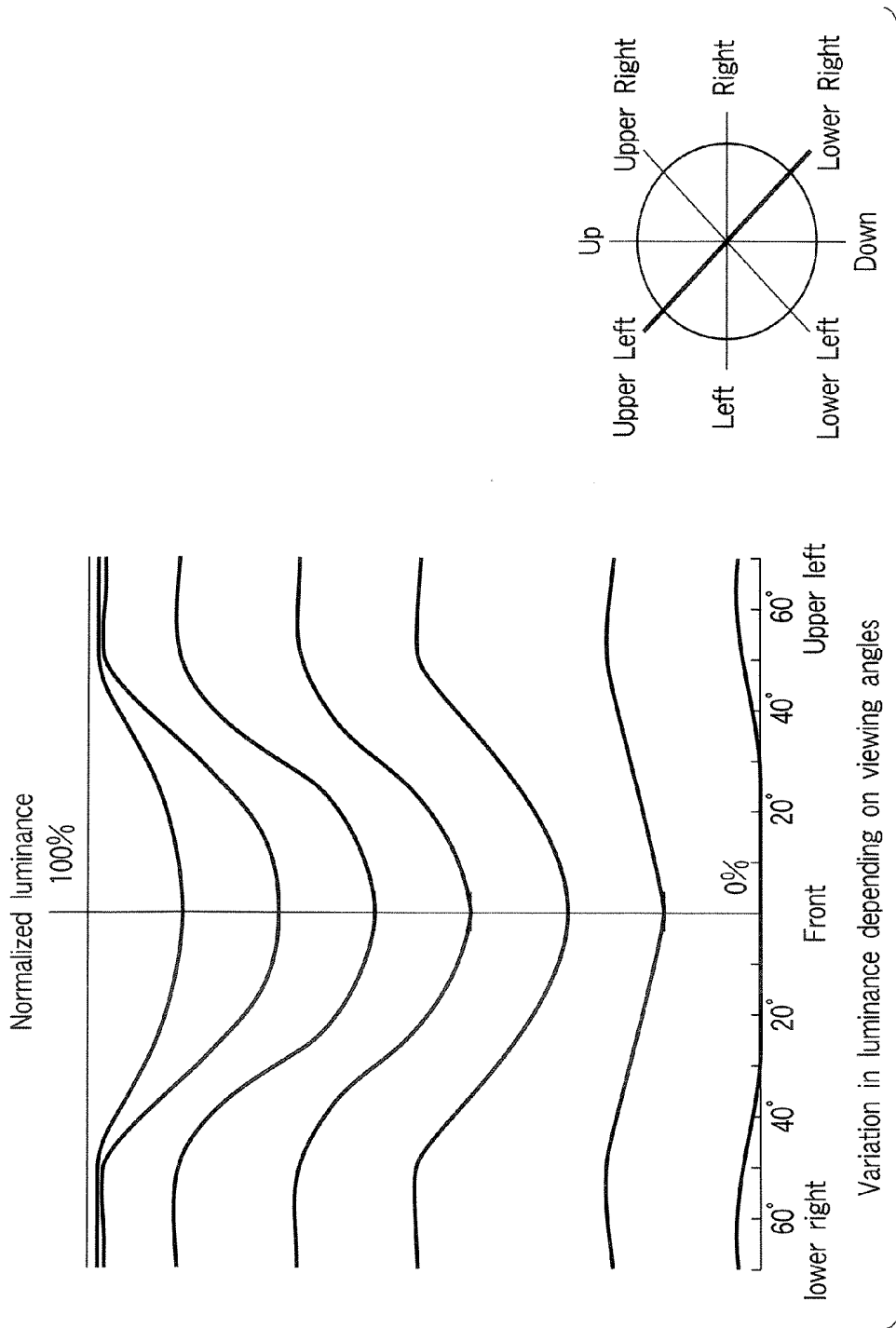

FIG. 4D

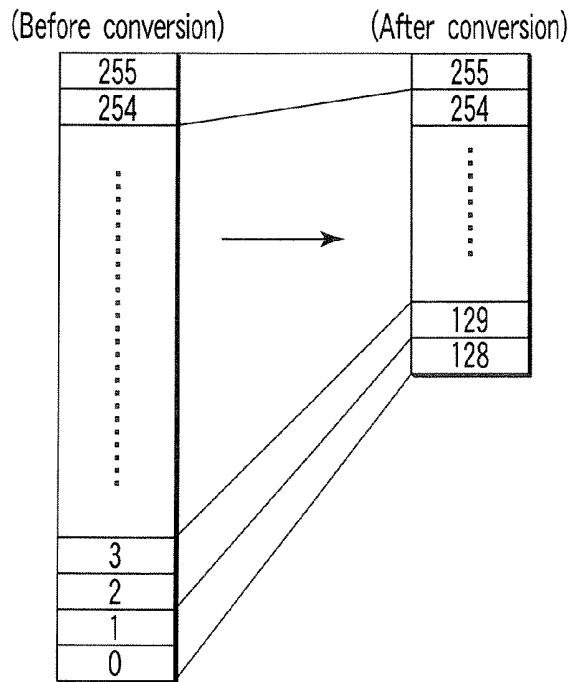

FIG. 5

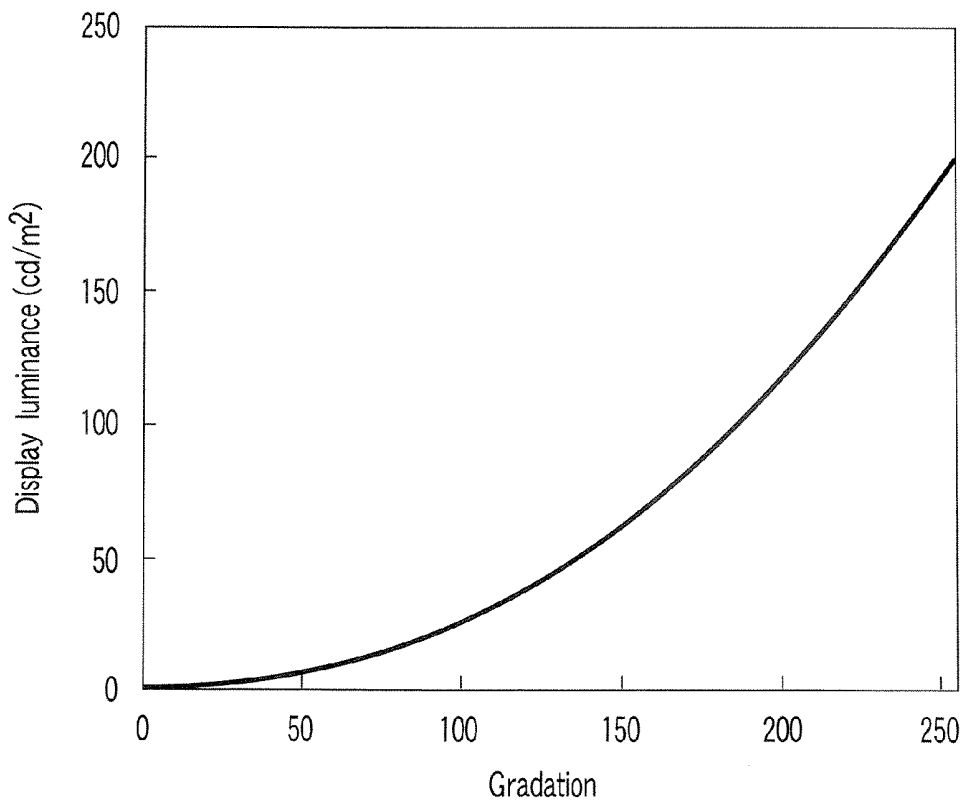

FIG. 8

FIG. 6

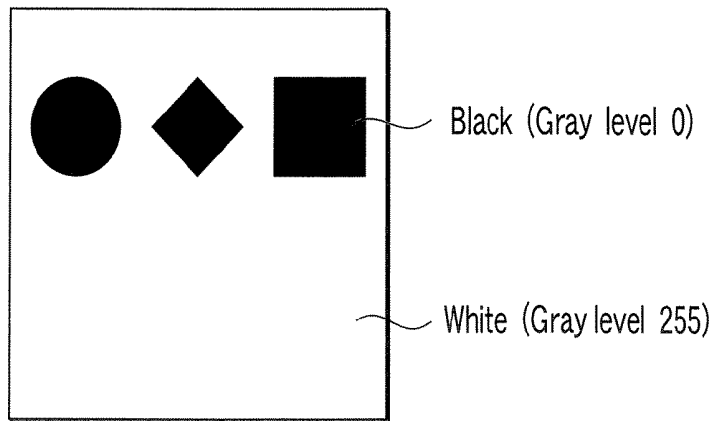

FIG. 7A

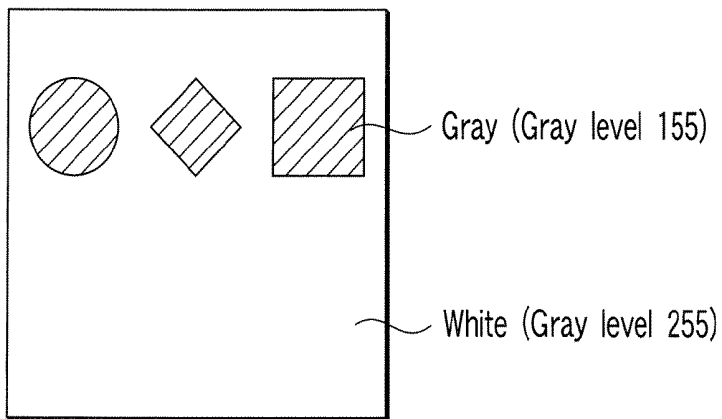

FIG. 7B

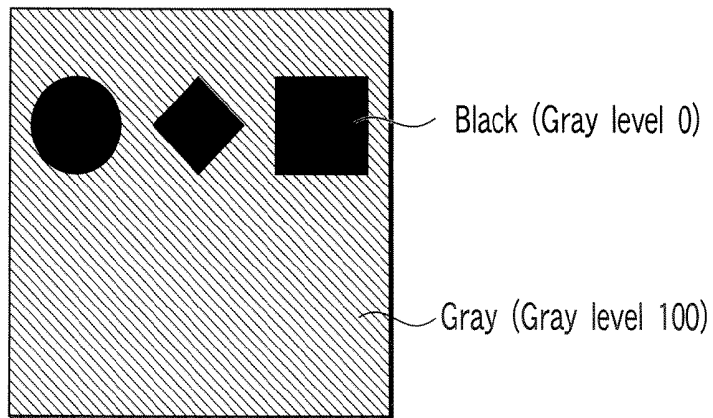
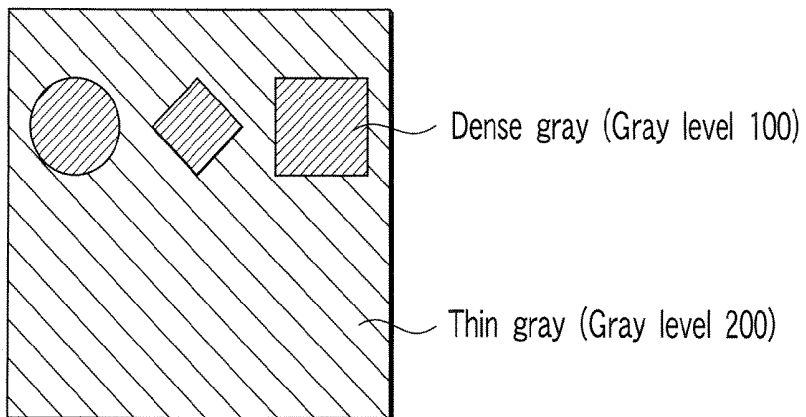

FIG. 7C



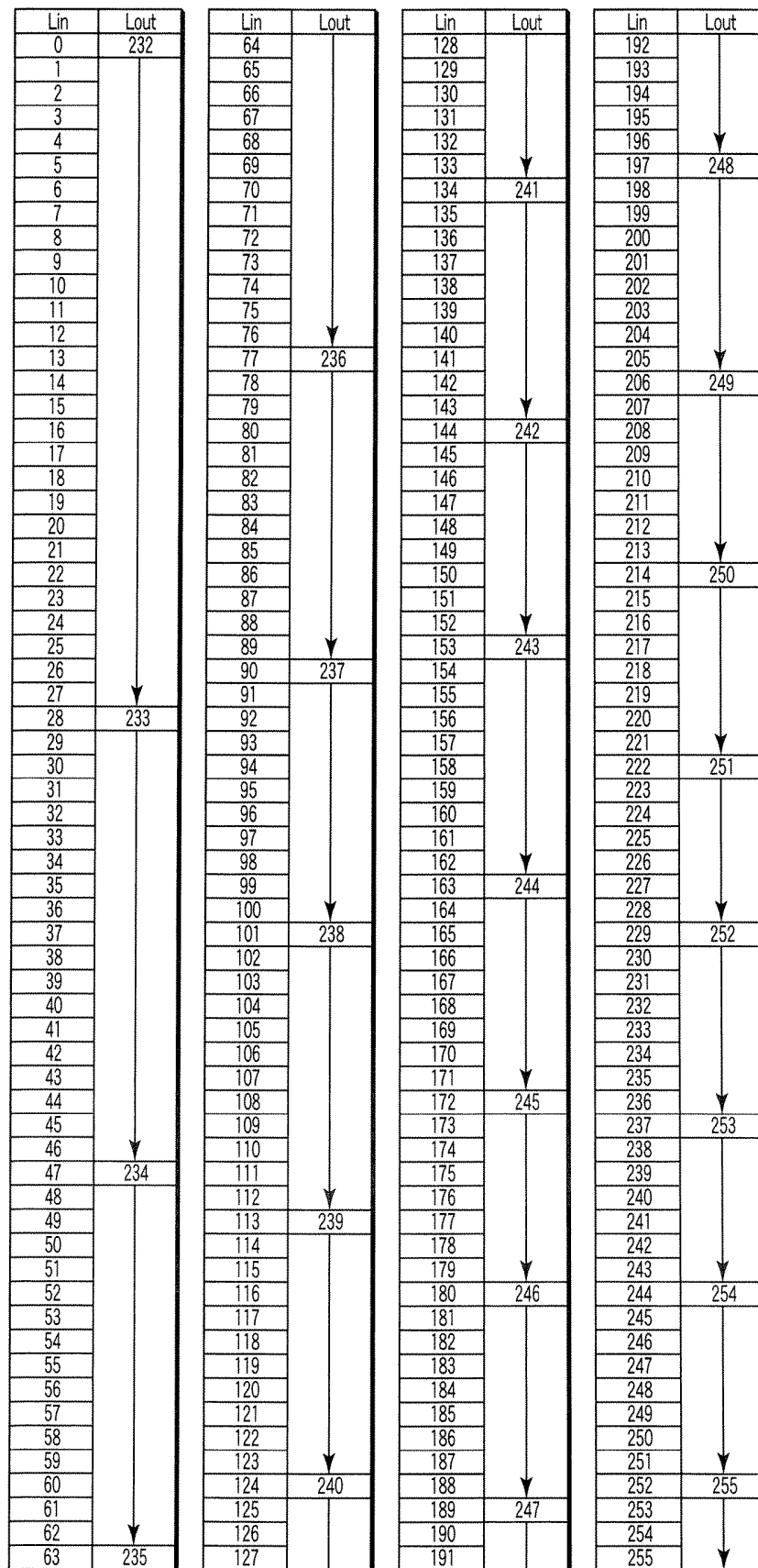

FIG. 9

Lin	Lout			Lin	Lout		
	R	G	B		R	G	B
0	40	42	35	32	48	49	45
1	40	42	35	33	49	50	45
2	40	42	35	34	49	50	46
3	40	42	35	35	49	50	46
4	40	42	35	36	50	51	47
5	40	42	35	37	50	51	47
6	40	42	35	38	51	52	48
7	41	42	36	39	51	52	48
8	41	43	36	40	51	52	49
9	41	43	36	41	52	53	50
10	41	43	36	42	52	53	50
11	41	43	37	43	53	54	51
12	42	43	37	44	53	54	51
13	42	44	37	45	54	55	52
14	42	44	38	46	54	55	52
15	42	44	38	47	55	55	53
16	43	44	38	48	55	56	54
17	43	45	39	49	56	56	54
18	43	45	39	50	56	57	55
19	44	45	39	51	57	57	55
20	44	45	40	52	57	58	56
21	44	46	40	53	58	58	57
22	45	46	41	54	58	59	57
23	45	46	41	55	59	59	58
24	45	47	41	56	59	60	58
25	46	47	42	57	60	60	59
26	46	47	42	58	60	61	60
27	46	48	43	59	61	61	60
28	47	48	43	60	61	61	61
29	47	48	44	61	62	62	62
30	47	49	44	62	62	62	62
31	48	49	44	63	63	63	63

FIG. 10

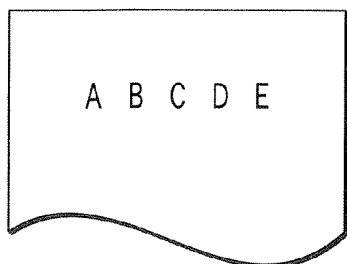

FIG. 11A

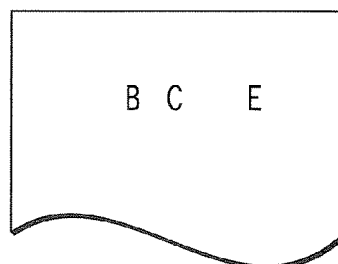

FIG. 11B

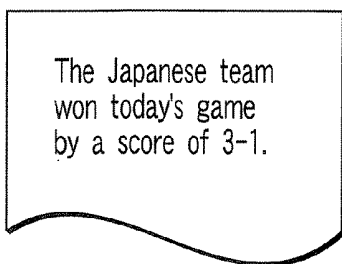

FIG. 12A

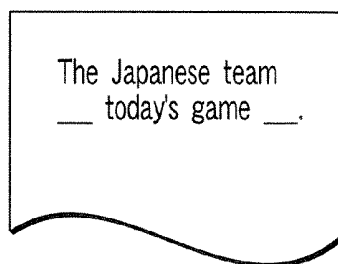

FIG. 12B

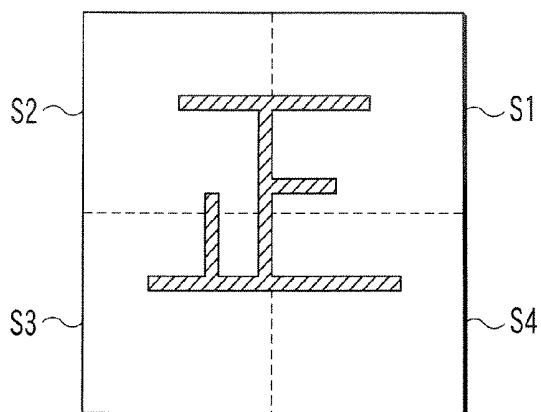

FIG. 13

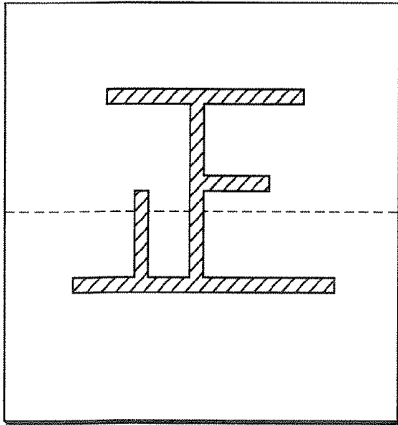

FIG. 14A

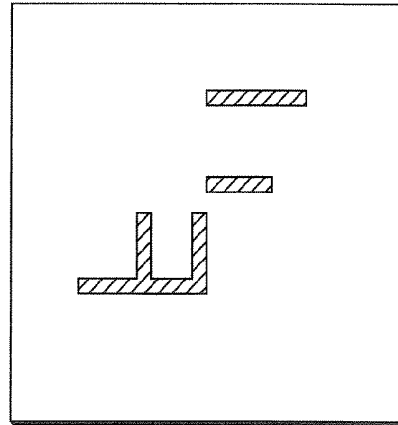

FIG. 14B

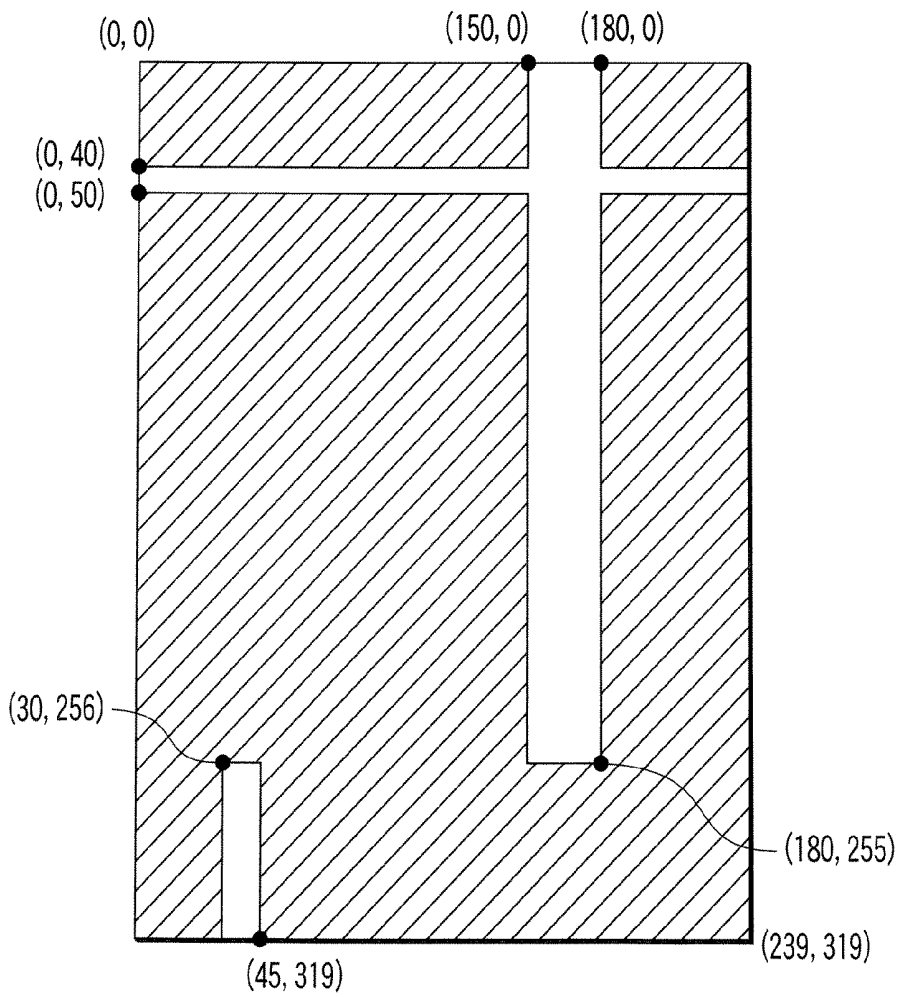

FIG. 15

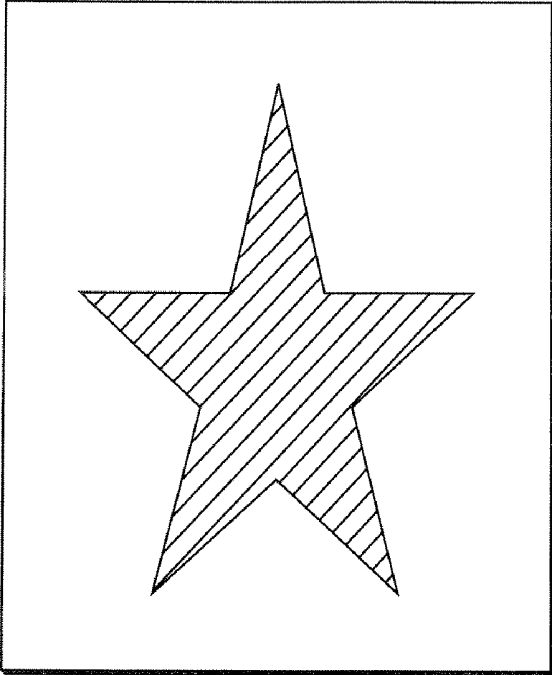

FIG. 16A

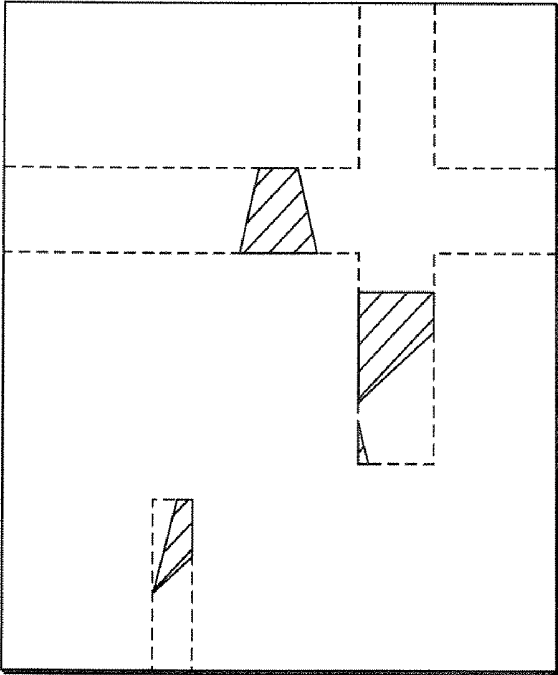

FIG. 16B

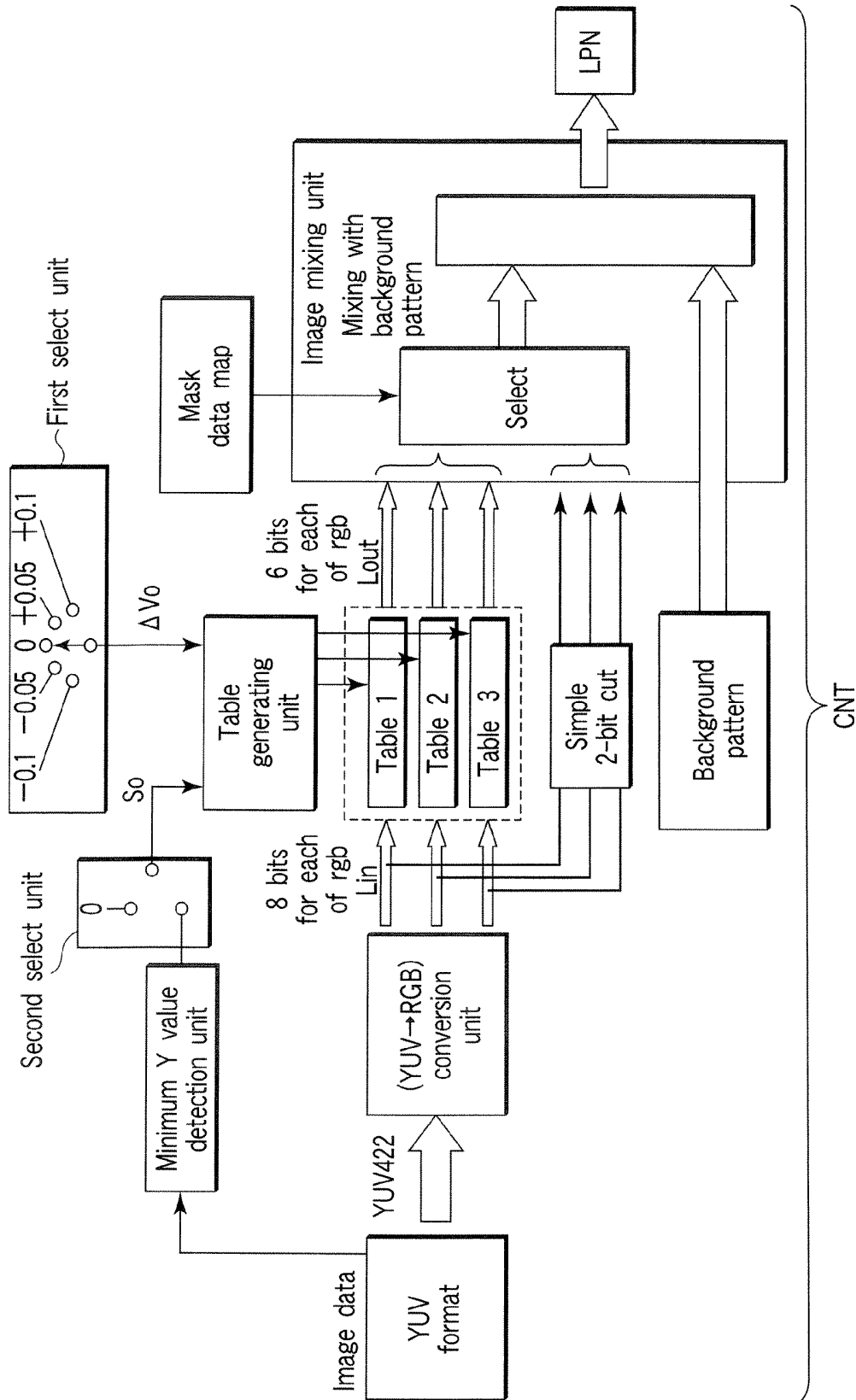

FIG. 17

Table 1

Lin	Lout	Lin	Lout	Lin	Lout	Lin	Lout
0	40	64	43	128	48	192	55
1	40	65	43	129	48	193	55
2	40	66	43	130	48	194	55
3	40	67	43	131	48	195	55
4	40	68	43	132	48	196	55
5	40	69	43	133	48	197	56
6	40	70	43	134	49	198	56
7	40	71	43	135	49	199	56
8	40	72	43	136	49	200	56
9	40	73	43	137	49	201	56
10	40	74	43	138	49	202	56
11	40	75	43	139	49	203	56
12	40	76	43	140	49	204	56
13	40	77	44	141	49	205	56
14	40	78	44	142	49	206	57
15	40	79	44	143	49	207	57
16	40	80	44	144	50	208	57
17	40	81	44	145	50	209	57
18	40	82	44	146	50	210	57
19	40	83	44	147	50	211	57
20	40	84	44	148	50	212	57
21	40	85	44	149	50	213	57
22	40	86	44	150	50	214	58
23	40	87	44	151	50	215	58
24	40	88	44	152	50	216	58
25	40	89	44	153	51	217	58
26	40	90	45	154	51	218	58
27	40	91	45	155	51	219	58
28	41	92	45	156	51	220	58
29	41	93	45	157	51	221	58
30	41	94	45	158	51	222	59
31	41	95	45	159	51	223	59
32	41	96	45	160	51	224	59
33	41	97	45	161	51	225	59
34	41	98	45	162	51	226	59
35	41	99	45	163	52	227	59
36	41	100	45	164	52	228	59
37	41	101	46	165	52	229	60
38	41	102	46	166	52	230	60
39	41	103	46	167	52	231	60
40	41	104	46	168	52	232	60
41	41	105	46	169	52	233	60
42	41	106	46	170	52	234	60
43	41	107	46	171	52	235	60
44	41	108	46	172	53	236	60
45	41	109	46	173	53	237	61
46	41	110	46	174	53	238	61
47	42	111	46	175	53	239	61
48	42	112	46	176	53	240	61
49	42	113	47	177	53	241	61
50	42	114	47	178	53	242	61
51	42	115	47	179	53	243	61
52	42	116	47	180	54	244	62
53	42	117	47	181	54	245	62
54	42	118	47	182	54	246	62
55	42	119	47	183	54	247	62
56	42	120	47	184	54	248	62
57	42	121	47	185	54	249	62
58	42	122	47	186	54	250	62
59	42	123	47	187	54	251	62
60	42	124	48	188	54	252	63
61	42	125	48	189	55	253	63
62	42	126	48	190	55	254	63
63	43	127	48	191	55	255	63

FIG. 18A

Table 2

Lin	Lout	Lin	Lout	Lin	Lout	Lin	Lout
0	42	64	44	128	49	192	56
1	42	65	44	129	49	193	56
2	42	66	44	130	49	194	56
3	42	67	44	131	49	195	56
4	42	68	45	132	50	196	56
5	42	69	45	133	50	197	56
6	42	70	45	134	50	198	56
7	42	71	45	135	50	199	56
8	42	72	45	136	50	200	56
9	42	73	45	137	50	201	57
10	42	74	45	138	50	202	57
11	42	75	45	139	50	203	57
12	42	76	45	140	50	204	57
13	42	77	45	141	50	205	57
14	42	78	45	142	50	206	57
15	42	79	45	143	51	207	57
16	42	80	45	144	51	208	57
17	42	81	45	145	51	209	57
18	42	82	45	146	51	210	58
19	42	83	46	147	51	211	58
20	42	84	46	148	51	212	58
21	42	85	46	149	51	213	58
22	42	86	46	150	51	214	58
23	42	87	46	151	51	215	58
24	42	88	46	152	51	216	58
25	42	89	46	153	52	217	58
26	42	90	46	154	52	218	59
27	42	91	46	155	52	219	59
28	42	92	46	156	52	220	59
29	42	93	46	157	52	221	59
30	42	94	46	158	52	222	59
31	42	95	46	159	52	223	59
32	43	96	47	160	52	224	59
33	43	97	47	161	52	225	59
34	43	98	47	162	52	226	59
35	43	99	47	163	53	227	60
36	43	100	47	164	53	228	60
37	43	101	47	165	53	229	60
38	43	102	47	166	53	230	60
39	43	103	47	167	53	231	60
40	43	104	47	168	53	232	60
41	43	105	47	169	53	233	60
42	43	106	47	170	53	234	60
43	43	107	47	171	53	235	61
44	43	108	47	172	53	236	61
45	43	109	48	173	54	237	61
46	43	110	48	174	54	238	61
47	43	111	48	175	54	239	61
48	43	112	48	176	54	240	61
49	43	113	48	177	54	241	61
50	43	114	48	178	54	242	61
51	43	115	48	179	54	243	62
52	44	116	48	180	54	244	62
53	44	117	48	181	54	245	62
54	44	118	48	182	54	246	62
55	44	119	48	183	55	247	62
56	44	120	48	184	55	248	62
57	44	121	49	185	55	249	62
58	44	122	49	186	55	250	62
59	44	123	49	187	55	251	62
60	44	124	49	188	55	252	63
61	44	125	49	189	55	253	63
62	44	126	49	190	55	254	63
63	44	127	49	191	55	255	63

FIG. 18B

Table 3

Lin	Lout	Lin	Lout	Lin	Lout	Lin	Lout
0	35	64	38	128	45	192	53
1	35	65	38	129	45	193	53
2	35	66	38	130	45	194	53
3	35	67	38	131	45	195	54
4	35	68	39	132	45	196	54
5	35	69	39	133	45	197	54
6	35	70	39	134	45	198	54
7	35	71	39	135	46	199	54
8	35	72	39	136	46	200	54
9	35	73	39	137	46	201	54
10	35	74	39	138	46	202	55
11	35	75	39	139	46	203	55
12	35	76	39	140	46	204	55
13	35	77	39	141	46	205	55
14	35	78	39	142	46	206	55
15	35	79	40	143	47	207	55
16	35	80	40	144	47	208	56
17	35	81	40	145	47	209	56
18	35	82	40	146	47	210	56
19	35	83	40	147	47	211	56
20	35	84	40	148	47	212	56
21	35	85	40	149	47	213	56
22	35	86	40	150	47	214	56
23	35	87	40	151	48	215	57
24	35	88	40	152	48	216	57
25	36	89	40	153	48	217	57
26	36	90	41	154	48	218	57
27	36	91	41	155	48	219	57
28	36	92	41	156	48	220	57
29	36	93	41	157	48	221	58
30	36	94	41	158	48	222	58
31	36	95	41	159	49	223	58
32	36	96	41	160	49	224	58
33	36	97	41	161	49	225	58
34	36	98	41	162	49	226	58
35	36	99	42	163	49	227	58
36	36	100	42	164	49	228	59
37	36	101	42	165	49	229	59
38	36	102	42	166	50	230	59
39	36	103	42	167	50	231	59
40	36	104	42	168	50	232	59
41	36	105	42	169	50	233	59
42	37	106	42	170	50	234	60
43	37	107	42	171	50	235	60
44	37	108	42	172	50	236	60
45	37	109	43	173	50	237	60
46	37	110	43	174	51	238	60
47	37	111	43	175	51	239	60
48	37	112	43	176	51	240	61
49	37	113	43	177	51	241	61
50	37	114	43	178	51	242	61
51	37	115	43	179	51	243	61
52	37	116	43	180	51	244	61
53	37	117	43	181	52	245	61
54	37	118	44	182	52	246	62
55	37	119	44	183	52	247	62
56	38	120	44	184	52	248	62
57	38	121	44	185	52	249	62
58	38	122	44	186	52	250	62
59	38	123	44	187	52	251	62
60	38	124	44	188	53	252	63
61	38	125	44	189	53	253	63
62	38	126	44	190	53	254	63
63	38	127	45	191	53	255	63

FIG. 18C

FIG. 19

$$S_{out} = \begin{cases} V_o & S_o < S_{in} \\ \frac{S_{in}^\beta + V_f}{1 + V_f} & 1 > S_o^\beta \end{cases} \quad \text{————— (Formula 1)}$$

Where

$$V_f = - \frac{S_o^\beta - V_o}{1 - V_o}$$

S_{in} : Normalized input gradation
 β : Gradient coefficient
 V_o : Offset
 S_o : Normalized input reference gradation

	R	G	B
β	1.5	1.5	1.5
V_o	$0.63 + \Delta V_o$	$0.66 + \Delta V_o$	$0.55 + \Delta V_o$
S_o	0	0	0

FIG. 20

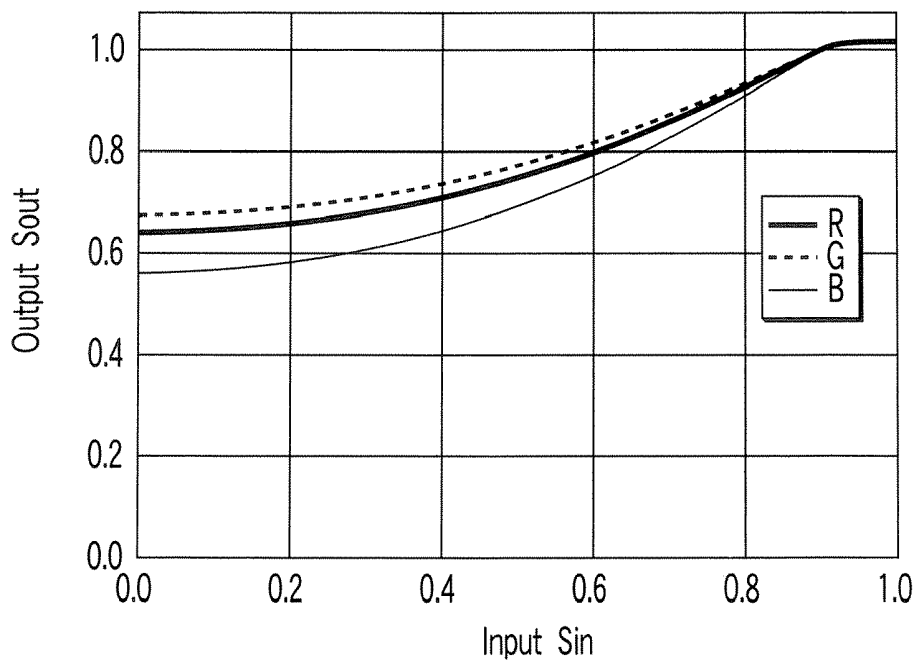

FIG. 21

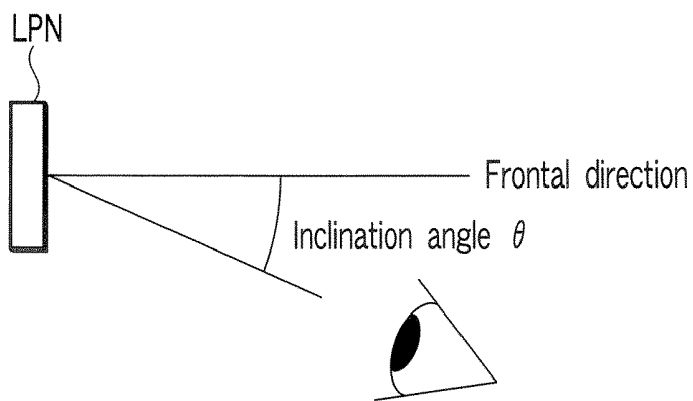

FIG. 22

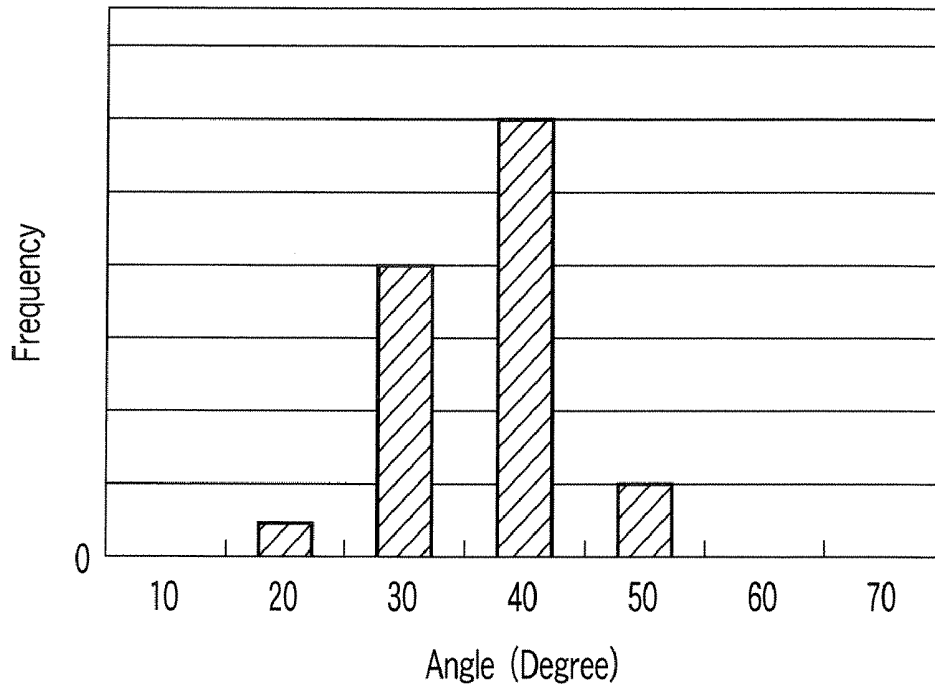

FIG. 23

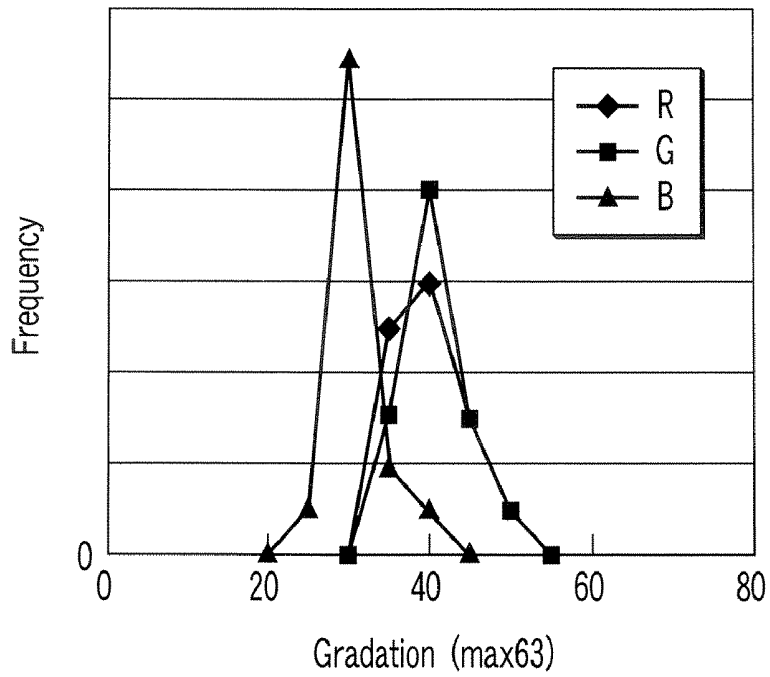

FIG. 24

LIQUID CRYSTAL DISPLAY DEVICE

CROSS-REFERENCE TO RELATED APPLICATIONS

[0001] This application is based upon and claims the benefit of priority from prior Japanese Patent Applications No. 2005-257954, filed Sep. 6, 2005; and No. 2006-062860, filed Mar. 8, 2006, the entire contents of both of which are incorporated herein by reference.

BACKGROUND OF THE INVENTION

[0002] 1. Field of the Invention

[0003] The present invention relates generally to a liquid crystal display device, and more particularly to a liquid crystal display device which is configured to be capable of realizing both a wide viewing angle and a narrow viewing angle.

[0004] 2. Description of the Related Art

[0005] In recent years, mobile phones, which can display mail and images, have widely been used. In using such mobile phones, there have been increasing needs for preventing a displayed image from being peeped at by persons around the user.

[0006] To satisfy such needs, Jpn. Pat. Appln. KOKAI Publication No. 2004-062094 (Patent Document 1), for instance, proposes a structure wherein a liquid crystal plate for varying a viewing angle is superposed on the front surface of a liquid crystal display (LCD). According to the structure of Patent Document 1, however, it is difficult to restrict omnidirectional viewing angles, because of the effect of viewing angle characteristics of the liquid crystal plate for varying the viewing angle. Moreover, the addition of the liquid crystal plate for varying the viewing angle leads to demerits such as an increase in cost, thickness, weight and power consumption.

[0007] Jpn. Pat. Appln. KOKAI Publication No. 2003-295160 (Patent Document 2) and Jpn. Pat. Appln. KOKAI Publication No. 2004-318112 (Patent Document 3) propose structures wherein a lookup table is provided for adjusting a distortion of a gradation curve on a display screen due to viewing angles, and display data is generated on the basis of a result of the reference to the lookup table. According to Patent Document 2 and Patent Document 3, a screen image is displayed with a wide viewing angle range (a wide viewing angle) by making such adjustment as to decrease a distortion of the gradation curve due to viewing angles, and a screen image is displayed with a narrow viewing angle range (a narrow viewing angle) by making such adjustment as to increase a distortion of the gradation curve due to viewing angles.

BRIEF SUMMARY OF THE INVENTION

[0008] The present invention has been made in consideration of the above-described problems, and the object of the invention is to provide a liquid crystal display device which is capable of controlling viewing angles without increasing the cost of the display device or increasing the thickness, weight and power consumption of the entire display device.

[0009] According to an aspect of the invention, there is provided a liquid crystal display device having a gradation

display function of at least an n-number of gray levels and having a viewing angle characteristic of $M_i/M_j \leq 1.3$ in a case where a display luminance range in a normal direction to a display surface in a gradation range of a gray level i to a gray level j is L_i to L_j and a display luminance range in an oblique viewing-angle direction of 30° or more is M_i to M_j (where n, i and j are real numbers, and $n \geq i > j \geq 0$), wherein the liquid crystal display device has a display mode in which a display image is displayed with a display luminance range of the display image being limited to L_i to L_j .

[0010] The present invention can provide a liquid crystal display device which is capable of controlling viewing angles without increasing the cost of the display device or increasing the thickness, weight and power consumption of the entire display device.

[0011] Additional objects and advantages of the invention will be set forth in the description which follows, and in part will be obvious from the description, or may be learned by practice of the invention. The objects and advantages of the invention may be realized and obtained by means of the instrumentalities and combinations particularly pointed out hereinafter.

BRIEF DESCRIPTION OF THE SEVERAL VIEWS OF THE DRAWING

[0012] The accompanying drawings, which are incorporated in and constitute a part of the specification, illustrate embodiments of the invention, and together with the general description given above and the detailed description of the embodiments given below, serve to explain the principles of the invention.

[0013] FIG. 1 schematically shows the structure of a liquid crystal display device according to an embodiment of the present invention;

[0014] FIG. 2 schematically shows a cross-sectional structure of the liquid crystal display device shown in FIG. 1;

[0015] FIG. 3A schematically shows a rib structure, which is applied as a multi-domain structure in the liquid crystal display device shown in FIG. 1;

[0016] FIG. 3B schematically shows columnar or conical protrusions which are applied as a multi-domain structure in the liquid crystal display device shown in FIG. 1;

[0017] FIG. 4A shows measurement results of relative display luminance at respective gray levels in a right-and-left direction on a display surface of the liquid crystal display device shown in FIG. 1;

[0018] FIG. 4B shows measurement results of relative display luminance at respective gray levels in an up-and-down direction on the display surface of the liquid crystal display device shown in FIG. 1;

[0019] FIG. 4C shows measurement results of relative display luminance at respective gray levels in an upper-right-and-lower-left direction on the display surface of the liquid crystal display device shown in FIG. 1;

[0020] FIG. 4D shows measurement results of relative display luminance at respective gray levels in an upper-left-and-lower-right direction on the display surface of the liquid crystal display device shown in FIG. 1;

[0021] FIG. 5 is a view for explaining an example of conversion of image data in the liquid crystal display device shown in FIG. 1;

[0022] FIG. 6 is a view for explaining another example of conversion of image data in the liquid crystal display device shown in FIG. 1, and is a view for explaining display content based on original image data;

[0023] FIG. 7A is a view for explaining display content based on image data which is obtained after the original image data shown in FIG. 6 is converted;

[0024] FIG. 7B is a view for explaining display content based on image data which is obtained after the original image data shown in FIG. 6 is converted;

[0025] FIG. 7C is a view for explaining display content based on image data which is obtained after the original image data shown in FIG. 6 is converted;

[0026] FIG. 8 is a graph showing an example of the relationship between gradation display and display luminance;

[0027] FIG. 9 is a view for explaining an example of gradation conversion of image data in Embodiment 1;

[0028] FIG. 10 is a view for explaining an example of gradation conversion of image data in Embodiment 2;

[0029] FIG. 11A is a view for explaining an example of conversion in Example 1 of Embodiment 3, and shows an example of an image which is visually recognizable when a liquid crystal display panel is observed in a frontal direction;

[0030] FIG. 11B is a view for explaining an example of conversion in Example 1 of Embodiment 3, and shows an example of an image which is visually recognizable when the liquid crystal display panel is observed in an oblique direction;

[0031] FIG. 12A is a view for explaining an example of conversion in Example 1 of Embodiment 3, and shows an example of an image which is visually recognizable when a liquid crystal display panel is observed in a frontal direction;

[0032] FIG. 12B is a view for explaining an example of conversion in Example 1 of Embodiment 3, and shows an example of an image which is visually recognizable when the liquid crystal display panel is observed in an oblique direction;

[0033] FIG. 13 is a view for explaining an example of conversion in Example 2 of Embodiment 3;

[0034] FIG. 14A is a view for explaining an example of conversion in Example 2 of Embodiment 3, and shows an example of an image which is visually recognizable when a liquid crystal display panel is observed in a frontal direction;

[0035] FIG. 14B is a view for explaining an example of conversion in Example 2 of Embodiment 3, and shows an example of an image which is visually recognizable when the liquid crystal display panel is observed in an oblique direction;

[0036] FIG. 15 is a view for explaining an example of conversion in Example 3 of Embodiment 3;

[0037] FIG. 16A is a view for explaining an example of conversion in Example 3 of Embodiment 3, and shows an

example of an image which is visually recognizable when a liquid crystal display panel is observed in a frontal direction;

[0038] FIG. 16B is a view for explaining an example of conversion in Example 3 of Embodiment 3, and shows an example of an image which is visually recognizable when the liquid crystal display panel is observed in an oblique direction;

[0039] FIG. 17 is a view for describing an example of the structure of a controller which is applicable to the embodiments of the invention;

[0040] FIG. 18A shows an example of table 1 shown in FIG. 17;

[0041] FIG. 18B shows an example of table 2 shown in FIG. 17;

[0042] FIG. 18C shows an example of table 3 shown in FIG. 17;

[0043] FIG. 19 shows a relational formula which is applicable to the generation of a table in a table generating unit shown in FIG. 17;

[0044] FIG. 20 shows an example of parameters which are set in the relational formula shown in FIG. 19;

[0045] FIG. 21 shows an example of conversion characteristics which are based on the relational formula shown in FIG. 19;

[0046] FIG. 22 is a view for explaining a verification method which is applied when an optimal gradation range in a narrow viewing angle mode is to be determined;

[0047] FIG. 23 shows a distribution of angles at which a display screen is peeped at by a stranger when the user and the stranger are side by side; and

[0048] FIG. 24 shows a distribution of gray levels at which an image cannot be recognized when the image is observed at 40° in an oblique direction.

DETAILED DESCRIPTION OF THE INVENTION

[0049] A liquid crystal display device according to an embodiment of the present invention, in particular, an active-matrix liquid crystal display device, will now be described with reference to the accompanying drawings. The liquid crystal display device to be described here may be of any type, for example, a transmissive liquid crystal display device which displays an image by making use of backlight, a reflective liquid crystal display device which displays an image by making use of ambient light, or a transreflective liquid crystal display device having a reflective part and a transmissive part.

[0050] As is shown in FIG. 1 and FIG. 2, the liquid crystal display device includes a liquid crystal display panel LPN. The liquid crystal display panel LPN is configured to include an array substrate (first substrate) AR, a counter-substrate (second substrate) CT which is disposed to be opposed to the array substrate AR, and a liquid crystal layer LQ which is held between the array substrate AR and counter-substrate CT. The liquid crystal display device includes a plurality (m×n) of pixels PX which are arranged in a matrix in a display region DSP for displaying an image.

[0051] The array substrate AR is formed by using a light-transmissive insulating substrate. The array substrate AR includes, in the display region DSP, an (m×n) number of pixel electrodes EP which are disposed in association with the pixels, an n-number of scan lines Y (Y1 to Yn) which are formed in a row direction of the pixel electrodes EP, an m-number of signal lines X (X1 to Xm) which are formed in a column direction of the pixel electrodes EP, an (m×n) number of active switching elements W (e.g. N-channel type thin-film transistors) which are disposed near intersections between the scan lines Y and signal lines X in the respective pixels PX, and storage capacitance lines AY which are capacitive-coupled to the associated pixel electrodes EP so as to constitute storage capacitances CS in parallel to liquid crystal capacitances CLC.

[0052] The array substrate AR further includes, in a driving circuit region DCT in the vicinity of the display region DSP, at least a part of a scan line driver YD which is connected to the n-number of scan lines Y, and at least a part of a signal line driver XD which is connected to the m-number of signal lines X. The scan line driver YD successively supplies scan signals (driving signals) to the n-number of scan lines Y on the basis of the control by a controller CNT. The signal line driver XD supplies video signals (driving signals) to the m-number of signal lines X on the basis of the control by the controller CNT at a timing at which the switching elements W in each row are turned on by the scan signal. Thereby, the pixel electrodes EP in each row are set at pixel potentials corresponding to the video signals which are supplied via the associated switching elements W.

[0053] The pixel electrode EP is formed of a metal film with light reflectivity, such as aluminum, in a reflective part of each of a reflective liquid crystal display device and a transmissive liquid crystal display device. The pixel electrode EP, on the other hand, is formed of a metal film with light transmissivity, such as indium tin oxide (ITO), in a transmissive part of each of a transmissive liquid crystal display device and a transreflective liquid crystal display device. The pixel electrodes EP associated with all the pixels PX are covered with an alignment film 20.

[0054] On the other hand, the counter-substrate CT is formed by using a light-transmissive insulating substrate. The counter-substrate CT includes a counter-electrode ET in the display region DSP. The counter-electrode ET is disposed to be opposed to the pixel electrodes EP of all pixels PX. The counter-electrode ET is formed of a metal film with light transmissivity such as indium tin oxide (ITO). The counter-electrode ET is covered with an alignment film 30.

[0055] When the counter-substrate CT and array substrate AR are disposed such that their alignment films 20 and 30 face each other, a predetermined gap is provided by spacers (not shown) which are disposed between the alignment films 20 and 30. The liquid crystal layer LQ is composed of a liquid crystal composition including liquid crystal molecules 40 which are sealed in the gap between the alignment film 20 of the array substrate AR and the alignment film 30 of the counter-substrate CT. In this embodiment, the liquid crystal layer LQ is composed of a liquid crystal composition having a negative dielectric-constant anisotropy.

[0056] The alignment films 20 and 30 are formed of thin films of a light-transmissive resin material such as polyim-

ide. In this embodiment, the alignment films 20 and 30 are not subjected to rubbing treatment, and vertical alignment properties are imparted to the liquid crystal molecules included in the liquid crystal layer LQ.

[0057] In addition, in this embodiment, the liquid crystal display panel LPN has a multi-domain structure for dividing the direction of alignment into at least two directions in each pixel. Specifically, in this liquid crystal display panel LPN, as described above, the vertical alignment mode is adopted, in which liquid crystal molecules in each pixel are aligned substantially vertical to the substrate surface in a state in which no voltage is applied to the pixel or a voltage less than a threshold is applied to the pixel. With the provision of the multi-domain structure, in the state in which a voltage not less than the threshold is applied to the pixel, the liquid crystal molecules of the pixel are aligned oblique or substantially parallel to the substrate surface, and the direction of inclination is substantially determined by the direction of lines of electric force. In other words, with the multi-domain structure, the lines of electric force at peripheral parts of the multi-domain structure include components which do not extend vertical to the substrate surface but extend in different directions within the same pixel in dependence on, e.g. the shape of the multi-domain structure. Thus, the liquid crystal molecules are aligned in two or more directions within the same pixel.

[0058] This control of alignment can be realized by providing a protrusion, which functions as a multi-domain structure, within the pixel PX, as shown in FIG. 2. Alternatively, the control of alignment can be realized by providing a slit, which functions as a multi-domain structure, in a part of at least one of the pixel electrode EP and counter-electrode ET which are disposed in each pixel PX. Needless to say, the protrusion and the slit may be combined.

[0059] The protrusions 31 are provided, for example, on the counter-substrate CT side. The protrusions 31 may be rib structures extending in one direction of the pixels PX, as shown in FIG. 3A, or may have columnar or conical shapes and may be disposed at substantially central parts of the pixels PX, as shown in FIG. 3B.

[0060] In the liquid crystal display device having the above-described structure, gradation display of at least an n-number of gray levels, e.g. 256 gray levels, can be executed by stepwise varying the voltage that is to be applied to the pixel. A relationship, as shown in FIG. 8, is present between the 256 gray levels and the display luminance (the display luminance in the frontal direction in FIG. 8). The display luminance of a display image, relative to viewing angles, was measured when the display image was displayed at respective gray levels. The display luminance of the display surface at a time when a white image is displayed is set at 100 (%). The display luminance, which was measured at respective gray levels including intermediate gray levels between a black image gray level (gray level 0) and a white image gray level (gray level 255), was normalized.

[0061] FIG. 4A shows measurement results of the display luminance at respective gray levels in a right-and-left direction on the display surface. It was confirmed that the display luminance increases as the viewing angle gradually increases from the normal-directional angle, and that the difference between the display luminance of the white image

and the display luminance of an intermediate gradation image is very small at oblique viewing angles greater than a predetermined angle.

[0062] FIG. 4B shows measurement results of the display luminance at respective gray levels in an up-and-down direction, FIG. 4C shows measurement results of the display luminance at respective gray levels in an upper-right-and-lower-left direction on the display surface, and FIG. 4D shows measurement results of the display luminance at respective gray levels in an upper-left-and-lower-right direction on the display surface. These measurement results are substantially equal to the measurement results of the display luminance at respective gray levels in the right-and-left direction of the display surface, as shown in FIG. 4A. It was confirmed that the display luminance has isotropic viewing-angle characteristics.

[0063] Based on these measurement results, the inventor of the present invention paid attention to such characteristics that there is little difference in luminance between specific gray levels in any azimuth direction at oblique viewing angles greater than a predetermined angle. Specifically, attention was paid to the fact that in the liquid crystal display device according to the present embodiment, in a display luminance range of L_i to L_j in a normal direction to the display surface, which corresponds to a gradation range of predetermined gray levels i (light side) to j (dark side) of an n -number of gray levels, if a ratio of display luminance L_i to display luminance L_j is 150% or more, or $L_i/L_j \geq 1.5$, such viewing angle characteristics that a ratio of display luminance M_i to display luminance M_j is 130% or less (preferably 110% or less), or $M_i/M_j \geq 1.3$, are exhibited in a display luminance range of M_i to M_j in an oblique viewing-angle direction of 30° or more (n , i and j are real numbers, and $n \geq i > j \geq 0$). The liquid crystal display device according to the present embodiment, which is presupposed to have such viewing angle characteristics, has a display mode in which the display luminance range of the display image is limited to the range of L_i to L_j .

[0064] In this display mode, an image can be displayed by selecting, e.g. gray levels in a gradation range of i to j of the n gray levels. By displaying an image in this selected gradation range, the display luminance range becomes L_i to L_j in the normal direction to the display surface, while the ratio in display luminance becomes 130% or less in the oblique viewing-angle direction of 30° or more to the normal direction and the luminance greatly decreases. To be more specific, a display image is easily recognizable in a direction of a viewing angle of less than 30° from the normal direction to the display surface, while the display image is not easily recognizable in a direction of a viewing angle of 30° or more. In other words, this display mode corresponds to a narrow viewing angle mode in which the viewing-angle range, which permits recognition of a display image, is limited to less than 30° from the normal direction to the display surface. As is clear from the measurement results shown in FIG. 4A to FIG. 4D, in this narrow viewing angle mode, the characteristics of the display luminance relative to the viewing angles at respective gray levels are substantially isotropic. Therefore, in almost all azimuth directions, the viewing-angle range, which permits recognition of a display image, can be limited to less than a substantially equal angle (e.g. 30°).

[0065] On the other hand, an image can also be displayed at all displayable gray levels (gradation range of 0 to $n-1$). In this case, the display luminance range of the display image is L_0 to L_{n-1} . In a case where an image is displayed in this gradation range, the ratio in display luminance between gray levels in the normal direction to the display surface decreases as the tilt angle from the normal direction increases (i.e. the viewing angle increases), but a sufficient luminance is maintained even in a viewing-angle direction of 30° or more to the normal direction. Thus, the display image can be recognized in a wide viewing angle of more than 30° from the normal direction. In other words, this display mode corresponds to a wide viewing angle mode in which the viewing-angle range, which permits recognition of a display image, is increased to more than 30° from the normal direction to the display surface. As is clear from the measurement results shown in FIG. 4A to FIG. 4D, in this wide viewing angle mode, the characteristics of the display luminance relative to the viewing angles at respective gray levels are substantially isotropic. Therefore, in almost all azimuth directions, the viewing-angle range, which permits recognition of a display image, can be increased to a substantially equal angle.

[0066] In short, the liquid crystal display device according to the present embodiment has not only the wide viewing angle mode in which an image is displayed in a normally displayable luminance range (or in the entire displayable gradation range), but also the narrow viewing angle mode in which an image is displayed in a luminance range narrower than the normally displayable luminance range (or in a part of the displayable gradation range). By making use of the special viewing angle characteristics that are applied to the liquid crystal display device of the present embodiment, the following function can be realized. That is, the wide viewing angle characteristics are maintained at the time of normal display, and the display mode can be switched such that a sufficient visibility is obtained in the frontal direction while a visibility in any oblique direction is reduced and the viewing angle is limited.

[0067] To be more specific, as shown in FIG. 1, the liquid crystal display device according to the present embodiment includes a mode switching unit MS which functions as a switching means for effecting switching between the narrow viewing angle mode and the wide viewing angle mode. The mode switching unit MS has a function of switching the display mode on the basis of setting by the user. The mode switching unit MS may be a mechanical switch, or may be configured as a software switch which effects switching on the basis of input through a setting screen.

[0068] The controller CNT has a function of controlling the signal line driver XD and scan line driver YD so as to display an image on the basis of image data, which is supplied from outside, in a display mode which is selected by the mode switching unit MS (i.e. has a function of controlling voltages that are to be applied to pixels). For example, when the narrow viewing angle mode is selected, a control is executed to display an image in the gradation range of i to j . When the wide viewing angle mode is selected, a control is executed to display an image in the gradation range of 0 to $n-1$.

[0069] The controller CNT also has a function of data conversion means for converting image data of a display

image, which is displayed in a gradation range of 0 to $n-1$, to image data in a gradation range of i to j , upon the switching to the narrow viewing angle mode by the mode switching unit MS. For example, as shown in FIG. 5, the controller CNT converts image data, which is displayed in the gradation range of 256 gray levels from level 0 to level 255, to image data of 128 gray levels from level 128 to level 255 (i.e. $\frac{1}{2}$ of the gradation range of the original image data). At this time, the controller CNT assigns original image data of gray level 0 and gray level 1 to gray level 128, and assigns original image data of gray level 2 and gray level 3 to gray level 129. Similar assignment processes are repeated, and finally original image data of gray levels 254 and 255 is assigned to gray level 255. Thus, the gradation range of the original image data can be reduced to $\frac{1}{2}$. Alternatively, the controller CNT may convert original image data to some other gradation range of 128 gray levels. In like manner, the gradation range of original image data may be reduced to $\frac{1}{4}$, $\frac{1}{8}$, As described above, a gradation range, in which a difference in display luminance in oblique viewing-angle directions is small, is selected from the n -gray-level gradation range, and thereby the narrow viewing angle mode can be realized.

[0070] In the above-described example, in order to realize the narrow viewing angle mode, the controller CNT converts multi-gray-level image data of three or more gray levels to image data of a predetermined gradation range. In an example to be described below, a main image of a single gray level is displayed on a background image of a single gray level.

[0071] Specifically, upon switching to the narrow viewing angle mode by the mode switching unit MS, the controller CNT converts the gradation of at least one of a background image, which is displayed with a single gray level, and a main image, which is displayed with a single gray level, so that a difference in gradation between the background image and the main image may become smaller than in the wide viewing angle mode. The main image is a character image, for instance.

[0072] Assume now that original image data, which is supplied to the controller CNT, is binary gray-level image data, as shown in FIG. 6, in which the background image is a white image (gray level 255) and the main image is a black image (gray level 0) in the wide viewing angle mode.

[0073] In this case, as shown in FIG. 7A, the controller CNT does not change the gray level (gray level 255) of the background image, and converts the gray level of the main image from 0 to 155 (gray image). Alternatively, as shown in FIG. 7B, the controller CNT does not change the gray level (gray level 0) of the original image, and converts the gray level of the background image from 255 to 100 (gray image). Alternatively, as shown in FIG. 7C, the controller CNT converts the gray level of the background image from 255 to 200 (dense gray image) and converts the gray level of the main image from 0 to 100 (thin gray image).

[0074] By the conversion of image data, the difference of 255 between the gray levels of the background image and main image in the original image data is reduced to 100. Needless to say, the gradation range after conversion (i.e. the range between gray level 155 and gray level 255 in FIG. 7A, the range between gray level 0 and gray level 100 in FIG. 7B, and the range between gray level 100 and gray level 200

in FIG. 7C) is selected so that the difference in display luminance in oblique viewing-angle directions may become sufficiently small. Hence, the wide viewing angle mode, in which the difference between gray levels is 128 or more (preferably 100 or more), and the narrow viewing angle mode, in which the difference between gray levels is 128 or less (preferably 100 or less), can be realized.

[0075] In the example shown in FIG. 7A, in order to realize the narrow viewing angle mode, it is preferable to select such a gradation range after conversion that the display luminance range of the background image is 90 to 100 and the display luminance range of the character image is 50 to 90. In the example shown in FIG. 7B, in order to realize the narrow viewing angle mode, it is preferable to select such a gradation range after conversion that the display luminance range of the background image is 50 to 90 and the display luminance range of the character image is 90 to 100.

OTHER EMBODIMENT 1

[0076] In the above-described embodiment, when the controller CNT converts first image data of display image, which is displayed in the gradation range of 0 to $n-1$, to second image data in the gradation range of i to j , the controller CNT assigns two gray levels of the first image data to one gray level of the second image data. The invention, however, is not limited to this example. As regards the number of gray levels of the first image data, which are to be assigned to the second image data, the first data may be converted such that the number of gray levels on the higher gradation side of the first image data is smaller than the number of gray levels on the lower gradation side of the first image data.

[0077] For example, as shown in FIG. 9, the controller CNT converts first image data, which is displayed in the gradation range of 256 gray levels from level 0 to level 255, to second image data of a 24 gray-level range between 232 and 255 (i.e. about 10% of the gradation range of the first image data before conversion). At this time, as regards the lower gradation side, the controller CNT assigns the first image data of 28 gray levels from level 0 to level 27 to gray level 232, and assigns the first image data of 19 gray levels from level 28 to level 46 to gray level 233. On the other hand, as regards the higher gradation side, the controller CNT assigns the first image data of 8 gray levels from level 244 to level 251 to gray level 254, and assigns the first image data of 4 gray levels from level 252 to level 255 to gray level 255.

[0078] This conversion can be realized by converting the gradation of the first image data to the gradation of the second image data on the basis of a function of an order of 1 or more. Specifically, the above-described nonlinear conversion is achieved by executing conversion on the basis of a relationship,

$$L_{out} = a \cdot Lin^{\beta} + b$$

where Lin is a gradation (input gradation) of the first image data which is input to the controller CNT functioning as data conversion means, L_{out} is a gradation (output gradation) of second image data which is output from the controller CNT after conversion, and β is a gradient coefficient (number of order) ($\beta > 1$) (a and b are coefficients that are properly set).

[0079] As described above, the gradation range, in which a difference in display luminance in oblique viewing-angle directions is small, is selected from the n-gray-level gradation range, and thus an image is displayed. Thereby, the narrow viewing angle mode, in which the visibility in oblique directions is decreased, can be realized.

OTHER EMBODIMENT 2

[0080] The liquid crystal display panel LPN includes a plurality of kinds of color pixels in the case where the display device is applied not only to display of character images, but also to display of color images such as ordinary video. For example, the liquid crystal display panel LPN includes first color pixels which display an image in the gradation range of an n-number of gray levels in a first color, and second color pixels which display an image in the gradation range of the n-number of gray levels in a second color with a lower relative visibility than the first color. In this structure, when the narrow viewing angle mode is to be realized, the controller CNT does not need to convert, with respect to both the first and second color pixels, the first image data of a display image, which is displayed in the gradation range of gray levels 0 to n-1, uniformly to image data of the same gradation range. Specifically, in the narrow viewing angle mode, the controller CNT displays an image in a gradation range of i to j with respect to the first color pixel, and displays an image with respect to the second color pixel in a gradation range that is wider than the gradation range for the first color pixel. In other words, in the narrow viewing angle mode, in order to decrease the visibility in oblique viewing-angle directions, it is desirable to convert image data to a narrower gradation range, but the visibility of an image with a narrow gradation range is also decreased in the frontal direction. In order to secure the visibility in the frontal direction while decreasing the visibility in oblique directions, it is desirable to decrease the difference in luminance and to increase the gradation range. Thus, paying attention to the fact that the difference in luminance of a color with a low relative visibility is small even if the gradation range is increased, the controller CNT converts the first image data of the color with low relative visibility to second image data of a wider gradation range than a color with a high relative visibility.

[0081] For example, in the liquid crystal display panel LPN including red pixels, green pixels and blue pixels, the relative visibility of blue is lowest. Thus, as shown in FIG. 10, for example, when the controller CNT converts first image data, which is displayed in a 64 gray-level gradation range between level 0 and level 63, to second image data of a 24 gray-level gradation range between level 40 to level 63 with respect to the red pixel, the controller CNT converts first image data, which is displayed in the 64 gray-level gradation range, to second image data of a 29 gray-level gradation range between level 35 to level 63 with respect to the blue pixel. As regards the green pixel with the highest relative visibility, the controller CNT converts first image data, which is displayed in the 64 gray-level gradation range, to second image data of a narrowest gradation range, e.g. a 22 gray-level gradation range between level 42 to level 63.

[0082] With this structure, the narrow viewing angle mode is realized by lowering the visibility when the display image is observed in oblique directions, while the visibility (display quality) is improved when the display image is observed in the frontal direction.

OTHER EMBODIMENT 3

[0083] The controller CNT may convert a part of first image data of a display image, which is displayed in a gradation range of 0 to n-1, to second image data of the display image, which is displayed in a gradation range of i to j.

EXAMPLE 1

[0084] In the case where the first image data includes data corresponding to a description in which a plurality of characters are arranged, the controller CNT converts a part of characters of the description to image data of a gradation range of i to j. In this case, the other characters are displayed in an n-gray-level range of level 0 to level n-1. For example, "A" and "D" of a character string "ABCDE" are converted to the gradation range of i to j, by which the narrow viewing angle mode can be realized.

[0085] To be more specific, the controller CNT extracts at random some characters included in the input first image data, and outputs second image data in which the extracted characters are converted to display data in the gradation range of i to j and the other characters are converted to display data in the n-gray-level gradation range of 0 to n-1. Thereby, when the liquid crystal display panel LPN is observed in the frontal direction, "ABCDE" is visually recognized, as shown in FIG. 11A. However, when the liquid crystal display panel LPN is observed in oblique directions, the visibility of "A" and "D" decreases and the character string "ABCDE" can substantially be visually recognized only as "_BC_E", as shown in FIG. 11B. When the display panel is observed in an oblique direction, since the visibility of a part of characters is lowered, the other characters are visually recognized conspicuously. Thus, the meaning of the description of the display image can be made nonunderstandable.

[0086] In this example, characters of the character string, which are to be partly converted, are extracted at random by software. Alternatively, characters, which are, in particular, to be made nonunderstandable, may be selected by a user, for example, a creator of the description, and a specified part of the description may be converted so as to realize the narrow viewing angle mode. Assume now that there is a character string (description) "The Japanese team won today's game by a score of 3-1." Of the character string, for example, the score "3-1" and the win/loss result "won" are converted, as characters to be made nonunderstandable, to a display image in the gradation range of i to j, by which the narrow viewing angle mode can be realized. Thus, when the liquid crystal display panel LPN is observed in the frontal direction, the description "The Japanese team won today's game by a score of 3-1." can be visually recognized, as shown in FIG. 12A. However, when the liquid crystal display panel LPN is observed in the oblique direction, the visibility of the specific parts "3-1" and "won" is lowered and the description is merely recognized as "The Japanese team _today's game _", as shown in FIG. 12B. In this way, when the display panel is observed in the oblique direction, since the visibility of a part of characters is lowered, the other characters are visually recognized conspicuously. Thus, the meaning of the description of the display image can be made nonunderstandable.

EXAMPLE 2

[0087] In a case where first image data includes data corresponding to a character, the controller CNT converts a partial segment of the character to a display image in the gradation range of i to j . Assume now that the character is composed of four segments S1, S2, S3 and S4, as shown in FIG. 13. In this case, partial segments of the character, for example, two segments S2 and S4, which are symmetric about a point, are converted to the gradation range of i to j , by which the narrow viewing angle mode can be realized.

[0088] To be more specific, with respect to each of characters included in the input first image data, the controller CNT outputs second image data in which the two segments S2 and S4 are converted to the gradation range of i to j and the other segments S1 and S3 are converted to the n -gray-level gradation range of 0 to $n-1$. Thereby, when the liquid crystal display panel LPN is observed in the frontal direction, the character is correctly recognized, as shown in FIG. 14A. However, when the liquid crystal display panel LPN is observed in oblique directions, the visibility of the character is decreased, as shown in FIG. 14B. When the display panel is observed in an oblique direction, since the visibility of partial segments of the character is lowered, the other segments are visually recognized conspicuously. Thus, not only the visibility of the character is lowered, but also the meaning of the description, which is composed of the character string including the low-visibility character, can be made nonunderstandable.

EXAMPLE 3

[0089] The controller CNT converts a part of first image data corresponding to a geometrical part of a display image, which is displayed based on the first image data, to a gradation range of i to j . For example, the controller CNT converts geometrical parts of the first image data, that is, hatched parts in FIG. 15, which are included in the display image that is displayed based on the first image data, to the gradation range of i to j , by which the narrow viewing angle mode can be realized.

[0090] To be more specific, the controller CNT outputs second image data in which image data, which corresponds to geometrical parts of the input image data, is converted to the gradation range of i to j , and image data corresponding to the other parts is converted to an n -gray-level gradation range of 0 to $n-1$. Thereby, as shown in FIG. 16A, when the liquid crystal display panel LPN is observed in the frontal direction, the entirety of the display image based on the first image data can be visually recognized. However, when the liquid crystal display panel LPN is observed in the oblique direction, the visibility of the geometrical parts of the display image is lowered, as shown in FIG. 16B. Thus, when the liquid crystal display panel LPN is observed in the oblique direction, the visibility of the parts of the display image is lowered and the other parts of the display image are visually recognized conspicuously. Therefore, the content of the display image can be made nonunderstandable.

<Example of Structure of Controller>

[0091] A description is given of an example of the structure of the controller CNT, which is applicable to the foregoing embodiments in the case where not only an image of a character but also a color image, such as ordinary video, is to be displayed.

[0092] Image data (first image data) before conversion is, for example, of a YMCK (complementary colors+black) type, a YUV (luminance+chrominance) type, or an RGB (three primary colors of red, green and blue) type. The conversion of gradation can most suitably be executed for image data of the RGB (three primary colors) type. This agrees with the fact that the currently used liquid crystal display device adopts the color display format based on the three primary colors of RGB.

[0093] Specifically, in the controller CNT, as shown in FIG. 17, a conversion unit converts image data of a YUV-format, which is a general image data format, to an RGB-format data. Thereby, image data corresponding to the three primary colors of red (R), green (G) and blue (B) are converted to image data having data formats of 8-bit gradation ranges, respectively. Then, the controller CNT converts the gradations of the image data of R, G and B. These image data correspond to the first image data before gradation conversion in the above-described embodiments.

[0094] For example, the gradation of the R image data is converted on the basis of table 1. Similarly, the gradation of G image data is converted on the basis of table 2, and the gradation of B image data is converted on the basis of table 3. The image data, which have been converted based on tables 1 to 3, correspond to the second image data in the above-described embodiments.

[0095] FIG. 18A shows an example of table 1 for converting the gradation of the R image data. FIG. 18B shows an example of table 2 for converting the gradation of the G image data. FIG. 18C shows an example of table 3 for converting the gradation of the B image data. In tables 1 to 3, L_{in} indicates the gradation of image data before conversion, and L_{out} indicates the gradation of image data after conversion. In this example, the controller CNT converts an 8-bit gradation range to a predetermined range in a 6-bit gradation range.

[0096] For example, as regards the R image data, the controller CNT converts first image data, which is displayed in a 256-gray-level gradation range from level 0 to level 255, to 6-bit-format second image data of a 24-gray-level gradation range from level 40 to level 63. As regards the G image data, the controller CNT converts first image data, which is displayed in a 256-gray-level gradation range from level 0 to level 255, to 6-bit-format second image data of a 22-gray-level gradation range from level 42 to level 63. As regards the B image data, the controller CNT converts first image data, which is displayed in a 256-gray-level gradation range from level 0 to level 255, to 6-bit-format second image data of a 29-gray-level gradation range from level 35 to level 63. In this case, as described in connection with Embodiment 1, the controller CNT nonlinearly converts the gradation of the first image data to the gradation of the second image data.

[0097] The above-described tables are generated by a table generating unit in the controller CNT. The table generating unit generates the tables on the basis of a value ΔV_0 and a value S_0 , which can be set by the user, and a relational formula 1 as shown in FIG. 19. In this example, values β , ΔV_0 and S_0 are set at values shown in FIG. 20 with respect to each image data of R, G and B. In the relational formula 1, normalized gradation values are used. However, in an actual process, in the case of an n -gray-level gradation of, e.g. 256 gray levels, the relational formula 1 is applied by assuming

$$Sin=Lin/(n-1),$$

and output values are obtained by assuming

$$Sout=Lout/(n-1).$$

[0098] The value β is a parameter for determining a distribution of gray levels after conversion. By value β , the smallness in gradation reproduction width is corrected, and the appearance of the image is adjusted. As the value β is increased, a greater side of $Sout$ is emphasized (i.e. gray levels are distributed with greater intervals on the higher gradation side than on the lower gradation side). According to experiments by the inventor, the optimal value of β is 1.5. As shown in FIG. 20, β is set at 1.5 with respect to each of R, G and B.

[0099] The value $V0$ is a parameter for determining the degree of the viewing angle control effect. It is preferable to properly set $V0$ in accordance with the characteristics (liquid crystal mode, design, gradation setting, etc.) of the liquid crystal display panel LPN. The value $V0$ may take a value in the range between 0 and 1. As the value of $V0$ increases, the viewing angle control effect becomes greater but the appearance of the image in the frontal direction becomes poorer (i.e. the image appears to be thinner). In this example, $V0$ is a sum of a properly set value and $\Delta V0$. $\Delta V0$ can be set by the user. Normally, $\Delta V0=0$, but the value of $\Delta V0$ can be selected from five values (-0.1 , -0.05 , 0 , $+0.05$, and $+0.1$) through a first select unit. Thereby, the appearance of the image in the frontal direction and the viewing angle controllability in the oblique direction can be adjusted.

[0100] In this example, as shown in FIG. 20, $V0$ is set at different values for R, G and B, in addition to $\Delta V0$. The value $V0$ defines a lower limit of the gradation that is used after conversion. According to experiments by the inventor, $V0$ for blue (B) can be set to a lowest value. By applying a proper value of $V0$, the appearance of the image in the frontal direction and the viewing angle controllability in the oblique direction were successfully improved.

[0101] The value $S0$ is a minimum gradation value of an image. In general, gradation values are used in a range to the darkest gray level. Thus, in almost all cases, satisfactory results are obtained by using 0 (zero) as $S0$. In the structure shown in FIG. 17, the value of $S0$ can be set by a second select unit which selects one of zero and an output from a minimum Y-value detection unit which detects a minimum value of a Y value (luminance) of the image data before conversion (first image data). A method of using 0 and a method of using a value corresponding to the image can be switched. In the case of displaying motion video, if the parameter is dynamically varied, the video becomes unnatural. It is thus desirable to fix $S0$ at 0.

[0102] Based on these values and the relational formula, conversion characteristics for R, G and B, for example, as shown in FIG. 21, can be obtained. The table generating unit generates tables corresponding to these conversion characteristics, that is, tables as shown in FIGS. 18A to 18C. Outputs from tables 1, 2 and 3 are 6-bit (64 gray levels) image data.

[0103] In the controller CNT, the output values, which are converted on the basis of the tables, and output values, which are obtained by simple 2-bit cutting from the 8-bit gradation values that are converted to the RGB format in the conversion unit, are input to an image mixing unit.

[0104] Based on a mask data map which is a map of 1-bit data corresponding to the number of pixels of an image as shown in FIG. 15, the image mixing unit selects the converted data or the simple 2-bit cut data as the gradation values of the input data, depending on whether the mask data is 1 or 0. Then, the image mixing unit mixes the selected data and a background pattern, and outputs the mixed data to the liquid crystal display panel LPN.

[0105] According to the controller CNT with the above-described structure, the nonlinear conversion as described in connection with, e.g. Embodiment 1, can be realized by setting the value β in the table generating unit at a value greater than 1. As has been described in connection with Embodiment 2, the gradation ranges of the image data after conversion, which correspond to R, G and B, can be made different by properly setting the value $V0$. As has been described in connection with Embodiment 3, only a part of the image data can be converted to the narrow viewing angle mode by properly selecting the use of the converted data or the use of the simple 2-bit cut data, on the basis of the mask data map.

<Optimal Gradation Range in Narrow Viewing Angle Mode>

[0106] The gradation range which is selected for realizing the narrow viewing angle mode, that is, the gradation range of i to j , should preferably be a range of $n/2$ or less of the number n of displayable gray levels. In order to set such a gradation range, verification was conducted by using a liquid crystal display panel which actually displays an image.

[0107] To begin with, verification was conducted with respect to the viewing angle at which the liquid crystal display panel was observed in an oblique direction. Specifically, as shown in FIG. 22, two persons sit side by side, one of the persons holds a mobile terminal device that is equipped with the liquid crystal display panel LPN, and the other person peeps at the liquid crystal display panel LPN in a natural posture. At this time, the person, who holds the mobile terminal device, holds it so as to observe the liquid crystal display panel LPN in the front direction (i.e. normal direction). An angle θ (i.e. an angle relative to a normal direction), at which the other person peeps at the liquid crystal display panel LPN, was measured.

[0108] FIG. 23 shows a measurement result. As is clear from the measurement result, the oblique angle, at which the display screen is most frequently peeped at by a neighboring person when the two persons sit side by side, is 40° relative to the normal direction to the display screen.

[0109] Next, verification was conducted with respect to the gray levels at which the display image cannot be visually recognized when the liquid crystal display panel LPN of the above-described mode is observed in the oblique direction of 40° to the normal direction. Assume that the liquid crystal display panel LPN displays an image in a 6-bit gradation range, that is, a 64-gray-level gradation range. The gradation range of a background part of the display image is set at gray level 63 which corresponds to the maximum gradation (white). The liquid crystal display panel LPN displays an image in which the colors of characters mixed on the background part are set at evaluation gray levels L. The liquid crystal display panel LPN is observed in an oblique

direction of $\theta=40^\circ$. The levels L of the respective colors were gradually lowered (i.e. darkened) from level 63, and the gray levels, at which the characters were first recognized, were measured.

[0110] As shown in FIG. 24, it was confirmed that the character of red (R) could not be recognized in a gradation range to $L=40$, the character of green (G) could not be recognized in a gradation range to $L=42$, and the character of blue (B) could not be recognized in a gradation range to $L=35$. In other words, it was understood that with respect to each of the colors, the image displayed in the gradation range of i to j was hardly recognized when the gradation range of i to j was set at $n/2$ or less of the number n of displayable gray levels. In particular, when the gradation range of i to j for realizing the narrow viewing angle mode is to be set, if the maximum gray level i is set to be equal to the light-side maximum gray level of the n -number of gray levels, a wider gradation range can be set and the display quality at the time of observation in the frontal direction can be improved.

[0111] As described above, the present embodiment can realize the viewing angle control which can effect selective switching between the narrow viewing angle mode and the side viewing angle mode by making use of the viewing angle characteristics of the liquid crystal display device that is to be mounted. A liquid crystal panel for varying the viewing angle is not needed in addition to the liquid crystal display device for displaying an image. Therefore, the increase in cost of the display device and the increase in thickness, weight and power consumption of the entirety of the display device can be suppressed. The narrow viewing angle mode can be realized in all directions by using the liquid crystal display device with isotropic viewing angle characteristics and by displaying an image by selectively setting the display luminance range or gradation range, in which the difference in display luminance becomes sufficiently small in the oblique viewing-angle direction, at an angle greater than a predetermined angle relative to the normal direction to the display surface.

[0112] In particular, if the above-described liquid crystal display device is applied as a display device of a mobile terminal device such as a mobile phone, the display image is prevented from being peeped at by a nearby stranger.

[0113] The present invention is not limited directly to the above-described embodiments. In practice, the structural elements can be modified without departing from the spirit of the invention.

[0114] For example, the controller CNT may be image processing means which is composed of a CPU and software. An input image of a gradation range of 0 to $n-1$ is converted to a gradation range of i to j , or converted and supplied to the signal line driver. Thereby, the narrow viewing angle mode or the wide viewing angle mode is realized. The conversion of gradation may be applied to processing of all input data or a specific part of the input data.

[0115] The controller CNT, without departing from the spirit of the invention, may be an image generating device which includes a means for generating images of characters to be displayed, on the basis of input character codes, and has a function of generating characters with character image

gradations corresponding to the narrow viewing angle mode and the wide viewing angle mode, which are set by the mode switching unit MS. In this case, when the mode switching unit MS selects the narrow viewing angle mode, all character images may not be generated in the narrow viewing angle mode, and only a specific part of the character images may be converted to the narrow viewing angle mode.

[0116] In the embodiments, the number n of gray levels is set. Alternatively, the invention is applicable to the case of using analog signals having a continuously varying gradation. In this case, the gradation can be expressed by substituting real numbers for i and j .

[0117] When the above-described embodiments are applied to a transmissive liquid crystal display device, it is preferable to adopt such a structure that switching elements W are disposed at the respective reflective parts and transmissive parts and the voltages to be applied to the pixels are made individually controllable. Such a transmissive liquid crystal display device may be configured to display an image in a gradation range of i to j so that only the transmissive parts may realize the narrow viewing angle mode. In this case, it is desirable to effect such switching that the reflective parts display an image that is different from the image on the transmissive parts. Specifically, when the transmissive parts display an image in the gradation range of i to j , the reflective parts display an image different from the image on the transmissive parts, for example, a black raster image. This does not prevent the effect that a sufficiently visibility of a display image is obtained in the frontal direction of the transmissive display parts while the visibility of the image is greatly reduced in the oblique direction. Even if the image is peeped at, the content of the image is difficult to recognize.

[0118] As described above, various inventions can be made by properly combining the structural elements disclosed in the embodiments. Some structural elements may be omitted from all the structural elements disclosed in the embodiments. Furthermore, structural elements in different embodiments may properly be combined.

What is claimed is:

1. A liquid crystal display device having a gradation display function of at least an n -number of gray levels and having a viewing angle characteristic of $M_i/M_j \leq 1.3$ in a case where a display luminance range in a normal direction to a display surface in a gradation range of a gray level i to a gray level j is L_i to L_j and a display luminance range in an oblique viewing-angle direction of 30° or more is M_i to M_j (where n , i and j are real numbers, and $n \geq i > j \geq 0$),

wherein the liquid crystal display device has a display mode in which a display image is displayed with a display luminance range of the display image being limited to L_i to L_j .

2. The liquid crystal display device according to claim 1, wherein when the display luminance range in the normal direction to the display surface is L_i to L_j , $L_i/L_j \geq 1.5$.

3. The liquid crystal display device according to claim 1, wherein the display mode comprises a narrow viewing angle mode in which an image is displayed in a gradation range of i to j , and a wide viewing angle mode in which an image is displayed in a gradation range of 0 to $n-1$, and

the liquid crystal display device includes switching means for effecting switching between the narrow viewing angle mode and the wide viewing angle mode.

4. The liquid crystal display device according to claim 3, further comprising data conversion means for converting, upon switching to the narrow viewing angle mode by the switching means, image data of the display image, which is displayed in the gradation range of 0 to $n-1$, to image data of the gradation range of i to j .

5. The liquid crystal display device according to claim 4, wherein upon switching to the narrow viewing angle mode by the switching means, the data conversion means converts the gradation of at least one of a background image, which is displayed with a single gray level, and a main image, which is displayed with a single gray level, such that a difference in gradation between the background image and the main image becomes smaller than in the wide viewing angle mode.

6. The liquid crystal display device according to claim 1, wherein the liquid crystal display device comprises:

an array substrate including active switching elements and pixel electrodes in association with pixels;

a counter-substrate including a counter-electrode which is disposed to be opposed to the pixel electrodes;

a liquid crystal layer with a negative dielectric-constant anisotropy, which is held between the array substrate and the counter-substrate; and

a structure for dividing a direction of alignment into at least two directions in each of the pixels,

wherein liquid crystal molecules in each pixel are aligned substantially vertical to the substrate surface in a state in which no voltage is applied to the pixel or a voltage less than a threshold is applied to the pixel, the liquid crystal molecules in each pixel are aligned oblique or substantially parallel to the substrate surface in a state in which a voltage not less than the threshold is applied to the pixel, and the direction of inclination is substantially determined by a direction of lines of electric force.

7. The liquid crystal display device according to claim 1, wherein in the display mode, in a case where a display luminance in a normal direction to the display surface at a time when a white image is displayed is 100, a display luminance range of a background image is 90 to 100 and a display luminance range of a main image is 50 to 90, or the display luminance range of the background image is 50 to 90 and the display luminance range of the main image is 90 to 100.

8. A mobile terminal device comprising the liquid crystal display device according to claim 1.

9. The liquid crystal display device according to claim 1, further comprising data conversion means for converting first image data of the display image, which is displayed in

the gradation range of 0 to $n-1$, to second image data of the display image, which is displayed in the gradation range of i to j ,

wherein as regards a number of gray levels of the first image data, which are to be assigned to the second image data, the first data is converted such that the number of gray levels on a higher gradation side of the first image data is smaller than the number of gray levels on a lower gradation side of the first image data.

10. The liquid crystal display device according to claim 9, wherein the data conversion means converts the gradation of the first image data to the gradation of the second image data on the basis of a function of an order of 1 or more.

11. The liquid crystal display device according to claim 1, further comprising first color pixels which display an image in the gradation range of an n -number of gray levels in a first color, and second color pixels which display an image in the gradation range of the n -number of gray levels in a second color with a lower relative visibility than the first color, and

when the display mode is executed, an image is displayed in the gradation range of i to j with respect to the first color pixels, and an image is displayed with respect to the second color pixels in a gradation range that is wider than the gradation range for the first color pixels.

12. The liquid crystal display device according to claim 1, further comprising data conversion means for converting a part of first image data of the display image, which is displayed in the gradation range of 0 to $n-1$, to second image data of the display image, which is displayed in the gradation range of i to j .

13. The liquid crystal display device according to claim 12, wherein the first image data includes data corresponding to a description in which a plurality of characters are arranged, and

the data conversion means converts a part of characters of the description to the gradation range of i to j .

14. The liquid crystal display device according to claim 12, wherein the first image data includes data corresponding to a character, and

the data conversion means converts a segment of the character to the gradation range of i to j .

15. The liquid crystal display device according to claim 12, wherein the data conversion means converts a geometrical part of the first image data of the display image, which is displayed on the basis of the first image data, to the gradation range of i to j .

16. The liquid crystal display device according to claim 1, wherein the gradation range of i to j is a gradation range in which the number of gray levels is $n/2$ or less.

17. The liquid crystal display device according to claim 16, wherein the gray level i is equal to a light-side maximum gray level of the n -number of gray levels.

* * * * *

专利名称(译)	液晶显示装置		
公开(公告)号	US20070075950A1	公开(公告)日	2007-04-05
申请号	US11/468659	申请日	2006-08-30
[标]申请(专利权)人(译)	山田YOSHITAKA 渡边良一 木下MASAKI 渡边弘 藤林SADAYASU 吉田德宏		
申请(专利权)人(译)	山田YOSHITAKA 渡边良一 木下MASAKI 渡边弘 藤林SADAYASU 吉田德宏		
当前申请(专利权)人(译)	日本展示CENTRAL INC.		
[标]发明人	YAMADA YOSHITAKA WATANABE RYOICHI KINOSHITA MASAKI WATANABE YOSHIHIRO FUJIBAYASHI SADAYASU YOSHIDA NORIHIRO		
发明人	YAMADA, YOSHITAKA WATANABE, RYOICHI KINOSHITA, MASAKI WATANABE, YOSHIHIRO FUJIBAYASHI, SADAYASU YOSHIDA, NORIHIRO		
IPC分类号	G09G3/36		
CPC分类号	G02F1/1393 G09G3/2007 G09G3/3648 G09G2320/0271 G09G2320/0285 G09G2320/068 G09G2330/021 G09G2360/16		
优先权	2006062860 2006-03-08 JP 2005257954 2005-09-06 JP		
其他公开文献	US7663587		
外部链接	Espacenet USPTO		

摘要(译)

液晶显示装置具有至少n个灰度级的灰度显示功能，并且在显示器的法线方向上的显示亮度范围的情况下具有 $M_i/M_j \leq 1.3$ 的视角特性。预定灰度级i至j的灰度范围是 L_i 至 L_j ，并且倾斜视角方向上的显示亮度范围是 30° 或更大是 M_i 至 M_j （其中n，i和j是实数，并且 $n \geq i > j \geq 0$ ）。液晶显示装置具有显示模式，其中显示图像的显示亮度范围被限制为 L_i 至 L_j 。

