



(19) **United States**

(12) **Patent Application Publication**  
**Takahashi et al.**

(10) **Pub. No.: US 2003/0151714 A1**

(43) **Pub. Date: Aug. 14, 2003**

(54) **LIQUID CRYSTAL DISPLAY DEVICE**

**Publication Classification**

(75) Inventors: **Hideyuki Takahashi**, Saitama-ken (JP);  
**Yasuyuki Hanazawa**, Saitama-ken (JP);  
**Kohei Nagayama**, Saitama-ken (JP)

(51) **Int. Cl.<sup>7</sup> ..... G02F 1/136**

(52) **U.S. Cl. .... 349/153**

Correspondence Address:  
**OBLON, SPIVAK, MCCLELLAND, MAIER &  
NEUSTADT, P.C.**  
**1940 DUKE STREET**  
**ALEXANDRIA, VA 22314 (US)**

(57) **ABSTRACT**

(73) Assignee: **KABUSHIKI KAISHA TOSHIBA**,  
Tokyo (JP)

A liquid crystal display device includes a driving voltage supply line **115** connected to a transfer pad **116** through a contact hole **116a**. The contact hole **116a** is corroded under the open air in a prior art liquid crystal display device. According to the present invention, however, the contact hole **116a** is provided in an air tight space between a display area **103a** and a sealing material **300**, e.g., underneath the sealing material **300**. With this structure the contact hole **116a** is not exposed to the open air so that its resistance to corrosion is significantly improved.

(21) Appl. No.: **10/335,897**

(22) Filed: **Jan. 3, 2003**

(30) **Foreign Application Priority Data**

Jan. 8, 2002 (JP) ..... 2002-001357

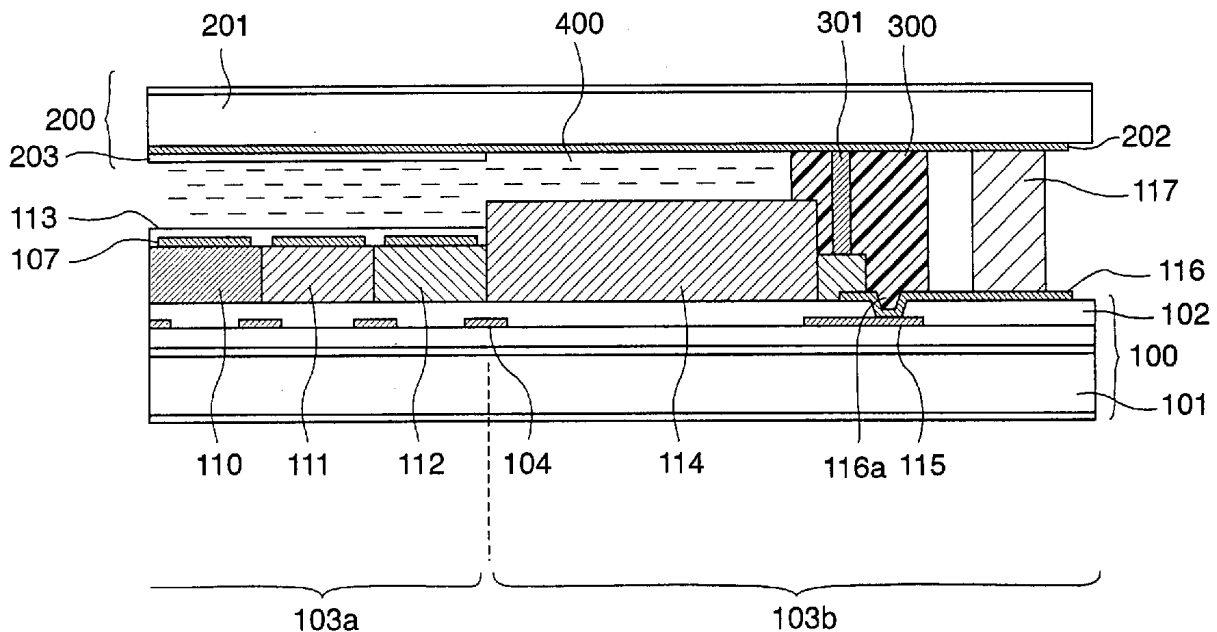

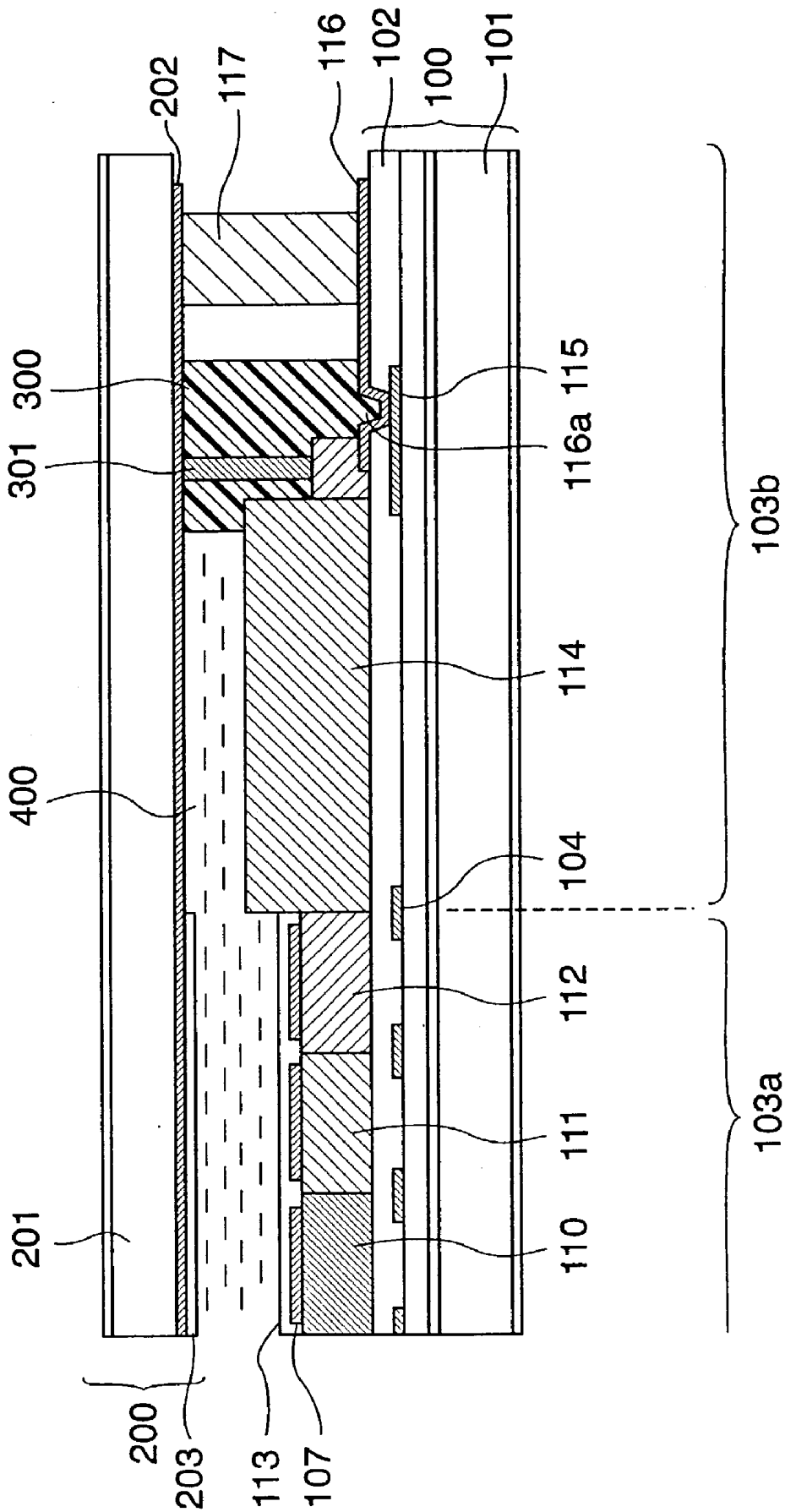

FIG.1

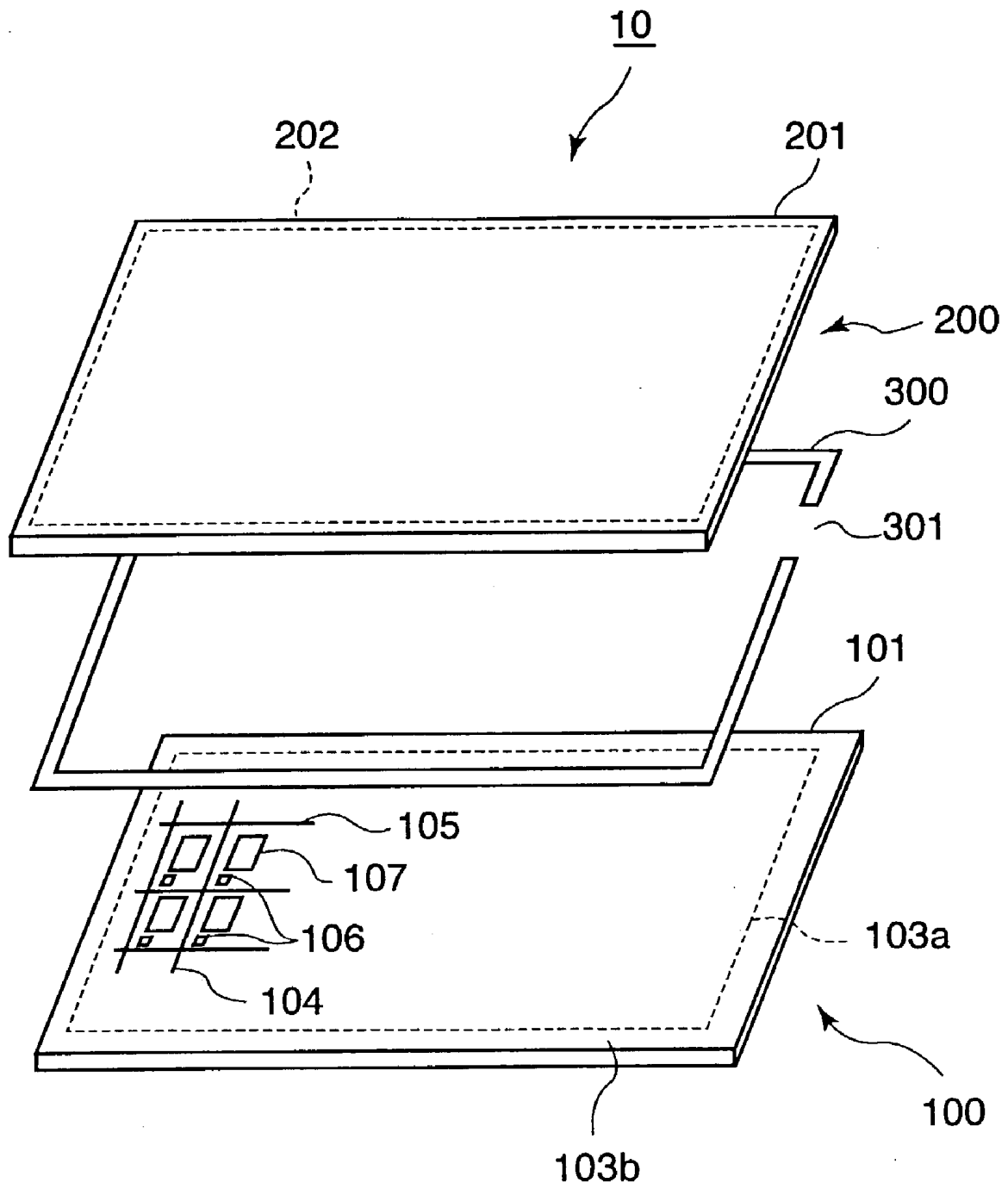

FIG.2

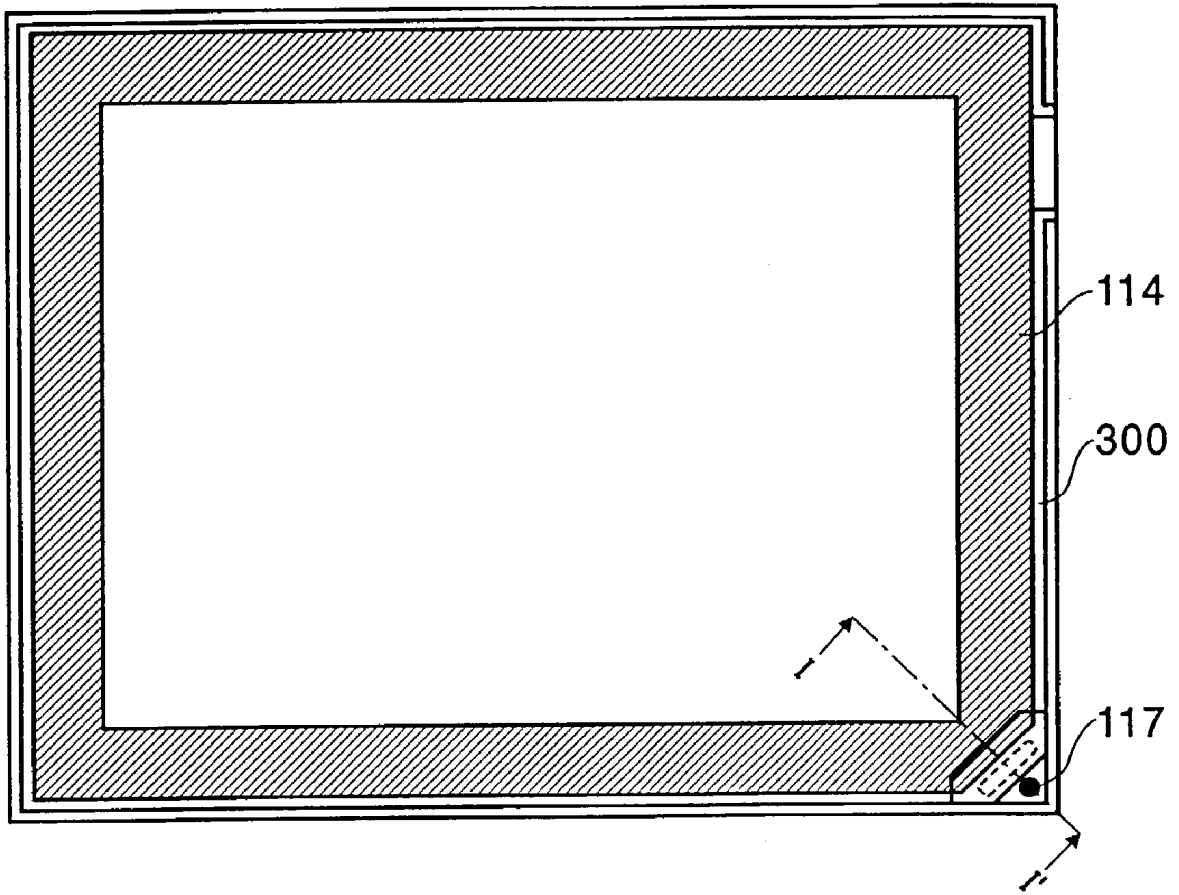

FIG.3

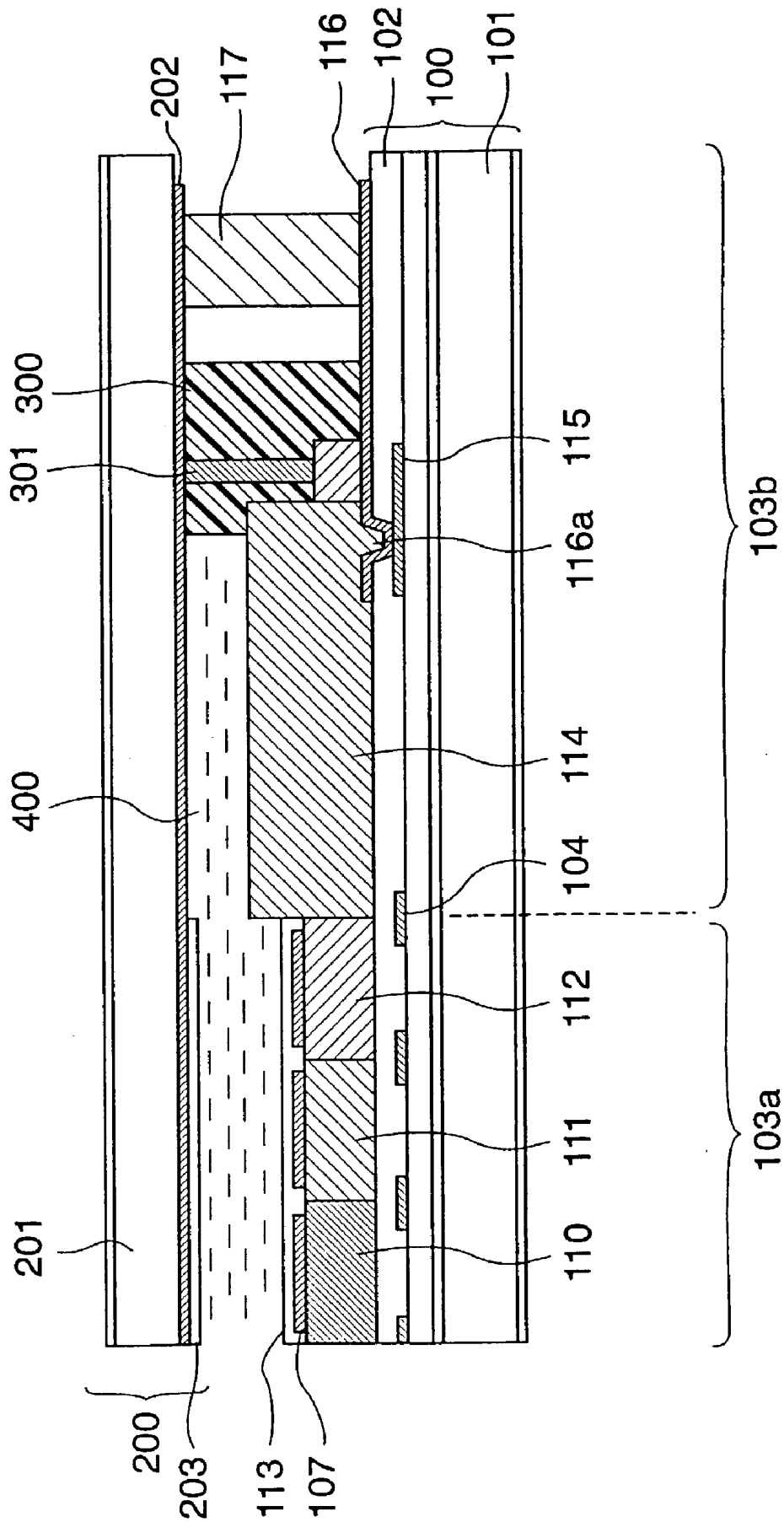

FIG.4

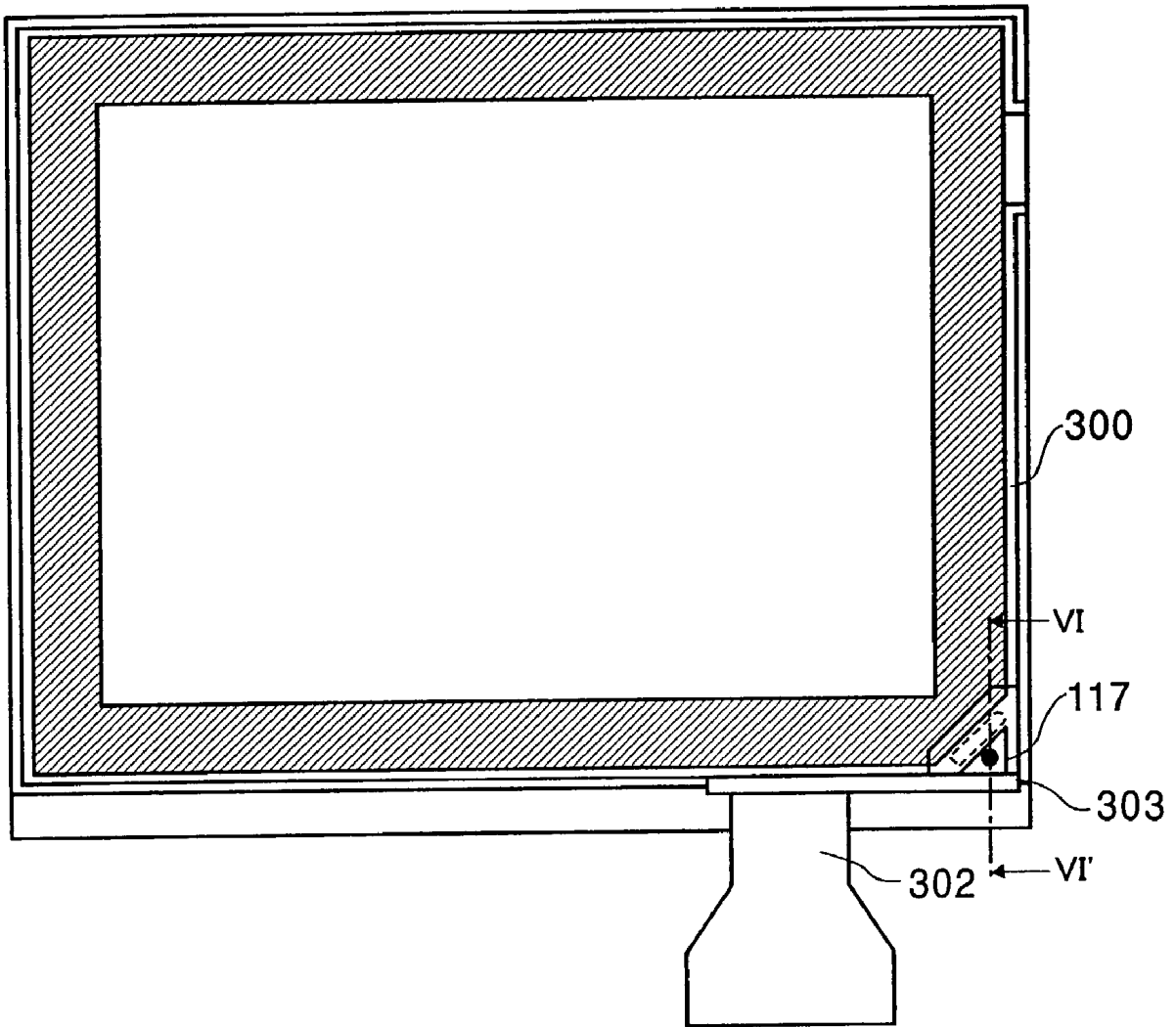

FIG.5

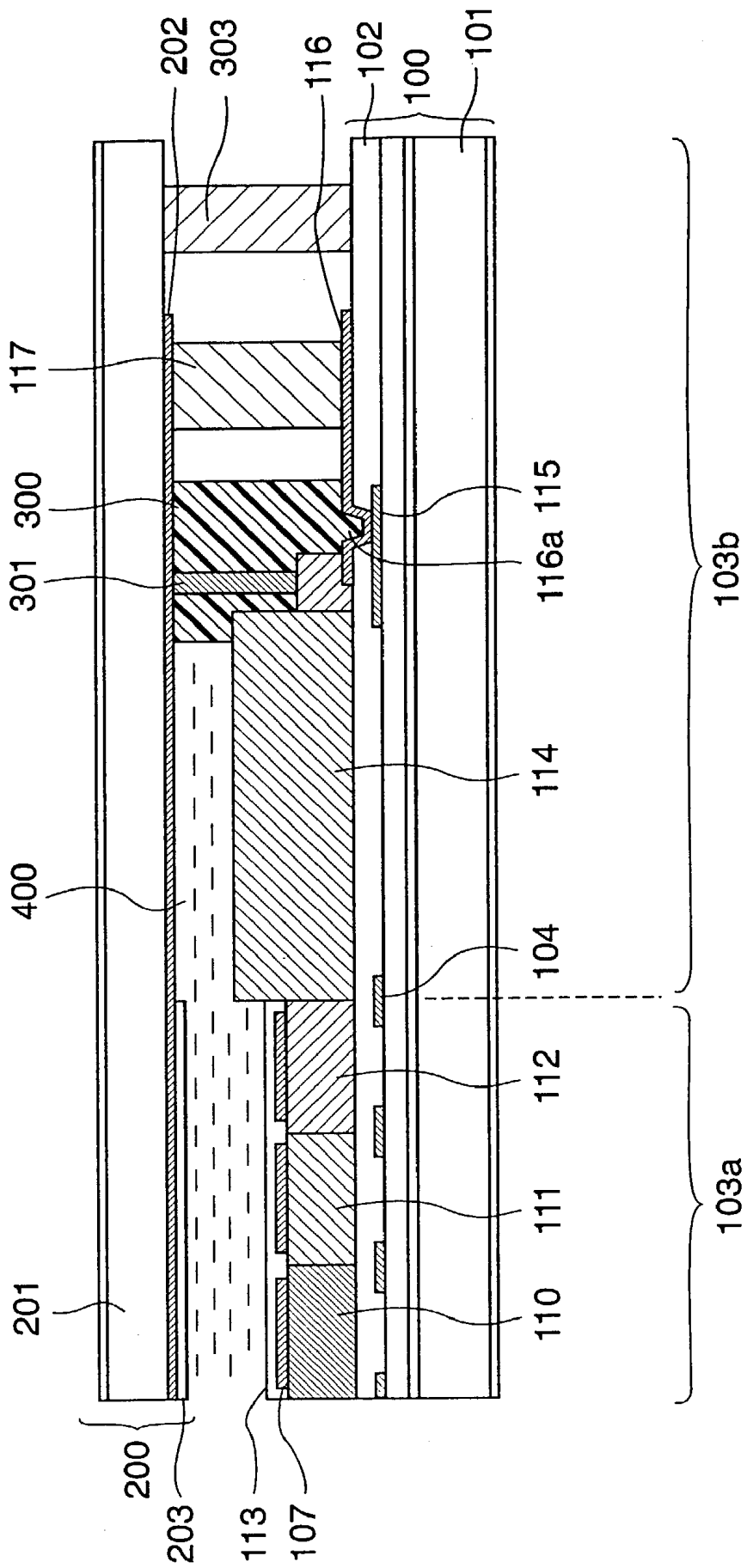

FIG.6

## LIQUID CRYSTAL DISPLAY DEVICE

### FIELD OF THE INVENTION

[0001] This invention generally relates to a liquid crystal display device and, in particular, to a liquid crystal display device with a transfer pad configured to supply driving voltages to an electrode of the display device through voltage supply lines.

### BACKGROUND OF THE INVENTION

[0002] Active matrix type liquid crystal display devices with thin film transistors to write data on every pixel have been becoming the main stream in liquid crystal display devices. An ordinary active matrix type liquid crystal display device includes a circuit array substrate provided with a plurality of pixel electrodes regularly arranged in the display area, a counter substrate provided with a counter electrode opposite to the pixel electrodes, a liquid crystal layer held between the array and counter substrates, and a sealing material to seal the liquid crystal layer at the periphery of the substrates.

[0003] At the edge portion of the array substrate, a transfer pad is provided for supplying a driving voltage to the counter electrode as an electrode connecting component. A transfer is also provided for electrically connecting the transfer pad to the counter electrode as an electrode transfer component. The driving voltage is supplied from an outside electric power source to the counter electrode through the transfer pad and the transfer.

[0004] A voltage supply line is disposed on the array substrate for supplying the driving voltage from the outside electric source to the transfer pad and is also connected to a contact hole formed on the transfer pad. According to a prior art liquid crystal display device, since the contact hole is arranged at the outside of sealing portions, it is exposed to the open air and easily corrodes away. As a result, the voltage supply lines become poor in electrical connection with the contact hole or a predetermined gap is defined between the transfer pad and an insulation layer formed underneath the transfer pad so that bubbles enter the liquid crystal layer and cause troubles such as deteriorations in electrical and/or optical characteristics and a poor picture display.

[0005] An object of the present invention is generally to provide a liquid crystal display device with the improvement of corrosion resistance with respect to a contact hole and with that of a good display quality.

### SUMMARY OF THE INVENTION

[0006] The present invention is directed to a liquid crystal display device which includes a circuit array substrate, a counter substrate provided opposite to the array substrate, and a liquid crystal layer. A plurality of pixel electrodes are formed within a picture display area on the array substrate. A counter electrode is formed on the counter substrate to face the pixel electrodes. The array and counter substrates are put together at a predetermined distance by sealing them with a sealing material at the periphery of the picture display area. A line and an electrode connecting component are formed on the array substrate to supply driving voltages to a counter electrode. The electrode connecting component

includes a contact hole to electrically contact the connecting component to the line. The electrode connecting component and the counter electrode are electrically connected through an electrode transfer component. The contact hole is disposed on a place between the picture display area and the sealing material.

[0007] The contact hole is placed on, and overlapped with, the plane of the sealing material. At least one set of the electrode contacting and electrode transfer components is provided for the liquid crystal display device. The electrode connecting component is formed outside of the sealing material and is disposed in a space defined by additional organic components. A part of the organic components is made of the sealing material. The contact hole is preferably polygonal or half-oval in cross section. The electrode connecting component and the line to supply a driving voltage to the counter electrode are preferably made of indium-tin-oxide (ITO) and aluminum materials, respectively.

### BRIEF DESCRIPTION OF THE DRAWINGS

[0008] FIG. 1 is a schematic sectional view taken along line I-I' of the liquid crystal display device shown in FIG. 3;

[0009] FIG. 2 is an exploded view of a liquid crystal display device;

[0010] FIG. 3 is a schematic plan view of an embodiment of the liquid crystal display device shown in FIG. 2;

[0011] FIG. 4 is a schematic sectional view of a liquid crystal display device which is a second embodiment of the present invention;

[0012] FIG. 5 is a schematic plan view of a liquid crystal display device which is a third embodiment of the invention; and

[0013] FIG. 6 is a sectional view taken along line IV-IV' of the liquid crystal display device shown in FIG. 5.

### DETAILED EXPLANATION OF THE INVENTION

[0014] Embodiments of a liquid crystal display device in accordance with the present invention are explained with reference to the attached drawings.

[0015] FIG. 2 is a schematic perspective view of unfolded components of a liquid crystal display device 10, FIG. 3 is a schematic plan view of the liquid crystal display device shown in FIG. 2 and FIG. 1 is a schematic sectional view along I-I' line of the liquid crystal display device shown in FIG. 3. Only major components are described in the attached drawings. Thus, the other peripheral ones are not shown for simplicity and explanations thereof are omitted. Now, descriptions will be made below with reference to FIGS. 1 through 3.

[0016] The liquid crystal display device 10 includes circuit array and counter substrates 100 and 200, a sealing material 300 and a liquid crystal 400 held in a space defined by the substrates 100 and 200 and the sealing material 300.

[0017] The array substrate is provided with a transparent glass substrate 101 and its plane is divided into two areas, i.e., a display area 103a and a frame area 103b. A plurality of signal lines 104 and a plurality of scanning lines 105 are disposed on the display area 103a in a matrix form through

an isolation layer **102**. A thin film transistor (TFT) **106** as a switching element and a pixel electrode **107** are provided to connect each other at each grid (cross point) of the matrix form. Green, blue and red color filters **110**, **111** and **112** made of organic resins are disposed in predetermined stripe patterns on the upper surface of isolation layer **102**. The pixel electrode **107** is formed on the color layers and an alignment layer **113** is provided to cover the pixel electrode **107**.

[0018] A black stripe **114** is formed at the frame area **103b** of the array substrate **100** to cut off incident light. The same layer as the signal line **104** includes driving circuits for signal and scanning lines not shown but to supply video signals to the pixel electrode **107** and a plurality of driving lines connected to driving circuits. A line **115** shown in FIG. 1 as one of the driving lines is provided to supply a counter voltage. The line **115** is made of aluminum in this embodiment.

[0019] A transfer pad **116** and a transfer **117** are disposed at the corner of the frame area **103b** for supplying a counter voltage to a counter electrode **202** and for electrically connecting the transfer pad **116** to the counter electrode **202**, respectively. The transfer pad **116** has a contact hole **116a** to electrically connect the pad **116** to the line **115**. The transfer pad **116** in the embodiment is made of indium-tin-oxide (ITO). The contact hole **116a** and the transfer pad **116** receive the sealing material **300** made of organic materials. The sectional configuration of the contact hole **116a** is not limited to a part of an oval as shown in the embodiment but may be that of a polygon.

[0020] The counter substrate **200** is made of a glass substrate as the array substrate **100** is. The counter electrode **202** is formed on the inner surface of the counter substrate **200** and is covered with an alignment layer **203**.

[0021] The array and counter substrates **100** and **200** are provided opposite to each other to define a cell with a predetermined gap held by a spacer column **301**. The sealing material **300** surrounding the panel periphery binds the array and counter substrates **100** and **200** together. After the substrates **100** and **200** have been bound by the sealing material, a liquid crystal material is injected into the cell from an inlet **301** defined between both edges of the sealing material **300** and a liquid crystal layer **400** is made.

[0022] In the liquid crystal display device **10**, a counter voltage supplied from the outside power source is provided to the counter electrode **202** through the line **115**, the contact hole **116a**, the transfer pad **116** and the transfer **117**. Since the contact hole **116a** is covered with the sealing material **300**, its surface is not exposed to the atmosphere (open air) so that its resistance to corrosion is significantly improved. Thus, the line **115** and the contact hole **116a** always maintain good electrical connection and no gap takes place between the transfer pad **116** and the isolation layer **102** so that it can prevent babbles from entering into the liquid crystal layer **400**. As a result, the liquid crystal display device according to the present invention brings about no substantial deterioration in electrical and optical characteristics but obtains a good display quality for a relatively long period of time.

[0023] Although the contact hole **116a** is disposed at such a place that the sealing material is overlapped with in the embodiment, it may be provided at any place between the edge of the display area **103a** and the underneath of the

sealing material **300**. For instance, the contact hole **116a** is disposed underneath the black stripe **114** as shown in FIG. 4. In this case, the surface of the contact hole **116a** is not exposed to the atmosphere, either, so that its resistance to corrosion is remarkably improved.

[0024] FIGS. 5 and 6 show a third embodiment of the present invention. FIG. 5 shows a schematic plan view of a liquid crystal display device. FIG. 6 is a sectional view taken along line IV-IV' of the liquid crystal display device shown in FIG. 5.

[0025] The liquid crystal display device includes a sealing material **300** surrounding a transfer pad **116** and a sealing member **303** of a flexible printed circuit board **302**. The flexible printed circuit board **302** is electrically connected to the driving lines on the array substrate **100**. Both sealing material **300** and sealing member **303** extend to define an airtight space to enclose the transfer pad **116**. With that structure, the contact hole **116a** can be fixed within such an airtight space even if a fixed place of the contact hole **116a** shifts to the outside of the sealing material **300**. Thus, the surface of the contact hole **116a** is not exposed to the open air. As a result, its resistance to corrosion is improved as in the previous embodiments. Although both of the sealing material **300** and the sealing member **303** of the flexible printed circuit board **302** extend to define the airtight space in this embodiment, the air tight space may be also defined by the sealing material **300**, only, or by other organic materials.

[0026] A pair of the transfer pad **116** and the transfer **117** are shown as an example but two pairs of them or more may be also provided to achieve the same function and effect.

[0027] The present invention is applicable not specifically to a liquid crystal display device but also generally to other flat panel display devices with the same or similar electrode structure. Thus, a liquid crystal display device means itself and may also mean its equivalence as well.

[0028] According to the present invention, a contact hole to connect one component to the other is not exposed to the open air so that its resistance to corrosion can be greatly improved. Thus, a driving voltage supply line and the contact hole always maintain good electrical connection and a transfer pad and an isolation layer define no gap to prevent babbles from entering into a liquid crystal layer in the case of a liquid crystal display device. As a result, a flat panel display device of the present invention does not cause poor electrical and optical characteristics but a good display quality for a long period of time.

What we claim is:

1. A liquid crystal display device comprising:

- a circuit array substrate including a plurality of pixel electrodes in a display area of said array substrate;
- a counter substrate including a counter electrode provided opposite to said pixel electrodes;
- a sealing material provided at a periphery of said display area to bind said array and counter substrates together with a predetermined gap;
- a liquid crystal layer filled in a space defined said array and counter substrates;

a line formed on said array substrate to supply a counter voltage to said counter electrode;

a connecting component formed on said array substrate to connect said line to a contact hole defined in said connecting component; and

a transfer component to electrically connect said counter electrode to said connecting component,

wherein said contact hole is provided between said display area and said sealing material.

2. The liquid crystal display device according to claim 1, wherein said contact hole is provided underneath said sealing material.

3. The liquid crystal display device according to claim 1 or 2, wherein at least a pair of said line and transfer component are provided.

4. The liquid crystal display device according to claims 1, 2, or 3, further comprising organic materials to define an airtight space with said sealing material, wherein said lines is provided in said space.

5. The liquid crystal display device according to claims 4, wherein said organic material is made of a part of said sealing material.

\* \* \* \* \*

专利名称(译)	液晶显示装置		
公开(公告)号	<a href="#">US20030151714A1</a>	公开(公告)日	2003-08-14
申请号	US10/335897	申请日	2003-01-03
[标]申请(专利权)人(译)	株式会社东芝		
申请(专利权)人(译)	株式会社东芝		
当前申请(专利权)人(译)	株式会社东芝		
[标]发明人	TAKAHASHI HIDEYUKI HANAZAWA YASUYUKI NAGAYAMA KOHEI		
发明人	TAKAHASHI, HIDEYUKI HANAZAWA, YASUYUKI NAGAYAMA, KOHEI		
IPC分类号	G02F1/1339 G02F1/1345 G09F9/30 G09F9/35 G02F1/136		
CPC分类号	G02F1/1345 G02F1/1339		
优先权	2002001357 2002-01-08 JP		
其他公开文献	US6906771		
外部链接	<a href="#">Espacenet</a> <a href="#">USPTO</a>		

摘要(译)

液晶显示装置包括通过接触孔116a连接到转移垫116的驱动电压供应线115。在现有技术的液晶显示装置中，接触孔116a在露天下被腐蚀。然而，根据本发明，接触孔116a设置在显示区域103a和密封材料300之间的气密空间中，例如，在密封材料300下面。利用这种结构，接触孔116a不暴露于密封材料300下面。露天使其耐腐蚀性得到显著改善。

