



US 20020071081A1

(19) **United States**

(12) **Patent Application Publication**
Cheng

(10) **Pub. No.: US 2002/0071081 A1**

(43) **Pub. Date: Jun. 13, 2002**

(54) **LIQUID CRYSTAL DISPLAY WITH WIDE VIEWING ANGLE**

(52) **U.S. Cl. 349/141**

(76) **Inventor: Hsin-An Cheng, Linyuan Shiang (TW)**

(57) **ABSTRACT**

Correspondence Address:
RABIN & CHAMPAGNE, PC
1101 14TH STREET, NW
SUITE 500
WASHINGTON, DC 20005 (US)

A liquid crystal display (LCD) having an oblique electric field while a voltage is applied between the upper plate and the lower plate of the LCD is disclosed. The LCD includes a first bias instrument of the upper plate and the second bias instrument of the lower plate. As no voltage between the upper and lower plate, the liquid crystal molecules in the proximity of the first and the second bias instrument are perpendicular to the upper and the lower plate. After an voltage is applied, an oblique electric field is produced by these bias instruments. The liquid crystal molecules are then rotated to parallel to the upper and lower plates because of the oblique electric field. The first and second bias instruments are bumps made of dielectric material or slits of electrodes.

(21) **Appl. No.: 10/013,515**

(22) **Filed: Dec. 13, 2001**

(30) **Foreign Application Priority Data**

Dec. 13, 2000 (TW)..... 89126649

Publication Classification

(51) **Int. Cl.⁷ G02F 1/1343**

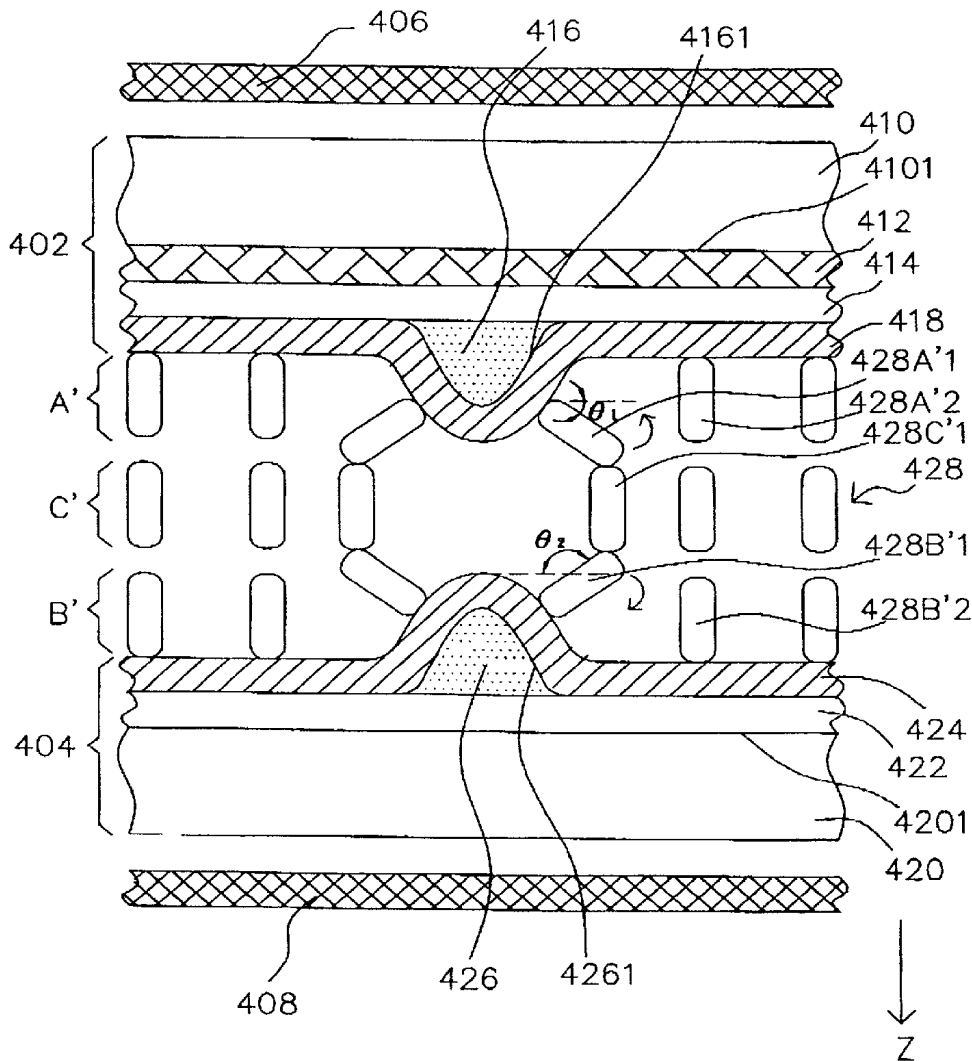

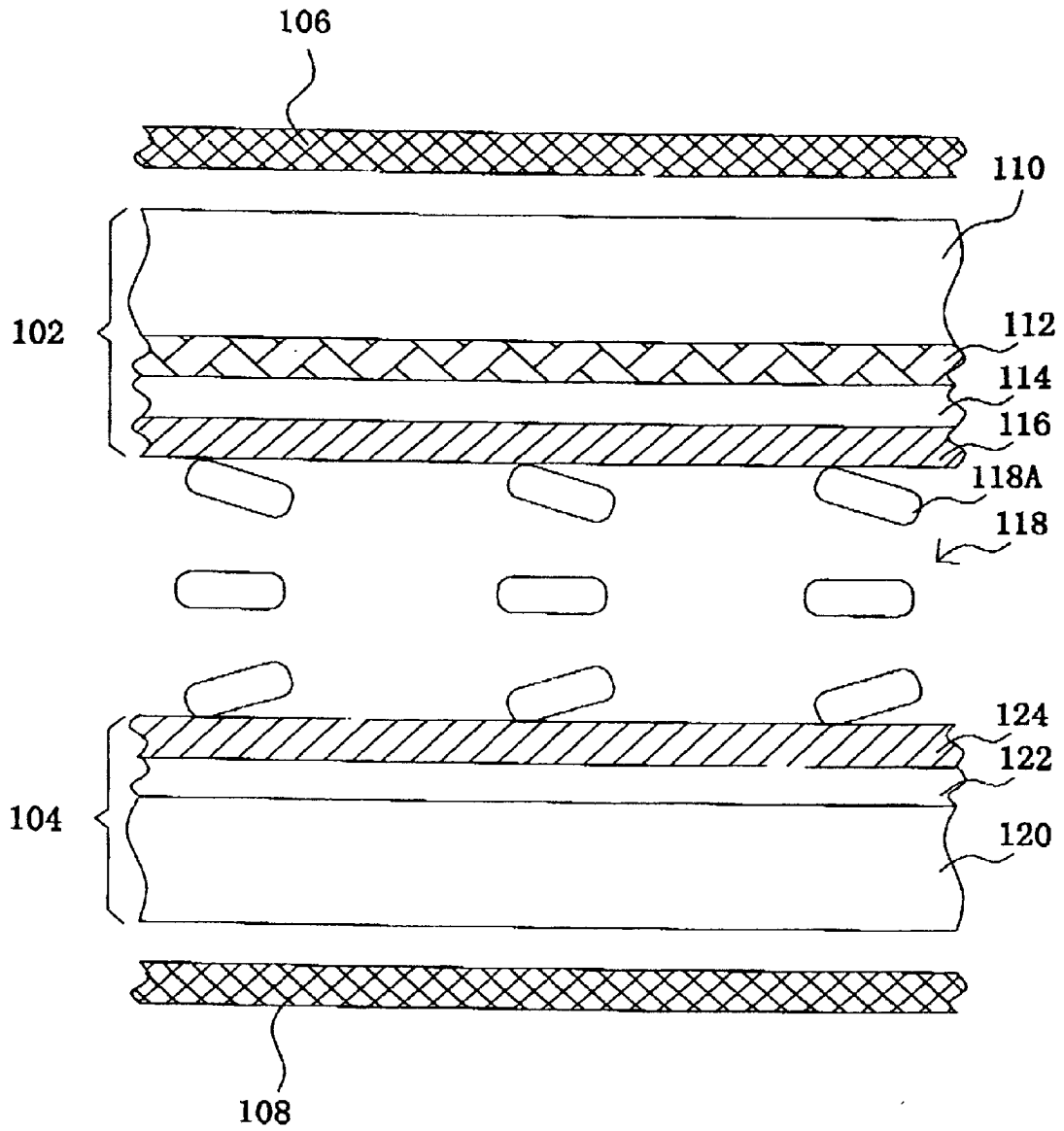

FIG. 1 (Prior Art)

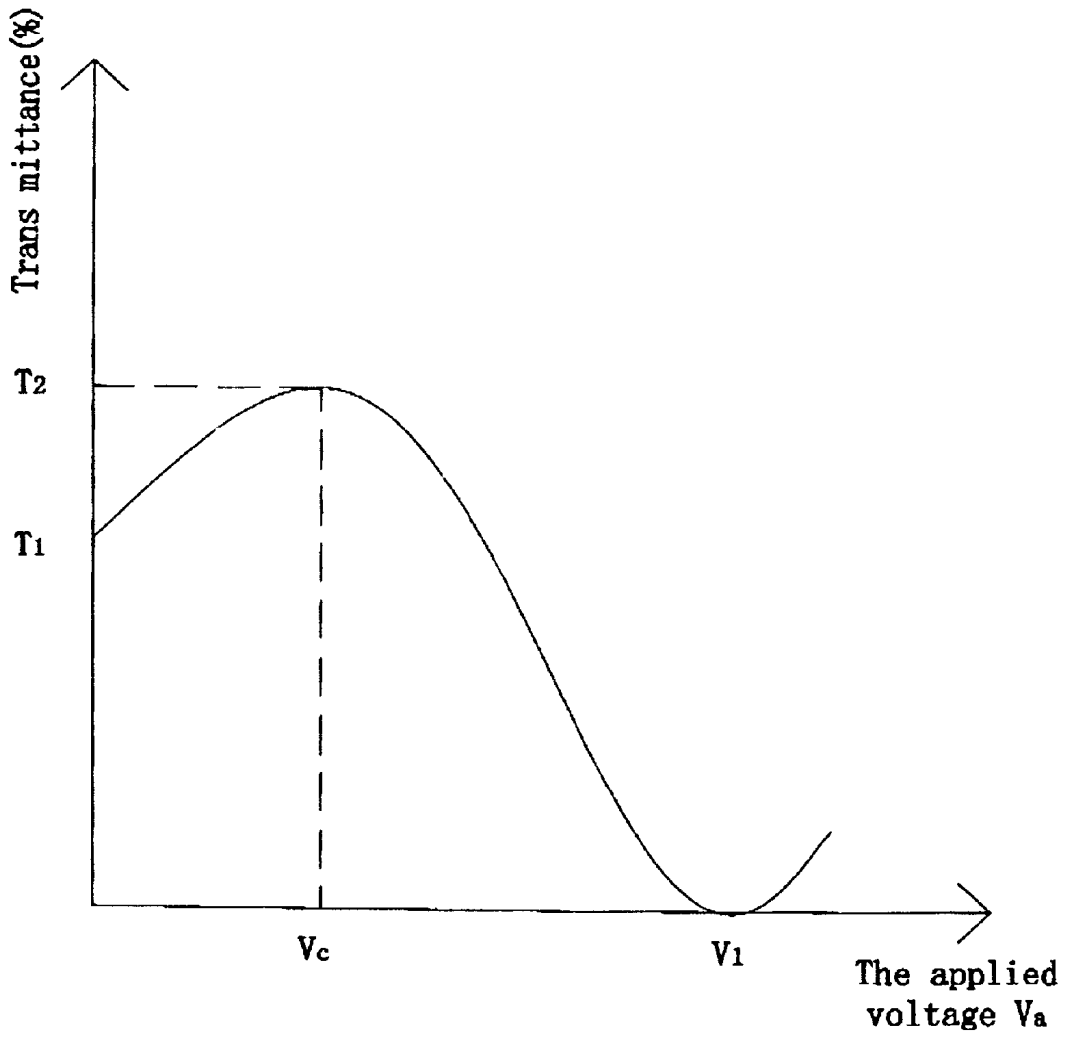

FIG. 2 (Prior Art)

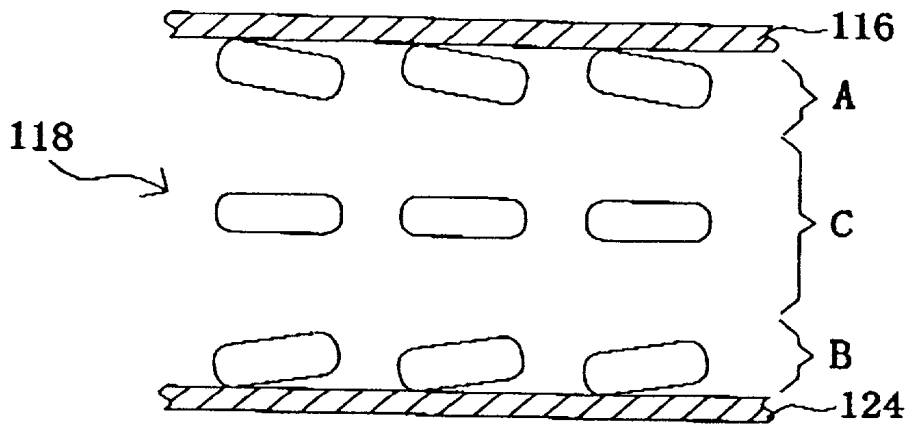

FIG. 3A (Prior Art)

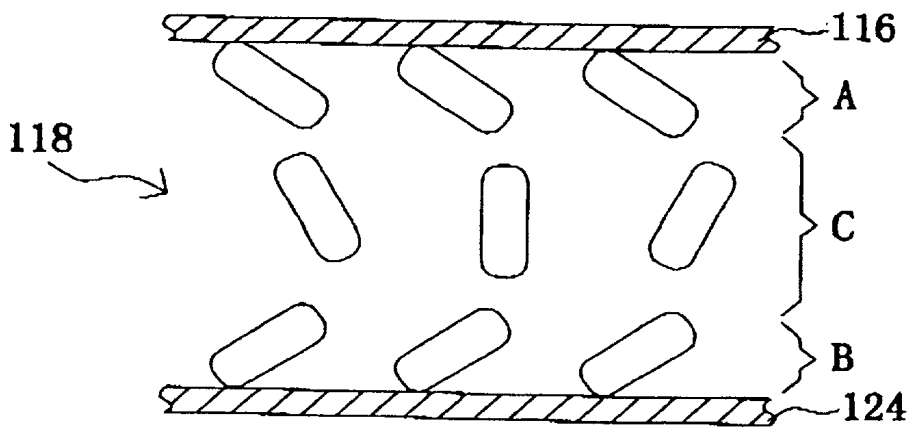
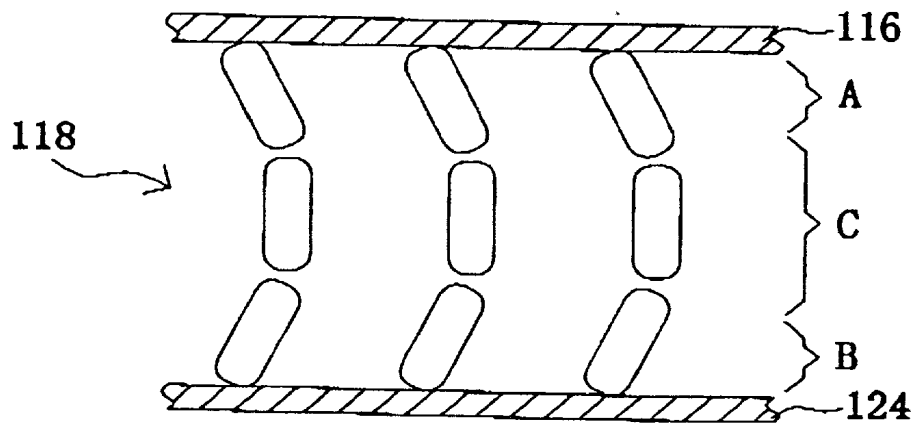

FIG. 3B (Prior Art)



FIB. 3C (Prior Art)

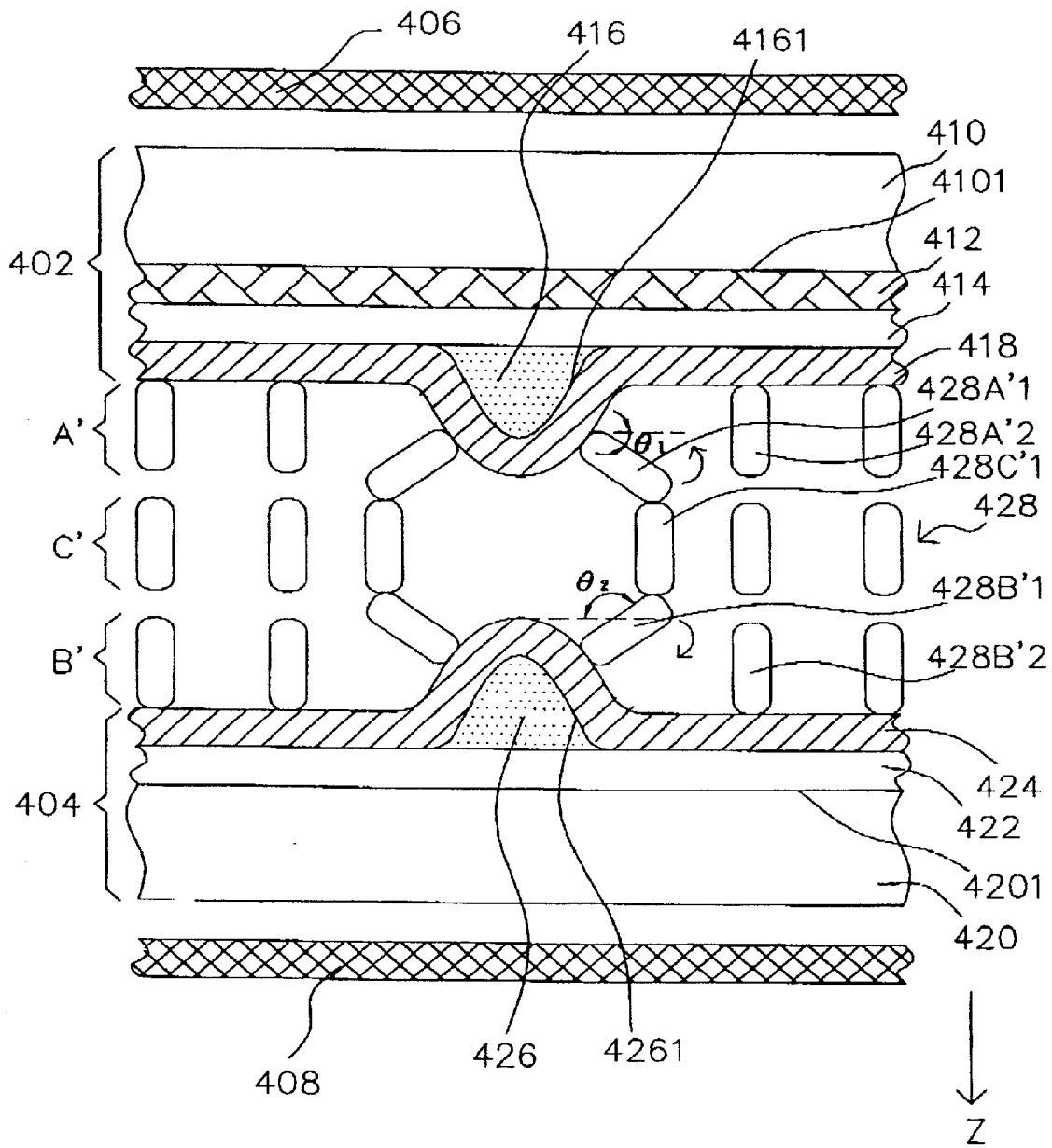

FIG. 4

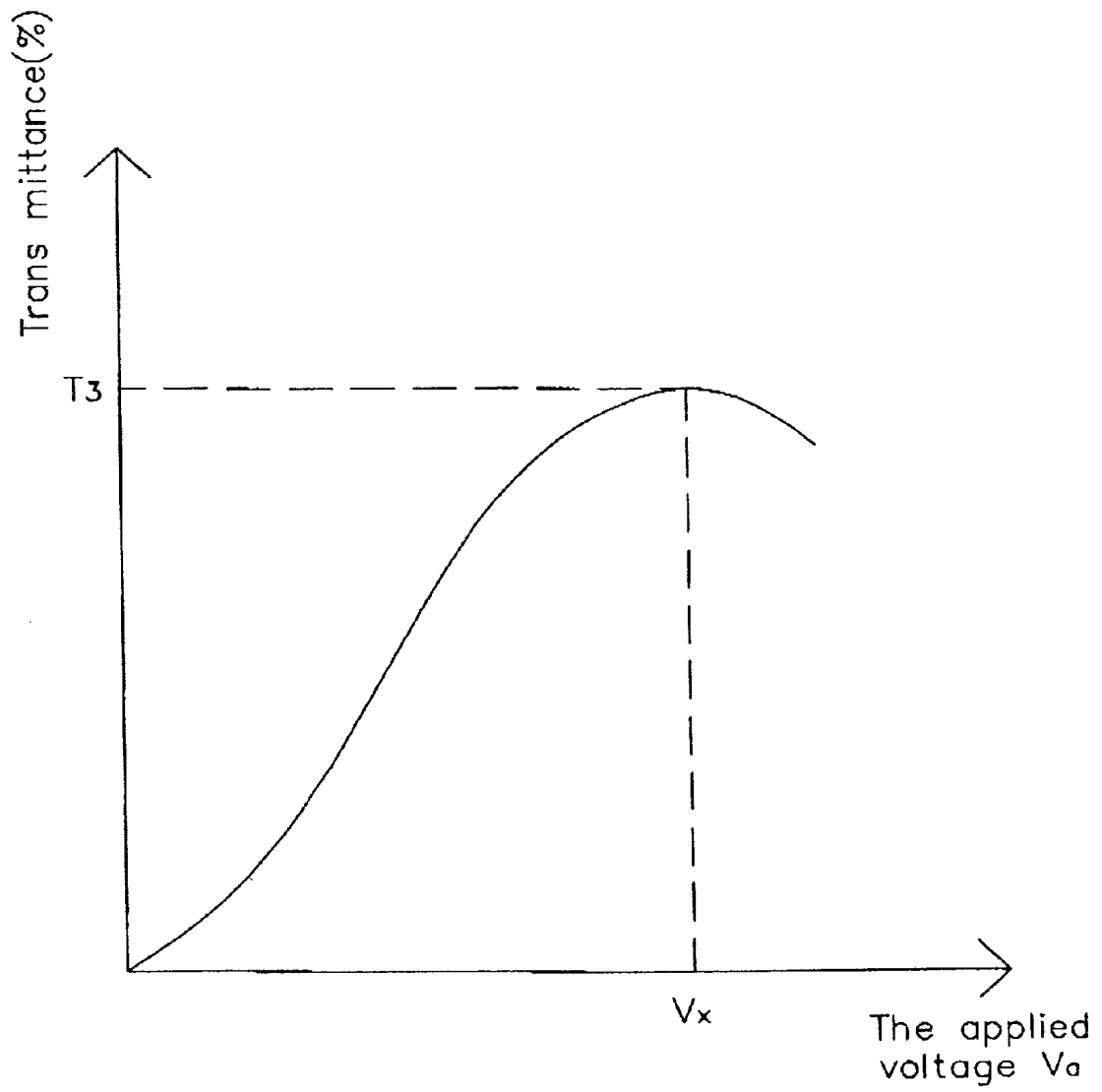

FIG. 5

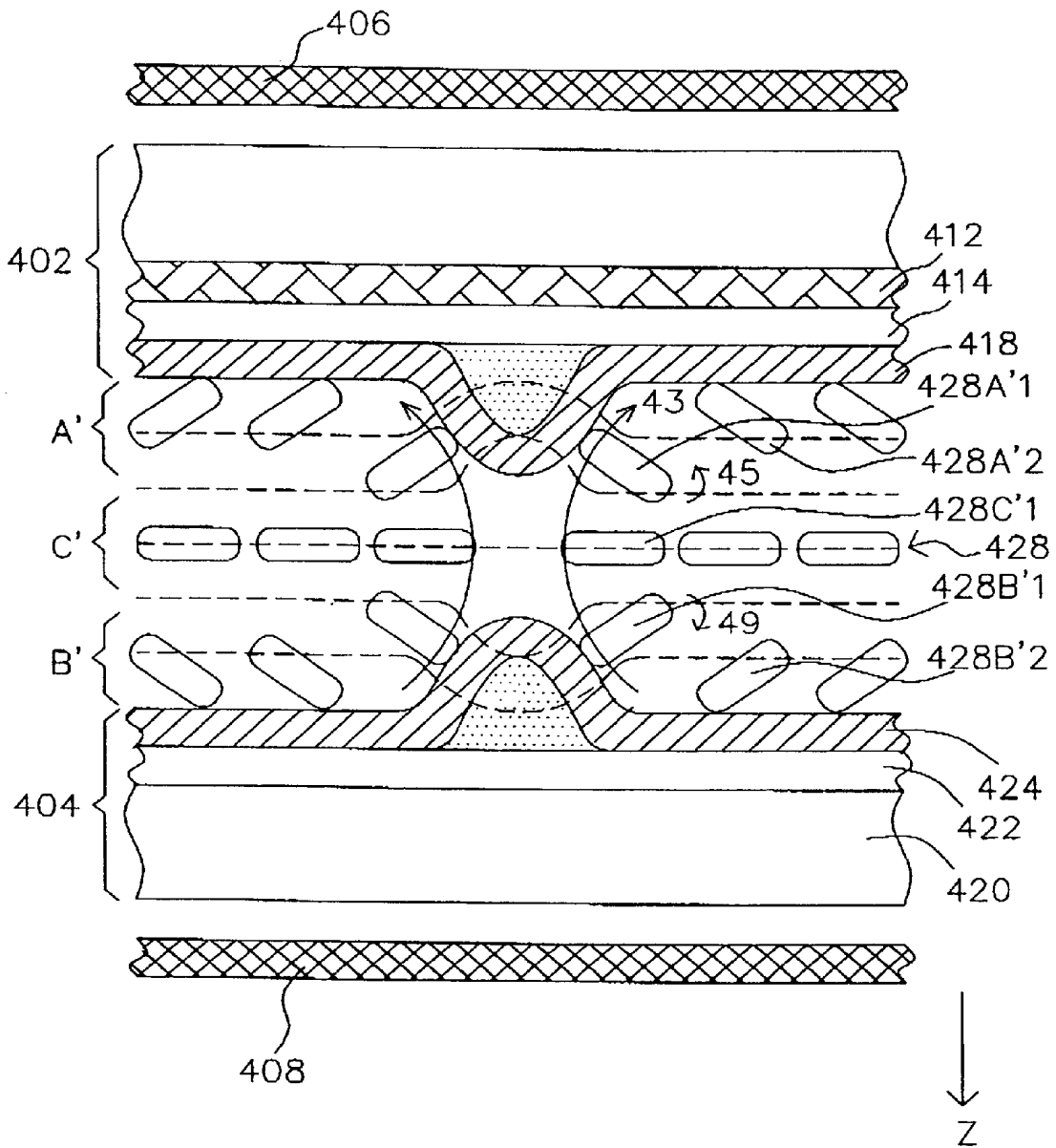

FIG. 6

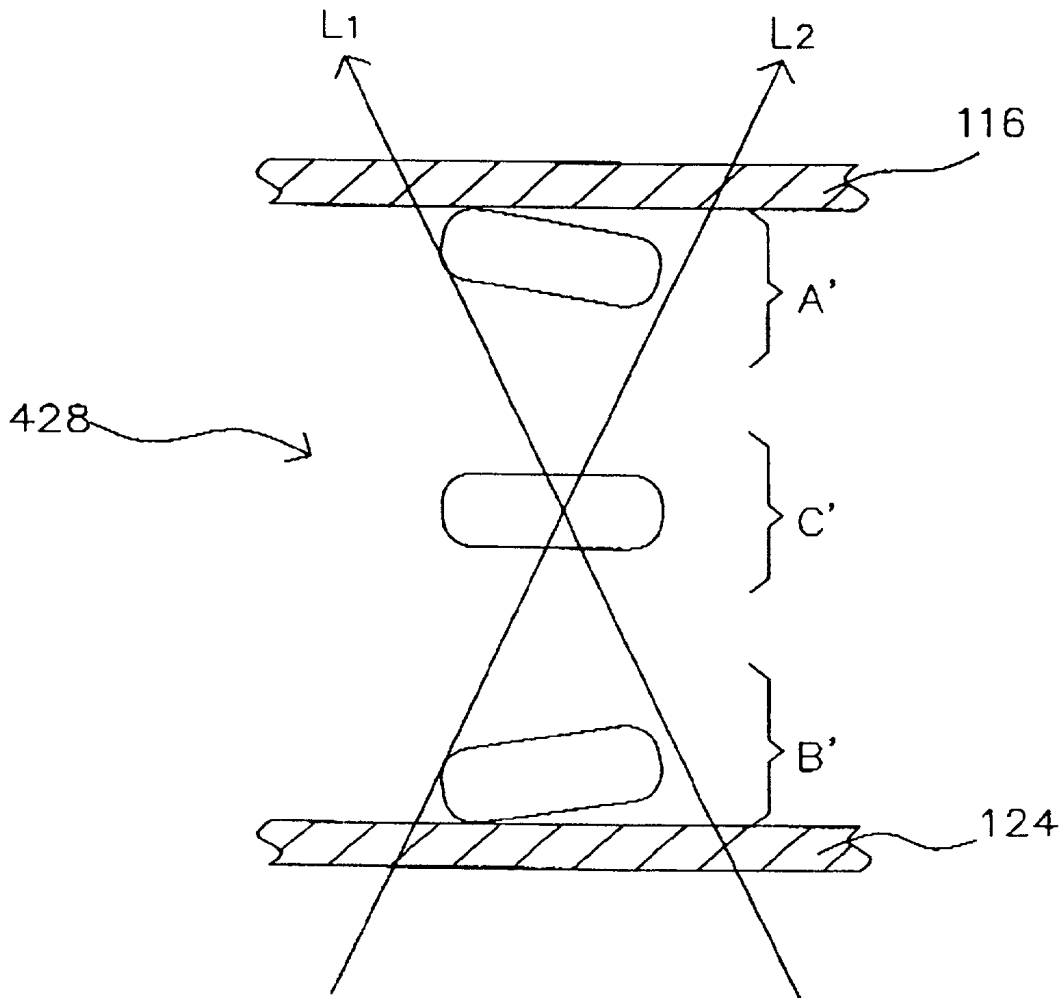

FIG. 7

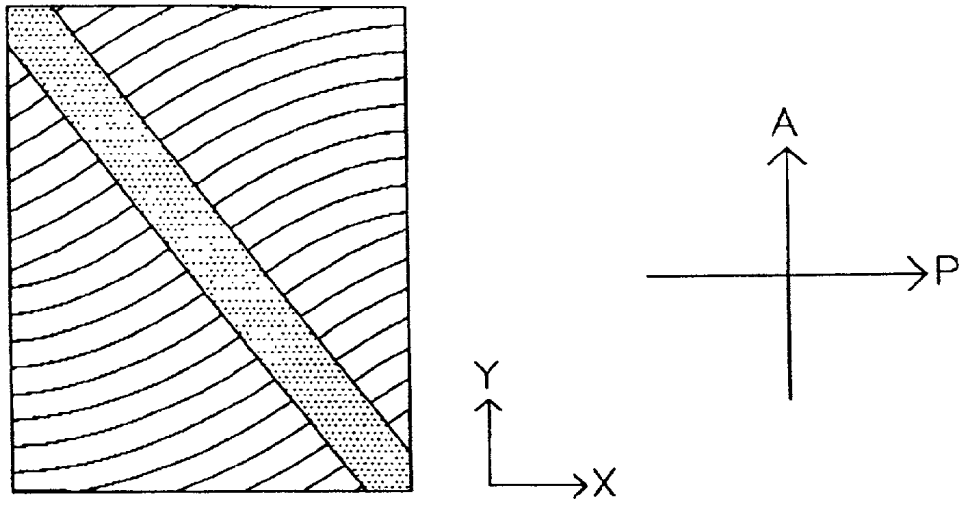

FIG. 8A

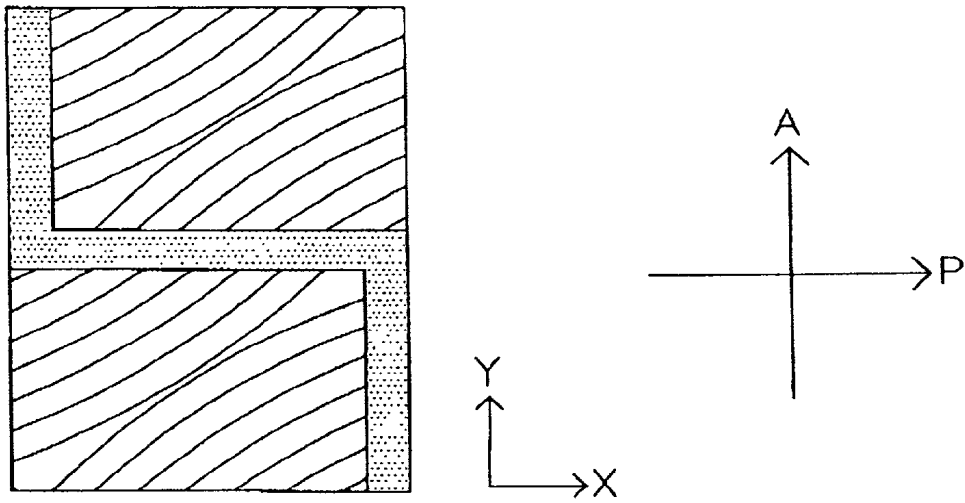

FIG. 8B

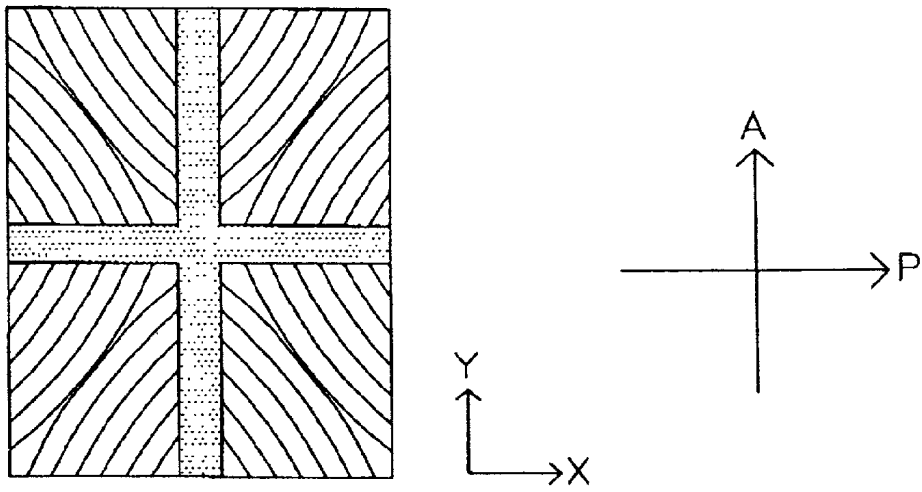

FIG. 8C

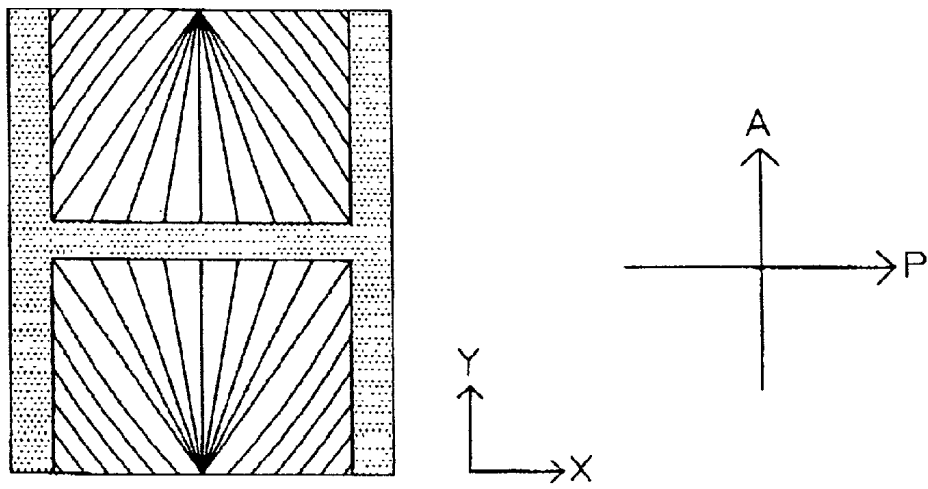

FIG. 8D

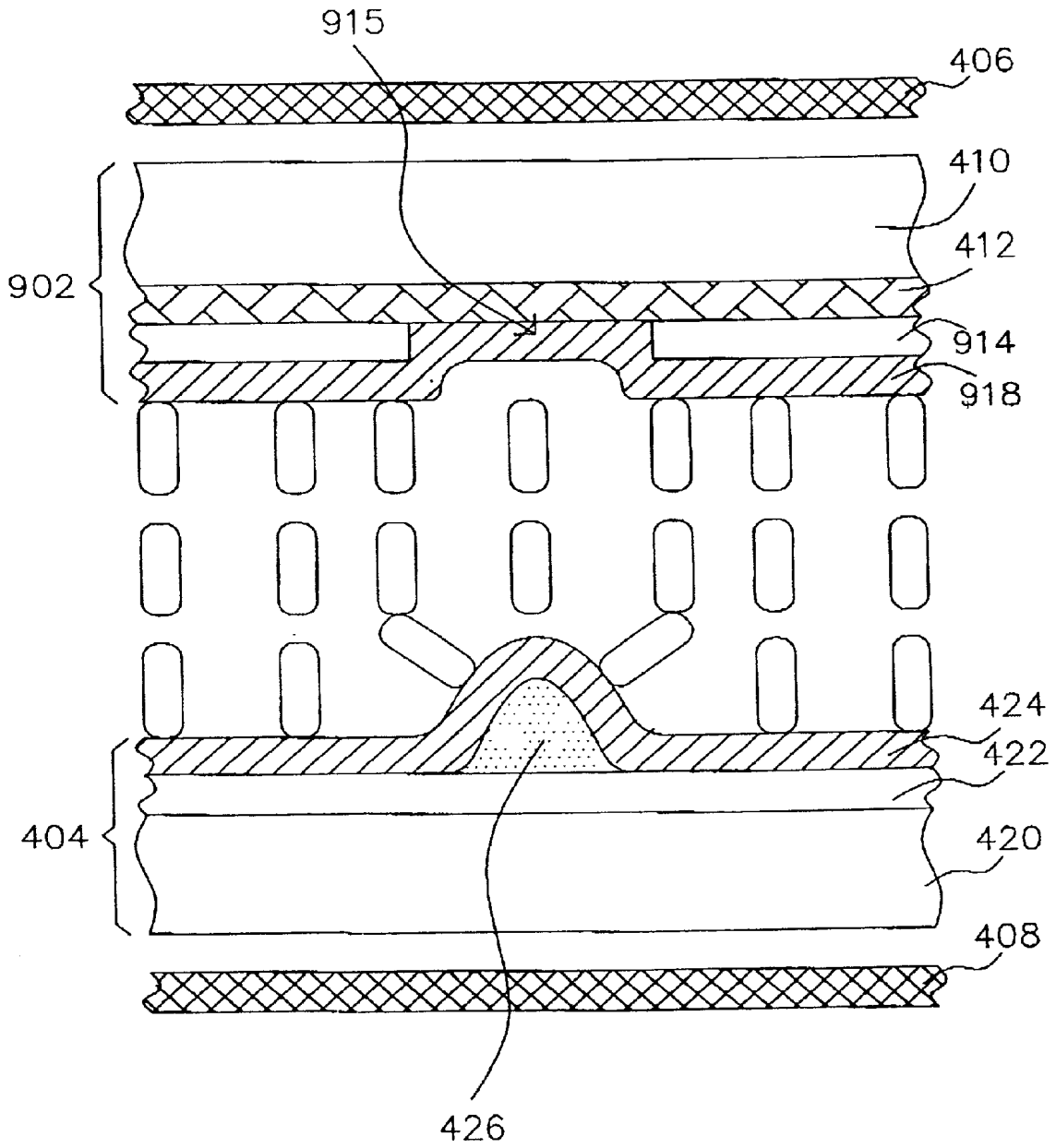

FIG. 9A

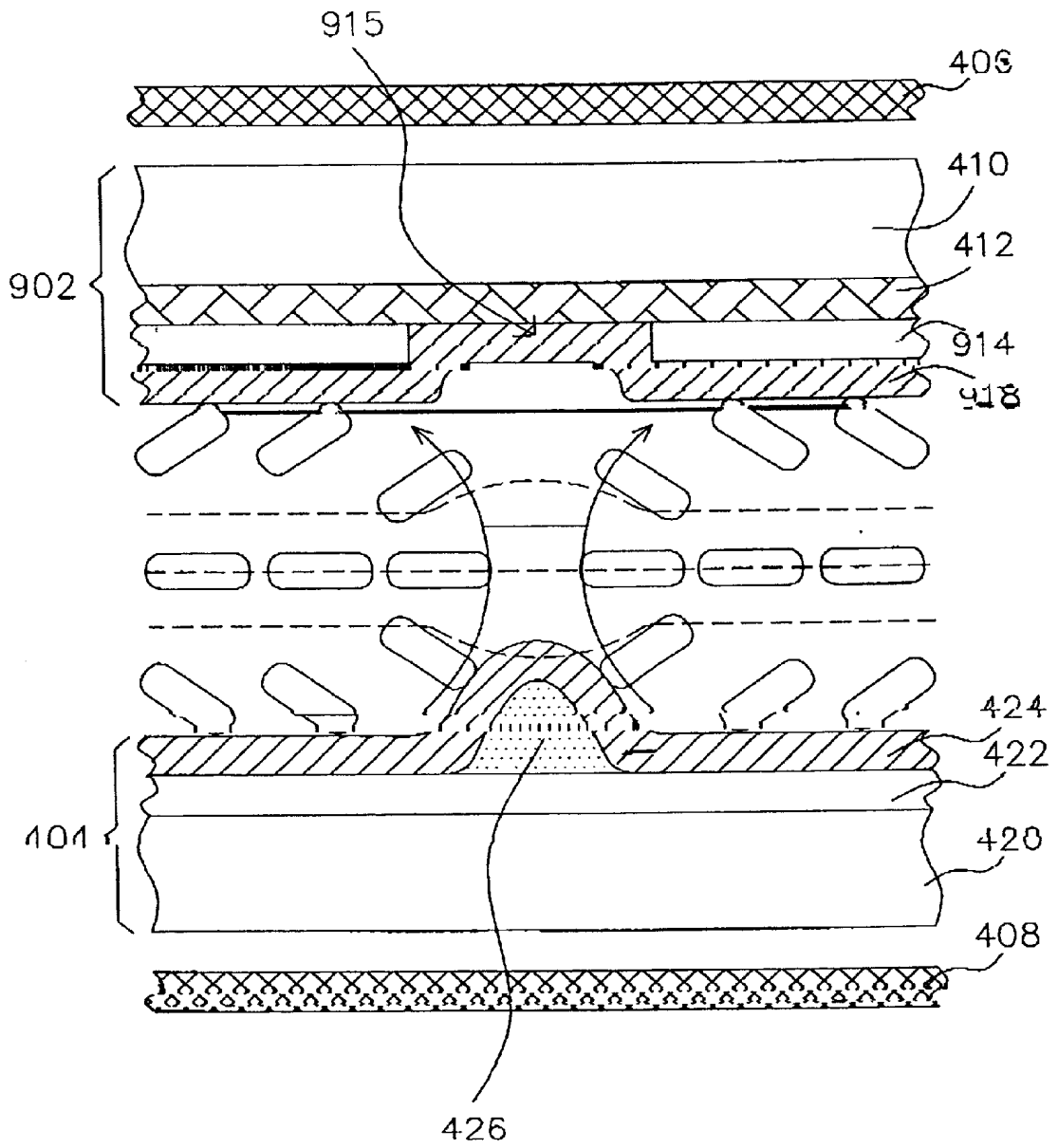

FIG. 9B

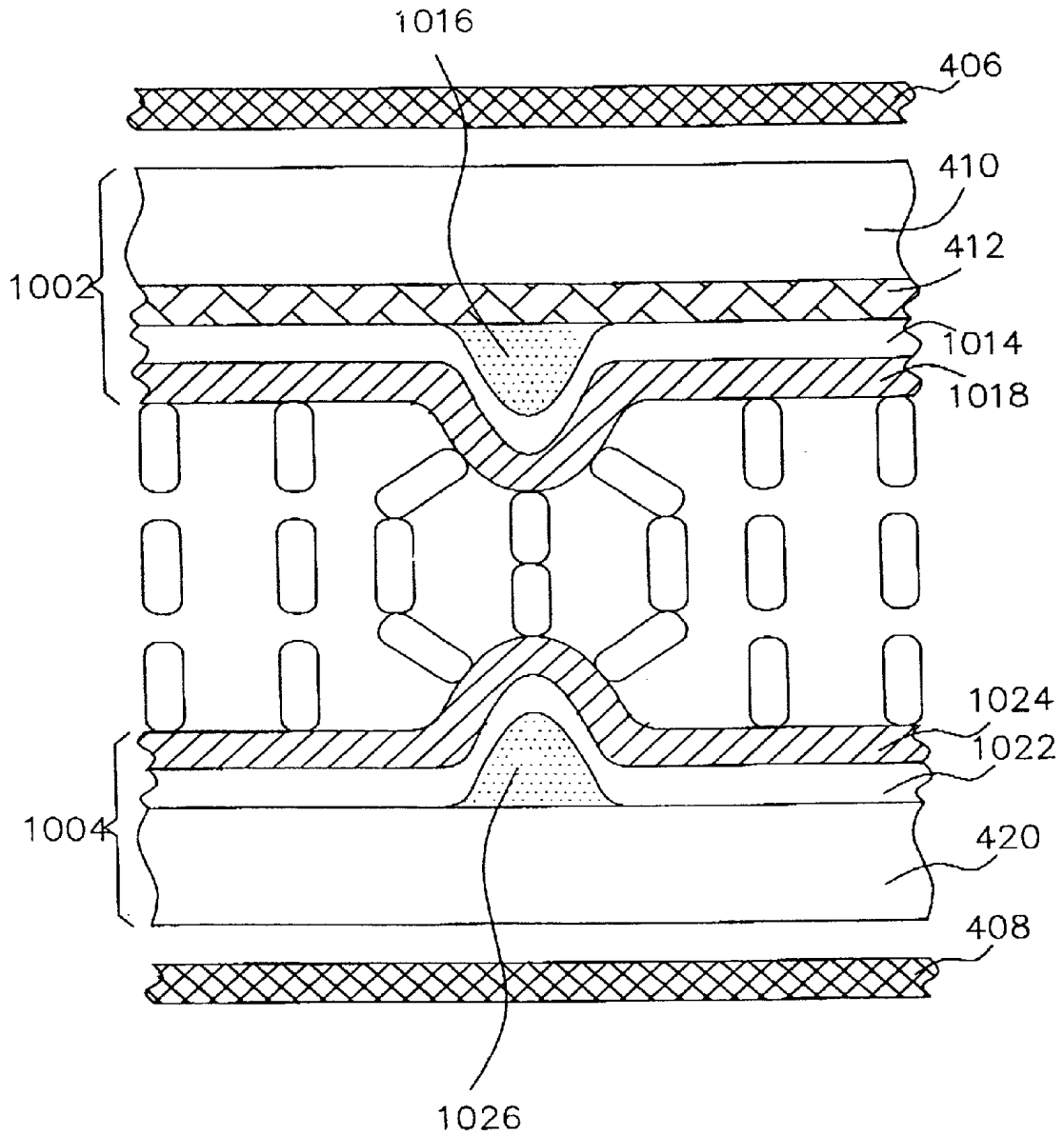

FIG. 10A

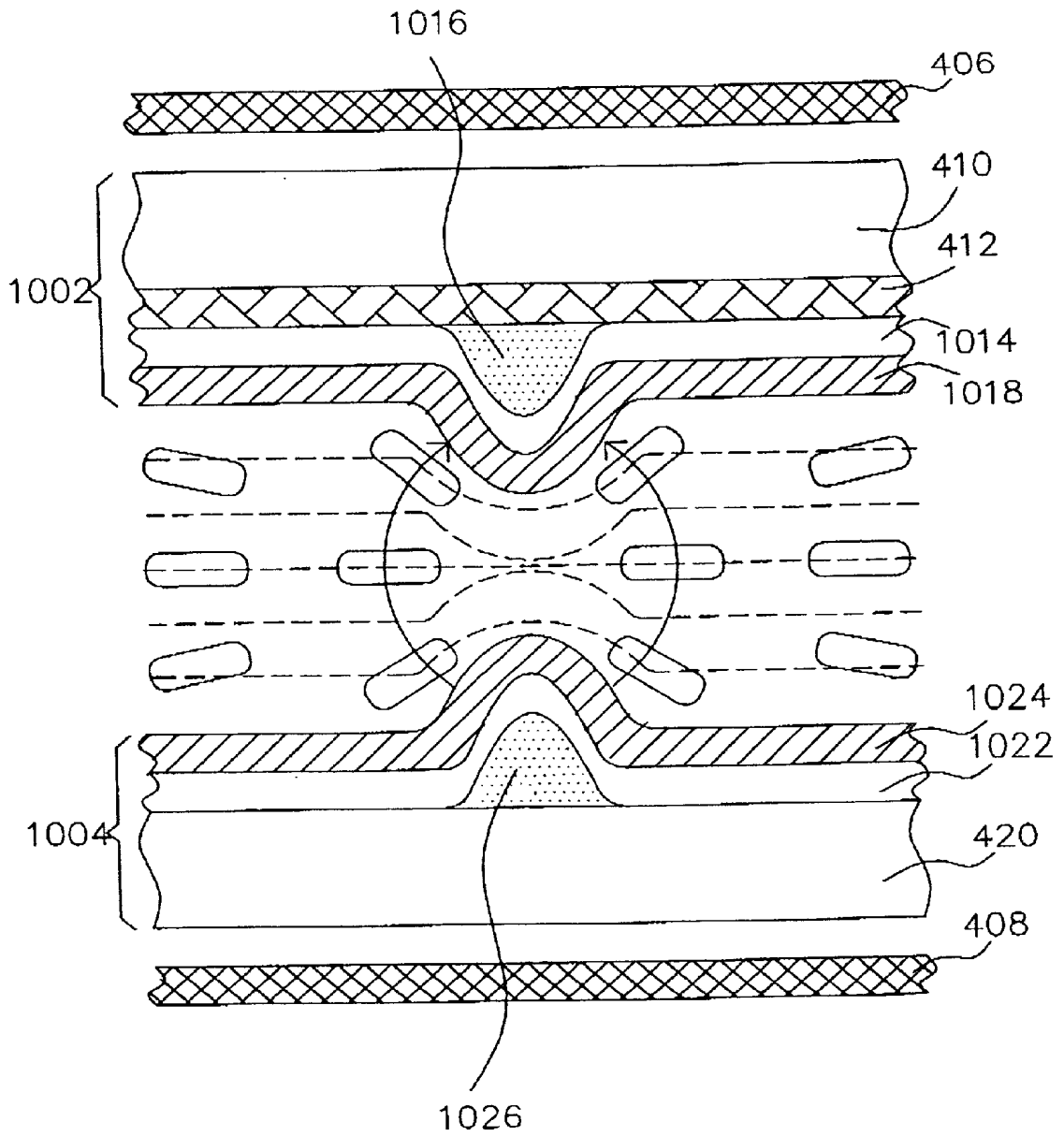

FIG. 10B

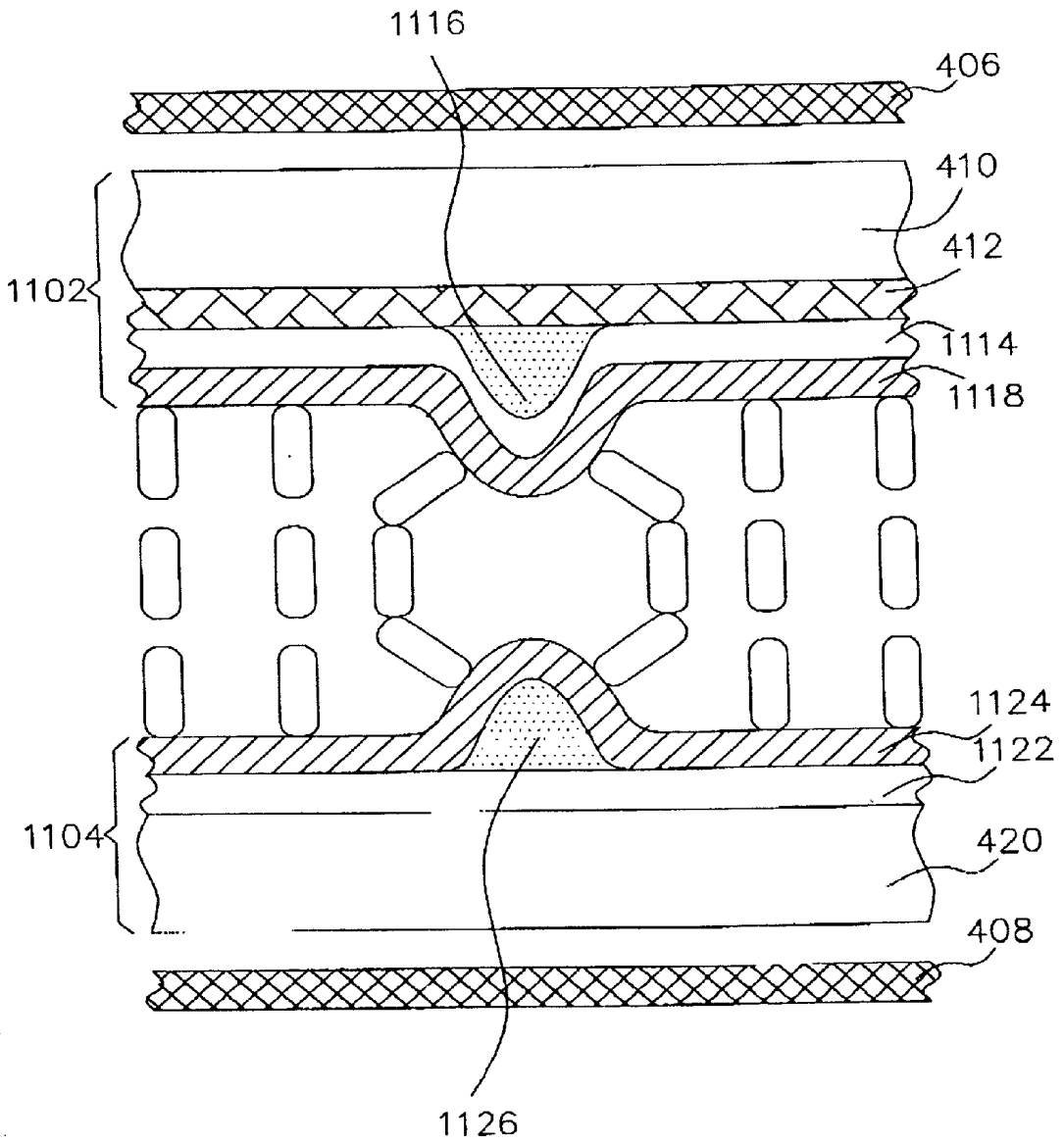

FIG. 11A

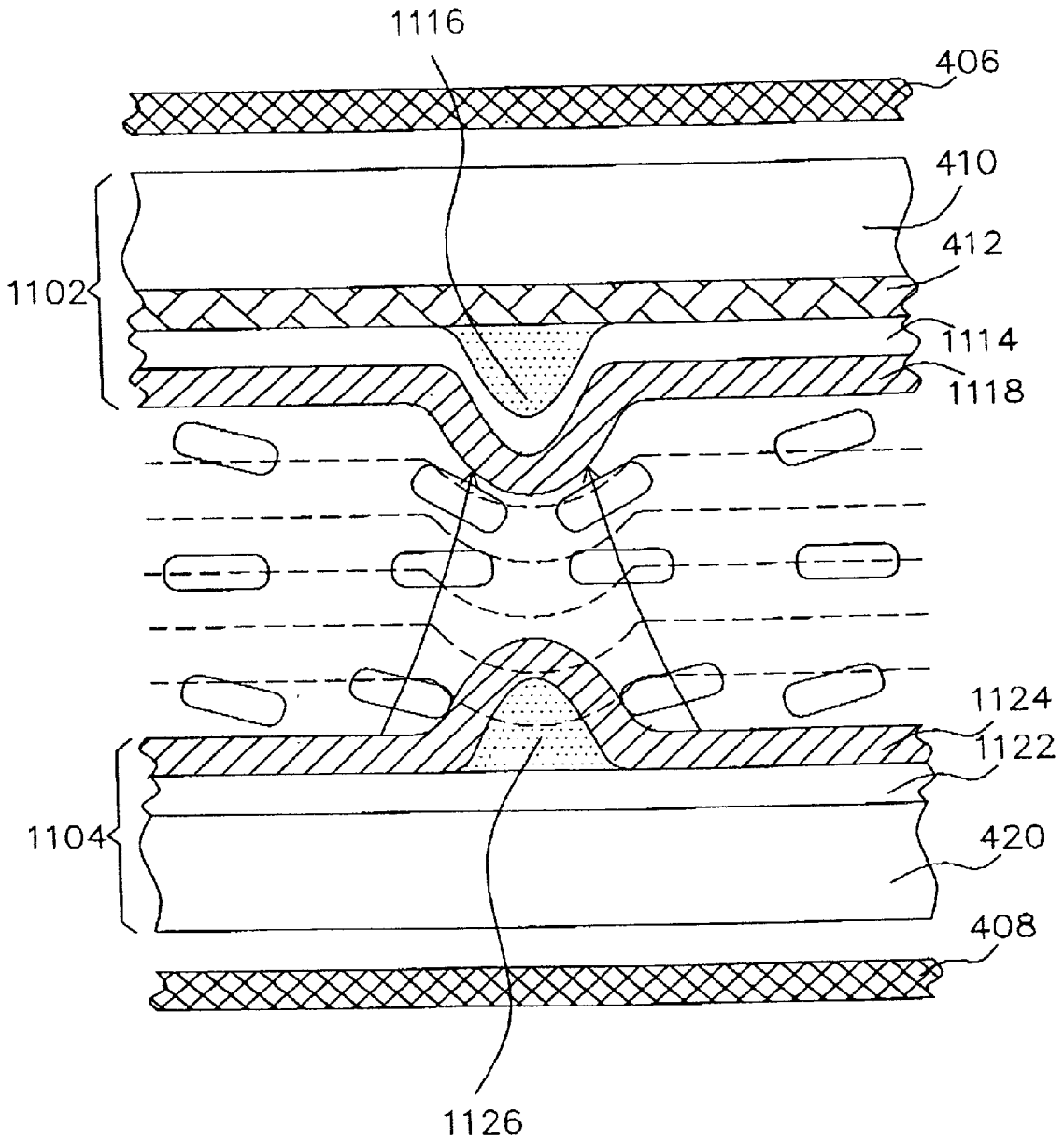

FIG. 11B

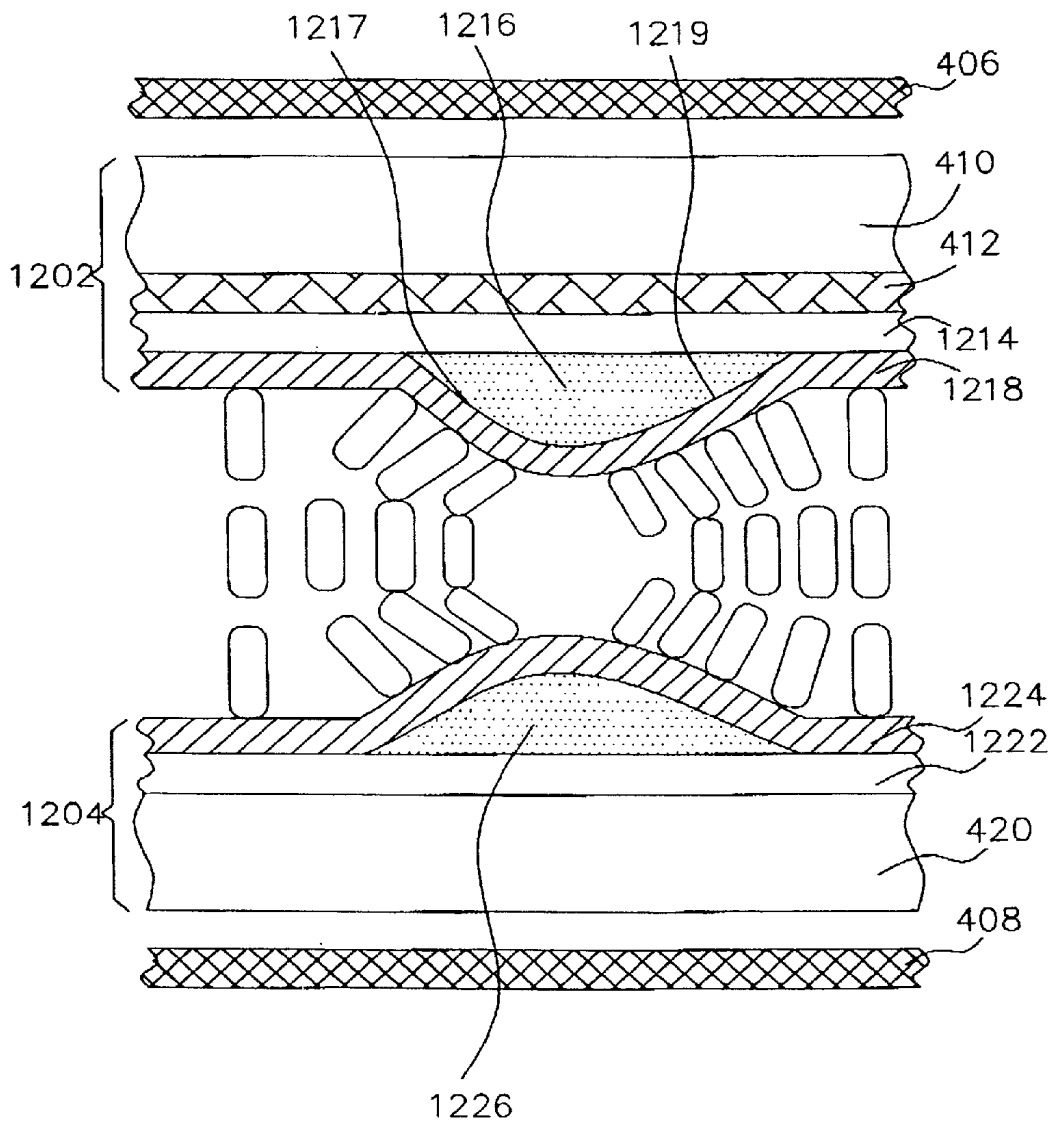

FIG. 12

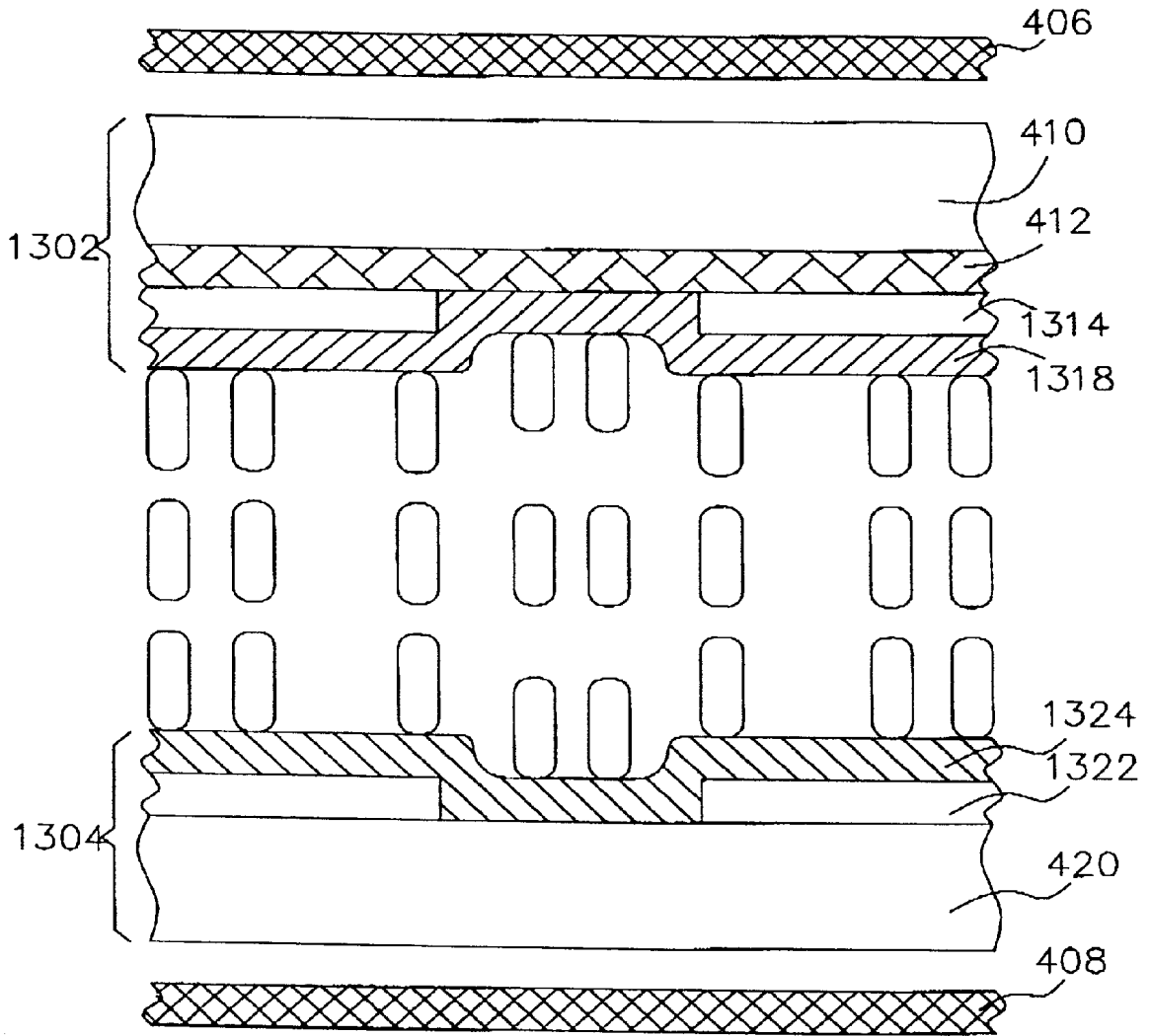

FIG. 13

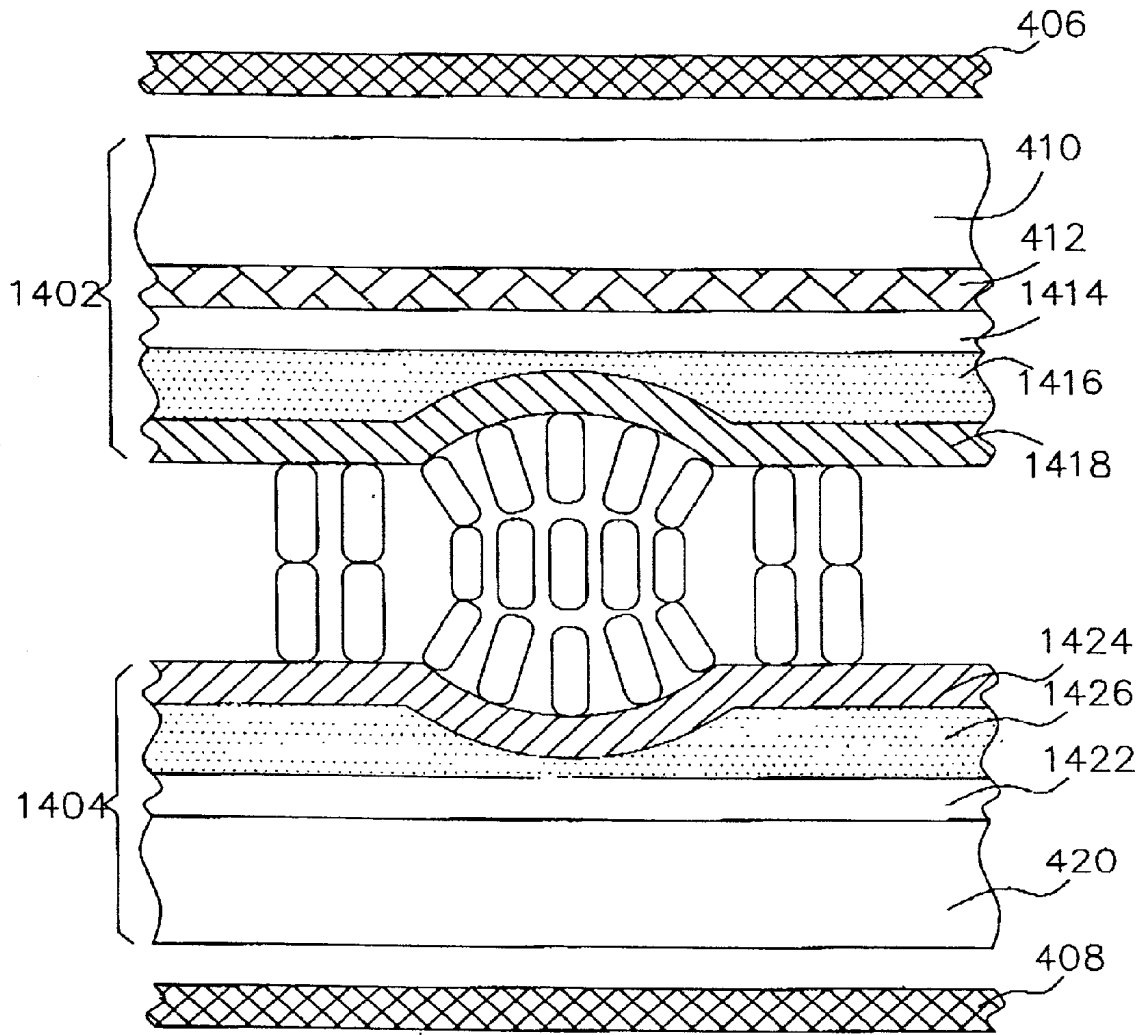

FIG. 14

LIQUID CRYSTAL DISPLAY WITH WIDE VIEWING ANGLE

[0001] This application incorporates by reference Taiwanese application Serial No. 089126649, Filed Dec. 13, 2000.

BACKGROUND OF THE INVENTION

[0002] 1. Field of the Invention

[0003] The present invention generally relates to a liquid crystal display (LCD) with a wide viewing angle, and more particularly to a LCD having a bias instrument for aligning liquid crystal molecules with a negative dielectric constant.

[0004] 2. Description of the Related Art

[0005] Benefited from the advantages of the thinness, lightness and low radiation properties, LCDs (Liquid Crystal Displays) have been widely used in the world. However, the contrast ratio will be decreased as the user sees the display from a larger viewing angle, which causes the viewing angle to be within a very limited range. Therefore, how to increase the viewing angle and improve the property of the LCD has been the critical lesson for the researchers.

[0006] Referring to FIG. 1, it is a sectional view showing the structure of a conventional LCD. The conventional LCD has an upper plate 102 and a lower plate 104. An upper analyzer film 106 is positioned above the upper plate 102 and a lower polarizer film 108 is positioned under the lower plate 104. The polarization direction of the upper analyzer film 106 is perpendicular to that of the lower polarizer film 108. Moreover, the upper plate 102 includes a glass substrate 110, a color filter 112, a transparent electrode 114, and an alignment film 116. The lower plate 104 includes a glass substrate 120, a transparent electrode 122, and an alignment film 124. The liquid crystal layer 118, including a plurality of liquid crystal molecules 118A, is sandwiched between the upper plate 102 and lower plate 104. After a rubbing process, these liquid crystal molecules are aligned on the alignment films 116 or 124.

[0007] When a voltage V_a is supplied between the transparent electrode 114 and transparent electrode 122, the alignment of the liquid crystal molecules in the liquid crystal layer 118 will be changed according to the amount of the voltage V_a . The direction of light will varied because of different alignment directions of the liquid crystal molecules 118A. Under this condition, the transmittance of the light will be changed according to the state of the liquid crystal molecules 118A in the liquid crystal layer 118. Therefore, the various brightness of the LCD, such as white, dark and gray scale, can be controlled by the various voltage applied between the transparent electrodes 114, 112.

[0008] In order to get a wide viewing angle, a LCD using an OCB mode (Optically Compensated Bend mode) has been provided. Referring to FIG. 2, it shows the relation between the applied voltage V_a and the transmittance of the LCD with the OCB mode. As the applied voltage V_a is 0, the transmittance is T_1 . If the applied voltage V_a equals to the threshold voltage V_c , the transmittance will be the maximum value, T_2 . When the applied voltage V_a is V_1 , the transmittance is the minimum value 0.

[0009] In the OCB mode, the dielectric constant difference of the liquid crystal used in the LCD is positive, and the liquid crystal molecules are in a horizontal alignment on the

alignment films 116, 124. The direction of the upper analyzer film 106 is perpendicular to that of the lower polarizer film 108.

[0010] Referring to FIGS. 3A~3C, the arrangement of the liquid crystal molecules in the liquid crystal layer 118 are varied by different voltages V_a applied to the LCD with the OCB mode. In FIGS. 3A, 3B, 3C, the applied voltage V_a is 0, V_c , and V_1 , respectively. The liquid crystal layer 118 comprises a first liquid crystal layer A, a second liquid crystal layer B and a third liquid crystal layer C. The first liquid crystal layer A is contact with the alignment film 116, the second liquid crystal layer B is contact with the alignment film 124, and the third liquid crystal layer C is sandwiched between the first liquid crystal layer A and the second liquid crystal layer B.

[0011] In FIG. 3A, the applied voltage V_a is zero at the initial state, the angle between the first liquid crystal layer A and the alignment film 116 or the second liquid crystal layer B and the alignment film 124 is very small, about 3 to 8 degree. The liquid crystal molecules in the third liquid crystal layer C turn to parallel to the alignment films 116, 124. This is in a "splay alignment" state. At this time, angles are formed between the liquid crystal molecules and both of the upper and lower analyzers 106, 108, so lights can pass the upper analyzer film 106 through the lower polarizer film 108. The LCD is in a white state.

[0012] In FIG. 3B, as the applied voltage V_a is V_c , the angle between the first liquid crystal layer A and the alignment film 116 or between the second liquid crystal layer B and the alignment film 124 is increased. The liquid crystal molecules in the third liquid crystal layer C are almost perpendicular to the alignment films 116, 124. This is in a "bend alignment" state. At this time, the LCD is in the white state and has a maximum brightness.

[0013] In FIG. 3C, as the applied voltage V_a is V_1 , the angle between the first liquid crystal layer A and the alignment film 116 or between the second liquid crystal layer B and the alignment film 124 is increased to a maximum, about 80 degrees or more. The liquid crystal molecules in the third liquid crystal layer C is substantially perpendicular to the alignment films 116, 124. In other words, the aligned direction of all liquid crystal molecules is almost perpendicular to the upper analyzer 106 and lower polarizer 108, so lights can't pass through these polarizers. At this time, the LCD is in a dark state.

[0014] The OCB mode works when the applied voltage V_a between the upper and lower plate 102, 104 is in a range between the threshold voltage V_c and V_1 . The various brightness and the gray scale of the LCD are achieved by various voltage V_a . In the OCB mode, the liquid crystal molecules can be arranged well, the liquid crystal molecules rotate in the same direction, and the friction between the liquid crystal molecules is reduced. Therefore, the LCD with OCB mode has the advantages of fast response and the wide viewing angle. However, it is unstable when the applied voltage is in the range between zero and the threshold voltage V_c . In this unstable stage, the LCD with the OCB mode is non-operated. In order to operate the LCD, the applied voltage should be higher than the threshold voltage V_c . It takes a time to increase the applied voltage V_a from zero to the threshold voltage V_c . In other words, the response time of the LCD with OCB mode is slow and the applied voltage V_a is high.

SUMMARY OF THE INVENTION

[0015] From the above description, the object of the present invention is to provide a LCD having a wide viewing angle. The LCD is in the dark state without applied voltage and in a white state with the applied voltage, such that the contrast ratio of the LCD is increased. A plurality of domains are defined by opposite bias instruments on the upper and lower substrates to achieve the advantages of the wide viewing angle, high contrast ratio and high response speed.

[0016] According to the present invention, a liquid crystal display having a wide viewing angle includes a first substrate, a first electrode, a first bias instrument, a second substrate, a pixel electrode, a second bias instrument and a liquid crystal layer. The first substrate includes a first surface thereon. The first electrode and the first bias instrument having a first inclined plane are formed on the first surface. The second substrate has a second surface, and the first surface of the first substrate is opposed to the second surface of the second substrate. The pixel electrode and the second bias instrument with a second inclined plane are formed on the second substrate. The first bias instrument is opposed to the second bias instrument. The liquid crystal layer is positioned between the first substrate and the second substrate. The liquid crystal layer includes a plurality of liquid crystal molecules with a negative anisotropic dielectric constant. The liquid crystal layer comprises a first liquid crystal molecule in the proximity of the first bias instrument, a second liquid crystal molecule in the proximity of the second bias instrument, and a third liquid crystal molecule between the first and second liquid crystal molecules.

[0017] While no driving voltage is applied between the first electrode and the pixel electrode, (a) the first liquid crystal molecule is perpendicular to the first inclined surface, a first angle is formed between the first substrate and the first liquid crystal molecule, and the first angle is an acute angle, (b) the second liquid crystal molecule is perpendicular to the second inclined surface, a second angle is formed between the first substrate and the second liquid crystal molecule, and the second angle is an obtuse angle, (c) the third liquid crystal molecule is perpendicular to the first substrate, such that the first, second, third liquid crystal molecules are arranged in a similar π shape between the first and second substrates.

[0018] While a driving voltage applied between the first electrode and the pixel electrode, an oblique electric field is formed between the first substrate and the second substrate because of the first bias instrument and the second bias instrument. The first liquid crystal molecule rotates along a first direction, the second liquid crystal molecule rotates along a second direction, and the first direction is contrary to the second direction. Therefore, all liquid crystal molecules are almost parallel to the first substrate because of the oblique electric field.

[0019] In addition, the LCD is in a dark state while no driving voltage is applied between the first electrode and the pixel electrode. The LCD will be in a white state when a driving voltage is applied between the first electrode and the pixel electrode.

[0020] Moreover, a plurality of pixel area are defined between the upper plate and lower plate. Each pixel area is divided to many domains by the first bias instrument and the second bias instrument.

[0021] These advantages of the present invention will become apparent to those skilled in the art upon reading and understanding the following detailed description with reference to the accompanying figures.

BRIEF DESCRIPTION OF THE DRAWINGS

[0022] FIG. 1 is the sectional view showing the structure of a conventional LCD.

[0023] FIG. 2 shows the relation between the applied voltage V_a and the transmittance of the LCD in the OCB mode.

[0024] FIGS. 3A~3C show the arrangement of the liquid crystal molecules in the liquid crystal layer when different voltages V_a are applied on the LCD with the OCB mode.

[0025] FIG. 4 is the cross sectional view of the LCD structure according to the first embodiment of the present invention.

[0026] FIG. 5 shows the relation between the applied voltage V_a and the transmittance of the LCD according to the present invention.

[0027] FIG. 6 is the cross sectional view of the LCD structure according to FIG. 4 when a voltage V_x is applied between the first electrode and the pixel electrode.

[0028] FIG. 7 shows the relation between the liquid crystal molecules and the incident light according to FIG. 6.

[0029] FIGS. 8A~8D are the top views showing the shape of the bump in one pixel area and the arrangement of the liquid crystal molecules according to the present invention.

[0030] FIGS. 9A~9B are the cross sectional views of the LCD according the second embodiment in the present invention.

[0031] FIGS. 10A~10B are the cross sectional views of the LCD according the third embodiment in the present invention.

[0032] FIGS. 11A~11B are the cross sectional views of the LCD according the fourth embodiment in the present invention.

[0033] FIG. 12 is the cross sectional view of the LCD according the fifth embodiment in the present invention.

[0034] FIG. 13 is the cross sectional view of the LCD according the sixth embodiment in the present invention.

[0035] FIG. 14 is the cross sectional view of the LCD according the seventh embodiment in the present invention.

DESCRIPTION OF THE PREFERRED EMBODIMENT

[0036] The LCD (Liquid Crystal Display) in the present invention has the advantages of the VA (vertical alignment) mode and the OCB (Optically Compensated Bend) mode. These advantages include a wide viewing angle, a high contrast ratio, and a high response speed of the liquid crystal molecules. These advantages can be achieved by a lateral oblique electric field formed in the liquid crystal layer, a vertical alignment of the liquid crystal molecules, and a negative difference of the dielectric constant for the liquid crystal molecules.

[0037] First Embodiment:

[0038] Referring to FIG. 4, it is the cross sectional view of the LCD (Liquid Crystal Display) structure according to the present invention's first embodiment. The LCD has an upper plate 402 and a lower plate 404. An upper analyzer film 406 is positioned on the upper plate 402 and a lower polarizer film 408 is positioned under the lower plate 404. The polarization direction of the upper analyzer film 406 is perpendicular to that of the lower polarizer film 408. The upper plate 402 contains a first substrate 410 and the upper plate 402 contains a second substrate 420. The first substrate 410 has a first surface 4101, the second substrate 420 has a second surface 4201, and the first surface 4101 is opposite to the second surface 4201. Moreover, a color filter 412, a first electrode 414, and a first bias instrument 416 are formed on the first substrate 410. In this embodiment, the first bias instrument 416 is a bump 416 formed on the first electrode 414. The bump 416 is a dielectric layer with a low dielectric constant. A vertical alignment film 418 further covers the bump 416 and the first electrode 414.

[0039] A pixel electrode 422 and a second bias instrument 426 are formed on the lower plate 404. In this embodiment, the pixel electrode 422 is formed on the second surface 4201 of the second substrate 420, and the second bias instrument is a bump 426 on the pixel electrode 422. The bump 426 and the pixel electrode 422 are covered by the vertical alignment film 424. The liquid crystal layer 428 is sandwiched between the upper plate 402 and lower plate 404. As shown in FIG. 4, the bump 416 has at least one inclined plane 4161, and the bump 426 has at least one inclined plane 4261. The bump 426 of the second substrate 420 is opposite to the bump 416 of the first substrate 410.

[0040] The liquid crystal layer 428 includes a plural liquid crystal molecules with a negative anisotropic dielectric constant. The liquid crystal layer 428 has a first liquid crystal layer A', a second liquid crystal layer B', and a third liquid crystal layer C'. The first liquid crystal layer A' includes several first liquid crystal molecules, including the first liquid crystal molecules 428A'1 and 428A'2 which are contact with the vertical alignment film 418. The first liquid crystal molecule 428A'1 is in the proximity of the bump 416. The second liquid crystal layer B' contains a plurality of second liquid crystal molecules, such as the liquid crystal molecules 428B'1 and 428B'2 which are contact with the vertical alignment film 424. The second liquid crystal molecule 428B'1 is in the proximity of the bump 426. Furthermore, a plurality of third liquid crystal molecules in the third liquid crystal layer C' are sandwiched between the first liquid crystal layer A' and the second liquid crystal layer B'.

[0041] When no driving voltage is applied between the first electrode 410 and pixel electrode 420, the first liquid crystal molecule 428A'1 is perpendicular to the first inclined surface 4161. A first angle θ_1 , an acute angle, is formed between the first substrate 410 and the first liquid crystal molecule 428A'1. Meanwhile, the second liquid crystal molecule 428B'1 is perpendicular to the second inclined surface 4261. A second angle θ_2 , an obtuse angle, is formed between the first substrate 410 and the second liquid crystal molecule 428B'1. The third liquid crystal molecules 428C'1 is perpendicular to the first substrate 410. Therefore, the first liquid crystal molecule 428A'1, the third liquid crystal molecule 428C'1, and the second liquid crystal molecule

428B'1 are arranged in a similar π shape between the first substrate 410 and the second substrate 420.

[0042] In the present invention, the dielectric constant difference of the liquid crystal molecules in the liquid crystal layer 428 is negative. In other words, the dielectric constant along a direction parallel to the long axis of the liquid crystal molecule is smaller than that perpendicular to the long axis of the liquid crystal molecule. To increase the effect of the present invention, the bumps 416, 426 are made of a low dielectric material, and the difference between the liquid crystal molecules and the bumps should be increased as large as possible.

[0043] At this time, the liquid crystal molecules are in a vertical arrangement, in other words, are perpendicular to the upper analyzer film 406 and lower polarizer film 408. Therefore, no light (not shown in Figure) can pass through the upper analyzer film 406 and the lower polarizer film 408 as no driving voltage is applied. The LCD is in a better dark state.

[0044] Referring to FIG. 5, it shows the relation between the applied voltage V_a and the transmittance of the LCD. As the voltage V_a between the first electrode 414 and the pixel electrode 422 is 0, the LCD is in the dark state, and the transmittance is zero. If the voltage V_a applied between the first electrode 414 and the pixel electrode 422 is V_x , the transmittance will be at a maximum T_3 . As shown in FIG. 5, the transmittance will be increased as the applied voltage V_a becomes larger. Hence, the gray scale of the LCD display can be accomplished by adjusting the applied voltage properly.

[0045] Referring to FIG. 6, it is the cross sectional view of the LCD (Liquid Crystal Display) structure according to FIG. 4 when a voltage V_x is applied across the first electrode and the pixel electrode. When the voltage V_x is applied between the first electrode 414 and the pixel electrode 422, the orientation of the liquid crystal layer 428 will be changed according to the voltage V_x . In FIG. 6, the dash line is the equipotential line of an electric field formed between the first electrode 414 and the pixel electrode 422 while the voltage V_x is applied. The arrow indicates the direction of the electric field. Because the dielectric constant is negative, the liquid crystal molecules in the third liquid crystal layer C' will rotate along the electric field, and the long axis of each liquid crystal molecule will be vertical to the electric field. In addition, the liquid crystal molecules 428A'1 in the first liquid crystal A' will rotate until the long axis of the liquid crystal molecules 428A'1 is perpendicular to the electric field after the voltage V_x applied. Because the liquid crystal molecules are very close to each other, the liquid crystal molecules 428A'1 will induce the neighboring liquid crystal molecules in the first liquid crystal layer A', such as the liquid crystal molecule 428A'2, to rotate in the similar direction. According to the same reason, all of the liquid crystal molecules in the second liquid crystal layer B', such as the liquid crystal molecule 428B'2, will rotate in the similar direction of the liquid crystal molecule 428B'1.

[0046] In other words, a driving electric field 43 with oblique shape is formed between the first substrate 410 and the second substrate 420 because of the bumps 416 and 426 when the voltage is applied across the first electrode 414 and the pixel electrode 422. Therefore, the first liquid crystal molecule 428A'1 will rotate along the first direction 45, and

the second liquid crystal molecule **428B'1** will rotate along the second direction **49**. The orientation of the first direction **45** is opposite to the second direction **49**, all of the liquid crystal molecules **428A'1**, **428B'1** and **428C'1** will rotate to parallel to the first substrate **410**.

[0047] In this time, most of the liquid crystal molecules are parallel to the first electrode **414** and the pixel electrode **422**, and angles are formed among the liquid crystal molecules and the upper analyzer film **406**, the lower polarizer film **408**. After the driving voltage is applied, the light (not shown in Figure) can pass through the lower polarizer film **408** and the upper analyzer film **406**. Therefore, the LCD is in a white state.

[0048] Compared with the present invention and the conventional LCD, the arrangements of the liquid crystal molecules in **FIG. 3C** and that in **FIG. 4** are similar when the LCD is in the dark state. The liquid crystal molecules are arranged in a π shape. In addition, the arrangements of the liquid crystal molecules in **FIG. 3A** are similar with those in **FIG. 6** when the LCD is in the white state. The long axis of the liquid crystal molecules is parallel to the pixel electrode. However, one voltage is needed in **FIG. 3C** but no voltage is needed in **FIG. 4** when the LCD is in the dark state. Further, no voltage is needed in **FIG. 3A** but one voltage is needed in **FIG. 6** when the LCD is in the write state. The operation in the present invention is counter to that of the OCB mode in the conventional LCD. Therefore, the LCD in the present invention can be deemed as a LCD having a reverse OCB mode.

[0049] Referring to **FIG. 7**, it shows the relation between the liquid crystal molecules and the incident light according to **FIG. 6**. The arrangement of the liquid crystal molecules in the first liquid crystal layer A' is symmetrical to that of the liquid crystal molecules in the second liquid crystal layer B'. Therefore, the effects to these liquid crystal molecules are the same as the light L1 and light L2 pass the liquid crystal layer **428**, respectively. Accordingly, when watching from the right side and the left side of the LCD, the brightness shown on the display are the same, and the viewing angle is increased in the present invention.

[0050] After the voltage is applied, the arrangement of the liquid crystal molecules in **FIG. 4** is changed to that in **FIG. 6**, the rotating directions of liquid crystal molecules in the upper lower liquid crystal layer is inverse to that in the lower liquid crystal layer. One rotates clockwise and the other rotates counterclockwise. Therefore, the friction between these liquid crystal molecules will be small and the response speed of the liquid crystal molecules will be increased. In the conventional LCD, including TN (Twisted Nematic mode) type or VA (Vertical alignment mode) type, all liquid crystal molecules rotate toward the same direction, the clockwise or the counter clockwise. The frictions between the liquid crystal molecules in the upper and lower layer are large, and the response speed is slow.

[0051] Moreover, as shown in **FIG. 6**, the curvature of the electric field near the bump **416** and **426** is large, the strength for rotating the liquid crystal molecules is enhanced, and the response speed of the liquid crystal molecules is increased.

[0052] Please referring to **FIGS. 8A~8D** which are top views showing the shape of the bump in one pixel area and the arrangement of the liquid crystal molecules according to

the present invention. The pixel area means a space between the first and second substrates **410**, **420** and corresponded to the pixel electrode. The bump **416** overlaps the bump **426** and is represented in **FIGS. 8A~8D** by the white region. Referring to **FIG. 4** at the same time, the upper plate **402** and the lower plate **404**, extending along the XY plane, include a plurality of pixel areas thereon. In each pixel area, the bump **416** and bump **426** of the first and second bias instrument divide each pixel area to some domains. After the voltage applied, the liquid crystal molecules in the pixel area will lean toward different directions, and different lean directions of the liquid crystal molecules mean different display areas. **FIGS. 8A, 8B** and **8D** show the LCD having two display areas, and **FIG. 8C** shows the LCD having four display areas. The viewing angle of the LCD can be improved by using different display area or increasing the number of the display area.

[0053] As shown in **FIGS. 8A~8D**, the direction A indicates the polarization direction of the upper analyzer film **406** and the direction P indicates the polarization direction of the lower polarizer film **408**. The polarization directions of upper analyzer film **406** and lower polarizer film **408** can be exchanged. The bump in **FIG. 8A** is formed along the diagonal of a pixel area, the bump of **FIG. 8C** is formed in a shape of a cross, and the bump in **FIG. 8D** is formed as a H shape. However, the embodiments in the present invention will not be the limitation of the scope. Any method to form different display areas by bumps will fall in the scope of the present invention.

[0054] Second Embodiment

[0055] Bumps are used to form an oblique electric field in **FIG. 4** and **FIG. 6**. However, the scope of the present invention includes any method to form an oblique electric field between the first electrode **414** and the pixel electrode **426**.

[0056] Referring to **FIGS. 9A and 9B**, they are the cross sectional view of the LCD according the second embodiment in the present invention. In **FIGS. 9A~9B**, the same numbers are used to indicate the identical parts as shown in **FIG. 4**. No voltage is applied in **FIG. 9A** and at least one voltage is applied in **FIG. 9B**. In the upper plate **902**, a slit **915** is formed on the first electrode **914**, and a vertical alignment film **918** covers the slit **915** and the first electrode **914**. The structure of the lower plate **404** is the same as the first embodiment in **FIG. 4**. As shown in **FIG. 9B**, when a voltage is applied, a curved electric field is produced by the opposing bump **426** and slit **915**, and the purpose of the present invention is accomplished.

[0057] Third Embodiment

[0058] Referring to **FIGS. 10A and 10B**, they are the cross sectional view of the LCD according the third embodiment in the present invention. In **FIGS. 10A~10B**, the same numbers are used to indicate the identical parts as shown in **FIG. 4**. **FIGS. 10A and 10B** show the arrangement of the liquid crystal molecules without and with a voltage applied in the LCD. In the upper plate **1002**, a bump **1016** is formed on the color filter **412**, a first electrode **1014** is formed on the color filter **412**, and a vertical alignment film **1018** further covers the first electrode **1014**. In the lower plate **1004**, the bump **1026** formed on the second substrate **420** is opposite to the bump **1016**, a pixel electrode **1022** is further formed

on the bump **1026**. There's a difference between the first embodiment and the third embodiment. For the first embodiment, the bump is formed on the electrode. However, for the third embodiment, the bumps **1016**, **1026** are formed below the first electrode **1014** and the pixel electrode **1022**, respectively. As shown in **FIG. 10B**, a curved electric field is produced by the bump **1016** and **1026**, and the purpose of the present invention is accomplished.

[**0059**] Fourth Embodiment

[**0060**] Referring to **FIGS. 11A and 11B**, they are the cross sectional view of the LCD according the fourth embodiment in the present invention. In **FIGS. 11A~11B**, the same numbers are used to indicate the identical parts as shown in **FIG. 4**. **FIGS. 11A and 11B** show the arrangement of the liquid crystal molecules without and with an voltage applied in the LCD. In the upper plate **1102**, a bump **1116** is formed on the color filter **412**, a first electrode **1114** is formed on the color filter **412**, and a vertical alignment film **1118** covers the first electrode **1114**. In the lowerplate **1104**, the bump **1126** opposed to the bump **1116** is formed on the pixel electrode **1122**, and a vertical alignment film **1124** is further formed on the pixel electrode **1122**. The design of the fourth embodiment is different from that of the first or third embodiment. In the fourth embodiment, the bump **1116** regarded as the first bias instrument is positioned under the first electrode **1114**, and the bump **1126** regarded as the second bias instrument is formed on the pixel electrode **1022**. As shown in **FIG. 11B**, an oblique electric field is produced by the bump **1116** and **1126** after a voltage is applied, and the purpose of the present invention can be come true.

[**0061**] Fifth Embodiment

[**0062**] Referring to **FIG. 12**, it is the cross sectional view of the LCD according the fifth embodiment in the present invention. In **FIG. 12**, the same numbers are used to indicate the identical parts as shown in **FIG. 4**. No voltage is applied in **FIG. 12**. A bump **1216** is formed on the first electrode **1214**, a bump **1226** is formed on the pixel electrode **1222**. The bump **1226** is opposite to the bump **1216**. Moreover, the bump **1216** regarded as the first bias instrument has two inclined planes **1217**, **1219** and the slope of these two inclined planes are different. The bump **1226** of the second bias instrument also has two inclined planes with different slope. Therefore, by the different slopes of these two bumps **1216** and **1226**, the liquid crystal molecules position by the two sides of each bump will be aligned to different direction, and different display areas will be formed after a voltage is applied.

[**0063**] Sixth Embodiment

[**0064**] **FIG. 13** is the cross sectional view of the LCD according the sixth embodiment in the present invention. In **FIG. 13**, the same numbers are used to indicate the identical parts as shown in **FIG. 4**. No voltage is applied in **FIG. 13**. Two opposing slits are formed on the first electrode **1314** and the pixel electrode **1322**, the vertical alignment film **1318** and **1324** cover the first electrode **1314** and the pixel electrode **1322**. Therefore, an oblique electric field is formed because of the slits of the first electrode **1314** and pixel electrode **1322** after a voltage is applied, and the purpose of the present invention is accomplished.

[**0065**] Seventh Embodiment

[**0066**] **FIG. 14** is the cross sectional view of the LCD according the seventh embodiment in the present invention. In **FIG. 14**, the same numbers are used to indicate the identical parts as shown in **FIG. 4**. No voltage is applied in **FIG. 14**. Two opposing recessions of the dielectric layer **1416** and **1426** are formed. The dielectric layer **1416** is positioned between the first electrode **1414** and vertical alignment film **1418**. The dielectric layer **1426** is positioned between the pixel electrode **1422** and the vertical alignment electrode **1424**. Therefore, an oblique electric field is formed because of the recessions of the dielectric layer **1416** and **1426** after a voltage is applied, and the purpose of the present invention is accomplished

[**0067**] In the present invention, the LCD with a wide viewing angle includes the advantages of the VA mode LCD and the OCB mode LCD. These advantages include a wide viewing angle, a fast response speed, a high contrast ratio, and a perfect dark state without applied voltage.

[**0068**] Once given the above disclosure, many other features, modifications, and improvements will become apparent to the skilled artisan. Such other features, modifications, and improvements are, therefore, considered to be a part of this invention, the scope of which is to be determined by the following claims.

What is claimed is:

1. A Liquid Crystal Display (LCD) with a wide viewing angle, the LCD comprising:

- a first substrate including a first surface thereon;
- a first electrode and a first bias instrument formed on said first surface of said first substrate, and said first bias instrument having a first inclined plane;
- a second substrate including a second surface thereon, and said first surface being opposed to said second surface;
- a pixel electrode and a second bias instrument formed on said second surface of said second substrate, said second bias instrument having a second inclined plane on said second surface, and said first bias instrument opposing to said second bias instrument; and
- a liquid crystal layer formed between said first substrate and said second substrate, said liquid crystal layer having a plurality of liquid crystal molecules with a negative anisotropic dielectric constant, said liquid crystal layer comprising a first liquid crystal molecule in the proximity of said first bias instrument, a second liquid crystal molecule in the proximity of said second bias instrument, and a third liquid crystal molecule between said first and second liquid crystal molecules;

wherein as no driving voltage is applied between said first electrode and said pixel electrode, (a) said first liquid crystal molecule is perpendicular to the first inclined surface, a first angle is formed between said first substrate and said first liquid crystal molecule, and the first angle is an acute angle, (b) said second liquid crystal molecule is perpendicular to the second inclined surface, a second angle is formed between said first substrate and said second liquid crystal molecule, and the second angle is an obtuse angle, (c) said third liquid crystal molecule is perpendicular to the first substrate, therefore, said first, second and third liquid crystal molecules are arranged in a similar π shape between said first substrate and said second substrate;

while the driving voltage is applied between said first electrode and said pixel electrode, an oblique electric field is formed between said first substrate and said second substrate because of said first bias instrument and said second bias instrument, said first liquid crystal molecule rotates along a first direction, said second liquid crystal molecule rotates along a second direction, said first direction is contrary to said second direction, so that said plurality of liquid crystal molecules of the liquid crystal layer are substantially parallel to said first substrate because of said oblique electric field.

2. The liquid crystal display of claim 1, wherein said first bias instrument is a first bump formed on said first electrode, said second bias instrument is a second bump formed on said pixel electrode, and said second bump is positioned below said first bump.

3. The liquid crystal display of claim 2, wherein said first bump and said second bump are made of a low dielectric constant material.

4. The liquid crystal display of claim 2, wherein said first bump further comprises a third inclined plane and said second bump further comprises a fourth inclined plane, said first, second, third, and fourth inclined planes have a first, second, third, fourth slopes, said first slope is different from said third slope, and said second slope is different from said fourth slope.

5. The liquid crystal display of claim 1, wherein said first bias instrument is a first bump formed on said first substrate and covered by said first electrode, said second bias instrument is a second bump formed on said pixel electrode, and said first bump and said second bump are made of a low dielectric constant material.

6. The liquid crystal display of claim 1, wherein said first bias instrument is a first bump formed on said first substrate and covered by said first electrode, said second bias instrument is a second bump formed on said second substrate and covered by said pixel electrode, and said first bump and said second bump are made of a low dielectric constant material.

7. The liquid crystal display of claim 1, wherein said first substrate further comprises a first dielectric layer and said second substrate further comprises a second dielectric layer, said first bias instrument is a first recess in said first dielectric layer and said second bias instrument is a second recess in said second dielectric layer, said second recess is opposed to said first recess, said first dielectric layer is formed above said first electrode, and said second dielectric layer is formed above said pixel electrode.

8. The liquid crystal display of claim 1, wherein a pixel area is defined as the space between said first substrate and said second substrate, and said first bias instrument and said second bias instrument divide said pixel area to a plurality of domains.

9. The liquid crystal display of claim 8, wherein said first bias instrument and said second bias instrument are formed along the diagonals of said pixel area.

10. The liquid crystal display of claim 8, wherein said first bias instrument and said second bias instrument are in an L shape within said pixel area.

11. The liquid crystal display of claim 8, wherein said first bias instrument and said second bias instrument form a cross shape in said pixel area.

12. The liquid crystal display of claim 8, wherein said first bias instrument and said second bias instrument form a H shape in said pixel area.

13. A wide viewing angle LCD (Liquid Crystal Display) comprising:

a first substrate including a first surface thereon;

a first electrode and a first bias instrument formed on said first surface of said first substrate;

a second substrate including a second surface thereon, and said second surface being opposed to said first surface;

a pixel electrode and a second bias instrument formed on said second surface of said second substrate, said second bias instrument being opposed to said first bias instrument; and

a liquid crystal layer formed between said first substrate and said second substrate, said liquid crystal layer having a plurality of liquid crystal molecules with a negative anisotropic dielectric constant, said liquid crystal layer comprising a first liquid crystal molecule in the proximity of said first bias instrument, a second liquid crystal molecule in the proximity of said second bias instrument, and a third liquid crystal molecule between said first and second liquid crystal molecules;

while no driving voltage being applied between said first electrode and said pixel electrode, said first, third, and second liquid crystal molecules being arranged in a similar π shape between said first substrate and said second substrate because (a) said first liquid crystal molecule being perpendicular to the first bias instrument for forming a third angle between said first substrate and said first liquid crystal molecule, (b) said second liquid crystal molecule being perpendicular to the second bias instrument for forming a fourth angle between said first substrate and said second liquid crystal molecule, and said fourth angle being an obtuse angle, and (c) said third liquid crystal molecule being perpendicular to said first substrate;

while a driving voltage being applied between said first electrode and said pixel electrode, an oblique electric driving field being formed between said first substrate and said second substrate because of said first bias instrument and said second bias instrument, said first liquid crystal molecules rotating along a first direction, said second liquid crystal molecule rotating along a second direction different from said first direction, so that all of said first, second, and third liquid crystal molecules being arranged substantially parallel to said first substrate.

14. The liquid crystal display of claim 13, wherein said first bias instrument is a first slit of said first electrode, and said second bias instrument is a third bump formed on said pixel electrode and made of a low dielectric constant material.

15. The liquid crystal display of claim 13, wherein said first bias instrument is a first slit of said first electrode, and said second bias instrument is a second slit of said pixel electrode.

专利名称(译)	具有宽视角的液晶显示器		
公开(公告)号	US20020071081A1	公开(公告)日	2002-06-13
申请号	US10/013515	申请日	2001-12-13
[标]申请(专利权)人(译)	程欣AN		
申请(专利权)人(译)	程HSIN-AN		
当前申请(专利权)人(译)	程HSIN-AN		
[标]发明人	CHENG HSIN AN		
发明人	CHENG, HSIN-AN		
IPC分类号	G02F1/1333 G02F1/139 G02F1/1343		
CPC分类号	G02F1/133707 G02F2001/133776 G02F1/1395		
优先权	089126649 2000-12-13 TW		
其他公开文献	US6753551		
外部链接	Espacenet USPTO		

摘要(译)

公开了一种液晶显示器 (LCD)，其具有倾斜电场，同时在LCD的上板和下板之间施加电压。LCD包括上板的第一偏置仪器和下板的第二偏置仪器。由于上板和下板之间没有电压，第一和第二偏置仪器附近的液晶分子垂直于上板和下板。施加电压后，这些偏置仪器产生倾斜电场。然后，由于倾斜的电场，液晶分子旋转以平行于上板和下板。第一和第二偏置仪器是由介电材料或电极狭缝制成的凸块。

