



US008416164B2

(12) **United States Patent**
Hwang et al.

(10) **Patent No.:** **US 8,416,164 B2**
(45) **Date of Patent:** **Apr. 9, 2013**

(54) **LIQUID CRYSTAL DISPLAY DEVICE**
(75) Inventors: **Kwang Hee Hwang**, Daegu-si (KR);
Chan Won Lee, Daejeon-si (KR); **Sung Hyun Cho**, Seoul (KR)

2002/0044246 A1 * 4/2002 Moon et al. 349/141
2002/0093616 A1 * 7/2002 Park et al. 349/149
2005/0139837 A1 6/2005 Lee et al.
2005/0156840 A1 7/2005 Kim et al.

(73) Assignee: **LG Display Co., Ltd.**, Seoul (KR)
(*) Notice: Subject to any disclaimer, the term of this patent is extended or adjusted under 35 U.S.C. 154(b) by 1160 days.

FOREIGN PATENT DOCUMENTS

EP 1 136 873 A2 9/2001
JP 05-210121 8/1993
JP 06-035002 2/1994
JP 07-218896 8/1995
JP 11-133379 5/1999
JP 2002-202493 7/2002
JP 2002-311451 10/2002
JP 2004-037956 2/2004
KR 10-2004-0061505 7/2004

(21) Appl. No.: **11/453,923**
(22) Filed: **Jun. 16, 2006**

* cited by examiner

(65) **Prior Publication Data**
US 2007/0152943 A1 Jul. 5, 2007

Primary Examiner — Sumati Lefkowitz
Assistant Examiner — Jonathan Horner
(74) *Attorney, Agent, or Firm* — McKenna Long & Aldridge LLP

(30) **Foreign Application Priority Data**
Dec. 29, 2005 (KR) 10-2005-0132909

(57) **ABSTRACT**

(51) **Int. Cl.**
G09G 3/36 (2006.01)
G02F 1/1343 (2006.01)
(52) **U.S. Cl.** **345/87; 345/98; 345/103; 349/147; 349/148**
(58) **Field of Classification Search** 345/98, 345/87, 103; 349/143, 147-452
See application file for complete search history.

A liquid crystal display device is provided. The liquid crystal display device includes: a lower substrate having a first and a second common voltage supplying line, pixel regions defined by a plurality of gate lines and a plurality of data lines and arranged in a matrix, and a plurality of common lines electrically connected to the second common voltage supplying line and arranged to be parallel to each of the gate lines; an upper substrate disposed to face the lower substrate and having a common electrode electrically connected to the first common voltage supplying line; a dot for electrically connecting the first common voltage supplying line and the common electrode; and a common voltage generator for generating a first and a second common voltage for independently supplying the first and the second common voltage to the first and the second common voltage supplying line.

(56) **References Cited**

31 Claims, 3 Drawing Sheets

U.S. PATENT DOCUMENTS

5,774,099 A * 6/1998 Iwasaki et al. 345/87
5,831,709 A * 11/1998 Song 349/149
6,219,124 B1 * 4/2001 Lee et al. 349/147
6,229,510 B1 * 5/2001 Kim et al. 345/87
6,262,702 B1 * 7/2001 Murade 345/87
6,392,626 B1 5/2002 Moon

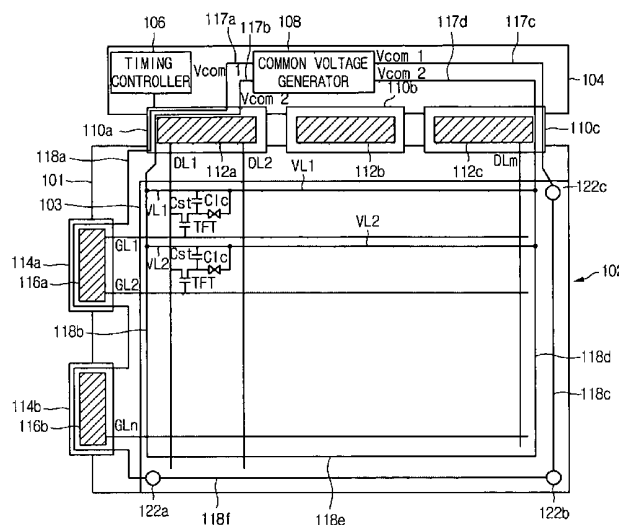

Fig.1 (Related Art)

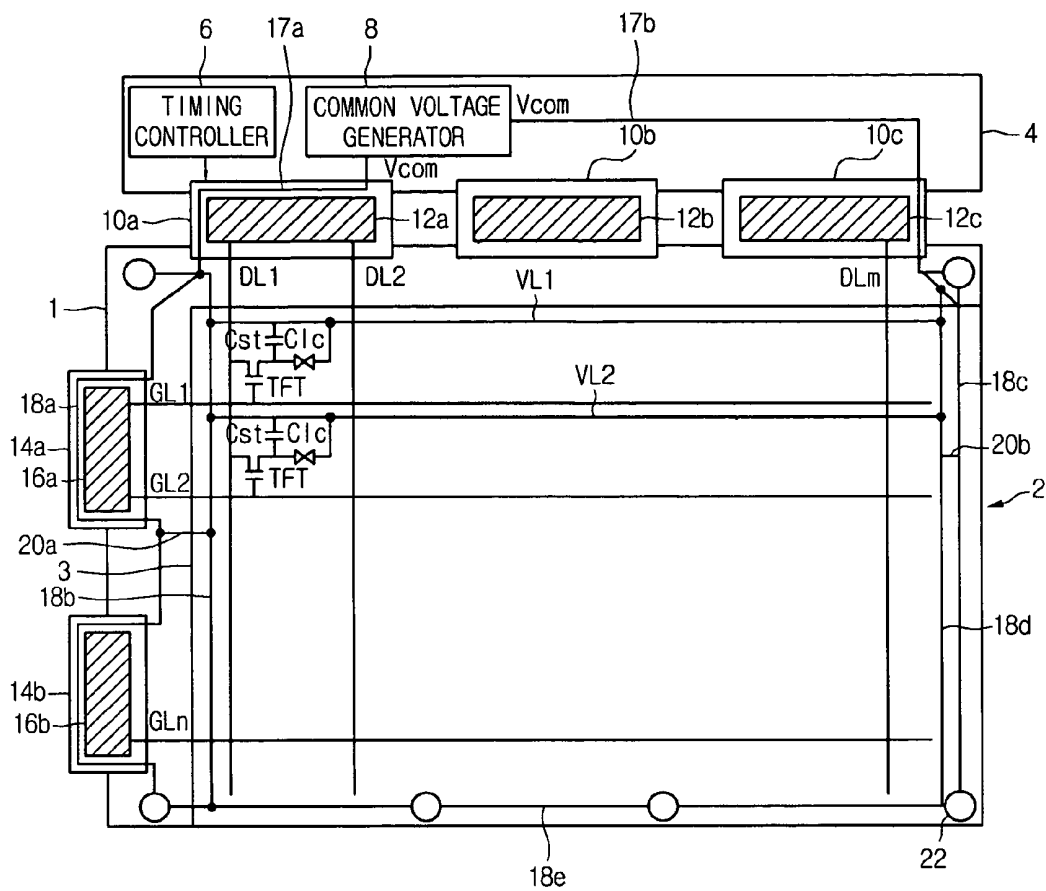

Fig. 2

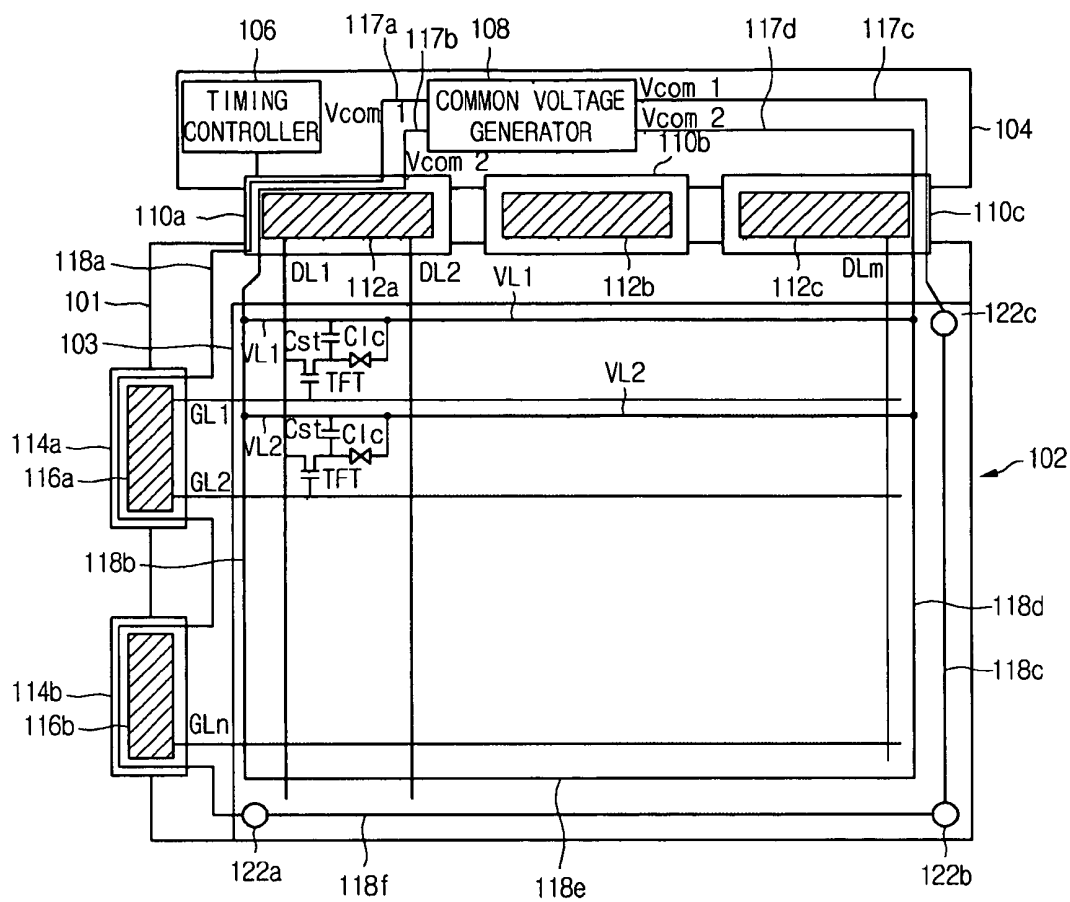
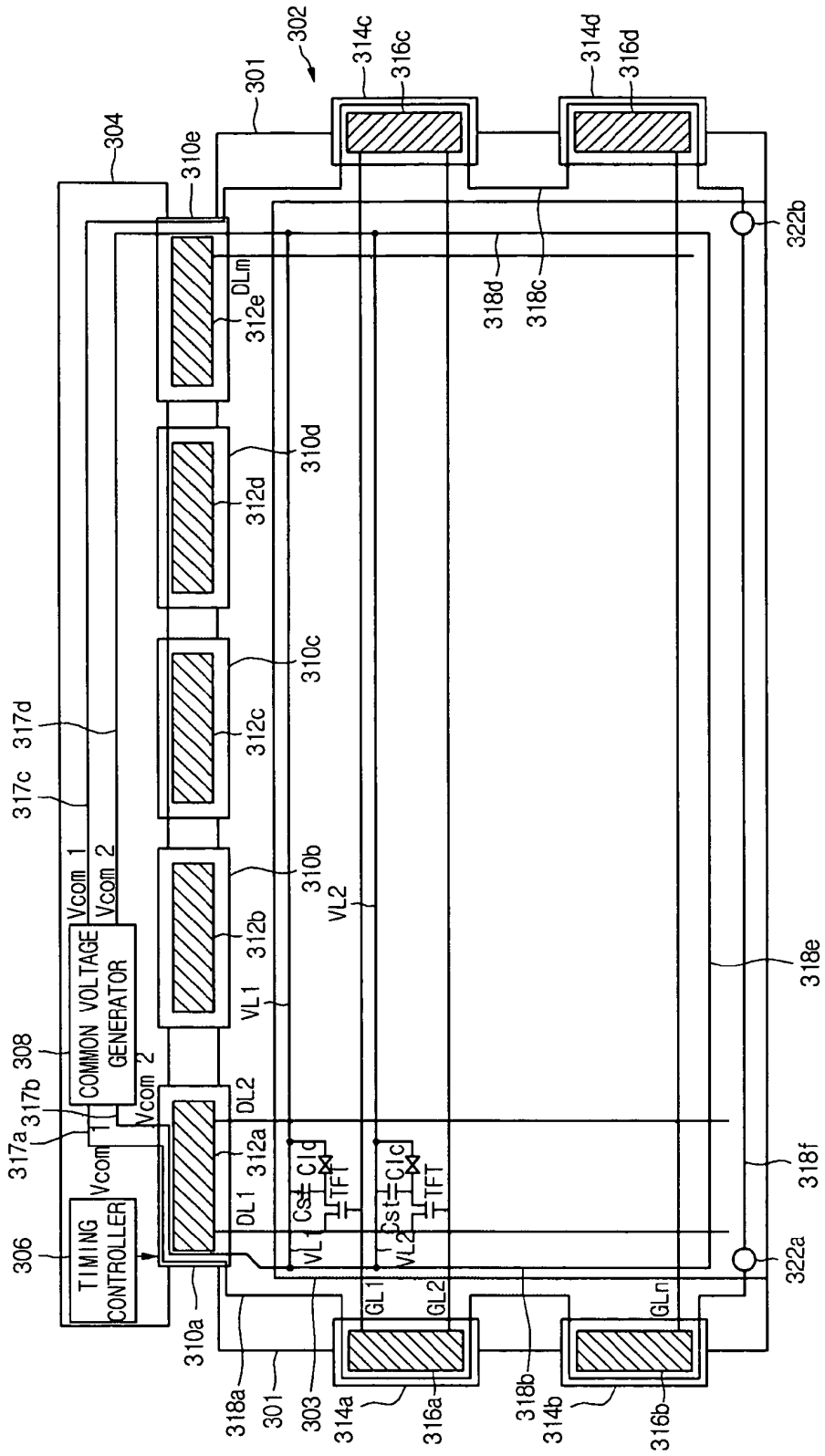

Fig. 3



LIQUID CRYSTAL DISPLAY DEVICE

This application claims the benefit of Korean Patent Application No. 10-2005-0132909, filed on Dec. 29, 2005, which is hereby incorporated by reference for all purposes as if fully set forth herein.

BACKGROUND OF THE INVENTION

1. Field of the Invention

The present invention relates to a liquid crystal display device, and more particularly, to a liquid crystal display device for providing reliable image quality.

2. Discussion of the Related Art

Today's information age demands various forms and types of display devices. In order to satisfy such an increasing demand, there is much ongoing research for developing flat panel display devices such as a liquid crystal display device (LCD), a plasma display panel (PDP) and an electro luminescent display (ELD). Some flat panel display devices have already been utilized in various types of equipment.

Among flat panel display devices, liquid crystal display devices (LCDs) are widely used as a mobile display device instead of using a cathode ray tube (CRT) display device because LCDs are lightweight, slim, and do not consume much power. LCDs are used as monitors for notebook computers and for televisions, for example.

Liquid crystal display devices display images by affecting light transmissivity by controlling the arrangement of liquid crystal molecules.

FIG. 1 is a schematic block diagram of a related art liquid crystal display device.

As shown in FIG. 1, the related art liquid crystal display device includes a liquid crystal panel 2 where a predetermined image is displayed, a PCB 4 disposed at one side of the liquid crystal panel 2, a plurality of data TCPs 10a to 10c interposed between the one side of the liquid crystal panel 2 and the PCB 4, a plurality of data driver ICs 12a to 12c embedded in corresponding data TCPs 10a through 10c, a plurality of gate TCPs 14a and 14b disposed at another side of the liquid crystal panel 2, and a plurality of gate driver ICs 16a and 16b embedded in corresponding gate TCPs 14a and 14b.

The PCB 4 includes various elements. For example, the PCB 4 may include a timing controller 6, a common voltage generator 8 and a power supply (not shown). The timing controller 6 generates a gate control signal for driving the gate driver ICs 16a and 16b and a data control signal for driving the data driver ICs 12a through 12c. The gate control signal is transmitted to the gate driver ICs 16a and 16b through a predetermined gate signal line (not shown). The data control signal is transmitted to the data driver ICs 12a through 12c through a predetermined data signal line (not shown). The common voltage generator 8 generates a predetermined level of a common voltage.

The liquid crystal panel 2 may include a lower substrate 1, an upper substrate 3 and liquid crystal interposed between the lower substrate 1 and the upper substrate 3. A plurality of gate lines GL1 to GLn and a plurality of data lines DL1 to DLm are formed on the lower substrate 1 and the gate and data lines intersect each other, and a thin film transistor (TFT) and a pixel electrode (not shown) are formed at the crossing of the gate lines GL1 to GLn and the data lines DL1 to DLm. Also, a plurality of common lines VL1 to VLn is formed to be parallel to a plurality of gate lines GL1 to GLn. The pixel electrode forms a storage capacitor Cst by overlapping with the common lines. The related art liquid crystal display device is called a storage on common mode. R, G and B color filters

are arranged on the upper substrate 3 and a common electrode is formed on the R, G, B color filters.

The common voltage Vcom generated at the common voltage generator 8 is supplied to a first TCP line 17a and a second TCP line 17b. The first TCP line 17a is formed on the first data TCP 10a in a patterned shape and the second TCP line 17b is formed on the third data TCP 10c in a patterned shape.

A first to a fifth common voltage supplying line 18a to 18e are arranged at edge regions of the lower substrate 1. The first and the second common voltage supplying line 18a and 18b are arranged at a left edge region of the lower substrate 1, and the third and the fourth common voltage supplying line 18c and 18d are arranged at a right edge region of the lower substrate 1. The fifth common voltage supplying line 18e is arranged at a bottom edge region of the lower substrate 1. Furthermore, a silver (Ag) dot 22 is formed roughly at an edge region of the lower substrate 1 for transmitting a common voltage between the lower substrate 1 and the upper substrate 2.

The first TCP line 17a is commonly connected to the first and the second common voltage supplying lines 18a and 18b, and the second TCP line 17b is commonly connected to the third and the fourth common voltage supplying lines 18c and 18d.

The first, the third and the fifth common voltage supplying lines 18a, 18c and 18e are electrically connected to the Ag dot 22. That is, the first and the third common voltage supplying lines 18a and 18c pass a common voltage to a common electrode of the upper substrate 3 through the Ag dot 22. The second and the fourth common voltage supplying lines 18b and 18d are electrically connected to the common lines VL1 to VLn. Therefore, the second and the fourth common voltage supplying lines 18b and 18d transmit a common voltage to the common lines VL1 to VLn.

The common voltage Vcom generated at the common voltage generator 8 is supplied to a plurality of the Ag dots 22 and the first to the fourth common voltage supplying lines 18a to 18d through the first and the second TCP 17a and 17b. Accordingly, the common voltage Vcom is supplied not only to a plurality of common lines VL1 to VLn arranged on the lower substrate 1 but also to a common electrode (not shown) formed on the upper substrate 3. Therefore, the common voltage Vcom is supplied to a plurality of common lines VL1 to VLn for forming the storage capacitor Cst and to the common electrode of the upper substrate 3 through a plurality of the Ag dots 22.

The common voltage Vcom supplied to the common electrode is a driving voltage that drives liquid crystal injected between the upper substrate 3 and the lower substrate 1 with a data voltage supplied to a pixel electrode (not shown). A predetermined image is displayed on the liquid crystal panel 2 by driving the liquid crystal. In order to drive the liquid crystal, a constant common voltage Vcom must be supplied to the common electrode.

Since the liquid crystal panel 2 is of twisted nematic (TN) type and a storage on common structure, a plurality of common lines VL1 to VLn are arranged on the lower substrate 1. As described above, the common voltage Vcom generated at the common voltage generator 8 is supplied to a plurality of common lines VL1 to VLn.

The common voltage Vcom is supplied to the first to the fourth common voltage supplying lines 18a to 18d in an identical manner, a plurality of common lines VL1 to VLn, a plurality of the Ag dots 22 which are formed on the lower substrate 1 and to the common electrode formed on the upper substrate 3.

However, since the common electrode is formed on the entire surface of the upper substrate **3**, the common electrode has a greater sheet resistance than a line resistance of the plurality of common lines VL1 to VLn formed on the lower substrate **1**. Therefore, the common voltage Vcom generated from the common voltage generator **8** is supplied mostly to the plurality of common lines VL1 to VLn which have comparatively low resistance, and the common voltage Vcom is insufficiently supplied to the common electrode. That is, the common voltage is insufficiently supplied to the common electrode in the related art liquid crystal display device. Such an insufficient supply of the common voltage degrades image quality. Therefore, reliable image quality may not be obtained in the related art liquid crystal display device.

SUMMARY OF THE INVENTION

Accordingly, the present invention is directed to a liquid crystal display device that substantially obviates one or more of the problems due to limitations and disadvantages of the related art.

An advantage of the present invention is to provide a liquid crystal display device for providing a quality reliable image by independently supplying different common voltages to a lower substrate and an upper substrate.

Additional features and advantages of the invention will be set forth in the description which follows, and in part will be apparent from the description, or may be learned by practice of the invention. These and other advantages of the invention will be realized and attained by the structure particularly pointed out in the written description and claims hereof as well as the appended drawings.

To achieve these and other advantages and in accordance with the purpose of the invention, as embodied and broadly described, there is provided a liquid crystal display device comprising: a lower substrate having a first and a second common voltage supplying line, pixel regions defined by a plurality of gate lines and a plurality of data lines and said pixel regions arranged in a matrix, and a plurality of common lines electrically connected to the second common voltage supply line and arranged to be parallel to each of the gate lines; an upper substrate disposed to face the lower substrate and having a common electrode electrically connected to the first common voltage supply line; a dot that electrically connects the first common voltage supply line and the common electrode; and a common voltage generator that generates a first and a second common voltage for independently supplying the first and the second common voltage to the first and the second common voltage supply line.

In another aspect of the present invention, there is provided a liquid crystal display device comprising: a lower substrate having a first and a second common voltage supply line, pixel regions defined by a plurality of gate lines and a plurality of data lines and said pixel regions arranged in a matrix, and a plurality of common lines electrically connected to the second common voltage supply line and arranged to be parallel to each of the gate lines; an upper substrate disposed to face the lower substrate and having a common electrode electrically connected to the first common voltage supply line; a dot that electrically connects the first common voltage supply line and the common electrode; a common voltage generator that generates a first and a second common voltage for independently supplying the first and the second common voltage to the first and the second common voltage supply line; a first TCP connected to a first side of the lower substrate;

and a second TCP connected to a second side of the lower substrate and electrically connected to the common voltage generator.

In a further aspect of the present invention, there is provided a liquid crystal display device comprising: a lower substrate having a first and a second common voltage supply line, pixel regions defined by a plurality of gate lines and a plurality of data lines and said pixel regions arranged in a matrix, and a plurality of common lines electrically connected to the second common voltage supply line and arranged to be parallel to each of the gate lines; an upper substrate disposed to face the lower substrate and having a common electrode electrically connected to the first common voltage supply line; a dot that electrically connects the first common voltage supply line and the common electrode; a common voltage generator that generates a first and a second common voltage for independently supplying the first and the second common voltage to the first and the second common voltage supply line; a first and a second TCP connected to a first and a second side of the lower substrate, respectively, which face one another; and a third TCP connected to a third side of the lower substrate and electrically connected to the common voltage generator.

It is to be understood that both the foregoing general description and the following detailed description are exemplary and explanatory and are intended to provide further explanation of the invention as claimed.

BRIEF DESCRIPTION OF THE DRAWINGS

The accompanying drawings, which are included to provide a further understanding of the invention and are incorporated in and constitute a part of this application, illustrate embodiments of the invention and together with the description serve to explain the principles of the invention.

In the drawings:

FIG. 1 is a schematic diagram of a related art liquid crystal display device;

FIG. 2 is a schematic diagram of a liquid crystal display device according to an embodiment of the present invention; and

FIG. 3 is a schematic diagram of a liquid crystal display device according to an embodiment of the present invention.

DETAILED DESCRIPTION OF THE ILLUSTRATED EMBODIMENTS

Reference will now be made in detail to an embodiment of the present invention, example of which is illustrated in the accompanying drawings. Wherever possible, the same reference numbers will be used throughout the drawings to refer to the same or like parts.

FIG. 2 is a schematic diagram of a liquid crystal display device according to a first embodiment of the present invention.

As shown in FIG. 2, the liquid crystal display device according to an embodiment comprises a liquid crystal panel **102** having a plurality of gate lines GL1 to GLn, a plurality of data lines DL1 to DLm and a plurality of common lines VL1 to VLn which are arranged thereon for display a predetermined image, a PCB **104** disposed at a one side of the liquid crystal panel **102**, a plurality of data TCPs **110a** to **110c** disposed between the liquid crystal panel **102** and the PCB **104**, a plurality of gate TCPs **114a** and **114b** connected at another side of the liquid crystal panel **102**, a plurality of data driver ICs **112a** to **112c** embedded in corresponding data

TCPs **110a** to **110c**, and a plurality of gate driver ICs **116a** and **116b** embedded in corresponding gate TCPs **114a** and **114b**.

The PCB **104** includes various elements. For example, the PCB **104** includes a timing controller **106**, a common voltage generator **108** and a power supply (not shown). The timing controller **106** generates a gate control signal for controlling the gate driver ICs **116a** and **116b** and a data control signal for controlling the data driver ICs **112a** to **112c**. The gate control signal is supplied to the gate driver ICs **116a** and **116b** through a gate signal line (not shown). The data control signal is supplied to the data driver ICs **112a** to **112c** through a data signal line (not shown). The common voltage generator **8** generates a predetermined level of common voltage.

The liquid crystal panel **102** includes a lower substrate **101**, an upper substrate **103** and liquid crystal interposed between the lower substrate **101** and the upper substrate **103**. A plurality of gate lines GL1 to GLn and a plurality of data lines DL1 to DLm intersect on the lower substrate **101**, and a thin film transistor (TFT) and a pixel electrode (not shown) are formed at the crossings of the gate lines and the data lines. Also, a plurality of common lines VL1 to VLn are formed substantially in parallel to a plurality of the gate lines GL1 to GLn. The pixel electrode forms a storage capacitor Cst by overlapping with a previous common line. This is known as a storage on common mode. R, G and B color filters are arranged on the upper substrate **103** and a common electrode may be formed on the R, G and B color filters.

A common voltage generated at the common voltage generator **108** may be supplied to a liquid crystal panel **102** through a first to a fourth TCP lines **117a** to **117d**. The first to the fourth TCP lines **117a** to **117d** are formed near the left data TCP, that is, the first data TCP **110a**, and on the most right data TCP **110c**, that is, the fourth data TCP **110c** in a patterned shape. In other words, the first TCP line **117a** and the second TCP line **117b** are formed on the first data TCP **110a**, and the third TCP line **117c** and the fourth TCP line **117d** are formed on the data TCP **110**.

A first to a fifth common voltage supply line **118a** to **118e** are arranged on the lower substrate **101** of the liquid crystal panel **102**. The first and the second common voltage supply lines **118a** and **118b** are arranged near a left side edge region of the lower substrate **101**. The third and the fourth common voltage supply lines **118c** and **118d** are arranged near a right side edge region of the lower substrate **101**. The fifth common voltage supply line **118e** is arranged near a bottom edge region of the lower substrate **101**. The first to the fourth common voltage supply lines **118a** to **118d** are arranged substantially in parallel to the data lines DL1 to DLm, and the fifth common voltage supply line **118e** is arranged substantially in parallel to the gate lines GL1 to GLn. The first common voltage supply line **118a** is electrically connected to the first TCP line **117a**, and the second common voltage supply line **118b** is electrically connected to the second TCP line **117b**. The third common voltage supply line **118c** is electrically connected to the third TCP line **117c** and the fourth common voltage supply line **118d** is electrically connected to the fourth TCP line **117d**. Also, both ends of the fifth common voltage supply line **118e** are electrically connected to the first and the third common voltage supply lines **118a** and **118c**, respectively. The first common voltage supply line **118a** is formed on the gate TCP **114a** and **114b** as well as near the left side edge region of the lower substrate **101**. The second and the fourth common voltage supply lines **118b** and **118d** are electrically connected to the common lines VL1 to VLn. Furthermore, a plurality of Ag dots **122a** to **122c** are

voltage supply line **118a**, and between the third TCP line **117c** and the third common voltage supply line **118c** in order to supply the common voltage to the upper substrate **103** through the lower substrate **101**. The Ag dots **122a** to **122c** may be formed on each of the common voltage supply lines **118a** to **118e**. Therefore, the Ag dots **122a** to **122c** electrically connect each of the common voltage supply lines **118a** to **118e** of the lower substrate **101** with a common electrode of the upper substrate **103**.

The common voltage generator **108** generates a first common voltage Vcom1 and a second common voltage Vcom2 of different values. The first common voltage Vcom1 is supplied to the first TCP line **117a** arranged on the first data TCP **110a** and to the third TCP line **117c** arranged on the third data TCP **110c**. The second common voltage Vcom2 is supplied to a second TCP line **117b** arranged on the first data TCP **110a** and to a fourth TCP line **117d** arranged on the third data TCP **110c**. Then, the first common voltage supplied to the first and the third TCP line **117a** and **117c** is supplied to the common electrode of the upper substrate **103** through the first and the third common voltage supply lines **118a** and **118c** and the Ag dots **122a** to **122c**. The first common voltage Vcom1 may be supplied to the fifth common voltage supply line **118e**. The second common voltage Vcom2 is supplied to the common lines VL1 to VLn through the second and the fourth common voltage supply lines **118b** and **118d**. Therefore, a voltage difference between the second common voltage supplied to the common lines VL1 to VLn of the lower substrate **101** and a data voltage supplied to a pixel electrode is stored at the storage capacitor Cst. The first common voltage Vcom1 supplied to the common electrode of the upper substrate **103** is a reference voltage for displaying an image. Therefore, the image is displayed by the potential difference between the first common voltage Vcom1 and the data voltage supplied to the pixel electrode of each pixel region. The data voltage supplied to a pixel electrode may be charged at the storage capacitor formed between the common lines VL1 to VLn and the pixel electrode by the second common voltage Vcom2.

Therefore, the first common voltage Vcom1 is supplied to the common electrode of the upper substrate **103**, and the second common voltage Vcom2 is supplied to the common lines VL1 to VLn of the lower substrate **101**. As described above, one of the shortcomings of the related art liquid crystal display device, that is, insufficient supply of the common voltage to the common electrode of the upper substrate due to a resistance difference between the line resistance of the common line of the lower substrate and the sheet resistance of the common electrode of the upper substrate, may be overcome by supplying the first common voltage Vcom1 and the second common voltage Vcom2 of different values to the common electrode of the upper substrate **103** and the common lines VL1 to VLn of the lower substrate **101**.

That is, the first common voltage Vcom1 supplied to the common electrode of the upper substrate **103** may be set to be at least greater than the second common voltage Vcom2 supplied to the common lines VL1 to VLn of the lower substrate **101**. Herein, the voltage level of the first common voltage Vcom1 may be decided according to a resistance difference between the sheet resistance of the common electrode of the upper substrate **103** and the line resistance of the common lines VL1 to VLn of the lower substrate **101**. The first common voltage Vcom1 may be set to be comparatively greater than the second common voltage Vcom2 in proportional to the resistance difference between the line resistance and the sheet resistance.

In an exemplary embodiment, the first and the second common voltage Vcom1 and Vcom2 which have different

values are independently supplied to the common electrode of the upper substrate **103** and the common lines VL1 to VLn of the lower substrate **101** in order to stably and sufficiently supply the common voltage to the common electrode. Therefore, the liquid crystal display device according to an embodiment prevents image quality from being degraded by stably and sufficiently supplying a voltage to the common electrode of the upper substrate **103**.

In an embodiment, the gate lines GL1 to GLn of the liquid crystal panel **102** are driven by the gate driver ICs **116a** and **116b** of the gate TCPs **114a** and **114b** which are disposed near one side of the liquid crystal panel **102**.

However, the present invention is not limited thereby. The present invention may be applied to a structure for driving the gate lines GL 1 to GLn of a liquid crystal panel **102** from both sides of the liquid crystal panel **102**. Such a structure will be described hereinafter.

FIG. 3 is a schematic diagram of a liquid crystal display device according to an embodiment of the present invention.

As shown in FIG. 3, the liquid crystal display device according to an embodiment basically has a similar configuration when compared to that of the other embodiment. The liquid crystal display device according to an embodiment comprises a first and a second gate TCP **314a** and **314b** arranged near a left side of a lower substrate **301** and a third and a fourth TCP **314c** and **314d** arranged near a right side of the lower substrate **301**. A first to a fourth gate driver IC **316a** to **316d** are embedded into the first to the fourth gate TCP **314a** to **314d**, respectively.

The liquid crystal display device according to an embodiment includes a PCB **304**, a plurality of gate TCPs **314a** to **314d**, a plurality of data TCPs **310a** to **310e** and a liquid crystal panel **302**.

The PCB **304** is arranged near an upper portion of the liquid crystal panel **302**. The PCB **304** includes a timing controller **306**, a common voltage generator **308** and a power supply (not shown).

The data TCPs **310a** to **310e** are interposed between the PCB **304** and the liquid crystal panel **302**. A first to a fifth data driver IC **312a** to **312e** are embedded in the data TCPs **310a** to **310e**. A first to a fourth TCP line **317a** to **317d** are arranged near some of the data TCPs, the first to the fifth data TCPs **310a** to **310e**. That is, the first and the second TCP line **317a** and **317b** are arranged near the first data TCP **310a**, and the third and the fourth TCP line **317c** and **317d** are arranged near the fifth data TCP **310e**. The data driver ICs **312a** to **312e** supply a predetermined level of data voltage to the liquid crystal panel **302** in response to a control signal generated from the timing controller **306**.

The gate TCPs **314a** to **314d** are arranged near a left side and a right side of the liquid crystal panel **302**. That is, the first and the second gate TCP **314a** and **314b** are connected to the liquid crystal panel **302** near the left side of the liquid crystal panel **302**. The third and the fourth gate TCP **314c** and **314d** are connected to the liquid crystal panel **302** near the right side of the liquid crystal panel **302**. A first to a fourth gate driver ICs **316a** to **316d** are embedded on the first to the fourth gate TCPs **314a** to **314d**. The first to the fourth gate driver ICs **314a** to **314d** sequentially supply a scan signal to the liquid crystal panel **302** in response to a gate control signal generated from the timing controller **306** of the PCB **304**. As described above, the first to the fourth gate driver ICs **316a** to **316d** are disposed near the left side and the right side of the liquid crystal panel **302**, and the scan signals are supplied to both sides of the liquid crystal panel **302**. Therefore, image quality degradation is prevented by compensating a dropped voltage caused by a line resistance.

The liquid crystal panel **302** further comprises a lower substrate **301**, an upper substrate **303** and liquid crystal interposed between the lower substrate **301** and the upper substrate **303**. A plurality of gate lines GL1 to GLn and a plurality of data lines DL1 to DLm cross each other on the lower substrate **301** defining a pixel region. A plurality of common lines VL1 to VLn are arranged in parallel to a plurality of gate lines GL1 to GLn. A thin film transistor (TFT), a switching element, is disposed at the crossing of the gate lines GL1 to GLn and the data lines DL1 to DLm. The TFT is connected to a pixel electrode (not shown). The pixel electrode forms a storage capacitor Cst by overlapping with a plurality of the common lines VL1 and VL2. The storage capacitor Cst maintains a data voltage supplied to the pixel electrode for one frame. A first to a fifth common voltage supply lines **318a** to **318e** are arranged approximately along an edge region of the lower substrate **301**. The first and the second common voltage supply lines **318a** and **318b** are arranged near a left side edge region of the lower substrate **301**, and the third and the fourth common voltage supply lines **318c** and **318d** are arranged near a right side edge region of the lower substrate **303**. The fifth common voltage supply line **318e** is arranged near a bottom edge region of the lower substrate **303**.

Red, Green, and Blue (R, G, B) color filters and a common electrode may be formed on the upper substrate **303**. Ag dots **322a** and **322b** are formed between the upper substrate **303** and the lower substrate **301** in order to transfer a common voltage from the lower substrate **301** to the upper substrate **303**. In more detail, the Ag dots **322a** and **322b** electrically connect the common voltage supply lines **318a** to **318e** of the lower substrate **301** to the common electrode of the upper substrate **303**. More Ag dots than illustrated in the Figures may be incorporated into the invention as needed. Furthermore, the location of the Ag dots may vary as needed.

The liquid crystal panel **302** is of a twisted nematic (TN) mode and a storage on common mode. That is, the liquid crystal panel **302** is the TN mode that twists the liquid crystal using the potential difference between the data voltage supplied to the pixel electrode formed on the lower substrate **301** and the common voltage supplied to the common electrode formed on the upper substrate **303**. Also, the liquid crystal panel **302** is the storage on common mode that charges the pixel electrode with the data voltage to be maintained for one frame.

As described above, different common voltages are independently supplied to the common lines VL1 to VLn of the lower substrate **301** and the common electrode of the upper substrate **303** in order to compensate for sheet resistance of the common electrode that is comparatively greater than the line resistance of the common line. Therefore, the common voltage is stably and sufficiently supplied to the common electrode of the upper substrate **303** and image quality degradation is prevented according to an embodiment of the present invention.

The common voltage generator **308** generates a first and a second common voltage Vcom1 and Vcom2 which have different voltage values. The first common voltage Vcom1 is supplied to the first TCP line **317a** arranged near the first data TCP **310a** and to the third TCP line **217c** arranged near the fifth data TCP **310e**. The second common voltage Vcom2 is supplied to a second TCP line **317b** arranged near the first data TCP **310a** and to a fourth TCP line **317d** arranged near the fifth data TCP **310e**. Therefore, the first common voltage Vcom1 supplied to the first and the third TCP line **317a** and **317c** is supplied to the common electrode of the upper substrate **303** through the first and the third common voltage supply line **318a** and **318c** and the Ag dots **322a** and **322b**.

The first common voltage V_{com1} may be supplied to the fifth common voltage supply line **318e**. The first common voltage supply line **318a** is formed not only near a left side edge region of the lower substrate **301** but also near the first and the second gate TCP **114a** and **114b**. The third common voltage supply line **318c** is formed near the third and the fourth gate TCP **314c** and **314d** as well as near the right side edge region of the lower substrate **301**. The second common voltage V_{com2} is supplied to the common lines VL1 to VLn through the second and the fourth common voltage supply lines **318b** and **318d**. Therefore, the second common voltage V_{com2} supplied to the common lines VL1 to VLn of the lower substrate **301** is a voltage for forming a storage capacitor Cst between a pixel electrode and the common lines, and the first common voltage supplied to the common electrode of the upper substrate **303** is a reference voltage for displaying an image. Therefore, an image is displayed by the potential difference between the first common voltage V_{com1} and the data voltage supplied to a pixel electrode of each pixel region, and the data voltage supplied to the pixel electrode is charged at the storage capacitor formed between the common lines VL1 to VLn and the pixel electrode by the second common voltage V_{com2} .

As described above, the first common voltage V_{com1} is supplied to the common electrode of the upper substrate **303** and the second common voltage V_{com2} is supplied to the common lines VL1 to VLn of the lower substrate **301**, independently. The first and the second common voltage V_{com1} and V_{com2} which are of different voltage values are supplied to the common electrode of the upper substrate **303** and to the common lines VL1 to VLn of the lower substrate **301**. Therefore, one of the shortcomings of the related art LCD, unstable and insufficient supply of a common voltage to a common electrode of an upper substrate, caused by a difference between a line resistance of a common line of a lower substrate and a sheet resistance of a common electrode of an upper substrate, may be solved according to an embodiment of the present invention.

That is, the first common voltage V_{com1} supplied to the common electrode of the upper substrate **303** may be set to be at least greater than the second common voltage V_{com2} supplied to the common lines VL1 to VLn of the lower substrate **301**. Herein, the voltage level of the first common voltage V_{com1} may be decided according to a resistance difference between the sheet resistance of the common electrode of the upper substrate **303** and the line resistance of the common lines VL1 to VLn of the lower substrate **301**. The first common voltage V_{com1} may be set to be comparatively greater than the second common voltage V_{com2} in proportion to the resistance difference between the common lines' line resistance and the common electrode sheet resistance.

In the liquid crystal display device according to an embodiment, the first and the second common voltages V_{com1} and V_{com2} having different values are independently supplied to the common lines VL1 to VLn of the lower substrate **301** and to the common electrode of the upper substrate **303**. Therefore, image quality degradation is prevented by stably and sufficiently supplying the common voltage to the common electrode of the upper substrate **303**.

In an embodiment of the present invention, the gate line is driven from near the left and the right sides of the liquid crystal panel. However, the present invention is not limited by such a structure of driving the gate line. The present invention may be applied to a structure of driving the gate line from near the top and the bottom sides of the liquid crystal panel.

As described above, the common voltage V_{com} is stably and sufficiently supplied to the upper substrate and the lower

substrate by independently supplying the common voltage V_{com} to the upper substrate and the lower substrate in the liquid crystal display device according to the present invention. Therefore, an image quality thereof is improved.

The disclosed technique of independently supplying a common voltage to an upper substrate and a lower substrate may be applied to a structure of driving a gate line from one side, a structure of driving a gate line from both sides, and a structure of driving a data line from both sides. Other variations and modifications are also possible.

It will be apparent to those skilled in the art that various modifications and variations can be made in the present invention without departing from the spirit or scope of the invention. Thus, it is intended that the present invention covers the modifications and variations of this invention provided they come within the scope of the appended claims and their equivalents.

What is claimed is:

1. A liquid crystal display device comprising:

a lower substrate having a first and a second common voltage supply lines, pixel regions defined by a plurality of gate lines and a plurality of data lines and said pixel regions arranged in a matrix, and a plurality of common lines electrically connected to the second common voltage supply line and substantially parallel to each of the gate lines;

an upper substrate disposed to face the lower substrate and having a common electrode electrically connected to the first common voltage supply line;

a plurality of dots that electrically connect the first common voltage supply line and the common electrode; and a common voltage generator that generates a first and a second common voltage for independently supplying the first and the second common voltage to the first and the second common voltage supply lines,

wherein the first common voltage supply line is electrically isolated from and disconnected to the second common voltage supply line,

wherein the first and second common voltage supply lines are arranged substantially parallel to each of the data lines,

wherein the first common voltage supply line is electrically connected to the common electrode of the upper substrate via the plurality of dots, and the second common voltage supply line is electrically connected to the common line of the lower substrate,

wherein the first common voltage is supplied to the common electrode of the upper substrate through the first common voltage supply line and the plurality of dots, and the second common voltage is supplied to the common line of the lower substrate through the second common voltage supply lines, and

wherein the first common voltage supplied to the common electrode is at least greater than the second common voltage supplied to the common lines in proportion to a difference between a line resistance of the common line of the lower substrate and a sheet resistance of the common electrode of the upper substrate.

2. The liquid crystal display device according to claim 1, wherein a storage capacitor is formed by overlapping a pixel electrode arranged at the pixel region and the common line.

3. The liquid crystal display device according to claim 2, wherein the storage capacitor stores a voltage difference between the second common voltage and a data voltage supplied to the pixel electrode.

4. The liquid crystal display device according to claim 1, wherein the first common voltage is a reference voltage to display an image.

5. The liquid crystal display device according to claim 1, wherein the first and the second common voltage supply lines are arranged near an edge region of the lower substrate.

6. The liquid crystal display device according to claim 1, wherein the dot is formed substantially between the first common voltage supply lines.

7. The liquid crystal display device according to claim 1, wherein the dot is formed near the first common voltage supply line.

8. The liquid crystal display device according to claim 1, wherein the first common voltage has a value different from that of the second common voltage.

9. The liquid crystal display device according to claim 1, wherein the first and the second common voltage are selected according to the line resistance of the common line and the sheet resistance of the common electrode.

10. A liquid crystal display device comprising:

a lower substrate having a first and a second common voltage supply lines, pixel regions defined by a plurality of gate lines and a plurality of data lines and said pixel regions arranged in a matrix, and a plurality of common lines electrically connected to the second common voltage supply line and substantially parallel to each of the gate lines;

an upper substrate disposed to face the lower substrate and having a common electrode electrically connected to the first common voltage supplying line;

a plurality of dots that electrically connect the first common voltage supply line and the common electrode;

a common voltage generator that generates a first and a second common voltage for independently supplying the first and the second common voltage to the first and the second common voltage supply lines;

a first gate TCP connected to a first side of the lower substrate; and

a second gate TCP connected to a second side of the lower substrate and electrically connected to the common voltage generator,

wherein the first common voltage supply line is electrically isolated from and disconnected to the second common voltage line,

wherein the first common voltage supply line is electrically connected to the common electrode of the upper substrate via the plurality of dots, and the second common voltage supply line is electrically connected to the common line of the lower substrate and the plurality of dots, and the second common voltage is supplied to the common line of the lower substrate through the second common voltage supply lines, and

wherein the first common voltage supplied to the common electrode is at least greater than the second common voltage supplied to the common lines in proportion to a difference between a line resistance of the common line of the lower substrate and a sheet resistance of the common electrode of the upper substrate.

11. The liquid crystal display device according to claim 10, wherein the first and the second common voltage supply line are arranged near an edge region of the lower substrate.

12. The liquid crystal display device according to claim 10, wherein the dot is substantially between the first common voltage supplying lines.

13. The liquid crystal display device according to claim 10, wherein the dot is formed near the first common voltage supply line.

14. The liquid crystal display device according to claim 10, wherein the first common voltage has a different value from that of the second common voltage.

15. The liquid crystal display device according to claim 10, wherein the first and the second common voltage are selected according to the line resistance of the common line and the sheet resistance of the common electrode.

16. The liquid crystal display device according to claim 10, wherein the first common voltage supply line is formed near an edge region of the lower substrate and the first gate TCP.

17. The liquid crystal display device according to claim 10, wherein a driver TCP is embedded at each of the first and the second gate TCP.

18. A liquid crystal display device comprising:

a lower substrate having a first and a second common voltage supply lines, pixel regions defined by a plurality of gate lines and a plurality of data lines and said pixel regions arranged in a matrix, and a plurality of common lines electrically connected to the second common voltage supply line and substantially parallel to each of the gate lines;

an upper substrate disposed to face the lower substrate and having a common electrode electrically connected to the first common voltage supply line;

a plurality of dots that electrically connect the first common voltage supply line and the common electrode;

a common voltage generator that generates a first and a second common voltage for independently supplying the first and the second common voltage to the first and the second common voltage supply lines;

a first and a second gate TCP connected to a first and a second side of the lower substrate, respectively, which face one another; and

a third gate TCP connected to a third side of the lower substrate and electrically connected to the common voltage generator,

wherein the first common voltage supply line is electrically isolated from and disconnected to the second common voltage line,

wherein the first common voltage supply line is electrically connected to the common electrode of the upper substrate via the plurality of dots, and the second common voltage supply line is electrically connected to the common line of the lower substrate,

wherein the first common voltage is supplied to the common electrode of the upper substrate through the first common voltage supply line and the plurality of dots, and the second common voltage is supplied to the common line of the lower substrate through the second common voltage supply lines, and

wherein the first common voltage supplied to the common electrode is at least greater than the second common voltage supplied to the common lines in proportion to a difference between a line resistance of the common line of the lower substrate and a sheet resistance of the common electrode of the upper substrate.

19. The liquid crystal display device according to claim 18, wherein the first and the second common voltage supply line are arranged near an edge region of the lower substrate.

20. The liquid crystal display device according to claim 18, wherein the dot is substantially between the first common voltage supplying lines.

21. The liquid crystal display device according to claim 18, wherein the dot is formed near the first common voltage supplying line.

13

22. The liquid crystal display device according to claim 18, wherein the first common voltage has a different value from that of the second common voltage.

23. The liquid crystal display device according to claim 18, wherein the first and the second common voltage are selected according to the line resistance of the common line and the sheet resistance of the common electrode.

24. The liquid crystal display device according to claim 18, wherein the first common voltage supply line is formed near an edge region of the lower substrate and the first and the second gate TCP.

25. The liquid crystal display device according to claim 18, wherein a driver TCP is embedded at each of the first to the third gate TCP.

26. The liquid crystal display device according to claim 1, wherein the first common voltage supply line is electrically connected to a first and a third TCP lines, wherein the second common voltage supply line is electrically connected to contacted to a second and a fourth TCP lines, wherein the first and second TCP lines are formed on a first data TCP of a left side edge region of the lower substrate, wherein the third and fourth TCP lines are formed on a second data TCP of a right edge region of the lower substrate.

27. The liquid crystal display device according to claim 10, wherein the first common voltage supply line is electrically connected to a first and a third TCP lines, wherein the second common voltage supply line is electrically connected to a second and a fourth TCP lines, wherein the first and second TCP lines are formed on a first data TCP of a left side edge

14

region of the lower substrate, wherein the third and fourth TCP lines are formed on a second data TCP of a right edge region of the lower substrate.

28. The liquid crystal display device according to claim 18, wherein the first common voltage supply line is electrically connected to a first and a third TCP lines, wherein the second common voltage supply line is electrically connected to a second and a fourth TCP lines, wherein the first and second TCP lines are formed on a first data TCP of a left side edge region of the lower substrate, wherein the third and fourth TCP lines are formed on a second data TCP of a right edge region of the lower substrate.

29. The liquid crystal display device according to claim 1, wherein the second common voltage supply line is formed along an edge region of the lower substrate, and the first common voltage supply line is formed to surround the second common voltage supply line.

30. The liquid crystal display device according to claim 10, wherein the second common voltage supply line is formed along an edge region of the lower substrate, and the first common voltage supply line is formed to surround the second common voltage supply line.

31. The liquid crystal display device according to claim 18, wherein the second common voltage supply line is formed along an edge region of the lower substrate, and the first common voltage supply line is formed to surround the second common voltage supply line.

* * * * *

