



US007710529B2

(12) **United States Patent**
Park et al.

(10) **Patent No.:** **US 7,710,529 B2**
(45) **Date of Patent:** **May 4, 2010**

(54) **LIQUID CRYSTAL DISPLAY PANEL AND METHOD OF MANUFACTURING THE SAME**

(75) Inventors: **Yong Han Park**, Gyeonggi-Do (KR);
Young Nam Yun, Gyeonggi-do (KR); **Ji Hye Moon**, Seoul (KR)

(73) Assignee: **Samsung Electronics Co., Ltd.**,
Gyeonggi-do (KR)

(*) Notice: Subject to any disclaimer, the term of this patent is extended or adjusted under 35 U.S.C. 154(b) by 148 days.

(21) Appl. No.: **11/779,410**

(22) Filed: **Jul. 18, 2007**

(65) **Prior Publication Data**
US 2008/0018843 A1 Jan. 24, 2008

(30) **Foreign Application Priority Data**
Jul. 19, 2006 (KR) 10-2006-0067499

(51) **Int. Cl.**
G02F 1/1345 (2006.01)

(52) **U.S. Cl.** 349/151; 349/139; 349/187

(58) **Field of Classification Search** 349/84,
349/139, 141-143, 147, 149, 187
See application file for complete search history.

(56) **References Cited**

U.S. PATENT DOCUMENTS

6,151,092 A * 11/2000 Fujimura et al. 349/156

2003/0122978 A1 *	7/2003	Lim	349/42
2005/0140281 A1 *	6/2005	Park	313/505
2006/0145985 A1 *	7/2006	Hwang et al.	345/92
2007/0024794 A1 *	2/2007	Kim	349/152
2007/0109483 A1 *	5/2007	Jeoung et al.	349/149
2008/0018245 A1 *	1/2008	Kim et al.	313/512

FOREIGN PATENT DOCUMENTS

JP	2000-89242	3/2000
KR	2005-87516	8/2005
KR	2005-104869	11/2005

* cited by examiner

Primary Examiner—Ellen Kim

(74) *Attorney, Agent, or Firm*—Innovation Counsel LLP

(57) **ABSTRACT**

The present invention provides a liquid crystal display panel and a method of manufacturing the liquid crystal display panel capable of reducing or eliminating metal erosion in an area in which a conductive dot is formed. In some embodiments, a display panel comprises a common electrode formed on an upper substrate, a first electrode formed on a lower substrate opposing the upper substrate and configured to receive a common voltage, a conductive dot formed between the upper substrate and the lower substrate and positioned to supply the common electrode with the common voltage, an insulating layer having a contact hole exposing the first electrode, and a second electrode formed on the insulating layer to connect the conductive dot and the first electrode, wherein a cross sectional area of the conductive dot between the upper substrate and the lower substrate is greater than a cross sectional area of an opening of the contact hole.

13 Claims, 15 Drawing Sheets

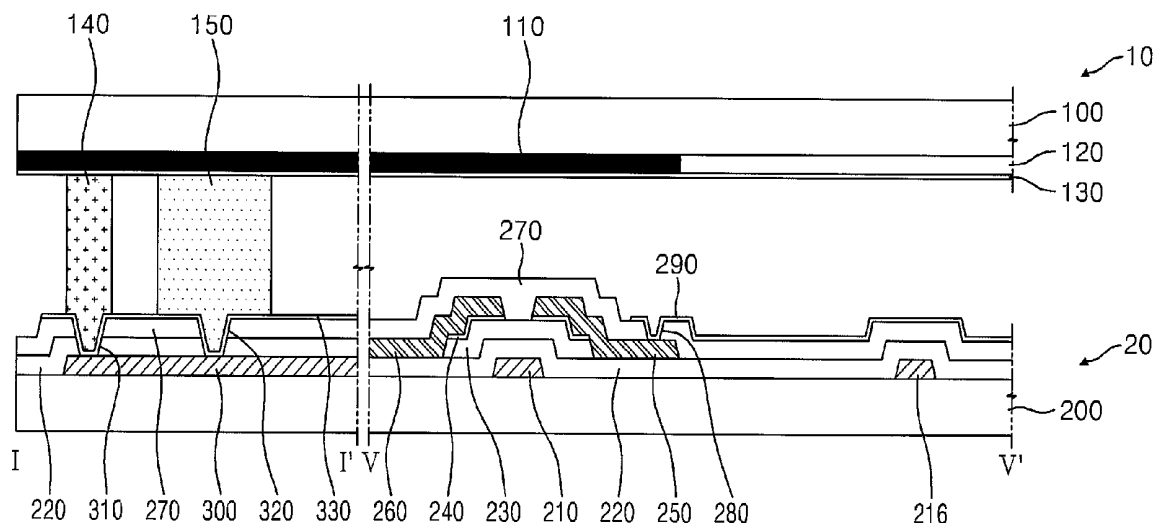

FIG. 1

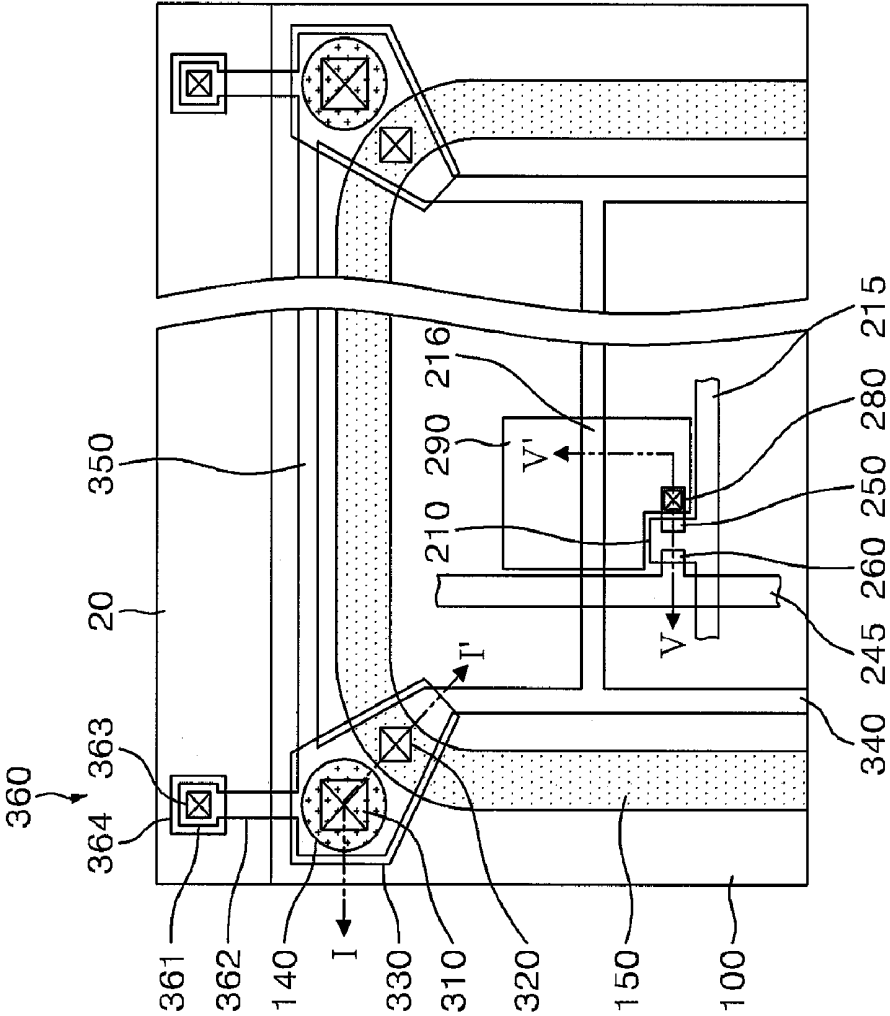

FIG. 2

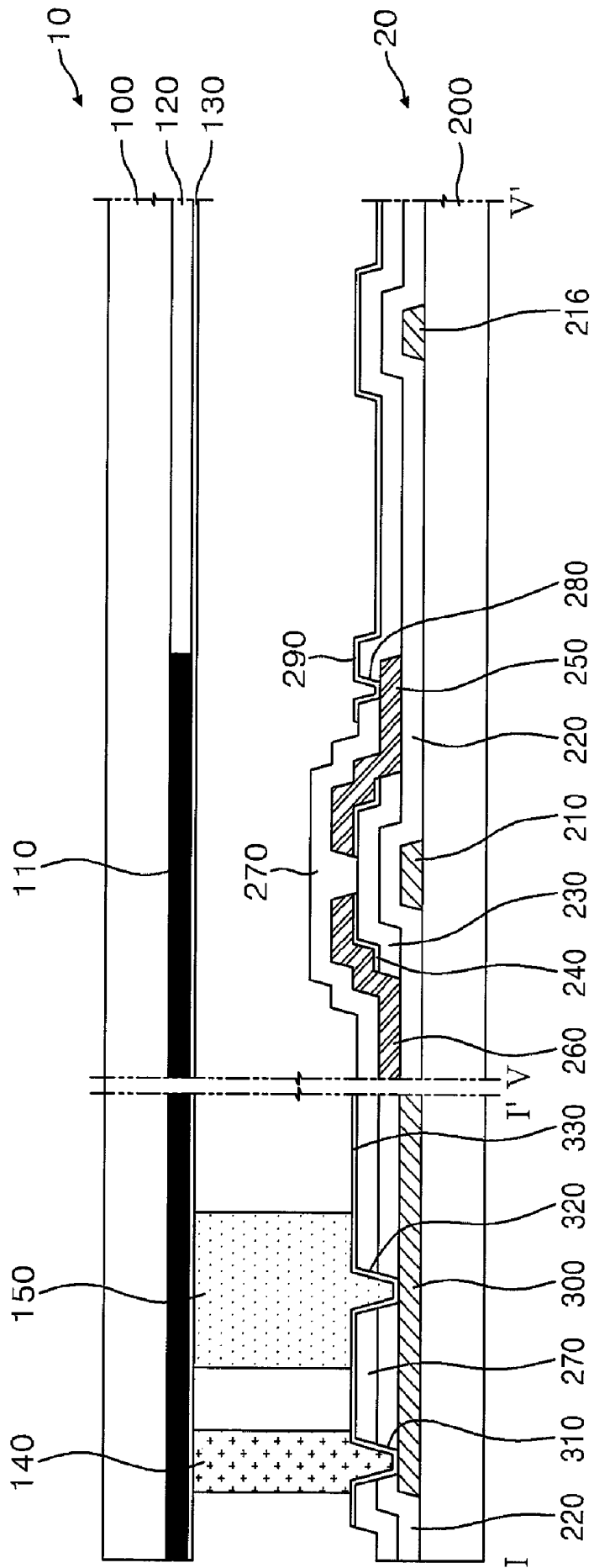

FIG. 3

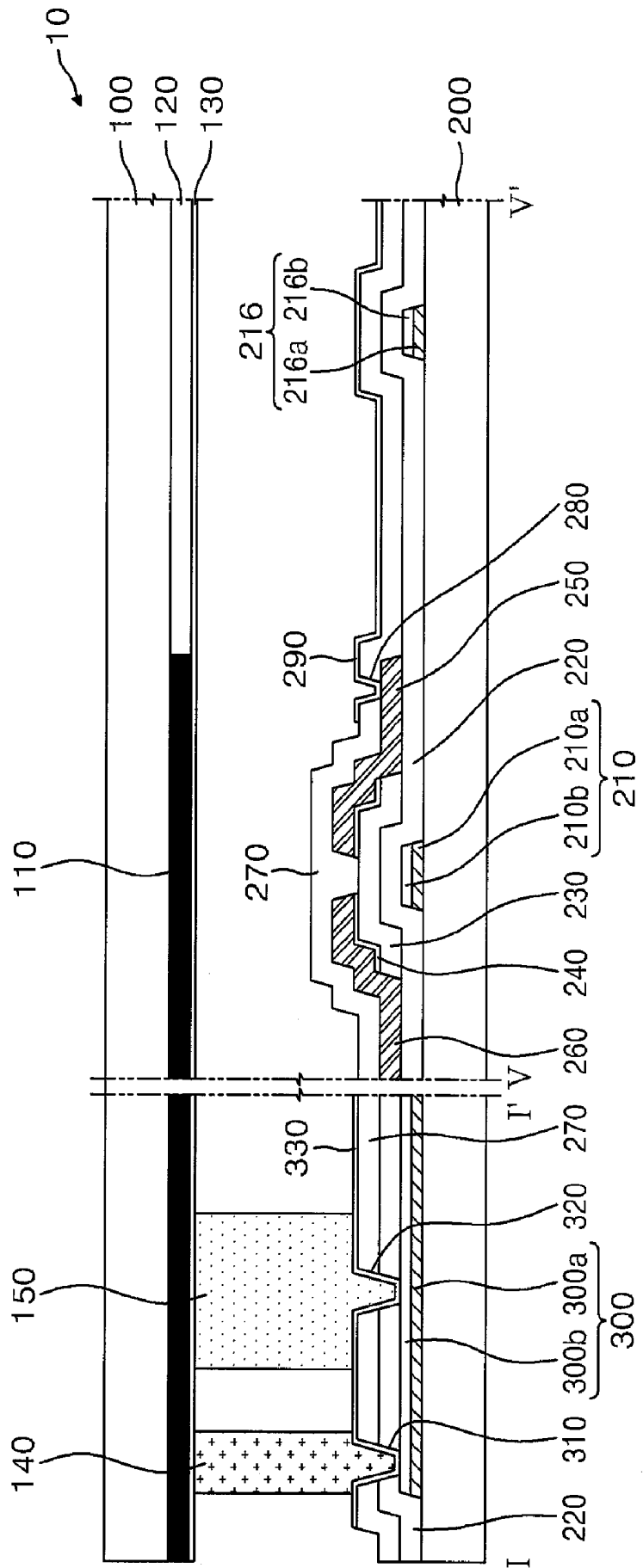

FIG. 4A

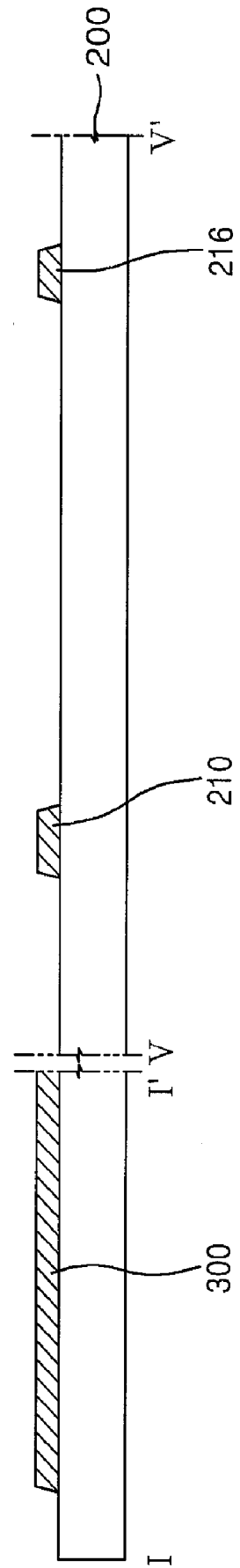

FIG. 4B

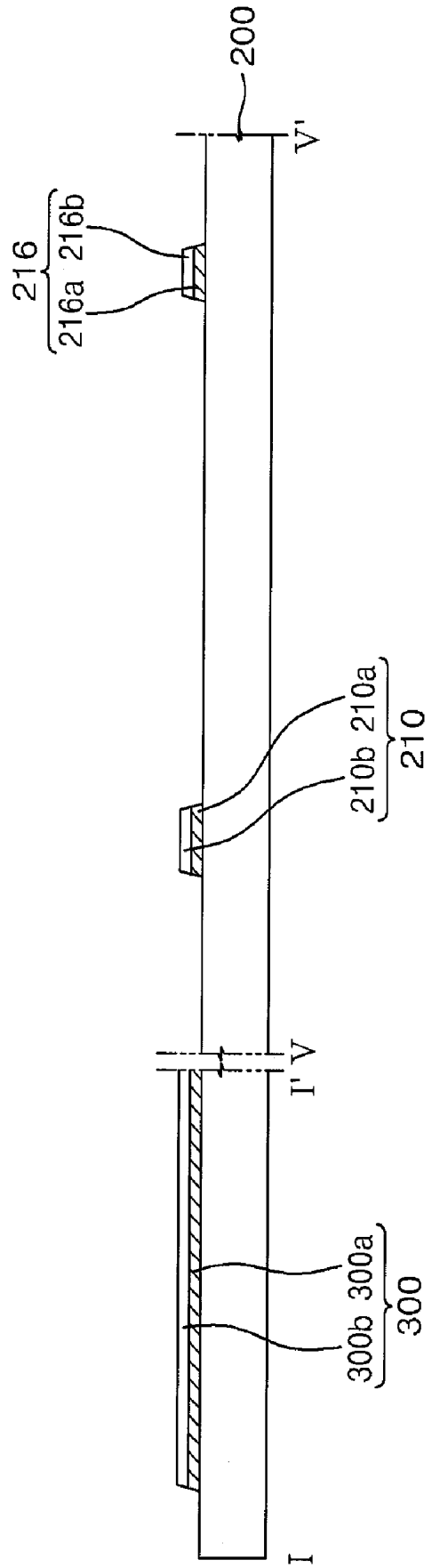

FIG. 5

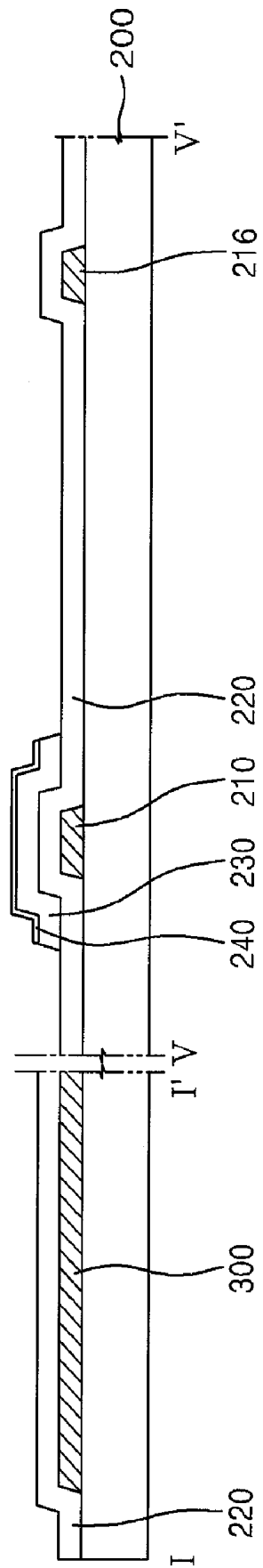

FIG. 6

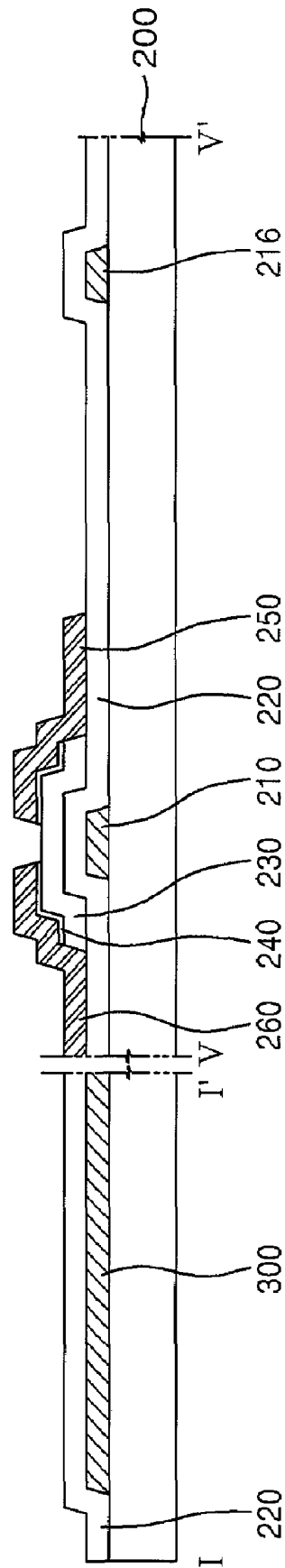

FIG. 7

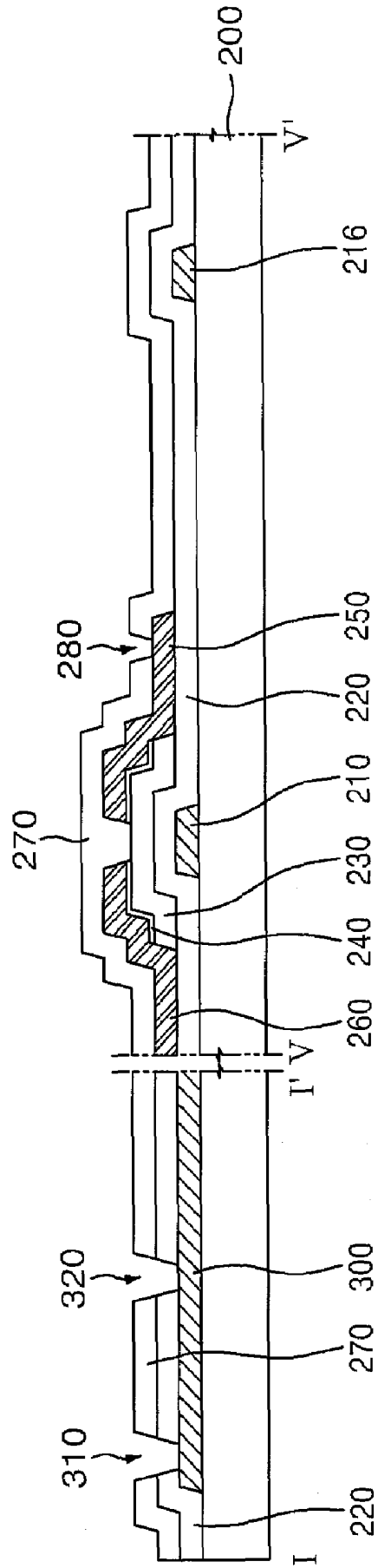

FIG. 8

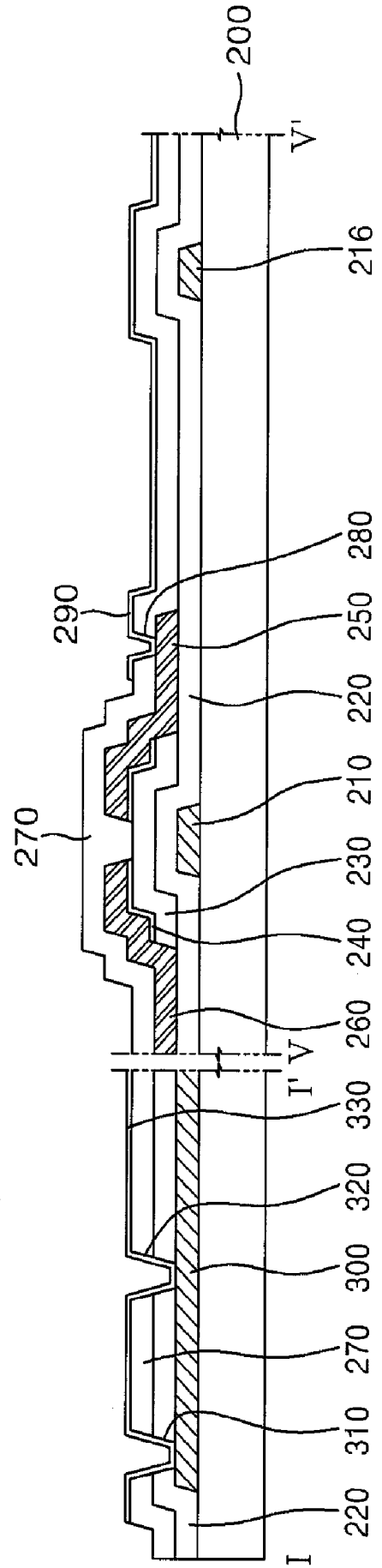

FIG. 10

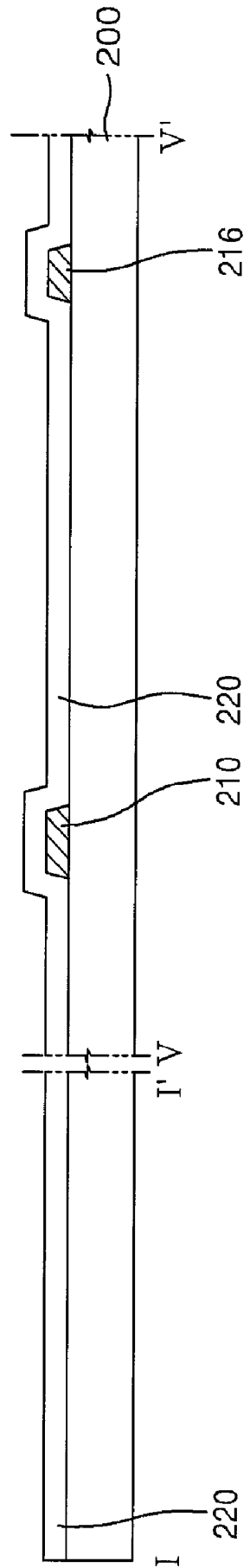

FIG. 11

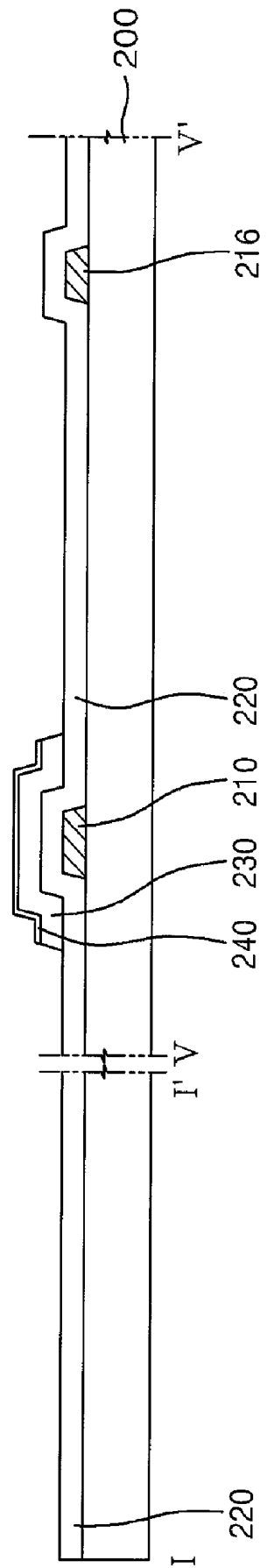

FIG. 12

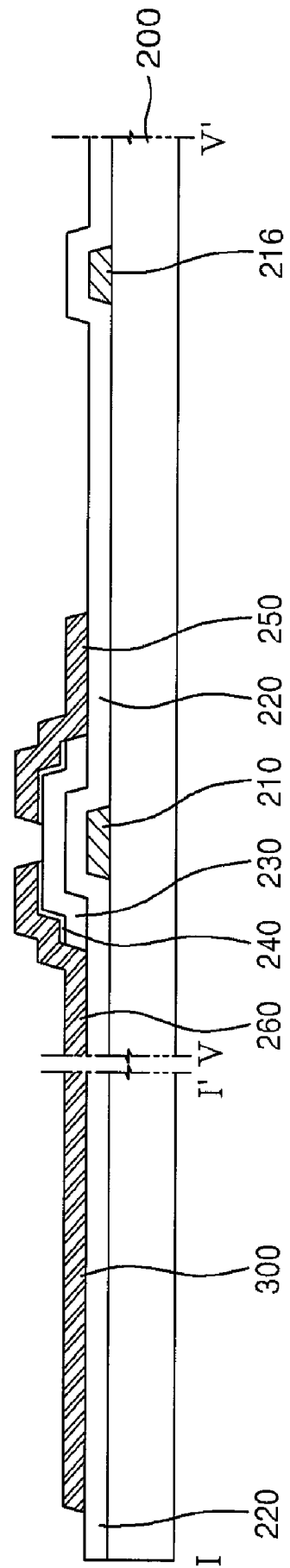

FIG. 13

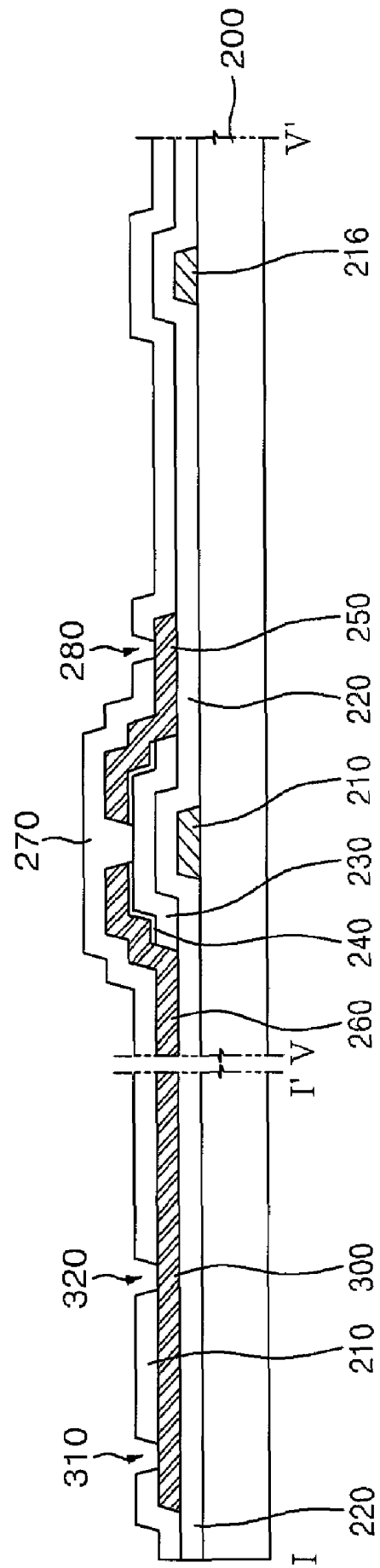
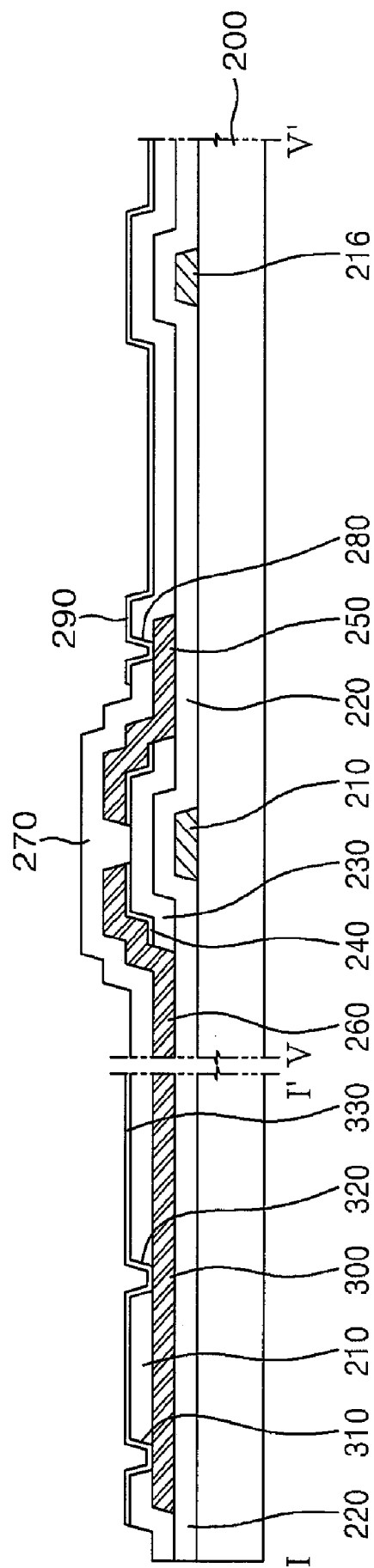

FIG. 14



**LIQUID CRYSTAL DISPLAY PANEL AND
METHOD OF MANUFACTURING THE SAME**CROSS REFERENCE TO RELATED
APPLICATIONS

This application claims priority to Korean Patent Application No. 2006-67499 filed on Jul. 19, 2006 and all the benefits accruing therefrom under 35 U.S.C. §119, and the contents of which in its entirety are herein incorporated by reference.

BACKGROUND OF THE INVENTION

1. Field of the Invention

The present invention relates to a liquid crystal display (“LCD”) panel and a method of manufacturing the LCD panel. More particularly, the present invention relates to an LCD panel and a method of manufacturing the LCD panel capable of reducing or preventing metal erosion due to crack generation by a conductive dot.

2. Description of the Related Art

Recently, CRTs (Cathode Ray Tubes) are most widely used as display devices. However, since CRTs have the difficulty in implementing slim, light products, alternative display types have been developed and used. These display types include flat panel displays (“FPDs”) such as liquid crystal displays (“LCDs”), plasma display panels (“PDPs”), organic light emitting diodes (“OLED”), and other types of flat panel displays. Of these display types, LCDs, which have low power consumption, high resolution, and a large display area, are the most widely used.

LCDs display an image by adjusting light transmittance of a liquid crystal using an electric field. Generally, LCDs include a color filter substrate and a thin film transistor substrate opposing the color filter substrate, with the liquid crystal interposed therebetween.

The color filter substrate includes, as an upper substrate, a black matrix for preventing light leakage, color filters for implementing colors (usually red, green, and blue), and a common electrode for applying a common voltage to the liquid crystal.

The thin film transistor substrate includes, as a lower substrate, gate lines and data lines crossing the gate lines, thin film transistors each formed in pixel regions defined by adjacent crossing gate and data lines, and pixel electrodes connected to the thin film transistors. Additionally, a conductive dot for supplying the common electrode with a common voltage is formed between the thin film transistor substrate and the color filter substrate. A common voltage supplying pad which delivers the common voltage supplied from an external power source is formed on the thin film transistor substrate, as is a contact electrode portion connected to the common voltage supplying pad and the conductive dot.

The contact electrode portion is connected to the common voltage supplying pad, and includes a first contact electrode formed under an insulating layer and a second contact electrode connected to the first contact electrode through a contact hole that penetrates the insulating layer. The conductive dot is formed on the second contact electrode. In order to reduce contact resistances of the first contact electrode and the second contact electrode, the contact hole is formed to have an area greater than a cross-sectional area of the conductive dot.

Because of the pressure of the conductive dot, a crack may be generated on the second contact electrode. Moisture can then penetrate into the first contact electrode through the generated crack, thereby eroding the first contact electrode. In

particular, if the first contact electrode is formed using aluminum or an aluminum alloy, etc. a serious erosion problem may occur.

BRIEF SUMMARY OF THE INVENTION

The present invention provides a liquid crystal display (“LCD”) panel and a method of manufacturing the LCD panel capable of preventing (or reducing the occurrence and/or severity on metal erosion in an area in which a conductive dot is formed.

In an exemplary embodiment of the present invention, a liquid crystal display panel includes a common electrode formed on an upper substrate; a first electrode formed on a lower substrate opposing the upper substrate to receive a common voltage; a conductive dot formed between the upper substrate and the lower substrate and positioned to supply the common electrode with the common voltage; an insulating layer having a contact hole exposing the first electrode; and a second electrode formed on the insulating layer to connect the conductive dot and the first electrode, wherein a cross sectional area of the conductive dot is greater than a cross sectional area of an opening of the contact hole.

The display panel may further comprise a second contact hole connecting the first electrode and the second electrode.

The display panel may further comprise a pixel electrode formed on the lower substrate and configured to generate an electric field in a region between the common electrode and the pixel electrode based on a potential difference between the pixel electrode and the common electrode; and a thin film transistor connected with the pixel electrode.

The display panel may further comprise a storage voltage supply line connected to the first electrode; and a storage electrode forking from the storage voltage supply line and formed to at least partially overlap the pixel electrode.

In some embodiments, the first electrode is formed of the same metal material as that of a gate electrode of the thin film transistor.

In some embodiments, the first electrode includes at least two layers.

In some embodiments, the first electrode may be formed of the same metal material as that of the source electrode and the drain electrode of the thin film transistor.

In some embodiments, second electrode is formed of the same material as that of a pixel electrode.

In some embodiments, a plurality of conductive dots are formed with plural number, and the display panel may further comprise a connection line connecting at least some of the conductive dots with one another.

In some embodiments, the conductive dot is formed of at least one of gold, silver, and alloy thereof.

In an exemplary embodiment of the present invention a method of manufacturing a liquid crystal display panel includes preparing a color filter substrate comprising a common electrode formed on an upper substrate; preparing a lower substrate opposing the upper substrate and comprising a first electrode, an insulating layer having a contact hole exposing the first electrode, a second electrode formed on the insulating layer and in the contact hole adjacent the first electrode to provide electrical communication with the first electrode, a pixel electrode configured to generate an electric field in the region between the common electrode and the pixel electrode based on a potential difference between the pixel electrode and the common electrode, and a thin film transistor connected to the pixel electrode; forming a conductive dot to overlap the contact hole between the common electrode and the second electrode and to overlap an area

peripheral to an opening of the contact hole and in communication with the common electrode and the second electrode; and assembling the upper substrate and the lower substrate.

The method may further comprise forming a second contact hole in the insulating layer to connect the first electrode and the second electrode.

The preparing of the lower substrate may further include forming a storage voltage supply line connected to the first electrode and configured to supply a storage voltage; and forming a storage electrode extending from the storage line and positioned at least partially overlapping the pixel electrode.

In some embodiments, the first electrode is formed of the same metal material as the gate electrode of the thin film transistor.

In some embodiments, first electrode may be formed of two or more layers.

In some embodiments, the first electrode is formed of the same metal as the source electrode and the drain electrode of the thin film transistor.

In some embodiments, forming the conductive dot comprises forming a plurality of conductive dots including a first conductive dot and a second conductive dot, and wherein the method further comprises forming a connection line connecting the first and second conductive dots.

In some embodiments, the conductive dot is formed of at least one of gold, silver, or alloy thereof on the lower substrate.

BRIEF DESCRIPTION OF THE DRAWINGS

The above and other features and advantages of the present invention will become readily apparent by reference to the following detailed description when considered in conjunction with accompanying drawings, wherein:

FIG. 1 is a plan view showing a liquid crystal display (“LCD”) panel in accordance with an exemplary embodiment of the present invention;

FIG. 2 is a cross-sectional view taken along lines I-I' and V-V' of FIG. 1 for showing the LCD panel in accordance with an exemplary embodiment of the present invention;

FIG. 3 is a cross-sectional view showing a cross section of a double-layered gate pattern in the LCD panel shown in FIG. 2;

FIGS. 4A to 8 are cross-sectional views showing a method of manufacturing a thin film transistor substrate with mask processes in accordance with an exemplary embodiment of the present invention;

FIG. 9 is a cross-sectional view of the LCD panel in accordance with an exemplary embodiment of the present invention; and

FIGS. 10 to 14 are cross-sectional views showing a method of manufacturing the thin film transistor substrate with mask processes in accordance with an exemplary embodiment of the present invention.

DETAILED DESCRIPTION OF THE INVENTION

Exemplary embodiments of the present invention are described with reference to the accompanying drawings in detail. The same reference numbers will be used throughout the drawings to refer to the same or like parts. Detailed descriptions of well-known functions and structures incorporated herein may be omitted to avoid obscuring the subject matter of the present invention.

While the present invention is susceptible of embodiment in many different forms, there are shown in drawings and will

be described herein in detail specific embodiments thereof, with the understanding that the present disclosure is to be considered as an exemplification of the principles of the invention and is not intended to limit the invention to the specific embodiments illustrated.

FIG. 1 is a plan view showing a liquid crystal display (“LCD”) panel in accordance with an exemplary embodiment of the present invention, and FIG. 2 is a cross-sectional view taken along lines I-I' and V-V' of FIG. 1 for showing the LCD panel in accordance with a first embodiment of the present invention.

The LCD panel shown in FIGS. 1 and 2 comprises a thin film transistor substrate 20 and a color filter 10 substrate assembled by a sealant 150 with a liquid crystal interposed therebetween. The LCD panel according to an exemplary embodiment of the present invention includes a common electrode 130 formed on an upper substrate 100, a first electrode 300 formed on a lower substrate 200 opposing the upper substrate 100 to receive a common voltage Vcom, a conductive dot 140 formed between the upper substrate 100 and the lower substrate 200 to supply the common voltage Vcom to the common electrode 130, insulating layers 220, 270 having a first contact hole 310 exposing the first electrode 300, and a second electrode 330 formed on the insulating layers 220, 270 to connect the conductive dot 140 and the first electrode 300. The surface area of the first contact hole 310 is formed to be smaller than the surface area of the conductive dot 140.

More specifically, the color filter substrate 10 includes a black matrix 110 and a color filter 120 sequentially formed on the upper substrate 100, and the common electrode 130. The black matrix 110 is formed on the upper substrate 100 in a matrix to divide the upper substrate 100 into a plurality of cell areas in which the color filter 120 is formed, and to prevent light interference of adjacent cells and reflection of external light. The color filter 120 is formed as red, green and blue colors in the cell area divided by the black matrix 110 to transmit red, green, blue light, respectively. The common electrode 130 is a transparent conductive layer deposited on the whole surface of the color filter 120 and in operation supplies the common voltage Vcom, which is a reference value, through the conductive dot 140. Since the color filter 120 has stepped structure, the common electrode 130 formed on the color filter 120 also has stepped structure. An overcoat layer (not shown) may be formed between the color filter 120 and the common electrode 130 and improves the flatness the common electrode 130. Therefore the overcoat layer prevents the common electrode from having a stepped structure.

The thin film transistor substrate 20 includes the thin film transistor connected with a gate line 215 and a data line 245, a pixel electrode 290 connected to the thin film transistor, a common voltage supply line 362 supplying the common voltage Vcom from an external power source (not shown), the first electrode 300 connected with the common voltage supply line 362, and a second electrode 330 connected with the common electrode 130 through the conductive dot 140 and formed to overlap the first electrode 300. Thin film transistor substrate 20 further includes the first contact hole 310 formed to penetrate the insulating layers 220, 270 and exposing the first electrode 300, and the second electrode 330 is connected with the first electrode 300 through the first contact hole 310. The cross sectional area of the conductive dot 140 in the region between substrates 10 and 20 is greater than the cross sectional area of the first contact hole 310 at the opening of first contact hole 310.

The thin film transistor selectively supplies the pixel electrode 290 with a data signal from the data line 245 in response to a gate signal from the gate line 215. In order to do so, the

thin film transistor includes a gate electrode **210** connected to the gate line **215**, a source electrode **260** connected to the data line **245**, and a drain electrode **250** connected to the pixel electrode **290**. An active layer **230** overlaps the gate electrode **210** with the gate insulating layer **220** therebetween, and the active layer forms a channel between the source electrode **260** and the drain electrode **250**. An ohmic contact layer **240** is provided for ohmic contact between the active layer **230** and the drain electrode **250** and the source electrode **260**.

The pixel electrode **290** is connected to the drain electrode **250** exposed through a pixel contact hole **280** in each sub-pixel area. A potential difference between the pixel electrode **290** and the common electrode **130** receiving the common voltage V_{com} generates a vertical electric field. The electric field drives liquid crystal molecules having dielectric birefringence that are aligned between the thin film transistor substrate **20** and the color filter substrate **10**. Light transmittance varies according to the movement of the liquid crystal molecules within the pixel area, so that a gray scale can be implemented by varying the potential difference between the common electrode and the pixel electrode.

A plurality of metal pads which supply an electric signal from outside (for example, a power source signal including the common voltage V_{com} , a control signal, an image signal, etc.) are formed on the thin film transistor substrate **20**, but not overlapping the color filter substrate **10**. Herein, the common voltage pad **360** supplies the common voltage V_{com} and is connected to the first electrode **300**. The common voltage pad **360** includes a first common pad electrode **361**. First common pad electrode **361** may be formed of the same metal material as that of a gate metal, for example, the gate line **215**, the gate electrode **210**, etc. or of the same material as a data metal, for example, the data line **245**, drain and source electrodes **250**, **260**, etc. The common voltage pad **360** further includes common voltage supply line **362** extending from the first common pad electrode **361** and connected with the first electrode **300**, where the pad contact hole **363** is formed to penetrate the gate insulating layer **220** and a protective layer **270**, and the second common pad electrode **364** directly connected to an external power source and connected with the first common pad electrode **361** through the pad contact hole **363**. It is preferable that the second common pad electrode **364** is formed of the same conductive material as that of the pixel electrode **290**.

As shown in FIG. 1, the first electrode **300** is connected through the common voltage supply line **362** and is formed in the non-display area of the thin film transistor substrate **20**. The first electrode **300** is formed of the same metal material as that of the gate metal layer; for example, the gate line **215**, the gate electrode **210**, etc. Accordingly, the first electrode **300** is formed at the same metal layer during the process step in which the gate patterns of the gate line **215**, the gate electrode **210**, etc. are formed. The first electrode **300** may include Cr, Al, Cu, Mo, Ag, or an alloy thereof.

Another embodiment is shown in FIG. 3. As shown in FIG. 3, the gate metal layer may be formed to reduce signal delay in signal transmission and to reduce voltage drop that occurs due to a resistance inside the metal layer. The gate metal layer of FIG. 3 is formed of more than a single layer. In the illustrated embodiment, the gate metal layer has a two layer gate electrode **210a** and **210b**, and a two layer storage electrode **216a** and **216b** to improve contact properties with the lower substrate **200** and the gate insulating layer **220**. The first electrode **300** may be formed of at least two layers; for example, first electrode layers **300a** and **300b** like the gate metal layer. The first contact hole **310** penetrates the gate insulating layer **220** and the protective layer **270** to expose the first electrode **300**. The first contact hole **310** is formed at a

position corresponding to an area where the conductive dot **140** is formed. The first contact hole **310** exposes the first electrode **300**. The cross sectional area of the conductive dot **140** in the region between substrates **10** and **20** is greater than the cross sectional area of the first contact hole **310** at the opening of first contact hole **310**. Accordingly, the conductive dot **140** covers the first contact hole **310** and a peripheral area proximate the first contact hole **310** and blocks humidity that may penetrate from an outside the display panel. As a result, although the second electrode **330** gets damaged due to the conductive dot **140**, penetration of humidity into the first electrode **300** is substantially reduced or eliminated, and thus erosion of the first electrode **300** may be prevented.

The second electrode **330** is connected with the first electrode **300** via the first contact hole **310** and formed to overlap the first electrode **300**. The second electrode **330** may be formed of a conductive material, such as, for example, ITO (Indium Tin Oxide) or IZO (Indium Zinc Oxide), etc. which has a strong waterproof property. In other words, the second electrode **330** is preferably formed of the same conductive material as that of the pixel electrode **290**.

The conductive dot **140** is an element including a conductive dot of silver (Ag) or gold (Au) in a sealant. The conductive dot **140** is formed between the second electrode **330** and the common electrode **130** to supply the common voltage V_{com} applied from outside the display panel an external power source to the common electrode **130**.

Meanwhile, as shown in FIG. 1, the second contact hole **320** is also formed to increase the contact area of the first electrode **300** and the second electrode **330** adjacent to the first contact hole **310**. In other words, when the contact area of the first contact hole **310** is reduced, the contact resistance is increased. As a result, since a voltage drop due to contact resistance occurs when the common voltage V_{com} is supplied to the common electrode **130**, increasing the contact area of the first electrode **300** and the second electrode **330** via the second contact hole **320** and reducing the contact resistance reduces the voltage drop.

The common voltage V_{com} is often used as a storage voltage V_{st} supplied to a storage electrode **216** of the LCD panel. In order to do so, the thin film transistor substrate **20** further includes a storage voltage supply line **340** connected with the first electrode **300**, and the storage electrode **216** forks from the storage voltage supply line **340** (e.g., extends from storage voltage supply line **340** in a perpendicular direction, as shown in FIG. 1).

As shown in FIGS. 1 to 3, the storage voltage supply line **340** is formed of the same metal material as that of a gate metal layer including the gate line **215**, the gate electrode **210**, and the first electrode **300**. The storage voltage supply line **340** is formed parallel to the data line **245** to supply the storage electrode **216** with the storage voltage V_{st} .

The storage electrode **216** forks from the storage voltage supply line **340** and is formed parallel to the gate line **215**. The storage electrode **216** overlaps the pixel electrode **290** to form a storage capacitor. The storage electrode **216** is formed parallel to the gate line **215** or may be formed to overlap the pixel electrode **290** along the peripheral portion of the pixel electrode **290**.

In some embodiments, an LCD panel according to an exemplary embodiment of the present invention may include a plurality of the conductive dots **140**. For example, when the common voltage V_{com} supplied to the common electrode **130** is supplied by a single conductive dot **140**, a small voltage difference can occur between the common voltage V_{com} of one end area of common electrode **130** where the common electrode **130** is connected to the conductive dot **140** and the

common voltage V_{com} of the other end area of the common electrode **130**. In other words, a voltage drop may occur due to resistance of the common electrode **130** while the common voltage V_{com} is supplied from one end to the other end. Further, even if the common voltage V_{com} is used as the storage voltage, voltage drop of the common voltage V_{com} supplied to the common electrode **130** may occur. Accordingly, a plurality of conductive dots **140** may be formed so that the common voltage V_{com} supplied to the common electrode **130** has substantially the same voltage on the front surface of the common electrode **130**.

As shown in FIG. 1, at least one conductive dot **140** is formed at a second corner of the non-display area of the thin film transistor substrate **20** in addition to the conductive dot **140** formed as described above (in a first corner of the non-display area of the thin film transistor substrate **20**). The LCD panel further includes a connection line **350** connecting the conductive dots **140** with one another and extending between adjacent conductive dots **140**. The connection line **350** is formed of the same metal material as that of the first electrode **300** and positioned between the first electrodes **300**.

Referring to FIGS. 1, 4A to 8, a method of manufacturing a thin film transistor substrate according to an exemplary embodiment of the present invention will be now described with reference to a number of mask processes.

FIGS. 4A and 4B are cross-sectional views showing a first mask process in the method of manufacturing the thin film transistor substrate according to a first exemplary embodiment of the present invention.

Referring to FIG. 4A, gate patterns including the gate line **215**, the gate electrode **210**, the first electrode **300**, the common voltage supply line **362**, and the first common pad electrode **361** are formed on the lower substrate **200**.

More specifically, a gate metal layer including a metal material such as Cr, Al, Mo, Ag, Cu, etc., or an alloy thereof is deposited on the lower substrate **200** by a sputtering or other method. Then, gate patterns including the gate line **215**, the gate electrode **210**, the first electrode **300**, the common voltage supply line **362**, and the first common pad electrode **361** are formed using a photolithography process. Additionally, the storage voltage supply line **340** connected with the first electrode **300** and the storage electrode **216** that forks from the storage voltage supply line **340** may be formed at this time. If a plurality of conductive dots is formed, the connection line **350** connecting the first electrodes **300** connected with the conductive dots may also be formed.

In some embodiments, as shown in FIG. 4b, the gate patterns may be formed as multi-layer structures; e.g., with a double layer structure. FIG. 4b shows a gate electrode with layers **210a** and **210b**, a two-layer storage electrode with layers **216a** and **216b**, and a two-layer first electrode with layers **300a** and **300b**. In other words, a double gate metal layer is deposited on the lower substrate **200** using a sputtering or other method, and then the gate pattern is formed by a photolithography process using the same mask to form the double-layered gate pattern.

FIG. 5 is a cross-sectional view showing a second mask process in the method of manufacturing the thin film transistor substrate according to the first exemplary embodiment of the present invention.

Referring to FIG. 5, the gate insulating layer **220** covering the gate pattern is formed on the gate pattern. The gate insulating layer **220** comprises an inorganic material, such as, SiNx or SiOx , etc. After forming gate insulating layer **220**, semiconductor patterns including the active layer **230** formed of an amorphous silicon and the ohmic contact layer **240** formed of an impurity doped amorphous silicon are formed

on the gate insulating layer **220**. The semiconductor patterns are formed by sequentially depositing material for the active layer **230** and the ohmic contact layer **240** and patterning the material by a photolithography process using a second mask.

FIG. 6 is a cross-sectional view showing a third mask process in the method of manufacturing the thin film transistor substrate according to the first exemplary embodiment of the present invention.

Referring to FIG. 6, a data pattern including a data line **245** crossing a gate line **215**, a source electrode **260** connected with the data line **245**, and a drain electrode **250** facing the source electrode **260** is formed on a gate insulating layer **220** and on the semiconductor patterns. The data pattern is formed by depositing a data metal layer on the gate insulating layer **220** and the semiconductor patterns (including active layer **230** and ohmic contact layer **240**) and patterning the data metal layer using a third mask by a photolithography process. The data metal layer may include a metal, such as, Al, Mo, Cu, Cr, Ti, etc. or alloy thereof.

Then, the active layer **230** is exposed by removing the ohmic contact layer **240** between the source electrode **260** and the drain electrode **250**.

Although the method of manufacturing the thin film transistor substrate according to the first exemplary embodiment of the present invention describes that the semiconductor patterns including layers **230** and **240** and the data patterns including elements **245**, **250**, and **260** are formed using a different mask, the semiconductor patterns (including elements **230**, **240**) and the data patterns (including elements **245**, **250**, and **260**) may be formed using a same mask. The mask may be, for example, a slit mask partially patterning an aperture portion or a two-tone mask forming a different thickness in each area, etc.

FIG. 7 is a cross-sectional view showing a fourth mask process in the method of manufacturing the thin film transistor substrate according to the first exemplary embodiment of the present invention.

Referring to FIG. 7, a protective layer **270** covering a data pattern is formed on a lower substrate **200** and patterned by a photolithography process using a fourth mask to form first and second contact holes **310** and **320** exposing parts of the first electrode **300**, as well as a pixel contact hole **280** exposing a drain electrode **250**. Herein, the first contact hole **310** is formed in an area where the conductive dot **140** will be formed, and the cross sectional area of the conductive dot **140** in the region between substrates **10** and **20** is greater than the cross sectional area of the first contact hole **310** at the opening of first contact hole **310**. In some embodiments, the protective layer **270** is formed of the same inorganic insulating material as that of the gate insulating layer **220**, while in some embodiments protective layer **270** may be formed of an organic insulating material.

FIG. 8 is a cross-sectional view showing a fifth mask process in the method of manufacturing the thin film transistor substrate according to the first exemplary embodiment of the present invention.

Referring to FIG. 8, a transparent conductive pattern including a pixel electrode **290** connected to a drain electrode **250** via a pixel contact hole **280** and a second electrode **330** connected to the first electrode **300** via the first and second contact holes **310** and **320** is formed on a protective layer **270**. The pixel electrode **290** and the second electrode **330** are formed by depositing transparent conductive material, such as ITO (Indium Tin Oxide) or IZO (Indium Zinc Oxide), etc. on the protective layer **270** and patterning by a photolithography process using a fifth mask.

The conductive dot **140** is formed on the thin film transistor substrate **20** thus formed, and the thin film transistor substrate **20** and the color filter substrate **10** on which the common electrode **130** is formed are sealed by a sealant **150** to form the LCD panel. At this time, the conductive dot **140** supplies the common electrode **130** with the common voltage supplied from an external power source.

Meanwhile, the first electrode **300** may be formed of the same metal material as that of the data pattern elements such as the source electrode **260**, the drain electrode **250**, and the data line **245**, etc.

FIG. **9** is a cross-sectional view showing a cross section of the LCD panel according to a second exemplary embodiment of the present invention.

FIG. **9** shows the same configuration as that of FIG. **2**, except that a first electrode **300** is formed of the data metal. Accordingly, detailed description of elements described above with reference to FIG. **2** may be omitted.

Referring to FIGS. **1** and **9**, the first electrode **300** is formed of the data metal. Accordingly, the LCD panel further includes a contact hole connecting the first electrode **300** with a common voltage supply line **362** formed of a gate metal and a storage voltage supply line **340**.

Meanwhile, when one or more conductive dots **140** and the connection lines connecting the conductive dots **140** are formed, a contact hole to connect the first electrode **300** and the connection line **350** is also formed. Further, the connection line **350** may be formed of the same metal material as that of the first electrode **300**.

In some embodiments, the storage voltage supply line **340**, the common voltage supply line **362**, and the connection line **350** may be formed of the data metal layer.

FIGS. **10** to **14** are cross-sectional views showing the method of manufacturing the thin film transistor substrate according to the second exemplary embodiment of the present invention. FIGS. **10** to **14** show the same processes as those of FIGS. **4** to **8** except that the first electrode **300** is formed of the data pattern. Accordingly, detailed description of processes described above may be omitted. The following description refers to FIGS. **1** and **10** to **14**.

FIG. **10** is a cross-sectional view showing a first mask process in the method of manufacturing the thin film transistor substrate according to the second exemplary embodiment of the present invention.

Referring to FIG. **10**, a gate pattern including a gate line **215**, a gate electrode **210**, a common voltage supply line **362**, a first common pad electrode **361**, a storage voltage supply line **340**, and a storage electrode **216**, is formed on a lower substrate **200**.

More specifically, a gate metal layer including a metal material such as Cr, Al, Mo, Ag, Cu, etc. or alloy thereof is deposited on the lower substrate **200** using a sputtering or other appropriate method. Then, a gate pattern including the gate line **215**, the gate electrode **210**, the common voltage supply line **362**, the first common pad electrode **361**, the storage voltage supply line **340**, and the forked storage electrode **216**, is formed using a photolithography process. In embodiments in which a plurality of the conductive dots is formed, a connection line **350** connecting conductive dots **140** to one another may also be formed.

FIG. **11** is a cross-sectional view showing a second mask process in the method of manufacturing the thin film transistor substrate according to the second exemplary embodiment of the present invention.

Referring to FIG. **11**, a gate insulating layer **220** covering the gate pattern, the active layer **230** formed on the gate insulating layer **220** of amorphous silicon, and the ohmic

contact layer **240** formed of impurity doped amorphous silicon are deposited and then patterned by a photolithography process using a second mask to form semiconductor patterns including layers **230** and **240**.

FIG. **12** is a cross-sectional view showing a third mask process in the method of manufacturing the thin film transistor substrate according to the second exemplary embodiment of the present invention.

Referring to FIG. **12**, a data pattern including the data line **245** crossing the gate line **215**, a source electrode **260** connected to the data line **245**, and a drain electrode **250**, as well as a first electrode **300** facing the source electrode **260** are formed on the gate insulating layer **220** and the semiconductor patterns including layers **230** and **240**. The first common pad electrode **361** of the common voltage pad **360** to be connected to an external power source is formed of the data metal layer, not the gate metal layer, and thus may be connected to the first electrode **300**. If a plurality of conductive dots **140** is formed, the connection line **350** connecting conductive dots **140** to one another may also be formed of the data metal layer. The data pattern is formed by depositing the data metal layer and then patterning the data metal layer using a photolithography process. In some embodiments, the data metal layer may include a metal, for example, Al, Mo, Cu, Cr, Ti, etc. or alloy thereof. The active layer **230** is exposed by removing a portion of the ohmic contact layer **240** between the source electrode **260** and the drain electrode **250**.

In some embodiments, the semiconductor pattern and the data pattern may be simultaneously formed by depositing a gate insulation layer, an active layer, an impurity doped ohmic contact layer, and a data metal layer. The deposited layers may then be patterned by the photolithography process using one mask.

FIG. **13** is a cross-sectional view showing a fourth mask process in the method of manufacturing the thin film transistor substrate according to the second exemplary embodiment of the present invention.

Referring to FIG. **13**, the protective layer **270** covering the data pattern is formed on the lower substrate **200** and then patterned to form the first and second contact holes **310**, **320** exposing the first electrode **300**, the pixel contact hole **280** exposing the drain electrode **250**, and a further contact hole exposing part of the first electrode **300** connecting the first electrode **300** and the storage voltage supply line **340**. Herein, the first contact hole **310** is formed in an area where the conductive dot will be formed, and the cross sectional area of the conductive dot **140** in the region between substrates **10** and **20** is greater than the cross sectional area of the first contact hole **310** at the opening of first contact hole **310**. The protective layer **270** may be formed of the same inorganic insulating material as that of the gate insulating layer **220**, or may be formed of an organic insulating material.

FIG. **14** is a cross-sectional view showing a fifth mask process in the method of manufacturing the thin film transistor substrate according to the second exemplary embodiment of the present invention.

Referring to FIG. **14**, a transparent conductive pattern, including the pixel electrode **290** connected to the drain electrode **250** via the pixel contact hole **280** and the second electrode **330** connected to the first electrode **300** via the first and second contact holes **310**, **320** is formed on the protective layer **270**. The pixel electrode **290** and the second electrode **330** are formed by depositing transparent conductive material such as ITO (Indium Tin Oxide), IZO (Indium Zinc Oxide), or other appropriate material on the protective layer **270** and then patterning using a photolithography process.

As described above, according to the LCD panel and the method of manufacturing the same according to the present invention, in the area in which the conductive dot formed between the color filter substrate and the thin film transistor substrate supplying the common voltage is formed, the cross sectional area of the conductive dot is greater than the cross sectional area of the opening of the first contact hole. The conductive dot is formed to cover the contact holes and an area adjacent the periphery of the contact holes. As a result, erosion of the electrode due to the penetration of humidity may be prevented.

Further, a contact hole reducing the contact resistance between electrodes is also formed, thereby preventing an increase of the contact resistance between the electrodes.

While this invention has been described in connection with what is presently considered to be practical exemplary embodiments, it is to be understood that the invention is not limited to the disclosed embodiments, but, on the contrary, is intended to cover various modifications and equivalent arrangements included within the spirit and scope of the appended claims.

What is claimed is:

1. A liquid crystal display panel comprising:

a common electrode formed on an upper substrate;
a first electrode formed on a lower substrate opposing the upper substrate and configured to receive a common voltage;

a conductive dot formed between the upper substrate and the lower substrate and positioned to supply the common electrode with the common voltage;

an insulating layer having a contact hole exposing the first electrode; and

a second electrode formed on the insulating layer to connect the conductive dot and the first electrode and making contact with the first electrode through the contact hole,

wherein a cross sectional area of the conductive dot is greater than a cross sectional area of an opening of the contact hole, and the conductive dot contacts at least a portion of the second electrode that makes contact with the first electrode.

2. The liquid crystal display panel of claim 1, further comprising a second contact hole exposing the first electrode and wherein the second electrode is connected to the first electrode through the second contact hole.

3. The liquid crystal display panel of claim 2, wherein the liquid crystal display panel comprises a pixel electrode formed on the lower substrate and configured to generate an electric field in a region between the common electrode and the pixel electrode based on a potential difference between the pixel electrode and the common electrode, and further comprising a thin film transistor connected to the pixel electrode.

4. The liquid crystal display panel of claim 3, further comprising:

a storage voltage supply line connected to the first electrode; and

a storage electrode forking from the storage voltage supply line and formed to at least partially overlap the pixel electrode.

5. The liquid crystal display panel of claim 4, wherein the thin film transistor comprises a gate electrode formed of a first metal material, and wherein the first electrode is formed of the first metal material.

6. The liquid crystal display panel of claim 5, wherein the first electrode comprises a layer formed of the first metal material and comprises at least one additional layer comprising a material different than the first metal material.

7. The liquid crystal display panel of claim 4, wherein the thin film transistor comprises a source electrode and a drain electrode formed of a particular metal material, and wherein the first electrode is formed of the particular metal material.

8. The liquid crystal display panel of claim 3, wherein the second electrode is formed of the same conductive material as that of the pixel electrode.

9. The liquid crystal display panel of claim 1, wherein the display panel comprises a plurality of conductive dots including a first conductive dot and a second conductive dot, and further comprises a connection line connecting the first conductive dots and the second conductive dot.

10. The liquid crystal display panel of claim 1, wherein the conductive dot comprises at least one material selected from the group consisting of gold, silver, a gold alloy, and a silver alloy.

11. A liquid crystal display comprising:

a first substrate comprising a common electrode;

a second substrate comprising a first electrode and an insulating layer on the first electrode, the insulating layer being provided with a contact hole positioned to provide contact with the first electrode, the contact hole having an opening with a cross sectional area; and

a conductive dot in electrical communication with the common electrode and the first electrode; and

a second electrode formed on the insulating layer and making contact with the first electrode through the contact hole,

wherein the conductive dot has at least a portion extending from the first substrate to the second substrate, the conductive dot has a conductive dot cross sectional area, the cross sectional area of the opening of the contact hole is smaller than the conductive dot cross sectional area, and the conductive dot contacts at least a portion of the second electrode that makes contact with the first electrode.

12. The liquid crystal display panel of claim 1, wherein the first electrode comprises at least one material selected from the group consisting of chromium, aluminum, copper, molybdenum, silver, a chromium alloy, an aluminum alloy, a copper alloy, a molybdenum alloy, and a silver alloy.

13. The liquid crystal display of claim 11, wherein the first electrode comprises at least one material selected from the group consisting of chromium, aluminum, copper, molybdenum, silver, a chromium alloy, an aluminum alloy, a copper alloy, a molybdenum alloy, and a silver alloy.

专利名称(译)	液晶显示面板及其制造方法		
公开(公告)号	US7710529	公开(公告)日	2010-05-04
申请号	US11/779410	申请日	2007-07-18
[标]申请(专利权)人(译)	PARK勇悍 YUN YOUNG NAM MOON JI HYE		
申请(专利权)人(译)	PARK勇悍 YUN YOUNG NAM MOON JI HYE		
当前申请(专利权)人(译)	SAMSUNG ELECTRONICS CO. , LTD.		
[标]发明人	PARK YONG HAN YUN YOUNG NAM MOON JI HYE		
发明人	PARK, YONG HAN YUN, YOUNG NAM MOON, JI HYE		
IPC分类号	G02F1/1345		
CPC分类号	G02F1/1339 G02F1/1345 G02F1/133512 G02F2201/121 G02F1/1362 G02F1/13394		
优先权	1020060067499 2006-07-19 KR		
其他公开文献	US20080018843A1		
外部链接	Espacenet USPTO		

摘要(译)

本发明提供一种液晶显示面板和制造该液晶显示面板的方法，该液晶显示面板能够减少或消除形成导电点的区域中的金属腐蚀。在一些实施例中，显示面板包括形成在上基板上的公共电极，形成在与上基板相对的下基板上并且被配置为接收公共电压的第一电极，形成在上基板和下基板之间的导电点，以及定位为公共电极提供公共电压，绝缘层具有暴露第一电极的接触孔，第二电极形成在绝缘层上以连接导电点和第一电极，其中导电的横截面积上基板和下基板之间的点大于接触孔的开口的横截面积。

