



US007321355B2

(12) **United States Patent**
Lee et al.

(10) **Patent No.:** US 7,321,355 B2
(45) **Date of Patent:** Jan. 22, 2008

(54) **LIQUID CRYSTAL DISPLAY**

(56) **References Cited**

(75) Inventors: **Seok Lyul Lee**, Tao-Yuan Hsien (TW);
Po Sheng Shih, Tao-Yuan Hsien (TW)

U.S. PATENT DOCUMENTS

(73) Assignee: **Hannstar Display Corporation**, Taipei (TW)

5,933,202 A * 8/1999 Watanabe et al. 349/33
7,030,843 B2 * 4/2006 Youn 345/86
2002/0180681 A1 * 12/2002 Shen 345/94

(*) Notice: Subject to any disclaimer, the term of this patent is extended or adjusted under 35 U.S.C. 154(b) by 741 days.

* cited by examiner

(21) Appl. No.: **10/777,164**

Primary Examiner—Ricardo Osorio
(74) *Attorney, Agent, or Firm*—Volentine & Whitt, PLLC

(22) Filed: **Feb. 13, 2004**

(57) **ABSTRACT**

(65) **Prior Publication Data**

US 2004/0196241 A1 Oct. 7, 2004

(30) **Foreign Application Priority Data**

Mar. 7, 2003 (TW) 92105061 A

A liquid crystal display replaces the common electrodes of a conventional LCD with a plurality of switch electrodes. The plurality of switch electrodes is grouped into several switch electrode sets. Each of the switch electrode sets' potential is modulated by a different driving circuit. The driving circuits can also separately modulate the potentials of the switch electrode sets according to the scanning sequence of the LCD.

(51) **Int. Cl.**
G09G 3/36 (2006.01)

(52) **U.S. Cl.** 345/103; 345/87

(58) **Field of Classification Search** 345/87,
345/90-92, 94-96, 103

See application file for complete search history.

15 Claims, 8 Drawing Sheets

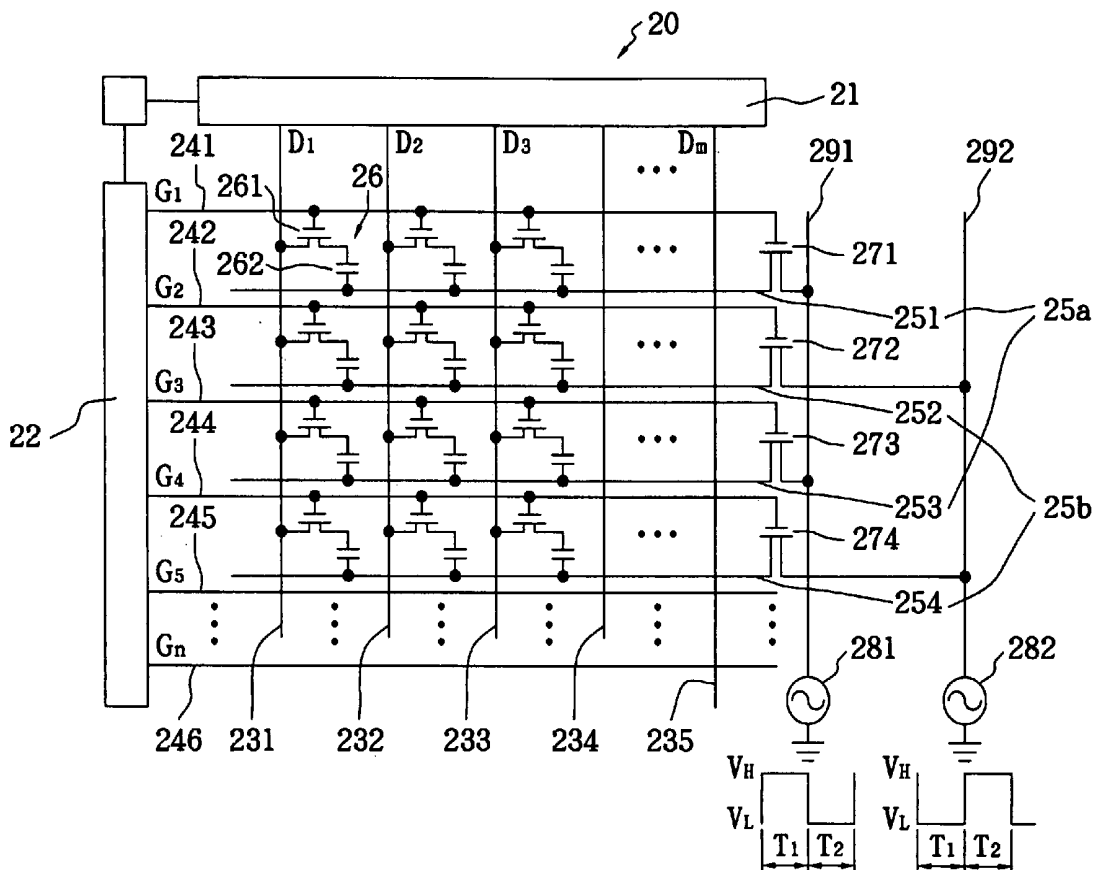

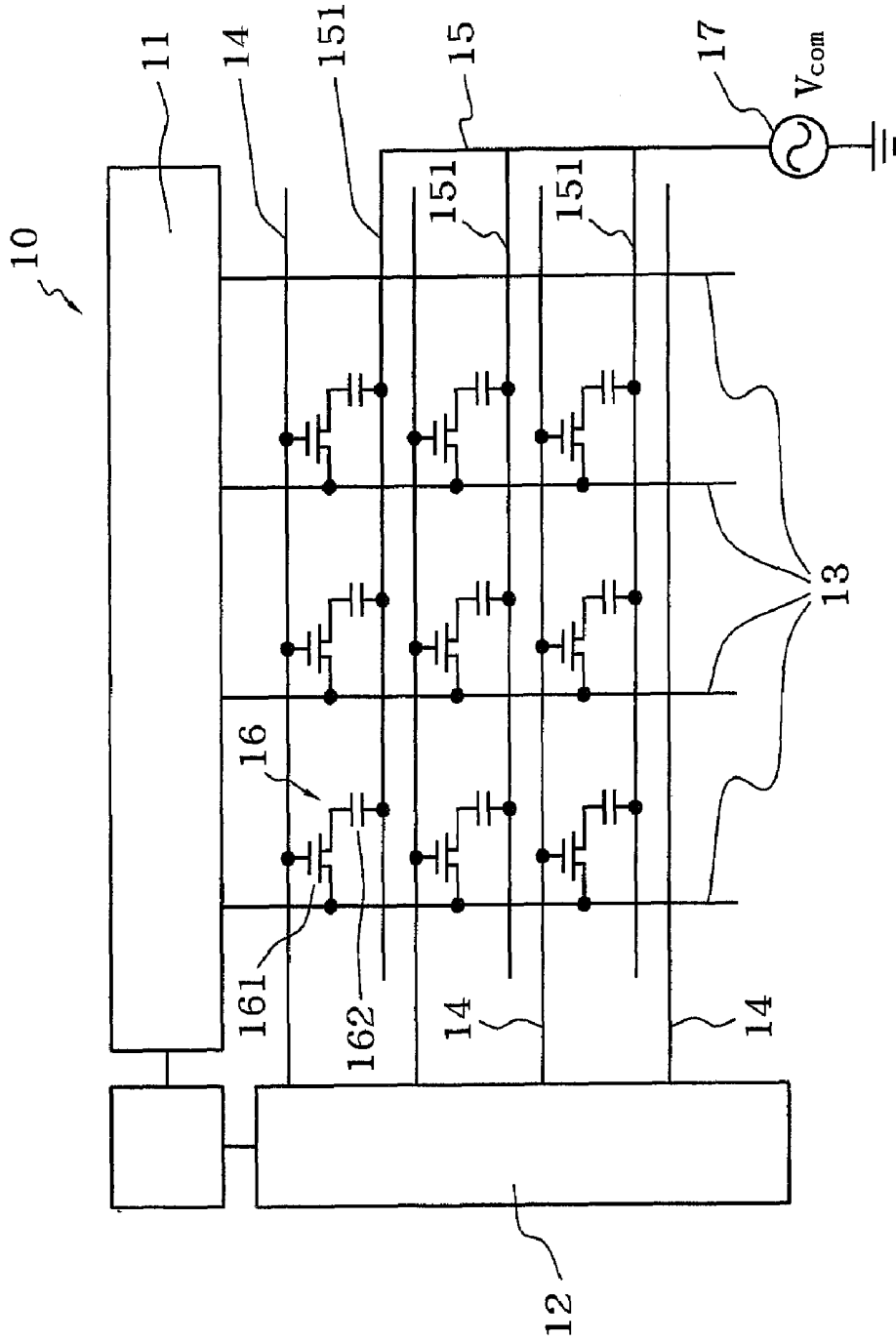

FIG. 1 (Background Art)

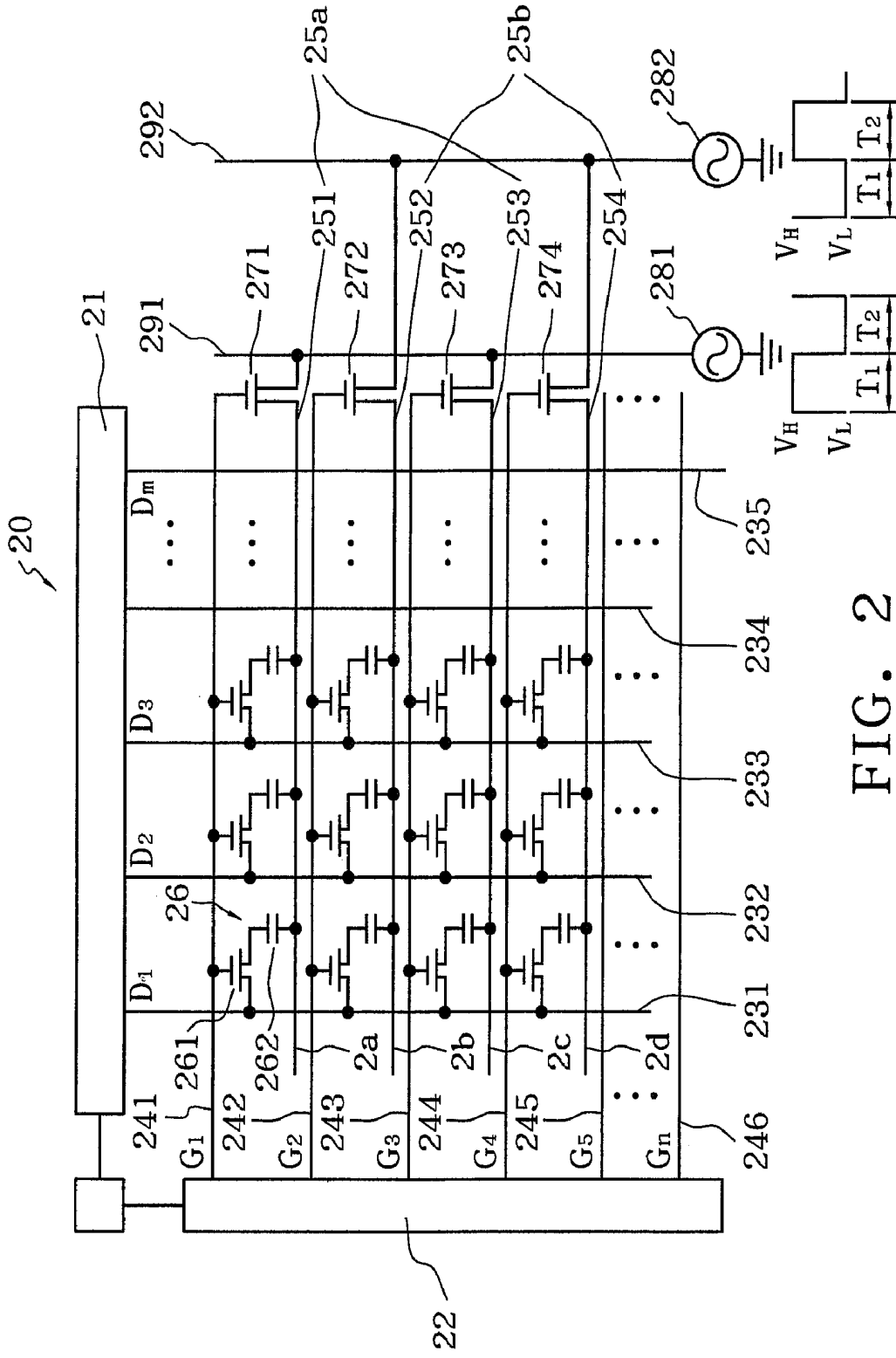

FIG. 2

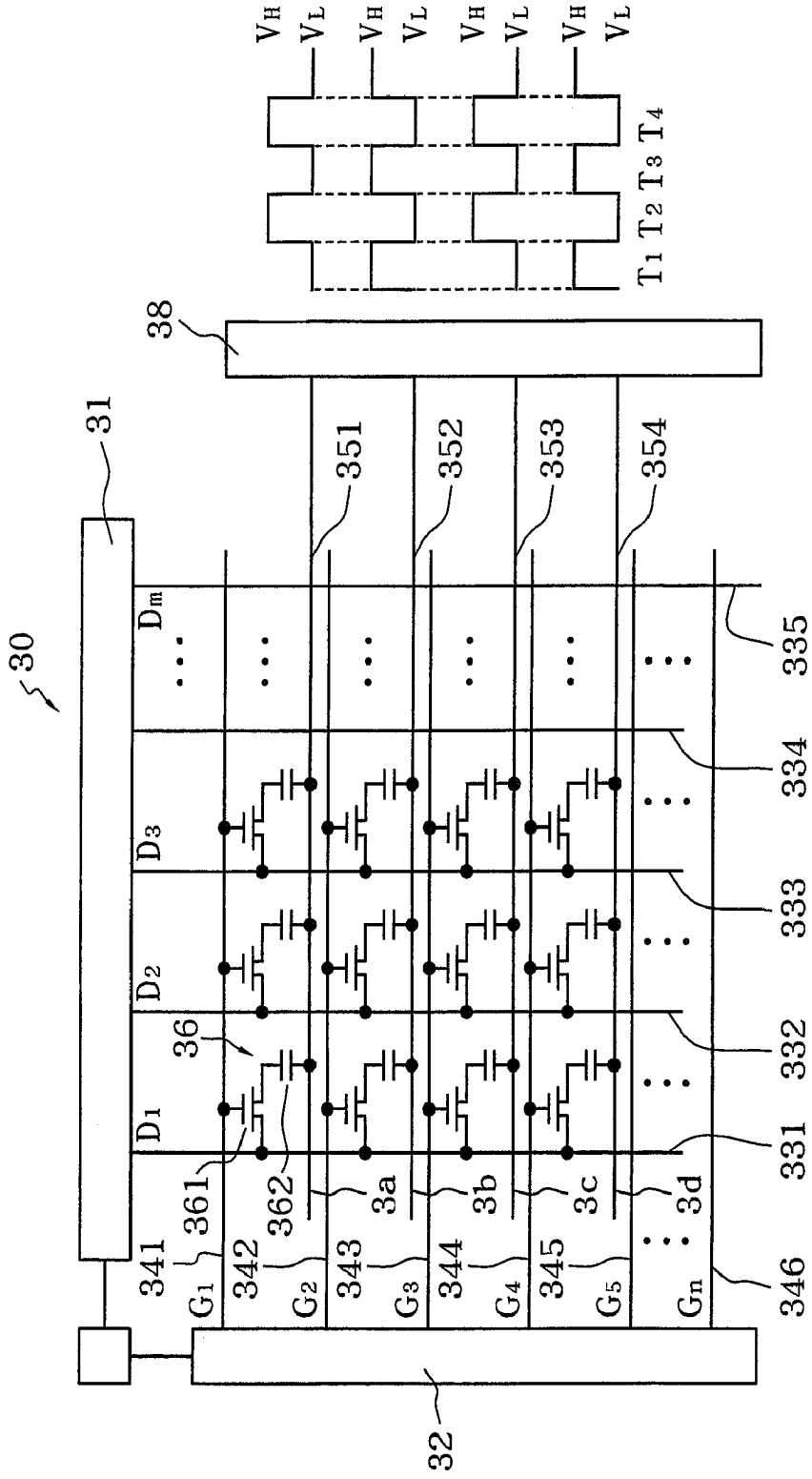

FIG. 3(a)

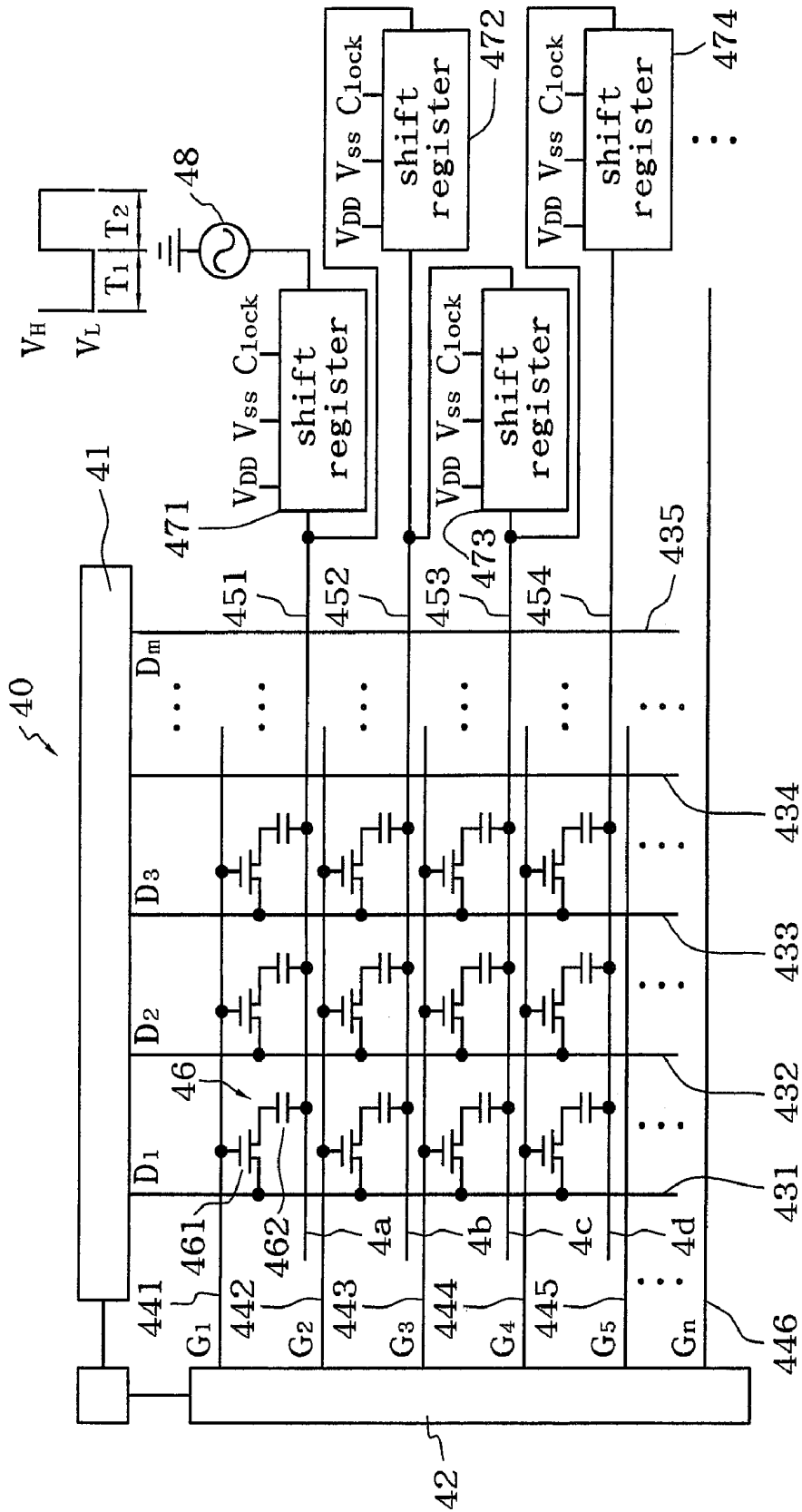

FIG. 4

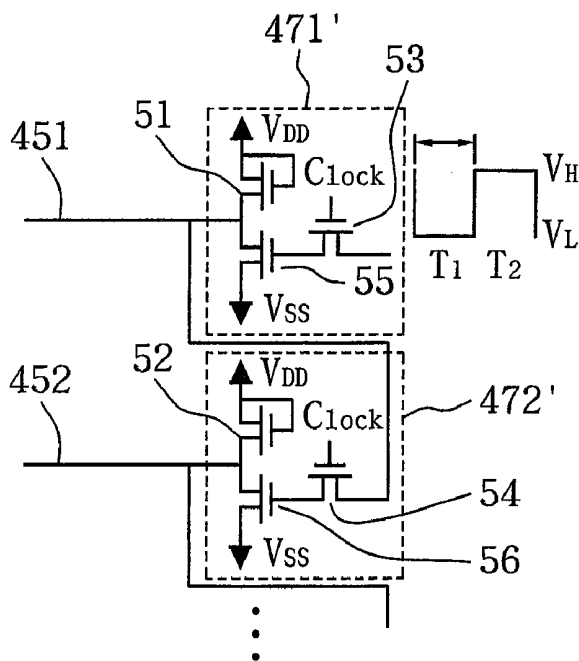

FIG. 5(a)

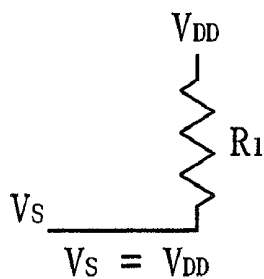

FIG. 5(b)

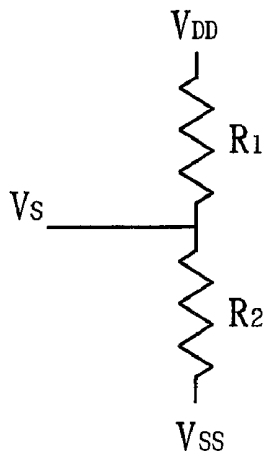

FIG. 5(c)

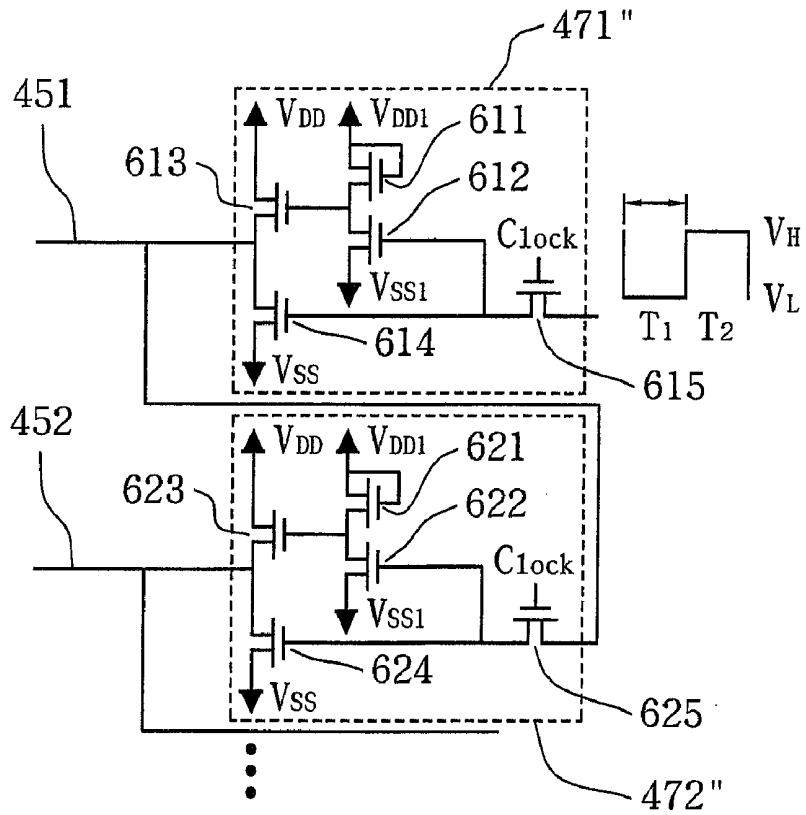

FIG. 6(a)

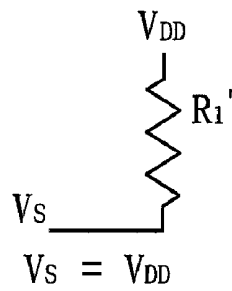

FIG. 6(b)

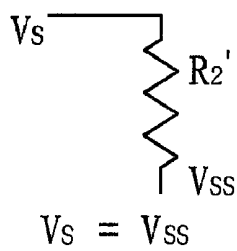

FIG. 6(c)

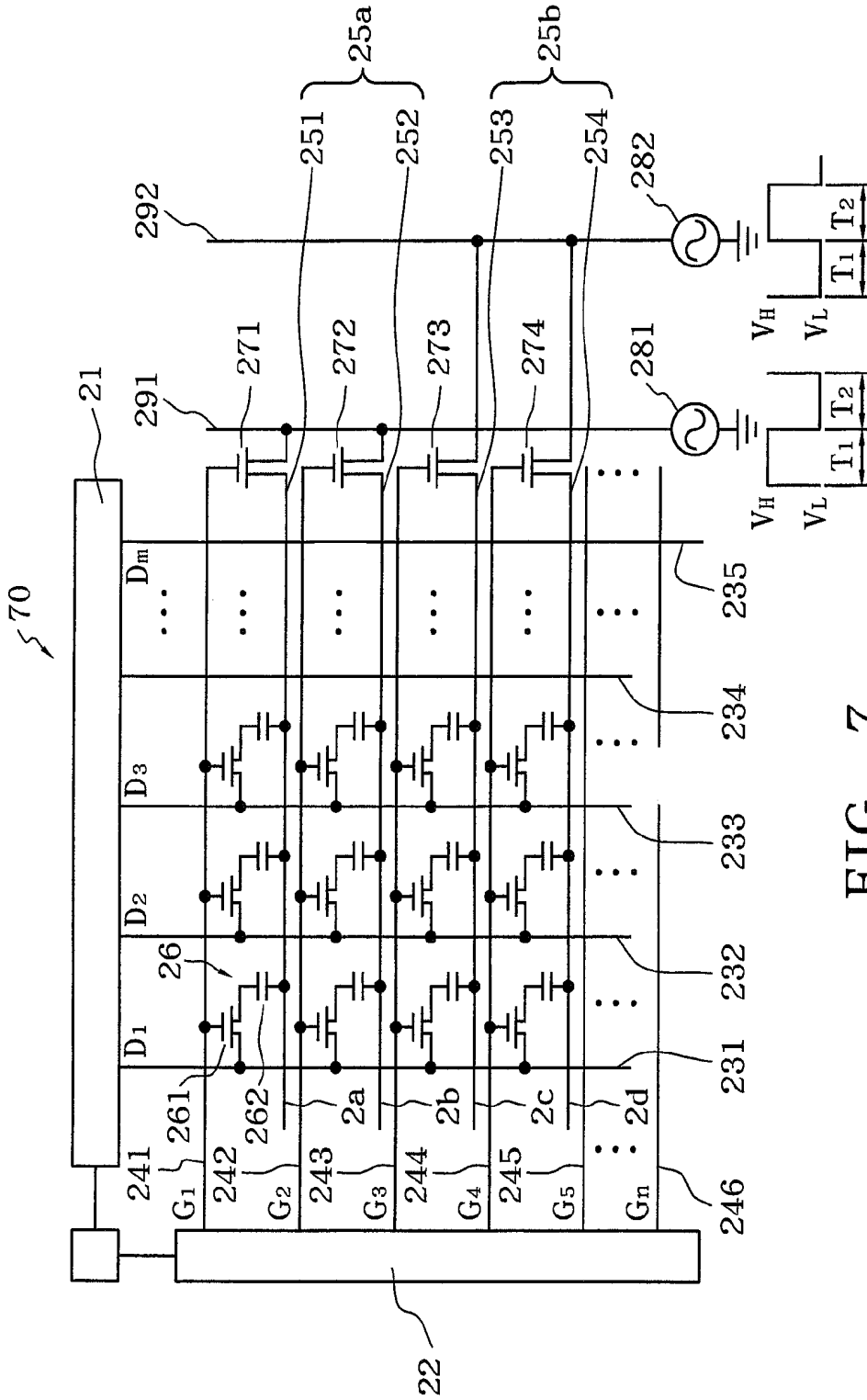

FIG. 7

LIQUID CRYSTAL DISPLAY

BACKGROUND OF THE INVENTION

1. Field of the Invention

The present invention relates to a liquid crystal display (LCD), and more particularly to an active matrix LCD rearranging the layout of its common electrode and modifying a corresponding driving method.

2. Description of the Related Art

The image quality of LCDs deteriorates due to a flicker phenomenon, which is directly relative to the sensitivity of the naked eye. Thin film transistor LCDs (TFT-LCDs) and super twisted nematic LCDs (STN-LCDs) are now generally used for display apparatuses. Unfortunately, both of them also have flicker problems. In most cases, to avoid flicker images, LCDs must be driven in an AC electrical field, because polarity inversion is needed. In LC cells, we find that flicker is mainly caused by the mobile ion charges, even though a higher frequency AC applied to the LC cells can reduce the flicker phenomenon. But power consumption is dependent on the frequency of the AC electrical field. On the other hand, due to a stray capacitor effect, the center level of driving signals shifts between two consecutive frame periods, so the amplitudes of the driving signals are different between the positive polarity and the negative polarity of the LC cells. Therefore, the flicker problem becomes worse.

FIG. 1 is an equivalent circuit diagram of a conventional LCD. The LCD 10 has a plurality of pixels 16 formed by a plurality of parallel data lines 13 perpendicularly crossing a plurality of parallel scanning lines 14. Each of the pixels 16 further includes a thin film transistor (TFT) 161 and an LC capacitor 162 that controls the rotation directions of LC molecules. The data lines 13 and scanning lines 14 respectively transmit driving signals generating from a data driver module 11 and scanning driver module 12, and the driving signals can drive each pixel 16 to have a proper gradation on its color. All the LC capacitors 162 electrically shorting to one of the scanning lines 14 are together electrically connected to a common electrode 151, and all the common electrodes 151 short to a principal common electrode 15 whose potential is driven by a modulation signal source 17.

Generally speaking, in the duration of polarity inversion, the potential of the common electrode 151 can synchronously vary with the variation of the potential of pixel electrodes so as to reduce the operating range of the potential for the pixel electrodes. For example, a 15 inch LCD having 1024×768 pixels execute polarity inversion by row inversion. The principal common electrode 15 needs to have its potential modulated once after each row of the pixels is scanned. We can assume that a vertical scanning frequency is 60 Hz, and the modulation signal source 17 must have a potential modulation frequency around 768×60=46,080 Hz. However, all the common electrodes 151 on the display also have to vary their potentials synchronously with the modulation frequency, thus too much electrical power would be wasted.

SUMMARY OF THE INVENTION

The first objective of the present invention is to provide a liquid crystal display whose common electrodes are grouped into several sets. The potential of each set is independently modulated by a different driving circuit. During a vertical scanning period, these driving circuits can separately or

non-synchronously modulate the potentials of these sets; hence modulation frequency and power consumption can be quite reduced.

The second objective of the present invention is to provide a liquid crystal display that can eliminate an image-sticking phenomenon so as to avoid the overlap of the images of two adjacent frames.

The third objective of the present invention is to provide a liquid crystal display that can eliminate the flicker phenomenon and reduce power consumption under a lower modulation frequency.

The fourth objective of the present invention is to provide a liquid crystal display that can shorten its response time and reduce the delay effect caused from the long transmission distance of electrical signals by separately or non-synchronously varying the potentials of the sets of common electrodes.

In order to achieve the objective, the present invention discloses a liquid crystal display that replaces the common electrodes of a conventional LCD with a plurality of switch electrodes. The plurality of switch electrodes is grouped into several switch electrode sets. Each of the switch electrode sets' potential is modulated by a different driving circuit. The driving circuits can also separately modulate the potentials of the switch electrode sets according to the scanning sequence of the LCD.

BRIEF DESCRIPTION OF THE DRAWINGS

The invention will be described according to the appended drawings in which:

FIG. 1 is an equivalent circuit diagram of a conventional LCD;

FIG. 2 is an equivalent circuit diagram of an LCD in accordance with the first embodiment of the present invention;

FIGS. 3(a)-3(b) is an equivalent circuit diagram of an LCD in accordance with the third embodiment of the present invention;

FIGS. 4 is an equivalent circuit diagram of an LCD in accordance with the fourth embodiment of the present invention;

FIG. 5(a) is a circuit diagram of the shift register in accordance with the fourth embodiment of the present invention;

FIGS. 5(b)-5(c) are equivalent circuit diagrams of the shift register in FIG. 5(a);

FIG. 6(a) is a further circuit diagram of the shift register in accordance with the fourth embodiment of the present invention;

FIGS. 6(b)-6(c) are equivalent circuit diagrams of the shift register in FIG. 6(a); and

FIG. 7 is an equivalent circuit diagram of an LCD in accordance with the second embodiment of the present invention.

PREFERRED EMBODIMENT OF THE PRESENT INVENTION

FIG. 2 is an equivalent circuit diagram of an LCD in accordance with the first embodiment of the present invention. The LCD 20 has a plurality of pixels 26 formed by a plurality of parallel data lines (D1-Dm) 231-235 perpendicularly crossing a plurality of parallel scanning lines (G1-Gn) 241-246. Each of the pixels 26 further includes a thin film transistor (TFT) 261 and an LC capacitor 262 that controls the rotation directions of LC molecules. The data

lines **231-235** transmit driving signals generated from a data driver module **21**, and the scanning lines **241-246** transmit driving signals generating from a scanning driver module **22**. When the gate electrode of the TFT **261** of the pixel **26** is selected by the scanning signals, the TFT (n channel) **261** is turned on and allows a data signal to write into a storage capacitor. In the LCD **20** as shown in FIG. **2**, all the LC capacitors **262** electrically shorting to a conductive line **2a** are together electrically connected to a switch electrode **251**, and their another terminals are respectively electrically shorts to their corresponding TFTs **261** of which gate electrodes are together electrically connected to the scanning lines **241**. The other switch electrodes **252-254** are separately and electrically connected to the LC capacitors **262** through the conductive lines **2b-2d**.

The side of the scanning line **241** that is opposite to a scanning driver module **22** is connected to the gate electrode of a transistor **271**, and the source electrode and drain electrode of the transistor **271** is respectively connected to a first principle switch electrode **291** and the switch electrode **251**. As shown in FIG. **2**, the transistor **271-274** are not only placed at the side opposite to the scanning driver module **22**, but also can be placed at the same or both side. A first signal source **281** applying to the first principle switch electrode **291** changes into a high potential VH during an interval T1; meanwhile, the scanning line **241** is selected to be at a high potential. Because the transistor **271** is turned on, the potential of the switch electrode **251** also changes into the same high potential VH. A next scanning line **242** adjacent to the scanning line **241** is connected to the gate electrode of a transistor **272**, and a switch electrode **252** on the same row of the pixels that is connected to the drain electrode of the transistor **272**. In addition, the source electrode of the transistor **272** is connected to a second principal switch electrode **292**, which a second signal source **282** supplies signals to. The first signal source **281** and the second signal source **282** have opposite phases. That is, during the interval T1, the first signal source **281** remains at the high potential VH, but the second signal source **282** is at the low potential VL. When the next interval T2 comes, the first signal source **281** changes into the low potential VL, and the second signal source **282** also changes into the high potential VH.

According to the above operating principle of the circuit, the switch electrodes **251**, **253**, etc., belong to a first switch electrode set **25a**, and all are connected to a first principal switch electrode **291**. The switch electrodes **252**, **254**, etc., belong to a second switch electrode set **25b**, and all are connected to a second principal switch electrode **292**. During the interval T1, the first switch electrode set **25a** remains at the high potential VH, but the second switch electrode set **25b** is at the low potential VL. On the contrary, when the interval comes, the first switch electrode set **25a** changes into the low potential VL, and the second switch electrode set **25b** changes into the high potential VH. This polarity inversion can be regarded as a type of row inversion under the interlacing scanning sequence. It is preferred that the intervals T1 and T2 are separately equal to the vertical scanning period, hence the modulation frequencies of the first signal source **281** and the second signal source **282** are the same as the vertical scanning frequency.

FIG. **7** is an equivalent circuit diagram of an LCD in accordance with the second embodiment of the present invention. In comparison with the first embodiment, this embodiment connects the first switch electrode set **25a** including the switch electrodes **251** and **252** to the first principal switch electrode **291** together, and connects the

second switch electrode set **25b** including the switch electrodes **253** and **254** to the second principal switch electrode **292** together.

FIGS. **3(a)** is an equivalent circuit diagram of an LCD in accordance with the third embodiment of the present invention. The LCD **30** has a plurality of pixels **36** formed by a plurality of parallel data lines (D1-Dm) **33-335** perpendicularly crossing a plurality of parallel scanning lines (G1-Gn) **341-346**. Each of the pixels **36** further includes a TFT **361** and an LC capacitor **362** that controls the rotation directions of LC molecules. The data lines **331-335** transmit driving signals generated from a data driver module **31**, and the scanning lines **341-346** respectively transmit driving signals generated from a scanning driver module **32**. In the LCD **30** as shown in FIG. **3(a)** all the LC capacitors **362** electrically shorting to a conductive line **3a** are together electrically connected to a switch electrode **351**, and their another terminals are respectively electrically shorts to their corresponding TFTs **361** of which gate electrodes are together electrically connected to the scanning lines **341**. The other switch electrodes **352-354** are separately and electrically connected to the LC capacitors **362** through the conductive lines **3b-3d**.

In comparison with the first embodiment, the present embodiment discloses that the switch electrodes **351-354** are all connected to a potential modulation module **38**. The potential modulation module **38** composed of a plurality of IC components can modulate the potentials of its output signals so as to separately control the potentials of the switch electrodes **351-354**. Therefore, more complex polarity inversion can be executed under the disclosure of the present embodiment. As shown in FIG. **3(a)**, the potential modulation module **38** outputs a square pulse as a potential modulation signal to each of the switch electrodes **351-354**, and the potential modulation signals applied to any two adjacent switch electrodes have reverse phases on their waveforms. Furthermore, as shown in FIG. **3(b)**, a switch electrode set is composed of the switch electrodes **351** and **352**, and another switch electrode set is composed of the switch electrodes **353** and **354**. The potential modulation module **38** outputs two potential modulation signals having reverse phases separately to aforesaid two adjacent switch electrode sets.

FIGS. **4** is an equivalent circuit diagram of an LCD in accordance with the fourth embodiment of the present invention. The LCD **40** has a plurality of pixels **36** formed by a plurality of parallel data lines (D1-Dm) **431-435** perpendicularly crossing a plurality of parallel scanning lines (G1-Gn) **441-446**. Each of the pixels **36** further includes a TFT **461** and an LC capacitor **462** that controls the rotational direction of the LC molecules. The data lines **431-435** transmit driving signals generated from a data driver module **41**, and the scanning lines **441-446** respectively transmit driving signals generated from a scanning driver module **42**. All the LC capacitors **462** electrically shorting to a conductive line **4a** are together electrically connected to a switch electrode **451**, and their another terminals are respectively electrically shorts to their corresponding TFTs **461** of which gate electrodes are together electrically connected to the scanning lines **441**. The other switch electrodes **452-454** are separately and electrically connected to the LC capacitors **462** through the conductive lines **4b-4d**.

In comparison with the first embodiment, the present embodiment replaces the transistors **271-274**, respectively, with shift registers **471-474** and provides only one signal source **48** to generate a modulating signal. The output

voltage of a shift register **471** is applied to a shift register **472** as an input voltage. In the same way, the output pin of a previous shift register shorts to the input pin of a next shift register. Each shift register further comprises three pins, namely V_{DD} , V_{SS} and clock pins. The shift register is enabled while the clock pin is selected. The signal source **48** pulls down at a low potential VL during an interval T1, meanwhile the shift register **471** outputs a high potential VSH its clock pin is selected. During a next interval T2, the signal source **48** pulls up to a high potential VH, meanwhile the shift register **471** outputs a low potential VSL. Since the output pin of the shift register **471** cascades with the input pin of the shift register **472**, the switch electrode **451** remains at a high potential VSH during the interval T1, but the switch electrode **452** is at a low potential VSL. In the same way, if the clock pin of each the shift register shorts to each scanning line on the same pixel row, the switch electrode **451** and **453** are all at the same potential level, and the switch electrode **452** and **454** are all also at the same potential level. In other words, the switch electrodes of the odd pixel rows and the even pixel rows have opposite phases of their potentials.

FIG. **5(a)** is a circuit diagram of the shift register in accordance with the fourth embodiment of the present invention. A shift register **471'** is composed of three transistors **51**, **53** and **55**, wherein transistors **51** and **55** can act as an inverter. The gate electrode of the transistor **53** can be turned on by a clock signal, and square pulses generated from the signal source **48** applies to its source electrode. The gate electrode of the transistor **55** is coupled to the drain electrode of the transistor **53**. The source electrode of the transistor **51** is coupled to the V_{DD} pin, and the source electrode of the transistor **55** is coupled to the V_{SS} pin.

During an interval T1, a low potential VL is applied to the source electrode of the transistor **53**, meanwhile the potential V_S of the switch electrode **451** remains at a high potential V_{DD} and the scanning signal on the scanning line **441** is applied to the clock pin to enable the shift register **471'**. Under the above conditions, FIG. **5(a)** can be simplified as the equivalent circuit of FIG. **5(b)**. Because the gate electrode of the transistor **55** is at a low potential VL, the transistor **55** is turned off to be an open node. But the transistor **51** is always turned on to enable the switch electrode **451** to short to V_{DD} . During an interval T2, the signal source **48** switches the gate electrode of the transistor **55** to a high potential VH so as to turn on the transistor **55**. Meanwhile, the potential of the switch electrode **451** is proportional to the ratio of an internal resistance R1 to an internal resistance R2, as shown in FIG. **5(c)**, an equivalent circuit of FIG. **5(a)**. The potential of the switch electrode **451** is given by the following formula:

$$V_S = V_{SS} + (V_{DD} - V_{SS}) \times \frac{R1}{R1 + R2};$$

wherein the potential V_S of the switch electrode **451** approximates V_{SS} when the internal resistance R1 is a relative large value in comparison with the value of the internal resistance R2.

A shift register **472'** is also composed of three transistors **52**, **54** and **56**, whose circuit topology is the same as the shift register **471'**. The output voltage of the shift register **471'** is coupled to the source electrode of the transistor **54** as the input voltage of the shift register **472'**. When the scanning line of the second pixel row is selected, the scanning signal

can turn on the shift register **472'**. The output voltages of the shift register **471'** and **472'** are opposite to each other.

In general cases, the inner resistance of the amorphous silicon channel of a transistor is not controlled due to process variation. FIG. **6(a)** shows a modified circuit of a shift register to overcome the shift problem of the output voltage in FIG. **5(a)**. A shift register **471''** is composed of five transistors **611**, **612**, **613**, **614** and **615**, wherein the transistors **611** and **612** can act as an inverter. During the interval T1, the signal source **48** switches to a low potential VL, and the transistor **613** is turned on because a high potential is applied to its gate electrode. The transistor **614** to whose gate electrode is applied a low potential VL is at an off status, hence the potential V_S of the switch electrode **451** remains at a high potential V_{DD} during the interval T1. Under the above conditions, FIG. **6(a)** can be simplified as the equivalent circuit of FIG. **6(b)** wherein R1' represents the internal resistance of the transistor **613**. During the interval T2, the signal source **48** switches to a high potential VH, and the transistor **613** whose gate electrode is applied a low potential is at an off status. On the other hand, the transistor **614** to whose gate electrode is applied a high potential VH is at an on status, hence the potential V_S of the switch electrode **451** remains at the low potential V_{SS} . FIG. **6(a)** also can be simplified as the equivalent circuit of FIG. **6(c)** wherein R2' represents the internal resistance of transistor **614**.

The above-described embodiments of the present invention are intended to be illustrative only. Numerous alternative embodiments may be devised by persons skilled in the art without departing from the scope of the following claims.

What is claimed is:

1. A liquid crystal display, comprising:

- a plurality of data lines;
 - a plurality of scanning lines and a plurality of conductive lines crossing the plurality of data lines; and
 - a plurality of pixels positioned at a plurality of matrix-arranged unit areas enclosed by the scanning lines and the data lines, each of the plurality of pixels including a thin film transistor and a liquid crystal capacitor;
- wherein a plurality of first conductive lines among the conductive lines is respectively modulated relative to a plurality of second conductive lines among the conductive lines, and wherein the modulation frequency thereof is synchronized with a scanning frequency of the plurality of scanning lines.

2. The liquid crystal display of claim 1, wherein the plurality of first conductive lines among the conductive lines are respectively coupled to at least one first transistor, and the plurality of second conductive lines among the conductive lines are respectively coupled to at least one second transistor.

3. The liquid crystal display of claim 2, wherein each of the first and second transistors has a gate electrode electrically connected to one of the scanning lines, a source electrode electrically connected to the plurality of first conductive lines or the plurality of second conductive lines, and a drain electrode electrically connected to a modulation signal source.

4. The liquid crystal display of claim 3, wherein the drain electrodes of the first transistors are connected to a first modulation signal source, and the drain electrodes of the second electrodes are connected to a second modulation signal source.

5. The liquid crystal display of claim 4, wherein the first modulation signal source and the second modulation signal source separately output square pulses as potential modulation signals opposite in phase.

7

6. The liquid crystal display of claim 1, further comprising a potential modulation module electrically connected to the first and the second conductive lines.

7. The liquid crystal display of claim 6, wherein the potential modulation module outputs square pulses as potential modulation signals to the first and second conductive lines, and the potential modulation signals respectively applied to two adjacent first and second conductive lines are opposite in phase.

8. The liquid crystal display of claim 1, wherein each of the first conductive lines is electrically connected to a first shift register, and each of the second conductive lines is electrically connected to a second shift register.

9. The liquid crystal display of claim 8, further comprising a modulation signal source electrically connected to one of the first shift registers.

10. The liquid crystal display of claim 9, wherein the one of the first shift registers shorts to the first conductive line at the first row.

11. The liquid crystal display of claim 10, wherein each of the first and second shift registers has a first potential pin

8

shorting to a first external potential source, a second potential pin shorting to a second external potential source, and a clock pin shorting to the corresponding scanning line.

12. The liquid crystal display of claim 11, wherein the output terminal of each of the first and second shift registers is at a first potential when the clock pin is selected by the scanning line and meanwhile the input terminal of each of the first and second shift registers is at a second potential.

13. The liquid crystal display of claim 9, wherein an output terminal of the first shift register at the first row is connected to an input terminal of the second shift register next to the first shift register.

14. The liquid crystal display of claim 1, wherein the first conductive lines and the second conductive lines are positioned alternatively to each other.

15. The liquid crystal display of claim 1, wherein the set of the first conductive lines are positioned adjacent to the set of the second conductive lines.

* * * * *

专利名称(译)	液晶显示器		
公开(公告)号	US7321355	公开(公告)日	2008-01-22
申请号	US10/777164	申请日	2004-02-13
[标]申请(专利权)人(译)	LEE SEOK LYUL SHIH宝胜		
申请(专利权)人(译)	LEE SEOK LYUL SHIH宝胜		
当前申请(专利权)人(译)	瀚宇彩晶股份有限公司		
[标]发明人	LEE SEOK LYUL SHIH PO SHENG		
发明人	LEE, SEOK LYUL SHIH, PO SHENG		
IPC分类号	G09G3/36 G02F1/13		
CPC分类号	G09G3/3655 G09G3/3614 G09G2330/021 G09G2320/0247		
优先权	092105061 2003-03-07 TW		
其他公开文献	US20040196241A1		
外部链接	Espacenet USPTO		

摘要(译)

液晶显示器用多个开关电极代替传统LCD的公共电极。多个开关电极被分组为多个开关电极组。每个开关电极组的电位由不同的驱动电路调制。驱动电路还可以根据LCD的扫描顺序分别调制开关电极组的电位。

