



US006765642B2

(12) **United States Patent**
Lee

(10) **Patent No.:** **US 6,765,642 B2**
(45) **Date of Patent:** **Jul. 20, 2004**

(54) **IN-PLANE SWITCHING LIQUID CRYSTAL DISPLAY WITH A COMPENSATION ELECTRODE STRUCTURE AND METHOD OF FORMING THE SAME**

(75) **Inventor:** **Deuk Su Lee, Taoyuan Hsien (TW)**
(73) **Assignee:** **Hannstar Display Corp., Taipei (TW)**
(*) **Notice:** Subject to any disclaimer, the term of this patent is extended or adjusted under 35 U.S.C. 154(b) by 113 days.

(21) **Appl. No.:** **10/245,336**

(22) **Filed:** **Sep. 18, 2002**

(65) **Prior Publication Data**

US 2004/0051834 A1 Mar. 18, 2004

(51) **Int. Cl.⁷** **G02F 1/1343**

(52) **U.S. Cl.** **349/141**

(58) **Field of Search** 349/141

(56) **References Cited**

U.S. PATENT DOCUMENTS

6,628,360 B2 * 9/2003 Yamada et al. 349/132

* cited by examiner

Primary Examiner—Robert H. Kim

Assistant Examiner—Jeanne Andrea Di Grazio

(74) *Attorney, Agent, or Firm*—Rabin & Berdo, P.C.

(57) **ABSTRACT**

An IPS-LCD having a compensation electrode structure. In each pixel area, at least two common electrodes extending in a first Y-direction and at least one pixel electrode extending in a second Y-direction are inter-digitated with each other. Also, at least two compensation electrodes extending in the Y-direction are patterned on the same plane with the pixel electrode, and overlap the two common electrodes, respectively. A first interval between the first compensation electrode and pixel electrode is equal to a second interval between the pixel electrode and the second compensation electrode.

22 Claims, 16 Drawing Sheets

36

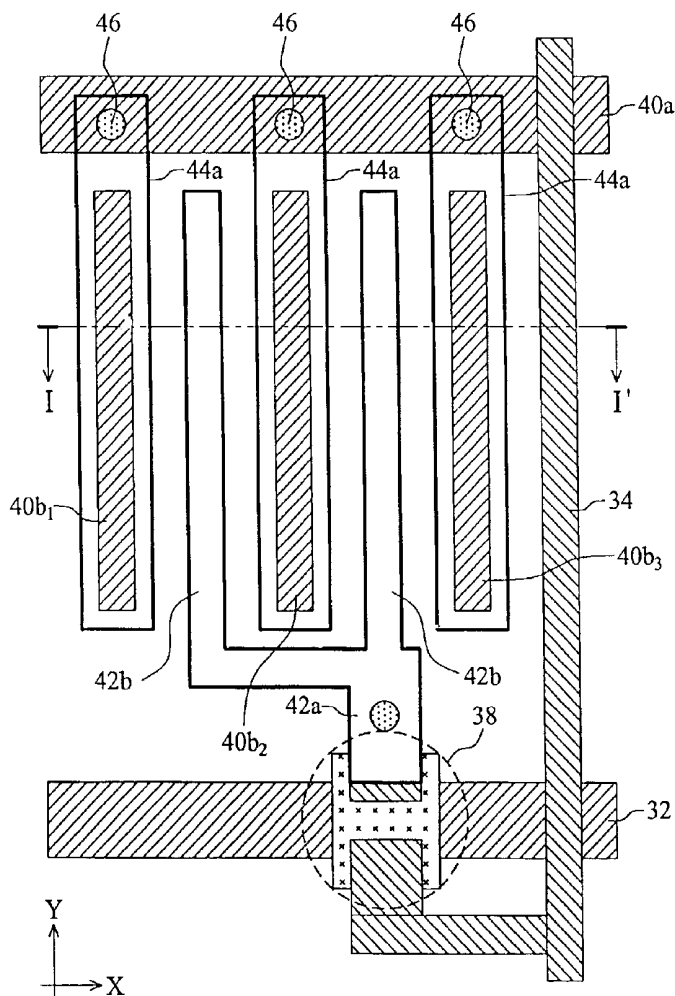

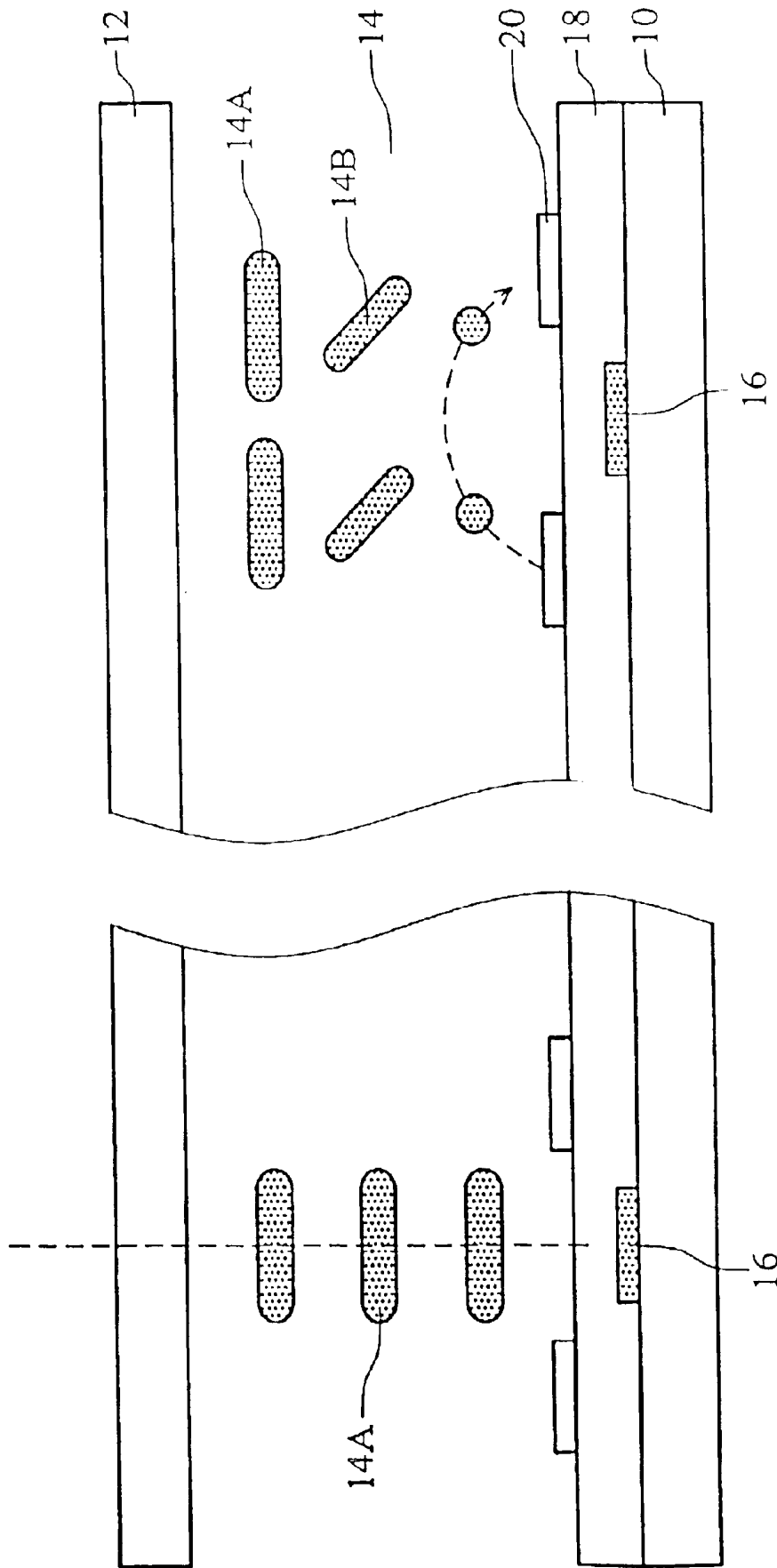

FIG. 1A (PRIOR ART) FIG. 1B (PRIOR ART)

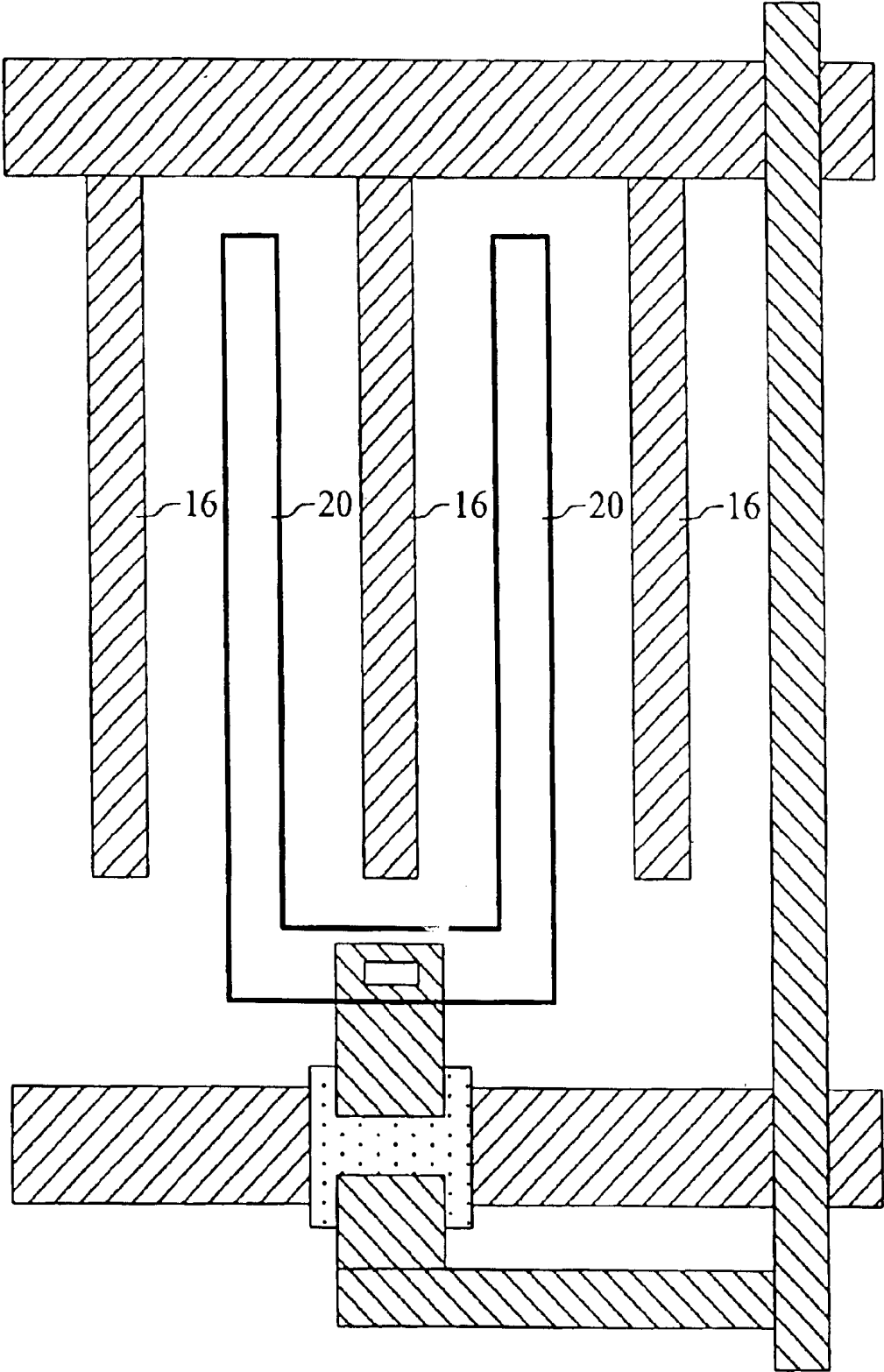

FIG. 1C (PRIOR ART)

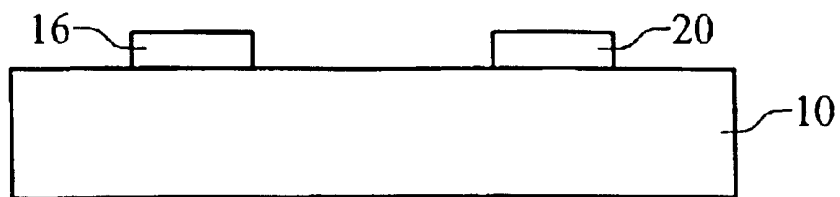

FIG. 2A (PRIOR ART)

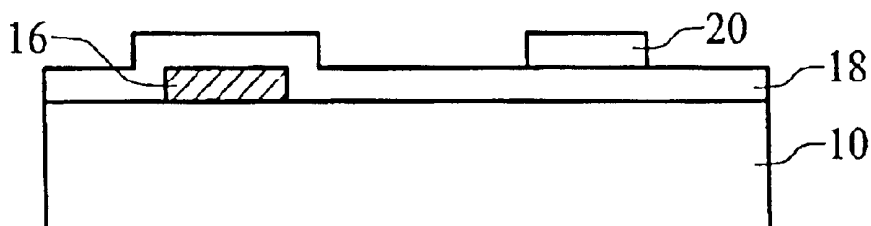

FIG. 2B (PRIOR ART)

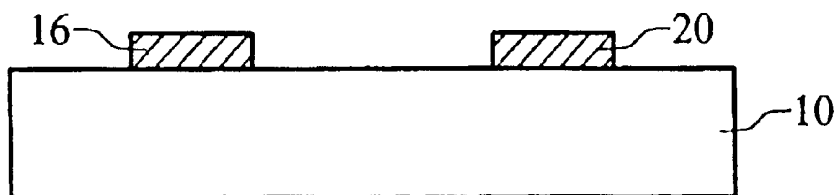

FIG. 2C (PRIOR ART)

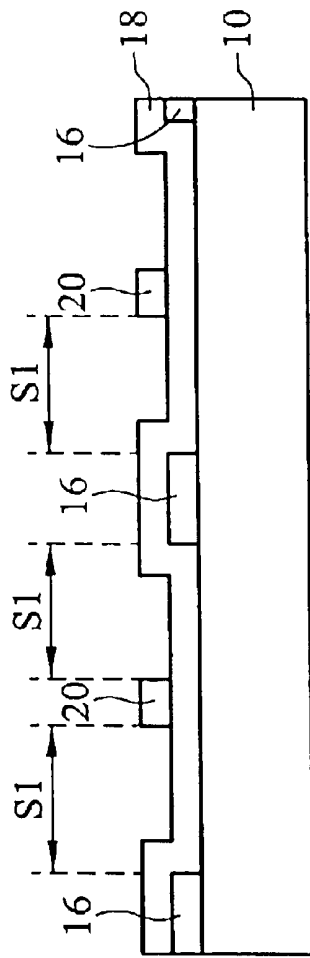

FIG. 3A (PRIOR ART)

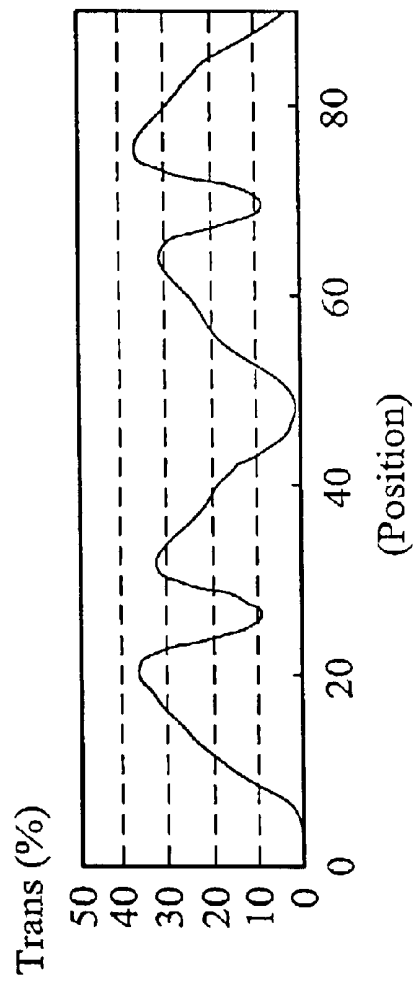

FIG. 3B (PRIOR ART)

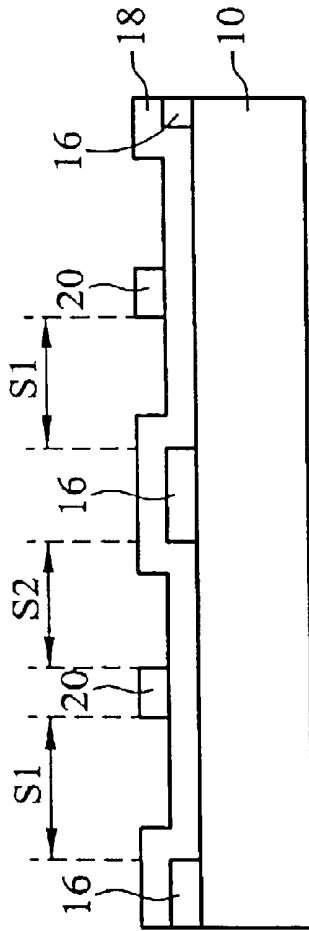

FIG. 4A (PRIOR ART)

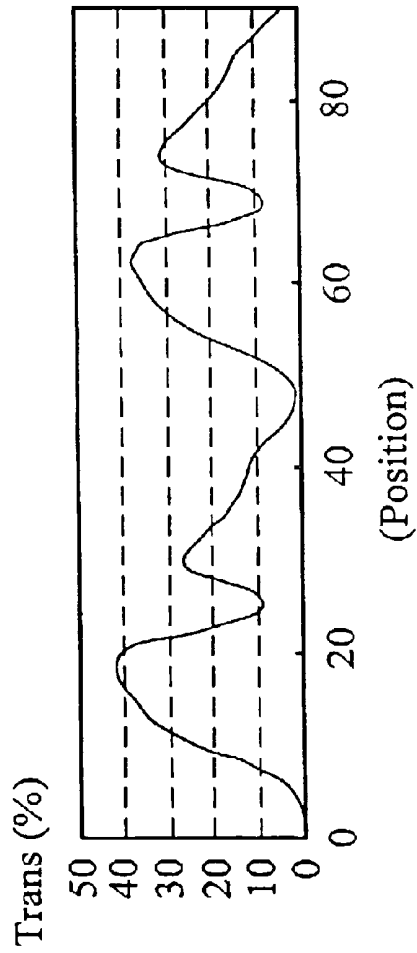

FIG. 4B (PRIOR ART)

36

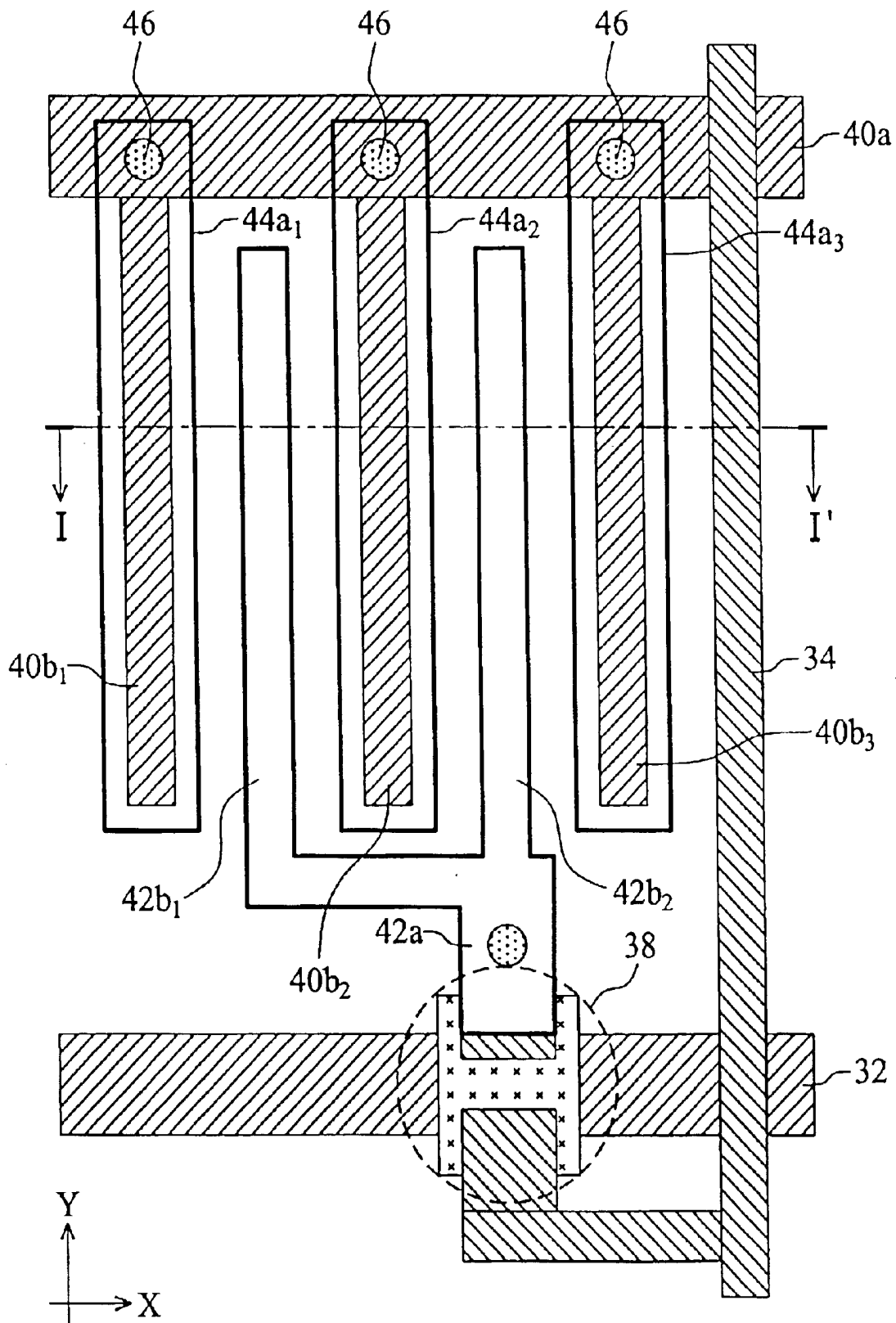

FIG. 5A

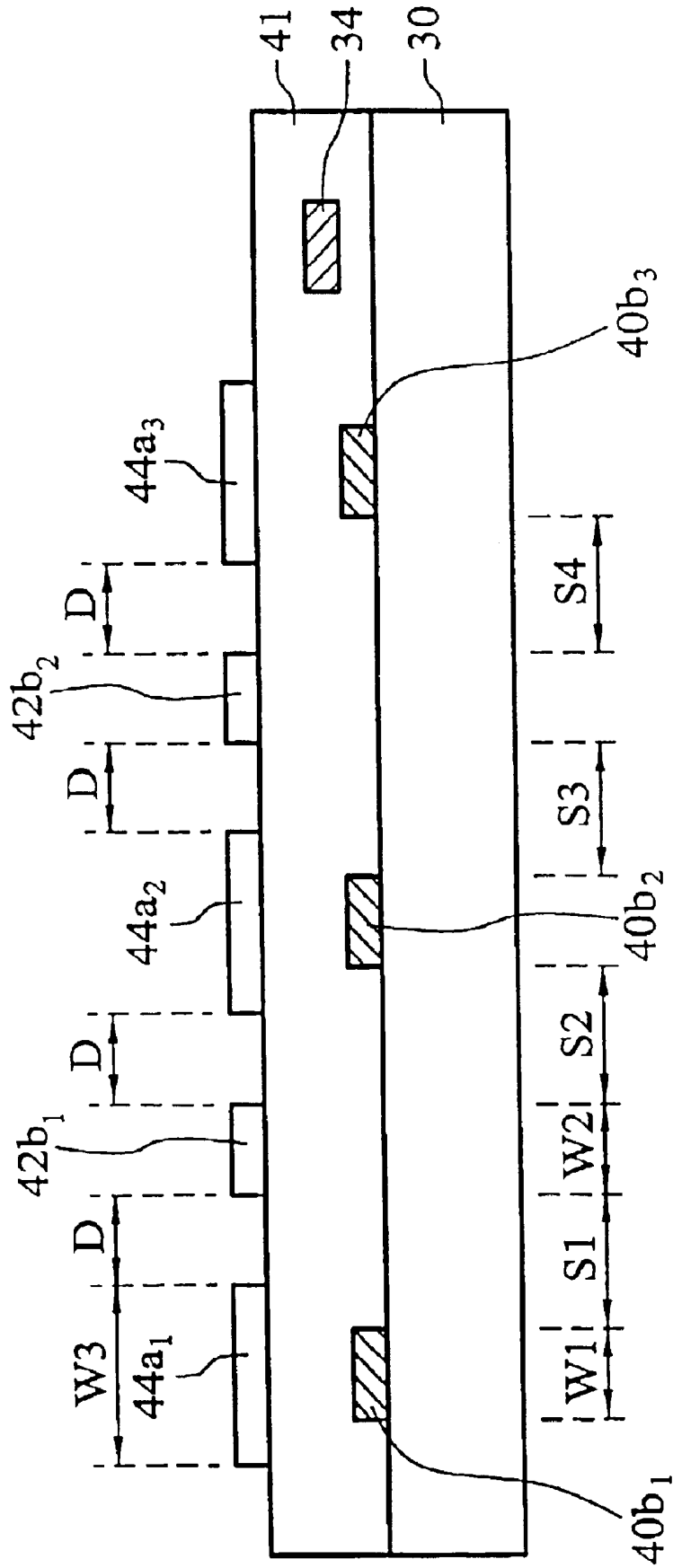

FIG. 5B

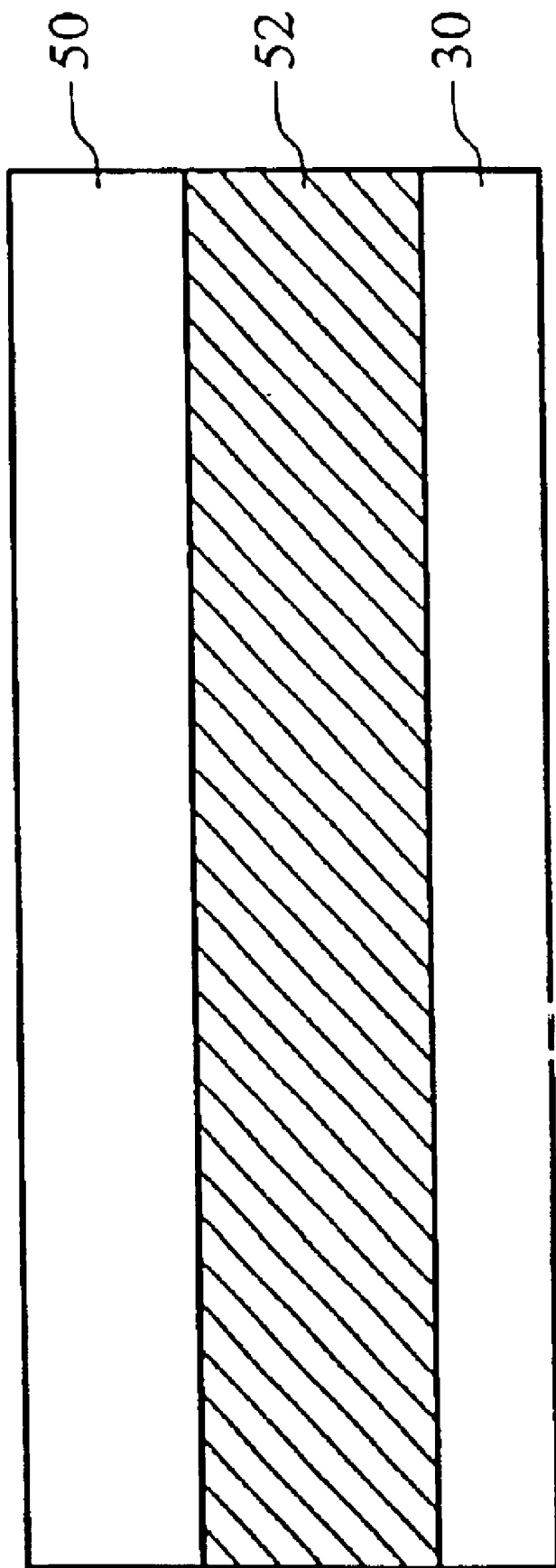

FIG. 5C

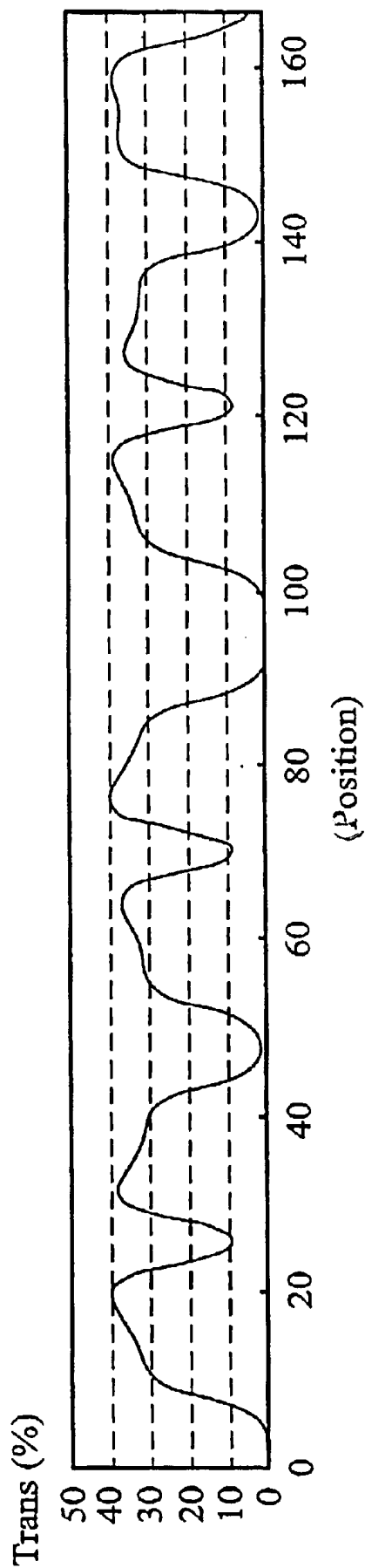

FIG. 6

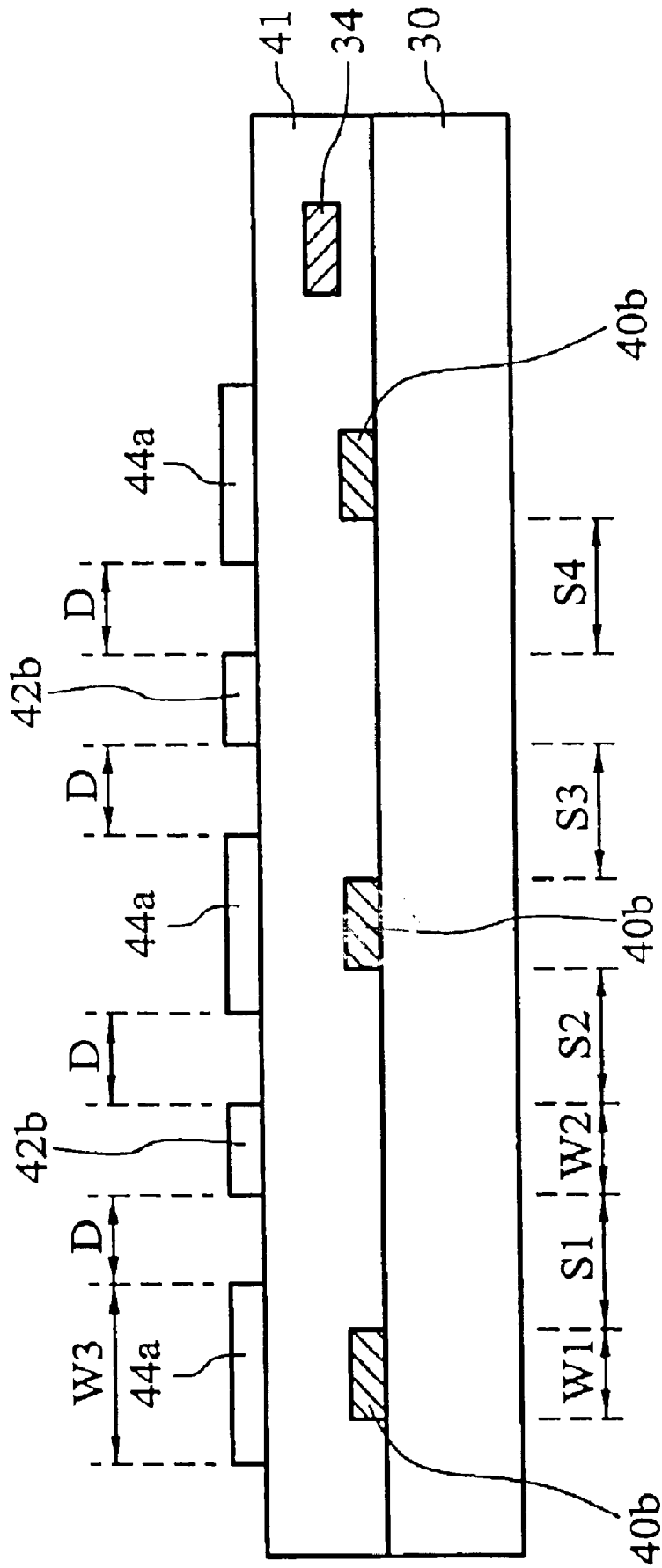

FIG. 7A

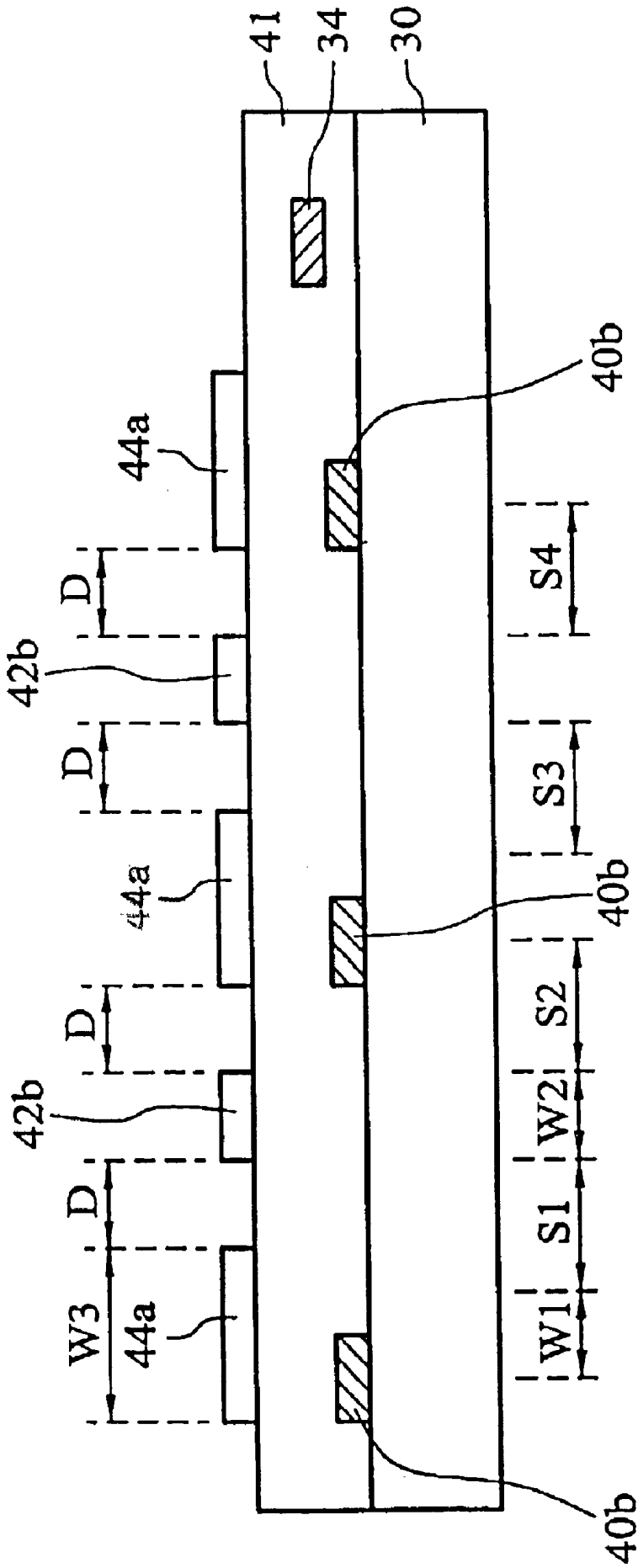

FIG. 7B

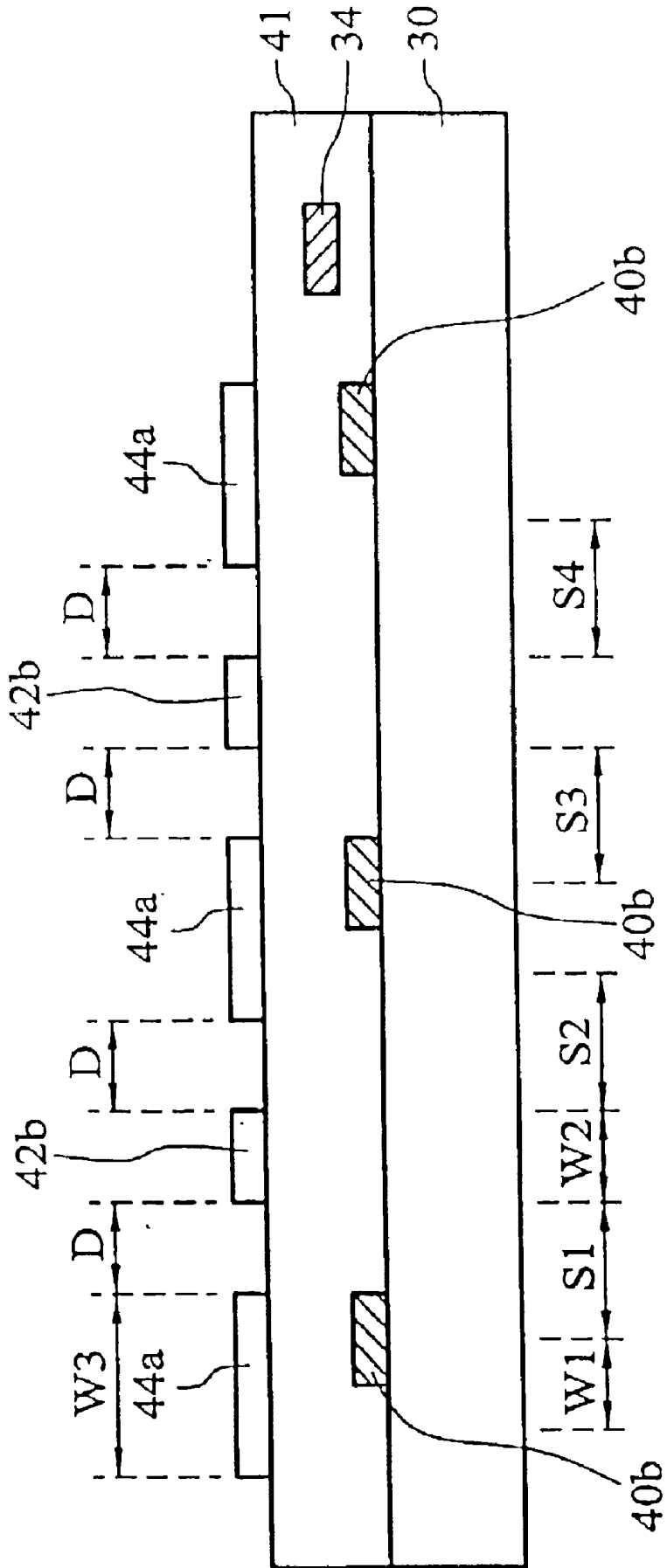

FIG. 7C

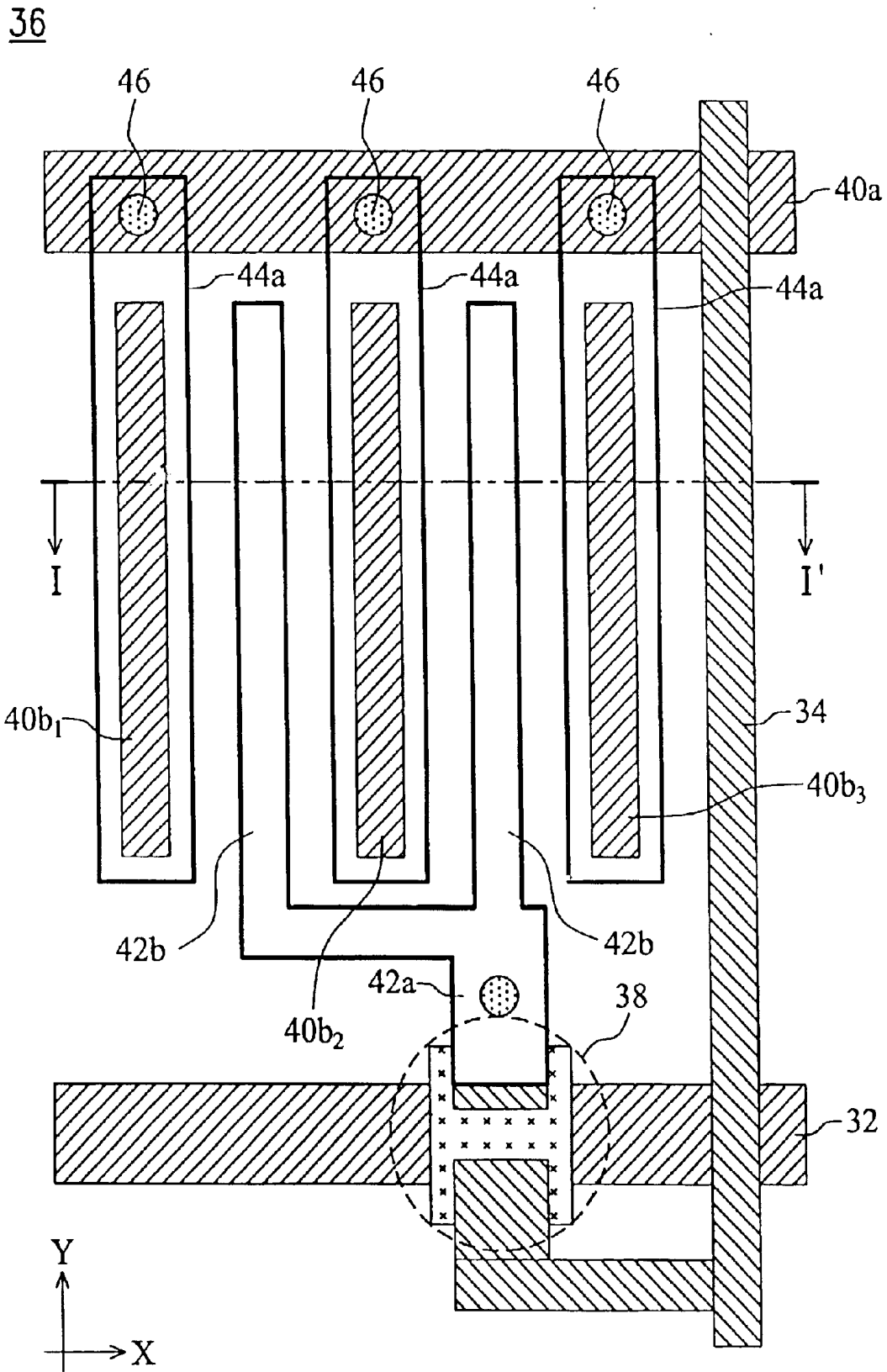

FIG. 8A

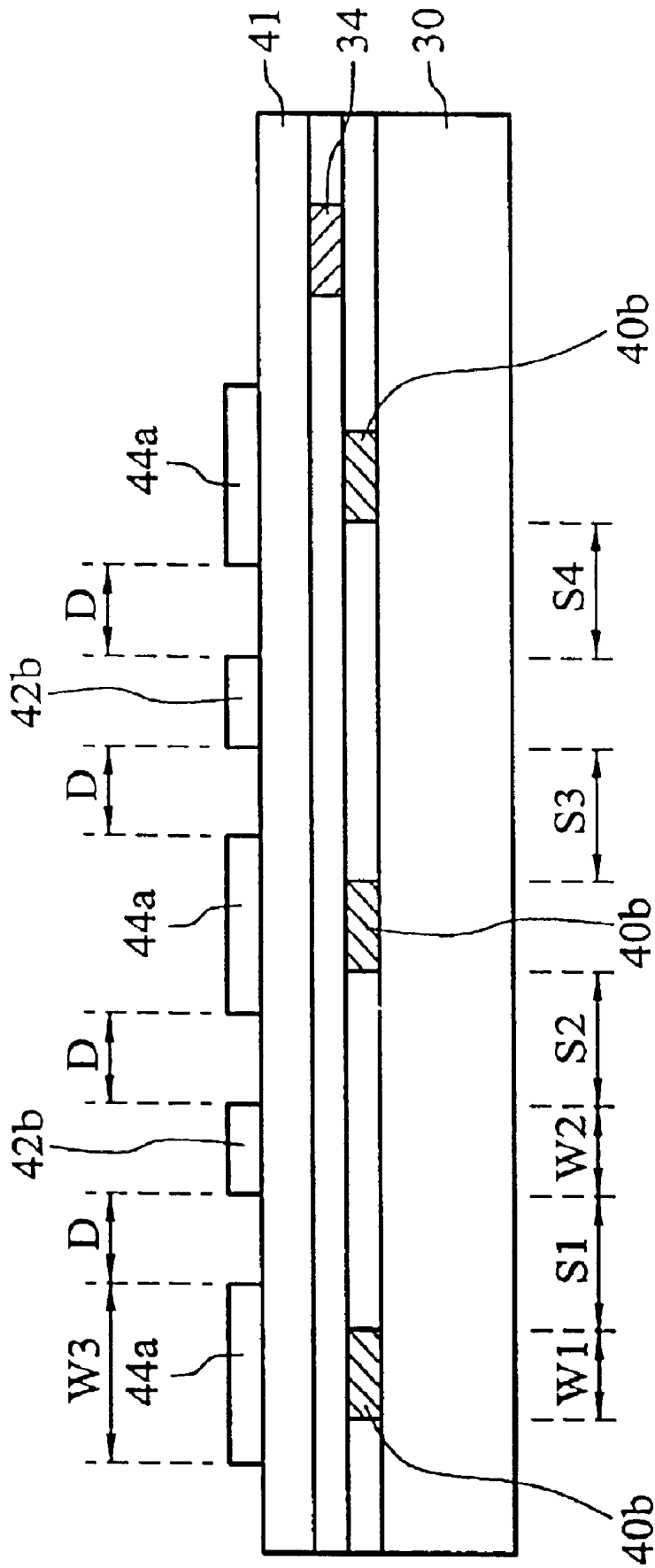

FIG. 8B

36

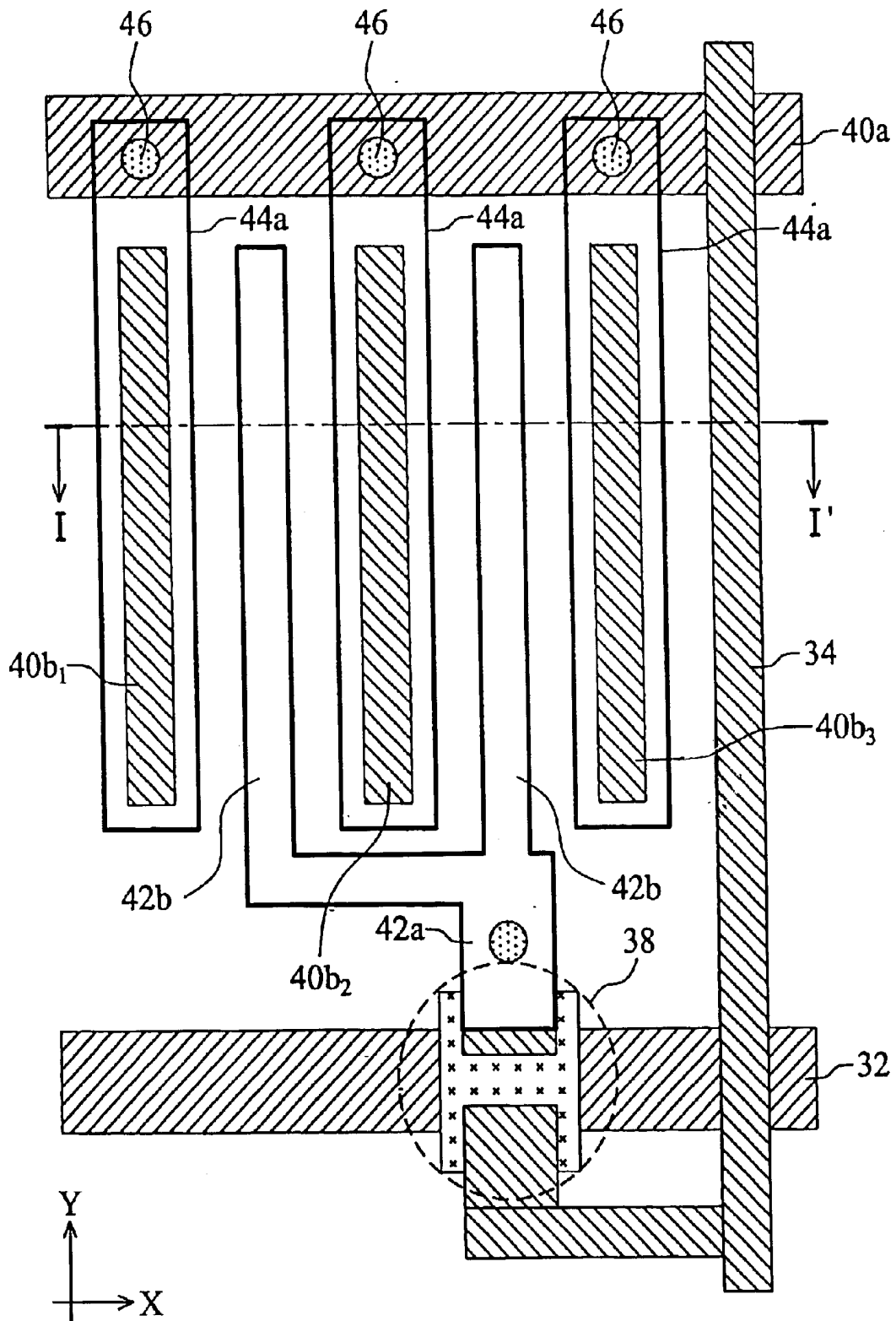

FIG. 9A

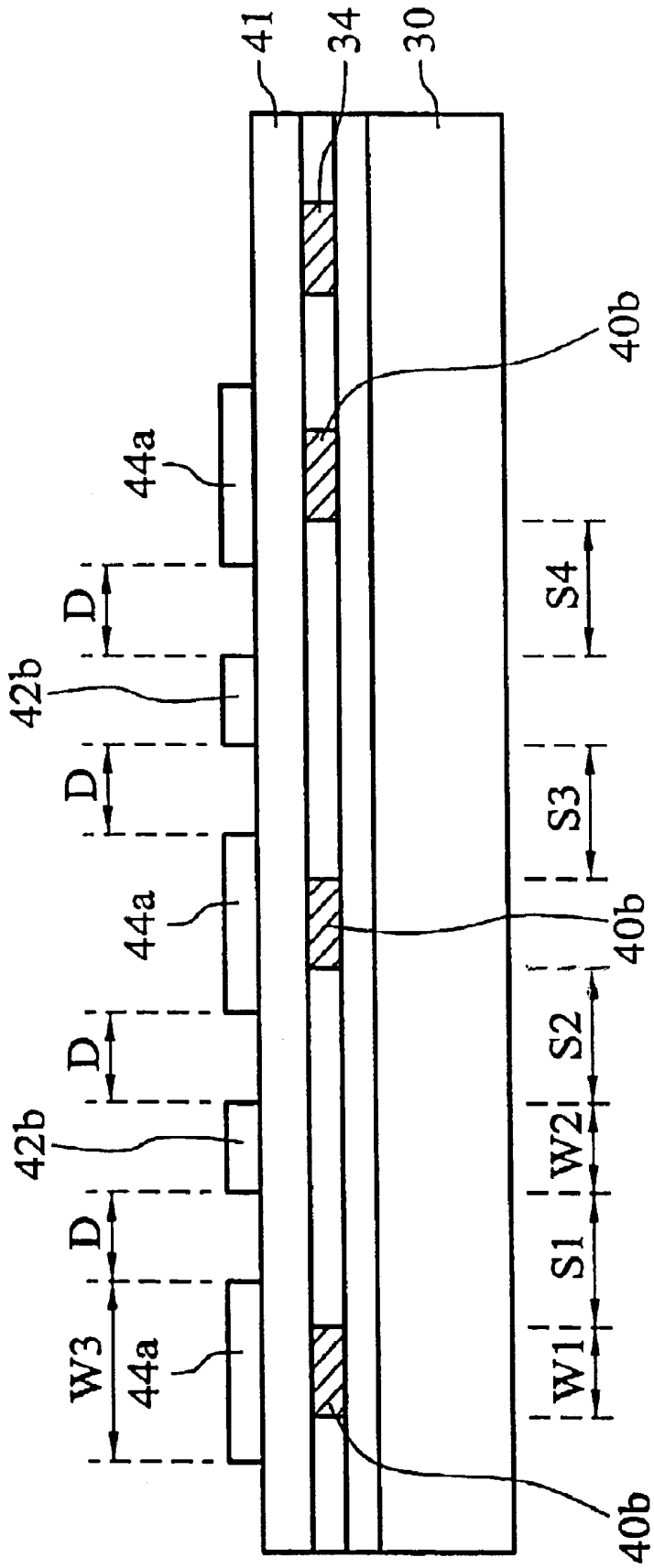

FIG. 9B

IN-PLANE SWITCHING LIQUID CRYSTAL DISPLAY WITH A COMPENSATION ELECTRODE STRUCTURE AND METHOD OF FORMING THE SAME

BACKGROUND OF THE INVENTION

1. Field of the Invention

The present invention relates in general to an in-plane switching liquid crystal display (IPS-LCD). In particular, the present invention relates to an IPS-LCD with a compensation electrode structure and a method of forming the same.

2. Description of the Related Art

Liquid crystal displays (LCDs) may be classified by the orientation of the liquid crystal molecules between the spaced apart glass substrates. In a conventional twisted nematic LCD (TN-LCD), the liquid crystal molecules are twisted between the two substrates. In contrast, in an in-plane switching LCD (IPS-LCD), common electrodes and pixel electrodes are formed on a lower glass substrate (TFT substrate) and an in-plane electric field therebetween is generated to rearrange the liquid crystal molecules along the electric field. Accordingly, the IPS-LCD has been used or suggested for improving drawbacks of the conventional TN-LCD, such as a very narrow viewing angle and a low contrast ratio.

In order to achieve a better result of the in-plane electric field, a comb-shaped electrode array is built in the IPS-LCD to solve the problems such as an insufficient aperture ratio and crosstalk produced between data lines and common electrodes. FIGS. 1A and 1B are sectional diagrams of a conventional IPS-LCD, and FIG. 1C is a top view showing an electrode array within a pixel area of an IPS-LCD according to the prior art. FIG. 1A shows the alignment of the liquid crystal molecules at an off state, and FIG. 1B shows the alignment of the liquid crystal molecules at an on state. The IPS-LCD has a lower glass substrate 10, an upper glass substrate 12, and a liquid crystal layer 14 disposed in a space between the two parallel glass substrates 10 and 12. On the lower glass substrate 10, serving as a TFT substrate, a plurality of strip-shaped common electrodes 16 arranged as a comb-shape structure is patterned on the lower glass substrate 10, an insulating layer 18 is deposited on the common electrodes 16 and the lower glass substrate 10, and a plurality of strip-shaped pixel electrodes 20 arranged as a comb-shape structure is patterned on the insulating layer 18.

As shown in FIG. 1A, before an external voltage is applied to the IPS-LCD, the liquid crystal molecules 14A are aligned in a direction parallel to the lower glass substrate 10. As shown in FIG. 1B, when an external voltage is applied to the IPS-LCD, an in-plane electric field is generated between the common electrode 16 and the pixel electrode 20, resulting in a rotation of the liquid crystal molecules 14B toward the in-plane electric field.

Depending on the material and the structure design of the common electrode 16 and the pixel electrode 20, the conventional comb-shaped electrode array is classified as three types. FIGS. 2A to 2C are sectional diagrams showing three types of the common electrode 16 and the pixel electrode 20 in the conventional comb-shaped electrode array. In the first type, as shown in FIG. 2A, the common electrode 16 and the pixel electrode 20 are patterned on the same plane and made of a transparent conductive material, such as ITO or IZO. In the second type, as shown in FIG. 2B, the common electrode 16 made of a non-transparent conductive material, such as Al and MoW, is patterned on the lower glass substrate 10

followed by depositing the insulating layer 18, and then the pixel electrode 20 made of a transparent conductive material, such as ITO or IZO, is patterned on the insulating layer 18. In the third type, as shown in FIG. 2C, the common electrode 16 and the pixel electrode 20 are patterned on the same plane and made of a non-transparent conductive material, such as Al and MoW. By comparison, the first type shown in FIG. 2A can provide a greater luminance to the IPS-LCD than the second type shown in FIG. 2B and the third type shown in FIG. 2C, but provides a worsen view-angle characteristic than the second type and the third type. Also, the third type severely decreases the luminance of the IPS-LCD because most of the light is blocked by the non-transparent conductive material. Therefore, the second type shown in FIG. 2B is the most common type used in the conventional comb-shaped electrode array.

However, as to the second type, since the common electrode 16 and the pixel electrode 20 are patterned on different planes, it is possible to form different intervals between the common electrodes 16 and the pixel electrodes 20 on the electrode array caused by misalignment in the photolithography process. FIG. 3A is a sectional diagram showing an ideal case when a constant interval is formed between the common electrode 16 and the pixel electrode 20. FIG. 3B is a transmittance-position diagram according to the electrode array shown in FIG. 3A. FIG. 4A is a sectional diagram showing a practical case when different intervals are formed between the common electrodes 16 and the pixel electrodes 20. FIG. 4B is a transmittance-position diagram according to the electrode array shown in FIG. 4A. As shown in FIGS. 3A and 3B, the interval between the common electrode 16 and the pixel electrode 20 is a constant S1, and each S1 spacing region has the same degree of in-plane electric field, resulting in the same capacitance and transmittance. In contrast, as shown in FIGS. 4A and 4B, the intervals between the common electrode 16 and the pixel electrode 20 are different, such as S1 and S2, and the S1 spacing region and the S2 spacing region have different degrees of in-plane electric field, resulting in different capacitances and transmittances. In this practical case, demerits such as trip mura, shot mura and flicker are commonly found in the conventional IPS-LCD.

SUMMARY OF THE INVENTION

An object of the present invention is to provide an IPS-LCD with a compensation electrode structure to form an alignment free electrode array to solve the demerits found in the prior art.

An IPS-LCD with a compensation electrode structure comprises a first glass substrate and a second glass substrate arranging in parallel to each other, and liquid crystal layer formed in a space between first glass substrate and the second glass substrate. A plurality of gate lines extending in a first direction is formed on the first glass substrate, and a plurality of data lines extending in a second direction are formed on the first glass substrate, wherein the second direction is perpendicular to the first direction. Thus, the data lines and gate lines constitute an array of pixel areas arranging in a matrix form. A TFT is formed in each pixel area.

A comb-shaped common electrode structure, a comb-shaped pixel electrode structure and a compensation electrode structure are disposed in each pixel area on the first glass substrate. The comb-shaped common electrode structure comprises a common line parallel to the gate line and at least two common electrodes extending in the second direc-

tion. The comb-shaped pixel electrode structure comprises a bar near the gate line and at least one pixel electrode which extends in the second direction and is inter-digitated with the two common electrodes. The compensation electrode structure comprises at least a first compensation electrode and a second compensation electrode that extend in the second direction and are patterned on the same plane with the pixel electrode. The two compensation electrodes overlap the two common electrodes respectively, and a first interval between the first compensation electrode and the pixel electrode is equal to a second interval between the pixel electrode and the second compensation electrode.

It is an advantage of the present invention that the same degree of in-plane electric field is formed within the first interval and the second interval to provide the same capacitance and transmittance. This eliminates trip mura, shot mura and flicker found in the conventional IPS-LCD.

This and other objective of the present invention will no doubt become obvious to those of ordinary skill in the art after having read the following detailed description of the preferred embodiments which are illustrated in the various figures and drawings.

BRIEF DESCRIPTION OF THE DRAWINGS

The present invention can be more fully understood by reading the subsequent detailed description in conjunction with the examples and references made to the accompanying drawings, wherein:

FIG. 1A is a sectional diagram showing the alignment of the liquid crystal molecules at an off state according to the conventional IPS-LCD.

FIG. 1B is a sectional diagram showing the alignment of the liquid crystal molecules at an on state according to the conventional IPS-LCD.

FIG. 1C is a top view showing an electrode array within a pixel area of an IPS-LCD according to the prior art.

FIG. 2A is a sectional diagram showing the first type of the common electrode and the pixel electrode in the conventional comb-shaped electrode array.

FIG. 2B is a sectional diagram showing the second type of the common electrode and the pixel electrode in the conventional comb-shaped electrode array.

FIG. 2C is a sectional diagram showing the third type of the common electrode and the pixel electrode in the conventional comb-shaped electrode array.

FIG. 3A is a sectional diagram showing an ideal case when a constant interval is formed between the common electrode and the pixel electrode.

FIG. 3B is a transmittance-position diagram according to the electrode array shown in FIG. 3A.

FIG. 4A is a sectional diagram showing a practical case when different intervals are formed between the common electrodes and the pixel electrodes.

FIG. 4B is a transmittance-position diagram according to the electrode array shown in FIG. 4A.

FIG. 5A is a top view showing an electrode array within a pixel area of an IPS-LCD according to the first embodiment of the present invention.

FIG. 5B is a sectional diagram along line I-I' shown in FIG. 5A.

FIG. 5C is a sectional diagram showing an IPS-LCD according to the invention.

FIG. 6 is a transmittance-position diagram according to one preferred case according to the first embodiment of the present invention.

FIGS. 7A to 7C are sectional diagrams showing three preferred cases of the overlapping relation between the common electrode and the compensation electrode.

FIG. 8A is a top view showing an electrode array within a pixel area of an IPS-LCD according to the second embodiment of the present invention.

FIG. 8B is a sectional diagram along line I-I' shown in FIG. 8A.

FIG. 9A is a top view showing an electrode array within a pixel area of an IPS-LCD according to the third embodiment of the present invention.

FIG. 9B is a sectional diagram along line I-I', shown in FIG. 9A.

DETAILED DESCRIPTION OF THE PREFERRED EMBODIMENT

[First Embodiment]

FIG. 5A is a top view showing an electrode array within a pixel area of an IPS-LCD according to the first embodiment of the present invention. FIG. 5B is a sectional diagram along line I-I' shown in FIG. 5A. FIG. 5C is a sectional diagram showing an IPS-LCD according to the invention.

As shown in FIG. 5C, an IPS-LCD comprises a pair of glass substrates **30** and **50** arranging in parallel and a liquid crystal layer **52** formed in a space between the two substrates **30** and **50**.

As shown in FIGS. 5A and 5B, on the bottom substrate **30** (called a TFT substrate), a plurality of gate lines **32** extending along X-axis and a plurality of data lines **34** extending along Y-axis forms pixel areas **36** arranged in a matrix form. Each of the pixel areas **36** comprises a TFT **38**, a comb-shaped common electrode structure **40**, a comb-shaped pixel electrode structure **42**, and a compensation electrode structure **44**. In this case, the TFT **38** is formed near the intersection of the gate line **32** and the data line **34**. The comb-shaped common electrode structure **40** comprises a common line **40a** disposed in X-axis and a plurality of comb-teeth extending away from the common line **40a** along a first direction of Y-axis. Preferably, as shown in FIG. 5A, there are three comb-teeth **40b₁**, **40b₂**, **40b₃** extending away from the common line **40a** along a first direction of Y-axis. The comb-shape pixel electrode structure **42** comprises a bar **42a** disposed near the TFT **38** and at least one comb-tooth extending away from the bar **42a** along a second direction of Y-axis. Preferably, as shown in FIG. 5B, there are two comb-teeth **42b₁**, **42b₂** extending away from the bar **42a** along a second direction of Y-axis. The two pixel electrodes **42b₁**, **42b₂** are inter-digitated with the three common electrodes **40b₁**, **40b₂**, **40b₃**, and therefore the pixel area **36** is divided into four spacing regions. In corresponding to the three comb-teeth **40b₁**, **40b₂**, **40b₃** of the common electrode structure **40**, the compensation electrode structure **44** has three compensation electrodes **44a₁**, **44a₂**, **44a₃** that extend along Y-axis and are patterned on the same plane with the pixel electrodes **42b**. Also, the three compensation electrodes **44a₁**, **44a₂**, **44a₃** overlap the three common electrodes **40b₁**, **40b₂**, **40b₃**, respectively.

As shown in FIG. 5B, the width W1 of the common electrode **40b** is less than the width W3 of the compensation electrodes **44a**. Preferably, the width W1 and the width W3 satisfy the formula: $W3 - W1 \geq 1 \mu\text{m}$. Moreover, the first interval between the compensation electrode **44a₁** and the pixel electrode **42b₁**, the second interval between the pixel electrode **42b₁** and the compensation electrode **44a₂**, the third interval between the compensation electrode **44a₂** and

the pixel electrode $42b_2$, and the fourth interval between the pixel electrode $42b_2$ and the compensation electrode $44a_3$, are fixed at a constant distance D. Furthermore, each of the compensation electrodes $44a_1$, $44a_2$, $44a_3$ is electrically connected to common line $40a$ via a through hole 46 . In addition, the profile of the compensation electrode structure 44 is a design choice. Preferably, the compensation electrode structure 44 is designed as a plurality strips or a comb shape.

The common electrodes $40b$ may use a non-transparent material, such as Al and MoW, and may be patterned on same plane with the common line $40a$, the data line 34 or the gate line 32 . The pixel electrode $42b$ and the compensation electrode $44a$ may use a transparent material, such as ITO or IZO, and patterned on an insulating layer 41 that is deposited on the common electrodes $40b$. Also, since the compensation electrodes $44a$ and the pixel electrodes $42b$ are patterned on the same plane by the same step of photolithography process, the interval between two adjacent compensation electrode $44a$ and pixel electrode $42b$ is easily fixed at a constant distance D. Therefore, no matter the distance S1 (between the common electrode $40b_1$ and the pixel electrode $42b_1$), the distance S2 (between the pixel electrode $42b_1$ and the common electrode $40b_2$), the distance S3 (between the common electrode $40b_2$ and the pixel electrode $42b_2$, and the distance S4 (between the pixel electrode $42b_2$ and the common electrode $40b_3$) are the same or not, each D spacing region (between the compensation electrode $44a$ and the pixel electrode 42) has the same degree of in-plane electric field, resulting in the same capacitance and transmittance. This eliminates trip mura, shot mura and flicker found in the conventional IPS-LCD.

The width W1, W2, W3 of the common electrode $40b$, the pixel electrode $42b$ and the compensation electrode $44a$ are not limited. Preferably, W1=2~3 μm , W2=4~5 μm , W3=4~5 μm , and D=9~15 μm . In one preferred case, W1=3 μm , W2=4 μm , W3=4 μm and D=9 μm provide a good result as shown in FIG. 6, in which each D spacing region has the same transmittance. The overlapping relation between the compensation electrode $44a$ and the common electrode $40b$ is not limited. In one preferred case, the middle of the common electrode $40b$ is aligned to the middle of the compensation electrode $44a$, as shown in FIG. 7A. In another preferred case, the left sidewall of the common electrode $40b$ is aligned to the left sidewall of the compensation electrode $44a$, as shown in FIG. 7B. In the other preferred case, the right sidewall of the common electrode $40b$ is aligned to the right sidewall of the compensation electrode $44a$, as shown in FIG. 7C.

[Second Embodiment]

FIG. 8A is a top view showing an electrode array within a pixel area of an IPS-LCD according to the second embodiment of the present invention. FIG. 8B is a sectional diagram along line I-I' shown in FIG. 8A.

On the glass substrate 30 , the electrode array within the pixel area 36 is almost the same as that described in the first embodiment. The only one difference is that the common electrodes $40b$ are not connected to the common line $40a$, and thus the common electrode $40b$ becomes a floating layer under the compensation electrode $44a$. The common electrodes $40b$ may use a non-transparent material, such as Al and MoW, and may be patterned on same plane with the common line $40a$, the data line 34 or the gate line 32 . It is noticed that the compensation electrode $44a$ is still electrically connected to the common line $40a$ via the through hole 46 .

As shown in FIG. 8B, the interval between two adjacent compensation electrode $44a$ and pixel electrode $42b$ is easily fixed at a constant distance D. Therefore, no matter the distance S1, the distance S2, the distance S3, and the distance S4 are the same or not, each D spacing region has the same degree of in-plane electric field, resulting in the same capacitance and transmittance. This eliminates trip mura, shot mura and flicker found in the conventional IPS-LCD.

[Third Embodiment]

FIG. 9A is a top view showing an electrode array within a pixel area of an IPS-LCD according to the third embodiment of the present invention. FIG. 9B is a sectional diagram along line I-I' shown in FIG. 9A.

On the glass substrate 30 , the electrode array within the pixel area 36 is almost the same as that described in the second embodiment. The only one difference is that the common electrodes $40b$ uses a non-transparent material, such as Al and MoW, and is patterned on same plane with the data line 34 .

As shown in FIG. 9B, the interval between two adjacent compensation electrode $44a$ and pixel electrode $42b$ is easily fixed at a constant distance D. Therefore, no matter the distance S1, the distance S2, the distance S3, and the distance S4 are the same or not, each D spacing region has the same degree of in-plane electric field, resulting in the same capacitance and transmittance. This eliminates trip mura, shot mura and flicker found in the conventional IPS-LCD.

Those skilled in the art will readily observe that numerous modifications and alterations of the device may be made while retaining the teaching of the invention. Accordingly, the above disclosure should be construed as limited only by the metes and bounds of the appended claims.

What is claimed is:

1. An IPS-LCD with a compensation electrode structure, comprising:
 - a first glass substrate and a second glass substrate arranging in parallel to each other;
 - a liquid crystal layer formed in a space between first glass substrate and the second glass substrate;
 - a plurality of gate lines extending in a first direction and formed on the first glass substrate;
 - a plurality of data lines extending in a second direction and formed on the first glass substrate, wherein the second direction is perpendicular to the first direction, and the data lines and gate lines constitute a plurality of pixel areas arranging in a matrix form;
 - a plurality of TFT formed in the plurality of pixel areas respectively;
 - a plurality of comb-shaped common electrode structures disposed in the plurality of pixel areas respectively on the first glass substrate, wherein each comb-shaped common electrode structure comprises a common line parallel to the gate line and at least two common electrodes extending in the second direction;
 - a plurality of comb-shaped pixel electrode structures disposed in the plurality of pixel areas respectively on the first glass substrate, wherein each comb-shaped pixel electrode structure comprises a bar near the gate line and at least one pixel electrode which extends in the second direction and is inter-digitated with the two common electrodes; and
 - a plurality of compensation electrode structures disposed in the plurality of pixel areas respectively on the first

glass substrate, wherein each compensation electrode structure comprises at least a first compensation electrode and a second compensation electrode which extend in the second direction and are patterned on the same plane with the pixel electrode;

wherein, the first and second compensation electrodes overlap the two common electrodes respectively, and a first interval between the first compensation electrode and the pixel electrode is equal to a second interval between the pixel electrode and the second compensation electrode.

2. The IPS-LCD with a compensation electrode structure as claimed in claim 1, further comprising at least two through holes over the common line, in which the first and second compensation electrodes are electrically connected to the common line via the two through holes, respectively.

3. The IPS-LCD with a compensation electrode structure as claimed in claim 1, further comprising an insulating layer disposed between the compensation electrode and the common electrode.

4. The IPS-LCD with a compensation electrode structure as claimed in claim 1, wherein the pixel electrode and the compensation electrodes are made of a transparent conductive material.

5. The IPS-LCD with a compensation electrode structure as claimed in claim 1, wherein the pixel electrode and the compensation electrodes are ITO or IZO.

6. The IPS-LCD with a compensation electrode structure as claimed in claim 1, wherein the common electrodes are made of a non-transparent conductive material.

7. The IPS-LCD with a compensation electrode structure as claimed in claim 1, wherein the common electrodes are made of Al or MoW.

8. The IPS-LCD with a compensation electrode structure as claimed in claim 1, wherein each common electrode is made of the same material and patterned on the same plane with the common line.

9. The IPS-LCD with a compensation electrode structure as claimed in claim 1, wherein each common electrode is made of the same material and patterned on the same plane with the gate line.

10. The IPS-LCD with a compensation electrode structure as claimed in claim 1, wherein each common electrode is made of the same material and patterned on the same plane with the data line.

11. The IPS-LCD with a compensation electrode structure as claimed in claim 1, wherein each common electrode is electrically connected to the common line.

12. The IPS-LCD with a compensation electrode structure as claimed in claim 1, wherein each common electrode is not electrically connected to the common line.

13. The IPS-LCD with a compensation electrode structure as claimed in claim 1, wherein the width $W1$ of each common electrode and the width of each compensation electrode $W3$ satisfy the formula: $W3 - W1 \geq 1 \mu\text{m}$.

14. A method of forming an IPS-LCD with a compensation electrode structure, comprising steps of:

providing a glass substrate;

forming a plurality of gate lines extending in a first direction on the glass substrate;

forming a comb-shaped common electrode structure within each predetermined pixel area, wherein the comb-shaped common electrode structure comprises a common line parallel to the gate line and at least two common electrodes extending in a second direction that is perpendicular to the first direction;

forming an insulating layer to cover the gate lines, the comb-shaped common electrode structure and glass substrate;

forming a plurality of data lines extending in the second direction on the insulating layer, wherein the data lines and the gate lines constitute a plurality of pixel areas arranging in a matrix form;

forming a comb-shaped pixel electrode structure disposed in each pixel area on the insulating layer, wherein the comb-shaped pixel electrode structure comprises a bar near the gate line and at least one pixel electrode which extends in the second direction and is inter-digitated with the two common electrodes; and

forming a compensation electrode structure disposed in each pixel area, wherein the compensation electrode structure comprises at least a first compensation electrode and a second compensation electrode which extend in the second direction and are patterned on the same plane with the pixel electrode;

wherein, the first and second compensation electrodes overlap the two common electrodes respectively, and a first interval between the first compensation electrode and pixel electrode is equal to a second interval between the pixel electrode and the second compensation electrode.

15. The method of forming an IPS-LCD with a compensation electrode structure as claimed in claim 14, further comprising a step of forming a TFT within each pixel area.

16. The method of forming an IPS-LCD with a compensation electrode structure as claimed in claim 14, further comprising steps of:

forming at least two through holes over the common line; and

electrically connecting the first and second compensation electrodes and the common line via the two through holes, respectively.

17. The method of forming an IPS-LCD with a compensation electrode structure as claimed in claim 14, wherein the pixel electrode and the compensation electrodes are made of a transparent conductive material.

18. The method of forming an IPS-LCD with a compensation electrode structure as claimed in claim 14, wherein the common electrodes are made of a non-transparent conductive material.

19. The method of forming an IPS-LCD with a compensation electrode structure as claimed in claim 14, wherein each common electrode is made of the same material and patterned on the same plane with the common line, the gate line or the data line.

20. The method of forming an IPS-LCD with a compensation electrode structure as claimed in claim 14, wherein each common electrode is electrically connected to the common line.

21. The method of forming an IPS-LCD with a compensation electrode structure as claimed in claim 14, wherein each common electrode is not electrically connected to the common line.

22. The method of forming an IPS-LCD with a compensation electrode structure as claimed in claim 14, wherein the width $W1$ of each common electrode and the width of each compensation electrode $W3$ satisfy the formula: $W3 - W1 \geq 1 \mu\text{m}$.

专利名称(译)	具有补偿电极结构的面内切换液晶显示器及其形成方法		
公开(公告)号	US6765642	公开(公告)日	2004-07-20
申请号	US10/245336	申请日	2002-09-18
[标]申请(专利权)人(译)	LEE DEUK SU		
申请(专利权)人(译)	LEE DEUK SU		
当前申请(专利权)人(译)	瀚宇彩晶股份有限公司.		
[标]发明人	LEE DEUK SU		
发明人	LEE, DEUK SU		
IPC分类号	G02F1/13 G02F1/1343 G02F1/1333		
CPC分类号	G02F1/134363 G02F1/133707		
审查员(译)	KIM, 罗伯特H.		
其他公开文献	US20040051834A1		
外部链接	Espacenet USPTO		

摘要(译)

一种具有补偿电极结构的IPS-LCD。在每个像素区域中，在第一Y方向上延伸的至少两个公共电极和在第二Y方向上延伸的至少一个像素电极彼此交叉数字化。而且，在Y方向上延伸的至少两个补偿电极在与像素电极相同的平面上被图案化，并且分别与两个公共电极重叠。第一补偿电极和像素电极之间的第一间隔等于像素电极和第二补偿电极之间的第二间隔。

