



US 20080204636A1

(19) **United States**  
(12) **Patent Application Publication**  
**Ge et al.**

(10) **Pub. No.: US 2008/0204636 A1**  
(43) **Pub. Date: Aug. 28, 2008**

(54) **TRANSFLECTIVE LIQUID CRYSTAL DISPLAY**

**Publication Classification**

(75) Inventors: **Zhibing Ge**, Orlando, FL (US);  
**Xinyu Zhu**, Orlando, FL (US);  
**Thomas Xinzhang Wu**, Oviedo, FL (US);  
**Shin-Tson Wu**, Oviedo, FL (US);  
**Wang-Yang Li**, Tainan County (TW);  
**Chung-Kuang Wei**, Taipei City (TW)

(51) **Int. Cl.**  
**G02F 1/1335** (2006.01)  
(52) **U.S. Cl.** ..... **349/114**

(57) **ABSTRACT**

A display includes a plurality of pixel circuits, each pixel circuit including a first electrode, a second electrode, a reflective region, and a transmissive region. The reflective region reflects ambient light and includes a first portion of a liquid crystal layer and a polarization dependent reflector. The transmissive region transmits backlight and includes a second portion of the liquid crystal layer. A dielectric layer is between the first and second electrodes in one of the reflective region and the transmissive region, the dielectric layer configured such that when a pixel voltage is applied to the first and second electrodes, the percentage of the pixel voltage applied across the first portion of the liquid crystal layer is different from the percentage of the pixel voltage applied across the second portion of the liquid crystal layer. The display includes a backlight module to generate the backlight.

Correspondence Address:  
**FISH & RICHARDSON PC**  
**P.O. BOX 1022**  
**MINNEAPOLIS, MN 55440-1022**

(73) Assignees: **CHI MEI OPTOELECTRONICS CORPORATION**, Tainan (TW);  
**UNIVERSITY OF FLORIDA RESEARCH FOUNDATION, INC.**, Orlando, FL (US)

(21) Appl. No.: **11/678,691**

(22) Filed: **Feb. 26, 2007**

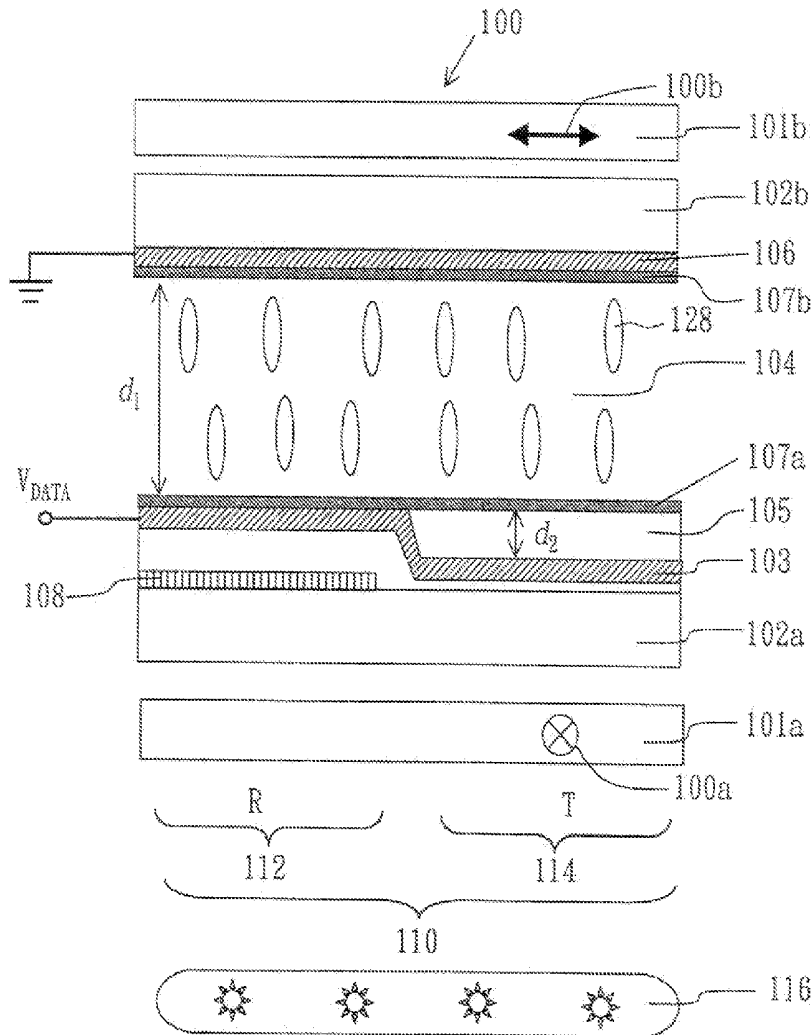

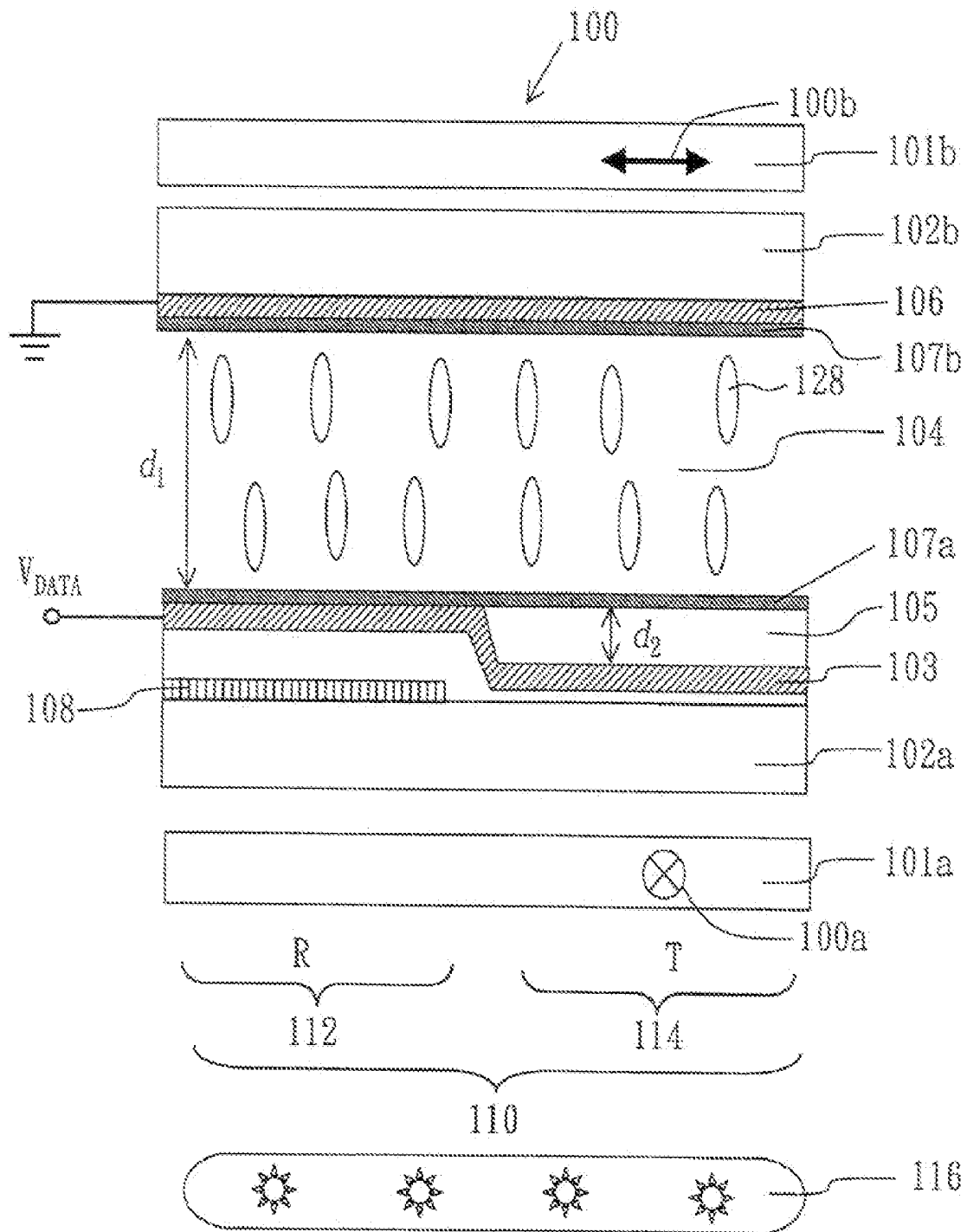

FIG. 1

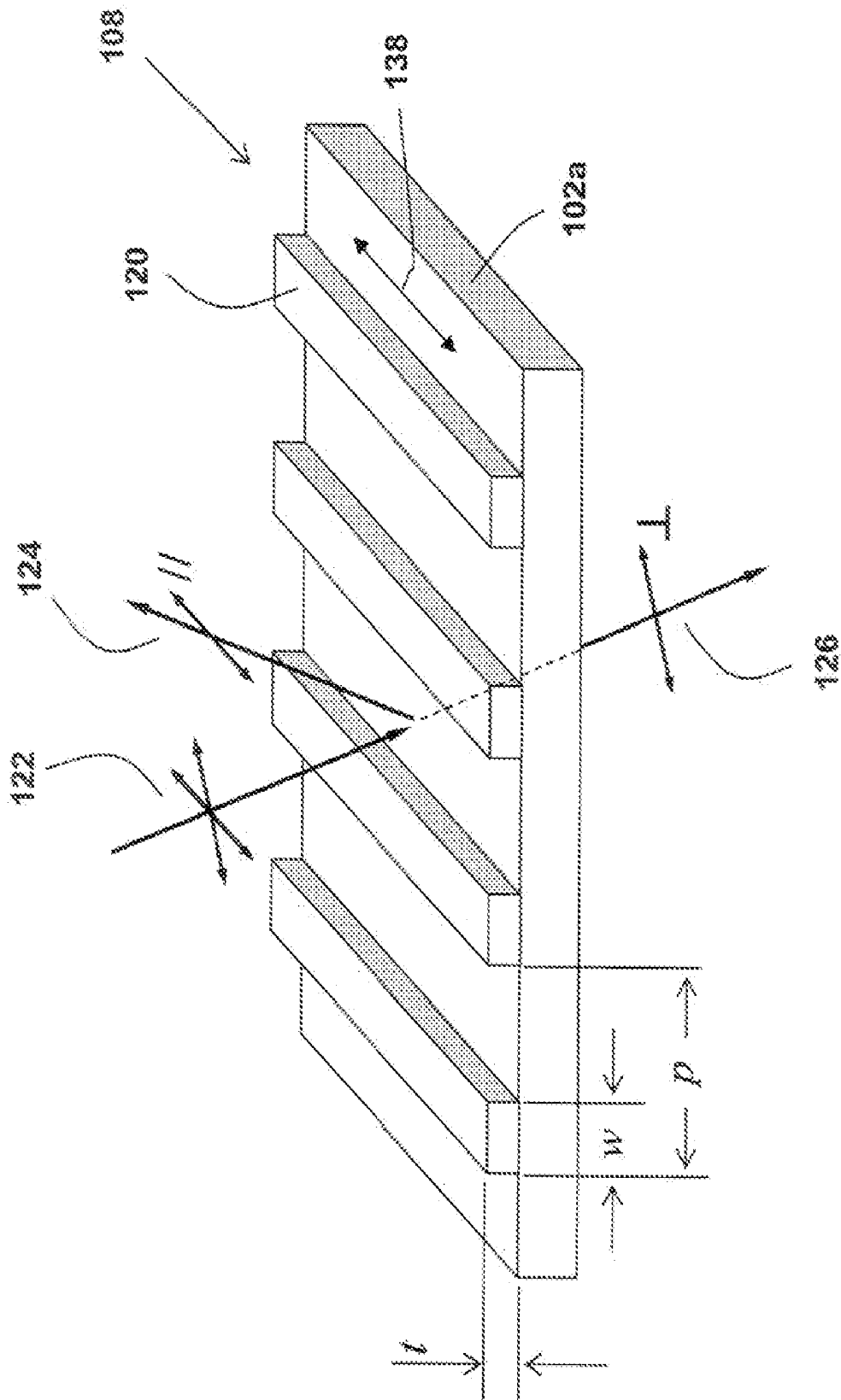

FIG. 2

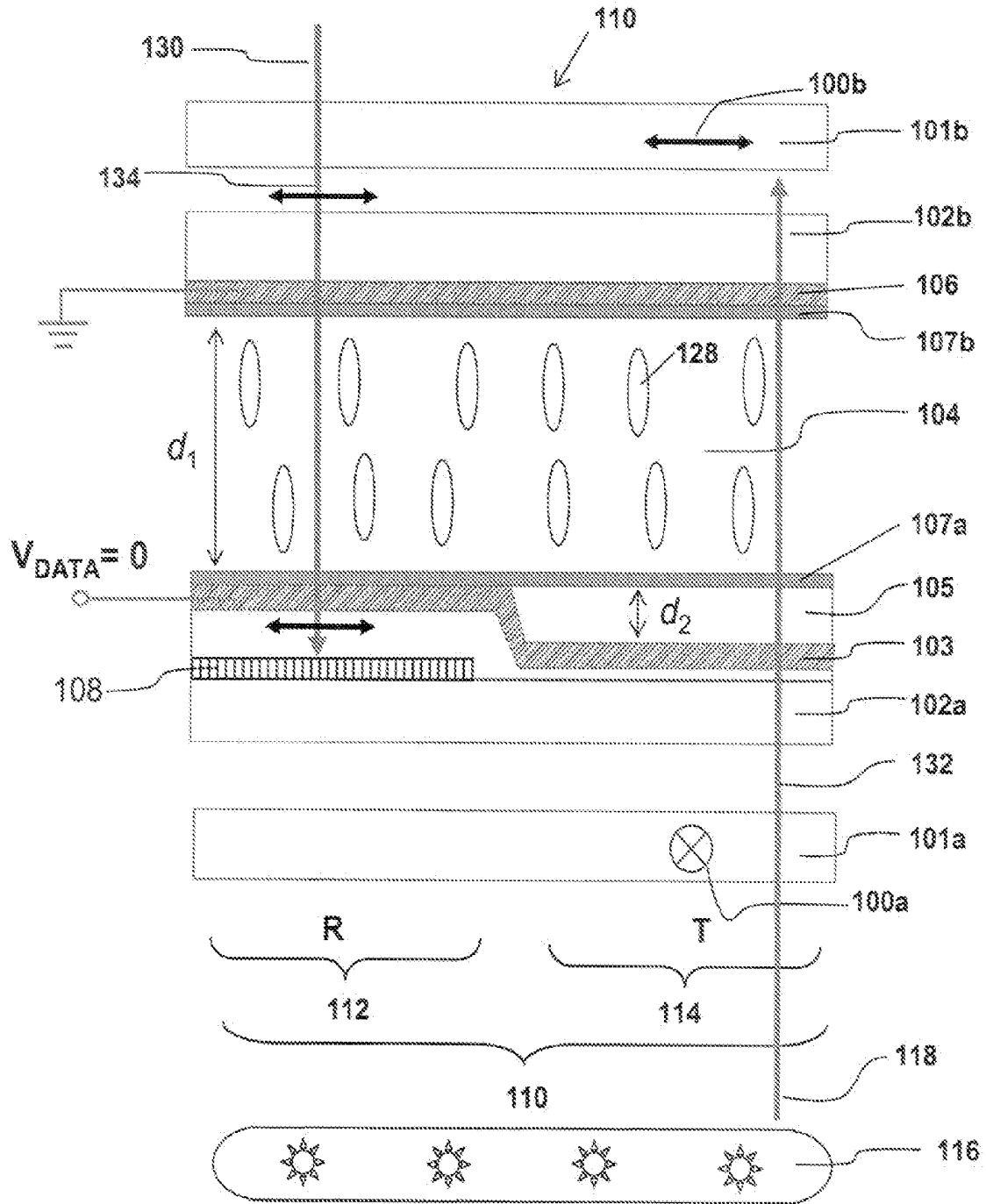

FIG. 3A

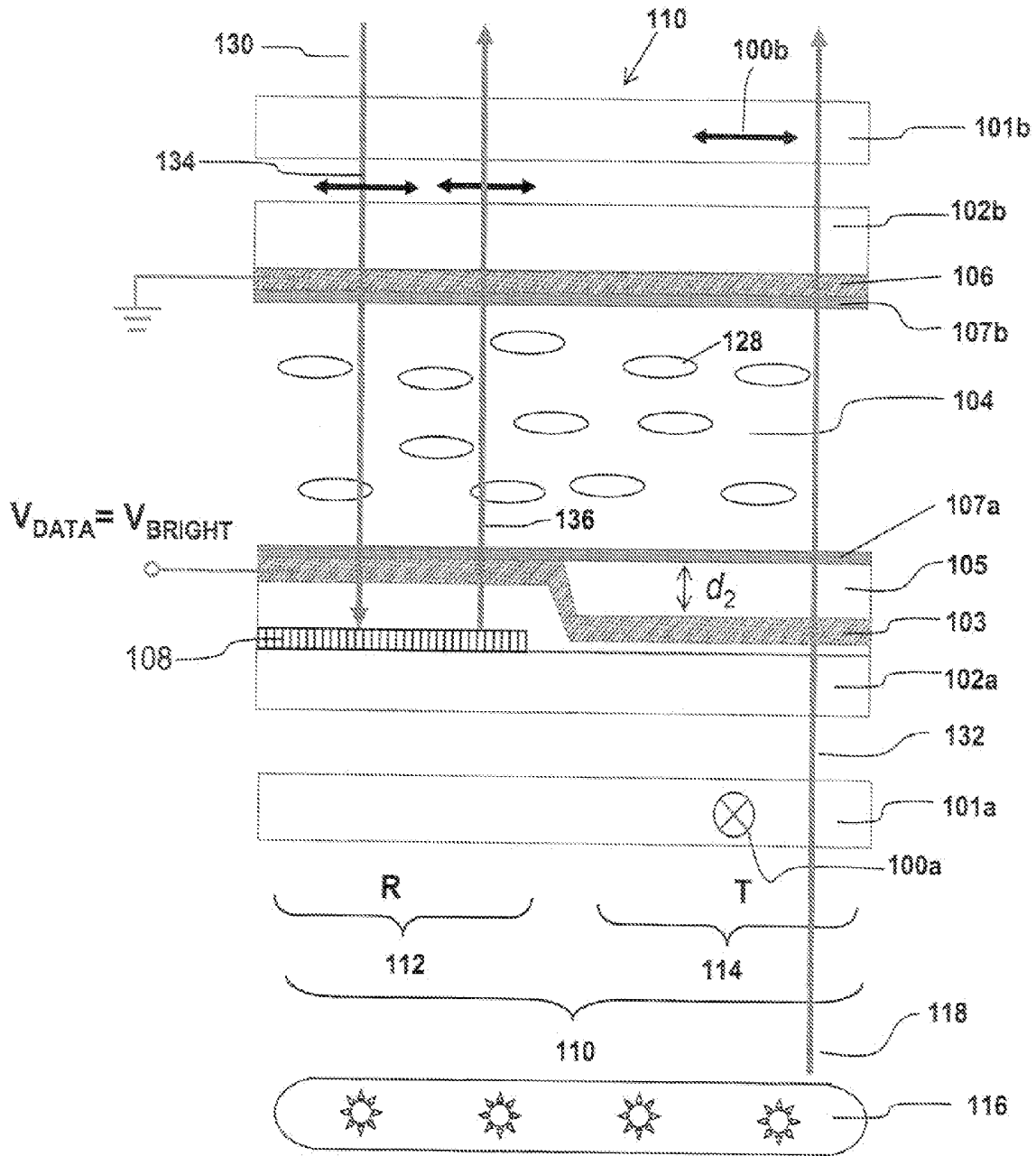

FIG. 3B

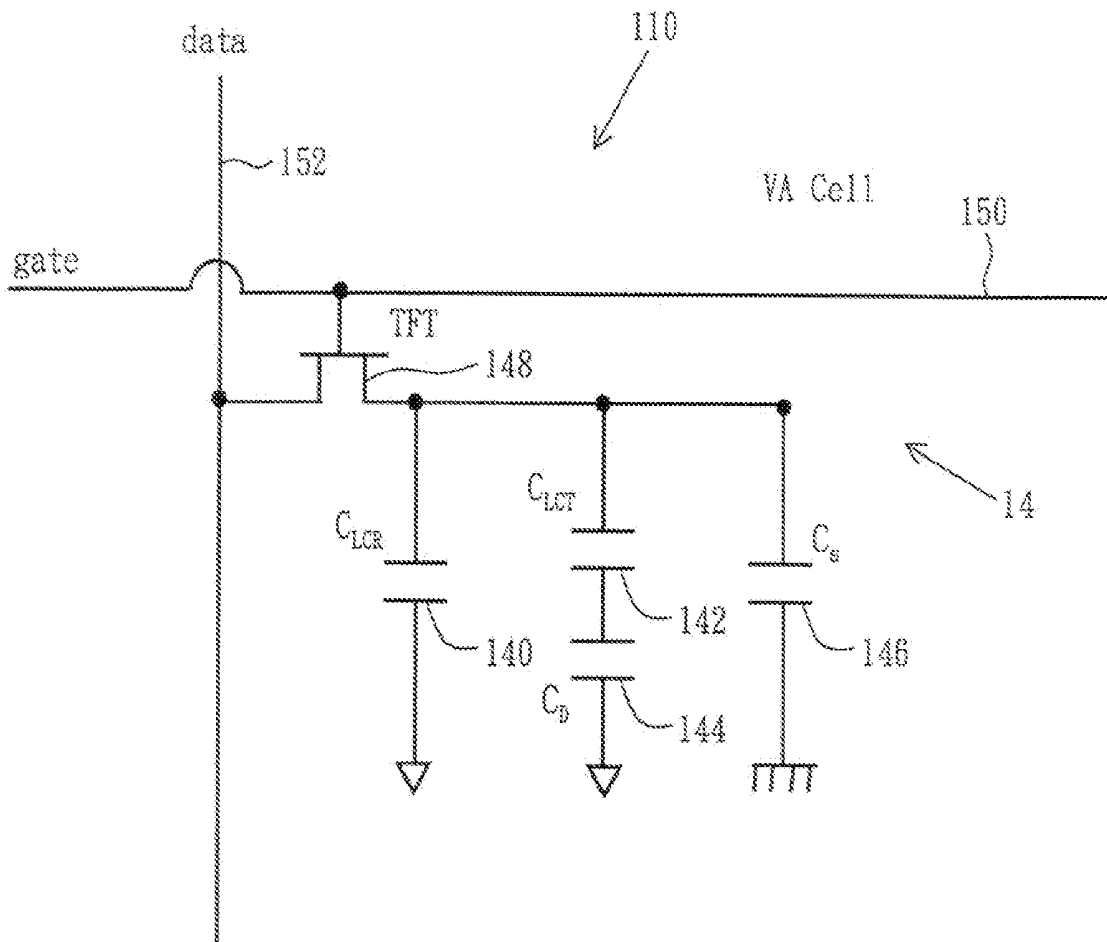

FIG. 4

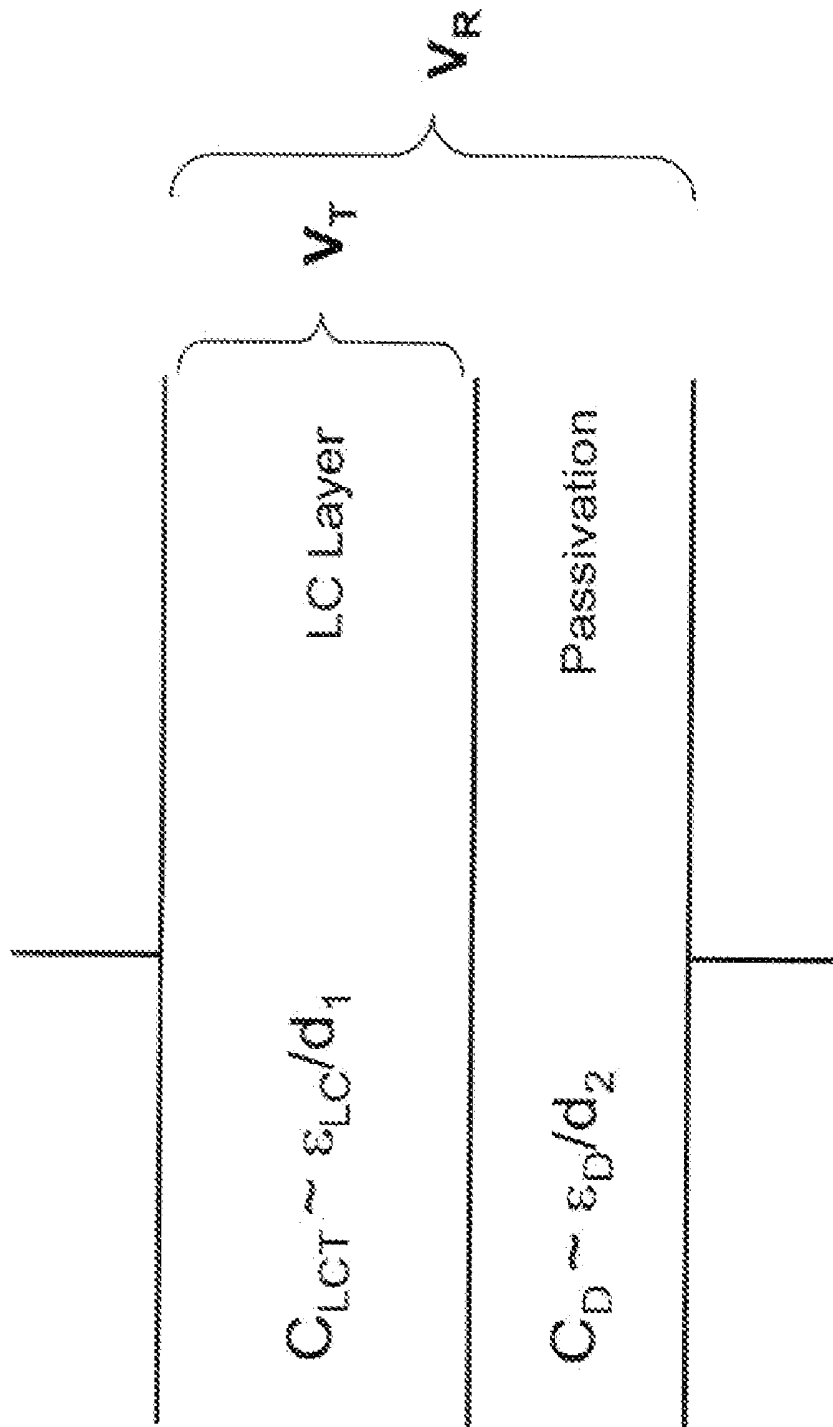

FIG. 5

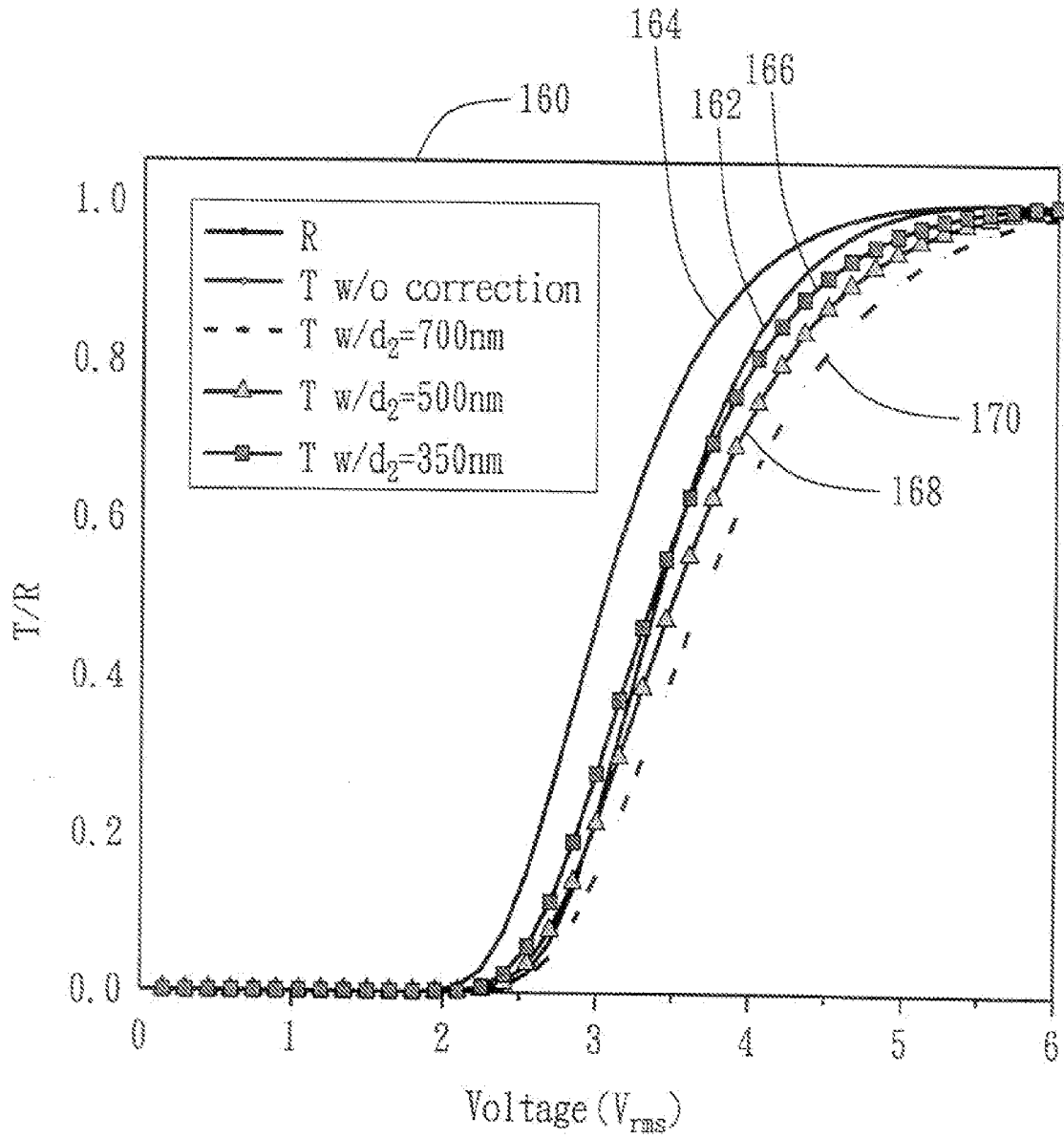

FIG. 6

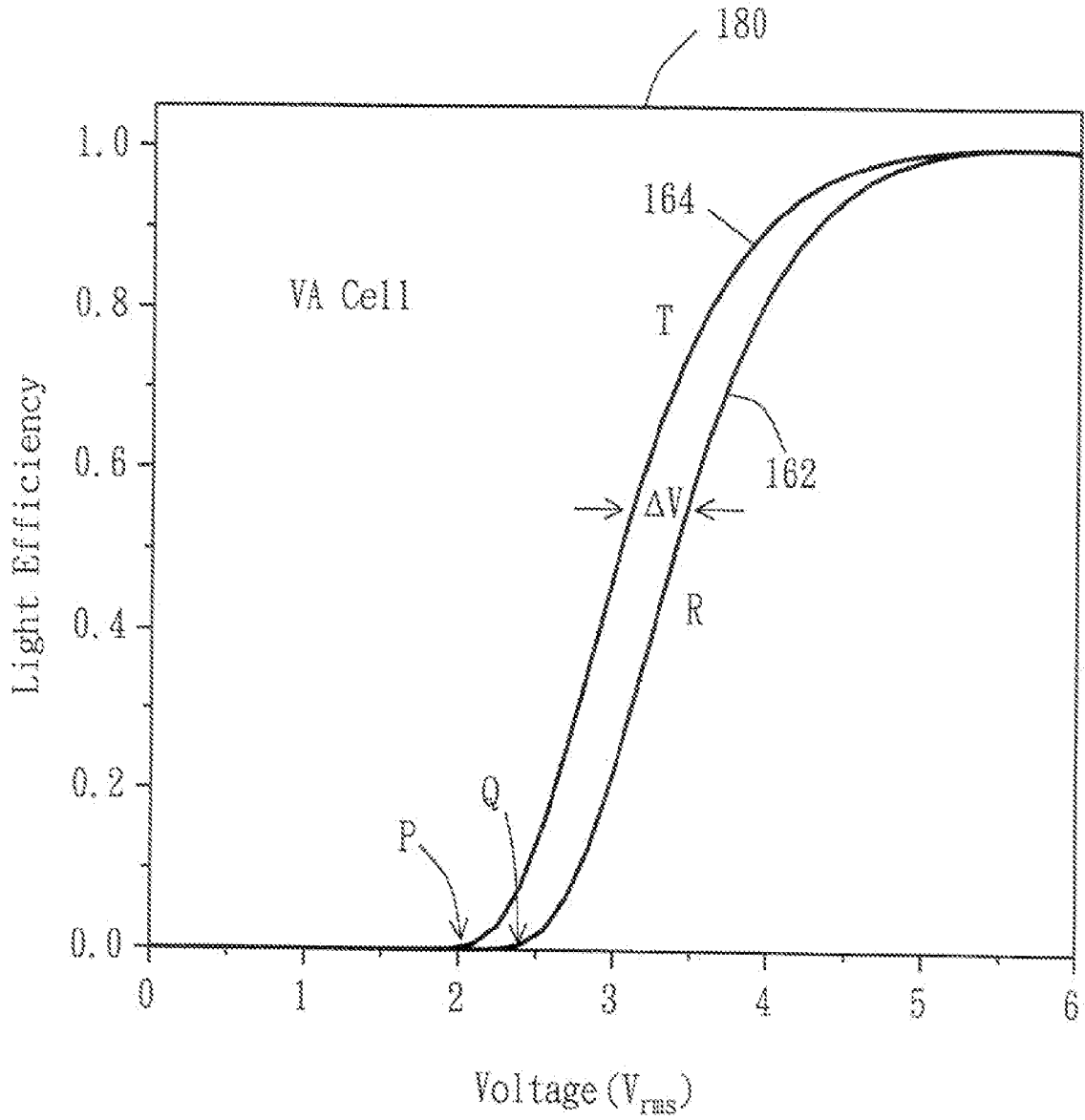

FIG. 7

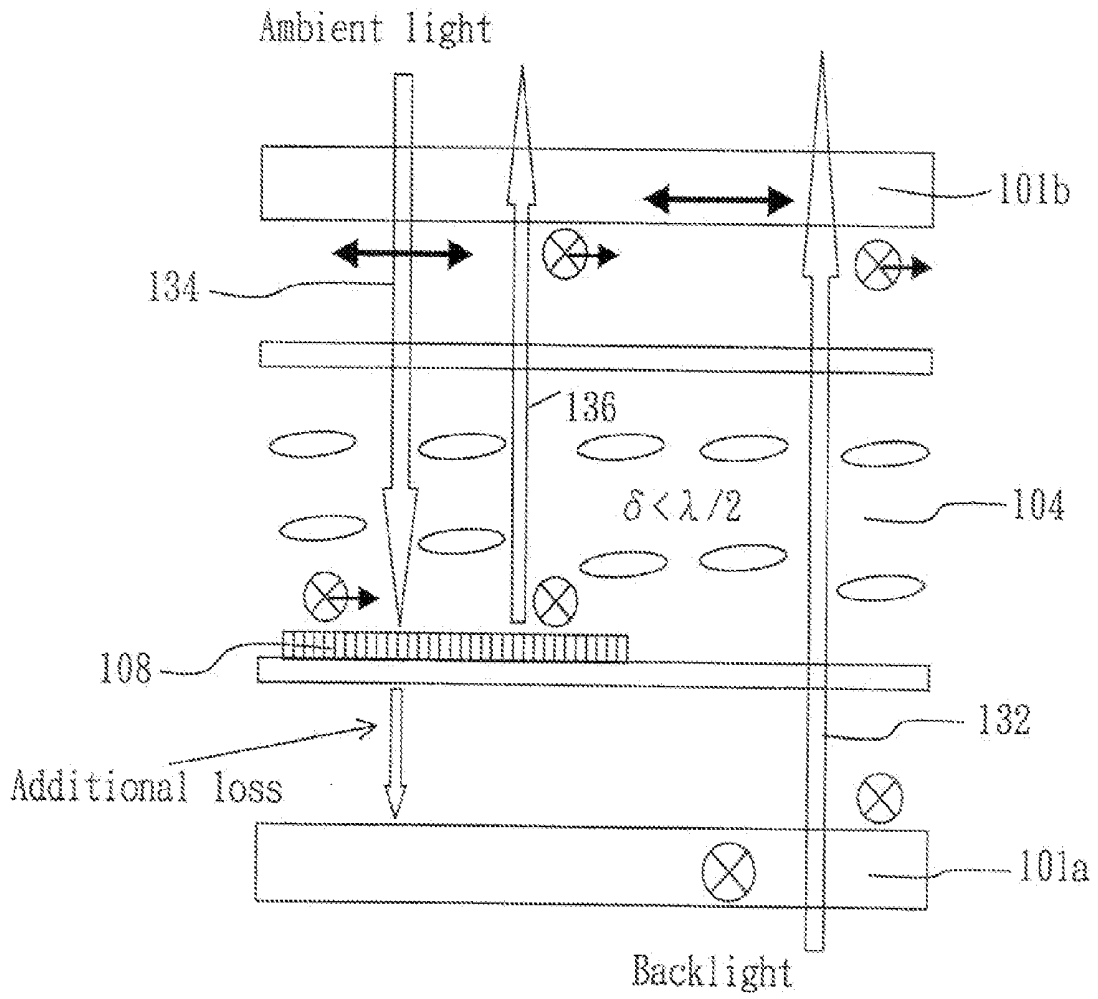

FIG. 8





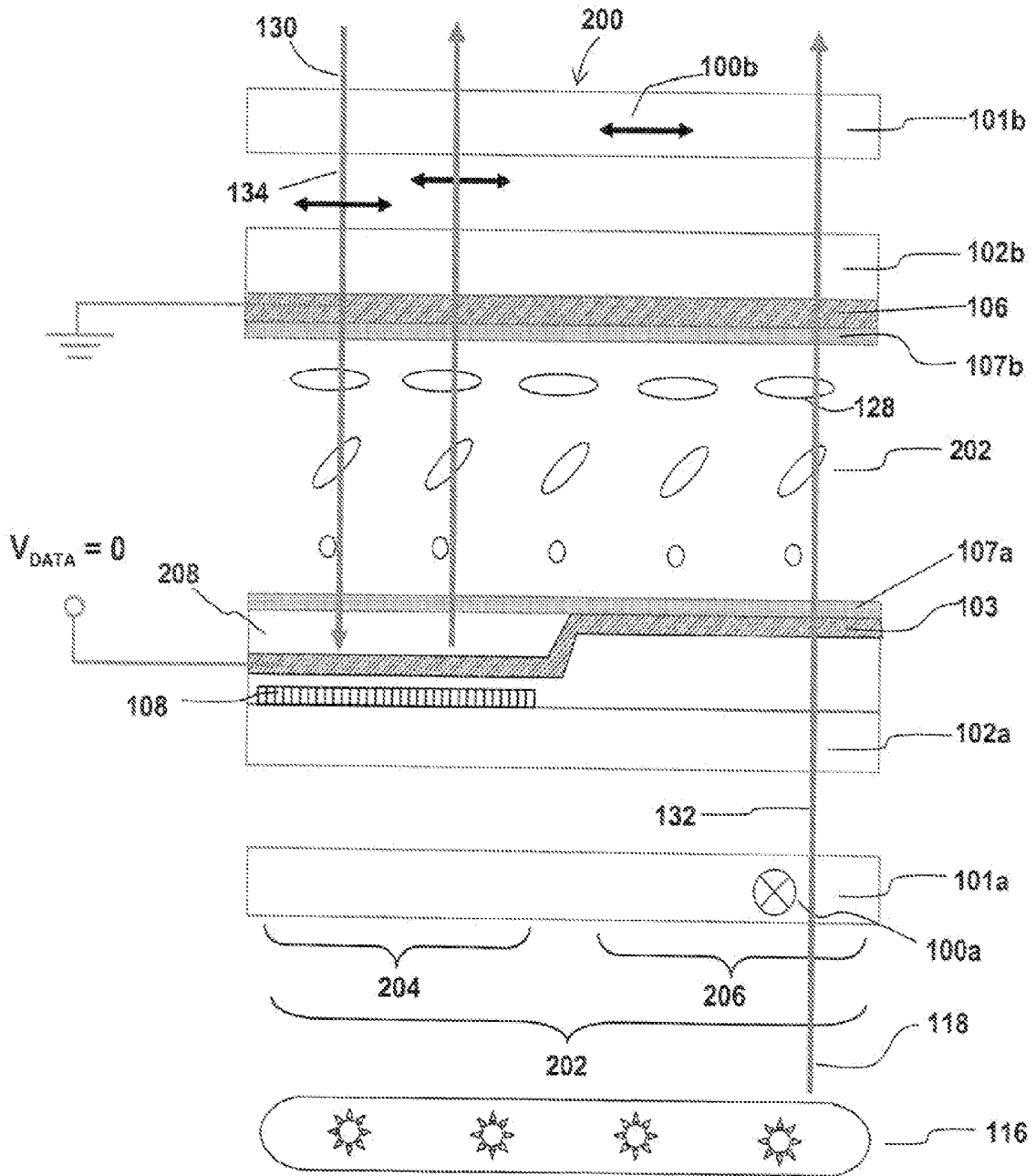

FIG. 11A

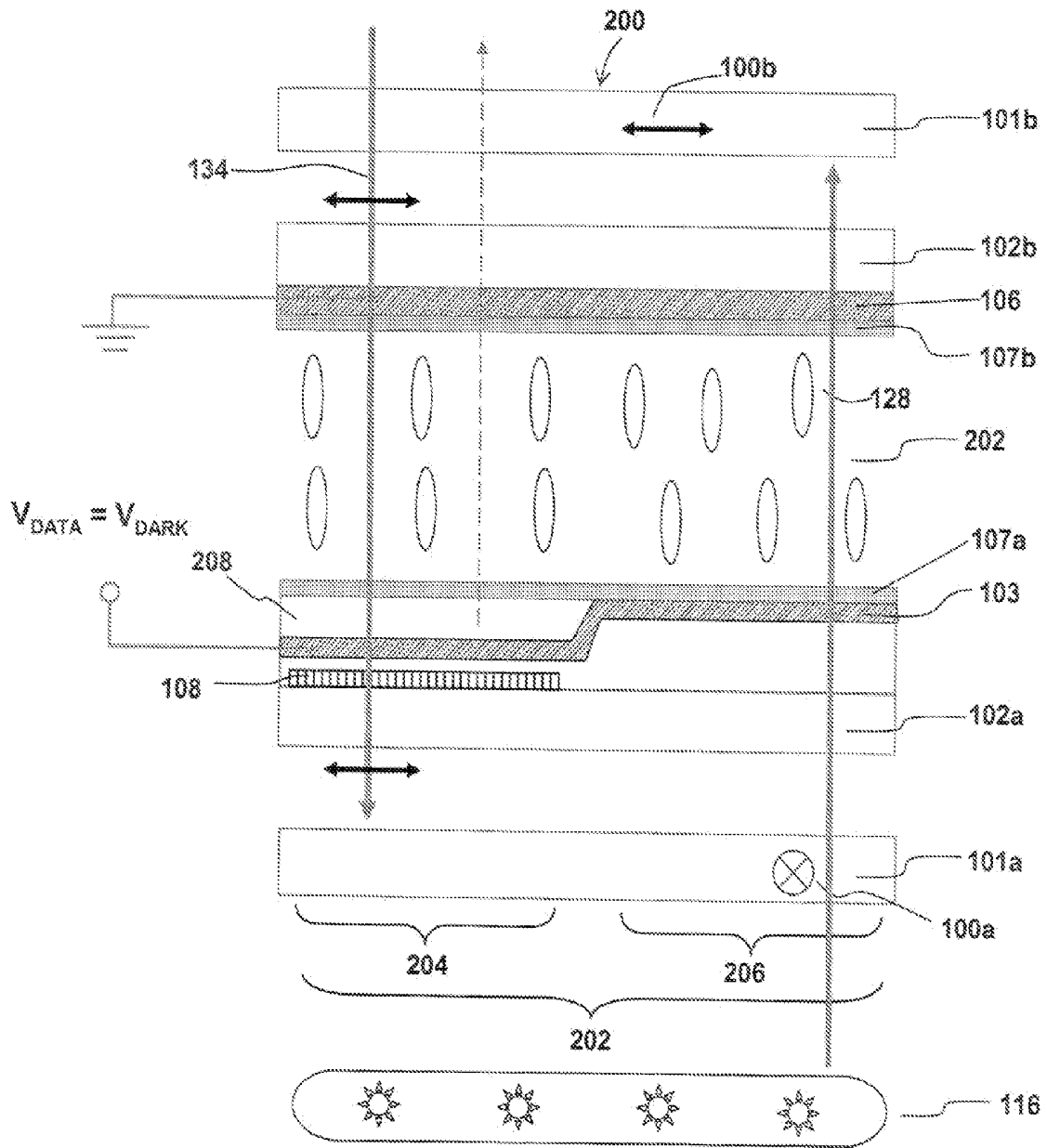

FIG. 11B

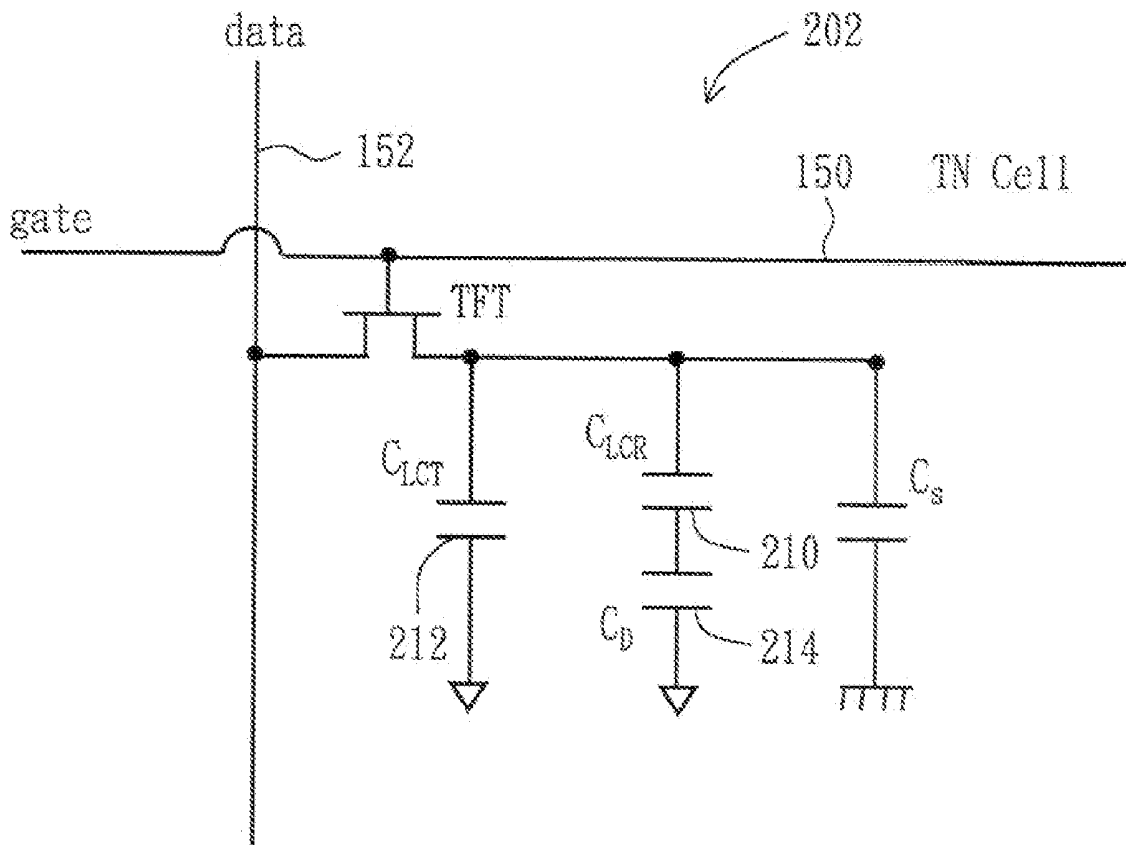

FIG. 12

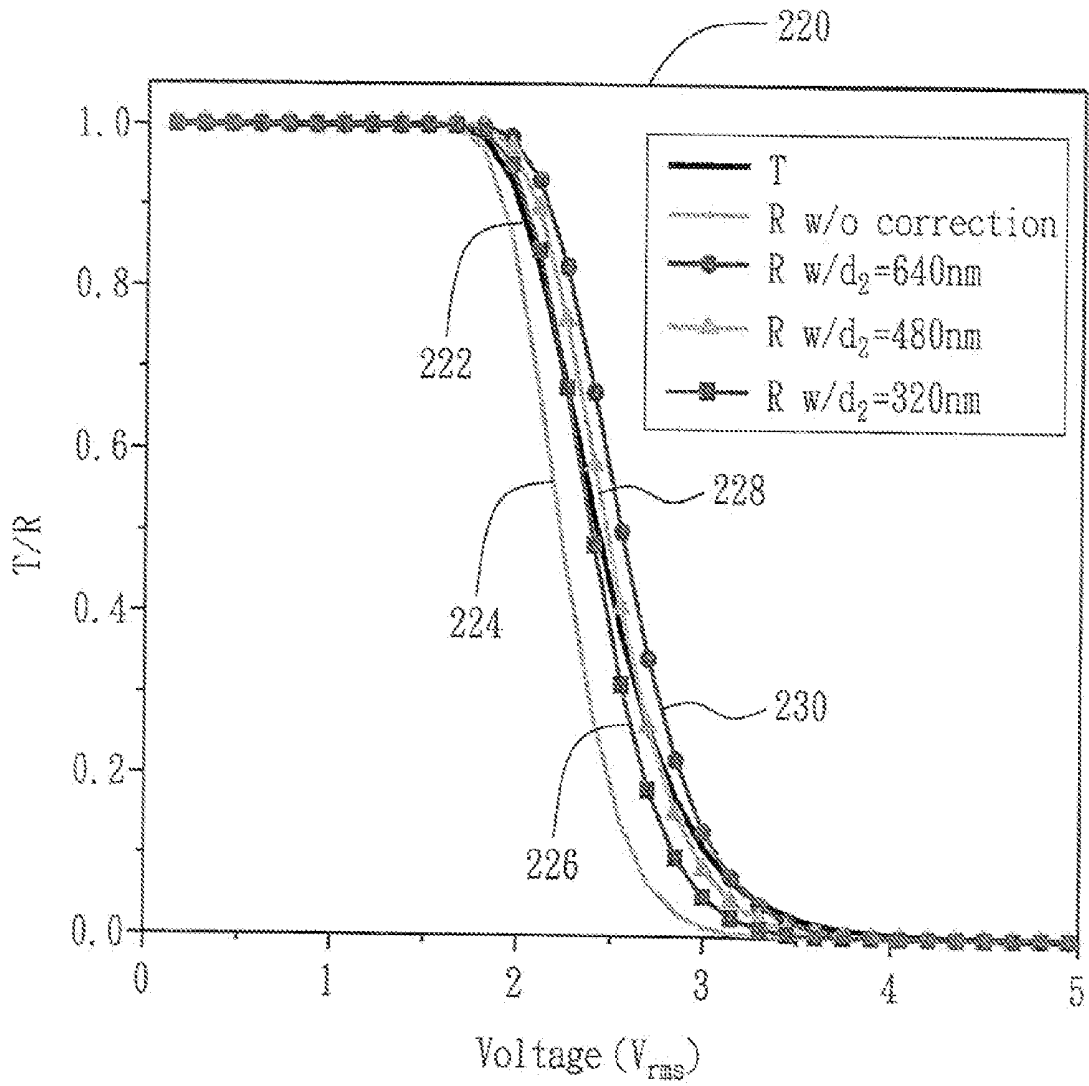

FIG. 13

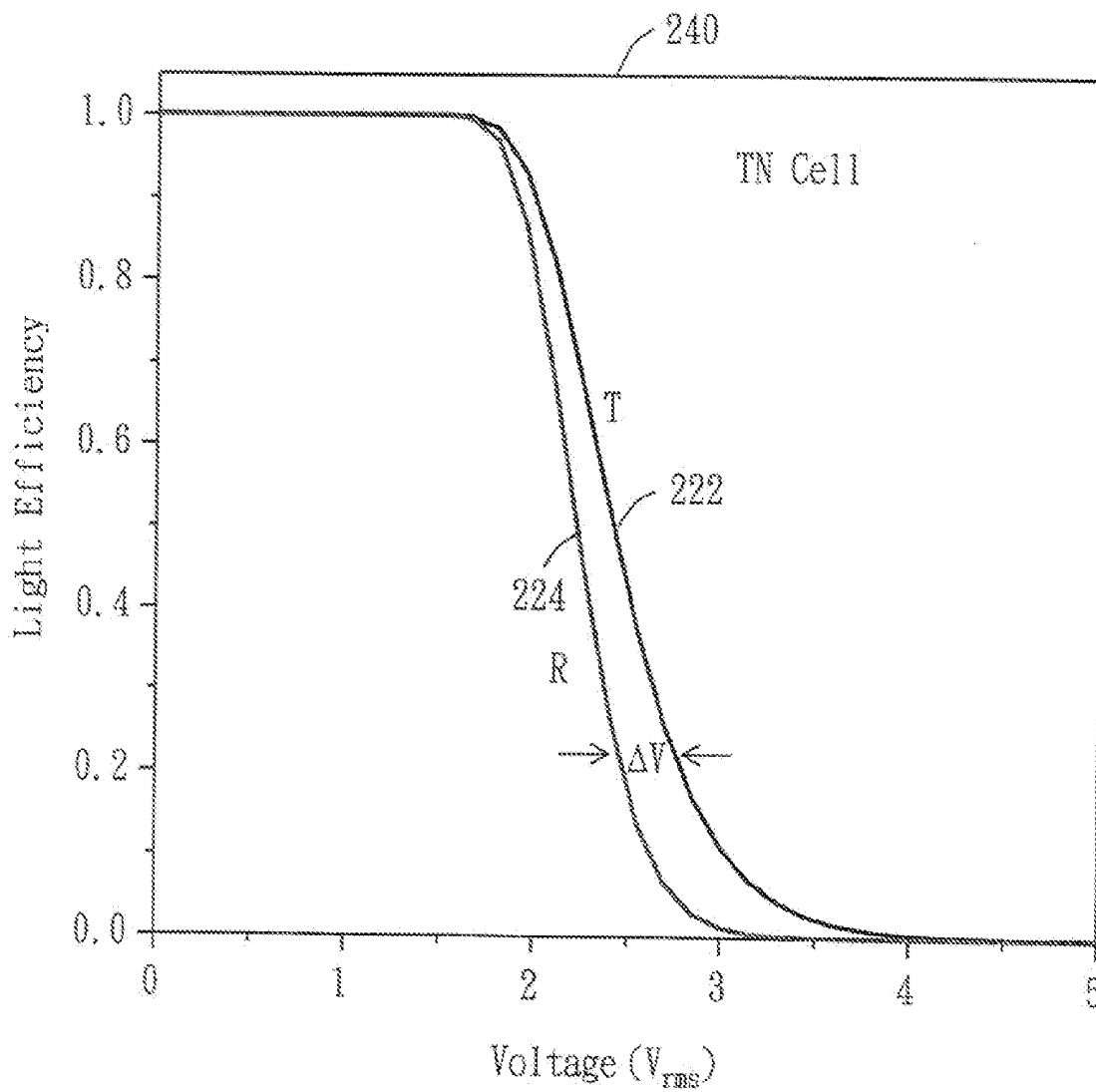

FIG. 14

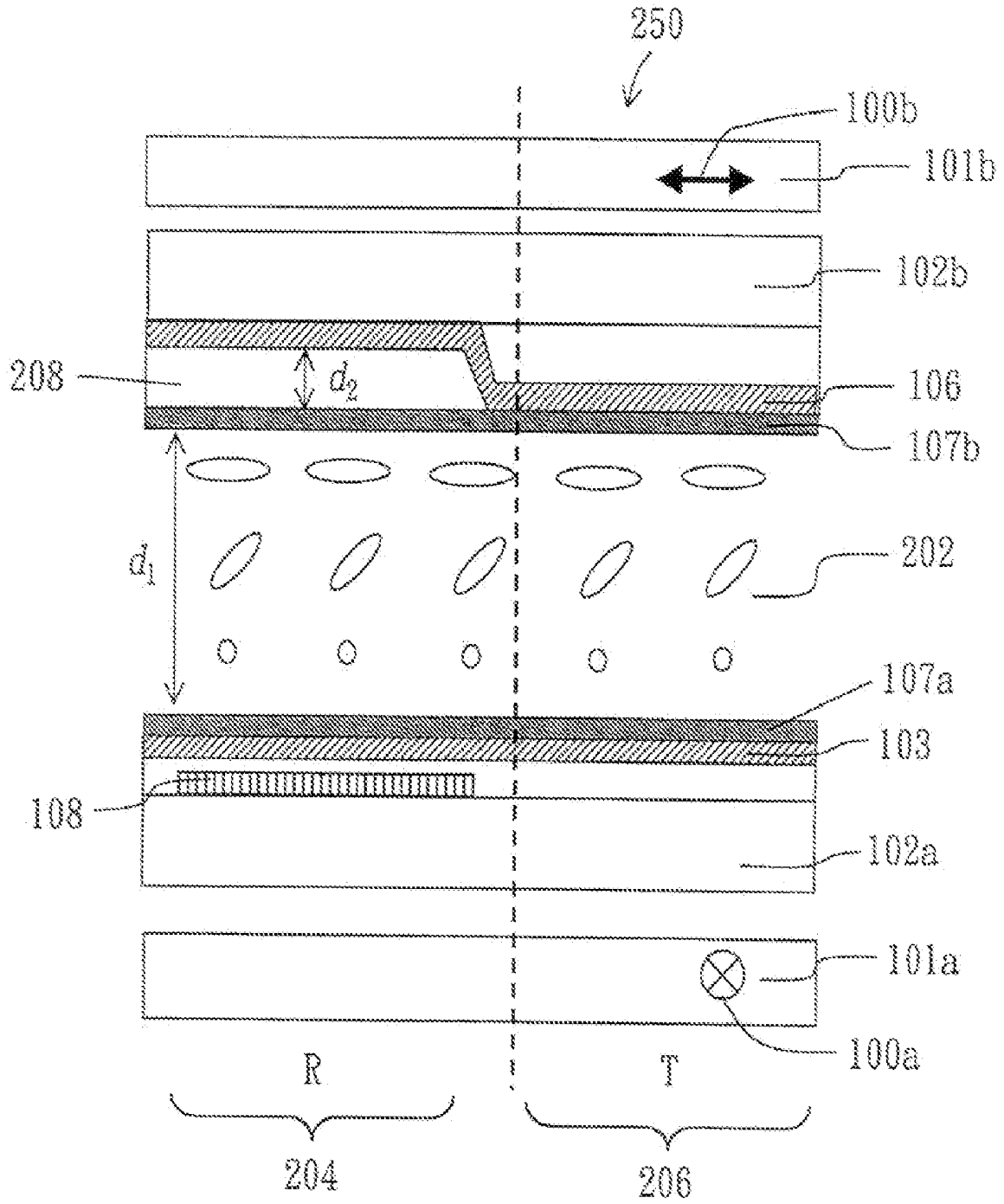

FIG. 15

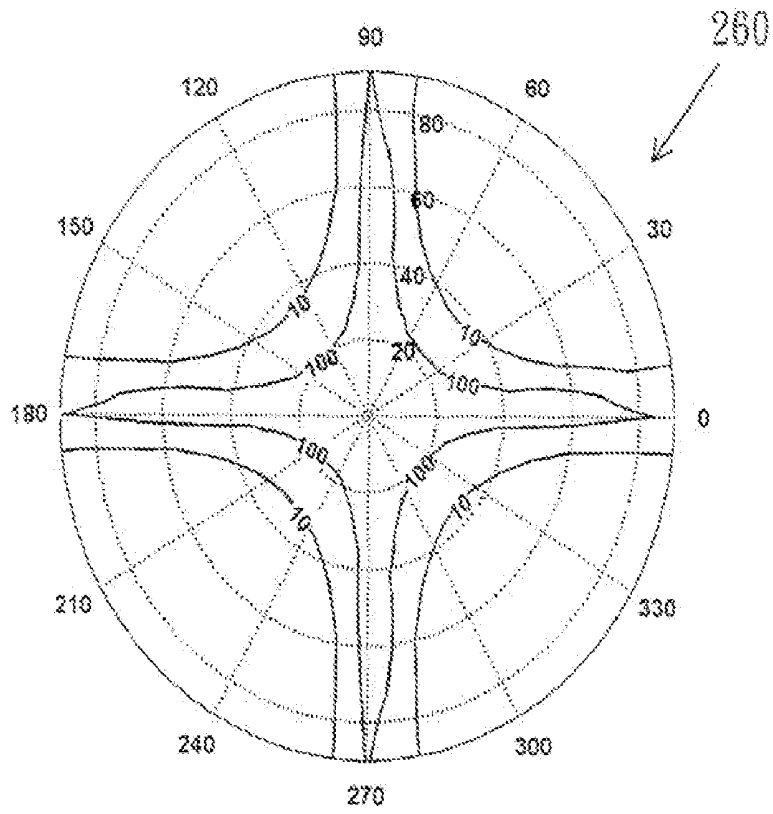

FIG. 16A

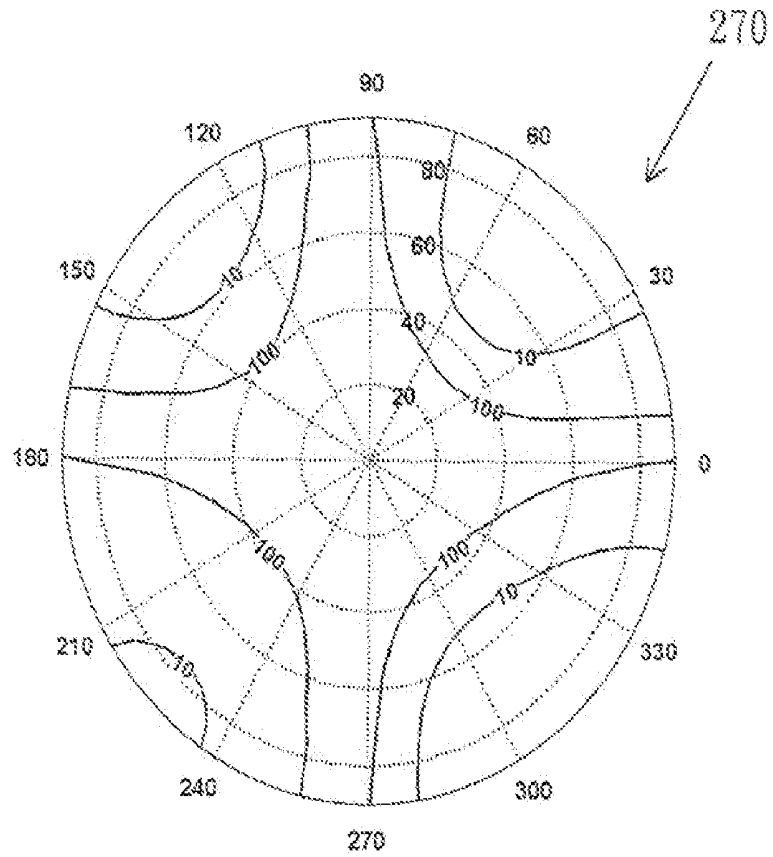

FIG. 16B

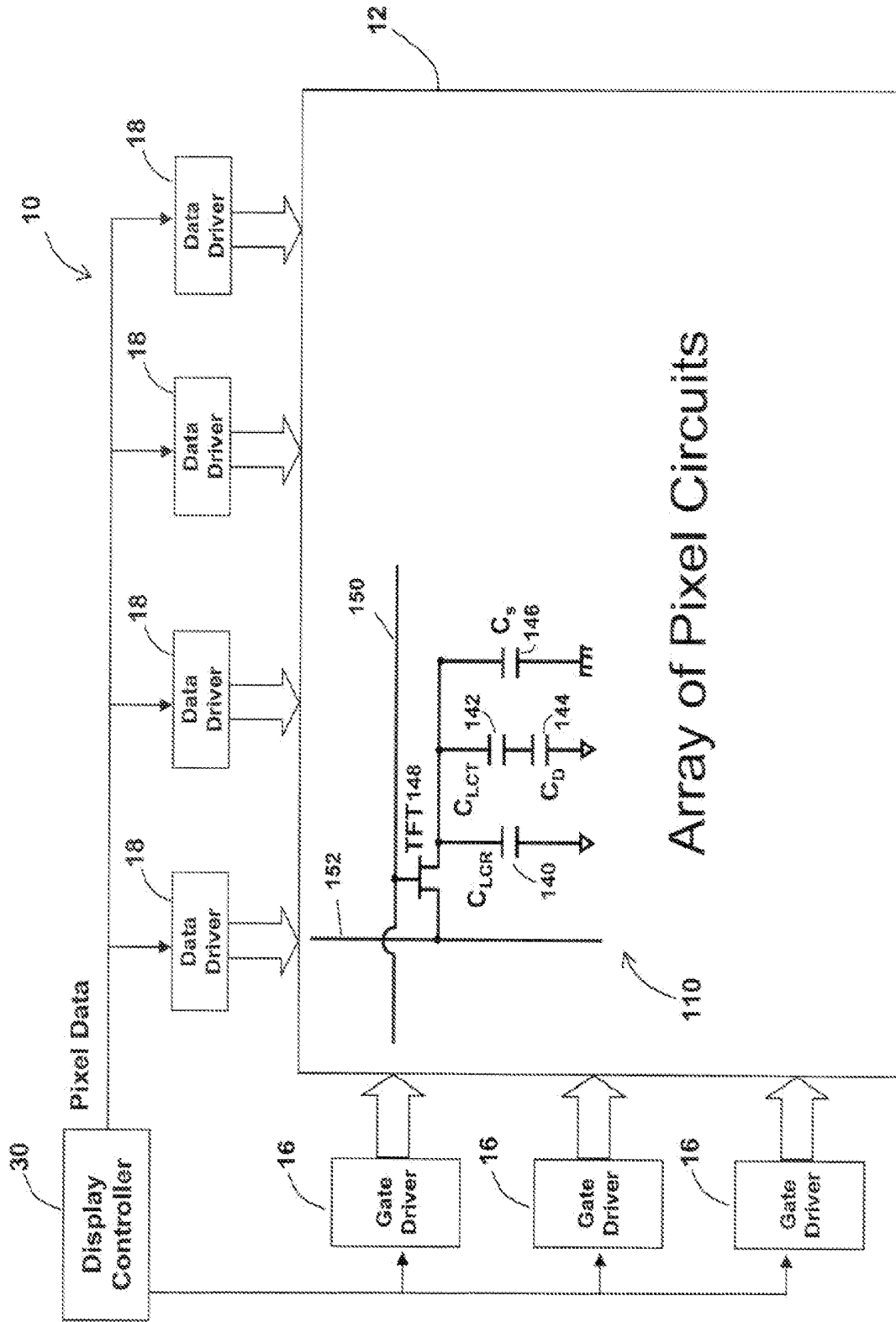

FIG. 17

## TRANSFLECTIVE LIQUID CRYSTAL DISPLAY

### BACKGROUND OF THE INVENTION

**[0001]** The description relates to transflective liquid crystal displays.

**[0002]** Liquid crystal displays (LCD) include transmissive type, reflective type, and transflective type displays. A transmissive type LCD includes a backlight module to generate light that is modulated by liquid crystal cells to generate images. The transmissive type LCD can have a high contrast ratio and good color saturation. A reflective type LCD includes a reflector to reflect ambient light that is modulated by liquid crystal cells to generate images. The reflective type LCD does not require a backlight module, and is useful in environments with strong ambient light. A transflective type LCD can operate in a transmissive mode and/or a reflective mode. In one example, each pixel of the transflective LCD is divided into a transmissive part (T sub-pixel) and a reflective part (R sub-pixel). When operating in the transmissive mode, a backlight module generates light that is modulated by the T sub-pixels. When operating in the reflective mode, reflected ambient light is modulated by the R sub-pixels.

### SUMMARY

**[0003]** In one general aspect, a transflective liquid crystal display achieves good gray scale gamma curve match between transmissive and reflective modes by using an internal wire grid polarizer and a voltage shield capacitor in one of the transmissive or reflective sub-pixels depending on the liquid crystal mode. In some examples, the display does not use broadband circular polarizers, and can have wide viewing angles and high contrast ratios (e.g., a contrast ratio greater than 100:1 at 40 degree viewing angle for most directions).

**[0004]** In another general aspect, a display includes a plurality of pixel circuits, each pixel circuit including a first electrode, a second electrode, a reflective region, and a transmissive region. The reflective region reflects ambient light and includes a first portion of a liquid crystal layer between the first and second electrodes, and a polarization dependent reflector that transmits light having a first polarization and reflects light having a second polarization. The transmissive region transmits backlight and includes a second portion of the liquid crystal layer between the first and second electrodes. A dielectric layer is between the first and second electrodes in one of the reflective region and the transmissive region, the dielectric layer configured such that when a pixel voltage is applied to the first and second electrodes, the percentage of the pixel voltage applied across the first portion of the liquid crystal layer is different from the percentage of the pixel voltage applied across the second portion of the liquid crystal layer. The display includes a backlight module to generate the backlight.

**[0005]** Implementations of the display may include one or more of the following features. The polarization dependent reflector includes a wire grid polarizer. In some examples, the dielectric layer is in the reflective region and configured such that when the pixel voltage is applied to the first and second electrodes, the percentage of the pixel voltage applied across the first portion of the liquid crystal layer is lower than the percentage of the pixel voltage applied across the second portion of the liquid crystal layer. The liquid crystal layer is between two substrates, and the liquid crystal layer includes

liquid crystal molecules that are substantially aligned along a direction parallel to the surfaces of the substrates when no voltage is applied to the first and second electrodes. In some examples, the dielectric layer is in the transmissive region and configured such that when the pixel voltage is applied to the first and second electrodes, the percentage of the pixel voltage applied across the first portion of the liquid crystal layer is higher than the percentage of the pixel voltage applied across the second portion of the liquid crystal layer. The liquid crystal layer is between two substrates, and the liquid crystal layer includes liquid crystal molecules that are substantially aligned along a direction normal to the substrates when no voltage is applied to the first and second electrodes.

**[0006]** The dielectric layer has a dielectric constant and a thickness that are selected to reduce a difference between a transmittance of the transmissive region and a reflectance of the reflective region for a given pixel voltage applied to the first and second electrodes. The dielectric layer functions as a capacitor that is connected in series with the liquid crystal layer between the first and second electrodes. The dielectric layer includes at least one of silicon oxide and silicon nitride. At least one of the first electrode and the second electrode includes at least one of indium tin oxide, indium zinc oxide, and gallium zinc oxide. The display includes a first linear polarizer and a second linear polarizer that both extend over the transmissive and reflective regions, the first and second linear polarizers being at different sides of the liquid crystal layer. The first linear polarizer is closer to a viewer than the second linear polarizer, and the polarization dependent reflector has a reflective axis that is perpendicular to a transmission axis of the first linear polarizer. The liquid crystal layer is between two substrates, and the liquid crystal layer includes liquid crystal molecules that are substantially aligned along a direction normal to the substrates when no voltage is applied to the first and second electrodes. In some examples, the liquid crystal layer includes a negative dielectric anisotropic liquid crystal material. In some examples, the liquid crystal layer includes a positive dielectric anisotropic liquid crystal material.

**[0007]** In another general aspect, a display includes a first substrate, a second substrate, and pixel circuits between the first and second substrates. Each pixel circuit has a transmissive portion and a reflective portion. Each pixel circuit includes a first electrode, a second electrode, a liquid crystal cell, a polarization dependent reflector located at the reflective portion, and a shield capacitor located at one of the reflective and transmissive portions and positioned in series with the liquid crystal cell.

**[0008]** Implementations of the display may include one or more of the following features. The shield capacitor is configured to cause a gray scale gamma curve of the transmissive region to more closely match a gray scale gamma curve of the reflective region, as compared to the pixel circuit without the shield capacitor. In some examples, the pixel circuits are in dark states when no pixel voltage is applied to the pixel circuits. In some examples, the pixel circuits are in bright states when no pixel voltage is applied to the pixel circuits.

**[0009]** In another general aspect, a transflective display includes a first linear polarizer having a first transmission axis, a second linear polarizer having a second transmission axis, the first linear polarizer located closer to a front side of the display than the second linear polarizer, and pixel circuits. Each pixel circuit includes a liquid crystal layer between the first and second linear polarizers, the liquid crystal layer

having a first portion and a second portion, the first portion corresponding to a reflective portion of the pixel circuit, the second portion corresponding to a transmissive portion of the pixel circuit. Each pixel circuit includes a storage capacitor to store an electric charge corresponding to a pixel voltage and a polarization dependent reflector that is associated with the first portion of the liquid crystal layer. The polarization dependent reflector reflects a first component of external light and transmits a second component of the external light, the first component having a first polarization substantially perpendicular to the first transmission axis and the second component having a second polarization substantially parallel to the first transmission axis. Each pixel circuit includes means for applying a first percentage of the pixel voltage to the first portion of the liquid crystal layer and a second percentage of the pixel voltage to the second portion of the liquid crystal layer, the first percentage being different from the second percentage.

**[0010]** Implementations of the transfective display may include one or more of the following features. The means for applying the first and second percentages of the pixel voltage is configured to cause the transmissive portion to have a transmittance-voltage characteristic that more closely matches a reflectance-voltage characteristic of the reflective portion, as compared to a pixel circuit that applies the same percentage of the pixel voltage to the first and second portions of the liquid crystal layer.

**[0011]** In another general aspect, a method includes reflecting external light having a first polarization after the external light passes a liquid crystal layer in a reflective region of a pixel of a display, the reflected light being directed toward a viewer of the display. The method includes transmitting external light having a second polarization after the external light passes the liquid crystal layer in the reflective region, the transmitted light being directed away from the viewer, and transmitting backlight through the liquid crystal layer in a transmissive region of the pixel, the transmitted light being directed toward the viewer. The method includes applying a first percentage of a pixel voltage to the liquid crystal layer in the reflective region, and applying a second percentage of the pixel voltage to the liquid crystal layer in the transmissive region, the second percentage being different from the first percentage.

**[0012]** Implementations of the method may include one or more of the following features. The first and second percentages are configured to cause the transmittance of the transmissive region to more closely match the reflectance of the reflective region for a given pixel voltage, as compared to applying a same percentage of the pixel voltage to the reflective and transmissive regions. In some examples, the method includes showing a dark state at the pixel when the pixel voltage is below a threshold. In some examples, the method includes showing a bright state at the pixel when the pixel voltage is below a threshold. In some examples, the method includes aligning liquid crystal molecules of the liquid crystal layer along directions substantially normal to surfaces of two substrates when no voltage is applied to the first and second electrodes, the liquid crystal layer being positioned between the two substrates. In some examples, the method includes aligning liquid crystal molecules of the liquid crystal layer along directions substantially parallel to surfaces of two substrates when no voltage is applied to the first and second electrodes, the liquid crystal layer being positioned between the two substrates.

**[0013]** In another general aspect, a method includes forming a polarization dependent reflector in a first region of first substrate, the first region corresponding to a reflective region of a pixel of a display, forming a first electrode on the first substrate, and forming a second electrode on a second substrate. The method includes forming a dielectric layer on a portion of the first electrode or a portion of the second electrode, the dielectric layer corresponding to either the reflective region of the pixel or a transmissive region of the pixel, and providing a liquid crystal layer between the first and second substrates, the dielectric layer being positioned in series with the liquid crystal layer between the first and second electrodes.

**[0014]** Implementations of the method may include one or more of the following features. In some examples, the method includes providing alignment layers on the first and second substrates to cause the liquid crystal molecules of the liquid crystal layer to substantially align along a direction normal to the surfaces of the substrates when no voltage is applied to the first and second electrodes. In some examples, the method includes providing alignment layers on the first and second substrates to cause the liquid crystal molecules of the liquid crystal layer to substantially align along a direction parallel to the surfaces of the substrates when no voltage is applied to the first and second electrodes. The method includes providing a first linear polarizer at a side of the first substrate facing away from the liquid crystal layer, and providing a second linear polarizer at a side of the second substrate facing away from the liquid crystal layer, the first linear polarizer having a transmission axis that is non-parallel to a transmission axis of the second linear polarizer.

#### DESCRIPTION OF DRAWINGS

**[0015]** FIG. 1 is a diagram of a transfective liquid crystal display.

**[0016]** FIG. 2 is a diagram of a wire grid polarizer.

**[0017]** FIGS. 3A and 3B are cross-sectional diagrams of a VA mode transfective liquid crystal display.

**[0018]** FIG. 4 is a diagram of an equivalent circuit.

**[0019]** FIG. 5 is a diagram of capacitances.

**[0020]** FIGS. 6 and 7 are graphs of voltage-reflectance and voltage-transmittance characteristics.

**[0021]** FIG. 8 is a cross-sectional diagram of a VA mode transfective liquid crystal display.

**[0022]** FIG. 9 is a cross-sectional diagram of a VA mode transfective liquid crystal display.

**[0023]** FIGS. 10, 11A, and 11B are cross-sectional diagrams of a TN mode transfective liquid crystal display.

**[0024]** FIG. 12 is a diagram of an equivalent circuit.

**[0025]** FIGS. 13 and 14 are graphs showing voltage-reflectance and voltage-transmittance characteristics.

**[0026]** FIG. 15 is a cross-sectional diagram of a TN mode transfective liquid crystal display.

**[0027]** FIGS. 16A and 16B are iso-contrast plots.

**[0028]** FIG. 17 is a block diagram of a liquid crystal display.

#### DETAILED DESCRIPTION

**[0029]** FIG. 1 is a cross-sectional diagram of an example of a transfective liquid crystal display 100 that includes a vertically aligned liquid crystal layer 104 positioned between a lower glass substrate 102a and an upper glass substrate 102b. A lower linear polarizer 101a is attached to an outer side of the lower substrate 102a, and an upper linear polarizer 101b

is attached an outer side of the upper substrate **102b**. The lower linear polarizer **101a** has a transmission axis **100a** that is perpendicular to the transmission axis **100b** of the upper polarizer **101b**. An upper transparent electrode **106** (which functions as a common electrode) and an upper alignment layer **107b** are positioned on an inner side of the upper substrate **102b**. On an inner side of the lower substrate **102a** are a wire grid polarizer **108**, passivation layer **105**, a lower transparent electrode **103** (which functions as a pixel electrode), and a lower alignment layer **107a**. The lower and upper alignment layers **107a** and **107b** are used to align liquid crystal molecules **128** in the liquid crystal layer **104**. A backlight module **116** provides backlight when the display **100** is used in the transmissive mode.

[0030] In this description, the terms “upper” and “lower” refer to relative positions of the components of the display **100**. An upper layer is closer to the viewer than a lower layer.

[0031] The transparent electrodes **103** and **106** can be made of, e.g., indium tin oxide (ITO), indium zinc oxide (IZO), and gallium zinc oxide (GZO). The alignment layers **107a** and **107b** can be made of, e.g., polyimide materials.

[0032] The display **100** includes an array of pixels **110**, one of which is shown in FIG. 1. The pixel **110** includes a reflective (R) sub-pixel **112** and a transmissive (T) sub-pixel **114**. The wire grid polarizer **108** is a reflective type polarizer or a polarization-dependent reflector, and is located in the R sub-pixel **112**. The wire grid polarizer **108** includes metal strips **120** (see FIG. 2) formed on the lower substrate **102a**. The metal strips **120** extend along a direction **138** (referred to as the lengthwise direction of the metal strips **120**). In this example, the lengthwise direction **138** of the metal strips **120** is perpendicular to the transmission axis **100b** of the upper linear polarizer **101b**.

[0033] The wire grid polarizer **108** has a transmission axis that is perpendicular to the lengthwise direction **138** of the metal strips **120** and a reflection axis that is parallel to the lengthwise direction **138** of the metal strips **120**. When an unpolarized incident light **122** (FIG. 2) impinges on the surface of the wire grid polarizer **108**, a first component of the light **124** (FIG. 2) having a polarization parallel to the lengthwise direction of the metal strips **120** is reflected, and a second component of the light **126** (FIG. 2) having a polarization perpendicular to the metal strips passes through the wire grid polarizer **108**.

[0034] Each pixel **110** includes a storage capacitor  $C_S$  (see FIGS. 4 and 17) for storing a pixel voltage, and a thin film transistor (FIGS. 4 and 17) for driving the storage capacitor  $C_S$ . Within each pixel **110**, the thin film transistor, the storage capacitor, the upper electrode **106**, the liquid crystal layer **104**, the lower electrode **103**, the wire grid polarizer **108**, and the dielectric layer **105** are collectively referred to as a pixel circuit **14** (FIGS. 4 and 17). The pixel circuits **14** can be individually addressed by using gate lines **150** and data lines **152** (FIGS. 4 and 17). The linear polarizers **101a** and **101b**, the glass substrates **102a** and **102b**, the alignment layers **107a** and **107b**, and the liquid crystal layer **104** extend over several pixels **110**.

[0035] In the T sub-pixel **114**, the passivation layer **105** having a thickness  $d_2$  is positioned between the lower transparent ITO electrode **103** and the lower alignment layer **107a**. In the R sub-pixel **112**, the lower electrode **103** is directly adjacent to the lower alignment layer **107a**. When a pixel voltage  $V_{DATA}$  is applied to the lower and upper electrodes **103** and **106** (i.e., generating a voltage difference equal to

$V_{DATA}$  between the lower and upper electrodes), the percentages of the pixel voltage  $V_{DATA}$  applied to the liquid crystal layer **104** in the R and T sub-pixels **112** and **114** are different.

[0036] In the R sub-pixel **112**, substantially all of the pixel voltage  $V_{DATA}$  is applied to the liquid crystal layer **104**. In the T sub-pixel **114**, the pixel voltage  $V_{DATA}$  is applied to both the liquid crystal layer **104** and the passivation layer **105**, so the percentage of the pixel voltage  $V_{DATA}$  applied to the liquid crystal layer **104** in the T sub-pixel **114** is less than that in the R sub-pixel **112**. The passivation layer **105** functions as a shield capacitor that reduces the amount of pixel voltage applied to the liquid crystal layer **104** in the T sub-pixel **114**.

[0037] Referring to FIG. 2, the wire grid polarizer **108** includes metal strips **120** aligned in a direction parallel to the transmission axis **100a** of the lower polarizer **101a**. In some examples, each metal strip **120** has a thickness  $t$  and a width  $w$ , and the spacing between the metal strips **120** is  $p$ . When unpolarized incident light **122** is directed towards the surface of the wire grid polarizer **108**, a first component **124** of the light **122** having a polarization parallel to the lengthwise direction of the metal strips **120** is reflected, and a second component **126** of the light **122** having a polarization perpendicular to the lengthwise direction of the metal strips **120** passes through the wire grid polarizer **108**.

[0038] The following describes operation of the pixel **110** during the dark and bright states. If the display **100** uses gray scale levels ranging from 0 to 255, the dark state corresponds to the gray scale level 0, and the bright state corresponds to the gray scale level 255.

[0039] Referring to FIG. 3A, when no voltage is applied to the lower and upper electrodes **103** and **106**, the liquid crystal molecules **128** are aligned in the vertical direction. In the T sub-pixel **114**, backlight **118** from the backlight module **116** passes the lower linear polarizer **101a** and becomes linearly polarized light **132** having a polarization direction parallel to the transmission axis **100a** of the lower linear polarizer **101a**. The linearly polarized light **132** passes the liquid crystal layer **104** without changing its polarization, and is blocked by the upper polarizer **101b**.

[0040] In the R sub-pixel **112**, incident ambient light **130** first passes the upper polarizer **101b** and becomes linearly polarized light **134** having a polarization parallel to the transmission axis **100b** of the upper polarizer **101b**. The linearly polarized light **134** maintains its polarization after passing the liquid crystal layer **104**. Because the linearly polarized light **134** has a polarization perpendicular to the metal strips **120** of the wire grid polarizer **108**, the linearly polarized light **134** passes the wire grid polarizer **108** and is absorbed by the lower polarizer **101a**.

[0041] Referring to FIG. 3B, when a pixel voltage  $V_{DATA} = V_{BRIGHT}$  that corresponds to a bright state is applied to the electrodes **103** and **106**, the liquid crystal molecules **128** are rotated by an electric field. The pixel voltage  $V_{BRIGHT}$  for the bright state is selected such that the liquid crystal layer **104** becomes similar to a half-wave plate.

[0042] In this description, when a layer or film is said to behave similar to a half-wave plate, it means that the layer or film behave similar to a half-wave plate for a specified wavelength, e.g., 589 nm. Similarly, when a layer or film is said to behave similar to a quarter-wave plate, it means that the layer or film behave similar to a quarter-wave plate for the specified wavelength.

[0043] In the R sub-pixel **112**, the polarization of the linearly polarized light **134** is rotated by 90 degrees as the light

**134** passes the liquid crystal layer **104**, and becomes parallel to the lengthwise direction of the metal strips **120** of the wire grid polarizer **108**. The light is reflected by the wire grid polarizer **108** back to the liquid crystal layer **104** as reflected light **136**. After the reflected light **136** passes the liquid crystal layer **104**, its polarization is rotated again by 90 degrees to become parallel to the transmission axis **100b** of the upper polarizer **101b**. The reflected light **136** passes the upper polarizer **101b** and is seen by the user as a bright R sub-pixel **112**.

**[0044]** In the T sub-pixel **114**, as the linearly polarized light **132** passes the liquid crystal layer **104**, the polarization of the light **132** is rotated by 90 degrees so that the polarization is parallel to the transmission axis **100b** of the upper polarizer **101b**. The light passes the upper polarizer **101b** and is seen by the user as a bright T sub-pixel **114**.

**[0045]** Although the passivation layer **105** causes the percentage of the pixel voltage applied to the R and T sub-pixels **112** and **114** to be different, the pixel voltage  $V_{BRIGHT}$  is selected to be sufficiently high so that the liquid crystal molecules **128** in both the R and T sub-pixels **112** and **114** are substantially parallel to the surface of the substrates **102a** and **102b**. The cell gap  $d_1$  of the liquid crystal layer **104** is selected such that when the liquid crystal molecules **128** are substantially aligned parallel to the substrates **102a** and **102b**, the liquid crystal layer **104** behaves similar to a half wave plate.

**[0046]** In designing the display **100**, the cell gap  $d_1$  of the liquid crystal layer **104** and the liquid crystal material are selected such that  $\Delta n \cdot d_1 = \lambda/2$  so that the liquid crystal layer **104** behaves similar to a half-wave plate in the bright state. The parameter  $\Delta n$  equals  $n_e - n_o$ , where  $n_e$  and  $n_o$  are the extraordinary and ordinary refractive indices, respectively, of the liquid crystal material. In some examples,  $\Delta n \cdot d_1$  is selected to be slightly larger than  $\lambda/2$  because there may be a small amount of phase loss at boundaries of the liquid crystal layer, and a higher  $\Delta n \cdot d_1$  allows the bright state to be achieved at a lower pixel data voltage. Selection of the liquid crystal material may take into consideration factors such as a large  $\Delta n$  value to reduce the required cell gap, a high dielectric anisotropy ( $\Delta\epsilon$ ) to reduce the on-state driving voltage, and a low viscosity to reduce the response time.

**[0047]** When the pixel voltage corresponds to a gray scale voltage between the dark state and the bright state (e.g., a gray scale level between 0 and 255), the percentages of the pixel voltage  $V_{DATA}$  applied to the R sub-pixel **112** and the T sub-pixel **114** are different, as described below.

**[0048]** FIG. 4 shows a diagram of an equivalent circuit of the pixel **110** in FIG. 1. When the voltage on a gate line **150** is pulled high, the thin film transistor **148** of the pixel **100** is turned on, allowing the pixel voltage  $V_{DATA}$  on a data line **152** to charge a storage capacitor  $C_s$  (**146**) to the pixel voltage  $V_{DATA}$ . In this example, the TFT **148** is an N-type transistor. The portion of the liquid crystal layer **104** in the R sub-pixel **112** has an effective capacitance that is represented by a capacitor  $C_{LCR}$  (**140**). The portion of the liquid crystal layer **104** in the T sub-pixel **114** has an effective capacitance that is represented by a capacitor  $C_{LCT}$  (**142**). The passivation layer **105** is made of a dielectric material and has an effective capacitance represented by a capacitor  $C_D$  (**144**). The pixel voltage  $V_{DATA}$  is substantially fully applied to the liquid crystal layer **104** in the R sub-pixel **112**. By comparison, because  $C_D$  is connected in series with  $C_{LCT}$ , only a portion of the pixel voltage  $V_{DATA}$  is applied to the portion of the liquid crystal layer **104** in the T sub-pixel **114**.

**[0049]** Referring to FIG. 5, the capacitances  $C_{LCT}$  and  $C_D$  of the liquid crystal layer **104** and the passivation layer **105**, respectively, in the T sub-pixel are approximately equal to

$$C_{LCT} = \frac{\epsilon_{LC}}{d_1} \text{ and } C_D = \frac{\epsilon_D}{d_2},$$

respectively. If the voltage applied to the liquid crystal layer **104** in the R sub-pixel **112** and T sub-pixel **114** are denoted  $V_R$  and  $V_T$ , respectively, then

$$V_T = \frac{C_D}{C_D + C_{LCT}} V_R. \quad (\text{Equ. 1})$$

**[0050]** FIG. 6 is a graph **160** showing a curve **162** that represents the voltage-reflectance characteristics of the R sub-pixel **112**. Also shown are curves **164**, **166**, **168**, and **170** representing the voltage-transmittance characteristics of the T sub-pixel **114** when the passivation layer **105** has a thickness of 0, 350 nm, 500 nm, and 700 nm, respectively. The horizontal axis represents the voltage applied to the electrodes **103** and **106**, which is equal to the voltage  $V_R$  applied to the R sub-pixel **112**. The data points for the graph **160** were obtained using simulation. When the thickness  $d_2$  of the passivation layer **105** is equal to 350 nm, the curve **162** more closely matches the curve **166** (as compared to the curve **164** versus curve **166**), indicating that the voltage-reflectance characteristic of the R sub-pixel **112** more closely matches the voltage-transmittance characteristic of the T sub-pixel **114**. The R sub-pixel **112** and the T sub-pixel **114** will show similar gray scale (or color) for a given pixel voltage  $V_{DATA}$ .

**[0051]** In the simulations used to obtain the data for the graph **160**, the liquid crystal material used was MLC-6608, available from Merck, Japan. The liquid crystal material has a parallel dielectric constant  $\epsilon_{\parallel} = 3.6$ , perpendicular dielectric constant  $\epsilon_{\perp} = 7.8$ , and elastic constants  $K_{11} = 16.7$  pN,  $K_{22} = 7.0$  pN, and  $K_{33} = 18.1$  pN. The liquid crystal material has an extraordinary refractive index  $n_e = 1.5578$  and an ordinary refractive index  $n_o = 1.4748$  at  $\lambda = 589$  nm. The parameter  $d_1 \cdot \Delta n$  of the liquid crystal layer **104** is set at  $0.36 \mu\text{m}$ . The passivation layer **105** can be made of dielectric materials (e.g.,  $\text{SiO}_2$ , which has a dielectric constant of 3.9) that are compatible with the thin film transistor fabrication process.

**[0052]** The thickness of the passivation layer **105** can be estimated using a voltage shifting method. FIG. 7 is a graph **180** that shows the curves **162** and **164** of FIG. 6. The curves **162** and **164** represent the voltage reflectance characteristics of the R sub-pixel **112** and the voltage-transmittance characteristics of the T sub-pixel **114**, respectively, when the passivation layer **105** has a thickness  $d_2 = 0$ . If the curve **164** is shifted towards the right of the figure, the curves **162** and **164** will more closely match each other. This means that for a given gray scale, the voltage level applied to the T sub-pixel **114** should be lower by a certain amount  $\Delta V$  than the voltage level applied to the R sub-pixel **112**.

**[0053]** The differences in the V-R curve **162** and V-T curve **164** in FIG. 7 may be caused by the loss of light in the R sub-pixel **112** when the pixel voltage  $V_{DATA}$  corresponds to a gray scale between the dark and bright states. Referring to FIG. 8, when the pixel voltage  $V_{DATA}$  is at a level such that the phase retardation from the liquid crystal layer **104** is less than

that from a half-wave plate, the linearly polarized light **134** will become elliptically polarized when the light **134** reaches the surface of the wire grid polarizer **108**. A portion of the light **134** (the component of the light perpendicular to the metal stripes **120**) passes the wire grid polarizer **108** and is absorbed by the lower polarizer **101a**. Thus, the amount of light **136** reflected by the wire grid polarizer **108** is less than the backlight **132** that passed the linear polarizer **101a**. This accounts for the lower luminance in the R sub-pixel **112** compared to the T sub-pixel **114** for a given pixel voltage  $V_{DATA}$ .

[0054] The amount of capacitance  $C_D$  that is need to achieve an amount of voltage shift so that the V-R curve **162** more closely matches the V-T curve **164** can be determined as follows. Referring back to FIG. 7, assume for a given light efficiency, the voltage applied to the liquid crystal layer **104** in the R sub-pixel is  $V_R$ , and the voltage applied to the liquid crystal layer **104** in the T sub-pixel is  $V_T$ , and  $V_R = V_T + \Delta V$ .

[0055] Replacing  $V_R$  with  $V_T + \Delta V$  in Equ. 1, the following can be obtained:

$$V_T = \frac{C_D}{C_D + C_{LCT}} (V_T + \Delta V). \quad (\text{Equ. 2})$$

In Equ. 2,

[0056]

$$C_D = \frac{\epsilon_D}{d_2} \text{ and } C_{LCT} = \frac{\epsilon_{LC}}{d_1}.$$

The dielectric constants  $\epsilon_D$  and  $\epsilon_{LC}$  are determined by the material used for the passivation layer **105** and the liquid crystal layer **104**. The dielectric constant  $\epsilon_{LC}$  is a value between  $\epsilon_{||}$  and  $\epsilon_{\perp}$  based on the liquid crystal director distribution at different gray levels. For example, when the liquid crystal molecules are mostly aligned perpendicular to the substrates,  $\epsilon_{LC}$  is close to  $\epsilon_{\perp}$ , and when the molecules are mostly aligned parallel to the substrates, then  $\epsilon_{LC}$  is close to  $\epsilon_{||}$ . The thickness  $d_1$  of the liquid crystal material is selected such that the liquid crystal layer **104** behaves like a half wave plate in the bright state. In this example,  $n_e = 1.5578$  and  $n_o = 1.4748$  at  $\lambda = 589$  nm, and  $d_1 \cdot \Delta n$  of the liquid crystal layer **104** is set at  $0.36 \mu\text{m}$ , so  $d_1 = 4.34 \mu\text{m}$ .

[0057]  $V_T$  and  $\Delta V$  can be selected from any point on the curve **164**. For example, the threshold voltage (at point P on curve **164**) of the T sub-pixel is approximately 2.1 V, and the threshold voltage (at point Q on curve **162**) of the R sub-pixel is approximately 2.4 V, so  $\Delta V$  is approximately 0.3V. When the values for  $V_T = 2.1$  V,  $\Delta V = 0.3$  V,  $d_1 = 4.34 \mu\text{m}$ ,  $\epsilon_D = 3.9$ , and  $\epsilon_{LC} \sim 3.6$  are used in Equ. 2, it can be determined that  $d_2$  is approximately 670 nm, which approximately matches the value  $d_2 = 700$  nm determined by simulations shown in FIG. 6 when the matching point (the point where the V-R curve matches the V-T curve) is set at  $V_T = 2.1$  V or  $V_R = 2.4$  V (point P or Q, respectively, in FIG. 7). In FIG. 6, the V-R curve **162** matches the V-T curve **170** (representing  $d_2 = 700$  nm) at  $V_R = 2.4$  V, corresponding to a transmittance and a reflectance about zero. In order for the V-T and V-R curves to match each other at an intermediate gray level, the thickness of the  $d_2$  can be adjusted to a smaller value, such as 350 nm. For

example, in FIG. 6, the V-R curve **162** matches the V-T curve **166** (representing  $d_2 = 350$  nm) at  $V_R = 3.5$  V, corresponding to a transmittance and reflectance of about 60%.

[0058] FIG. 9 is a cross-sectional diagram of an example of a transfective liquid crystal display **190** that is similar to the transfective liquid crystal display **100** of FIG. 1. The difference between displays **100** and **190** is that in the T sub-pixel **114** of the display **190**, the passivation layer **105** is positioned between the upper electrode **106** and the upper alignment layer **107b**. The lower electrode **103** is directly adjacent to the lower alignment layer **107a**. In the display **190**, similar to the display **100**, when a pixel voltage  $V_{DATA}$  is applied to the electrodes **103** and **106**, the percentage of the pixel voltage  $V_{DATA}$  applied to the liquid crystal layer **104** in the R sub-pixel **112** is higher than that in the T sub-pixel **114**.

[0059] FIG. 10 is a cross-sectional diagram of an example of a transfective liquid crystal display **200** that includes a twisted nematic type liquid crystal layer **202** positioned between a lower glass substrate **102a** and an upper glass substrate **102b**. FIG. 10 shows a pixel **202** that includes a R sub-pixel **204** and a T sub-pixel **206**. The display **200** has a lower linear polarizer **101a**, an upper linear polarizer **101b**, a wire grid polarizer **108**, a lower alignment layer **107a**, an upper alignment layer **107b**, and an upper transparent electrode **106**, similar to those in the display **100** of FIG. 1.

[0060] In the display **200**, in the R sub-pixel **204**, a passivation layer **208** is positioned between the lower electrode **103** and the lower alignment layer **204**. In the T sub-pixel **206**, the lower electrode **103** is directly adjacent to the lower alignment layer **107a**. When a pixel voltage  $V_{DATA}$  is applied to the electrodes **103** and **106**, all of the pixel voltage  $V_{DATA}$  is applied to the liquid crystal layer **202** in the T sub-pixel **206**, and a lower percentage of the pixel voltage  $V_{DATA}$  is applied to the liquid crystal layer **202** in the R sub-pixel **204**.

[0061] When no voltage is applied to the electrodes **103** and **106**, the liquid crystal molecules **128** of the liquid crystal layer **202** are substantially parallel to the surface of the substrates **101a** and **101b**. The directors of the liquid crystal molecules **128** are oriented at different directions depending on the position of the molecules **128**. The liquid crystal molecules **128** form a twisted structure in which the molecules **128** rotate 90 degrees from a position adjacent to the lower alignment layer **107a** to a position adjacent to the upper alignment layer **107b**. The liquid crystal molecules **128** adjacent to the lower alignment layer **107a** are aligned substantially parallel to the transmission axis **100a** of the lower linear polarizer **101a**, and liquid crystal molecules **128** adjacent to the upper alignment layer **107b** are aligned substantially parallel to the transmission axis **100b** of the upper linear polarizer **101b**.

[0062] When a pixel voltage  $V_{DATA} = V_{DARK}$  corresponding to a dark state is applied to the electrodes **103** and **106**, the liquid crystal molecules **128** of the liquid crystal layer **202** are tilted by the electric field generated by the pixel voltage  $V_{DATA}$ . The level of the pixel voltage for the dark state is selected such that the liquid crystal molecules **128** become substantially aligned along a direction normal to the surfaces of the substrates **102a** and **102b**.

[0063] The following describes the operation of the display **200**.

[0064] Referring to FIG. 11A, when no voltage is applied to the lower and upper electrodes **103** and **106**, the liquid crystal molecules **128** form a twisted structure as described above. In the T sub-pixel **206**, backlight **118** from the backlight module

**116** passes the lower linear polarizer **101a** and becomes linearly polarized light **132** having a polarization direction parallel to the transmission axis **100a** of the lower linear polarizer **101a**. As the linearly polarized light **132** passes the liquid crystal layer **202**, the polarization of the light **132** is rotated 90 degrees and becomes parallel to the transmission axis **100b**. The light **132** passes the upper polarizer **101b** and is seen by the viewer as a bright T sub-pixel **206**.

**[0065]** In the R sub-pixel **204**, incident ambient light **130** first passes the upper polarizer **101b** and becomes linearly polarized light **134** having a polarization direction parallel to the transmission axis **100b** of the upper polarizer **101b**. The polarization of the linearly polarized light **134** is rotated 90 degrees as the light **134** passes the liquid crystal layer **202** and becomes parallel to the lengthwise direction of the metal strips **120** on the wire grid polarizer **108**. The linearly polarized light **134** is reflected by the wire grid polarizer **108**. The reflected light initially has a polarization parallel to the lengthwise direction of the metal strips **120**. As the reflected light passes the liquid crystal layer **202**, the polarization of the reflected light is rotated 90 degrees and becomes parallel to the transmission axis of the upper polarizer **100b**. The reflected light passes the upper polarizer **100b** and is seen by the viewer as a bright R sub-pixel **204**. The display **200** is normally white because the pixels are in bright states when no pixel voltage is applied to the pixels.

**[0066]** Referring to FIG. 11B, when a pixel voltage  $V_{DATA} = V_{DARK}$  that corresponds to the dark state is applied to the electrodes **103** and **106**, the liquid crystal molecules **128** become substantially aligned along a direction normal to the surfaces of the substrates **102a** and **102b**. In the R sub-pixel **204**, the polarization of the linearly polarized light **134** does not change as the light **134** passes the liquid crystal layer **202**. Because the light **134** has a polarization perpendicular to the lengthwise direction of the metal strips **120** of the wire grid polarizer **108**, the light **134** passes the wire grid polarizer **108** and is absorbed by the lower polarizer **101a**. The viewer sees a dark R sub-pixel **204**. In the T sub-pixel **206**, the linearly polarized light **132** maintains its polarization as it passes the liquid crystal layer **202**, and is blocked by the upper polarizer **101b**. The viewer sees a dark T sub-pixel **206**.

**[0067]** Although the passivation layer **208** causes the percentage of the pixel voltage  $V_{DATA}$  applied to the R and T sub-pixels **202** and **206** to be different, the pixel voltage  $V_{DATA} = V_{DARK}$  is selected to be sufficiently high such that the liquid crystal molecules **128** in both the R and T sub-pixels are substantially vertical to the surfaces of the substrates **102a** and **102b**.

**[0068]** FIG. 12 shows a diagram of an equivalent circuit of the pixel **202** in FIG. 10. The portion of the liquid crystal layer **202** in the R sub-pixel **204** has an effective capacitance that is represented by a capacitor  $C_{LCR}$  (**210**). The portion of the liquid crystal layer **202** in the T sub-pixel **206** has an effective capacitance that is represented by a capacitor  $C_{LCT}$  (**212**). The passivation layer **208** has an effective capacitance represented by a capacitor  $C_D$  (**214**). The pixel voltage  $V_{DATA}$  is substantially fully applied to the liquid crystal layer **202** in the T sub-pixel **206**. By comparison, because  $C_D$  is connected in series with  $C_{LCR}$ , only a portion of the pixel voltage  $V_{DATA}$  is applied to the portion of the liquid crystal layer **202** in the R sub-pixel **204**.

**[0069]** FIG. 13 is a graph **220** showing a curve **222** that represents the voltage-transmittance characteristics of the T sub-pixel **206**. Also shown are curves **224**, **226**, **228**, and **230**

representing the voltage-reflectance characteristics of the R sub-pixel **204** when the passivation layer **208** has a thickness of 0, 320 nm, 480 nm, and 640 nm, respectively. The data points for the graph **220** were obtained using simulation. When the thickness  $d_2$  of the passivation layer **208** is equal to 480 nm, the curve **228** more closely matches the curve **222** (as compared to the curve **224** versus curve **222**), indicating that the voltage-transmittance characteristic of the T sub-pixel **206** more closely matches the voltage-reflectance characteristic of the R sub-pixel **204**. The R sub-pixel **204** and the T sub-pixel **206** will show similar gray scale (or color) for a given pixel voltage  $V_{DATA}$ .

**[0070]** In the simulations used to obtain the data for the graph **220**, the liquid crystal material used was ZLI-4792, available from Merck, Japan. The liquid crystal material has a parallel dielectric constant  $\epsilon_{11}=8.3$ , perpendicular dielectric constant  $\epsilon_{\perp}=3.1$ , and elastic constants  $K_{11}=13.2$  pN,  $K_{33}=6.5$  pN, and  $K_{33}=18.3$  pN. The liquid crystal material has an extraordinary refractive index  $n_e=1.5763$  and an ordinary refractive index  $n_o=1.4794$  at  $\lambda=589$  nm. The parameter  $d \cdot \Delta n$  of the liquid crystal layer **104** is set at 0.48  $\mu\text{m}$ . The passivation layer **105** can be made of dielectric materials (e.g.,  $\text{SiO}_2$ , which has a dielectric constant of 3.9) that are compatible with the thin film transistor fabrication process.

**[0071]** The thickness of the passivation layer **208** of FIG. 10 can be estimated using a voltage shifting method, similar to that for the passivation layer **105** of FIG. 1. FIG. 14 is a graph **240** that shows curves **222** and **224** representing the voltage-transmittance characteristics of the T sub-pixel **206** and the voltage-reflectance characteristics of the R sub-pixel **204**, respectively, when the passivation layer **208** has a thickness  $d_2=0$ . If the curve **224** is shifted towards the right of the figure, the curves **222** and **224** will more closely match each other. This means that for a given gray scale, the voltage level applied to the R sub-pixel **204** should be lower by a certain amount  $\Delta V$  than the voltage level applied to the T sub-pixel **206**. The thickness of the passivation layer **208** in FIG. 10 can be calculated using a method similar to that for calculating the thickness of the passivation layer **105** in FIG. 1.

**[0072]** FIG. 15 is a cross-sectional diagram of an example of a transmissive liquid crystal display **250** that is similar to the transmissive liquid crystal display **200** of FIG. 10, except that in the R sub-pixel **204** of the display **250**, the passivation layer **208** is positioned between the upper electrode **106** and the upper alignment layer **107b**. The lower electrode **103** is directly adjacent to the lower alignment layer **107a**. In the display **250**, similar to the display **200**, when a pixel voltage  $V_{DATA}$  is applied to the electrodes **103** and **106**, the percentage of the pixel voltage  $V_{DATA}$  applied to the liquid crystal layer **202** in the R sub-pixel **204** is lower than that in the T sub-pixel **206**.

**[0073]** The viewing angles of the displays **100** (FIG. 1), **190** (FIG. 9), **200** (FIG. 10), and **250** (FIG. 15) can be expanded by adding a compensation film between the upper substrate **102b** and the upper polarizer **101b**.

**[0074]** FIG. 16A is an iso-contrast plot **260** for an example of the display **100** (FIG. 1), in which a compensation film was not used. In this example, the display **100** included a liquid crystal material MLC-6608, available from Merck, Japan, in which the  $d \cdot \Delta n$  parameter of the liquid crystal material equals 0.36  $\mu\text{m}$ . The display **100** can achieve 10:1 contrast ratio over 40 degrees in most directions.

**[0075]** FIG. 16B is an iso-contrast plot **270** for an example of the display **100** (FIG. 1), in which a compensation film was

used to compensate light leakage from the liquid crystal phase retardation at off-axis angles. The compensation film used in this example is a negative C film with refractive indices  $n_o=1.5110$ , and  $n_e=1.5095$ , and the parameter  $d \cdot \Delta n$  of the negative C film is  $0.36 \mu\text{m}$ . The  $d \cdot \Delta n$  value for the liquid crystal layer and the C film are set to be equal so that the off-axis phase retardation from the liquid crystal layer cancels the off-axis phase retardation from the C film. With the addition of a compensation film, the display **100** has a 10:1 contrast ratio over 60 degrees in most directions.

**[0076]** FIG. **17** is a diagram of an example of the liquid crystal display **100**, in which the figure shows an array **12** of pixels **110** that are controlled by one or more gate drivers **16** and one or more data drivers **18**. Each pixel **110** includes one or more thin film transistors (TFT) **148**, a storage capacitor  $C_{st}$  **146**, and other components shown in FIG. **1**.

**[0077]** In a color display, each pixel **110** can have a red, green, or blue filter to show red, green, or blue color, respectively. A red pixel, a green pixel, and a blue pixel can together generate a color image pixel. By controlling the gray scale levels of the red, green, and blue pixels, each color image pixel can display a wide range of colors and gray scale levels.

**[0078]** Other implementations and applications are also within the scope of the following claims. For example, in FIG. **17**, the pixels **110** can be replaced by other types of pixels, such as those shown in FIGS. **9**, **10**, and **15**. Additional passivation layers and alignment layers can be used in the displays described above. The materials used for the components of the displays, such as the liquid crystal layer, the polarization films, and the compensation films, can use materials and have parameters different from those described above. The retardation values  $d \cdot \Delta n$  of the films can be different from those described above. Compensation films different from those described above can be used. In some examples, a negative C film or a positive **0** film can be used as a compensation film. Other compensation films are described in "Analytical solutions for uniaxial-film-compensated wide-view liquid crystal displays" by X. Zhu et al, Journal of Display Technology, vol. 2, pages 2-20, 2006, herein incorporated by reference. When the display is operating in the transmissive mode in which the backlight module is turned on, some ambient light may be reflected by the transflector, so the display can operate in both the transmissive and reflective modes at the same time.

**[0079]** In the description above, the terms "upper" and "lower" are used to describe relative positions of components as shown in the figures. The display can have various orientations, so for example, an upper film may be positioned below a lower film depending on the orientation of the display. The orientations of the liquid crystal molecules described above refer to the directions of directors of the liquid crystal molecules. The molecules do not necessarily all point to the same direction all the time. The molecules may tend to point more in one direction (represented by the director) over time than other directions. For example, the phrase "the liquid crystal molecules are substantially aligned along a direction normal to the substrates" means that the average direction of the directors of the liquid crystal molecules is generally aligned along the normal direction, but the individual molecules may point to different directions.

What is claimed is:

**1.** A display comprising:

- a plurality of pixel circuits each comprising
  - a first electrode;
  - a second electrode;

- a reflective region to reflect ambient light, the reflective region comprising a first portion of a liquid crystal layer between the first and second electrodes, and a polarization dependent reflector that transmits light having a first polarization and reflects light having a second polarization;

- a transmissive region to transmit backlight, the transmissive region comprising a second portion of the liquid crystal layer between the first and second electrodes;

- a dielectric layer between the first and second electrodes in one of the reflective region and the transmissive region, the dielectric layer configured such that when a pixel voltage is applied to the first and second electrodes, the percentage of the pixel voltage applied across the first portion of the liquid crystal layer is different from the percentage of the pixel voltage applied across the second portion of the liquid crystal layer; and

- a backlight module to generate the backlight.

**2.** The display of claim **1** wherein the polarization dependent reflector comprises a wire grid polarizer.

**3.** The display of claim **1** wherein the dielectric layer is in the reflective region and configured such that when the pixel voltage is applied to the first and second electrodes, the percentage of the pixel voltage applied across the first portion of the liquid crystal layer is lower than the percentage of the pixel voltage applied across the second portion of the liquid crystal layer.

**4.** The display of claim **3** wherein the liquid crystal layer is between two substrates, and the liquid crystal layer comprises liquid crystal molecules that are substantially aligned along a direction parallel to the surfaces of the substrates when no voltage is applied to the first and second electrodes.

**5.** The display of claim **1** wherein the dielectric layer is in the transmissive region and configured such that when the pixel voltage is applied to the first and second electrodes, the percentage of the pixel voltage applied across the first portion of the liquid crystal layer is higher than the percentage of the pixel voltage applied across the second portion of the liquid crystal layer.

**6.** The display of claim **5** wherein the liquid crystal layer is between two substrates, and the liquid crystal layer comprises liquid crystal molecules that are substantially aligned along a direction normal to the substrates when no voltage is applied to the first and second electrodes.

**7.** The display of claim **1** wherein the dielectric layer has a dielectric constant and a thickness that are selected to reduce a difference between a transmittance of the transmissive region and a reflectance of the reflective region for a given pixel voltage applied to the first and second electrodes.

**8.** The display of claim **1** wherein the dielectric layer functions as a capacitor that is connected in series with the liquid crystal layer between the first and second electrodes.

**9.** The display of claim **1** wherein the dielectric layer comprises at least one of silicon oxide and silicon nitride.

**10.** The display of claim **1** wherein at least one of the first electrode and the second electrode comprises at least one of indium tin oxide, indium zinc oxide, and gallium zinc oxide.

**11.** The display of claim **1**, further comprising a first linear polarizer and a second linear polarizer that both extend over the transmissive and reflective regions, the first and second linear polarizers being at different sides of the liquid crystal layer.

**12.** The display of claim **11** wherein the first linear polarizer is closer to a viewer than the second linear polarizer, and the polarization dependent reflector has a reflective axis that is perpendicular to a transmission axis of the first linear polarizer.

**13.** The display of claim **1** wherein the liquid crystal layer is between two substrates, and the liquid crystal layer comprises liquid crystal molecules that are substantially aligned along a direction normal to the substrates when no voltage is applied to the first and second electrodes.

**14.** The display of claim **1** wherein the liquid crystal layer comprises a negative dielectric anisotropic liquid crystal material.

**15.** The display of claim **1** wherein the liquid crystal layer comprises a positive dielectric anisotropic liquid crystal material.

**16.** A display comprising:  
a first substrate;  
a second substrate;

pixel circuits between the first and second substrates, each pixel circuit having a transmissive portion and a reflective portion, each pixel circuit comprising a first electrode, a second electrode, a liquid crystal cell, a polarization dependent reflector located at the reflective portion, and a shield capacitor located at one of the reflective and transmissive portions and positioned in series with the liquid crystal cell.

**17.** The display of claim **16** wherein the shield capacitor is configured to cause a gray scale gamma curve of the transmissive region to more closely match a gray scale gamma curve of the reflective region, as compared to the pixel circuit without the shield capacitor.

**18.** The display of claim **16** wherein the pixel circuits are in dark states when no pixel voltage is applied to the pixel circuits.

**19.** The display of claim **16** wherein the pixel circuits are in bright states when no pixel voltage is applied to the pixel circuits.

**20.** A transmissive display comprising:  
a first linear polarizer having a first transmission axis;  
a second linear polarizer having a second transmission axis, the first linear polarizer located closer to a front side of the display than the second linear polarizer;  
pixel circuits each comprising:

a liquid crystal layer between the first and second linear polarizers, the liquid crystal layer having a first portion and a second portion, the first portion corresponding to a reflective portion of the pixel circuit, the second portion corresponding to a transmissive portion of the pixel circuit;

a storage capacitor to store an electric charge corresponding to a pixel voltage;

a polarization dependent reflector that is associated with the first portion of the liquid crystal layer, the polarization dependent reflector to reflect a first component of external light and transmit a second component of the external light, the first component having a first polarization substantially perpendicular to the first transmission axis and the second component having a second polarization substantially parallel to the first transmission axis; and

means for applying a first percentage of the pixel voltage to the first portion of the liquid crystal layer and a second percentage of the pixel voltage to the second

portion of the liquid crystal layer, the first percentage being different from the second percentage.

**21.** The display of claim **20** wherein the means for applying the first and second percentages of the pixel voltage is configured to cause the transmissive portion to have a transmittance-voltage characteristic that more closely matches a reflectance-voltage characteristic of the reflective portion, as compared to a pixel circuit that applies the same percentage of the pixel voltage to the first and second portions of the liquid crystal layer.

**22.** A method comprising:

reflecting external light having a first polarization after the external light passes a liquid crystal layer in a reflective region of a pixel of a display, the reflected light being directed toward a viewer of the display;

transmitting external light having a second polarization after the external light passes the liquid crystal layer in the reflective region, the transmitted light being directed away from the viewer;

transmitting backlight through the liquid crystal layer in a transmissive region of the pixel, the transmitted light being directed toward the viewer;

applying a first percentage of a pixel voltage to the liquid crystal layer in the reflective region; and

applying a second percentage of the pixel voltage to the liquid crystal layer in the transmissive region, the second percentage being different from the first percentage.

**23.** The method of claim **22** wherein the first and second percentages are configured to cause the transmittance of the transmissive region to more closely match the reflectance of the reflective region for a given pixel voltage, as compared to applying a same percentage of the pixel voltage to the reflective and transmissive regions.

**24.** The method of claim **22**, further comprising showing a dark state at the pixel when the pixel voltage is below a threshold.

**25.** The method of claim **22**, further comprising showing a bright state at the pixel when the pixel voltage is below a threshold.

**26.** The method of claim **22**, further comprises aligning liquid crystal molecules of the liquid crystal layer along directions substantially normal to surfaces of two substrates when no voltage is applied to the first and second electrodes, the liquid crystal layer being positioned between the two substrates.

**27.** The method of claim **22**, further comprising aligning liquid crystal molecules of the liquid crystal layer along directions substantially parallel to surfaces of two substrates when no voltage is applied to the first and second electrodes, the liquid crystal layer being positioned between the two substrates.

**28.** A method comprising:

forming a polarization dependent reflector in a first region of first substrate, the first region corresponding to a reflective region of a pixel of a display;

forming a first electrode on the first substrate;

forming a second electrode on a second substrate;

forming a dielectric layer on a portion of the first electrode or a portion of the second electrode, the dielectric layer corresponding to either the reflective region of the pixel or a transmissive region of the pixel; and

providing a liquid crystal layer between the first and second substrates, the dielectric layer being positioned in series with the liquid crystal layer between the first and second electrodes.

**29.** The method of claim **28**, further comprising providing alignment layers on the first and second substrates to cause the liquid crystal molecules of the liquid crystal layer to substantially align along a direction normal to the surfaces of the substrates when no voltage is applied to the first and second electrodes.

**30.** The method of claim **28**, further comprising providing alignment layers on the first and second substrates to cause

the liquid crystal molecules of the liquid crystal layer to substantially align along a direction parallel to the surfaces of the substrates when no voltage is applied to the first and second electrodes.

**31.** The method of claim **28**, further comprising providing a first linear polarizer at a side of the first substrate facing away from the liquid crystal layer, and providing a second linear polarizer at a side of the second substrate facing away from the liquid crystal layer, the first linear polarizer having a transmission axis that is non-parallel to a transmission axis of the second linear polarizer.

\* \* \* \* \*

专利名称(译)	透反液晶显示器		
公开(公告)号	<a href="#">US20080204636A1</a>	公开(公告)日	2008-08-28
申请号	US11/678691	申请日	2007-02-26
[标]申请(专利权)人(译)	群创光电股份有限公司 佛罗里达大学研究基金会有限公司		
申请(专利权)人(译)	奇美电子股份有限公司 佛罗里达州研究基金会, Inc.的大学.		
当前申请(专利权)人(译)	FISH & RICHARDSON P.C. 佛罗里达中部研究基金会, Inc.的大学.		
[标]发明人	GE ZHIBING ZHU XINYU WU THOMAS XINZHANG WU SHIN TSON LI WANG YANG WEI CHUNG KUANG		
发明人	GE, ZHIBING ZHU, XINYU WU, THOMAS XINZHANG WU, SHIN-TSON LI, WANG-YANG WEI, CHUNG-KUANG		
IPC分类号	G02F1/1335		
CPC分类号	G02F1/133345 G02F1/133536 G02F2202/42 G02F2001/133538 G02F2001/133548 G02F1/133555		
外部链接	<a href="#">Espacenet</a> <a href="#">USPTO</a>		

摘要(译)

显示器包括多个像素电路，每个像素电路包括第一电极，第二电极，反射区域和透射区域。反射区域反射环境光并包括液晶层的第一部分和偏振相关反射器。透射区域透射背光并包括液晶层的第二部分。介电层位于反射区域和透射区域之一中的第一和第二电极之间，介电层配置成使得当像素电压施加到第一和第二电极时，施加在第一和第二电极上的像素电压的百分比液晶层的一部分与施加在液晶层的第二部分上的像素电压的百分比不同。显示器包括用于产生背光的背光模块。

