



Fig.1  
Related Art

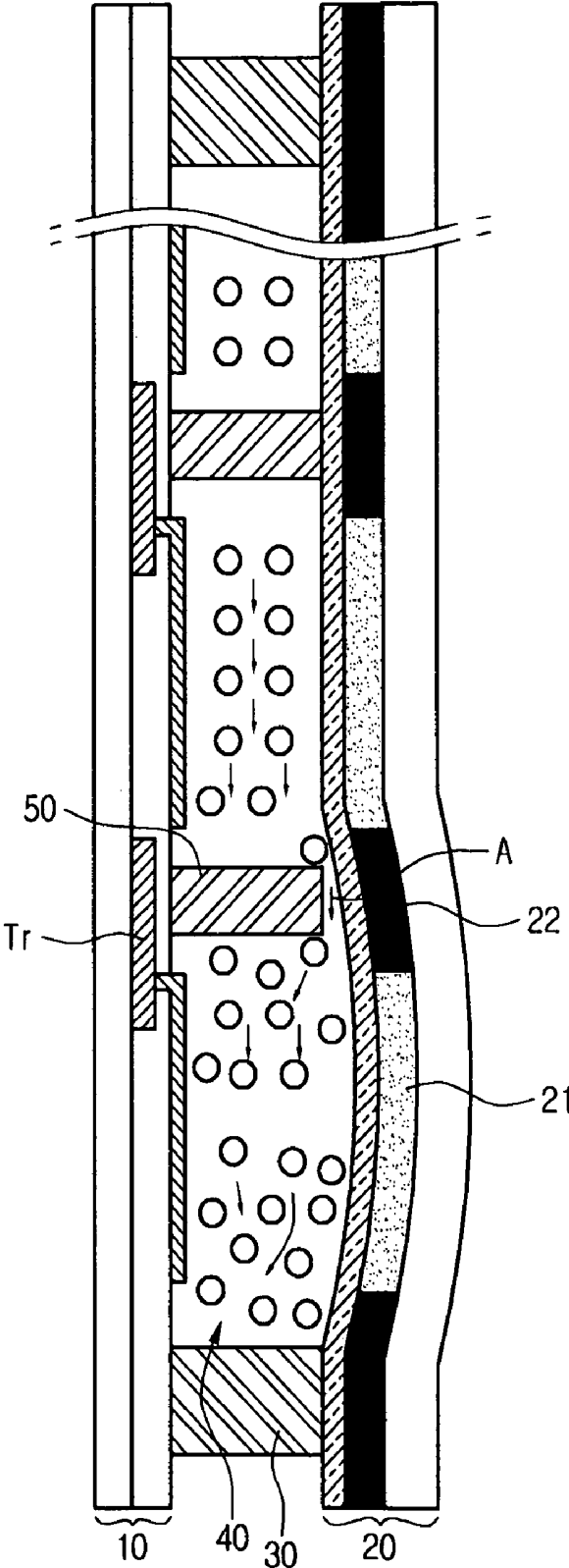

Fig.2

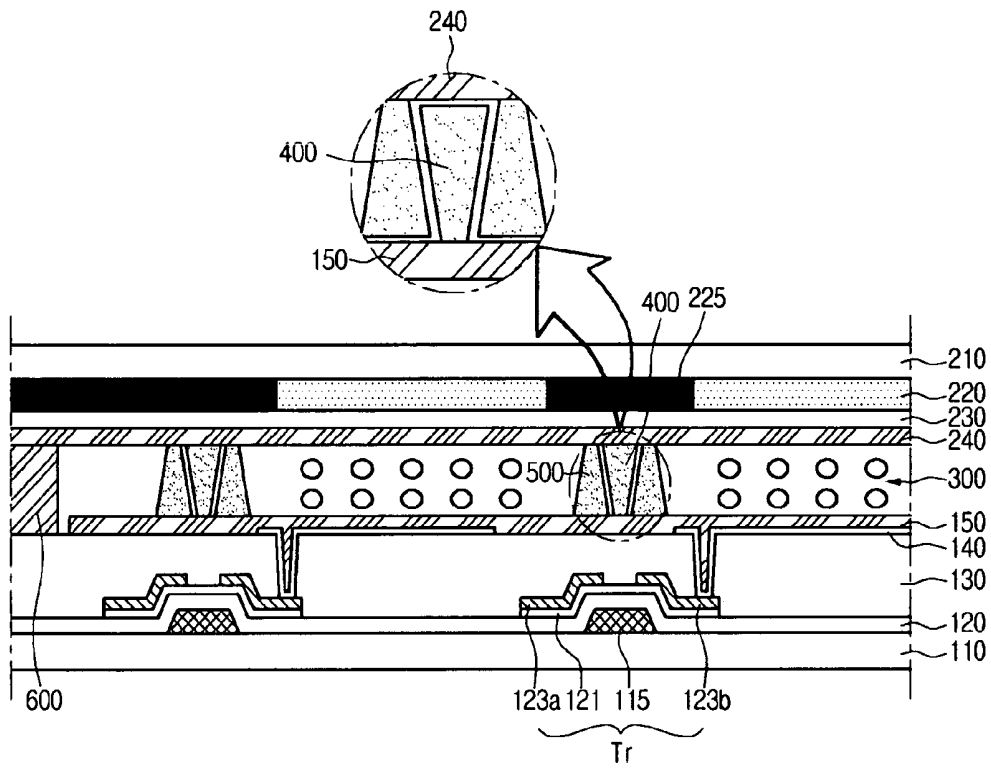

Fig.3A

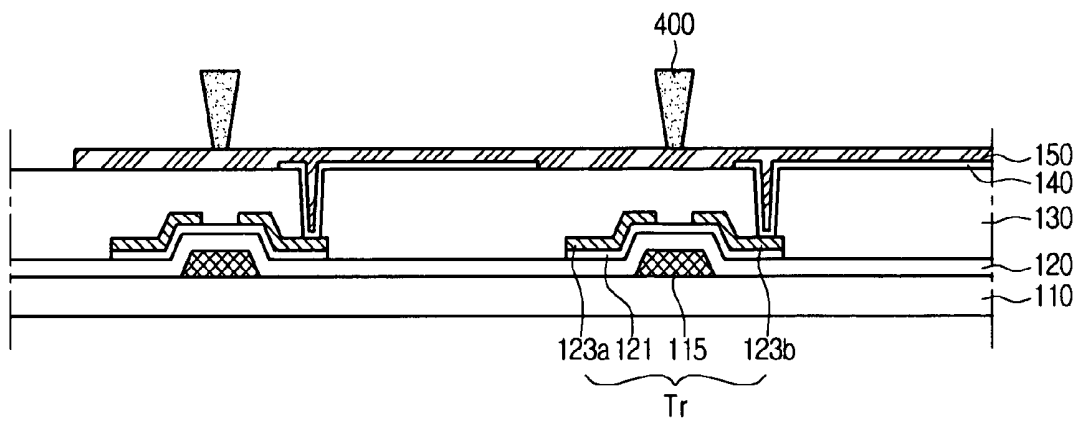

Fig.3B

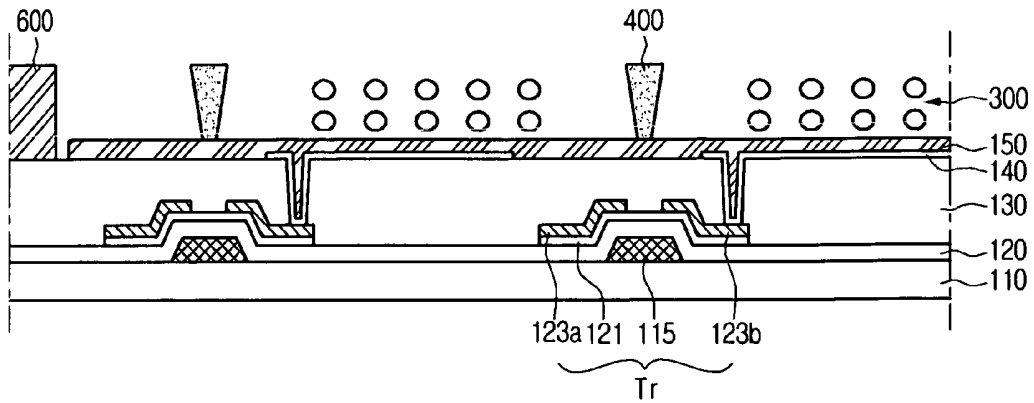

Fig.3C

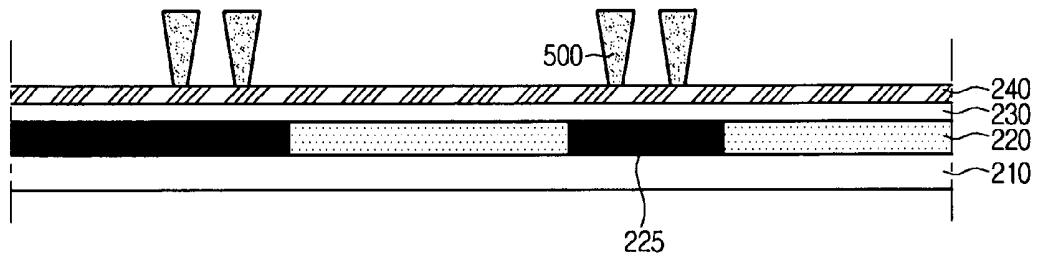
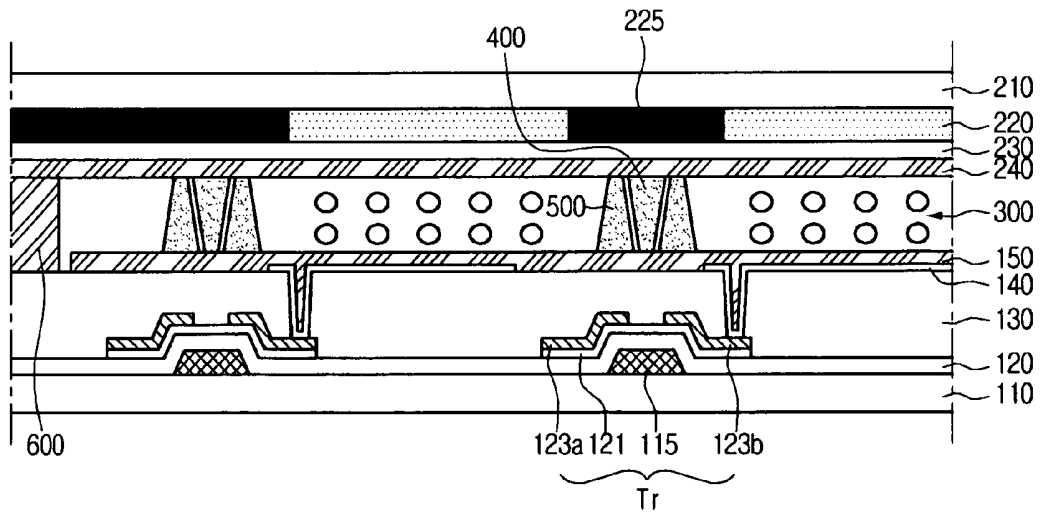

Fig.3D



## LIQUID CRYSTAL DISPLAY DEVICE AND METHOD OF FABRICATING THE SAME

[0001] The present invention claims the benefit of Korean Patent Application No. 090417/2005 filed in Korea on Sep. 28, 2005, which is hereby incorporated by reference in its entirety.

### BACKGROUND OF THE INVENTION

[0002] 1. Field of the Invention

[0003] The present invention relates to a display device, and more particularly, to a liquid crystal display device and a method of fabricating the same.

[0004] 2. Description of the Related Art

[0005] The liquid crystal display (LCD) device has been most favored recently as an efficient and value-added next generation display device, due to its low power consumption and its portability. In general, the LCD includes a lower substrate and an upper substrate arranged facing the lower substrate with a liquid crystal layer interposed between the lower substrate and the upper substrate. The lower substrate has a thin film transistor and a pixel electrode formed thereon. The upper substrate has a black matrix layer, a color filter layer and a common electrode formed thereon. The lower and upper substrates maintain a constant cell gap using a spacer. In such an LCD, an electric field is formed between the lower and upper substrates by a pixel electrode and a common electrode to align liquid crystal molecules, and light transmittance is adjusted through the alignment of the liquid crystal molecules to thereby display images. The picture quality of an LCD device is influenced by the integrity of the liquid crystal layer interposed between the two substrates. For instance, if the liquid crystal material is over-filled or expands due to high temperature, gravity failure may occur.

[0006] FIG. 1 is a cross-sectional view of the related art LCD showing a gravity failure. As shown in FIG. 1, the related art LCD includes a lower substrate 10, an upper substrate 20, and a liquid crystal layer 40 interposed between the lower substrate 10 and the upper substrate 20. The lower substrate 10 has a thin film transistor (Tr) formed thereon. The upper substrate 20 has a color filter layer 21 and a black matrix layer 22 formed thereon. The lower substrate 10 and the upper substrate 20 are attached by a seal pattern 30. The lower and upper substrates 10 and 20 maintain a constant cell gap using pattern spacers 50. The liquid crystal layer 40 is formed by injecting a liquid crystal material into an inner space between the lower and upper substrates 10 and 20 defined by the pattern spacers 50.

[0007] A proper amount of the liquid crystal material should be injected into the inner space. However, it is difficult to control the injection amount of the liquid crystal material. Sometimes, the liquid crystal material may over-fill the inner space, which can result in a gravity failure. Over-filling can cause other problems. For example, when the temperature of the liquid crystal material is increased due to an external environment, the volume of the liquid crystal expands to become larger than the inner space. If such an expansion occurs, the pattern spacers 50 are detached from one of the two substrates such that a liquid crystal path 'A' may be generated. Through the liquid crystal path 'A', the liquid crystal is collected downward, so that the

cell gap becomes non-uniform. The non-uniform cell gap deteriorates the quality of the LCD and may cause a touch failure. Gravity failure and the touch brightness failure become exacerbated as the screen size of the LCD increases.

### SUMMARY OF THE INVENTION

[0008] Accordingly, the present invention is directed to a liquid crystal display and a method of fabricating the same that substantially obviate one or more problems due to limitations and disadvantages of the related art.

[0009] An object of the present invention is to provide a liquid crystal display and a method of fabricating the same for preventing touch brightness failure in an LCD panel.

[0010] Another object of the present invention is to provide a liquid crystal display and a method of fabricating the same for preventing gravity failure in an LCD panel.

[0011] An object of the present invention is to provide a liquid crystal display and a method of fabricating the same to maintain the cell gap in an LCD panel.

[0012] Additional advantages, objects, and features of the invention will be set forth in part in the description which follows and in part will become apparent to those having ordinary skill in the art upon examination of the following or may be learned from practice of the invention. The objectives and other advantages of the invention can be realized and attained by the structure particularly pointed out in the written description and claims hereof as well as the appended drawings.

[0013] To achieve these objects and other advantages and in accordance with the purpose of the invention, as embodied and broadly described herein, there is provided a liquid crystal display device including: a first substrate having a plurality of gate lines and a plurality of data lines crossing each other; a second substrate facing the first substrate; a first pattern spacer having an inverse tapered shape on an inner surface of the first substrate; a second pattern spacer having an inverse tapered shape on an inner surface of the second substrate; a seal pattern on a peripheral edge of the first and second substrates; and a liquid crystal layer between the first and second substrates, wherein the first and second pattern spacers have a tapered shape.

[0014] In another aspect, a liquid crystal display device includes: a first substrate having a plurality of gate lines and a plurality of data lines crossing each other; a second substrate facing the first substrate; a first pattern spacer having an inverse tapered shape on an inner surface of the first substrate; a second pattern spacer having an inverse tapered shape on an inner surface of the second substrate; a seal pattern on a peripheral edge of the first and second substrates; and a liquid crystal layer between the first and second substrates, wherein the first and second pattern spacers are interleaved.

[0015] In another aspect, there is provided a method of fabricating a liquid crystal display device that includes providing a first substrate having a thin film transistor formed on a unit pixel region defined by a plurality of gate lines crossing a plurality of data lines, forming a passivation layer having a contact hole exposing a drain electrode of the thin film transistor, forming a pixel electrode connected with the drain electrode through the contact hole, forming a

photoresist film on the passivation layer, and exposing and developing the photoresist film to form a first pattern spacer having a tapered shape.

[0016] It is to be understood that both the foregoing general description and the following detailed description of the present invention are exemplary and explanatory and are intended to provide further explanation of the invention as claimed.

#### BRIEF DESCRIPTION OF THE DRAWINGS

[0017] The accompanying drawings, which are included to provide a further understanding of the invention and are incorporated in and constitute a part of this application, illustrate embodiment(s) of the invention and together with the description serve to explain the principle of the invention.

[0018] FIG. 1 is a cross-sectional view of a related art LCD showing a gravity failure.

[0019] FIG. 2 is a cross-sectional view of an LCD according to an embodiment of the present invention.

[0020] FIGS. 3A through 3D are cross-sectional views illustrating a method of fabricating an LCD according to an embodiment of the present invention.

#### DETAILED DESCRIPTION OF THE PREFERRED EMBODIMENTS

[0021] Reference will now be made in detail to the preferred embodiments of the present invention, examples of which are illustrated in the accompanying drawings. The invention can, however, be embodied in many different forms and should not be construed as being limited to the embodiments set forth herein; rather, these embodiments are provided so that this disclosure will be thorough and complete, and will fully convey the concept of the invention to those skilled in the art. In the drawings, the thicknesses of layers and regions are exaggerated for clarity. Like reference numerals in the drawings denote like elements.

[0022] FIG. 2 is a cross-sectional view of an LCD according to an embodiment of the present invention. As shown in FIG. 2, the LCD includes a first substrate 110, a second substrate 210, and a liquid crystal layer interposed between the first and second substrates 110 and 210. The first substrate 110 has thin film transistors (Tr) and a first pattern spacer 400 formed thereon. The second substrate 210 has a color filter layer 220 and a second pattern spacer 500 formed thereon. The first and second substrates 110 and 210 are attached to each other by a seal pattern 600 formed on a peripheral edge of the two substrates for maintaining a constant cell gap.

[0023] The first pattern spacer 400 and the second pattern spacer 500 have inverse tapered shapes that complement each other. More particularly, an inverse tapered shape has a bottom surface area contacting the substrate that is smaller than an opposite top surface area. The first pattern spacer 400 and the second pattern spacer 500 are disposed to be interlocked with each other. In other words, the second pattern spacer 500 can be inserted between the first pattern spacers 400. In an alternative, the first pattern spacer 400 can be inserted between the second pattern spacers 500. Such an interlocked structure prevents a liquid crystal path from

forming between regions, and the first and second substrates 110 and 210 from separating from each other.

[0024] Referring to FIG. 2, a plurality of gate lines (not shown) and a plurality of data lines (not shown) are arranged crossing each other on the first substrate 110, and a thin film transistor (Tr) is disposed adjacent to a crossing of the gate line and the data line within each unit pixel. Over the entire surface of the first substrate 110 including the thin film transistor (Tr), a passivation layer 130 is disposed. The passivation layer 130 is an inorganic insulation material, such as silicon nitride or silicon oxide. Herein, the passivation layer 130 is provided with a contact hole exposing a drain electrode of the thin film transistor (Tr).

[0025] A pixel electrode 140 is positioned on the passivation layer 130 and is connected with the drain electrode through the contact hole. A first alignment film 240 is positioned on the pixel electrode 140. The first alignment film 240 functions to align the liquid crystal molecules of the liquid crystal layer 300 in a selected direction. The first pattern spacer 400 can be positioned on the first alignment layer 240 corresponding to a non-transmission region of the first substrate 110, such as a region where the thin film transistor, a capacitor or a plurality of interconnection lines are formed. This is because the first pattern spacer 400 affects the light transmittance.

[0026] The first pattern spacer 400 can be made of an organic insulation material, such as a negative photoresist material. The organic insulation material can be a Novalac photoresist resin. The first pattern spacer 400 can have an inverse tapered shape. Unlike in the drawing, the first pattern spacer 400 can be formed as a plurality of spacers. Thereafter, the first pattern spacers 500 can be inserted between the second pattern spacers 500 to enhance an adhesive force between the first substrate 110 and the second substrate 210.

[0027] Meanwhile, the second substrate 210 is disposed facing the first substrate 110. The second substrate 210 includes a black matrix layer 225 formed on a region corresponding to a non-transmission region where the thin film transistor (Tr) is formed, and a color filter layer 220 formed on a region corresponding to a transmission region to express colors. A transparent upper electrode 230 serving as a common electrode is formed on the black matrix layer 225 and the color filter layer 220, and a second alignment layer 240 is positioned below the upper transparent electrode 230.

[0028] The second pattern spacer 500 is positioned on a region corresponding to the non-transmission region on the second alignment layer 240, i.e., on a region where the black matrix layer 225 is formed. The second pattern spacer 500 can have an inverse tapered shape. Unlike in the drawing, the second pattern spacer 500 is formed in plurality. This is because the first pattern spacers 400 are interlocked between the second pattern spacers 500 such that the second pattern spacers 500 are not separated from the first substrate 110. The second pattern spacer 500 can be made of an organic insulation material, such as a negative photoresist material. Alternatively, the second pattern spacer 500 can be formed of a Novalac photoresist resin.

[0029] The liquid crystal layer 300 interposed between the first substrate 110 and the second substrate 210 can be a liquid crystal material, such as twisted nematic (TN), super

twisted nematic (STN), electrically controlled birefringence (ECB), optically compensated birefringence (OCB), hybrid aligned nematic (HAN) and vertical alignment (VA) modes.

[0030] FIGS. 3A through 3D are cross-sectional views illustrating a method of fabricating an LCD according to an embodiment of the present invention. Referring to FIG. 3A, a first substrate **110** is first provided. The first substrate **110** can be a plastic substrate or a glass substrate. A plurality of gate lines and a plurality of data lines perpendicularly cross each other to define a pixel region on the first substrate **110**, and thin film transistors (Tr) are also formed adjacent to the crossings of the pluralities of gate lines and data lines.

[0031] Each of the thin film transistors (Tr) is formed by the following process operations. First, a first conductive layer is formed on the first substrate and is then patterned to form a gate electrode **115**. The first conductive layer can be made of a low resistance conductive material, such as, Al, Mo, Cu or an alloy thereof. Thereafter, a gate insulation layer **120** is formed on the entire surface of the first substrate **110**, including the gate electrode **115**. The gate insulation layer **120** can be silicon nitride or silicon oxide formed by chemical vapor deposition (CVD). A silicon layer and a doped amorphous silicon layer are sequentially deposited and are then patterned to form an active layer **121**. Thereafter, a second conductive layer is deposited on the first substrate **110**, including the active layer **121**, and is then patterned to form a source/drain electrode **123a/123b**. The second conductive layer can be formed of Mo, Cr, Al or an alloy thereof.

[0032] Through the above process operations, a thin film transistor (Tr) having the gate electrode **115**, the active layer **121** and the source/drain electrode **123a/123b** is formed on the first substrate **110**. Thereafter, a passivation layer **130** is formed on the entire surface of the first substrate **110**, including the thin film transistor (Tr). The passivation layer **130** is an inorganic insulation layer, such as silicon nitride or silicon oxide.

[0033] A contact hole exposing the drain electrode **123b** is formed in the passivation layer **130**. Thereafter, a transparent conductive layer is formed on the passivation layer **130** and is then patterned to form a pixel electrode **140**. The pixel electrode **140** can be made of indium tin oxide (ITO), indium zinc oxide (IZO) or indium tin zinc oxide (ITZO). Although not shown in the drawings, a first alignment layer is then formed on the first substrate **110**, including the pixel electrode **140**. The alignment layer **150** can be formed by coating one selected from the group consisting of polyamide, polyimide compound, a polyvinyl alcohol and a polyamic acid. Then, a surface of the coated film is rubbed. Alternatively, the alignment layer **150** can be formed by coating one of polyvinyl cinnamate, polysiloxane cinnamate and cellulose cinnamate compounds, which is then subjected to photo-rubbing.

[0034] A negative photoresist material is coated on the first alignment layer **150** to form a photoresist film. The photoresist film is exposed to light and developed to form a first pattern spacer **400**. The negative photoresist material can be a Novalac photoresist resin. The first pattern spacer **400** can have an inverse tapered shape due to the exposure development characteristics of the photoresist material. The first pattern spacer **400** is formed on a region of the first substrate **110** where one of the thin film transistor Tr, a capacitor and the pluralities of gate and data lines is formed.

[0035] Referring to FIG. 3B, a seal pattern **600** is formed on a peripheral edge of the first substrate **110**, and a liquid crystal is dropped on the first substrate **110** to form a liquid crystal layer **300**. The seal pattern **600** can be made of an ultraviolet(UV)-curing sealant rather than a thermal curing sealant. A thermal-curing sealant may contaminate the liquid crystal material.

[0036] Referring to FIG. 3C, a second substrate **210** can be a plastic substrate or a glass substrate. Next a black matrix layer **225** is formed. The black matrix layer **225** shields light from being leaked in the region where a plurality of interconnection lines and thin film transistors are formed. Thereafter, a color filter layer **230** having red (R), green (G) and blue (B) color filter elements is formed thereon. Thereafter, a transparent conductive layer is deposited on the second substrate **210**, including the color filter layer **230** and the black matrix layer **225**, and is then patterned to form an upper electrode **230**. At this time, as aforementioned, a second alignment layer **240** can be further formed on the upper electrode **240**.

[0037] A negative photoresist material is coated on the second alignment layer **240**, and is exposed to light and developed to form a second pattern spacer **500**. The second pattern spacer **500** is preferably formed to have a plurality of inverse tapered shape spacers. Because of the availability of space on the black matrix layer **225**, or alternatively, above the black matrix layer **225** on the alignment layer **240**, more second pattern spacers **500** are formed on the second substrate **210** than first pattern spacers **400** formed on the first substrate **110**. As aforementioned, to form the second pattern spacer **500** in the inverse tapered shape, the second pattern spacer **500** is formed of a negative photoresist material. For example, the second pattern spacer **500** can be a Novalac photoresist resin.

[0038] Referring to FIG. 3D, the first substrate **110** and the second substrate **210** are positioned such that a vacuum state can occur between the first and second substrates **110** and **210**. The first pattern spacer **400** and the second pattern spacer **500** are interlocked with each other by the pressure difference created by the vacuum. In other words, the second pattern spacer **500** can be inserted between the first pattern spacers **400** or the first pattern spacer can be inserted between the second pattern spacers **500**. Then, UV is irradiated onto the seal pattern **600** such that the first and second substrates **110** and **210** are attached. The liquid crystal layer **300** is then formed by an injection method using a subsequent vacuum. The LCD panel is sealed, thereby completing an LCD panel.

[0039] The above embodiment describes interlocking the first pattern spacer **400** and the second pattern spacer **500** with a vacuum, the first pattern spacer **400** and the second pattern spacer **500** can alternatively be interlocked by sliding the patterns into each other. For example, one of the substrates is held in a fixed position while the other substrate is applied to the one substrate in a slightly offset manner and then the other substrate is slid so as to have the first and second pattern spacers interlock. Prior to sliding and interlocking the first and second pattern spacers, liquid crystal can be dropped on the one substrate to form the liquid crystal layer **300**, which has a seal about the periphery of the substrate. Alternatively, the liquid crystal layer **300** is formed by a vacuum injection method after the substrates

are attached by the interlocking first and second pattern spacers. Then, the LCD panel is sealed, thereby completing an LCD panel.

[0040] The first pattern spacer 400 formed on the first substrate 110 is interlocked with the second pattern spacer 500 formed on the second pattern spacer 210 or vice versa such that the first and second substrates 110 and 210 are not easily separated. Thus, the interlocking first and second pattern spacers prevent bulging of the LCD panel. Further, the interlocking first and second pattern spacers prevent a liquid crystal material path between regions of the LCD panel. Consequently, a good quality LCD can be fabricated.

[0041] It will be apparent to those skilled in the art that various modifications and variations can be made in the present invention. Thus, it is intended that the present invention covers the modifications and variations of this invention provided they come within the scope of the appended claims and their equivalents.

What is claimed is:

1. A liquid crystal display device comprising:

a first substrate having a plurality of gate lines and a plurality of data lines crossing each other;

a second substrate facing the first substrate;

a first pattern spacer having an inverse tapered shape on an inner surface of the first substrate;

a second pattern spacer having an inverse tapered shape on an inner surface of the second substrate;

a seal pattern on a peripheral edge of the first and second substrates; and

a liquid crystal layer interposed between the first and second substrates.

2. The liquid crystal display device according to claim 1, wherein the first and second pattern spacers are made of an organic insulation material.

3. The liquid crystal display device according to claim 1, wherein the first and second pattern spacers are made of a negative photoresist material.

4. The liquid crystal display device according to claim 1, wherein the first and second pattern spacers are made of Novalac photoresist resin.

5. The liquid crystal display device according to claim 1, wherein the first and second pattern spacers are interlocked with each other.

6. The liquid crystal display device according to claim 1, wherein the first pattern spacer is formed on a region of the first substrate where one of the thin film transistor, a capacitor, and the pluralities of gate and data lines are formed.

7. The liquid crystal display device according to claim 1, wherein the second pattern spacer is formed on a region of the second substrate where a black matrix layer of the second substrate is formed.

8. The liquid crystal display device according to claim 7, wherein more second pattern spacers are formed on the second substrate than first pattern spacers formed on the first substrate.

9. A liquid crystal display device comprising:

a first substrate having a plurality of gate lines and a plurality of data lines crossing each other;

a second substrate facing the first substrate;

a first pattern spacer having an inverse tapered shape on an inner surface of the first substrate;

a second pattern spacer having an inverse tapered shape on an inner surface of the second substrate;

a seal pattern a peripheral edge of the first and second substrates; and

a liquid crystal layer between the first and second substrates, wherein the first and second pattern spacers are interleaved.

10. The liquid crystal display device according to claim 9, wherein the first and second pattern spacers are made of an organic insulation material.

11. The liquid crystal display device according to claim 9, wherein the first and second pattern spacers are made of a negative photoresist material.

12. The liquid crystal display device according to claim 9, wherein the first and second pattern spacers are made of a Novalac photoresist resin.

13. The liquid crystal display device according to claim 9, wherein the first and second pattern spacers are interlocked with each other.

14. The liquid crystal display device according to claim 9, wherein the first pattern spacer is formed on a region of the first substrate where one of the thin film transistor, a capacitor, and the pluralities of gate and data lines are formed.

15. The liquid crystal display device according to claim 9, wherein the second pattern spacer is formed on a region of the second substrate where a black matrix layer of the second substrate is formed.

16. The liquid crystal display device according to claim 14, wherein more second pattern spacers are formed on the second substrate than first pattern spacers formed on the first substrate.

17. A method of fabricating a liquid crystal display device, the method comprising:

providing a first substrate having a thin film transistor formed on a unit pixel region defined by a plurality of gate lines crossing a plurality of data lines;

exposing and developing a first photoresist film to form a first pattern spacer having an inverse tapered shape on the first substrate;

providing a second substrate having a black matrix layer and a color filter layer;

exposing and developing a second photoresist film to form a second pattern spacer having an inverse tapered shape on the second substrate; and

attaching the first and second substrates.

18. The method according to claim 17, further comprising:

positioning the second substrate above the first substrate; and

interlocking the first and second pattern spacers using a vacuum between the first and second substrates.

19. The method according to claim 17, further comprising:

positioning the second substrate above and slightly offset from the first substrate; and

interlocking the first and second pattern spacers by sliding the second substrate.

20. The method according to claim 17, wherein the photoresist film is made of a negative photoresist material.

21. The method according to claim 17, further comprising:

forming a seal pattern on a peripheral edge of the first substrate;

dropping a liquid crystal material on the first substrate to form a liquid crystal layer;

positioning the second substrate above and slightly offset from the first substrate; and

interlocking the first and second pattern spacers by sliding one of the first and second substrates.

22. The method according to claim 17, further comprising:

forming a seal pattern on a peripheral edge of the first substrate;

positioning the second substrate above and slightly offset from the first substrate;

interlocking the first and second pattern spacers by sliding one of the first and second substrates; and

injecting liquid crystal to form a liquid crystal layer.

23. The method according to claim 17, further comprising:

forming a seal pattern on a peripheral edge of the first substrate;

providing the second substrate above the first substrate, the second substrate including a second pattern spacer formed thereon and having an inverse tapered shape;

interlocking the first and second pattern spacers using a vacuum between the first and second substrates;

curing the seal pattern; and

injecting liquid crystal to form a liquid crystal layer.

24. The method according to claim 17, wherein the providing a second substrate above the first substrate comprises:

forming an upper electrode on the black matrix layer and the color filter layer;

forming a photoresist film on the upper electrode; and

exposing and developing the photoresist film to form the second pattern spacer having an inverse tapered shape.

\* \* \* \* \*

专利名称(译)	液晶显示装置及其制造方法		
公开(公告)号	<a href="#">US20070070284A1</a>	公开(公告)日	2007-03-29
申请号	US11/372082	申请日	2006-03-10
[标]申请(专利权)人(译)	乐金显示有限公司		
申请(专利权)人(译)	LG.PHILIPS LCD CO. , LTD.		
当前申请(专利权)人(译)	LG DISPLAY CO. , LTD.		
[标]发明人	LEE JOON SUK JEE YOUNG SEUNG KIM JEONG OH		
发明人	LEE, JOON SUK JEE, YOUNG SEUNG KIM, JEONG OH		
IPC分类号	G02F1/1339		
CPC分类号	G02F1/13394		
优先权	1020050090417 2005-09-28 KR		
其他公开文献	US7576827		
外部链接	<a href="#">Espacenet</a> <a href="#">USPTO</a>		

摘要(译)

一种液晶显示装置，包括：第一基板，具有多条栅极线和多条彼此交叉的数据线；面向第一基板的第二基板；第一图案间隔物，在第一基板的内表面上具有倒锥形形状；第二图案间隔物，在第二基板的内表面上具有倒锥形形状；在第一和第二基板的外围边缘上的密封图案；以及第一和第二基板之间的液晶层。

