



(19) **United States**

(12) **Patent Application Publication** (10) **Pub. No.: US 2004/0246219 A1**

Moon

(43) **Pub. Date: Dec. 9, 2004**

(54) **LIQUID CRYSTAL DISPLAY AND DRIVING METHOD THEREOF**

(76) Inventor: **Seung-Hwan Moon, Yongin-city (KR)**

Correspondence Address:
McGuire Woods LLP
Suite 1800
1750 Tysons Boulevard
McLean, VA 22102 (US)

the data line; a gate driver applying a gate signal for controlling the switching element to the gate line; and a data driver selecting gray voltages corresponding to gray signals and applying the selected gray voltages to the data line. The gate signal includes a gate-on voltage for turning on the switching element and a gate-off voltage for turning off the switching element. The gray voltages include pairs of positive and negative voltages (V^+ , V^-) and

(21) Appl. No.: **10/664,075**

$$\frac{V^+ + V^-}{2} = V_{const}$$

(22) Filed: **Sep. 17, 2003**

(30) **Foreign Application Priority Data**

Sep. 17, 2002 (KR) 10-2002-0056508

for each gray, where V_{const} indicates a predetermined level. The gate-on voltage continuously decreases from a first level to a second level for a predetermined time, and the first level (V_{on1}) and the second level (V_{on2}) satisfy a relation given by,

Publication Classification

(51) **Int. Cl.⁷ G09G 3/36**

(52) **U.S. Cl. 345/89**

$$\frac{V_{on1} + V_{const}}{2} - \frac{V_{on1} + V_{const}}{2} \times$$

(57) **ABSTRACT**

$$10\% \leq V_{on2} \leq \frac{V_{on1} + V_{const}}{2} + \frac{V_{on1} + V_{const}}{2} \times 10\%$$

A liquid crystal display is provided, which includes: a liquid crystal panel including a gate line, a data line, and a pixel including a switching element connected to the gate line and

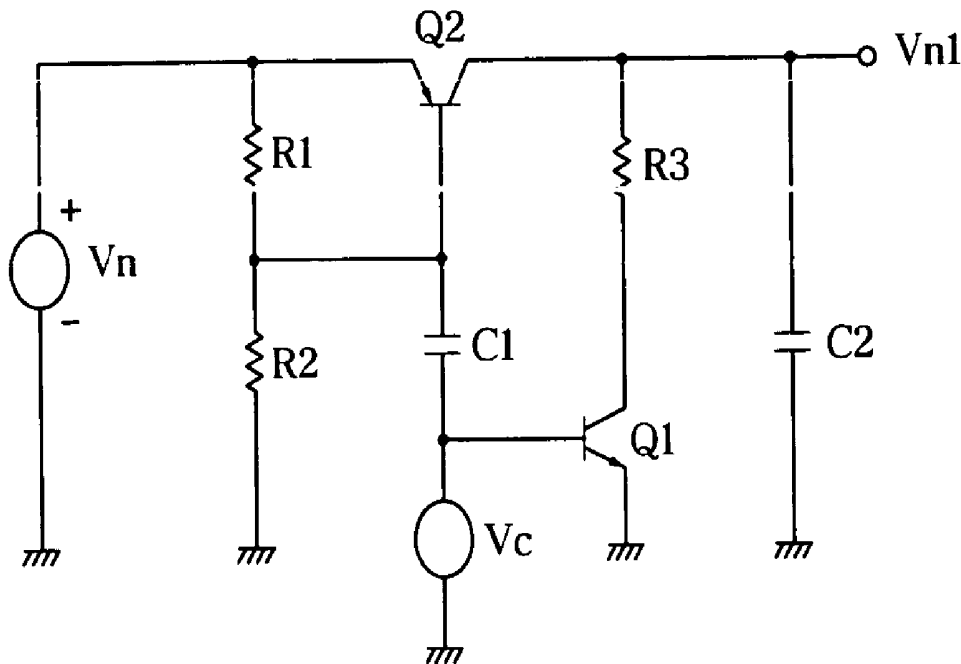

FIG. 1

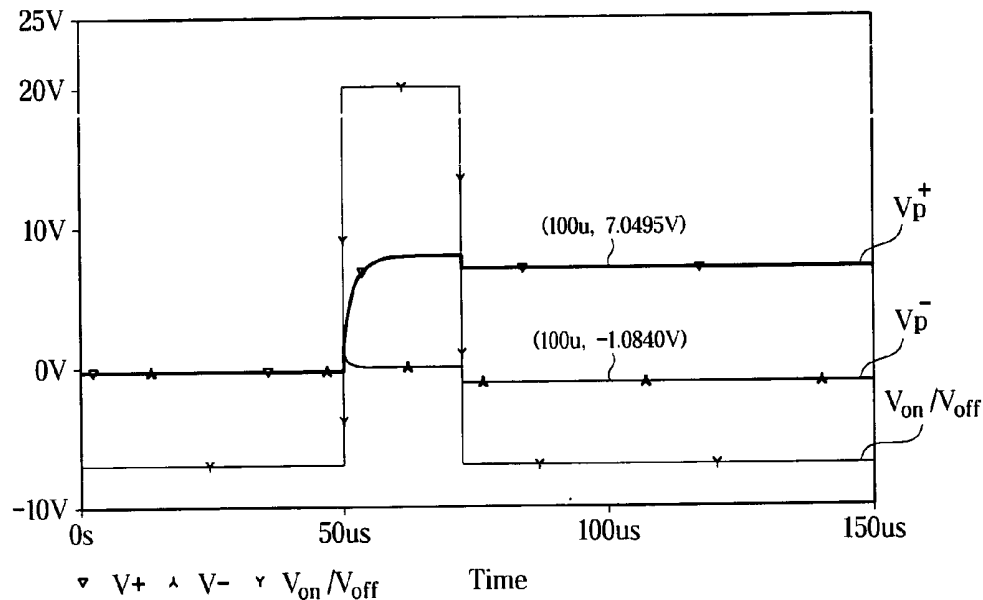

FIG. 2

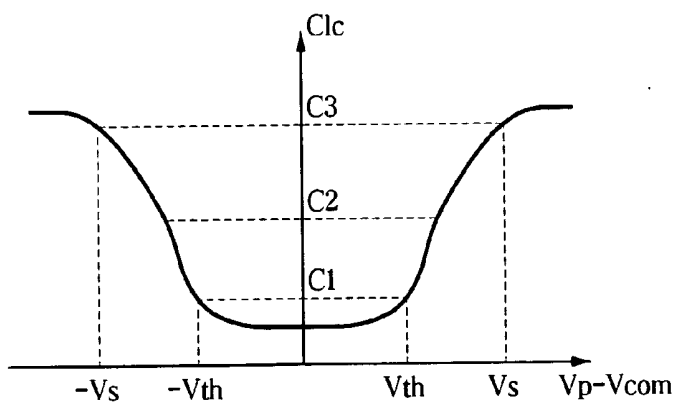

FIG. 3

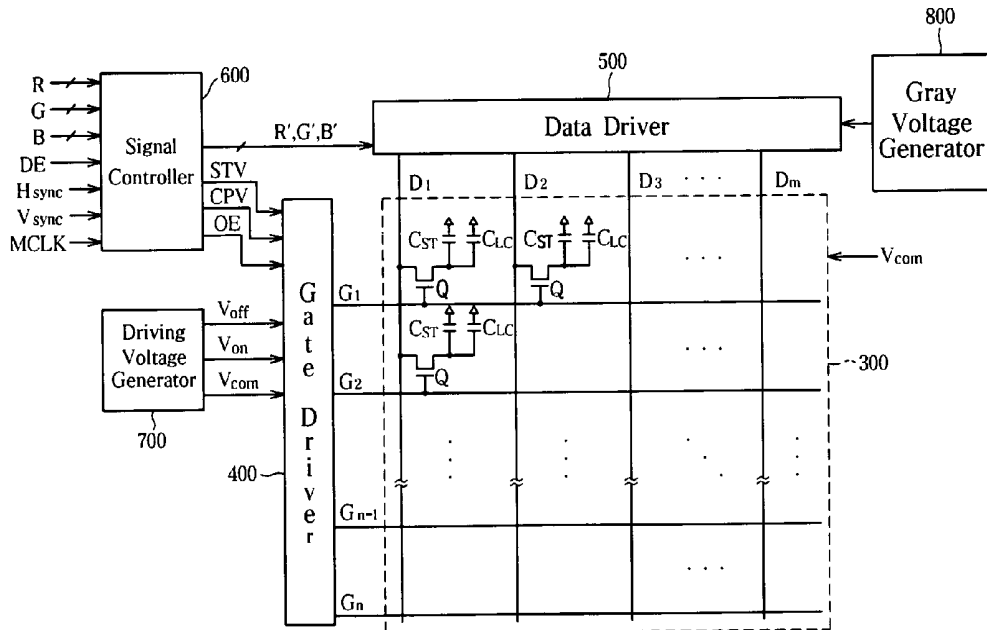

FIG. 4

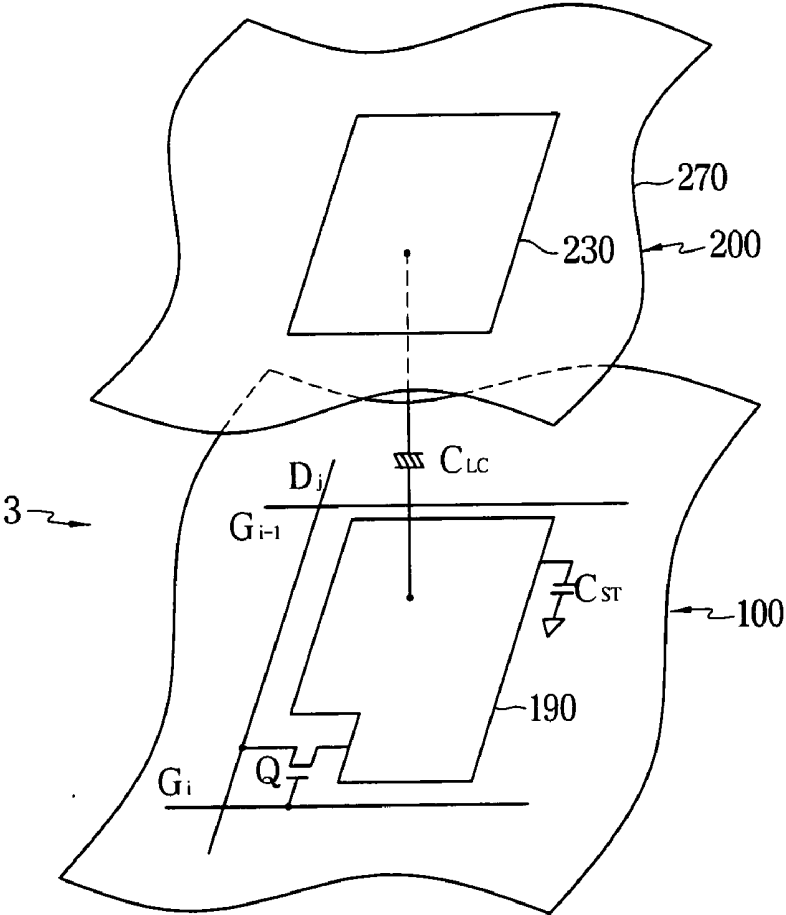

FIG. 5

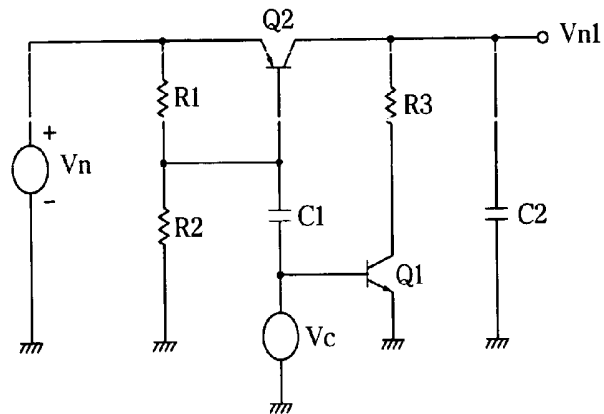

FIG. 6

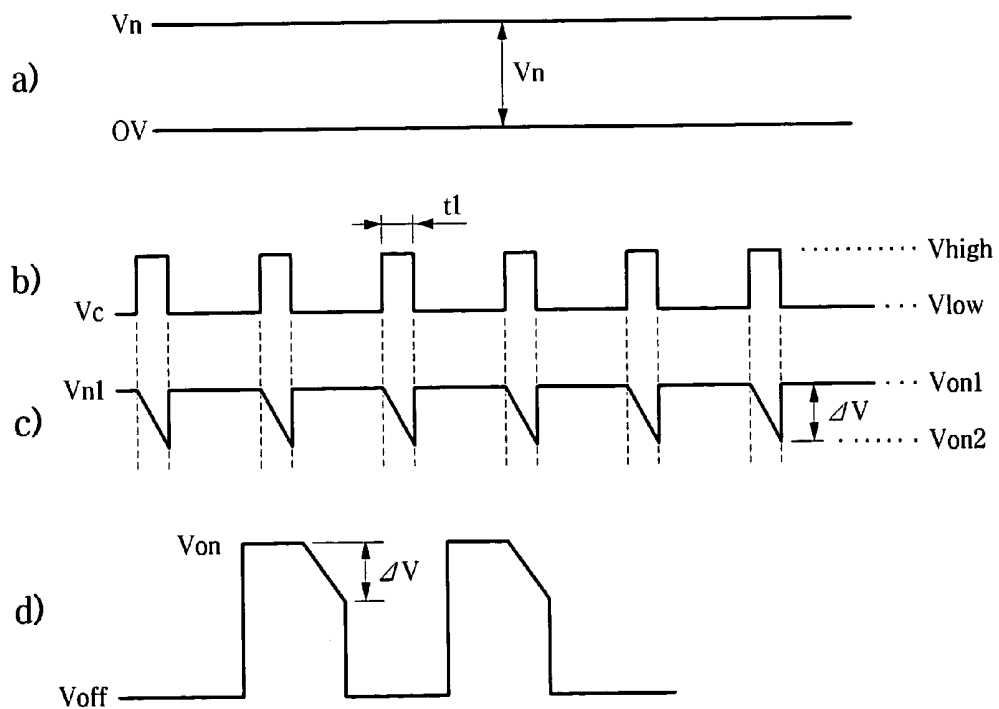

FIG. 7

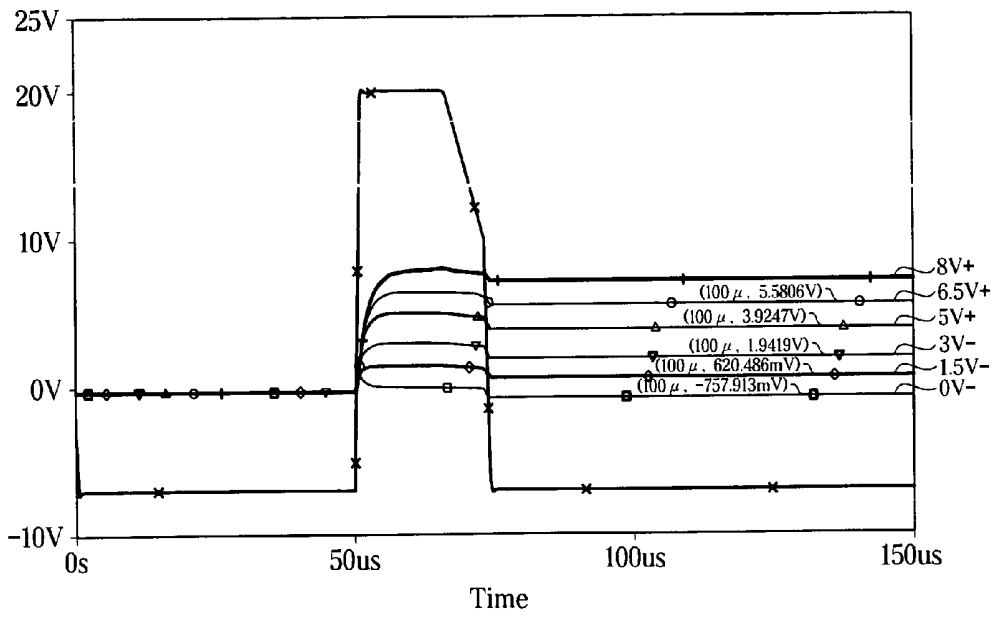

FIG. 8

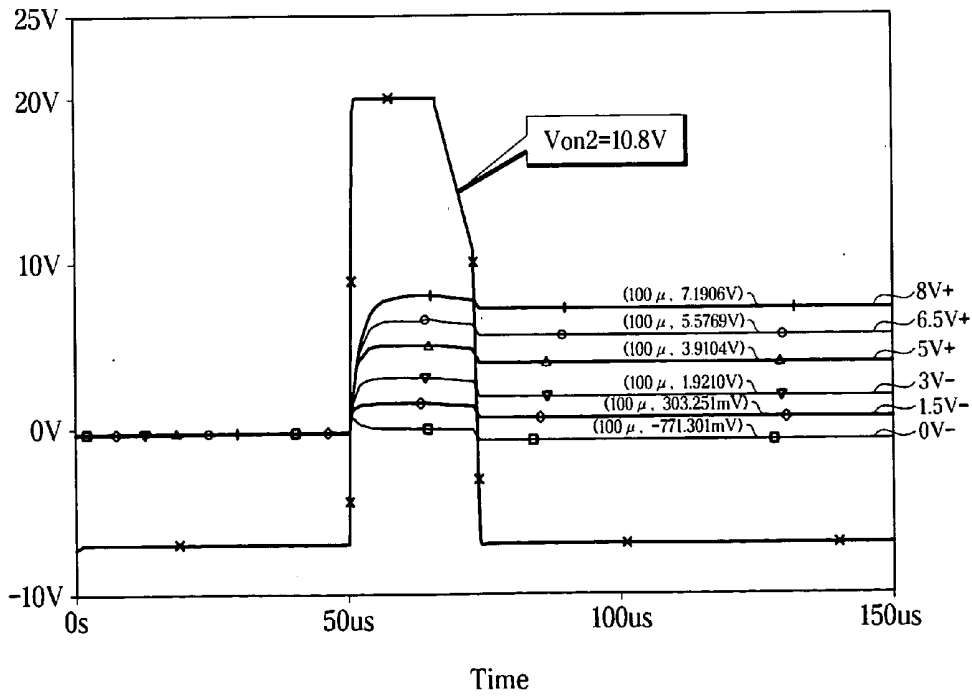

FIG. 9

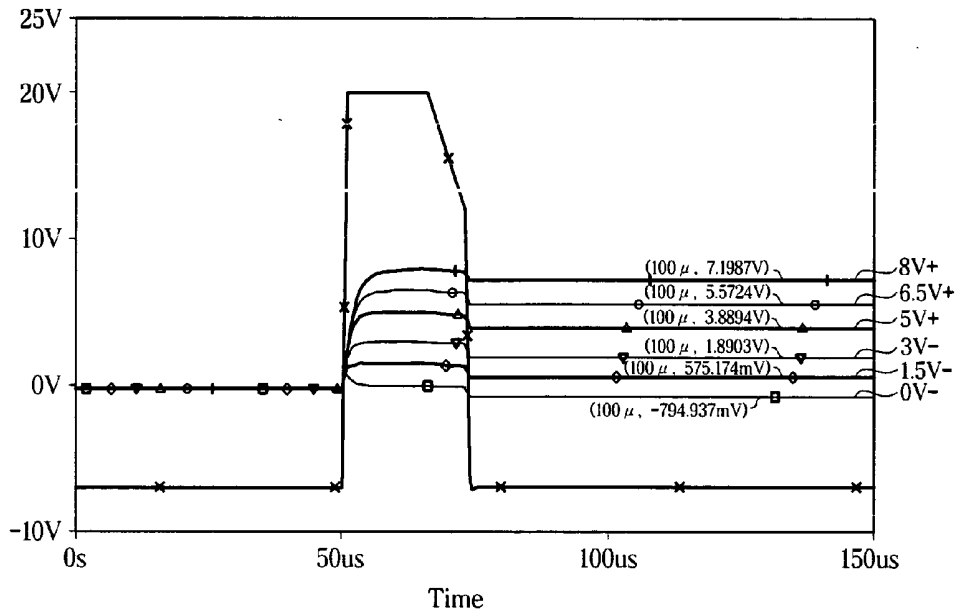

FIG. 10

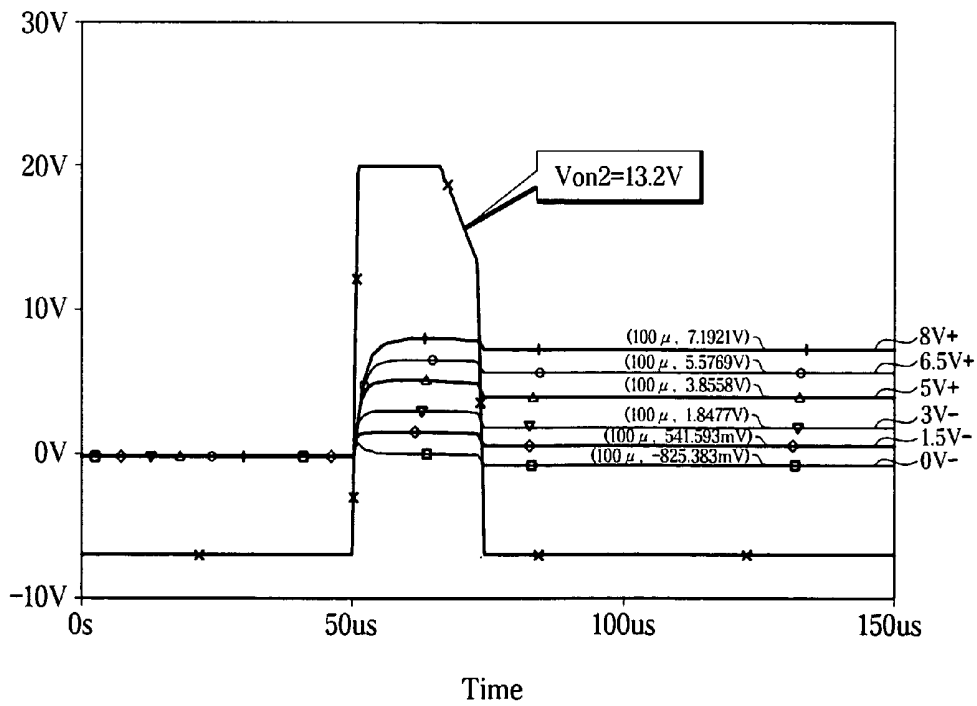
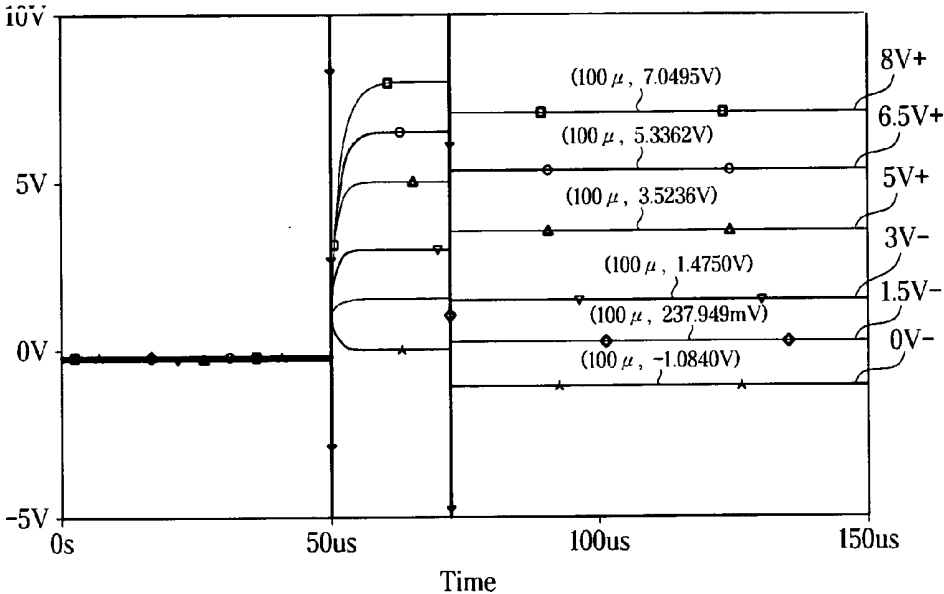

FIG. 11



LIQUID CRYSTAL DISPLAY AND DRIVING METHOD THEREOF

CROSS REFERENCE TO RELATED APPLICATION

[0001] This application claims the benefit of Korean Patent Application No. 10-2002-0056508 filed in the Korean Intellectual Property Office on Sep. 17, 2002, which is hereby incorporated by reference in its entirety for all purposes as if fully set forth herein.

BACKGROUND OF THE INVENTION

[0002] (a) Field of the Invention

[0003] The present invention relates to a liquid crystal display and a driving method thereof.

[0004] (b) Description of the Related Art

[0005] Liquid crystal displays (LCDs) include two panels provided with pixel electrodes and a common electrode and coated with alignment layers and a liquid crystal (LC) layer with dielectric anisotropy, which is interposed between the two panels. The pixel electrodes are arranged in a matrix and connected to switching elements such as thin film transistors (TFTs). The switching elements selectively transmit data voltages from data lines in response to gate signals from gate lines. The common electrode covers entire surface of one of the two panels and is supplied with a common voltage. The pixel electrode, the common electrode, and the LC layer form a LC capacitor in circuitual view, which is a basic element of a pixel along with the switching element connected thereto. Each pixel further includes a storage capacitor for enhancing the capacitance of the LC capacitor.

[0006] In the LCD, voltages are applied to the two electrodes to generate electric field in the LC layer, and the transmittance of light passing through the LC layer is adjusted by controlling the strength of the electric field, thereby obtaining desired images. In order to prevent image deterioration due to long-time application of the unidirectional electric field, polarity of data voltages with respect to the common voltage is reversed every frame, every row, or every dot.

[0007] When the LCD displays motion images or displays still images for a time interval, an afterimage is generated. The exemplary factors causing the afterimage are the concentration of ion impurity in the LC layer, the strength of the aligning force of the alignment layer, the kickback voltage, etc.

[0008] For example, ion impurity in the LC layer may be adsorbed due to inappropriate concentration thereof. The pixels are biased with a DC voltage generated by the ions even though there is no applied external field. The DC voltage affects the LC molecules to generate the afterimage.

[0009] The kickback voltage is a voltage drop before and after a voltage transition of a gate signal from a gate-on voltage for turning on the switching elements to a gate-off voltage for turning off the switching elements. The kickback voltage reduces both the positive data voltage and the negative data voltage to cause a DC voltage.

[0010] For reducing the afterimage, the concentration of the ion impurity in the LC layer is optimized, the aligning force of the alignment layer is maximized, and the kickback voltage is reduced.

[0011] A conventional technique for reducing afterimage generated due to the kickback voltage is to control the common voltage such that the voltages of the pixel electrode are symmetrical with respect to the common voltage. It is assumed that the positive data voltage and a negative data voltage for a gray to be applied to the pixel electrode are denoted as V^+ and V^- , respectively, and the kickback voltage is denoted as V_k . Then, the voltages of the pixel electrode are $(V^+ - V_k)$ for the positive data voltage V^+ and $(V^- - V_k)$ for the negative data voltage V^- . The common voltage V_{com} is determined by a following equation:

$$(V^+ - V_k) - V_{com} = V_{com} - (V^- - V_k). \quad (1)$$

[0012] However, it is difficult to make the common voltage V_{com} satisfy Equation 1 for all grays and, if possible, the established common voltage may not remove the afterimage.

SUMMARY OF THE INVENTION

[0013] A motivation of the present invention is to solve the problems of the conventional art.

[0014] A liquid crystal display is provided, which includes: a liquid crystal panel including a gate line, a data line, and a pixel including a switching element connected to the gate line and the data line; a gate driver applying a gate signal for controlling the switching element to the gate line; and a data driver selecting gray voltages corresponding to gray signals and applying the selected gray voltages to the data line, wherein the gate signal includes a gate-on voltage for turning on the switching element and a gate-off voltage for turning off the switching element and the gate-on voltage has at least two different levels.

[0015] Preferably, the gate-on voltage continuously varies for a predetermined time, and in particular, the gate-on voltage continuously decreases from a first level to a second level for the predetermined time.

[0016] The first level (V_{on1}) and the second level (V_{on2}) preferably satisfy a relation given by,

$$\frac{V_{on1} + V_{const}}{2} - \frac{V_{on1} + V_{const}}{2} \times 10\% \leq V_{on2} \leq \frac{V_{on1} + V_{const}}{2} + \frac{V_{on1} + V_{const}}{2} \times 10\%,$$

[0017] where V_{const} indicates a predetermined voltage level.

[0018] The gray voltages include a plurality of pairs of a positive voltage (V^+) and a negative voltage (V^-) assigned to each gray and it is preferable that

$$\frac{V^+ + V^-}{2} = V_{const}$$

[0019] for each gray.

[0020] The continuous decrease of the gate-on voltage from the first level to the second level is preferably linear.

[0021] The continuous decrease of the gate-on voltage from the first level to the second level is preferably performed around a time when the gate signal moves from the gate-on voltage to the gate-off voltage. The gate-on voltage preferably reaches the second level at a time when the gate signal moves from the gate-on voltage to the gate-off voltage.

[0022] Preferably, the liquid crystal display further includes a voltage generator including: a first switch selectively transmitting a first voltage; a first capacitor connected to the first switch and charging a voltage from the first switch; and a second switch connected to the first capacitor and forming a discharging path of the voltage charged in the first capacitor.

[0023] The voltage generator may further include a resistor connected between the second switch and the first capacitor and the first switch discharges according to a time constant determined by a resistance of the resistor and a capacitance of the capacitor.

[0024] The voltage generator may further include: a signal generator for generating a pulse signal with a predetermined period; a voltage divider dividing the first voltage; and a second capacitor for charging a voltage from the voltage divider for turning on and turning off the first switch responsive to the pulse signal from the signal generator. Preferably, the first switch and the second switch are alternately activated based on the pulse signal from the signal generator.

[0025] The first switch may include a PNP bipolar transistor and the second switch may include an NPN bipolar transistor.

[0026] Preferably, the signal generator is connected to a base of the PNP bipolar transistor and is connected to a base of the NPN bipolar transistor via the first capacitor.

[0027] The voltage divider preferably includes comprises a first resistor and a second resistor connected in series between the first voltage and a ground and is connected to a base of the PNP generator, and

$$\frac{V_{be2}}{V_n} \leq \frac{1}{1 + (R_2 / R_1)} < \frac{V_{be2} + (V_{high} - V_{low})}{V_n},$$

[0028] where R1 and R2 are resistances of the first and the second resistors, respectively, Vbe2 is a base-emitter voltage of the PNP transistor, Vn is a value of the first voltage, and Vhigh and Vlow are high and low levels of the pulse signal of the signal controller, respectively.

[0029] A method of driving a liquid crystal display including a plurality of gate lines, a plurality of data lines, and a plurality of pixels including switching elements connected to the gate lines and the data lines is provided, which includes: generating a plurality of pairs of a positive gray voltage (V+) and a negative gray voltage (V-) for respective grays satisfying

$$\frac{V^+ + V^-}{2} = V_{const}$$

[0030] where Vconst is a predetermined value; generating a gate signal including a gate-on voltage for turning on the switching element and a gate-off voltage for turning off the switching element; applying the gate signal to the gate lines; and applying the gray signals to the data lines, wherein the gate-on voltage decreases from a first level (Von1) to a second level (Von2) for a predetermined time and

$$\frac{Von1 + V_{const}}{2} - \frac{Von1 + V_{const}}{2} \times 10\% \leq Von2 \leq \frac{Von1 + V_{const}}{2} + \frac{Von1 + V_{const}}{2} \times 10\%.$$

BRIEF DESCRIPTION OF THE DRAWINGS

[0031] The above and other advantages of the present invention will become more apparent by describing preferred embodiments thereof in detail with reference to the accompanying drawings in which:

[0032] FIG. 1 is a graph showing waveforms of a gate signal and voltages of a pixel electrode according to an experiment of the present invention;

[0033] FIG. 2 is a graph showing a LC capacitance of a normally white twisted nematic (TN) mode LCD as function of a pixel voltage across a LC capacitor;

[0034] FIG. 3 is a block diagram of an LCD according to an embodiment of the present invention;

[0035] FIG. 4 is an equivalent circuit diagram of a pixel of an LCD according to an embodiment of the present invention;

[0036] FIG. 5 is an exemplary circuit diagram of a gate-on voltage generating circuit for generating a gate-on voltage according to an embodiment of the present invention;

[0037] FIG. 6 shows waveforms of signals generated in the signal generator shown in FIG. 5; and

[0038] FIGS. 7-11 are graphs showing waveforms of a gate signal Von/Voff including a gate-on voltage Von and a gate-off voltage Voff and a voltage of a pixel electrode according to experiments of the present invention.

DETAILED DESCRIPTION OF PREFERRED EMBODIMENTS

[0039] The present invention now will be described more fully hereinafter with reference to the accompanying drawings, in which preferred embodiments of the invention are shown. This invention may, however, be embodied in many different forms and should not be construed as limited to the embodiments set forth herein.

[0040] In the drawings, the thickness of layers and regions are exaggerated for clarity. Like numerals refer to like elements throughout. It will be understood that when an element such as a layer, region or substrate is referred to as

being “on” another element, it can be directly on the other element or intervening elements may also be present. In contrast, when an element is referred to as being “directly on” another element, there are no intervening elements present.

[0041] The inventors found that the conventional method indicated by Equation 1 may not completely solve the afterimage problem in an LCD due to the kickback voltage.

[0042] The kickback voltage V_k is determined by a following equation:

$$V_k = \frac{C_{gd}}{C_{gd} + C_{ST} + C_{LC}}(V_{on} - V_{off}), \quad (2)$$

[0043] where C_{gd} is a gate-drain parasitic capacitance between a gate and a drain of a TFT, C_{LC} is a capacitance of a LC capacitor (referred to as “LC capacitance” hereinafter), C_{ST} is a capacitance of a storage capacitor (referred to as “storage capacitance” hereinafter), V_{on} is a gate-on voltage, and V_{off} is a gate-off voltage.

[0044] First, the kickback voltage V_k for a positive voltage V^+ and a negative gray voltage V^- for a gray is not equal since the parasitic capacitance C_{gd} is varied depending on a voltage applied to a pixel electrode.

[0045] The gate-drain capacitance C_{gd} sharply varies depending on a gate-drain voltage V_{gd} , which is a voltage difference between the gate and the drain of the TFT, equal to or higher than a threshold voltage of the TFT. In detail, the gate-drain capacitance C_{gd} increases as the gate-drain voltages V_{gd} increases. The respective gate-drain voltages V_{gd}^+ and V_{gd}^- when applying the positive gray voltage V^+ and the negative gray voltage V^- are:

$$\begin{aligned} V_{gd}^+ &= V_{on} - V^+; \text{ and} \\ V_{gd}^- &= V_{on} - V^-. \end{aligned} \quad (3)$$

[0046] Accordingly, a relation $V_{gd}^- > V_{gd}^+$ is always satisfied and thus the gate-drain capacitance C_{gd} under the application of the positive gray voltage V^+ is smaller than the gate-drain capacitance C_{gd} under the application of the negative gray voltage V^- . As a result, a kickback voltage V_k^+ under the application of the positive gray voltage V^+ and a kickback voltage V_k^- under the application of the negative gray voltage V^- satisfy a relation $V_k^- > V_k^+$.

[0047] FIG. 1 is a graph showing waveforms of a gate signal V_{on}/V_{off} and voltages V_p^+ and V_p^- of a pixel electrode according to an experiment of the present invention.

[0048] The gate signal V_{on}/V_{off} including a low level (i.e., a gate-off voltage V_{off}) of about $-7V$ and a high level (i.e., a gate-on voltage V_{on}) of about $20V$ was applied to a pixel electrode. The value of a common voltage V_{com} applied to a common electrode opposite the pixel electrode was $4V$ and positive and negative gray voltages V^+ and V^- applied to the pixel electrode were $8V$ and $0V$, respectively. V_p^+ and V_p^- indicate the voltage of the pixel electrode under the application of the positive gray voltage V^+ and under the application of the negative gray voltage V^- , respectively. The gate-on voltage V_{on} was applied to the pixel electrode from about 50 microseconds for about 25 microseconds.

[0049] The measured voltage V_p^+ of the pixel electrode before and after the voltage transition from the high level to the low level was about $8V$ and about $7.0495V$, respectively, and the measured voltage V_p^- of the pixel electrode before and after the voltage transition from the high level to the low level was about $0V$ and about $-1.0840V$. Accordingly, the kickback voltage V_k^+ under the application of the positive gray voltage V^+ is equal to about $(8-7.0495)=0.9505V$, while kickback voltage V_k^- under the application of the negative gray voltage V^- is equal to about $(0-(-1.0840))=1.0840V$. The kickback voltages V_k^+ and V_k^- are different from each other and satisfy the relation $V_k^- > V_k^+$.

[0050] Second, the kickback voltage V_k varies depending on the grays since the LC capacitance C_{LC} varies depending on the grays.

[0051] FIG. 2 is a graph showing the LC capacitance C_{LC} of a normally white twisted nematic (TN) mode LCD as a function of a pixel voltage ($=V_p - V_{com}$) across the LC capacitor, i.e., a voltage difference between a voltage V_p of a pixel electrode and a common voltage V_{com} . As shown in FIG. 2, the LC capacitance C_{LC} varies depending on the pixel voltage ($V_p - V_{com}$) while it exhibits a symmetry with respect to zero pixel voltage. In particular, the LC capacitance C_{LC} drastically varies for the pixel voltages ($V_p - V_{com}$) between V_{th} and V_s , and the LC capacitances C_{LC} for the pixel voltages ($V_p - V_{com}$) of V_{th} and V_s are indicated by C1 and C3, while C2 is an intermediate value between C1 and C3.

[0052] Now, liquid crystal displays according to embodiments of the present invention will be described.

[0053] FIG. 3 is a block diagram of an LCD according to an embodiment of the present invention, and FIG. 4 is an equivalent circuit diagram of a pixel of an LCD according to an embodiment of the present invention.

[0054] Referring to FIG. 3, an LCD according to an embodiment includes an LC panel assembly 300, a gate driver 400 and a data driver 500 which are connected to the panel assembly 300, a driving voltage generator 700 connected to the gate driver 400, a gray voltage generator 800 connected to the data driver 500, and a signal controller 600 controlling the above elements.

[0055] In circuitual view, the panel assembly 300 includes a plurality of display signal lines $G_1 - G_n$ and $D_1 - D_m$ and a plurality of pixels connected thereto and arranged substantially in a matrix. In structural view shown in FIG. 4, the panel assembly 300 includes a lower panel 100, an upper panel 200 opposite the lower panel 100, and a LC layer 3 interposed therebetween.

[0056] The display signal lines $G_1 - G_n$ and $D_1 - D_m$ are provided on the lower panel 100, and include a plurality of gate lines $G_1 - G_n$ transmitting gate signals (also referred to as “scanning signals”) and a plurality of data lines $D_1 - D_m$ transmitting data signals. The gate lines $G_1 - G_n$ extend substantially in a row direction and substantially parallel to each other, while the data lines $D_1 - D_m$ extend substantially in a column direction and substantially parallel to each other.

[0057] Each pixel includes a switching element Q connected to the signal lines $G_1 - G_n$ and $D_1 - D_m$, and a LC capacitor C_{LC} and a storage capacitor C_{ST} that are connected to the switching element Q. If necessary, the storage capacitor C_{ST} may be omitted.

[0058] The switching element Q is provided on the lower panel 100 and has three terminals, a control terminal connected to one of the gate lines G_1 - G_n , an input terminal connected to one of the data lines D_1 - D_m , and an output terminal connected to both the LC capacitor C_{LC} and the storage capacitor C_{ST} . FIGS. 3 and 4 show MOS transistors as the switching elements, which are implemented as TFTs including channel layers of amorphous silicon or polysilicon.

[0059] The LC capacitor C_{LC} includes a pixel electrode 190 provided on the lower panel 100 and a common electrode 270 provided on the upper panel 200 as two terminals. The LC layer 3 disposed between the two electrodes 190 and 270 functions as dielectric of the LC capacitor C_{LC} . The pixel electrode 190 is connected to the switching element Q and the common electrode 270 is connected to the common voltage V_{com} and covers entire surface of the upper panel 200. Unlike FIG. 4, the common electrode 270 may be provided on the lower panel 100, and both electrodes 190 and 270 have shapes of bar or stripe.

[0060] The storage capacitor C_{ST} is defined by the overlap of the pixel electrode 190 and a separate wire (not shown) provided on the lower panel 100 and applied with a predetermined voltage such as the common voltage V_{com} . Otherwise, the storage capacitor C_{ST} is defined by the overlap of the pixel electrode 190 and its previous gate line G_{i-1} via an insulator.

[0061] For color display, each pixel can represent one of three primary colors such as red, green and blue by providing corresponding one of a plurality of color filters 230 in an area corresponding to the pixel electrode 190. The color filter 230 shown in FIG. 4 is provided in the corresponding area of the upper panel 200. Alternatively, the color filters 230 are provided on or under the pixel electrode 190 on the lower panel 100.

[0062] A pair of polarizers (not shown) polarizing incident light are attached on the outer surfaces of the panels 100 and 200 of the panel assembly 300.

[0063] Referring to FIG. 3 again, the gray voltage generator 800 generates two sets of a plurality of gray voltages related to the transmittance of the pixels. The gray voltages in one set have a positive polarity with respect to the common voltage V_{com} , while those in the other set have a negative polarity with respect to the common voltage V_{com} . The positive gray voltage V^+ and the negative gray voltage V^- for any gray satisfy a relation,

$$\frac{V^+ + V^-}{2} = V_{const}, \quad (4)$$

[0064] where V_{const} indicates a predetermined constant voltage.

[0065] The driving voltage generator 700 generates a gate-on voltage V_{on} for turning on the switching elements Q and a gate-off voltage V_{off} for turning off the switching elements Q. The gate-on voltage V_{on} has a high value V_{on1} for a predetermined duration while it has a sawtooth shape falling down from the high value V_{on1} to a low value V_{on2}

during a remaining duration. The low value V_{on2} of the gate-on voltage V_{on} is preferably given by:

$$\frac{V_{on1} + V_{const}}{2} - \frac{V_{on1} + V_{const}}{2} \times \quad (5)$$

$$10\% \leq V_{on2} \leq \frac{V_{on1} + V_{const}}{2} + \frac{V_{on1} + V_{const}}{2} \times 10\%.$$

[0066] The gate driver 400 is connected to the gate lines G_1 - G_n of the panel assembly 300 and applies gate signals to the gate lines G_1 - G_n , each gate signal being a combination of the gate-on voltage V_{on} and the gate-off voltage V_{off} . The gate-on voltage V_{on} in the gate signal is gradually reduced from the high value V_{on1} to the low value V_{on2} near the voltage transition of the gate signal from the gate-on voltage V_{on} to the gate-off voltage V_{off} . For example, the gate-on voltage V_{on} has the high value V_{on1} before the voltage transition of the gate signal, the magnitude of the gate-on voltage V_{on} gradually decreases as the time becomes close to the voltage transition, and the gate-on voltage V_{on} has the low value V_{on2} at the voltage transition.

[0067] The data driver 500 is connected to the data lines D_1 - D_m of the panel assembly 300 and selects gray voltages from the gray voltage generator 800 to apply as data signals to the data lines D_1 - D_m .

[0068] The gate driver 400 and the data driver 500 may include a plurality of gate driving integrated circuits (ICs) and a plurality of data driving ICs, respectively. The ICs are separately placed external to the panel assembly 300 or mounted on the panel assembly 300. Alternatively, the ICs are formed on the panel assembly 300 like the signal lines G_1 - G_n and D_1 - D_m and the TFTs Q.

[0069] The signal controller 600 controls the gate driver 400, the data driver 500, and so on.

[0070] Then, operations of the LCD will be described with in detail.

[0071] The signal controller 600 is supplied from an external graphic controller (not shown) with RGB image signals R, G and B and input control signals controlling the display thereof, for example, a vertical synchronization signal V_{sync} , a horizontal synchronization signal H_{sync} , a main clock CLK, a data enable signal DE, etc. The signals controller 600 generates a plurality of gate control signals and a plurality of data control signals and processes the image signals R, G and B for the LC panel assembly 300 on the basis of the input control signals. The signal controller 600 provides the gate control signals for the gate driver 400 and the data control signals and the processed image signals R', G' and B' for the data driver 500.

[0072] The gate control signals include a vertical synchronization start signal STV for informing of start of a frame, a gate clock signal CPV for controlling the output time of the gate-on voltage V_{on} and an output enable signal OE for defining the duration of the gate-on voltage V_{on} .

[0073] The data control signals include a horizontal synchronization start signal STH for informing of start of a horizontal period, a load signal LOAD or TP for instructing to apply the appropriate data voltages to the data lines D_1 - D_m , an inversion control signal RVS for reversing the

polarity of the data voltages (with respect to the common voltage V_{com}), and a data clock signal HCLK.

[0074] The data driver **500** receives a packet of the image data R', G' and B' for a pixel row from the signal controller **600** and converts the image data R', G' and B' into analog data voltages selected from the gray voltages from the gray voltage generator **570** in response to the data control signals from the signal controller **600**.

[0075] Responsive to the gate control signals from the signal controller **600**, the gate driver **400** applies the gate-on voltage V_{on} to the gate line G_1 - G_n , thereby turning on the switching elements Q connected thereto.

[0076] The data driver **500** applies the data voltages to the corresponding data lines D_1 - D_m during an on time of the switching elements Q due to the application of the gate-on voltage V_{on} to gate lines G_1 - G_n connected to the switching elements Q (which is called "one horizontal period" or "1H" and equals to one periods of the horizontal synchronization signal Hsync, the data enable signal DE, and the gate clock signal CPV). Then, the data voltages in turn are supplied to the corresponding pixels via the activated switching elements Q.

[0077] The difference between the data voltage and the common voltage V_{com} applied to a pixel is expressed as a charged voltage of the LC capacitor C_{LC} , i.e., a pixel voltage. The LC molecules have orientations depending on the magnitude of the pixel voltage and the orientations determine the polarization of light passing through the LC capacitor C_{LC} . The polarizers convert the light polarization into the light transmittance.

[0078] By repeating this procedure, all gate lines G_1 - G_n are sequentially supplied with the gate-on voltage V_{on} during a frame, thereby applying the data voltages to all pixels. When the next frame starts after finishing one frame, the inversion control signal RVS applied to the data driver **500** is controlled such that the polarity of the data voltages is reversed (which is called "frame inversion"). The inversion control signal RVS may be also controlled such that the polarity of the data voltages flowing in a data line in one frame is reversed (which is called "line inversion") or the polarity of the data voltages in one packet is reversed (which is called "dot inversion").

[0079] Now, a driving voltage generator for an LCD according to an embodiment of the present invention is described with reference to **FIGS. 5 and 6**.

[0080] **FIG. 5** is an exemplary circuit diagram of a gate-on voltage generating circuit of a driving voltage generator for generating a gate-on voltage according to an embodiment of the present invention.

[0081] Referring to **FIG. 5**, a gate-on voltage generating circuit according to an embodiment of the present invention includes a voltage divider including two resistors R1 and R2 connected in series between a voltage source V_n and a ground, an NPN transistor Q1, a PNP transistor Q2, a switching controller Vc, two capacitors C1 and C2, and a resistor R3.

[0082] The transistor Q2 has an emitter connected to the voltage source V_n , a base connected to the voltage divider R1 and R2, and a collector connected to an output V_{n1} of the generator. The capacitor C1 is connected between the base

of the transistor Q2 and the switch controller Vc, which is connected between the capacitor C1 and the ground and generates a periodic signal. The transistor Q1 has an emitter connected to the ground, a base connected to the switch controller Vc, and a collector connected to the output V_{n1} through the resistor R3. The capacitor C2 is connected between the output V_{n1} and the ground and may be a separate electronic element or may indicate a parasitic capacitor in an output path.

[0083] Now, the operation of the gate-on voltage generation circuit shown in **FIG. 5** is described in detail with reference to **FIG. 6**, which shows waveforms of signals generated therein.

[0084] The output signals of the voltage source V_n and of the switch controller Vc are indicated by the same reference characters as the voltage source V_n and the switch controller Vc, respectively, and the resistances of the resistors R1, R2 and R3 and the capacitances of the capacitors C1 and C2 are indicated by the same reference characters as the resistors R1, R2 and R3 and the capacitors C1 and C2, respectively. The output signal from the output V_{n1} is indicated by the same reference character as the output V_{n1} and used as a gate-on voltage V_{on} .

[0085] The voltage source V_n provides a DC voltage V_n as shown in **FIG. 6(a)** and the switching controller Vc generates a periodic voltage signal Vc having a high value V_{high} for a predetermined time t_1 and a low value V_{low} for the remaining time as shown in **FIG. 6(b)**. The voltage divider R1 and R2 drops the level of the voltage V_n from the voltage source Vc and the ratio of the resistances of the resistors R1 and R2 is determined by a reference to be described later.

[0086] When the voltage signal Vc from the switch controller Vc is the low level V_{low} , a voltage across the capacitor C1 is equal to the voltage V_n divided by the voltage divider R1 and R2 and applied to the base of the transistor Q2. The transistor Q2 is then turned on if appropriately determined resistances of the resistors R1 and R2 are given.

[0087] Then, the output voltage V_{n1} becomes to have a predetermined high level V_{on1} and the capacitor C2 is charged with the predetermined level of voltage.

[0088] When the voltage signal Vc from the switch controller Vc becomes the high level V_{high} , the voltage applied to the base of the transistor Q2 is abruptly increased since the voltage across the capacitor C1 tends to remain its level. The transistor Q2 is then turned off if appropriately determined resistances of the resistors R1 and R2 are given. The off state of the transistor Q2 can be remained for the time t_1 if the resistance of the resistors R1 and R2 and the capacitance of the capacitor C1 are appropriately determined.

[0089] In addition, the transistor Q1 turns on to form a discharging path for the voltage charged in the capacitor C2. Accordingly, the voltage across the capacitor C2 and the output voltage V_{n1} become decreased to a predetermined low level V_{on2} according to a time constant determined by the resistance of the resistor R3 and the capacitance of the capacitor C3, which exhibit a sawtooth wave as shown in **FIG. 6(c)**.

[0090] A voltage variation $\Delta V (=V_{on1}-V_{on2})$ of the output voltage V_{n1} is given by:

$$\Delta V = V_n \times \left(1 - \text{EXP} \left(-\frac{t1}{R3 \times C2} \right) \right) \quad (6)$$

[0091] Accordingly, the voltage variation ΔV is determined by the resistance $R3$ for fixed $t1$ and $C2$.

[0092] FIG. 6(d) shows a gate signal including a gate-on voltage V_{on} made of the output voltage V_{n1} of the gate-on voltage generation circuit.

[0093] Now, the conditions suitable for the operation of the gate-on voltage generator will be described.

[0094] The voltage drop across the resistor $R1$ is denoted as V_x , which is equal to

$$\frac{R1 \times V_n}{R1 + R2}$$

[0095] In order that the transistor $Q2$ is turned on by the voltage drop V_x when the voltage V_c has the low level V_{low} , the voltage drop V_x satisfies a following relation:

$$V_x = \frac{R1 \times V_n}{R1 + R2} \geq V_{be2}, \quad (7)$$

[0096] where V_{be2} is a base-emitter voltage of the transistor $Q2$. The voltage charged across the capacitor $C1$ equals to $(V_n - V_x)$.

[0097] When the output voltage of the switch controller V_c increases from V_{low} to V_{high} , the voltage applied to the base of the transistor $Q2$ is increased from $(V_n - V_x)$ to $((V_n - V_x) + (V_{high} - V_{low}))$. Then, the requirement for turn off the transistor $Q2$ is given:

$$(V_n - V_x) + (V_{high} - V_{low}) > V_n - V_{be2}. \quad (8)$$

[0098] From Relations 7 and 8, the ratio of the resistances $R1$ and $R2$ are determined by:

$$\frac{V_{be2}}{V_n} \leq \frac{1}{1 + (R2/R1)} < \frac{V_{be2} + (V_{high} - V_{low})}{V_n}. \quad (9)$$

[0099] In the meantime, the off state of the transistor $Q2$ is required to maintain for the time $t1$ as described above.

[0100] For example, it is assumed that $V_x = V_{be}$ and the discharged charge is indicated by Q_d .

[0101] Ignoring the discharge by the resistors $R1$ and $R2$, the amount of charges discharged by the transistor $Q2$ for the time $t1$ is equal to $I_b \times t1$, where I_b indicates a base current of the transistor $Q2$. Since the charge increment stored in the capacitor $C1$ is equal to $C1 \times (V_{high} - V_{low})$, a relation $Q_d = I_b \times t1 < C1 \times (V_{high} - V_{low})$ is satisfied. Accordingly, the capacitance $C1$ satisfies a following relation:

$$C1 > I_b \times t1 / (V_{high} - V_{low}), \quad (10)$$

[0102] and accordingly,

$$C1 > I_b \times t1. \quad (11)$$

[0103] Considering the discharge of the resistor $R1$, a following relation is satisfied:

$$R1 \times C1 \gg t1 \text{ or } R1 \gg \frac{t1}{C1}. \quad (12)$$

[0104] FIGS. 7-11 are graphs showing waveforms of a gate signal V_{on}/V_{off} including a gate-on voltage V_{on} and a gate-off voltage V_{off} and a voltage of a pixel electrode according to experiments of the present invention.

[0105] Positive gray voltages applied to the pixel electrode were about 5V, 6.5V and 8V and negative gray voltages applied to the pixel electrode were about 3V, 1.5V and 0V, respectively. A high value V_{on1} of the gate-on voltage V_{on} was about 20V and the gate-off voltage V_{off} was about -7V. The gate-on voltage V_{on} was applied to the pixel electrode from about 50 microseconds for about 25 microseconds.

[0106] The voltage V_{const} in Equation 4 is equal to about 4V, and a low value V_{on2} of the gate-on voltage V_{on} determined by Relation 5 ranges about 10.8V to about 13.2V, which are averaged to about 12V.

[0107] FIGS. 7, 8, 9 and 10 represent cases that the low values V_{on2} are 10V, 10.8V, 12V and 13.2V, respectively, while FIG. 11 represents a case that the gate-on voltage V_{on} has a fixed level of 20V.

[0108] The graphs shown in FIGS. 7-11 are summarized in Table 1 and the result of analysis of Table 1 is illustrated in Table 2.

TABLE 1

Von1	Von2	C _{LC}	V ⁺	V ⁻	V _p ⁺	V _p ⁻	V _k ⁺	V _k ⁻	ΔV _k
20	10	C3	8	0	7.1863	-0.757913	0.8137	0.757913	0.055787
		C2	6.5	1.5	5.5806	0.620486	0.9194	0.879514	0.039886
		C1	5	3	3.9247	1.9419	1.0753	1.0581	0.0172
20	10.8	C3	8	0	7.1906	-0.771301	0.8094	0.771301	0.038099
		C2	6.5	1.5	5.5769	0.603251	0.9231	0.896749	0.026351
		C1	5	3	3.9104	1.921	1.0896	1.079	0.0106

TABLE 1-continued

Von1	Von2	C _{LC}	V ⁺	V ⁻	V _p ⁺	V _p ⁻	V _k ⁺	V _k ⁻	ΔV _k
20	12	C3	8	0	7.1987	-0.794937	0.8013	0.794937	0.0006363
		C2	6.5	1.5	5.5724	0.575174	0.9276	0.924826	0.002774
		C1	5	3	3.8894	1.8903	1.1106	1.1097	0.0009
20	13.2	C3	8	0	7.1921	-0.825383	0.8079	0.825383	-0.01748
		C2	6.5	1.5	5.5557	0.541593	0.9443	0.958407	-0.01411
		C1	5	3	3.8558	1.8477	1.1442	1.1523	-0.0081
20	20	C3	8	0	7.0495	-1.0840	0.9505	1.084	-0.1335
		C2	6.5	1.5	5.3362	0.23795	1.1638	1.26205	-0.09825
		C1	5	3	3.5236	1.4750	1.4764	1.525	-0.0486

[0109]

TABLE 2

Von1	Von2	Max(ΔV _k)	Min(ΔV _k)	Max(ΔV _k) - Min(ΔV _k)
20	10	55.8 mV	17.2 mV	38.6 mV
20	10.8	38.1 mV	10.6 mV	27.5 mV
20	12	6.4 mV	0.9 mV	5.5 mV
20	13.2	-8.1 mV	-17.5 mV	9.4 mV
20	20	-48.6 mV	-133.5 mV	84.9 mV

[0110] In Table 1, V_k⁺ is the kickback voltage under application of the positive gray voltages V⁺, while V_k⁻ is the kickback voltage under application of the negative gray voltages V⁻, and ΔV_k=V_k⁺-V_k⁻. V_p⁺ is the voltage of the pixel electrode under application of the positive gray voltages V⁺, while V_p⁻ is the voltage of the pixel electrode under application of the negative gray voltages V⁻. The unit of the voltages is V, and C1, C2 and C3 are the values of the LC capacitance C_{LC} shown in FIG. 2. That is, C1 and C3 are the values of the LC capacitance C_{LC} at beginning and ending points of a range where the LC capacitance C_{LC} drastically varies, and C2 is an intermediate value between C1 and C3.

[0111] In Table 2, Max(ΔV_k) and Min(ΔV_k) are defined as maximum and minimum values of the kickback voltage difference ΔV_k, respectively.

[0112] Since the gate-on voltage Von shown in FIG. 11 has a fixed value, Table 1 and Table 2 describe the low value Von2 of the gate-on voltage Von to be equal to 20V, which is equal to the high value Von1.

[0113] When the gate-on voltage Von of about 20V maintained constant as shown in FIG. 11, DC voltages of about 134 mV for the LC capacitance C_{LC} of C3, about 98 mV for the LC capacitance C_{LC} of C2, and about 49 mV for the LC capacitance C_{LC} of C1 were remained.

[0114] When the low value Von2 of the gate-on voltage Von was equal to about 10V as shown in FIG. 7, the kickback voltages V_k⁺ and V_k⁻ were much reduced. However, the kickback voltage difference ΔV_k was still large.

[0115] When the low value Von2 of the gate-on voltage Von was equal to about 12V, i.e., a mid-value ((Von1+Vconst)/2) in a range given by Relation 5 as shown in FIG. 9, the kickback voltage difference ΔV_k was lower than 10 mV, which is very small. Accordingly, the remaining DC voltage was much reduced to hardly generate the afterimage.

[0116] The kickback voltage differences ΔV_k for the cases shown in FIGS. 8 and 11 had magnitudes larger than that

shown in FIG. 9, but smaller than those shown in FIGS. 7 and 11. Since the difference (Max(ΔV_k)-Min(ΔV_k)) between the maximum kickback voltage difference Max(ΔV_k) and the minimum kickback voltage difference Min(ΔV_k) was reduced such that the afterimage on a screen as a whole was reduced. In particular, the case shown in FIG. 10 exhibited the kickback voltage difference ΔV_k compared to that shown in FIG. 9.

[0117] Other experiments were performed by setting the high values Von1 of the gate-on voltage Von to be 25V and 35V and the low values Von2 thereof to be 14.5V and 19.5V, which are equal to ((Von1+Vconst)/2). The maximum kickback voltage difference Max(ΔV_k), the minimum kickback voltage difference Min(ΔV_k), and their difference Max(ΔV_k)-Min(ΔV_k) are illustrated in Table 3.

TABLE 3

Von1	Max(ΔV _k)	Min(ΔV _k)	Max(ΔV _k) - Min(ΔV _k)
25 V	4.8 mV	-2.2 mV	7.0 mV
35 V	5.0 mV	2.3 mV	2.7 mV

[0118] In these cases, remaining DC voltages are very small such that the degree of the afterimage is much reduced.

[0119] Other experiments were performed by varying the gate-off voltage Voff with the high values of the gate-on voltage Von as illustrated in Table 3. The maximum kickback voltage difference Max(ΔV_k), the minimum kickback voltage difference Min(ΔV_k), and their difference Max(ΔV_k)-Min(ΔV_k) are illustrated in Table 4.

TABLE 4

Voff	Max(ΔV _k)	Min(ΔV _k)	Max(ΔV _k) - Min(ΔV _k)
-7 V	5.0 mV	-2.3 mV	2.7 mV
-15 V	-5.6 mV	-5.2 mV	0.6 mV

[0120] As shown in Table 4, the change of the gate-off voltage Voff does not affect the reduction of the kickback voltages. Accordingly, the kickback voltage reduction is obtained regardless of the magnitude of the gate-off voltage Voff.

[0121] Although preferred embodiments of the present invention have been described in detail hereinabove, it should be clearly understood that many variations and/or modifications of the basic inventive concepts herein taught

which may appear to those skilled in the present art will still fall within the spirit and scope of the present invention, as defined in the appended claims.

What is claimed is:

1. A liquid crystal display comprising:

a liquid crystal panel including a gate line, a data line, and a pixel including a switching element connected to the gate line and the data line;

a gate driver applying a gate signal for controlling the switching element to the gate line; and

a data driver selecting gray voltages corresponding to gray signals and applying the selected gray voltages to the data line,

wherein the gate signal includes a gate-on voltage for turning on the switching element and a gate-off voltage for turning off the switching element and the gate-on voltage has at least two different levels.

2. The liquid crystal display of claim 1, wherein the gate-on voltage continuously varies for a predetermined time.

3. The liquid crystal display of claim 2, wherein the at least two level includes a first level and a second level lower than the first level and the gate-on voltage continuously decreases from the first level to the second level for the predetermined time.

4. The liquid crystal display of claim 3, wherein

$$\frac{Von1 + Vconst}{2} - \frac{Von1 + Vconst}{2} \times 10\% \leq Von2 \leq \frac{Von1 + Vconst}{2} + \frac{Von1 + Vconst}{2} \times 10\%,$$

where Von1 and Von2 indicate the first and the second levels, respectively, and Vconst indicates a predetermined voltage level.

5. The liquid crystal display of claim 4, wherein the gray voltages include a plurality of pairs of a positive voltage (V^+) and a negative voltage (V^-) assigned to each gray and

$$\frac{V^+ + V^-}{2} = Vconst$$

for each gray.

6. The liquid crystal display of claim 5, wherein the continuous decrease of the gate-on voltage from the first level to the second level is linear.

7. The liquid crystal display of claim 5, wherein the continuous decrease of the gate-on voltage from the first level to the second level is performed around a time when the gate signal moves from the gate-on voltage to the gate-off voltage.

8. The liquid crystal display of claim 7, wherein the gate-on voltage reaches the second level at a time when the gate signal moves from the gate-on voltage to the gate-off voltage.

9. The liquid crystal display of claim 1, further comprising a voltage generator including:

a first switch selectively transmitting a first voltage;

a first capacitor connected to the first switch and charging a voltage from the first switch; and

a second switch connected to the first capacitor and forming a discharging path of the voltage charged in the first capacitor.

10. The liquid crystal display of claim 9, wherein the voltage generator further comprises a resistor connected between the second switch and the first capacitor and the first switch discharges according to a time constant determined by a resistance of the resistor and a capacitance of the capacitor.

11. The liquid crystal display of claim 9, wherein the voltage generator further comprises:

a signal generator for generating a pulse signal with a predetermined period;

a voltage divider dividing the first voltage; and

a second capacitor for charging a voltage from the voltage divider for turning on and turning off the first switch responsive to the pulse signal from the signal generator,

wherein the first switch and the second switch are alternately activated based on the pulse signal from the signal generator.

12. The liquid crystal display of claim 11, wherein the first switch comprises a PNP bipolar transistor and the second switch comprises an NPN bipolar transistor.

13. The liquid crystal display of claim 12, wherein the signal generator is connected to a base of the PNP bipolar transistor and is connected to a base of the NPN bipolar transistor via the first capacitor.

14. The liquid crystal display of claim 12, wherein the voltage divider comprises a first resistor and a second resistor connected in series between the first voltage and a ground and is connected to a base of the PNP generator, and

$$\frac{Vbe2}{Vn} \leq \frac{1}{1 + (R2/R1)} < \frac{Vbe2 + (Vhigh - Vlow)}{Vn},$$

where R1 and R2 are resistances of the first and the second resistors, respectively, Vbe2 is a base-emitter voltage of the PNP transistor, Vn is a value of the first voltage, and Vhigh and Vlow are high and low levels of the pulse signal of the signal controller, respectively.

15. A method of driving a liquid crystal display including a plurality of gate lines, a plurality of data lines, and a plurality of pixels including switching elements connected to the gate lines and the data lines, the method comprising:

generating a plurality of pairs of a positive gray voltage (V^+) and a negative gray voltage (V^-) for respective grays satisfying

$$\frac{V^+ + V^-}{2} = Vconst,$$

where Vconst is a predetermined value;

generating a gate signal including a gate-on voltage for turning on the switching element and a gate-off voltage for turning off the switching element;

applying the gate signal to the gate lines; and

applying the gray signals to the data lines,

wherein the gate-on voltage decreases from a first level (Von1) to a second level (Von2) for a predetermined time and

$$\frac{Von1 + Vconst}{2} - \frac{Von1 + Vconst}{2} \times 10\% \leq$$

$$Von2 \leq \frac{Von1 + Vconst}{2} + \frac{Von1 + Vconst}{2} \times 10\%.$$

* * * * *

专利名称(译)	液晶显示器及其驱动方法		
公开(公告)号	US20040246219A1	公开(公告)日	2004-12-09
申请号	US10/664075	申请日	2003-09-17
[标]申请(专利权)人(译)	MOON SEUNG HWAN		
申请(专利权)人(译)	MOON SEUNG-HWAN		
当前申请(专利权)人(译)	三星DISPLAY CO. , LTD.		
[标]发明人	MOON SEUNG HWAN		
发明人	MOON, SEUNG-HWAN		
IPC分类号	G02F1/133 G09G3/20 G09G3/36		
CPC分类号	G09G3/3648 G09G3/3677 G09G2320/0257 G09G2320/0219 G09G3/3696		
优先权	1020020056508 2002-09-17 KR		
其他公开文献	US7199777		
外部链接	Espacenet USPTO		

摘要(译)

提供一种液晶显示器，包括：液晶面板，包括栅极线，数据线和像素，所述像素包括连接到栅极线和数据线的开关元件；栅极驱动器，将栅极信号用于控制开关元件到栅极线；数据驱动器选择对应于灰度信号的灰度电压，并将所选择的灰度电压施加到数据线。栅极信号包括用于导通开关元件的栅极导通电压和用于关断开关元件的栅极截止电压。灰度电压包括正负电压对 ($V+$, $V-$) 和 $1V$ 及 MO ; $+ </math; $MO >$; $</math; $MSUP >$; $<MO >$; $+ </math; $MO >$; $<MSUP >$; $<MI >$; $V </math; $MI >$; $<MO >$; $- </math; $MO >$; $<MSUP >$; $<MROW >$; $<MN >$; $2 </math; $MN >$; $<MFRAC >$; $<MO >$; $= </math; $MO >$; $<MI >$; $V_{const} </math; $MI >$; $<MROW >$; $<MATH >$; $<$;$$$$$$$$

mathematica-file id = "MATHEMATICA-00001"file = "US20040246219A1-20041209-M00001.NB"/> < <image id = "EMI-M00001"wi = "216.027"he = "18.00225"file = "US20040246219A1-20041209-M00001.TIF"imf = "TIFF"ti = "MF"/> < < / MATH-CWU>对

于每个灰色，其中 V_{const} 表示预定级别。栅极导通电压从第一电平持续降低到第二电平达预定时间，并且第一电平 (V_{on1}) 和第二电平 (V_{on2}) 满足由 $<math-cwu id = "MATH-US" >$ 给出的关系。 $-00002 >$; $<NUMBER >$; $2 </math; $NUMBER >$; $<$; $MATH >$; $<MROW >$; $<MROW >$; $<MFRAC >$; $<MROW >$; $<MI >$; $V_{on1} </math; $MI >$; $<MO >$; $+ </math; $MO >$; $<MI >$; $V_{const} </math; $MI >$; $<MROW >$; $<MN >$; $2 </math; $MN >$; $- V_{on1} + V_{const} 2 \times 10 \% \leq V_{on2} \leq V_{on1} + V_{const} 2 + V_{on1} + V_{const} 2 \times 10 \% .$$$$$$

