



US 20110128475A1

(19) **United States**

(12) **Patent Application Publication**  
**PARK et al.**

(10) **Pub. No.: US 2011/0128475 A1**  
(43) **Pub. Date: Jun. 2, 2011**

(54) **LIQUID CRYSTAL DISPLAY MODULE**

(52) **U.S. Cl. .... 349/96**

(76) **Inventors: Jong Sin PARK, Seoul (KR); Eung Do Kim, Paju-si (KR); Se Hong Park, Goyang-si (KR); Kyung Ha Lee, Haman-gun (KR)**

(57) **ABSTRACT**

Disclosed is a liquid crystal display module that improves luminance of a liquid crystal panel by enhancing a light transmittance. The liquid crystal display module comprises a liquid crystal panel with plural unit pixels for converting incident light into colored light, wherein each unit pixel includes red (R), green (G), blue (B), and white (W) sub-pixels; a light source for supplying light to the liquid crystal panel; an optical member for guiding light emitted from the light source toward a frontal direction of the liquid crystal panel; and a polarizing means including a polarization area for polarizing the light outgoing from the liquid crystal panel, and a hole for transmitting the light therethrough.

(21) **Appl. No.: 12/878,600**

(22) **Filed: Sep. 9, 2010**

(30) **Foreign Application Priority Data**

Dec. 2, 2009 (KR) ..... 10-2009-0118440

**Publication Classification**

(51) **Int. Cl. G02F 1/1335 (2006.01)**

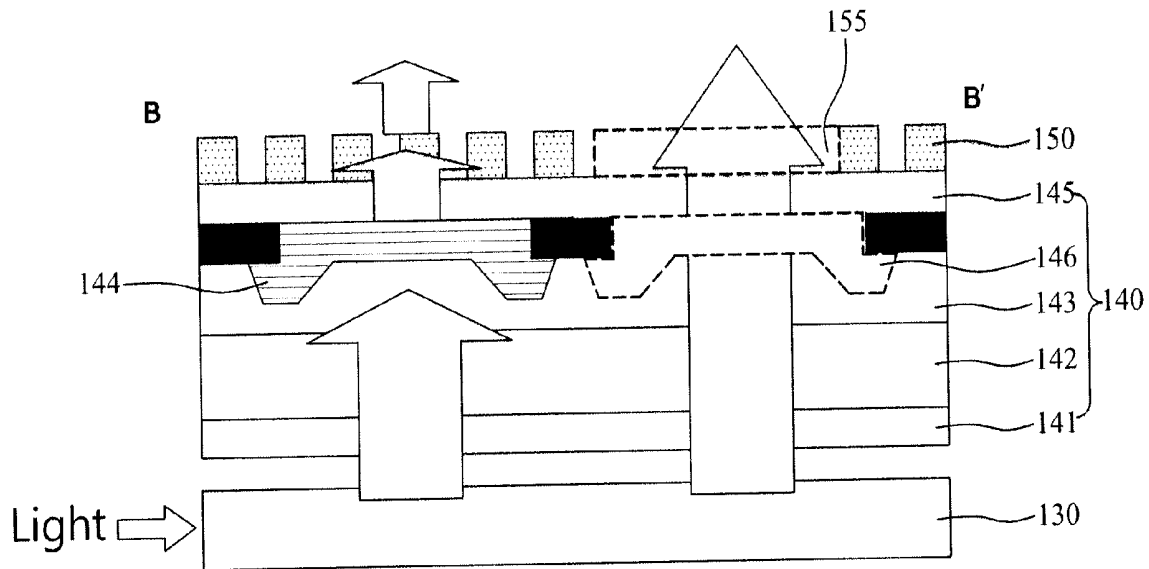

[RELATED ART]

FIG.1

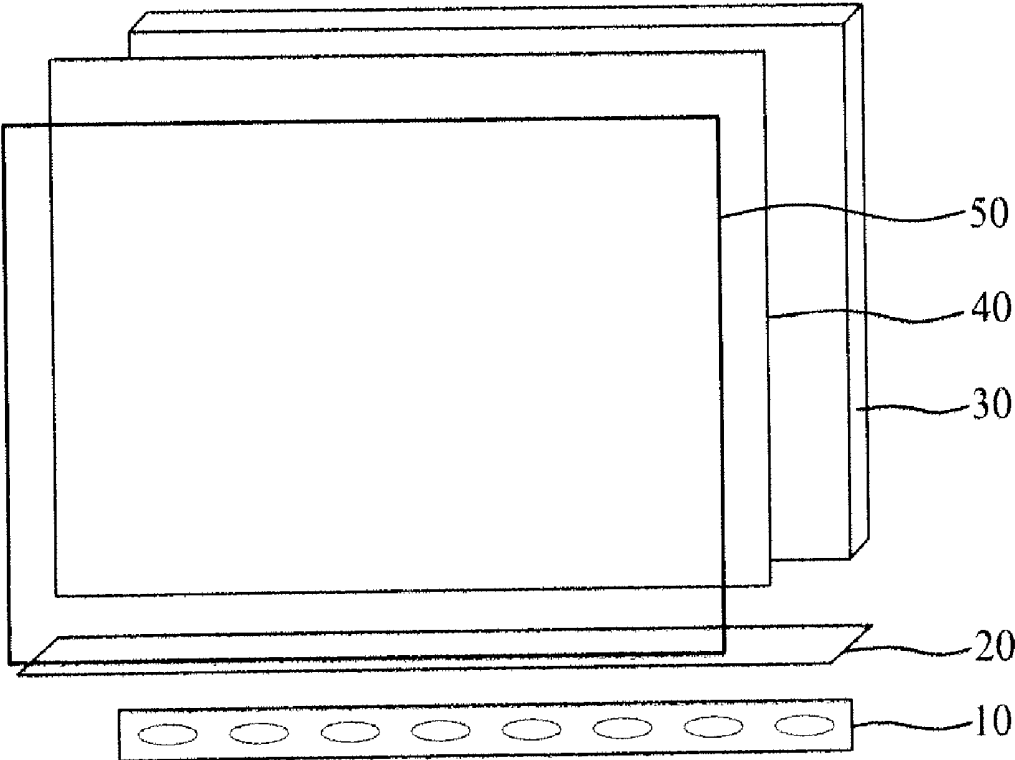

[RELATED ART]

FIG.2

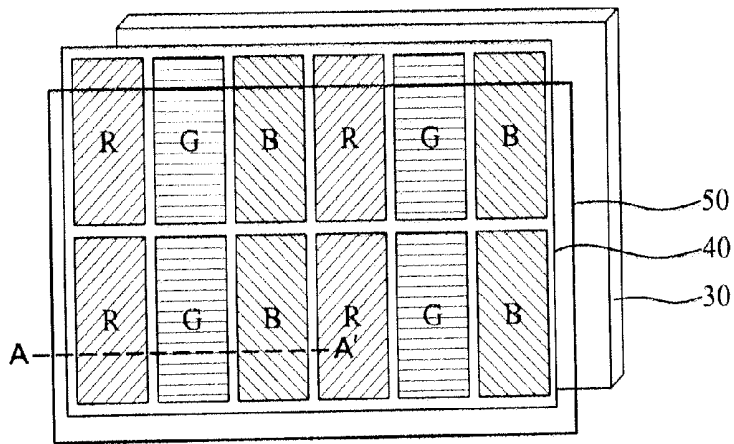

[RELATED ART]

FIG.3

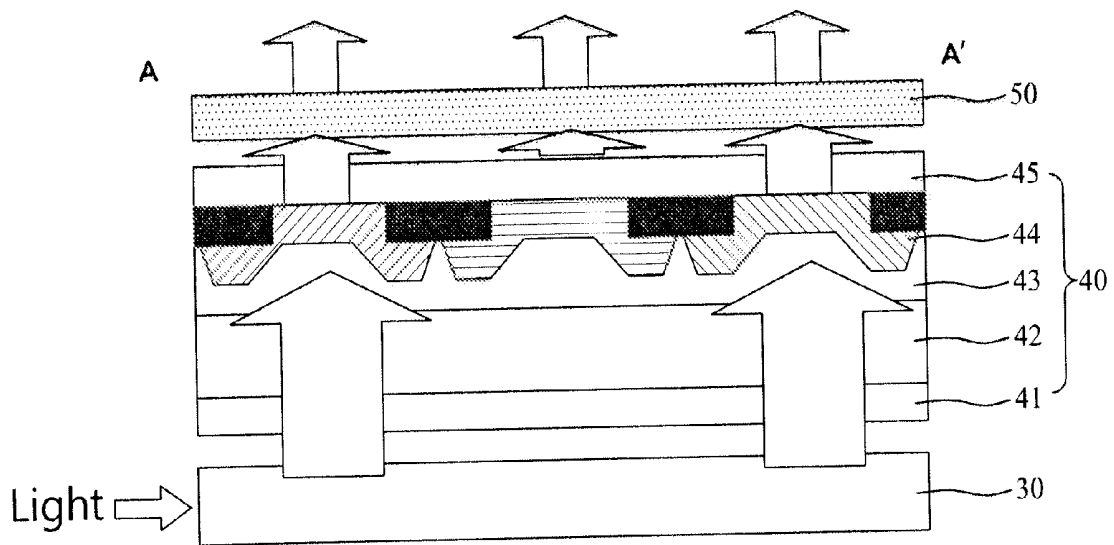

FIG.4

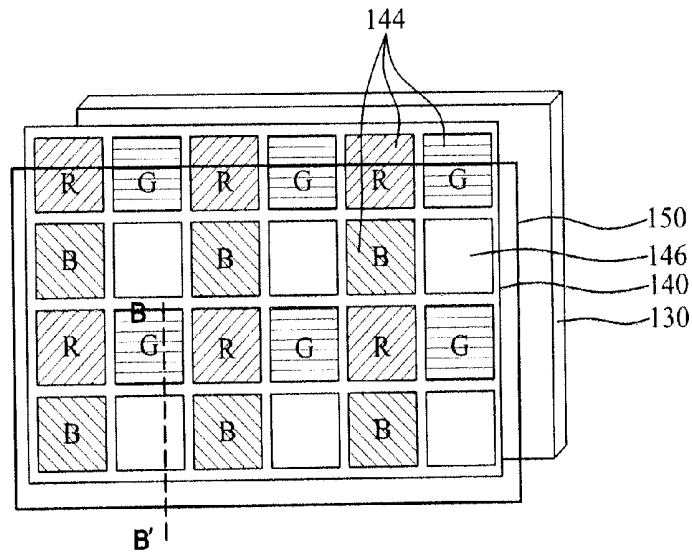

FIG.5

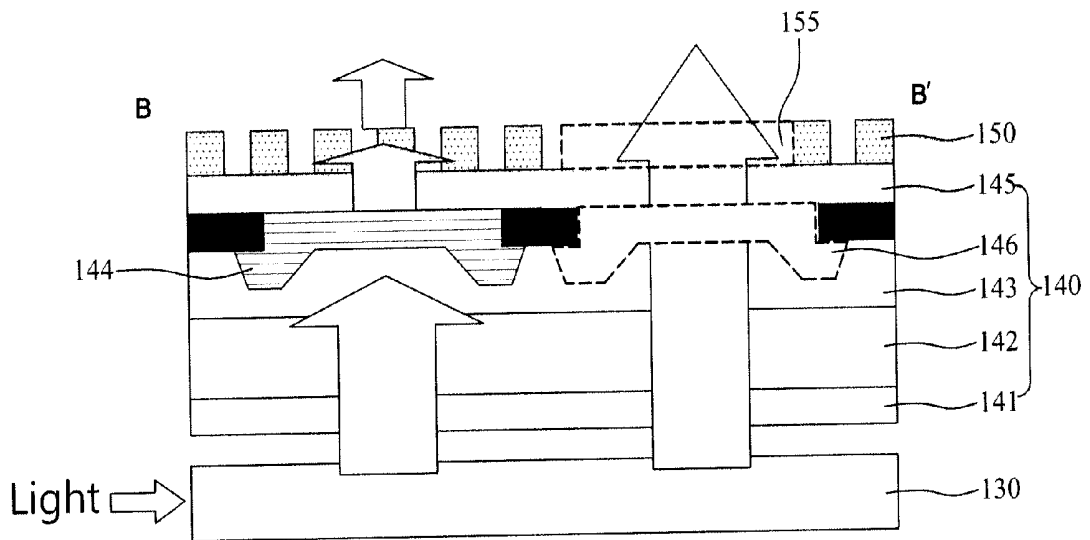

FIG.6

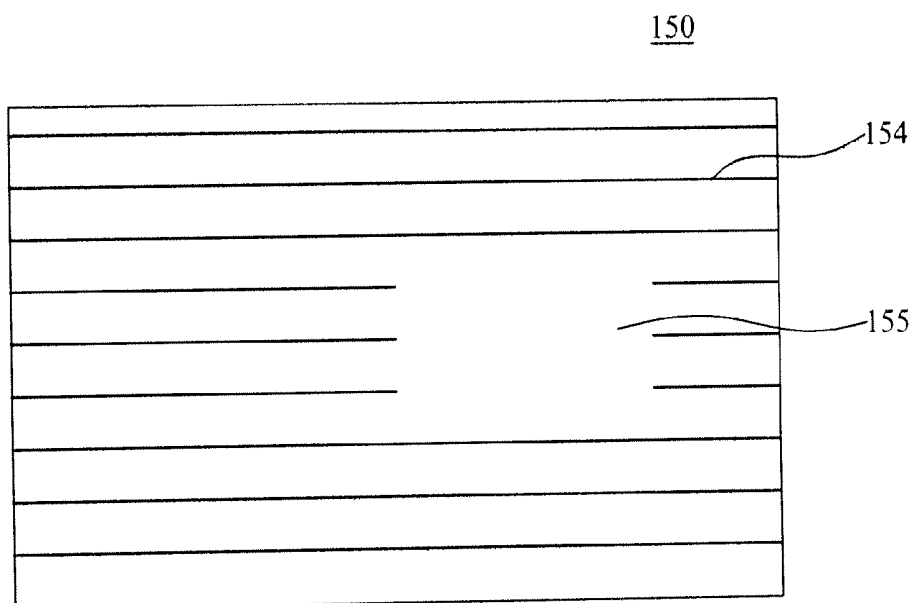

FIG.7

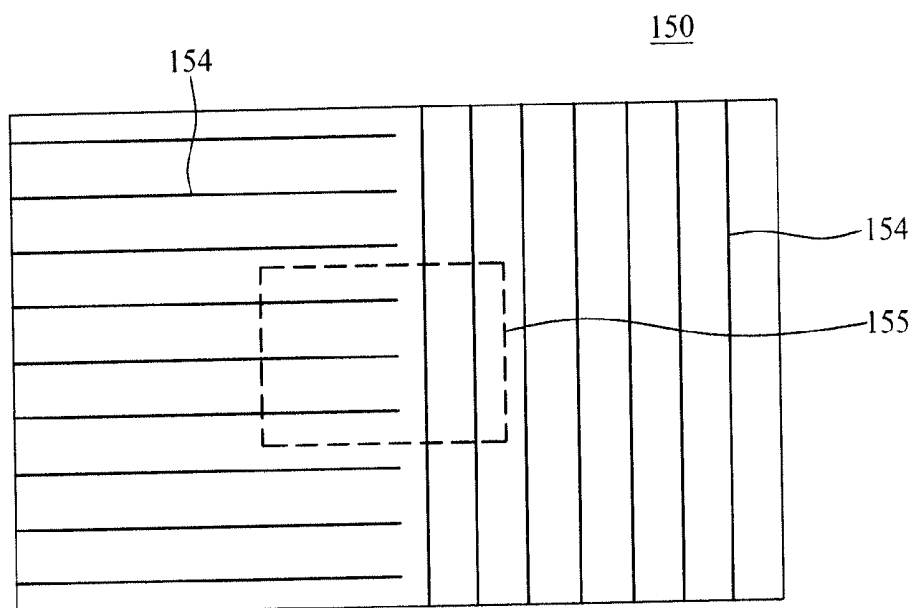

FIG.8

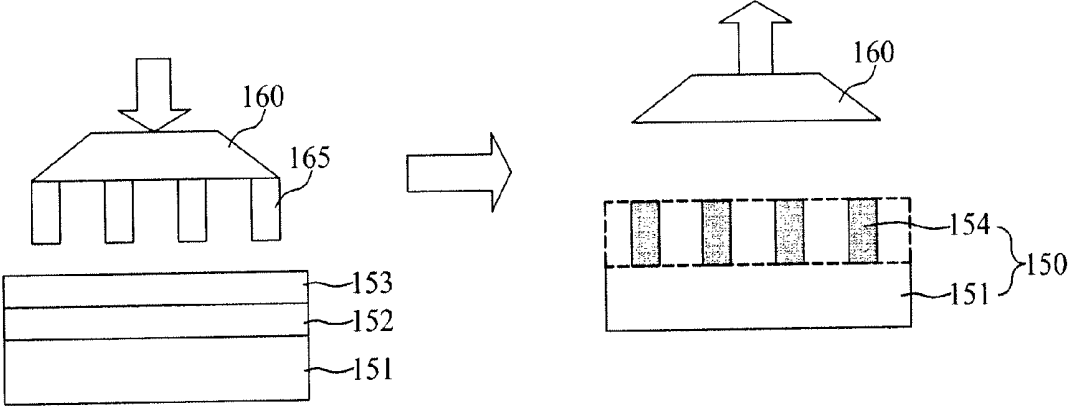

FIG.9

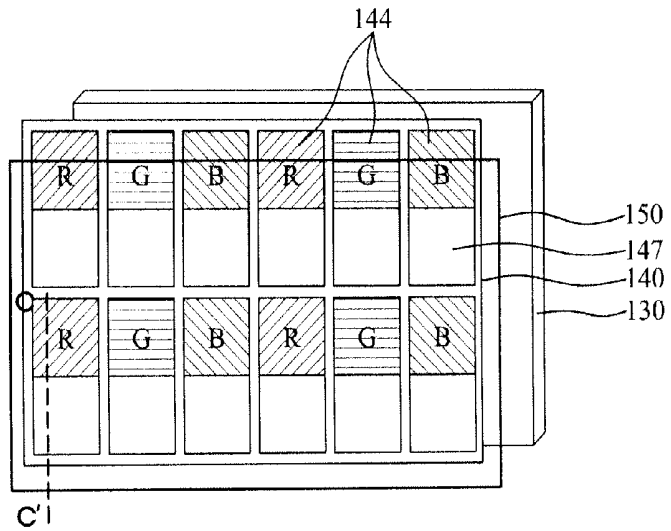
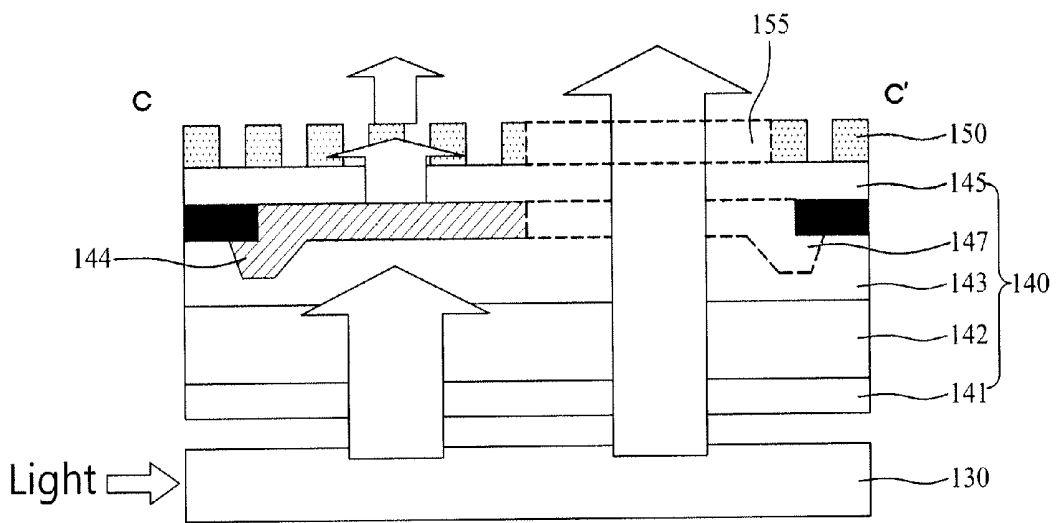

FIG.10



## LIQUID CRYSTAL DISPLAY MODULE

### CROSS REFERENCE TO RELATED APPLICATIONS

[0001] This application claims the benefit of the Korean Patent Application No. 10-2009-0118440 filed on Dec. 2, 2009, which is hereby incorporated by reference as if fully set forth herein.

### BACKGROUND OF THE INVENTION

[0002] 1. Field of the Invention

[0003] The present invention relates to a liquid crystal display module, and more particularly, to a liquid crystal display module capable of improving luminance of a liquid crystal panel by enhancing a light transmittance.

[0004] 2. Discussion of the Related Art

[0005] An application field of liquid crystal display device (hereinafter, referred to as 'LCD device') has been gradually expanded owing to various advantages such as lightness in weight, thin profile, and low-driving power. In recent years, the LCD device is widely used for office automation devices, multimedia devices, and information communication devices.

[0006] A liquid crystal display module of the LCD device includes a liquid crystal panel which is provided with liquid crystal cells arranged in a matrix-type configuration between two glass substrates; and a backlight unit for supplying light to the liquid crystal panel.

[0007] The liquid crystal panel displays images by controlling a light transmittance according to a video signal applied to control switches such as thin film transistors (TFT) arranged in a matrix-type configuration. At this time, the liquid crystal panel cannot emit light in itself. Thus, the liquid crystal panel is supplied with the light emitted from the backlight unit including a light source, wherein the light source included in the backlight unit may be positioned at a rear side or lateral side of the liquid crystal panel.

[0008] The backlight unit can be classified into a direct type and an edge type according to the position of the light source. In more detail, the direct type backlight unit includes the light source positioned at the rear side of the liquid crystal panel; and the edge type backlight unit includes the light source positioned at the lateral side of the liquid crystal panel.

[0009] FIGS. 1 and 2 illustrate a related art liquid crystal display module. FIG. 3 is a cross section view along A-A' of FIG. 2. FIGS. 1 and 2 show an edge-type backlight unit using a light-emitting diode (LED) as a light source.

[0010] Referring to FIGS. 1 to 3, the related art liquid crystal display module includes a liquid crystal panel 40 for displaying images by controlling a light transmittance of liquid crystal according to input video data; a light source 10 for supplying light to the liquid crystal panel 40; a lower polarizing plate 20 for polarizing the light emitted from the light source 10; a light-guiding plate 30 for guiding the light incident on its lateral side to a frontal direction of the liquid crystal panel 40; and an upper polarizing plate 50, positioned above the liquid crystal panel 40, for polarizing the light outgoing from the liquid crystal panel 40.

[0011] The liquid crystal panel 40 includes a lower glass substrate 41 on which control switches such as thin film transistors (TFT) are formed; an upper glass substrate 45 on which a color filter layer 44 is formed; a spacer (not shown) for maintaining a constant cell gap between the lower and

upper glass substrates 41 and 45; a liquid crystal 42 filled in a space prepared by the spacer; and an over-coating layer 43 formed between the liquid crystal 42 and the color filter layer 44.

[0012] The liquid crystal panel 40 cannot emit the light in itself. Thus, the liquid crystal panel 40 displays the images by controlling the transmittance of light emitted from the light source 10. One of the most important points to be duly considered for improvement of the picture quality of the images displayed in the liquid crystal panel 40 is luminance of the light irradiated on the liquid crystal panel 40. That is, the light with high luminance has to be supplied to the liquid crystal panel 40, to thereby obtain the high picture quality in the displayed images.

[0013] In the related art liquid crystal display module having the aforementioned structure, the light emitted from the light source 10 comes out from the liquid crystal display module after traveling through the lower polarizing plate 20, the light-guiding plate 30, the liquid crystal panel 40, and the upper polarizing plate 50, whereby the luminance of light finally outgoing from the liquid crystal panel 40 is lowered considerably.

[0014] If the liquid crystal panel 40 has 13.3-inch (113 pixels per inch) size, the light transmittance of each of the lower and upper polarizing plates 20 and 50 is 45%; the light transmittance of each of the lower and upper glass substrates 41 and 45 is 94%; the light transmittance of TFT array and pixel on the lower glass substrate 41 of the liquid crystal panel 40 is 65%; and the light transmittance of color filter layer 44 of the liquid crystal panel 40 is 27%.

[0015] Eventually, the light outgoing from the liquid crystal panel 40 is only about 7~8% of the light emitted from the light source 10, whereby the light transmittance becomes low. Meanwhile, if the liquid crystal panel 40 has 32-inch (49 pixels per inch) size, the light outgoing from the liquid crystal panel 40 is about 5% of the light emitted from the light source 10, whereby the light transmittance becomes considerably lowered.

[0016] The related art liquid crystal display module is disadvantageous in that most of light emitted from the light source 10 is lost by passing through the lower polarizing plate 20, the upper polarizing plate 50, and the color filter layer 44, included in the liquid crystal panel 40, having the aforementioned light transmittances. Thus, the light efficiency of the related art liquid crystal display module is lowered by the light loss.

[0017] In order to overcome this problem, the plural light sources 10 may be additionally arranged in the backlight unit, to thereby improve the luminance of the liquid crystal display module. However, a manufacturing cost of the liquid crystal display module is increased due to the additionally-provided light sources 10. Also, if additionally driving the plural light sources 10, power consumption is highly increased.

### SUMMARY OF THE INVENTION

[0018] Accordingly, the present invention is directed to a liquid crystal display module that substantially obviates one or more problems due to limitations and disadvantages of the related art.

[0019] An advantage of the present invention is to provide a liquid crystal display module which facilitates to improve light transmittance by enhancing transparency.

[0020] Another advantage of the present invention is to provide a liquid crystal display module which facilitates to improve luminance of liquid crystal panel.

[0021] Another advantage of the present invention is to provide a liquid crystal display module which facilitates to reduce a manufacturing cost.

[0022] A further advantage of the present invention is to provide a liquid crystal display module which facilitates to lower power consumption used for its driving mode.

[0023] Additional advantages and features of the invention will be set forth in part in the description which follows and in part will become apparent to those having ordinary skill in the art upon examination of the following or may be learned from practice of the invention. The objectives and other advantages of the invention may be realized and attained by the structure particularly pointed out in the written description and claims hereof as well as the appended drawings.

[0024] To achieve these and other advantages and in accordance with the purpose of the invention, as embodied and broadly described herein, there is provided a liquid crystal display module comprising: a liquid crystal panel with plural unit pixels, wherein each unit pixel includes red (R), green (G), blue (B), and white (W) sub-pixels, for converting incident light into colored light; a light source for supplying light to the liquid crystal panel; an optical member for guiding light emitted from the light source toward a frontal direction of the liquid crystal panel; and a polarizing means including a polarization area for polarizing the light outgoing from the liquid crystal panel, and a hole for transmitting the light there-through.

[0025] At this time, the polarizing means is formed of a wire grid polarizer (WGP) including a nano-sized grid pattern with metal conductor lines arranged at a predetermined pitch.

[0026] Also, the hole of the polarizing means is formed in an area corresponding to at least one of the red (R), green (G), blue (B), and white (W) sub-pixels.

[0027] In another aspect of the present invention, there is provided a liquid crystal display module comprising: a liquid crystal panel with plural unit pixels, wherein each unit pixel includes red (R), green (G), and blue (B) sub-pixels, for converting incident light into colored light; a light source for supplying light to the liquid crystal panel; an optical member for guiding light emitted from the light source toward a frontal direction of the liquid crystal panel; and a polarizing means including a polarization area for polarizing the light outgoing from the liquid crystal panel, and a hole for transmitting the light therethrough.

[0028] Each of the red (R), green (G), and blue (B) color filter layers includes a hole to transmit the light therethrough.

[0029] The hole of the polarizing means is positioned in an area corresponding to the hole of the color filter layer.

[0030] It is to be understood that both the foregoing general description and the following detailed description of the present invention are exemplary and explanatory and are intended to provide further explanation of the invention as claimed.

#### BRIEF DESCRIPTION OF THE DRAWINGS

[0031] The accompanying drawings, which are included to provide a further understanding of the invention and are incorporated in and constitute a part of this application, illustrate embodiment(s) of the invention and together with the description serve to explain the principle of the invention. In the drawings:

[0032] FIGS. 1 and 2 illustrate a related art liquid crystal display module;

[0033] FIG. 3 is a cross section view along A-A' of FIG. 2;

[0034] FIG. 4 illustrates a liquid crystal display module according to the first embodiment of the present invention;

[0035] FIG. 5 is a cross section view along B-B' of FIG. 4;

[0036] FIG. 6 illustrates one type of wire grid polarizer (WGP) in the liquid crystal display module shown in FIG. 4;

[0037] FIG. 7 illustrates another type of wire grid polarizer (WGP) in the liquid crystal display module shown in FIG. 4;

[0038] FIG. 8 illustrates a method for manufacturing a wire grid polarizer (WGP);

[0039] FIG. 9 illustrates a liquid crystal display module according to the second embodiment of the present invention; and

[0040] FIG. 10 is a cross section view along C-C' of FIG. 9.

#### DETAILED DESCRIPTION OF THE INVENTION

[0041] Reference will now be made in detail to the exemplary embodiments of the present invention, examples of which are illustrated in the accompanying drawings. Wherever possible, the same reference numbers will be used throughout the drawings to refer to the same or like parts.

[0042] Hereinafter, a liquid crystal display module according to the present invention will be described with reference to the accompanying drawings.

[0043] FIG. 4 illustrates a liquid crystal display module according to the first embodiment of the present invention. FIG. 5 is a cross section view along B-B' of FIG. 4. FIGS. 4 and 5 illustrate an edge-type backlight unit which uses an LED as a light source.

[0044] Hereinafter, a liquid crystal display module according to the first embodiment of the present invention will be described with reference to FIGS. 4 and 5.

[0045] Referring to FIGS. 4 and 5, the liquid crystal display module according to the first embodiment of the present invention includes a liquid crystal panel 140 for displaying images by controlling a light transmittance of liquid crystal according to input video data; a light source (not shown) for supplying light to the liquid crystal panel 140; a light-guiding plate 130 for guiding light incident on its lateral side to a frontal direction of the liquid crystal panel 140; and a wire grid polarizer 150 (hereinafter, referred to as 'WGP') for polarizing the light outgoing from the liquid crystal panel 140, the WGP 150 positioned above the liquid crystal panel 140. Although not shown, there may be a lower polarizing plate (not shown) for polarizing the light emitted from the light source (not shown).

[0046] The liquid crystal panel 140 includes a lower glass substrate 141, an upper glass substrate 145, spacers (not shown), a liquid crystal layer 142, color filter layers 144 and 146, and an over-coating layer 143. In this case, switching devices such as thin film transistors (TFT) are formed on the lower glass substrate 141; and the color filter layers 144 and 146 are formed on the upper glass substrate 145. Also, the spacers (not shown) are provided between the lower and upper glass substrates 141 and 145, to thereby maintain a cell gap therebetween. The liquid crystal layer 142 is filled in a space prepared by the spacers. Owing to the color filter layers 144 and 146 on the upper glass substrate 145, the light passing through the liquid crystal layer 142 has its own peculiar color of red (R), green (G), blue (B), or white (W) color. The over-coating layer 143 on the liquid crystal layer 142 prevents

the color filter layers **144** and **146** from being damaged, and simultaneously enables a planar surface in pixels.

[0047] In the liquid crystal panel **140**, each pixel region is defined by gate and data lines (not shown) crossing each other at right angles. On the pixel region, a pixel electrode is arranged in parallel to the data line, wherein the pixel electrode is formed of a transparent metal material such as ITO (Indium-Tin-Oxide). Also, the switching device such as the TFT is formed in a region corresponding to a crossing portion of the gate and data lines. When the TFT is turned-on by a driving signal applied to the gate line, a data signal applied to the data line is applied to the pixel electrode through a channel layer of the TFT.

[0048] The color filter layers **144** and **146** include red (R), green (G), and blue (B) color filter layers **144**; and white color filter layers **146**, wherein a black matrix is provided between each of the respective color filter layers **144** and **146**.

[0049] Each of the red (R), green (G), and blue (B) color filter layers **144** is formed through the use of photoresist (PR) having its own peculiar color; and the white color filter **146** is formed of transparent photoresist.

[0050] For example, the white color filter layer **146** may be formed in a column-spacer forming method using the transparent photoresist, or may be formed in an over-coating method using the transparent photoresist.

[0051] In the liquid crystal display module according to the first embodiment of the present invention, the four pixel electrodes, that is, four sub-pixels constitute one unit pixel. On the upper glass substrate **145**, the red (R), green (G), and blue (B) color filter layers **144**, and the white (W) color filter layers **146** are arranged in a matrix-type configuration, which are provided to confront the pixel electrodes of the lower glass substrate **141**. In the liquid crystal panel **140** of the liquid crystal display module according to the first embodiment of the present invention, four sub-pixels of the red (R), green (G), blue (B), and white (W) sub-pixels constitute one unit pixel.

[0052] Accordingly, the color filter layers **144** and **146** of the liquid crystal display module according to the first embodiment of the present invention include the white (W) color filter layers **146** as well as the red (R), green (G), and blue (B) color filter layers **144**. As the white (W) sub-pixel is additionally provided together with the red (R), green (G), and blue (B) sub-pixels, a light transmittance per unit pixel can be enhanced. Thus, the light with high luminance, outgoing from the liquid crystal panel **140**, enables to improve the picture quality.

[0053] The WGP **150** is provided on the aforementioned liquid crystal panel **140**, wherein the WGP **150** checks horizontally-polarized and vertically-polarized components of the incident light; and selectively transmits or blocks the vertically-polarized or horizontally-polarized component. In this respect, the WGP **150** functions as a general polarizing plate (polarizing film).

[0054] Among the vertical or horizontal light emitted from the backlight unit, the WGP **150** transmits only light vibrated in the same direction as a polarizing axis; and absorbs or reflects the other types of light, to thereby generate the polarization in a particular direction.

[0055] As shown in FIG. 6, the WGP **150** includes a nano-sized grid pattern **154** with conductor lines arranged at a predetermined pitch, wherein the conductor lines are formed of metal. At this time, the grid pattern **154** has the pitch (for example, not more than a half wavelength of visible rays)

which is smaller than that of the incident light (for example, visible rays having 400–800 nm wavelength).

[0056] Thus, the WGP **150** transmits only one type of the polarized components (P-wave or S-wave) among the light emitted from the backlight unit and passing through the liquid crystal panel **140**; and reflects the other type of the polarized components toward the liquid crystal panel **140**. That is, the WGP **150** functions as a polarizing plate which generates a single polarization.

[0057] The related art polarizing plate absorbs some of the non-transmitted polarized components from the incident light, whereby the light loss occurs. However, the WGP **150** of the present invention reflects the non-transmitted polarized components, whereby the light loss is relatively reduced, and the luminance of light outgoing from the liquid crystal panel **140** is increased.

[0058] At this time, the WGP **150** includes a polarization area with the grid pattern **154** for polarizing the incident light; and a hole **155** for transmitting the light therethrough. The hole **155** is formed in an area corresponding to any one of the red (R), green (G), blue (B), and white (W) sub-pixels included in the unit pixel. In FIGS. 4 and 5, the hole **155** is formed in the area corresponding to the white (W) sub-pixel, that is, the hole **155** of the WGP **150** is positioned in the area corresponding to the white color filter layer **146**.

[0059] In the aforementioned explanation, the hole **155** of the WGP **150** is provided in the area corresponding to any one of the red (R), green (G), blue (B), and white (W) sub-pixels constituting the unit pixel. However, a modified exemplary case of the present invention may disclose that the plural holes **155** may be respectively provided in the areas corresponding to the plural sub-pixels.

[0060] According to another exemplary case of the present invention, the hole **155** may be provided for every unit pixel, or may be provided every predetermined number of the unit pixels. Also, the holes **155** may be respectively formed in the different color filter layers of the neighboring unit pixels.

[0061] FIG. 6 discloses that the WGP **150** includes one polarizing axis, and the hole **155** for transmitting the light therethrough. However, as shown in FIG. 7, the WGP **150** may the plural polarizing axes, and the hole **155** for transmitting the light therethrough.

[0062] FIG. 8 illustrates a method for manufacturing the WGP **150** shown in FIG. 6.

[0063] Referring to FIG. 8, a metal thin film **152** is deposited on a base film **151** (or glass substrate), and the metal thin film **152** is coated with polymer **153**.

[0064] Then, a mold **165** with a grid pattern is positioned above the metal thin film **152** and polymer **153**; and is pressed down through the use of press **160**, whereby the grid pattern of the mold **165** is printed on the polymer **153**. When manufacturing the mold **165**, a hole pattern may be formed together with the grid pattern of the mold **165**, so that it is possible to form the WGP **150** having both the grid pattern **154** and hole **155**.

[0065] The hole **155** of the WGP **150** is positioned in the area corresponding to the at least one of the red (R), green (G), blue (B), and white (W) sub-pixels constituting one unit pixel, and more preferably, the white color filter layer **146**.

[0066] After the mold **165** is positioned in parallel to the polymer **153**, heat or ultraviolet ray (UV) is applied to the mold **165**, whereby the polymer **153** is cured to have the grid pattern.

[0067] Then, the mold 165 is separated from the polymer 153, whereby the pattern of the mold 165 is printed on the polymer 153, to thereby form the grid pattern whose relieve and intaglio are opposite to those of the mold 165.

[0068] After separating the mold 165 from the polymer 153, the pattern formed in the polymer 153 is etched to expose the surface of the metal thin film 152. After completing the etching process, the etched polymer 153 is removed, and the surface of the metal thin film 152 is exposed.

[0069] Then, the metal thin film 152 whose surface is exposed is etched by a drying-etching method or wet-etching method, to thereby form the grid pattern 154. After that, the remaining polymer 153 is removed from the grid pattern 154, whereby the WGP 150 is completed, wherein the WGP 150 includes the grid pattern 154 for polarizing the incident light, and the hole 155 for transmitting the incident light.

[0070] In the aforementioned explanation, the WGP 150 is formed of an additional film. However, another exemplary case of the present invention may disclose that the grid pattern may be formed on the upper glass substrate 145.

[0071] In the aforementioned explanation, the grid pattern 154 of the WGP 150 is formed in the pressing method using the press. Another exemplary case of the present invention may form the grid pattern 154 of the WGP 150 in a nanoimprint lithography using a roller, that is, R2RNIL (roll-to-roll nanoimprint lithography).

[0072] As mentioned above, when the hole 155 of the WGP 150 is provided in the area corresponding to at least one of the red (R), green (G), blue (B), and white (W) sub-pixels constituting the unit pixel, and more preferably, the white color filter layer 146; the light passing through the white color filter layer 146 is transmitted without being reflected on the WGP 150. Thus, the light outgoing from the liquid crystal panel 140 is not lost while passing through the WGP 150, to thereby improve light efficiency.

[0073] Referring to the following table 1, on assumption that the liquid crystal panel has 13.3-inch size, while the light transmittance of the liquid crystal display module according to the related art is 7.86%, the light transmittance of the liquid crystal display module according to the present invention is 10.74%, whereby the light transmittance of the liquid crystal display module according to the present invention is increased by 36%, as compared to the light transmittance of the liquid crystal display module according to the related art. On assumption that the liquid crystal panel has 32.0-inch size, while the light transmittance of the liquid crystal display module according to the related art is 5.11%, the light transmittance of the liquid crystal display module according to the present invention is 8.69%, whereby the light transmittance of the liquid crystal display module according to the present invention is increased by 70%, as compared to the light transmittance of the liquid crystal display module according to the related art.

TABLE 1

Size of liquid crystal panel	Light transmittance of the related art	Light transmittance of the present invention	Increase of light transmittance
13.3"	7.86%	10.74%	Increased by 36%
32.0"	5.11%	8.69%	Increased by 70%

[0074] In the liquid crystal display module according to the related art, the light passes through the upper polarizing plate

and the color filter layers, whereby the light loss occurs by the respective light transmittances. In the liquid crystal display module according to the present invention, the unit pixel is provided with the sub-pixels including one white (W) sub-pixel with high light transmittance. Also, the hole 155 of the WGP 150 is provided in the area corresponding to the at least one among the four sub-pixels included in the unit pixel. Thus, the light transmittance of the present invention can be considerably improved in comparison to the light transmittance of the related art.

[0075] FIG. 9 illustrates a liquid crystal display module according to the second embodiment of the present invention. FIG. 10 is a cross section view along C-C' of FIG. 9. FIGS. 9 and 10 illustrate an edge-type backlight unit which uses an LED as a light source.

[0076] Hereinafter, a liquid crystal display module according to the second embodiment of the present invention will be described with reference to FIGS. 9 and 10. Except a color filter layer 144 and WGP 150 of a liquid crystal panel 140, the liquid crystal display module according to the second embodiment of the present invention is identical in structure to the liquid crystal display module according to the first embodiment of the present invention, whereby a detail explanation for the same parts will be omitted.

[0077] Referring to FIGS. 9 and 10, the liquid crystal display module according to the second embodiment of the present invention includes a liquid crystal panel 140 for displaying images by controlling a light transmittance of liquid crystal according to input video data; a light source (not shown) for supplying light to the liquid crystal panel 140; a light-guiding plate 130 for guiding light incident on its lateral side to a frontal direction of the liquid crystal panel 140; and a WGP 150 for polarizing the light outgoing from the liquid crystal panel 140, the WGP 150 positioned above the liquid crystal panel 140. Although not shown, there may be a lower polarizing plate (not shown) for polarizing the light emitted from the light source.

[0078] The liquid crystal panel 140 includes a lower glass substrate 141, an upper glass substrate 145, spacers (not shown), a liquid crystal layer 142, an over-coating layer 143, and color filter layers 144. In this case, switching devices such as thin film transistors (TFT) are formed on the lower glass substrate 141; and the color filter layers 144 are formed on the upper substrate 145. Also, the spacers (not shown) are provided between the lower and upper glass substrates 141 and 145, to thereby maintain a cell gap therebetween. The liquid crystal layer 142 is filled in a space prepared by the spacers. The over-coating layer 143 on the liquid crystal layer 142 prevents the color filter layers 144 from being damaged, and simultaneously enables a planar surface in pixels. Owing to the color filter layers 144 on the upper glass substrate 145, the light passing through the liquid crystal layer 142 has its own peculiar color.

[0079] The color filter layers 144 include red (R), green (G), and blue (B) color filter layers 144, wherein a black matrix is provided between each of the respective color filter layers 144. Each of the red (R), green (G), and blue (B) color filter layers 144 has a hole 147 to transmit the light there-through.

[0080] At this time, each of the red (R), green (G), and blue (B) color filter layers 144 is formed through the use of photoresist (PR) having its own peculiar color. Also, the hole 147

of the color filter layer **144** may be formed by partially removing the photoresist (PR) for the process of forming the color filter layers **144**.

**[0081]** In the liquid crystal display module according to the second embodiment of the present invention, the three sub-pixels constitute each unit pixel. On the upper glass substrate **145**, the red (R), green (G), and blue (B) color filter layers **144** are arranged in a matrix-type configuration, which are provided to confront the pixel electrodes of the lower glass substrate **141**. In the liquid crystal panel **140** of the liquid crystal display module according to the second embodiment of the present invention, the three sub-pixels of the red (R), green (G), and blue (B) sub-pixels constitute one unit pixel, wherein each of the red (R), green (G), and blue (B) sub-pixels includes the hole **147** to transmit the light therethrough.

**[0082]** Accordingly, each of the red (R), green (G), and blue (B) sub-pixels **144** in the liquid crystal display module according to the second embodiment of the present invention includes the hole **147** to transmit the light therethrough, to thereby improve the light transmittance per unit pixel. Thus, the picture quality can be highly improved owing to the high-luminance light outgoing from the liquid crystal panel **140**.

**[0083]** In the aforementioned explanation, the unit pixel comprises the three sub-pixels including the red (R), green (G), and blue (B) sub-pixels. Another example of the present invention may disclose that the unit pixel may comprise the four sub-pixels including an additional white (W) sub-pixel in addition to the red (R), green (G), and blue (B) sub-pixels.

**[0084]** The WGP **150** is provided on the aforementioned liquid crystal panel **140**, wherein the upper polarizing plate **150** checks horizontally-polarized and vertically-polarized components of the incident light; and selectively transmits or blocks the vertically-polarized or horizontally-polarized component. In this respect, the WGP **150** functions as a general polarizing plate (polarizing film). Among the vertical or horizontal light emitted from the backlight unit, the WGP **150** transmits only light vibrated in the same direction as a polarizing axis; and absorbs or reflects the other types of light, to thereby generate the polarization in a particular direction.

**[0085]** As shown in FIG. 6, the WGP **150** includes a nano-sized grid pattern **154** with conductor lines arranged at a predetermined pitch, wherein the conductor lines are formed of metal. At this time, the grid pattern **154** has the pitch (for example, not more than a half wavelength of visible rays) which is smaller than that of the incident light (for example, visible rays having 400–800 nm wavelength). Thus, the WGP **150** transmits only one type of the polarized components (P-wave or S-wave) among the light emitted from the backlight unit and passing through the liquid crystal panel **140**; and reflects the other type of the polarized components toward the liquid crystal panel **140**. That is, the WGP **150** functions as a polarizing plate which generates a single polarization.

**[0086]** The related art polarizing plate absorbs some of the non-transmitted polarized components from the incident light, whereby the light loss occurs. However, as mentioned above, the WGP **150** of the present invention reflects the non-transmitted polarized components, whereby the light loss is relatively reduced, and the luminance of light outgoing from the liquid crystal panel **140** is increased.

**[0087]** At this time, the WGP **150** includes a polarization area with the grid pattern **154** for polarizing the incident light; and a hole **155** for transmitting the light therethrough. The hole **155** of the WGP **150** is positioned in the area correspond-

ing to each of the holes **147** of the red (R), green (G), blue (B), and white (W) sub-pixels. At this time, the holes **155** of the WGP **150** may be provided for every unit pixel, or may be provided every predetermined number of the unit pixels.

**[0088]** FIG. 6 discloses that the WGP **150** includes one polarizing axis, and the hole **155** for transmitting the light therethrough. However, as shown in FIG. 7, the WGP **150** may the plural polarizing axes, and the hole **155** for transmitting the light therethrough.

**[0089]** As mentioned above, the hole **147** for transmitting the light therethrough is formed in each of the red (R), green (G), and blue (B) sub-pixels constituting the unit pixel; and the holes **155** of the WGP **150** are formed in the areas corresponding to the holes **147** of the color filter layers **144** of the respective sub-pixels.

**[0090]** Thus, the light transmitted through the hole **147** of the sub-pixel is intactly transmitted through the hole **155** of the WGP **150** without being reflected on the WGP **150**. As a result, it is possible to prevent the light loss, which might occur when the light outgoing from the liquid crystal panel **140** passes through the color filter layers **144** and the WGP **150**, to thereby result in improved light efficiency.

**[0091]** In case of the liquid crystal display module according to the related art, when the light passes through the upper polarizing plate and the color filter layer, the light loss inevitably occurs. However, the liquid crystal display module according to the present invention includes the hole **147** in the color filter layer **144** of the sub-pixel, and the hole **155** in the WGP **150**, wherein the hole **155** in the WGP **150** is positioned in the area corresponding to the hole **147** in the color filter layer **144** of the sub-pixel, to thereby improve the light transmittance, as shown in the above table 1.

**[0092]** In the related art, the light source has to be additionally provided to improve the luminance of light outgoing from the liquid crystal panel, whereby the manufacturing cost is increased. However, in case of the liquid crystal display modules according to the embodiments of the present invention, the luminance of light outgoing from the liquid crystal panel can be improved without the additional light source, so that it is possible to reduce the manufacturing cost.

**[0093]** Also, the liquid crystal display module according to the embodiment of the present invention can prevent the increase of power consumption, which might occur when the additional light source is provided to obtain the high luminance.

**[0094]** In the liquid crystal display module according to the embodiment of the present invention, the hole for transmitting the light is formed in the WGP on the liquid crystal panel, so that it is possible to improve the transparency of the liquid crystal display module, and the luminance of the liquid crystal panel.

**[0095]** In addition, the liquid crystal display module according to the present invention enables the decreased manufacturing cost, and the decreased power consumption.

**[0096]** It will be apparent to those skilled in the art that various modifications and variations can be made in the present invention without departing from the spirit or scope of the inventions. Thus, it is intended that the present invention covers the modifications and variations of this invention provided they come within the scope of the appended claims and their equivalents.

What is claimed is:

1. A liquid crystal display module comprising:  
a liquid crystal panel with plural unit pixels, wherein each unit pixel includes red (R), green (G), blue (B), and white (W) sub-pixels, for converting incident light into colored light;  
a light source for supplying light to the liquid crystal panel;  
an optical member for guiding light emitted from the light source toward a frontal direction of the liquid crystal panel; and  
a polarizing means including a polarization area for polarizing the light outgoing from the liquid crystal panel, and a hole for transmitting the light therethrough.
2. The liquid crystal display module according to claim 1, wherein the polarizing means is formed of a wire grid polarizer (WGP) including a nano-sized grid pattern with metal conductor lines arranged at a predetermined pitch.
3. The liquid crystal display module according to claim 2, wherein the hole of the polarizing means is formed in an area corresponding to at least one of the red (R), green (G), blue (B), and white (W) sub-pixels.
4. The liquid crystal display module according to claim 2, wherein the hole of the polarizing means is provided every unit pixels.
5. The liquid crystal display module according to claim 2, wherein a color filter layer of the white (W) sub-pixel is formed of transparent photoresist.
6. A liquid crystal display module comprising:  
a liquid crystal panel with plural unit pixels, wherein each unit pixel includes red (R), green (G), and blue (B) sub-pixels, for converting incident light into colored light;  
a light source for supplying light to the liquid crystal panel;  
an optical member for guiding light emitted from the light source toward a frontal direction of the liquid crystal panel; and  
a polarizing means including a polarization area for polarizing the light outgoing from the liquid crystal panel, and a hole for transmitting the light therethrough.
7. The liquid crystal display module according to claim 6, wherein the polarizing means is formed of a wire grid polarizer (WGP) including a nano-sized grid pattern with metal conductor lines arranged at a predetermined pitch.
8. The liquid crystal display module according to claim 7, wherein each of the red (R), green (G), and blue (B) color filter layers includes a hole to transmit the light therethrough.
9. The liquid crystal display module according to claim 8, wherein the hole of the polarizing means is positioned in an area corresponding to the hole of the color filter layer.
10. The liquid crystal display module according to claim 7, wherein the hole of the polarizing plate is provided every unit pixel.

\* \* \* \* \*

专利名称(译)	液晶显示模块		
公开(公告)号	<a href="#">US20110128475A1</a>	公开(公告)日	2011-06-02
申请号	US12/878600	申请日	2010-09-09
[标]申请(专利权)人(译)	朴钟SIN KIM EUNG DO PARK SE HONG 李敬HA		
申请(专利权)人(译)	朴钟SIN KIM EUNG DO PARK SE HONG 李敬HA		
当前申请(专利权)人(译)	LG DISPLAY CO. , LTD.		
[标]发明人	PARK JONG SIN KIM EUNG DO PARK SE HONG LEE KYUNG HA		
发明人	PARK, JONG SIN KIM, EUNG DO PARK, SE HONG LEE, KYUNG HA		
IPC分类号	G02F1/1335		
CPC分类号	G02F1/133514 G02F2201/52 G02F1/133528 G02F1/133524		
优先权	1020090118440 2009-12-02 KR		
其他公开文献	US8687150		
外部链接	<a href="#">Espacenet</a> <a href="#">USPTO</a>		

摘要(译)

公开了一种液晶显示模块，其通过提高透光率来改善液晶面板的亮度。液晶显示模块包括具有多个单位像素的液晶面板，用于将入射光转换为彩色光，其中每个单位像素包括红色（R），绿色（G），蓝色（B）和白色（W）子像素；用于向液晶面板提供光的光源；光学构件，用于将从光源发出的光导向液晶面板的正面方向；偏振装置包括用于使从液晶面板射出的光偏振的偏振区域，以及用于使光透过的孔。

