



(19) **United States**

(12) **Patent Application Publication**
WATANUKI

(10) **Pub. No.: US 2010/0066752 A1**
(43) **Pub. Date: Mar. 18, 2010**

(54) **LIQUID CRYSTAL DISPLAY DEVICE AND IMAGE DISPLAY METHOD THEREOF**

Publication Classification

(75) Inventor: **Katsumi WATANUKI**, Machida (JP)

(51) **Int. Cl.**
G09G 3/36 (2006.01)
G09G 5/02 (2006.01)
(52) **U.S. Cl.** **345/589; 345/102**

Correspondence Address:
MOTS LAW, PLLC
1629 K STREET N.W., SUITE 602
WASHINGTON, DC 20006-1635 (US)

(57) **ABSTRACT**

A liquid crystal panel displays an image from image signals. A backlight device is disposed on the back side of the liquid crystal panel, and is divided into a plurality of regions. The backlight device comprises light sources in each of the regions. The light sources are positioned to emit light onto the liquid crystal panel. A histogram detector detects an image signal gradation distribution for each region and to produce a histogram therefrom. An image gain calculator calculates a gain from the detected gradation distribution of the histogram detector, and controls light emission from each light source in each region of the backlight device. A light emission luminance calculator controls the light emission luminance of each light source based on a maximum luminance of the light sources and based on an inverse number of the gain calculated in the image gain calculator.

(73) Assignee: **Victor Company of Japan, Limited**, Yokohama (JP)

(21) Appl. No.: **12/504,623**

(22) Filed: **Jul. 16, 2009**

(30) **Foreign Application Priority Data**

Sep. 18, 2008 (JP) JP2008-239039

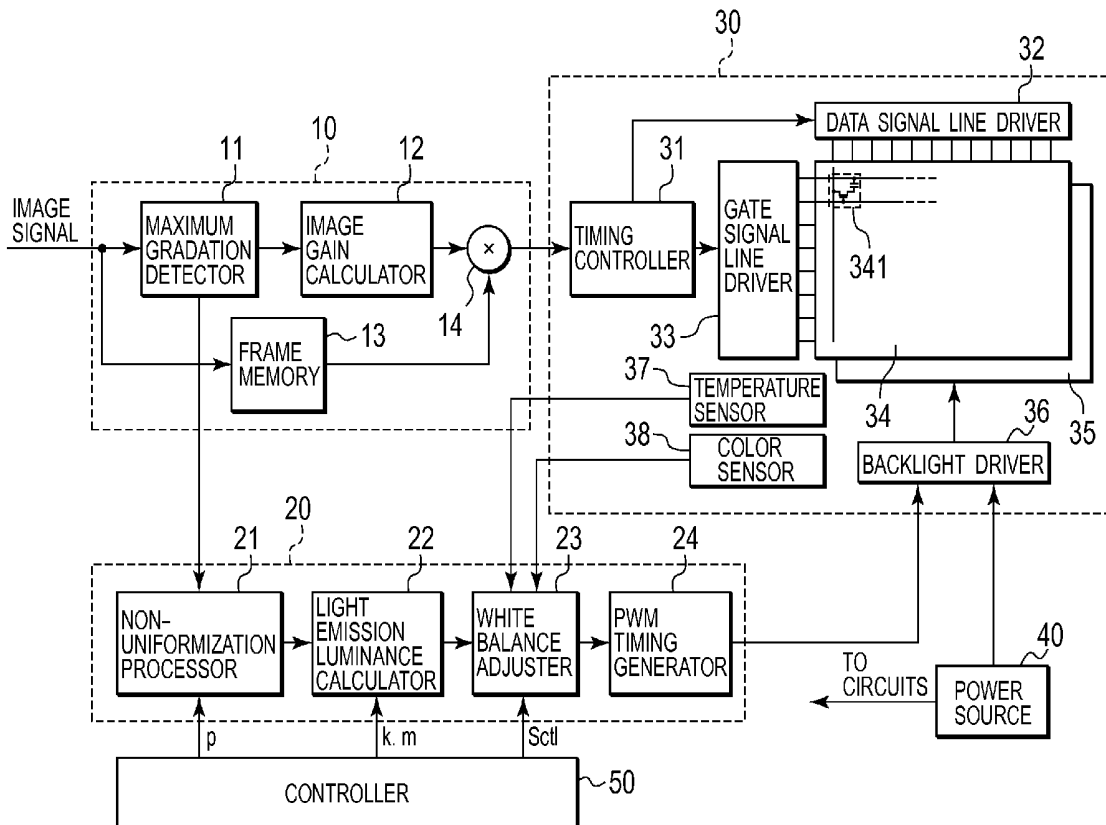

FIG. 1

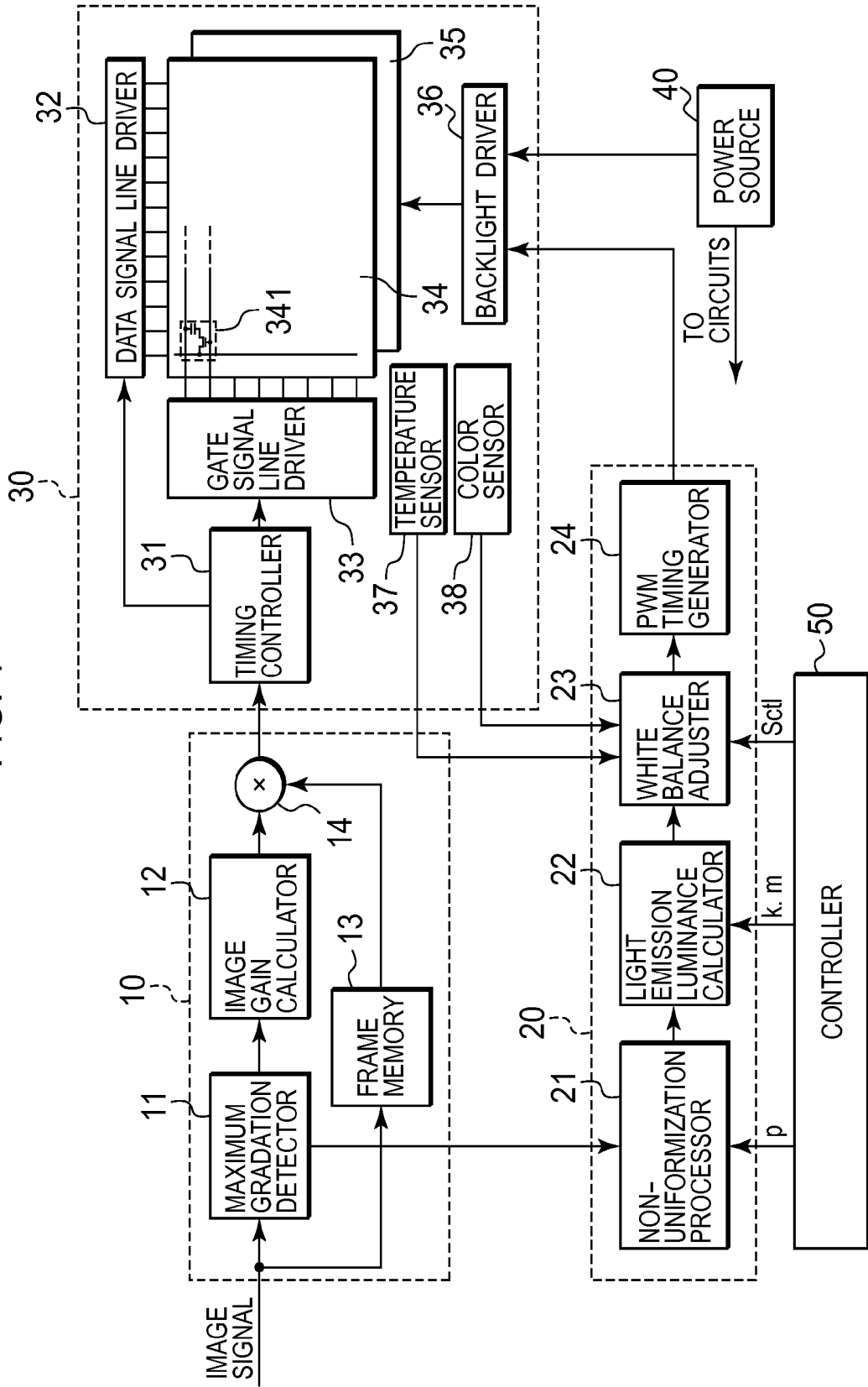

FIG. 2

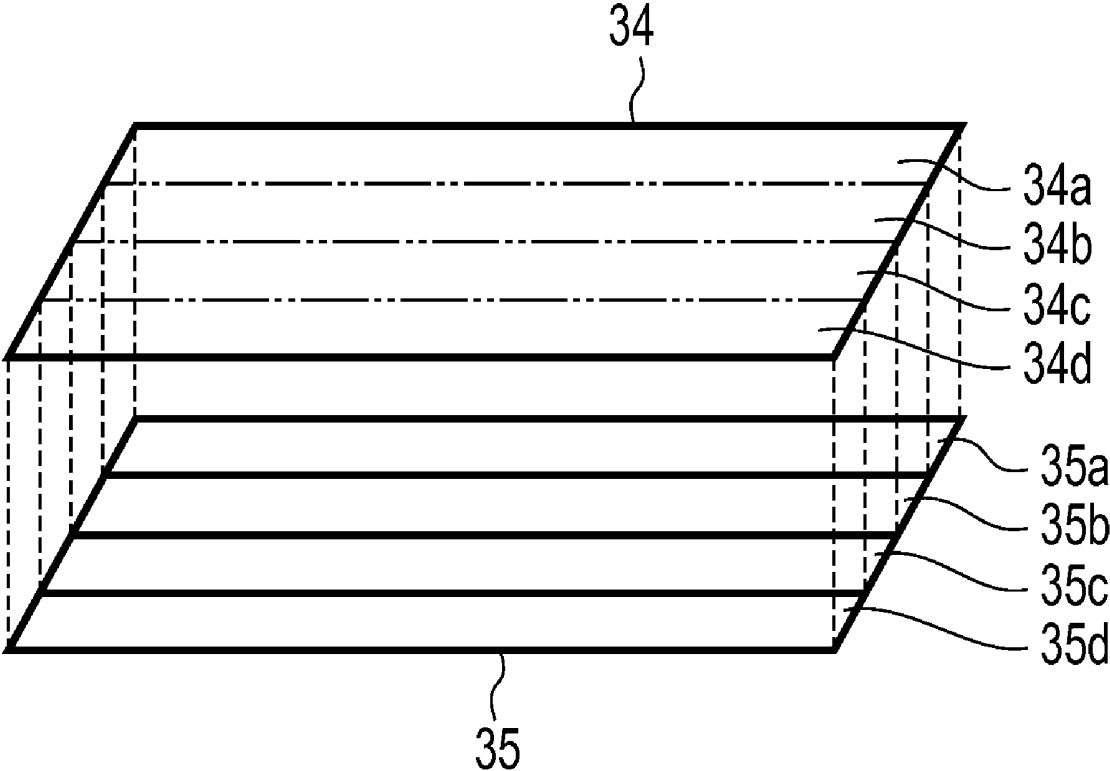

FIG. 3A

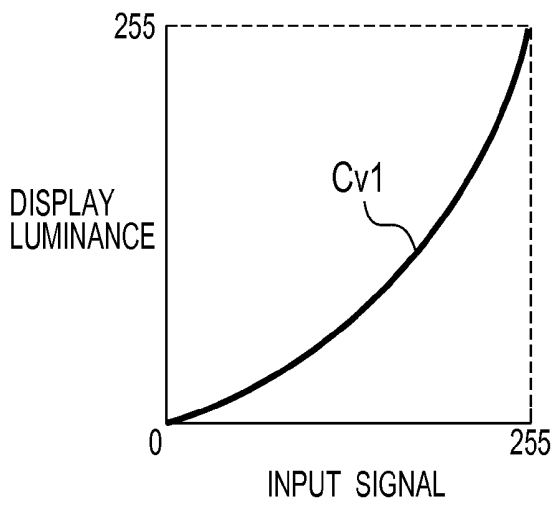

FIG. 3B

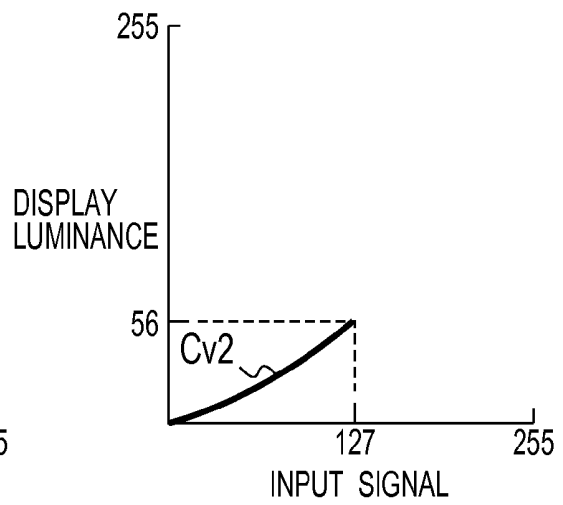

FIG. 3C

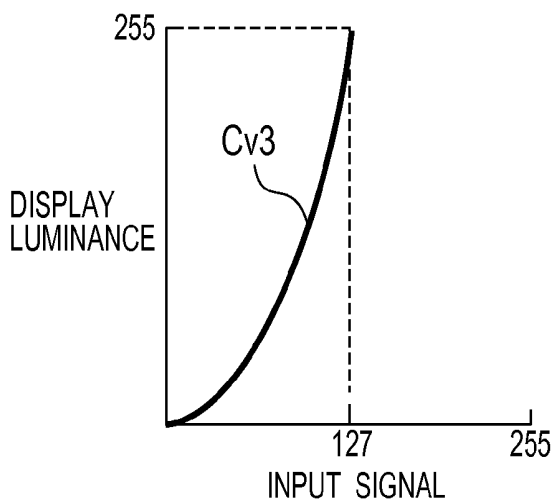

FIG. 3D

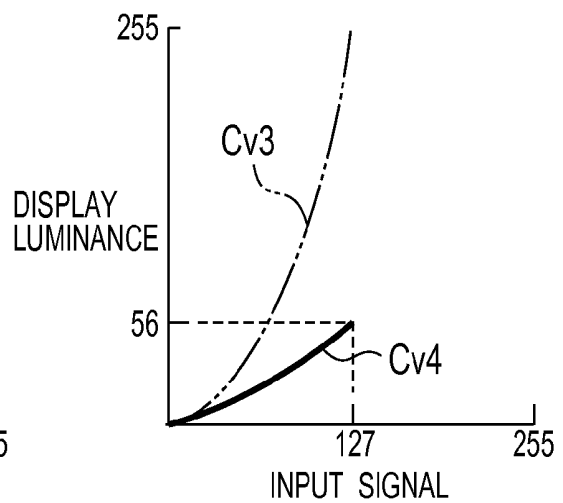

FIG. 4B

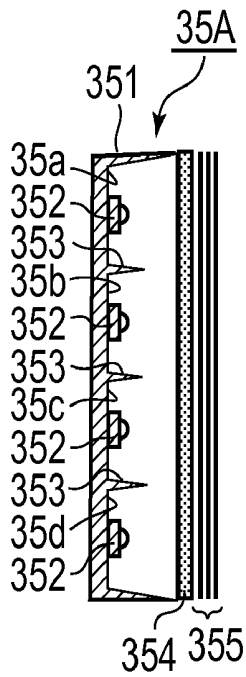

FIG. 4A

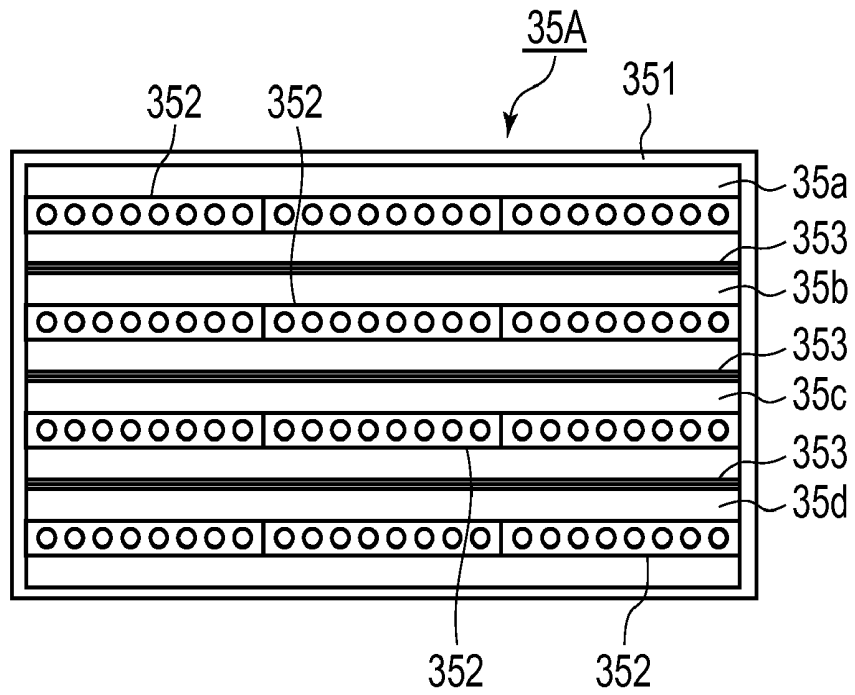

FIG. 5B

FIG. 5A

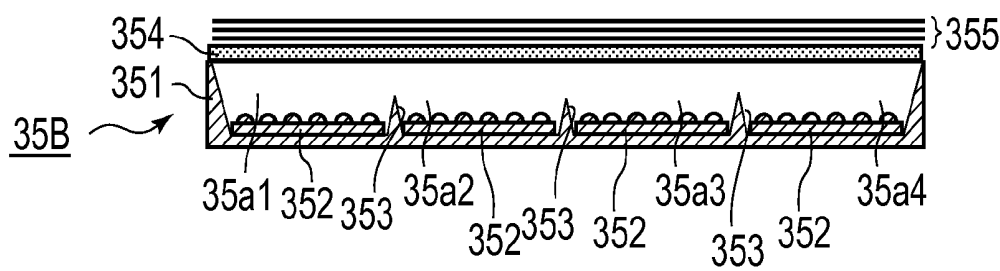
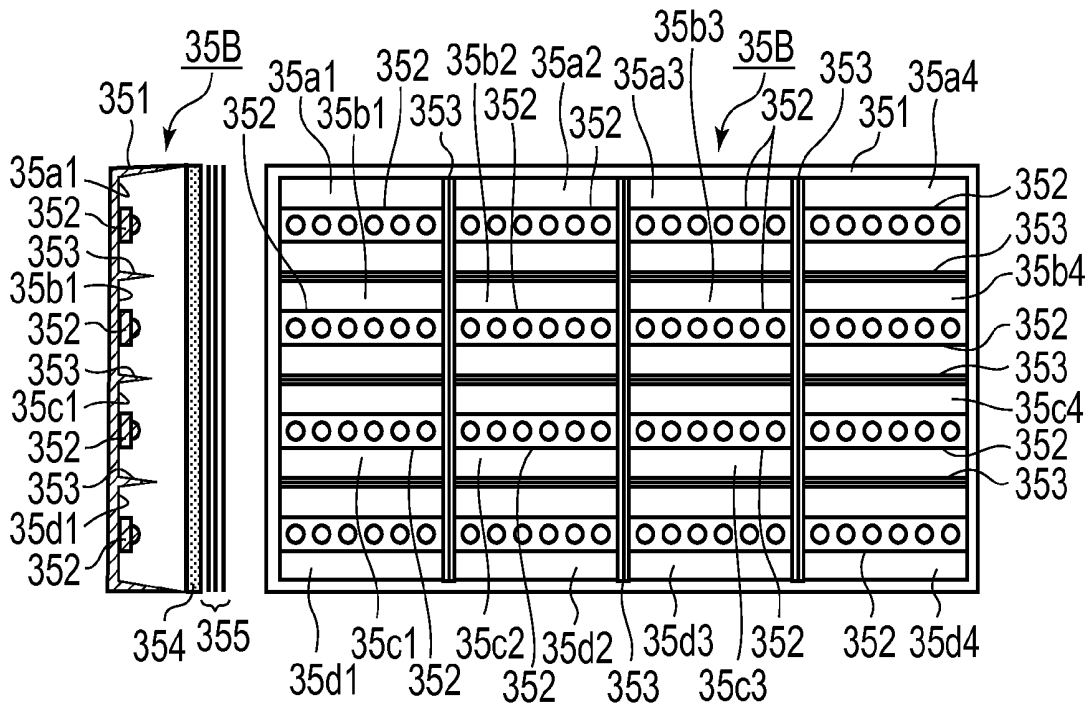

FIG. 5C

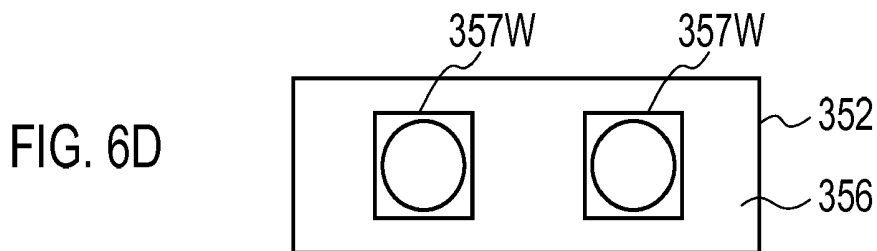
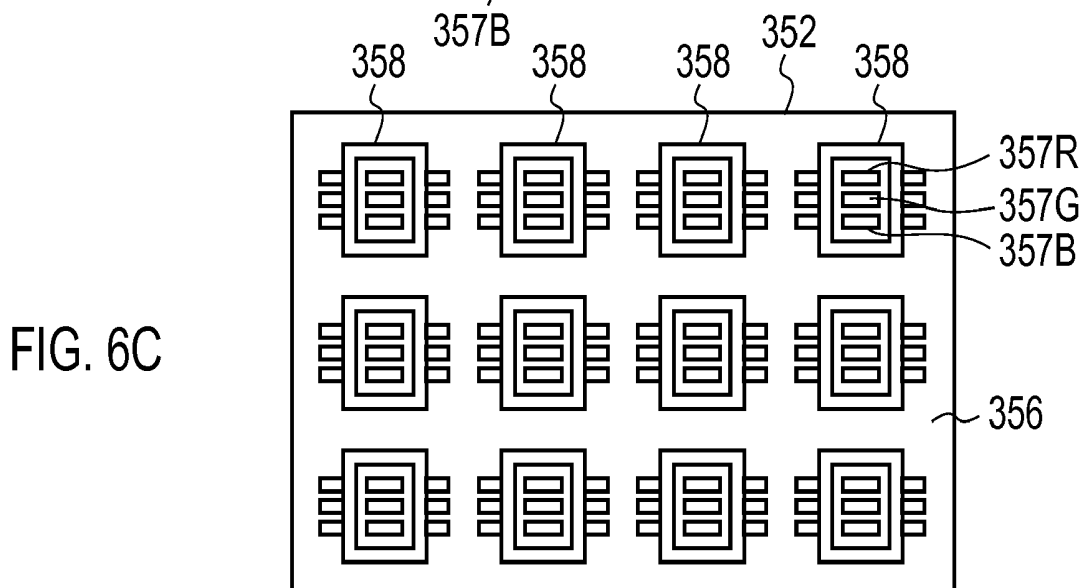
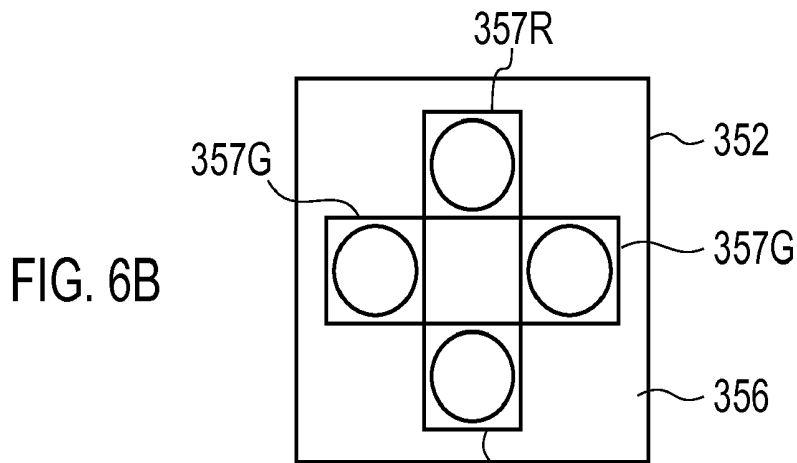
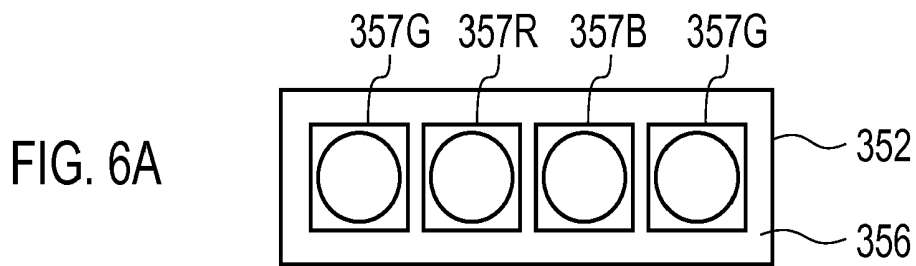
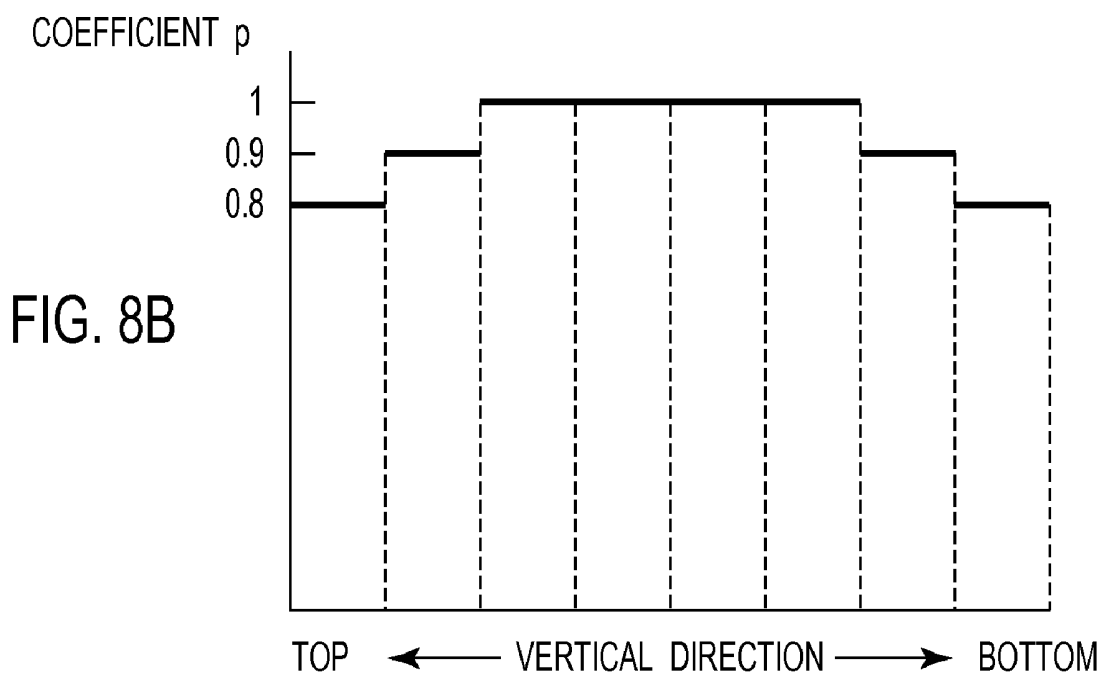
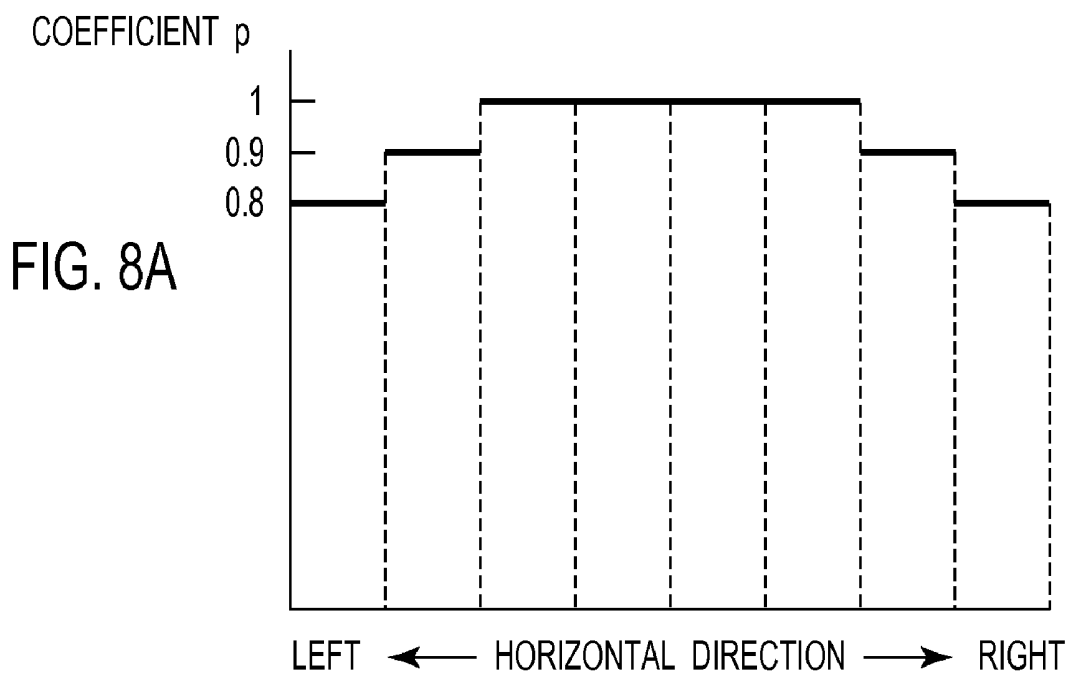

FIG. 7

35

35a1	35a2	35a3	35a4	35a5	35a6	35a7	35a8
35b1	35b2	35b3	35b4	35b5	35b6	35b7	35b8
35c1	35c2	35c3	35c4	35c5	35c6	35c7	35c8
35d1	35d2	35d3	35d4	35d5	35d6	35d7	35d8
35e1	35e2	35e3	35e4	35e5	35e6	35e7	35e8
35f1	35f2	35f3	35f4	35f5	35f6	35f7	35f8
35g1	35g2	35g3	35g4	35g5	35g6	35g7	35g8
35h1	35h2	35h3	35h4	35h5	35h6	35h7	35h8



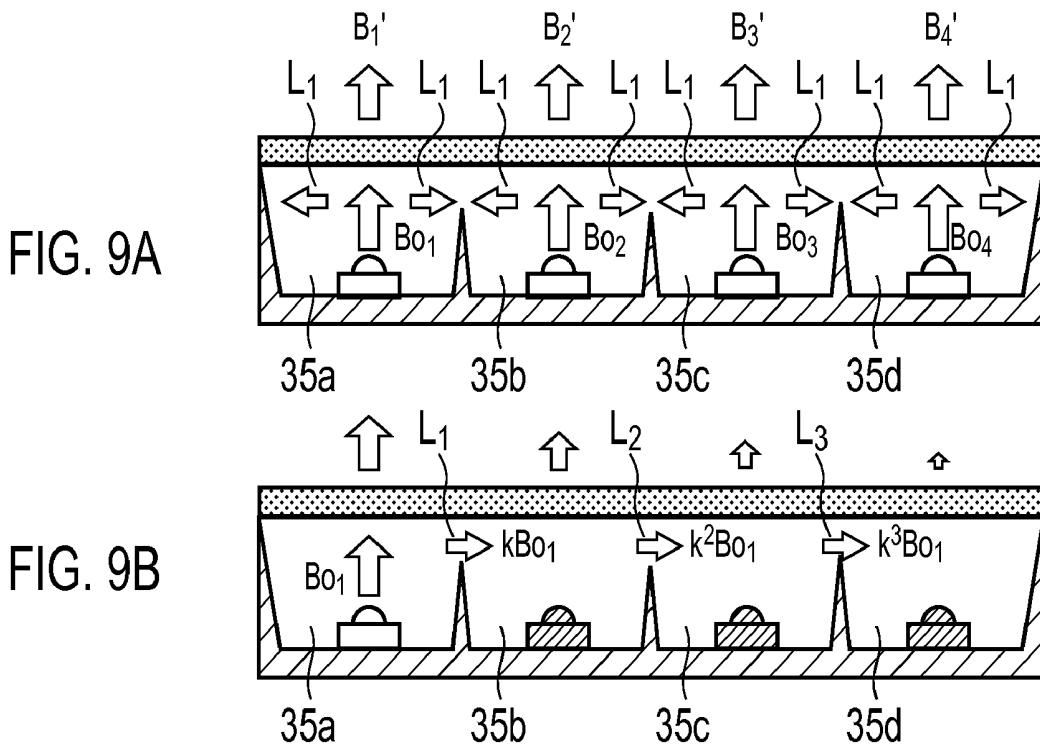

FIG. 10

	LUMINANCE ON REGION 35a	LUMINANCE ON REGION 35b	LUMINANCE ON REGION 35c	LUMINANCE ON REGION 35d
LIGHTING ONLY ON REGION 35a	B_{01}	kB_{01}	k^2B_{01}	k^3B_{01}
LIGHTING ONLY ON REGION 35b	kB_{02}	B_{02}	kB_{02}	k^2B_{02}
LIGHTING ONLY ON REGION 35c	k^2B_{03}	kB_{03}	B_{03}	kB_{03}
LIGHTING ONLY ON REGION 35d	k^3B_{04}	k^2B_{04}	kB_{04}	B_{04}

FIG. 11A

$$\begin{bmatrix} B_1' \\ B_2' \\ B_3' \\ B_4' \end{bmatrix} = \begin{bmatrix} 1 & k & k^2 & k^3 \\ k & 1 & k & k^2 \\ k^2 & k & 1 & k \\ k^3 & k^2 & k & 1 \end{bmatrix} \begin{bmatrix} B_{01} \\ B_{02} \\ B_{03} \\ B_{04} \end{bmatrix} \quad \dots (1)$$

FIG. 11B

$$\begin{bmatrix} B_{01} \\ B_{02} \\ B_{03} \\ B_{04} \end{bmatrix} = \begin{bmatrix} 1 & k & k^2 & k^3 \\ k & 1 & k & k^2 \\ k^2 & k & 1 & k \\ k^3 & k^2 & k & 1 \end{bmatrix}^{-1} \begin{bmatrix} B_1' \\ B_2' \\ B_3' \\ B_4' \end{bmatrix} \quad \dots (2)$$

FIG. 11C

$$\begin{bmatrix} B_{01} \\ B_{02} \\ B_{03} \\ B_{04} \end{bmatrix} = \begin{bmatrix} c & b & 0 & 0 \\ b & a & b & 0 \\ 0 & b & a & b \\ 0 & 0 & b & c \end{bmatrix} \begin{bmatrix} B_1' \\ B_2' \\ B_3' \\ B_4' \end{bmatrix} \quad \dots (3)$$

FIG. 11D

$$a = \frac{1+k^2}{1-k^2}, \quad b = \frac{-k}{1-k^2}, \quad c = \frac{1}{1-k^2} \quad \dots (4)$$

FIG. 12

$$\begin{bmatrix} B_{01} \\ B_{02} \\ B_{03} \\ B_{04} \\ B_{05} \\ B_{06} \\ B_{07} \\ B_{08} \end{bmatrix} = \begin{bmatrix} c & b & 0 & 0 & 0 & 0 & 0 & 0 \\ b & a & b & 0 & 0 & 0 & 0 & 0 \\ 0 & b & a & b & 0 & 0 & 0 & 0 \\ 0 & 0 & b & a & b & 0 & 0 & 0 \\ 0 & 0 & 0 & b & a & b & 0 & 0 \\ 0 & 0 & 0 & 0 & b & a & b & 0 \\ 0 & 0 & 0 & 0 & 0 & b & a & b \\ 0 & 0 & 0 & 0 & 0 & 0 & b & c \end{bmatrix} \begin{bmatrix} B_1' \\ B_2' \\ B_3' \\ B_4' \\ B_5' \\ B_6' \\ B_7' \\ B_8' \end{bmatrix} \dots (5)$$

FIG. 13A

$$\begin{bmatrix} B_1' \\ B_2' \\ \vdots \\ \vdots \\ B_{n-1}' \\ B_n' \end{bmatrix} = \begin{bmatrix} 1 & k & \dots & \dots & k^{n-2} & k^{n-1} \\ k & 1 & \dots & \dots & k^{n-3} & k^{n-2} \\ \vdots & \vdots & \ddots & \ddots & \vdots & \vdots \\ \vdots & \vdots & \ddots & \ddots & \vdots & \vdots \\ k^{n-2} & k^{n-3} & \dots & \dots & 1 & k \\ k^{n-1} & k^{n-2} & \dots & \dots & k & 1 \end{bmatrix} \begin{bmatrix} B_{01} \\ B_{02} \\ \vdots \\ \vdots \\ B_{0n-1} \\ B_{0n} \end{bmatrix} \dots (6)$$

FIG. 13B

$$\begin{bmatrix} B_{01} \\ B_{02} \\ \vdots \\ \vdots \\ B_{0n-1} \\ B_{0n} \end{bmatrix} = \begin{bmatrix} c & b & \dots & \dots & 0 & 0 \\ b & a & \dots & \dots & 0 & 0 \\ \vdots & \vdots & \ddots & \ddots & \vdots & \vdots \\ \vdots & \vdots & \ddots & \ddots & \vdots & \vdots \\ 0 & 0 & \dots & \dots & a & b \\ 0 & 0 & \dots & \dots & b & c \end{bmatrix} \begin{bmatrix} B_1' \\ B_2' \\ \vdots \\ \vdots \\ B_{n-1}' \\ B_n' \end{bmatrix} \dots (7)$$

FIG. 14

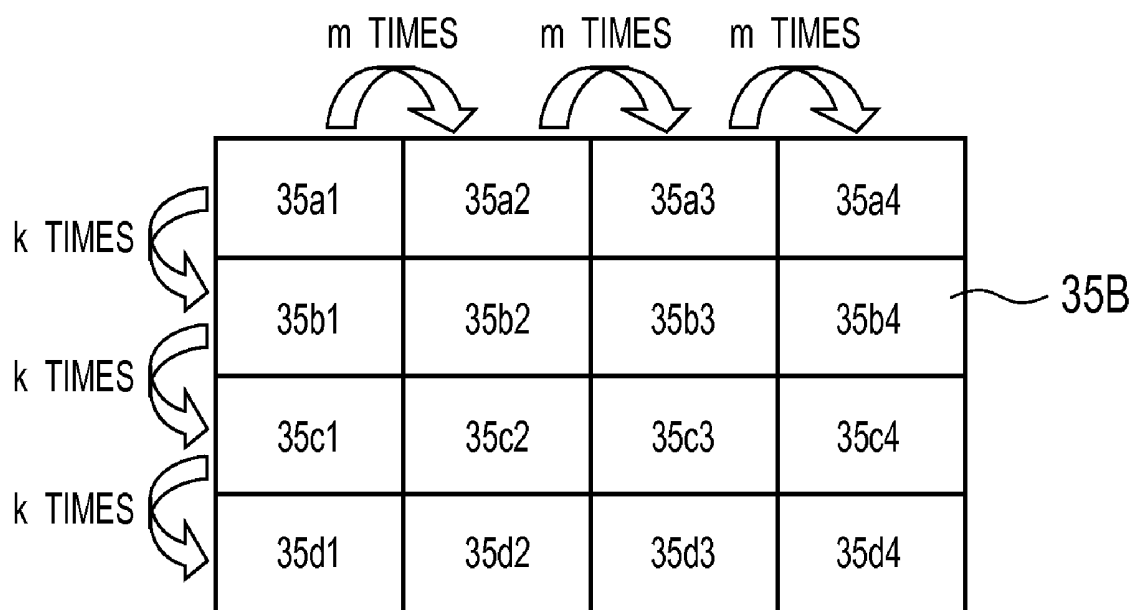

FIG. 15A

$$\begin{bmatrix} B_{11}' & B_{12}' & B_{13}' & B_{14}' \\ B_{21}' & B_{22}' & B_{23}' & B_{24}' \\ B_{31}' & B_{32}' & B_{33}' & B_{34}' \\ B_{41}' & B_{42}' & B_{43}' & B_{44}' \end{bmatrix} = \begin{bmatrix} 1 & k & k^2 & k^3 \\ k & 1 & k & k^2 \\ k^2 & k & 1 & k \\ k^3 & k^2 & k & 1 \end{bmatrix} \begin{bmatrix} B_{011} & B_{012} & B_{013} & B_{014} \\ B_{021} & B_{022} & B_{023} & B_{024} \\ B_{031} & B_{032} & B_{033} & B_{034} \\ B_{041} & B_{042} & B_{043} & B_{044} \end{bmatrix} \begin{bmatrix} 1 & m & m^2 & m^3 \\ m & 1 & m & m^2 \\ m^2 & m & 1 & m \\ m^3 & m^2 & m & 1 \end{bmatrix} \quad \dots (8)$$

FIG. 15B

$$\begin{bmatrix} B_{011} & B_{012} & B_{013} & B_{014} \\ B_{021} & B_{022} & B_{023} & B_{024} \\ B_{031} & B_{032} & B_{033} & B_{034} \\ B_{041} & B_{042} & B_{043} & B_{044} \end{bmatrix} = \begin{bmatrix} 1 & k & k^2 & k^3 \\ k & 1 & k & k^2 \\ k^2 & k & 1 & k \\ k^3 & k^2 & k & 1 \end{bmatrix}^{-1} \begin{bmatrix} B_{11}' & B_{12}' & B_{13}' & B_{14}' \\ B_{21}' & B_{22}' & B_{23}' & B_{24}' \\ B_{31}' & B_{32}' & B_{33}' & B_{34}' \\ B_{41}' & B_{42}' & B_{43}' & B_{44}' \end{bmatrix} \begin{bmatrix} 1 & m & m^2 & m^3 \\ m & 1 & m & m^2 \\ m^2 & m & 1 & m \\ m^3 & m^2 & m & 1 \end{bmatrix}^{-1} \quad \dots (9)$$

FIG. 15C

$$\begin{bmatrix} B_{011} & B_{012} & B_{013} & B_{014} \\ B_{021} & B_{022} & B_{023} & B_{024} \\ B_{031} & B_{032} & B_{033} & B_{034} \\ B_{041} & B_{042} & B_{043} & B_{044} \end{bmatrix} = \begin{bmatrix} c & b & 0 & 0 \\ b & a & b & 0 \\ 0 & b & a & b \\ 0 & 0 & b & c \end{bmatrix} \begin{bmatrix} B_{11}' & B_{12}' & B_{13}' & B_{14}' \\ B_{21}' & B_{22}' & B_{23}' & B_{24}' \\ B_{31}' & B_{32}' & B_{33}' & B_{34}' \\ B_{41}' & B_{42}' & B_{43}' & B_{44}' \end{bmatrix} \begin{bmatrix} f & e & 0 & 0 \\ e & d & e & 0 \\ 0 & e & d & e \\ 0 & 0 & e & f \end{bmatrix} \quad \dots (10)$$

FIG. 15D

$$a = \frac{1+k^2}{1-k^2}, \quad b = \frac{-k}{1-k^2}, \quad c = \frac{1}{1-k^2}, \quad d = \frac{1+m^2}{1-m^2}, \quad e = \frac{-m}{1-m^2}, \quad f = \frac{1}{1-m^2} \quad \dots (11)$$

FIG. 16A

$$\begin{bmatrix} B_{011}' & B_{012}' & B_{013}' & B_{014}' & B_{015}' & B_{016}' & B_{017}' & B_{018}' \\ B_{021}' & B_{022}' & B_{023}' & B_{024}' & B_{025}' & B_{026}' & B_{027}' & B_{028}' \\ B_{031}' & B_{032}' & B_{033}' & B_{034}' & B_{035}' & B_{036}' & B_{037}' & B_{038}' \\ B_{041}' & B_{042}' & B_{043}' & B_{044}' & B_{045}' & B_{046}' & B_{047}' & B_{048}' \\ B_{051}' & B_{052}' & B_{053}' & B_{054}' & B_{055}' & B_{056}' & B_{057}' & B_{058}' \\ B_{061}' & B_{062}' & B_{063}' & B_{064}' & B_{065}' & B_{066}' & B_{067}' & B_{068}' \\ B_{071}' & B_{072}' & B_{073}' & B_{074}' & B_{075}' & B_{076}' & B_{077}' & B_{078}' \\ B_{081}' & B_{082}' & B_{083}' & B_{084}' & B_{085}' & B_{086}' & B_{087}' & B_{088}' \end{bmatrix} = \begin{bmatrix} 1 & k & k^2 & k^3 & k^4 & k^5 & k^6 & k^7 \\ k & 1 & k & k^2 & k^3 & k^4 & k^5 & k^6 \\ k^2 & k & 1 & k & k^2 & k^3 & k^4 & k^5 \\ k^3 & k^2 & k & 1 & k & k^2 & k^3 & k^4 \\ k^4 & k^3 & k^2 & k & 1 & k & k^2 & k^3 \\ k^5 & k^4 & k^3 & k^2 & k & 1 & k & k^2 \\ k^6 & k^5 & k^4 & k^3 & k^2 & k & 1 & k \\ k^7 & k^6 & k^5 & k^4 & k^3 & k^2 & k & 1 \end{bmatrix} = \begin{bmatrix} 1 & m & m^2 & m^3 & m^4 & m^5 & m^6 & m^7 \\ m & 1 & m & m^2 & m^3 & m^4 & m^5 & m^6 \\ m^2 & m & 1 & m & m^2 & m^3 & m^4 & m^5 \\ m^3 & m^2 & m & 1 & m & m^2 & m^3 & m^4 \\ m^4 & m^3 & m^2 & m & 1 & m & m^2 & m^3 \\ m^5 & m^4 & m^3 & m^2 & m & 1 & m & m^2 \\ m^6 & m^5 & m^4 & m^3 & m^2 & m & 1 & m \\ m^7 & m^6 & m^5 & m^4 & m^3 & m^2 & m & 1 \end{bmatrix}$$

... (12)

FIG. 16B

$$\begin{bmatrix} B_{011}' & B_{012}' & B_{013}' & B_{014}' & B_{015}' & B_{016}' & B_{017}' & B_{018}' \\ B_{021}' & B_{022}' & B_{023}' & B_{024}' & B_{025}' & B_{026}' & B_{027}' & B_{028}' \\ B_{031}' & B_{032}' & B_{033}' & B_{034}' & B_{035}' & B_{036}' & B_{037}' & B_{038}' \\ B_{041}' & B_{042}' & B_{043}' & B_{044}' & B_{045}' & B_{046}' & B_{047}' & B_{048}' \\ B_{051}' & B_{052}' & B_{053}' & B_{054}' & B_{055}' & B_{056}' & B_{057}' & B_{058}' \\ B_{061}' & B_{062}' & B_{063}' & B_{064}' & B_{065}' & B_{066}' & B_{067}' & B_{068}' \\ B_{071}' & B_{072}' & B_{073}' & B_{074}' & B_{075}' & B_{076}' & B_{077}' & B_{078}' \\ B_{081}' & B_{082}' & B_{083}' & B_{084}' & B_{085}' & B_{086}' & B_{087}' & B_{088}' \end{bmatrix} = \begin{bmatrix} c & b & 0 & 0 & 0 & 0 & 0 & 0 \\ b & a & b & 0 & 0 & 0 & 0 & 0 \\ 0 & b & a & b & 0 & 0 & 0 & 0 \\ 0 & 0 & b & a & b & 0 & 0 & 0 \\ 0 & 0 & 0 & b & a & b & 0 & 0 \\ 0 & 0 & 0 & 0 & b & a & b & 0 \\ 0 & 0 & 0 & 0 & 0 & b & a & b \\ 0 & 0 & 0 & 0 & 0 & 0 & b & c \end{bmatrix} = \begin{bmatrix} f & e & 0 & 0 & 0 & 0 & 0 & 0 \\ e & d & e & 0 & 0 & 0 & 0 & 0 \\ 0 & e & d & e & 0 & 0 & 0 & 0 \\ 0 & 0 & e & d & e & 0 & 0 & 0 \\ 0 & 0 & 0 & e & d & e & 0 & 0 \\ 0 & 0 & 0 & 0 & e & d & e & 0 \\ 0 & 0 & 0 & 0 & 0 & e & d & e \\ 0 & 0 & 0 & 0 & 0 & 0 & e & f \end{bmatrix}$$

... (13)

FIG. 17

$$\begin{bmatrix} B_{011} & B_{012} & B_{013} & \dots & B_{01,n-2} & B_{01,n-1} & B_{01,n} \\ B_{021} & B_{022} & B_{023} & \dots & B_{02,n-2} & B_{02,n-1} & B_{02,n} \\ B_{031} & B_{032} & B_{033} & \dots & B_{03,n-2} & B_{03,n-1} & B_{03,n} \\ \vdots & \vdots & \vdots & \ddots & \vdots & \vdots & \vdots \\ \vdots & \vdots & \vdots & \ddots & \vdots & \vdots & \vdots \\ B_{0_{n-2},1} & B_{0_{n-2},2} & B_{0_{n-2},3} & \dots & B_{0_{n-2},n-2} & B_{0_{n-2},n-1} & B_{0_{n-2},n} \\ B_{0_{n-1},1} & B_{0_{n-1},2} & B_{0_{n-1},3} & \dots & B_{0_{n-1},n-2} & B_{0_{n-1},n-1} & B_{0_{n-1},n} \\ B_{0_{n},1} & B_{0_{n},2} & B_{0_{n},3} & \dots & B_{0_{n},n-2} & B_{0_{n},n-1} & B_{0_{n},n} \end{bmatrix} = \begin{bmatrix} c & b & 0 & \dots & 0 & 0 & 0 & 0 \\ b & a & b & \dots & 0 & 0 & 0 & 0 \\ 0 & b & a & \dots & 0 & 0 & 0 & 0 \\ \vdots & \vdots & \vdots & \ddots & \vdots & \vdots & \vdots & \vdots \\ \vdots & \vdots & \vdots & \ddots & \vdots & \vdots & \vdots & \vdots \\ 0 & 0 & 0 & \dots & a & b & 0 & 0 \\ 0 & 0 & 0 & \dots & b & a & b & 0 \\ 0 & 0 & 0 & \dots & 0 & b & c & 0 \end{bmatrix} = \begin{bmatrix} B_{11}' & B_{12}' & B_{13}' & \dots & B_{1,n-2}' & B_{1,n-1}' & B_{1,n}' \\ B_{21}' & B_{22}' & B_{23}' & \dots & B_{2,n-2}' & B_{2,n-1}' & B_{2,n}' \\ B_{31}' & B_{32}' & B_{33}' & \dots & B_{3,n-2}' & B_{3,n-1}' & B_{3,n}' \\ \vdots & \vdots & \vdots & \ddots & \vdots & \vdots & \vdots \\ \vdots & \vdots & \vdots & \ddots & \vdots & \vdots & \vdots \\ B_{n-2,1}' & B_{n-2,2}' & B_{n-2,3}' & \dots & B_{n-2,n-2}' & B_{n-2,n-1}' & B_{n-2,n}' \\ B_{n-1,1}' & B_{n-1,2}' & B_{n-1,3}' & \dots & B_{n-1,n-2}' & B_{n-1,n-1}' & B_{n-1,n}' \\ B_{n,1}' & B_{n,2}' & B_{n,3}' & \dots & B_{n,n-2}' & B_{n,n-1}' & B_{n,n}' \end{bmatrix} \begin{bmatrix} f & e & 0 & \dots & 0 & 0 & 0 & 0 \\ e & d & e & \dots & 0 & 0 & 0 & 0 \\ 0 & e & d & \dots & 0 & 0 & 0 & 0 \\ \vdots & \vdots & \vdots & \ddots & \vdots & \vdots & \vdots & \vdots \\ \vdots & \vdots & \vdots & \ddots & \vdots & \vdots & \vdots & \vdots \\ 0 & 0 & 0 & \dots & d & e & 0 & 0 \\ 0 & 0 & 0 & \dots & e & d & e & 0 \\ 0 & 0 & 0 & \dots & 0 & e & f & 0 \end{bmatrix} \dots (14)$$

FIG. 18

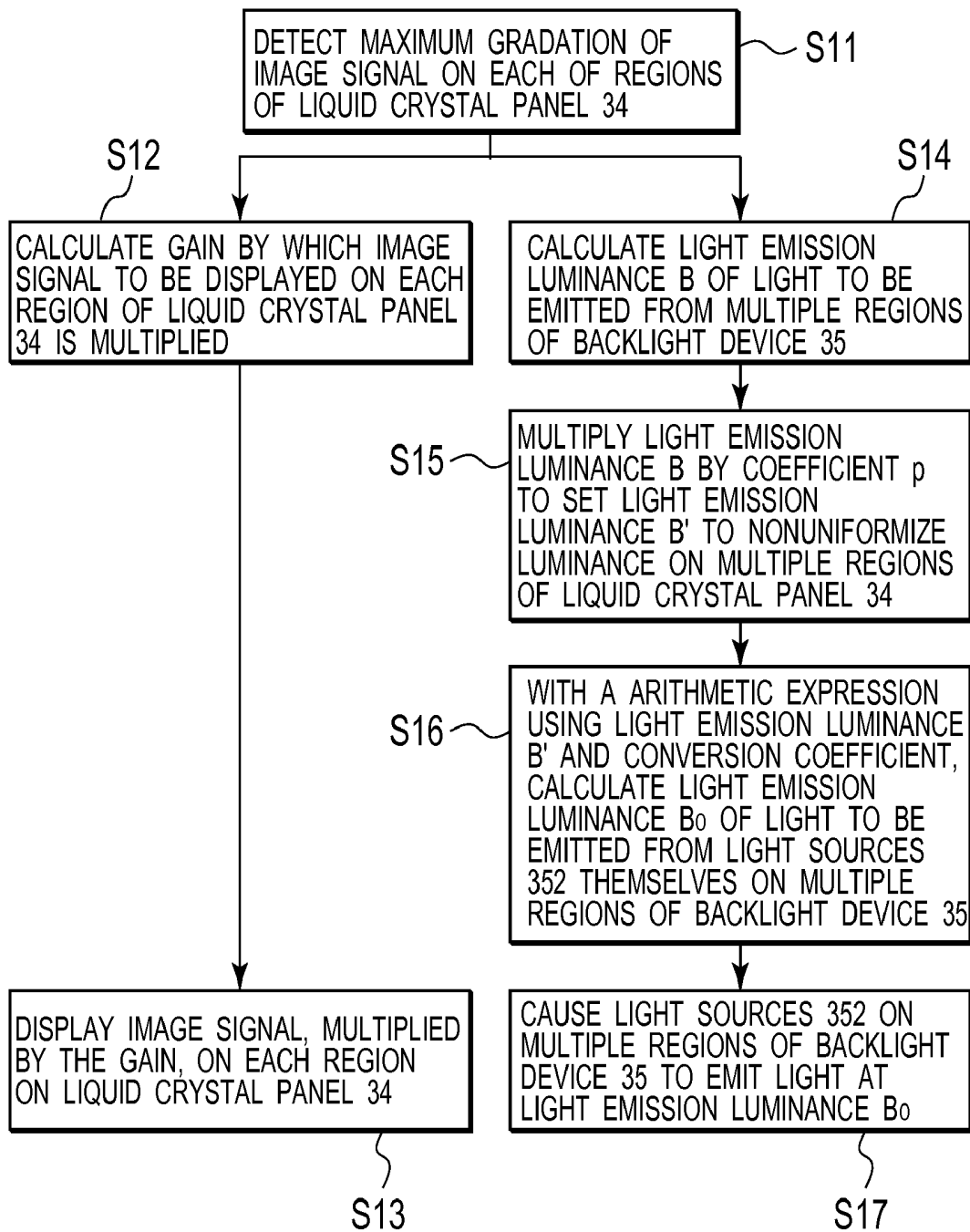

FIG. 19

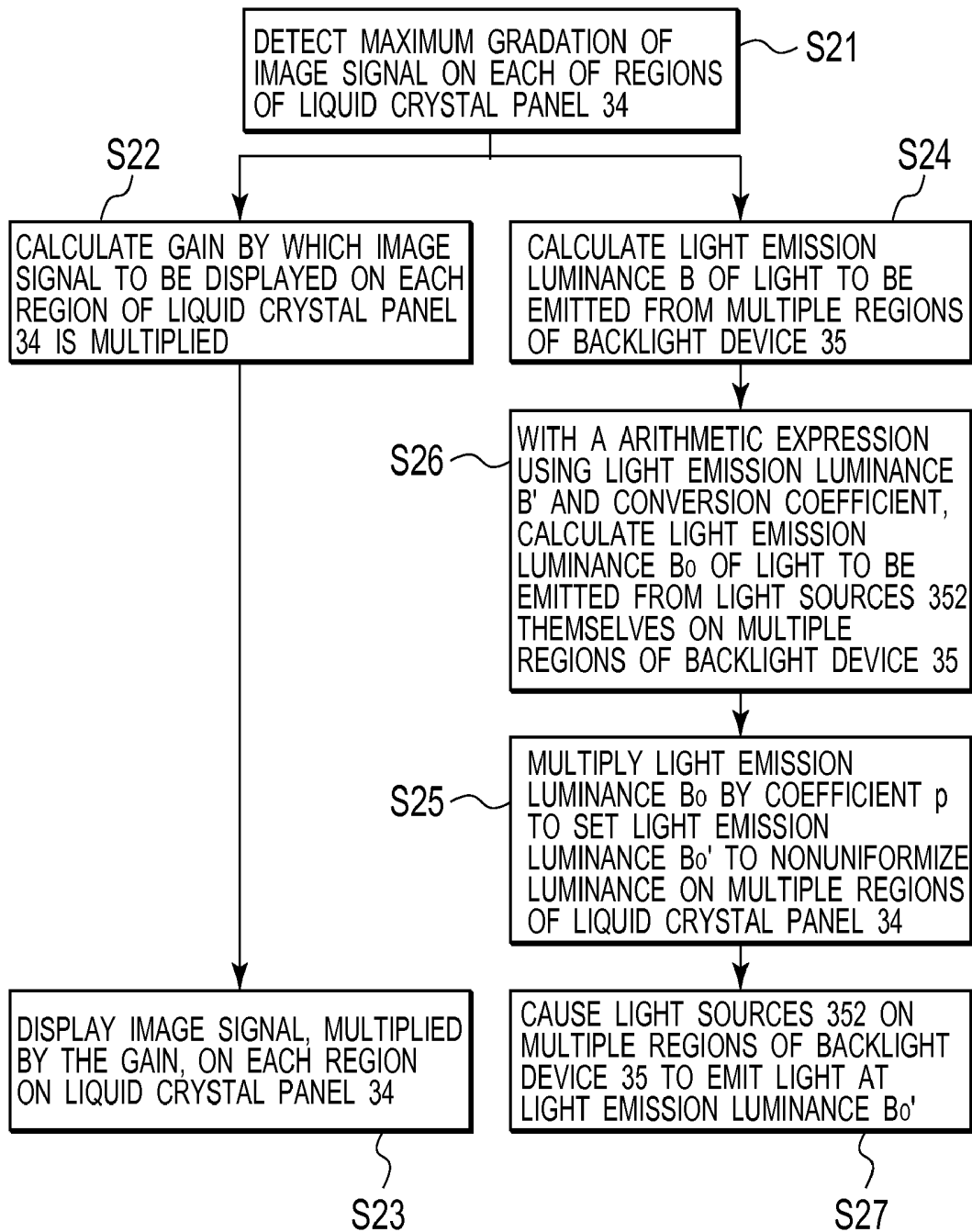

FIG. 20

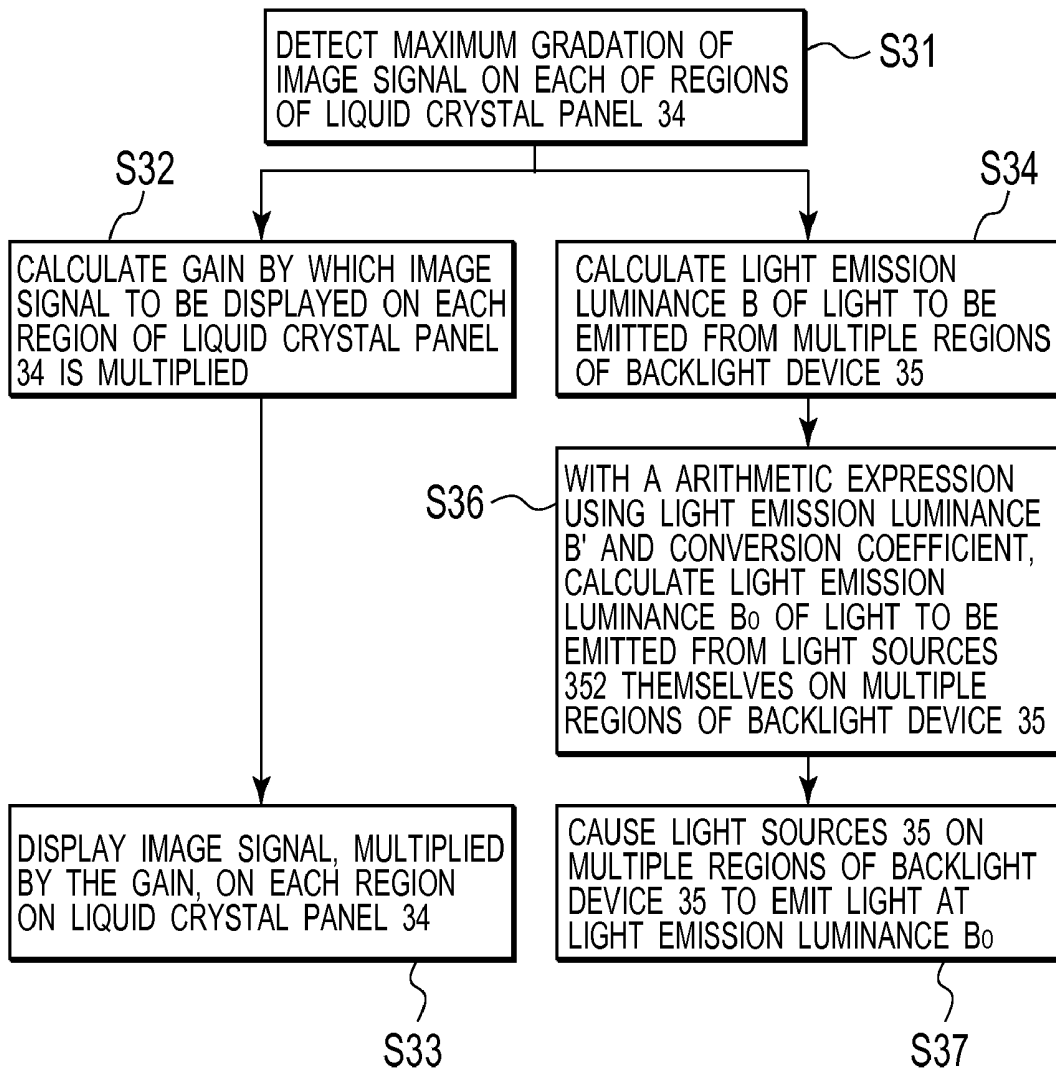

FIG. 22A

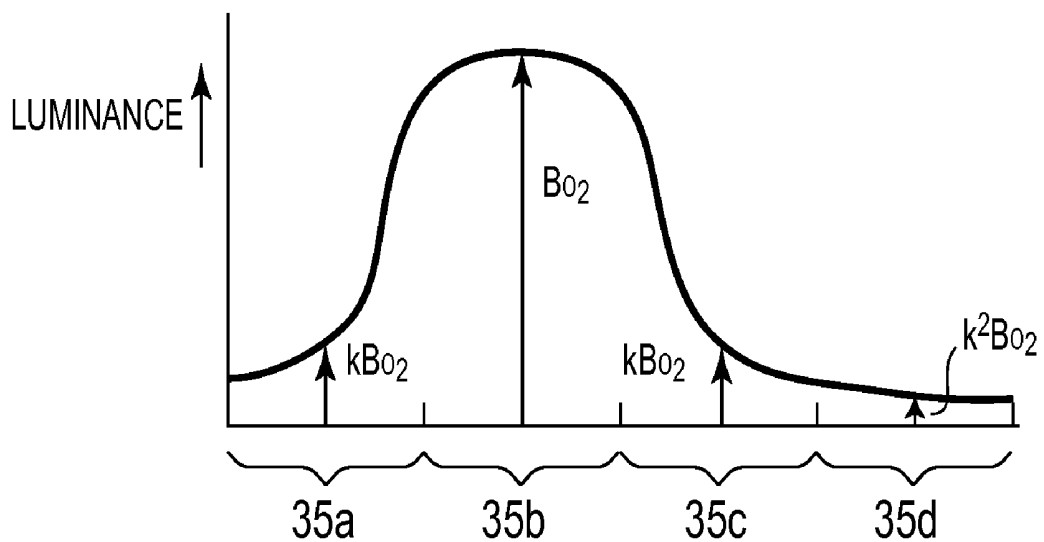

FIG. 22B

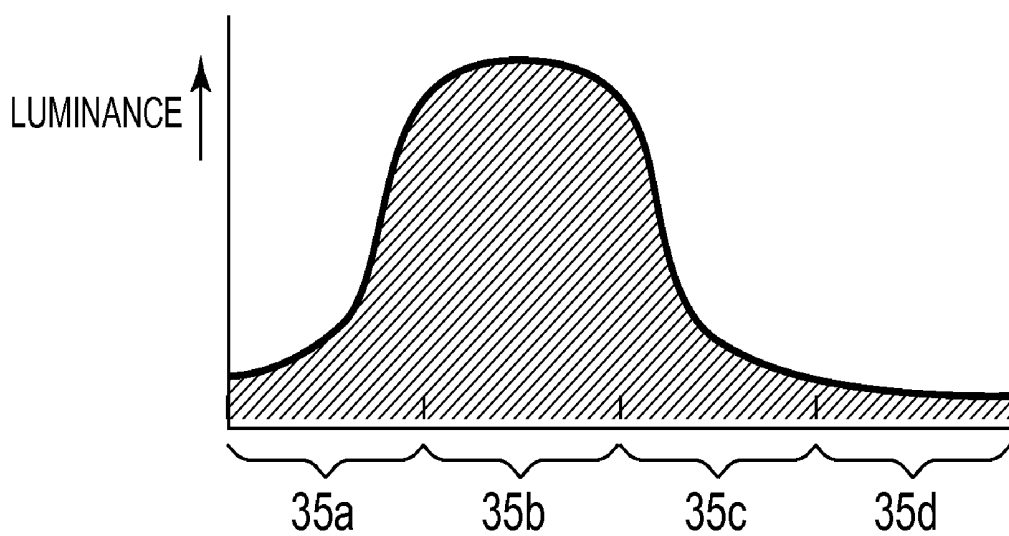

FIG. 23A

$$\begin{bmatrix} B_{0ig1} \\ B_{0ig2} \\ B_{0ig3} \\ B_{0ig4} \end{bmatrix} = \begin{bmatrix} s_1 & 0 & 0 & 0 \\ 0 & s_2 & 0 & 0 \\ 0 & 0 & s_3 & 0 \\ 0 & 0 & 0 & s_4 \end{bmatrix} \begin{bmatrix} B_{01} \\ B_{02} \\ B_{03} \\ B_{04} \end{bmatrix} \dots (15)$$

FIG. 23B

$$s_1 = 1 + k, \quad s_2 = \frac{1 + k}{1 - k}, \quad s_3 = \frac{1 + k}{1 - k}, \quad s_4 = 1 + k \quad \dots (16)$$

FIG. 24A $B_{oig1} = B_{01} + kB_{01} + k^2B_{01} + k^3B_{01} \dots (17)$

FIG. 24B $B_{oig1} = \frac{1}{1-k} B_{01} = (1+k) B_{01} \dots (18)$

FIG. 24C $B_{oig2} = kB_{02} + B_{02} + kB_{02} + k^2B_{02} \dots (19)$

FIG. 24D $B_{oig2} = \frac{kB_{02}}{1-k} + \frac{B_{02}}{1-k} = \frac{1+k}{1-k} B_{02} \dots (20)$

FIG. 25A

$$\begin{bmatrix} B_{oig11} & B_{oig12} & B_{oig13} & B_{oig14} \\ B_{oig21} & B_{oig22} & B_{oig23} & B_{oig24} \\ B_{oig31} & B_{oig32} & B_{oig33} & B_{oig34} \\ B_{oig41} & B_{oig42} & B_{oig43} & B_{oig44} \end{bmatrix} = \begin{bmatrix} s_1 & 0 & 0 & 0 \\ 0 & s_2 & 0 & 0 \\ 0 & 0 & s_3 & 0 \\ 0 & 0 & 0 & s_4 \end{bmatrix} \begin{bmatrix} B_{011} & B_{012} & B_{013} & B_{014} \\ B_{021} & B_{022} & B_{023} & B_{024} \\ B_{031} & B_{032} & B_{033} & B_{034} \\ B_{041} & B_{042} & B_{043} & B_{044} \end{bmatrix} \begin{bmatrix} t_1 & 0 & 0 & 0 \\ 0 & t_2 & 0 & 0 \\ 0 & 0 & t_3 & 0 \\ 0 & 0 & 0 & t_4 \end{bmatrix} \dots (21)$$

FIG. 25B

$$t_1 = 1 + m, \quad t_2 = \frac{1+m}{1-m}, \quad t_3 = \frac{1+m}{1-m}, \quad t_4 = 1 + m \quad \dots (22)$$

FIG. 26

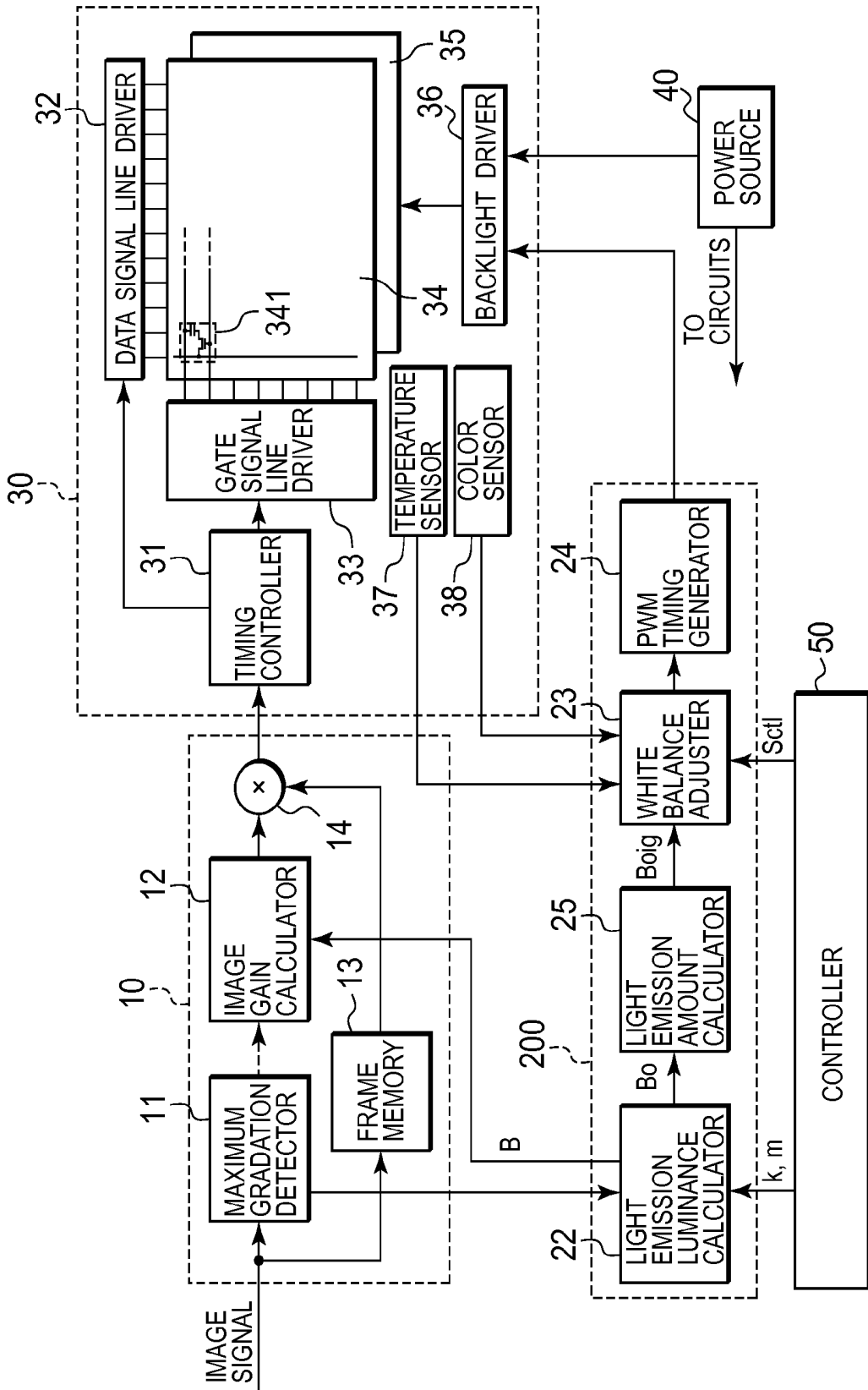

FIG. 27

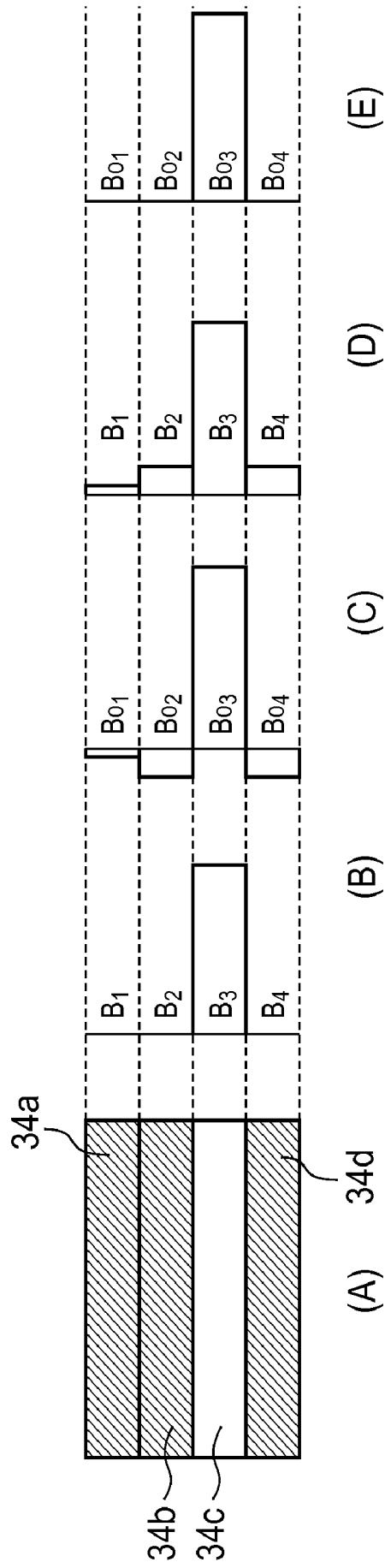

FIG. 28A $B_1 < k \times B_2, B_1 < k \times (B_{i-1} + B_{i+1}) / (1 + k^2), B_n < k \times B_{n-1} \dots (23)$

FIG. 28B $B_1 \geq k \times B_2, B_1 \geq k \times (B_{i-1} + B_{i+1}) / (1 + k^2), B_n \geq k \times B_{n-1} \dots (24)$

FIG. 28C $B_1 = k \times B_2, B_1 = k \times (B_{i-1} + B_{i+1}) / (1 + k^2), B_n = k \times B_{n-1} \dots (25)$

FIG. 29A $B_{1,j} < k \times B_{2,j}, B_{1,j} < k \times (B_{i-1,j} + B_{i+1,j}) / (1 + k^2), B_{n,j} < k \times B_{n-1,j} \dots (26)$

FIG. 29B $B_{1,j} \geq k \times B_{2,j}, B_{1,j} \geq k \times (B_{i-1,j} + B_{i+1,j}) / (1 + k^2), B_{n,j} \geq k \times B_{n-1,j} \dots (27)$

FIG. 29C $B_{1,j} = k \times B_{2,j}, B_{1,j} = k \times (B_{i-1,j} + B_{i+1,j}) / (1 + k^2), B_{n,j} = k \times B_{n-1,j} \dots (28)$

FIG. 29D $B_{i,1} < m \times B_{i,2}, B_{i,j} < m \times (A_{i,j-1} + A_{i,j+1}) / (1 + m^2), B_{i,n} < m \times B_{i,n-1} \dots (29)$

FIG. 29E $B_{i,1} \geq m \times B_{i,2}, B_{i,j} \geq m \times (A_{i,j-1} + A_{i,j+1}) / (1 + m^2), B_{i,n} \geq m \times B_{i,n-1} \dots (30)$

FIG. 29F $B_{i,1} = m \times B_{i,2}, B_{i,j} = m \times (A_{i,j-1} + A_{i,j+1}) / (1 + m^2), B_{i,n} = m \times B_{i,n-1} \dots (31)$

FIG. 30A

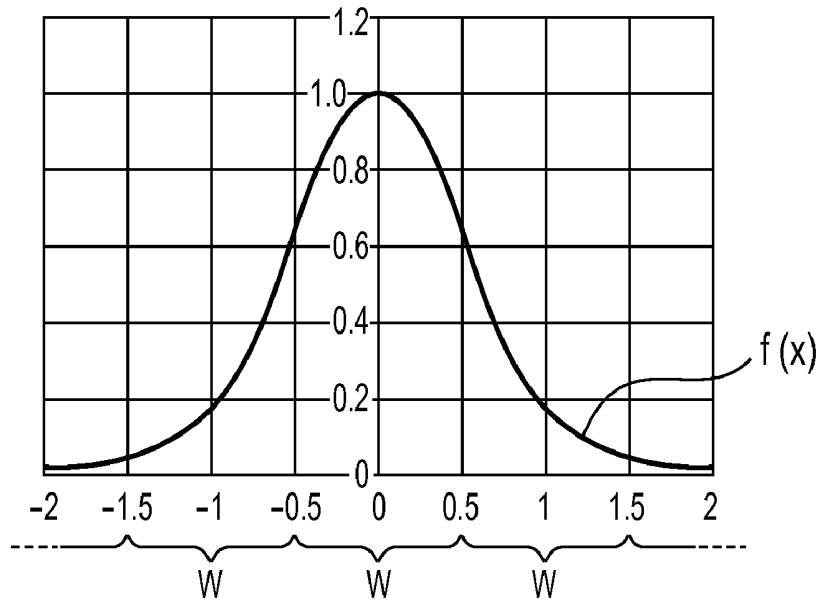

FIG. 30B

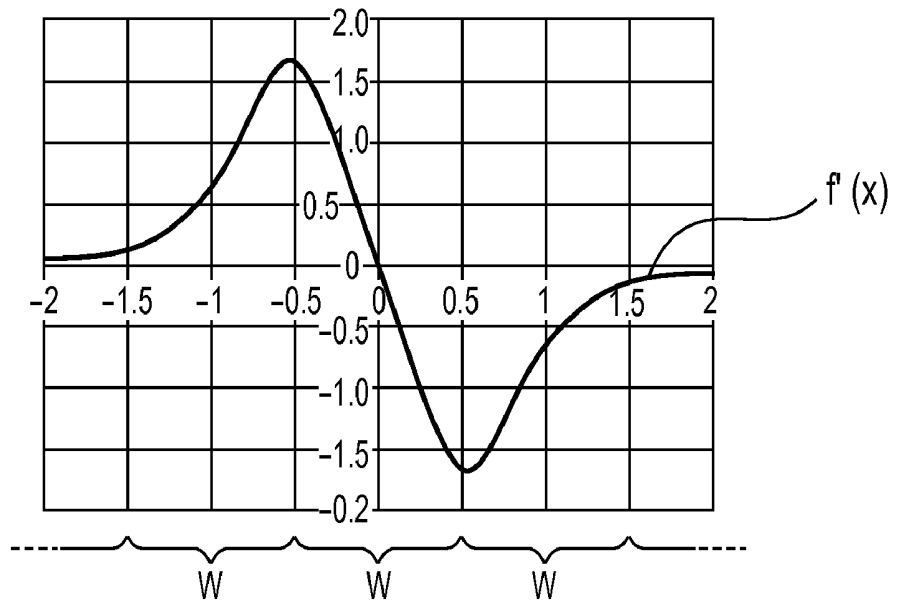

FIG. 31A

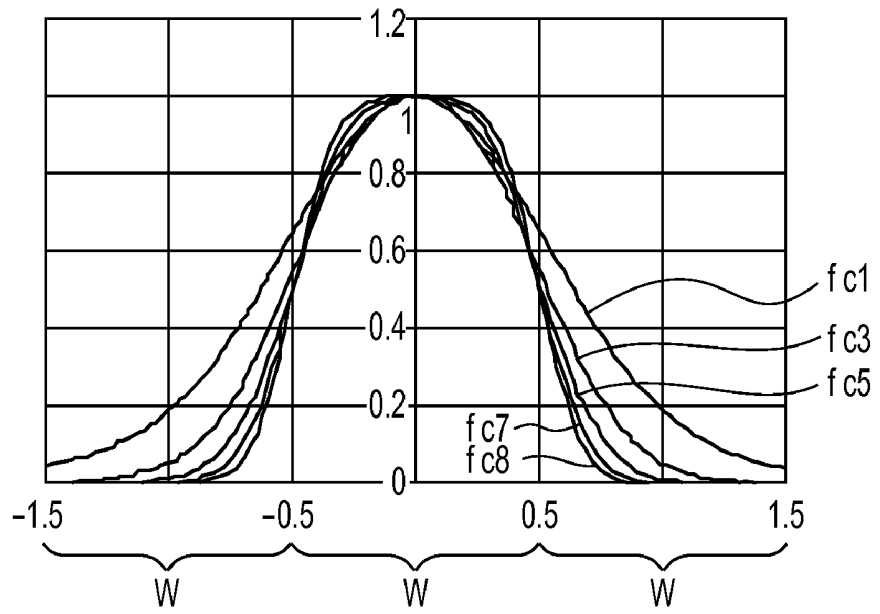

FIG. 31B

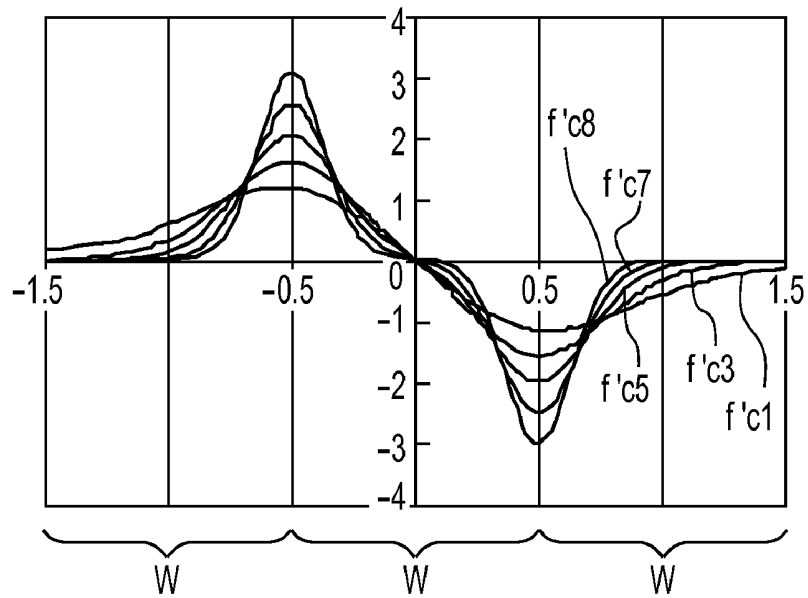

FIG. 32

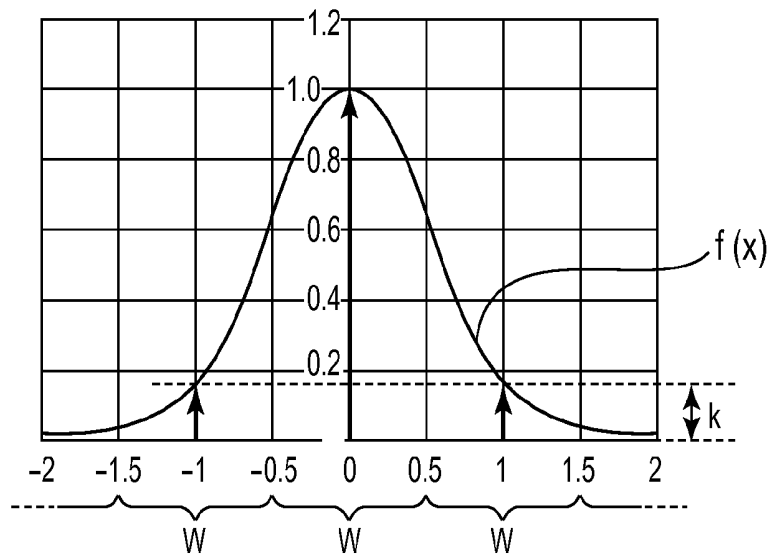

FIG. 33

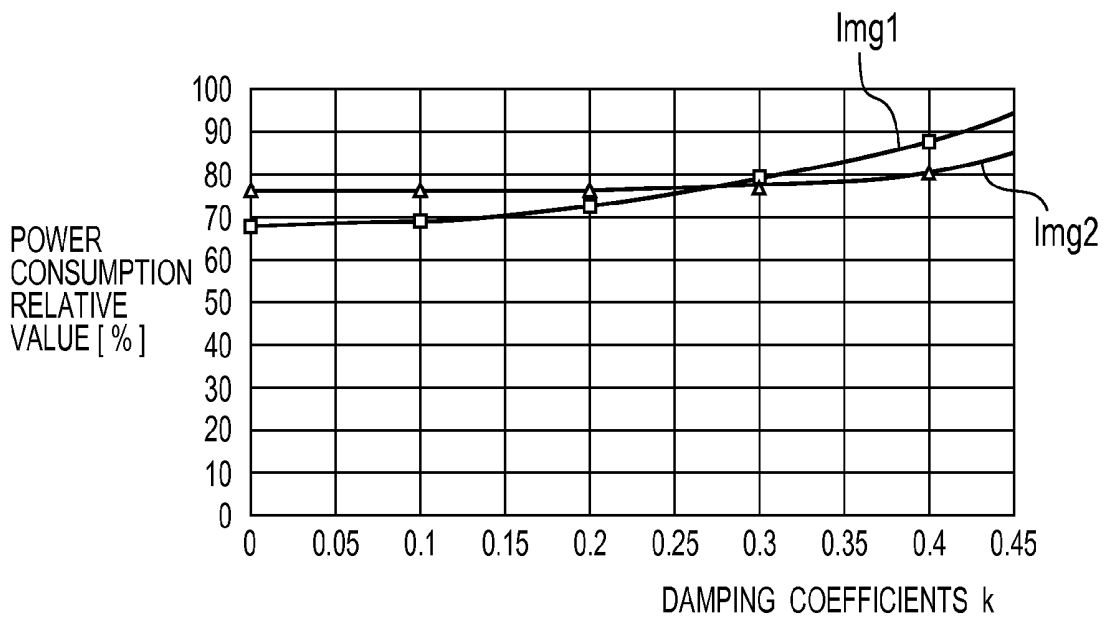

FIG. 34

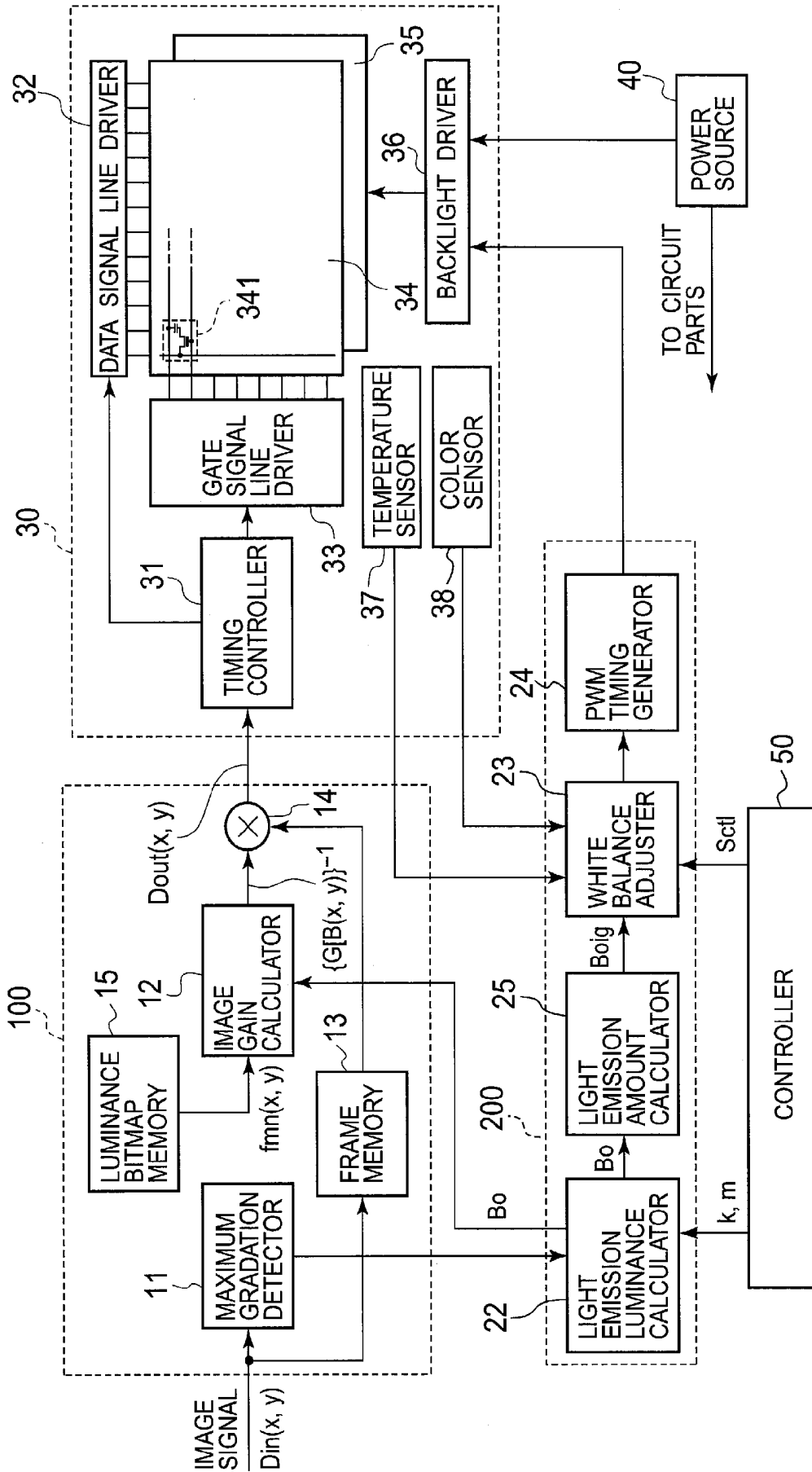

FIG. 35A $d_{out}(x, y) = \frac{G^{-1}[D_{in}(x, y)]}{B(x, y)} \dots (32)$

FIG. 35B $D_{out}(x, y) = G[d_{out}(x, y)] \dots (33)$

FIG. 35C $D_{out}(x, y) = D_{in}(x, y) \times \{G[B(x, y)]\}^{-1} \dots (34)$

FIG. 36

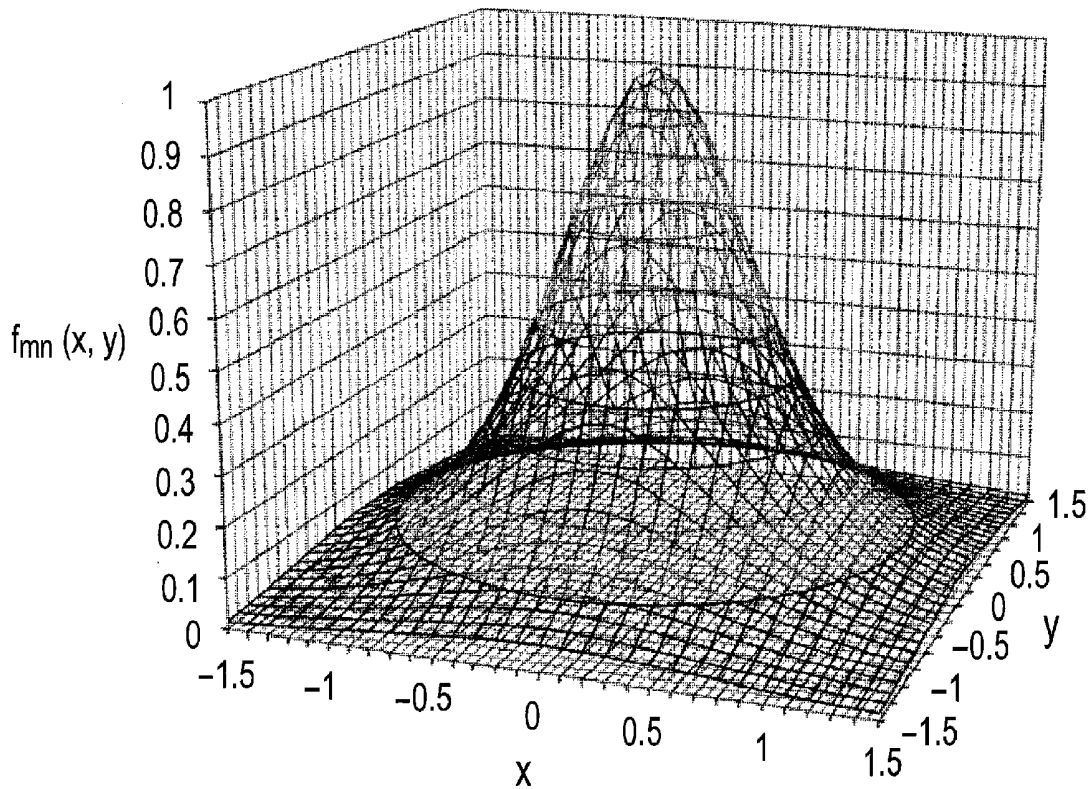

FIG. 37

$B(x, y) = \sum_m \sum_n \{B_{0mn} \times f_{mn}(x-x_{mn}, y-y_{mn})\} \dots (35)$

FIG. 38

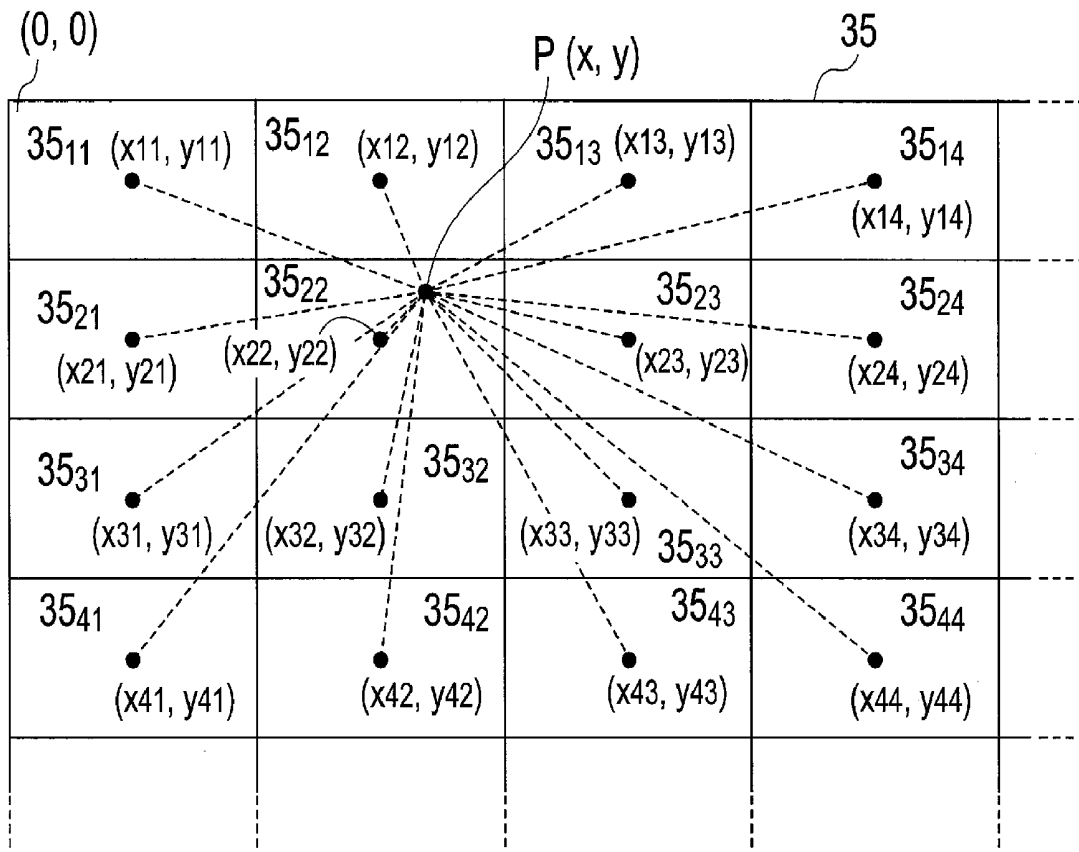

FIG. 39

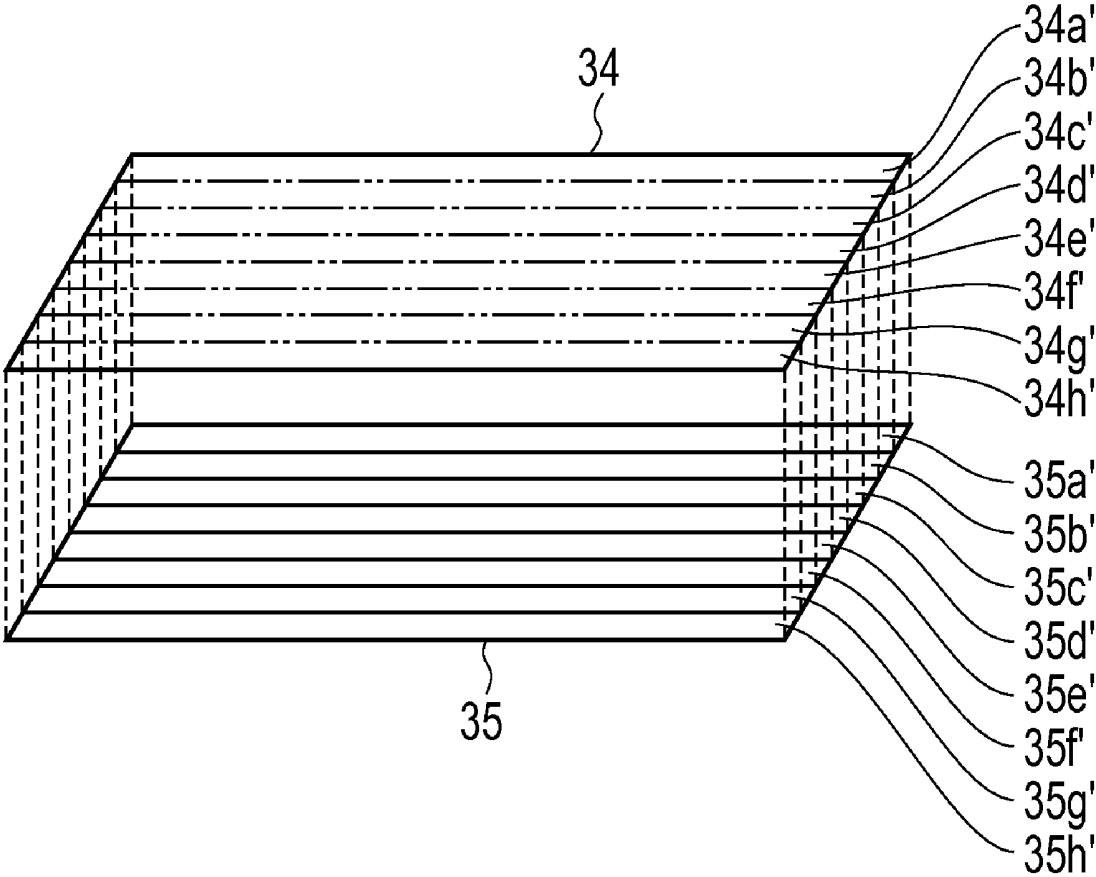

FIG. 40A

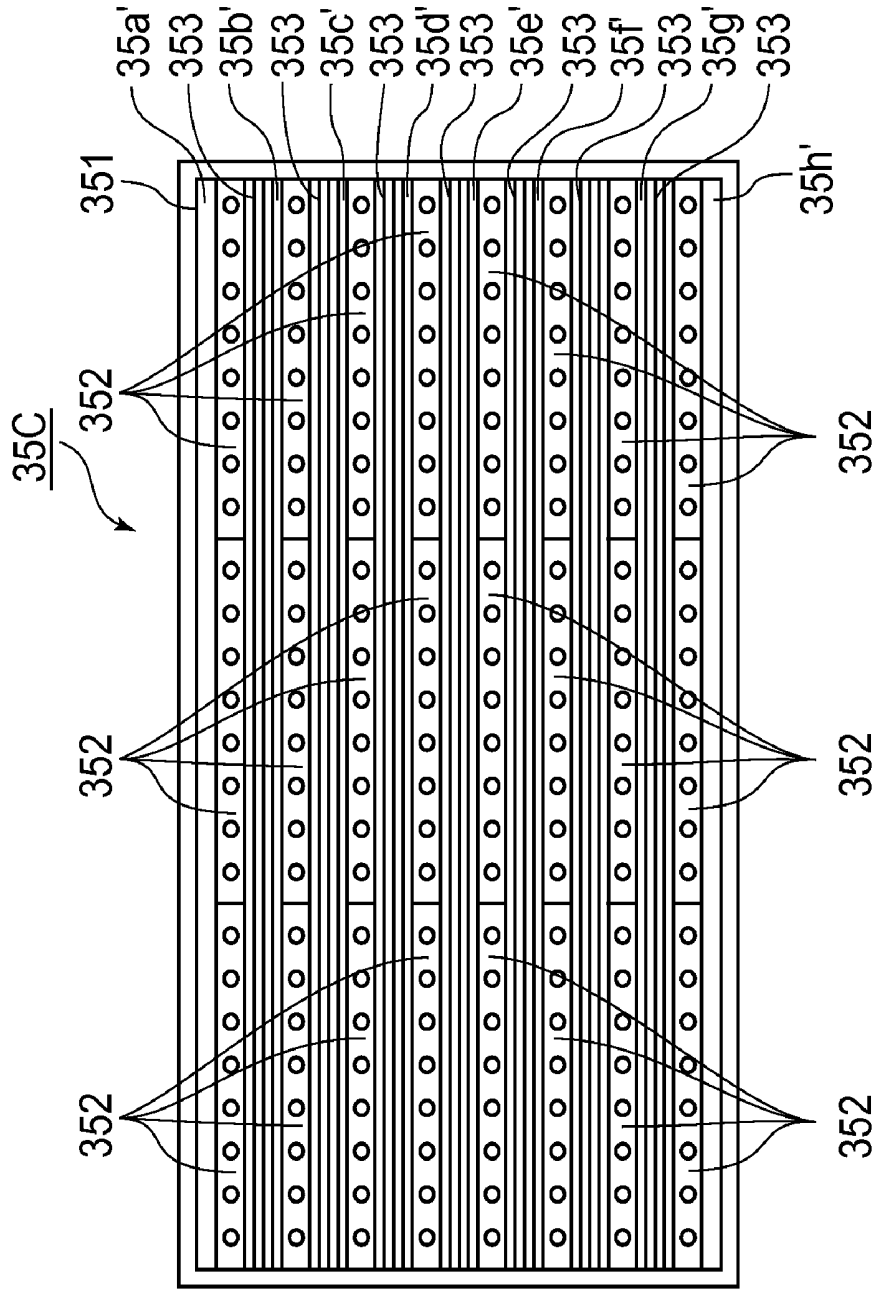

FIG. 40B

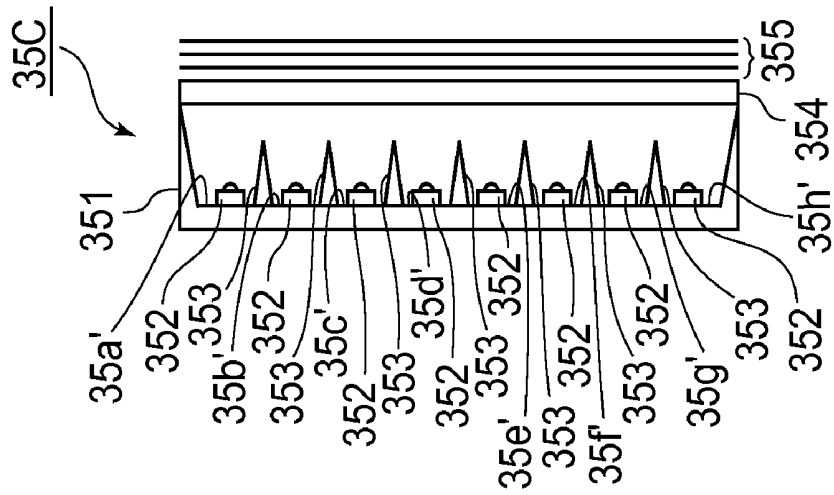

FIG. 41

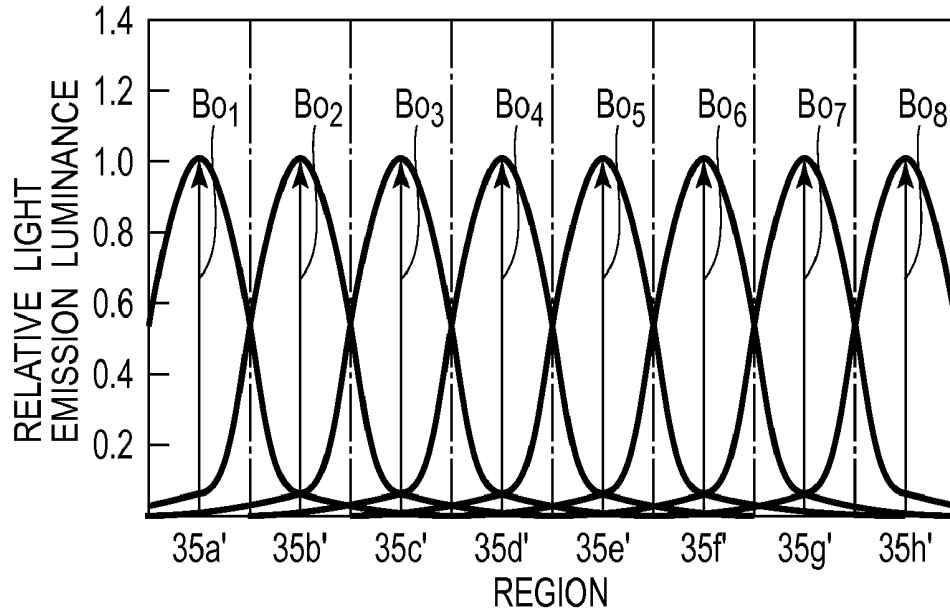

FIG. 42

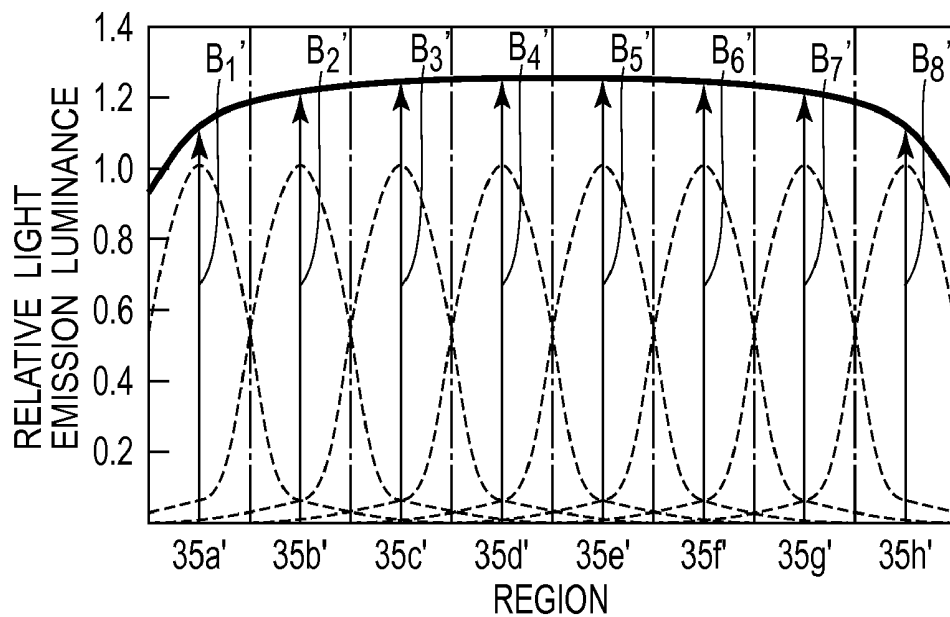

FIG. 43A

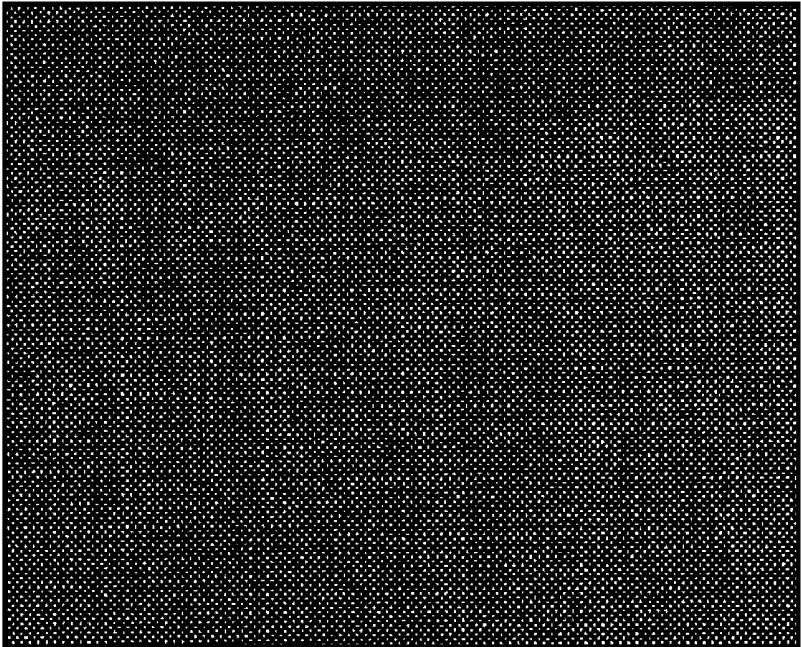

FIG. 43B

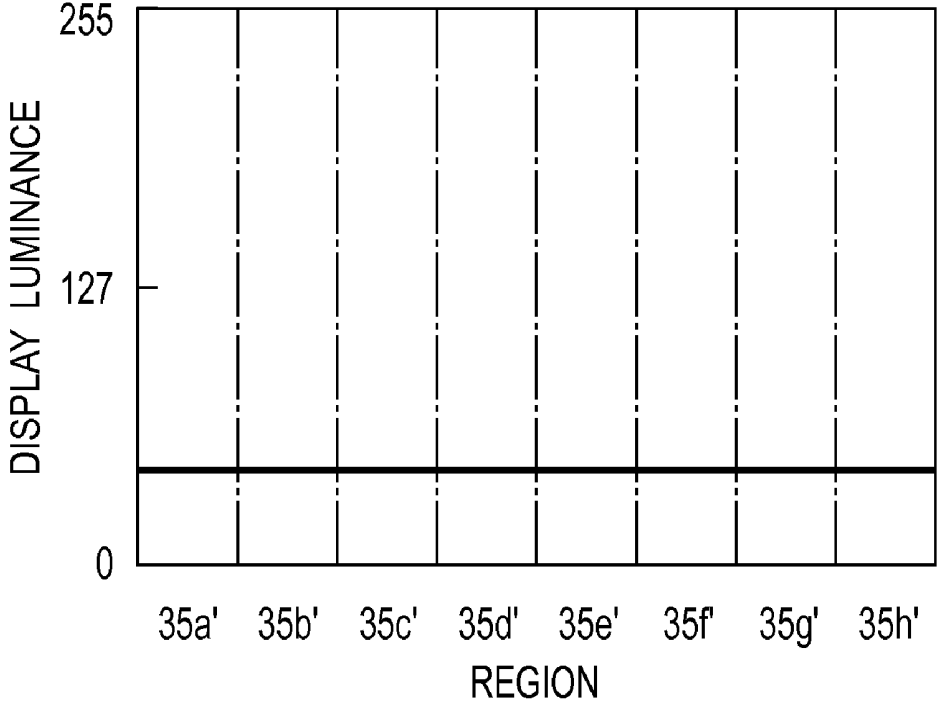

FIG. 44A

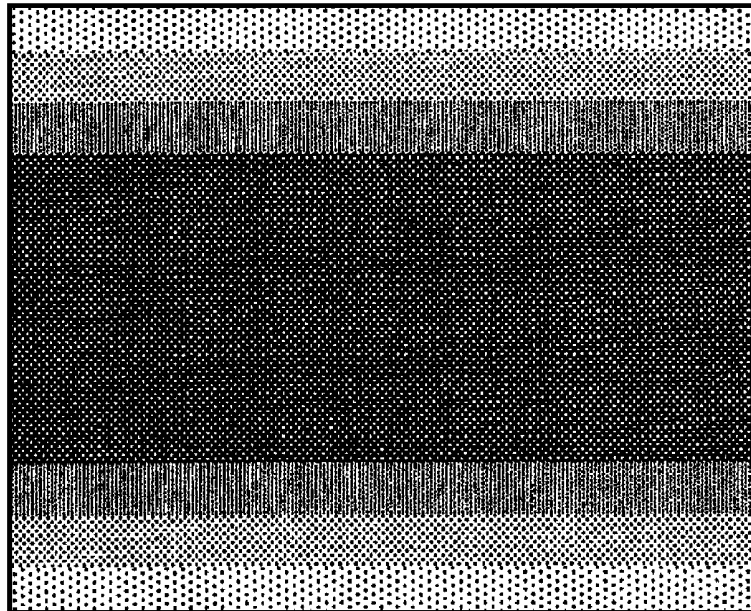

FIG. 44B

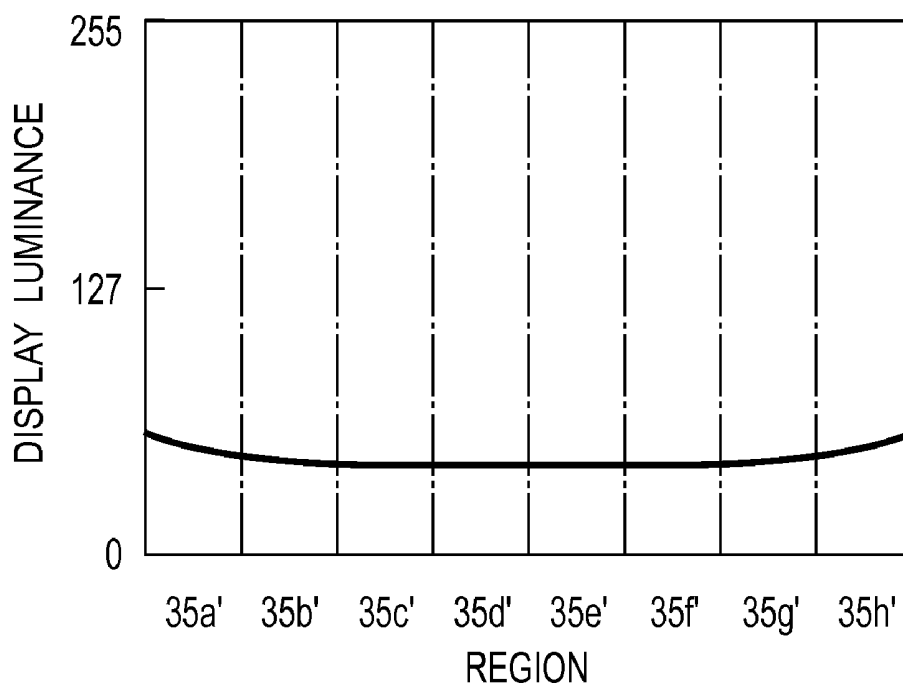

FIG. 45

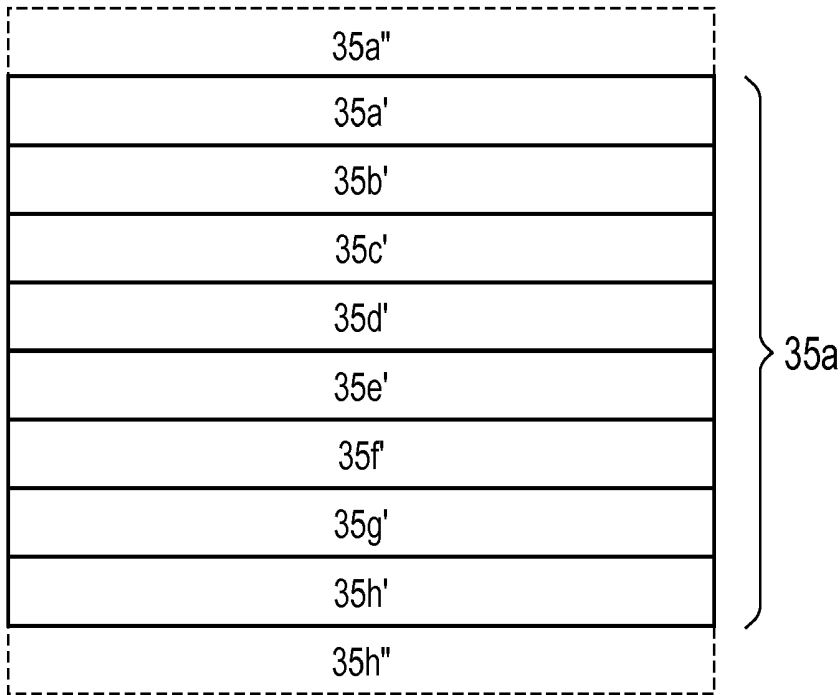

FIG. 46

$$\begin{bmatrix} B_0' \\ B_1' \\ B_2' \\ B_3' \\ B_4' \\ B_5' \\ B_6' \\ B_7' \\ B_8' \\ B_9' \end{bmatrix} = \begin{bmatrix} 1 & k & k^2 & k^3 & k^4 & k^5 & k^6 & k^7 & k^8 & k^9 \\ k & 1 & k & k^2 & k^3 & k^4 & k^5 & k^6 & k^7 & k^8 \\ k^2 & k & 1 & k & k^2 & k^3 & k^4 & k^5 & k^6 & k^7 \\ k^3 & k^2 & k & 1 & k & k^2 & k^3 & k^4 & k^5 & k^6 \\ k^4 & k^3 & k^2 & k & 1 & k & k^2 & k^3 & k^4 & k^5 \\ k^5 & k^4 & k^3 & k^2 & k & 1 & k & k^2 & k^3 & k^4 \\ k^6 & k^5 & k^4 & k^3 & k^2 & k & 1 & k & k^2 & k^3 \\ k^7 & k^6 & k^5 & k^4 & k^3 & k^2 & k & 1 & k & k^2 \\ k^8 & k^7 & k^6 & k^5 & k^4 & k^3 & k^2 & k & 1 & k \\ k^9 & k^8 & k^7 & k^6 & k^5 & k^4 & k^3 & k^2 & k & 1 \end{bmatrix} \begin{bmatrix} B_{00} \\ B_{01} \\ B_{02} \\ B_{03} \\ B_{04} \\ B_{05} \\ B_{06} \\ B_{07} \\ B_{08} \\ B_{09} \end{bmatrix} \dots (36)$$

FIG. 47

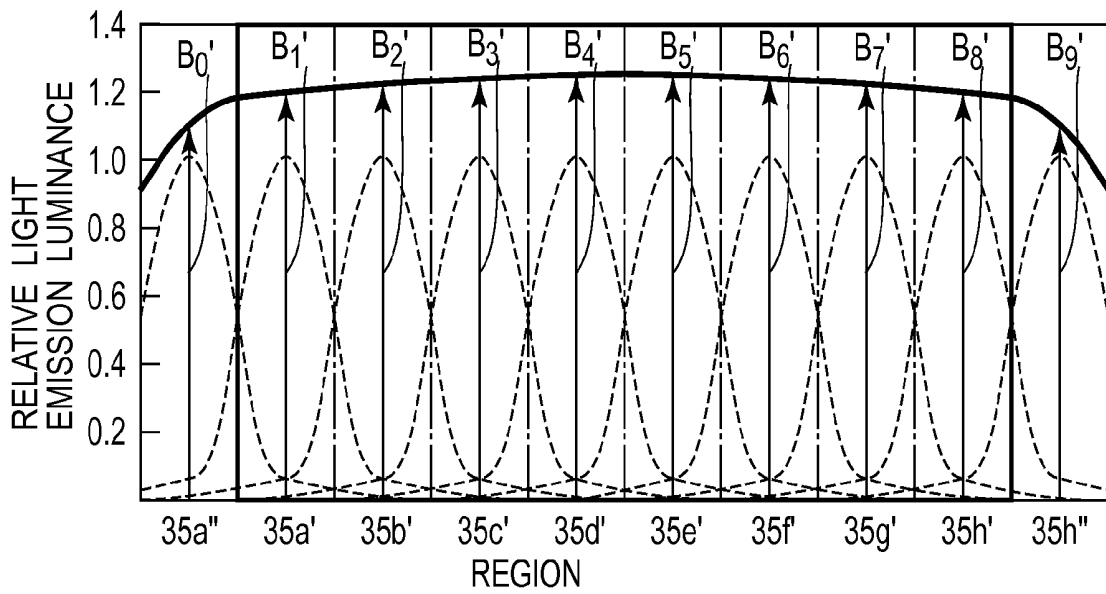

FIG. 48A

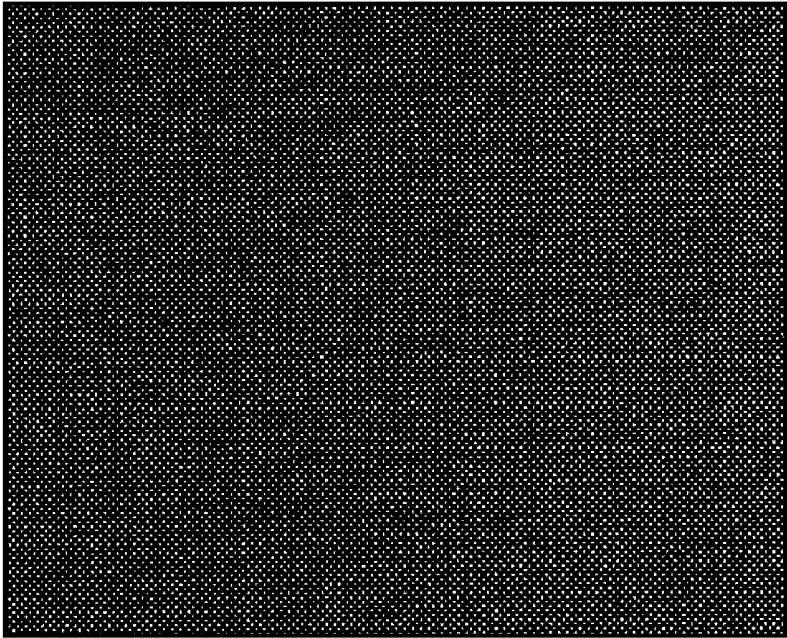

FIG. 48B

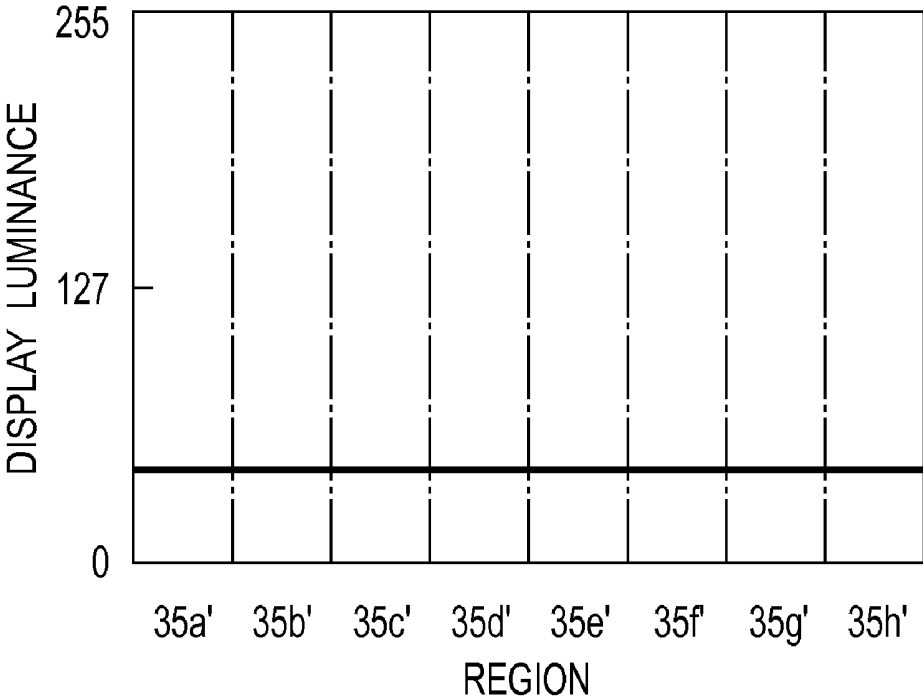

FIG. 49A

$$\begin{bmatrix} B_{00} \\ B_{01} \\ B_{02} \\ B_{03} \\ B_{04} \\ B_{05} \\ B_{06} \\ B_{07} \\ B_{08} \\ B_{09} \end{bmatrix} = \begin{bmatrix} 1 & k & k^2 & k^3 & k^4 & k^5 & k^6 & k^7 & k^8 & k^9 \\ k & 1 & k & k^2 & k^3 & k^4 & k^5 & k^6 & k^7 & k^8 \\ k^2 & k & 1 & k & k^2 & k^3 & k^4 & k^5 & k^6 & k^7 \\ k^3 & k^2 & k & 1 & k & k^2 & k^3 & k^4 & k^5 & k^6 \\ k^4 & k^3 & k^2 & k & 1 & k & k^2 & k^3 & k^4 & k^5 \\ k^5 & k^4 & k^3 & k^2 & k & 1 & k & k^2 & k^3 & k^4 \\ k^6 & k^5 & k^4 & k^3 & k^2 & k & 1 & k & k^2 & k^3 \\ k^7 & k^6 & k^5 & k^4 & k^3 & k^2 & k & 1 & k & k^2 \\ k^8 & k^7 & k^6 & k^5 & k^4 & k^3 & k^2 & k & 1 & k \\ k^9 & k^8 & k^7 & k^6 & k^5 & k^4 & k^3 & k^2 & k & 1 \end{bmatrix}^{-1} \begin{bmatrix} B_{0'} \\ B_{1'} \\ B_{2'} \\ B_{3'} \\ B_{4'} \\ B_{5'} \\ B_{6'} \\ B_{7'} \\ B_{8'} \\ B_{9'} \end{bmatrix} \dots (37)$$

FIG. 49B

$$\begin{bmatrix} B_{00} \\ B_{01} \\ B_{02} \\ B_{03} \\ B_{04} \\ B_{05} \\ B_{06} \\ B_{07} \\ B_{08} \\ B_{09} \end{bmatrix} = \begin{bmatrix} c & b & 0 & 0 & 0 & 0 & 0 & 0 & 0 & 0 \\ b & a & b & 0 & 0 & 0 & 0 & 0 & 0 & 0 \\ 0 & b & a & b & 0 & 0 & 0 & 0 & 0 & 0 \\ 0 & 0 & b & a & b & 0 & 0 & 0 & 0 & 0 \\ 0 & 0 & 0 & b & a & b & 0 & 0 & 0 & 0 \\ 0 & 0 & 0 & 0 & b & a & b & 0 & 0 & 0 \\ 0 & 0 & 0 & 0 & 0 & b & a & b & 0 & 0 \\ 0 & 0 & 0 & 0 & 0 & 0 & b & a & b & 0 \\ 0 & 0 & 0 & 0 & 0 & 0 & 0 & b & a & b \\ 0 & 0 & 0 & 0 & 0 & 0 & 0 & 0 & b & c \end{bmatrix} \begin{bmatrix} B_{0'} \\ B_{1'} \\ B_{2'} \\ B_{3'} \\ B_{4'} \\ B_{5'} \\ B_{6'} \\ B_{7'} \\ B_{8'} \\ B_{9'} \end{bmatrix} \dots (38)$$

FIG. 49C

$$a = \frac{1+k^2}{1-k^2} \cdot b = \frac{-k}{1-k^2} \cdot c = \frac{1}{1-k^2} \dots (39)$$

FIG. 50A

$$\begin{bmatrix} B_0' \\ B_1' \\ \vdots \\ \vdots \\ B_n' \\ B_{n+1}' \end{bmatrix} = \begin{bmatrix} 1 & k & \cdots & \cdots & k^{n-1} & k^n \\ k & 1 & \cdots & \cdots & k^{n-2} & k^{n-1} \\ \vdots & \vdots & \ddots & \ddots & \vdots & \vdots \\ \vdots & \vdots & \ddots & \ddots & \vdots & \vdots \\ k^{n-1} & k^{n-2} & \cdots & \cdots & 1 & k \\ k^n & k^{n-1} & \cdots & \cdots & k & 1 \end{bmatrix} \begin{bmatrix} B_{0_0} \\ B_{0_1} \\ \vdots \\ \vdots \\ B_{0_n} \\ B_{0_{n+1}} \end{bmatrix} \quad \dots (40)$$

FIG. 50B

$$\begin{bmatrix} B_{0_0} \\ B_{0_1} \\ \vdots \\ \vdots \\ B_{0_n} \\ B_{0_{n+1}} \end{bmatrix} = \begin{bmatrix} c & b & \cdots & \cdots & 0 & 0 \\ b & a & \cdots & \cdots & 0 & 0 \\ \vdots & \vdots & \ddots & \ddots & \vdots & \vdots \\ \vdots & \vdots & \ddots & \ddots & \vdots & \vdots \\ 0 & 0 & \cdots & \cdots & a & b \\ 0 & 0 & \cdots & \cdots & b & c \end{bmatrix} \begin{bmatrix} B_0' \\ B_1' \\ \vdots \\ \vdots \\ B_n' \\ B_{n+1}' \end{bmatrix} \quad \dots (41)$$

FIG. 52

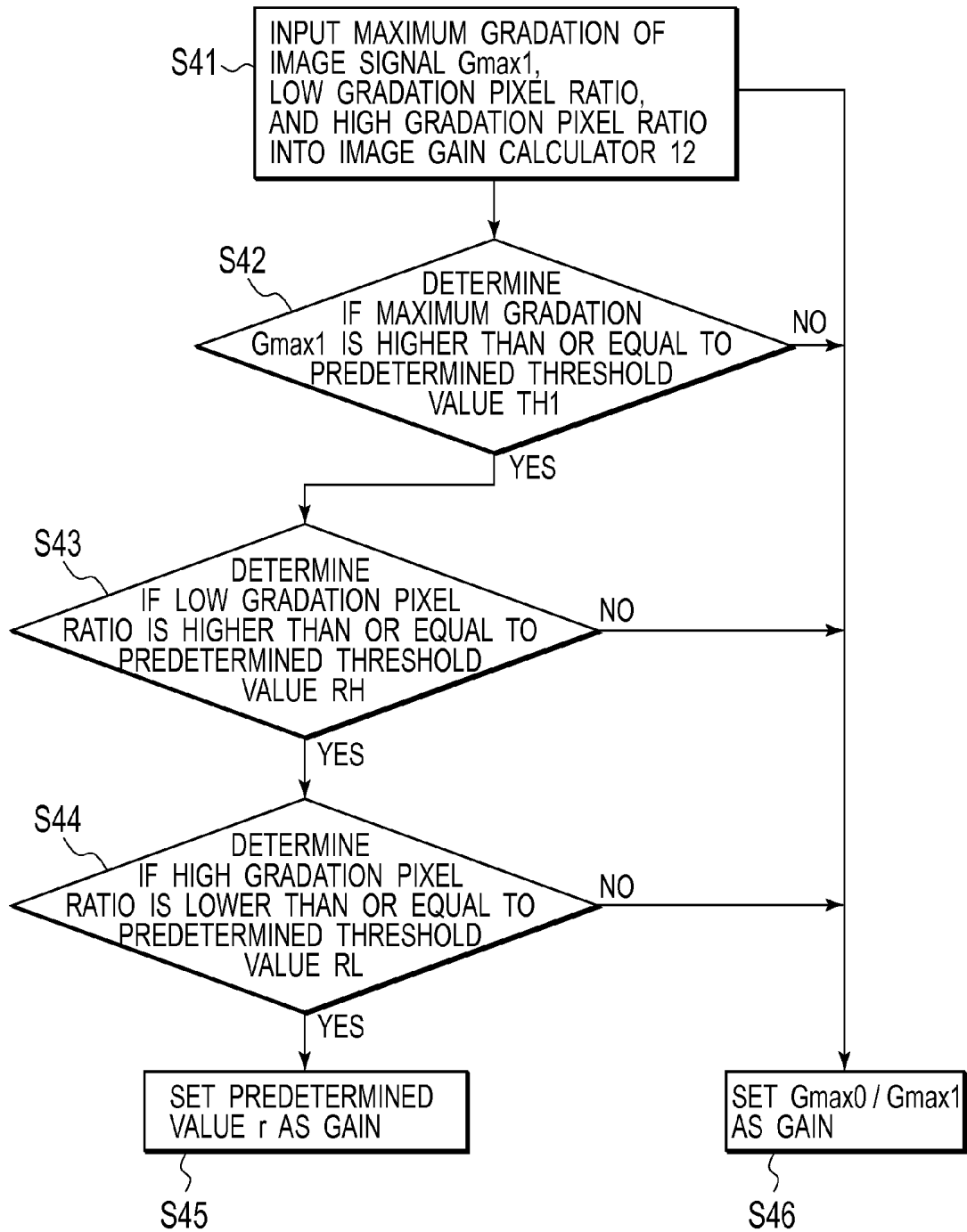

FIG. 53A

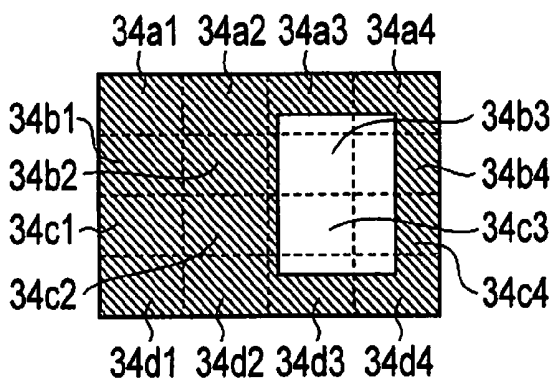

FIG. 53B

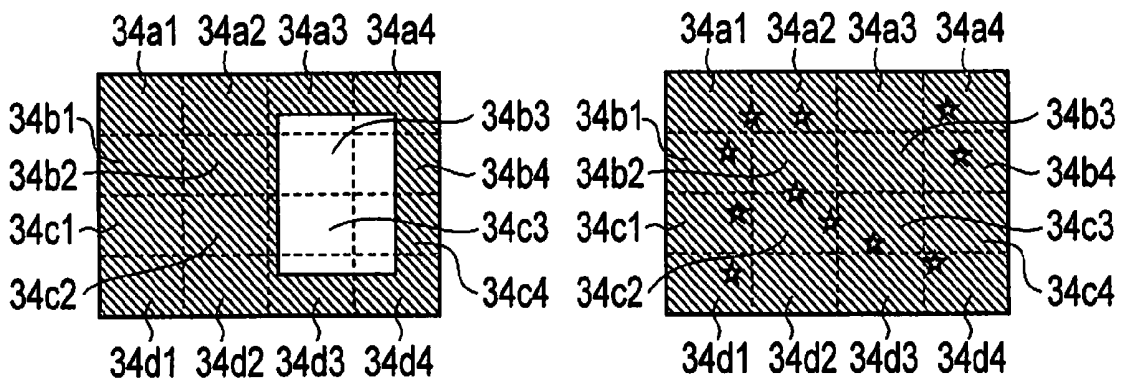

FIG. 53C

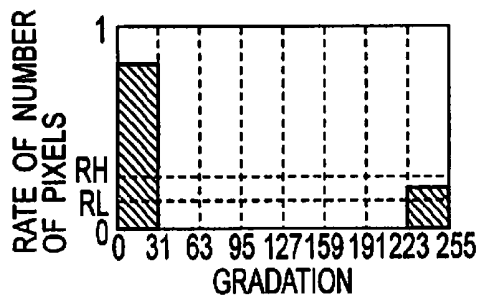

FIG. 53D

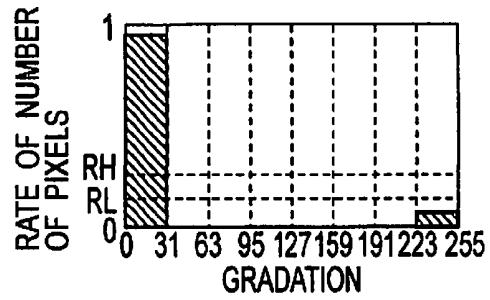

FIG. 54

$$r = C_0 \cdot \frac{R_b}{R_w} \quad \dots \quad (42)$$

LIQUID CRYSTAL DISPLAY DEVICE AND IMAGE DISPLAY METHOD THEREOF

CROSS REFERENCE TO RELATED APPLICATIONS

[0001] This application claims priority based on 35 USC 119 from prior Japanese Patent Application No. P2008-239039 filed on Sep. 18, 2008, entitled "LIQUID CRYSTAL DISPLAY DEVICE AND IMAGE DISPLAY METHOD THEREOF", the entire contents of which are incorporated herein by reference.

BACKGROUND OF THE INVENTION

[0002] 1. Field of the Invention

[0003] The present invention relates to a liquid crystal display device having a backlight device, and to an image display method for displaying an image signal while controlling light emission of the backlight device.

[0004] 2. Description of the Related Art

[0005] In a liquid crystal display device displaying an image using a liquid crystal panel, the liquid crystal panel itself does not emit light. Therefore, a backlight device is provided, for example, on the back of the liquid crystal panel. The liquid crystal in the panel is switched between an OFF state and an ON state according to applied voltage. When in the OFF state, the liquid crystal panel interrupts light, while, in the ON state, the liquid crystal panel transmits light. For this reason, the liquid crystal display device drives, as electric shutters, multiple pixels within the liquid crystal panel, by controlling the voltage applied to each of the multiple pixels. An image forms by this control of transmission of light from the backlight device through the panel.

[0006] A cold cathode tube (CCFL (cold cathode fluorescent lamp)) has heretofore been mainly used as a backlight in a backlight device. When using a CCFL in the backlight device, it is common to keep the CCFL at a certain constant lighting state regardless of the brightness of an image signal to be displayed by the liquid crystal panel.

[0007] A large share of power consumption by a conventional liquid crystal display device is for the backlight device. Therefore, a liquid crystal display device has a problem of needing a large power consumption in order to keep the backlight in the constant lighting state. For the purpose of solving this problem, various methods have been proposed wherein a light emitting diode (LED) is used as a backlight. The emission luminance of the LED changes according to the brightness of the image signal.

[0008] For examples of the letter, see the description of "T. Shirai, S. Shimizukawa, T. Shiga, and S. Mikoshiba, 44.4: RGB-LED Backlights for LCD-TVs with 0D, 1D, and 2D Adaptive Dimming, 1520 SID 06 DIGEST (Non-patent Document 1)" and Japanese Patent Application Laid-open Publications Nos. 2005-258403 (Patent Document 1), 2006-30588 (Patent Document 2) and 2006-145886 (Patent Document 3), which describe a backlight device including multiple LEDs that is divided into multiple regions. The emission luminance of the backlight for each region is controlled according to the brightness of the image signal. In particular, Non-patent Document 1 refers to this technique as "adaptive dimming."

[0009] In the related liquid crystal display device described in Non-patent Document 1, the multiple divided regions of the backlight device are each partitioned by a light shielding

wall. The emission luminance of each region is controlled entirely independently according to the image signal strength for each respective region. The LEDs vary in brightness and color, device by device, for their principal wavelength. The degree of such variation differs among colors of red (R), green (G) and blue (B). For this reason, when the multiple regions of the backlight device are completely separated from each other, the brightness and color varies among the regions. As a result, this produces the problem that an image displayed on the liquid crystal panel differs from an original image.

[0010] The brightness and light emission wavelength of an LED has a temperature dependence. In particular, an R LED emits less amounts of light with an increase in device temperature, and also experiences a large change of wavelength. In addition, the R, G and B devices have different properties in terms of age deterioration. For this reason, the foregoing problem is particularly acute due to change in temperatures of the LED devices and due to age deterioration of the LED devices.

[0011] In the configuration wherein the regions are completely separated from each other, it is difficult to determine the locations of adjacent regions of a particular pixel located above a boundary between the adjacent regions. This is because the manufacturing accuracy of the backlight device is far lower than that of the liquid crystal panel. For this reason, the configuration described in Non-patent Document 1 is not very useful.

[0012] In addition, as disclosed in non-patent document 1 and in patent documents 1 to 3, power consumption can be reduced by employing a configuration wherein a backlight device is divided into multiple regions, and in which the emission luminance of a backlight for each region is controlled according to the brightness of an image signal. Power consumption, however, is expected to be further reduced.

SUMMARY OF THE INVENTION

[0013] An aspect of the invention provides a liquid crystal display device that comprises: a liquid crystal panel configured to display an image from image signals; a backlight device disposed on the back side of the liquid crystal panel, and divided into a plurality of regions, the backlight device comprising light sources in each of the regions, wherein the light sources are positioned to emit light onto the liquid crystal panel; a histogram detector configured to detect an image signal gradation distribution for each region and to produce a histogram therefrom; an image gain calculator configured to calculate a gain from the detected gradation distribution of the histogram detector, and to control light emission from each light source in each region of the backlight device, and a light emission luminance calculator configured to control the light emission luminance of each light source based on a maximum luminance of the light sources and based on an inverse number of the gain calculated in the image gain calculator.

[0014] Another aspect of the invention provides an image display method that comprises: obtaining, as image signals for display on a liquid crystal panel, an image signal per each region of a first set on the liquid crystal panel; detecting a histogram of the gradation distribution of image signals per each region of the first set; calculating a gain based on the detected histogram, in order to control light emission luminance of a backlight device, the backlight device being divided into second set of regions corresponding to the first set of regions of the liquid crystal panel; displaying an image according to the image signal per region of the liquid crystal

panel while causing each light source in respective regions of the backlight device to emit light emission luminance based on a maximum luminance of the light sources and an inverse of the gain.

BRIEF DESCRIPTION OF THE DRAWINGS

[0015] FIG. 1 is a block diagram showing an entire configuration of a liquid crystal display device according to a first embodiment

[0016] FIG. 2 is a perspective view schematically showing the relationship between a region of liquid crystal panel 34 and a corresponding region of backlight device 35.

[0017] FIGS. 3A to 3D are graphs for describing a calculation process in which a gain is obtained by image gain calculator 12 shown in FIG. 1.

[0018] FIGS. 4A and 4B show a first configuration example of backlight device 35.

[0019] FIGS. 5A to 5C show a second configuration example of backlight device 35.

[0020] FIGS. 6A to 6D are plan views showing configuration examples of light source 352 of backlight device 35.

[0021] FIG. 7 is a diagram showing an example of a 2-dimensional region division of backlight device 35.

[0022] FIGS. 8A and 8B are graphs for describing a non-uniformization process in non-uniformization processor 21 shown in FIG. 1.

[0023] FIGS. 9A and 9B are views that describe leakage lights in each region of backlight device 35.

[0024] FIG. 10 is a diagram showing luminance of each light emitted from corresponding regions when each region of backlight device 35 is individually turned on.

[0025] FIGS. 11A to 11D show matrix equations used in the first to fourth embodiments when backlight device 35 is region-divided in one-dimension.

[0026] FIG. 12 shows a matrix equation used in the first to fourth embodiments when the backlight device 35 is region-divided in one dimension.

[0027] FIGS. 13A and 13B show matrix equations obtained by generalizing the matrix equations shown in FIGS. 11 and 12.

[0028] FIG. 14 is a diagram for describing leakage lights when the backlight device 35 is region-divided in two dimensions.

[0029] FIGS. 15A to 15D show matrix equations used in the first to fourth embodiments when the backlight device 35 is region-divided in two dimensions.

[0030] FIGS. 16A and 16B show matrix equations used in the first to fourth embodiments when the backlight device 35 is region-divided in two dimensions.

[0031] FIG. 17 shows a matrix equation obtained by generalizing the matrix equations shown in FIGS. 15 and 16.

[0032] FIG. 18 is a flowchart showing the operation of the liquid crystal display device and a procedure of the image display method according to the first embodiment.

[0033] FIG. 19 is a flowchart showing a modification example of the operation of the liquid crystal display device and a procedure of the image display method according to the first embodiment.

[0034] FIG. 20 is a flowchart showing another modification example of the operation of liquid crystal display device and a procedure of the image display method according to the first embodiment.

[0035] FIG. 21 is a block diagram showing an entire configuration of a liquid crystal display device according to a second embodiment.

[0036] FIG. 22 shows graphs for describing the second embodiment.

[0037] FIGS. 23A and 23B show matrix equations each for converting a light emission luminance of the light source into an amount of emitted light.

[0038] FIG. 24 shows equations for describing the matrix equations in FIGS. 23A and 23B.

[0039] FIGS. 25A and 25B show matrix equations each for converting a light emission luminance of the light source into an amount of emitted light.

[0040] FIG. 26 is a block diagram showing an entire configuration of a liquid crystal display device according to a third embodiment.

[0041] FIGS. 27A to 27E are diagrams for describing the third embodiment.

[0042] FIGS. 28A to 28C are expressions for describing the correction of a light emission luminance in the third embodiment.

[0043] FIGS. 29A to 29F are expressions for describing the correction of a light emission luminance in the third embodiment.

[0044] FIGS. 30A and 30B are characteristic charts for describing a liquid crystal display device according to a fourth embodiment.

[0045] FIGS. 31A and 31B are characteristic charts for describing the liquid crystal display device according to the fourth embodiment.

[0046] FIG. 32 is a characteristic chart for describing the liquid crystal display device according to the fourth embodiment.

[0047] FIG. 33 is a characteristic chart showing the relationship between an attenuation constant k and a relative value of power consumption in the liquid crystal display device according to the fourth embodiment.

[0048] FIG. 34 is a block diagram showing an entire configuration of a liquid crystal display device according to a fifth embodiment.

[0049] FIGS. 35A, 35B, and 35C show equations for describing the fifth embodiment.

[0050] FIG. 36 shows a three-dimensional graph describing characteristics of luminance bitmap held by the luminance bitmap memory 14 of FIG. 34.

[0051] FIG. 37 shows an equation for describing the fifth embodiment.

[0052] FIG. 38 is a diagram for describing the fifth embodiment.

[0053] FIG. 39 shows an example of divisions of regions in liquid crystal panel 34 and backlight device 35, while showing a schematic perspective view of a relationship between the regions of liquid crystal panel 34 and the regions of backlight device 35.

[0054] FIG. 40A is a top view of backlight device 35C. FIG. 40B is a sectional view showing a state in which backlight device 35C is vertically cut.

[0055] FIG. 41 is a view showing light emission luminances Bo_1 to Bo_8 of light right above light sources 352 in a horizontal direction without consideration of reflection at an end of backlight device 35, assuming that light sources 352 individually emit light in respective regions 35a' to 35h' into which backlight device 35 is divided in the vertical direction.

[0056] FIG. 42 is a view showing light emission luminances B_1' to B_8' of light emitted from regions $35a'$ to $35h'$ into which backlight device 35 is divided in the vertical direction.

[0057] FIG. 43A is a view showing an example of an image pattern when image signals with a uniform gradation are displayed on liquid crystal panel 34. FIG. 43B is a view showing the display luminance in one line of the image pattern shown in FIG. 43A.

[0058] FIG. 44A is a view showing an example of an image pattern on liquid crystal panel 34 when the image signals with a uniform gradation shown in FIG. 43A are inputted into image signal processor 10 (100) and the image signals are processed based on the light emission luminances of backlight device 35 shown in FIG. 42. FIG. 44B is a view showing the display luminance in one line of the image pattern shown in FIG. 44A.

[0059] FIG. 45 is a view that explains virtual region $35a''$ and virtual region $35h''$.

[0060] FIG. 46 shows a matrix equation for obtaining light emission luminances B_0' to B_9' from light emission luminances Bo_1 to Bo_9 right above light sources 352 when respective light sources 352 in regions $35a'$ to $35h'$ emit light individually.

[0061] FIG. 47 is a view showing light emission luminances B_0' to B_9' of light emitted from regions $35a'$ to $35h'$ into which backlight device 35C is divided in the vertical direction.

[0062] FIGS. 48A and 48B show an image pattern and display luminance in one line of the image pattern.

[0063] FIG. 49A shows a matrix equation (37) for obtaining light emission luminances Bo_0 to Bo_9 from light emission luminances B_0' to B_9' . FIG. 49B shows a matrix equation (38) obtained by rearranging Eq. (37) to make it easy to perform a calculation in a circuit of light emission luminance calculator 22. FIG. 49C shows constants a, b, and c.

[0064] FIG. 50A shows a matrix equation (40) for obtaining light emission luminances B_0' to B_{n+1}' . FIG. 50B shows a matrix equation (41) for obtaining light emission luminances Bo_0 to Bo_{n+1} .

[0065] FIG. 51 is a block diagram showing an entire configuration of a liquid crystal display device according to a seventh embodiment.

[0066] FIG. 52 is a flowchart showing an operation of the histogram detector and steps obtaining a gain according to the seventh embodiment.

[0067] FIGS. 53A and 53B are both examples of image patterns, FIG. 53C indicates the histogram obtained from the image pattern in the region of $34d4$ in FIG. 53A, and FIG. 53D indicates the histogram obtained by the image pattern in the region of $34d4$ in FIG. 53B.

[0068] FIG. 54 shows an equation for obtaining a gain to control image signals and a backlight

tion, the drawings include parts whose dimensional relationship and ratios are different from one drawing to another.

First Embodiment

[0070] A liquid crystal display device of a first embodiment and an image display method to be used in this device will be described below with reference to the accompanying drawings. FIG. 1 is a block diagram showing an entire configuration of the liquid crystal display device of the first embodiment. In FIG. 1, an image signal to be displayed on liquid crystal panel 34 in liquid module unit 30, which will be described later, is supplied to a maximum gradation detector 11 and frame memory 13 in image signal processor 10. As will be described later in detail, backlight device 35 is divided into a plurality of regions, and liquid crystal panel 34 is divided into a plurality of regions so that these divided regions, respectively, correspond to the divided regions of backlight device 35, whereby luminance of the backlight (amount of light) is controlled in every region of liquid crystal panel 34.

[0071] FIG. 2 is a view showing an example of region divisions of liquid crystal panel 34 and of backlight device 35, while showing a schematic perspective view of a relationship between regions of liquid crystal panel 34 and regions of backlight device 35. As readily understood, liquid crystal panel 34 and backlight device 35 are arranged so that liquid crystal panel 34 and backlight device 35 are spaced away from each other. As shown in FIG. 2, backlight device 35 is divided in regions $35a$ to $35d$, and each of regions $35a$ to $35d$ have backlights, respectively. Liquid crystal panel 34 includes a plurality of pixels consisting of, for example, 1920 pixels in the horizontal direction, and 1080 pixels in the vertical direction. Liquid crystal panel 34 has a plurality of pixels divided into regions $34a$ to $34d$ so that these regions $34a$ to $34d$ can correspond to regions $35a$ to $35d$ of backlight device 35. In this example, since liquid crystal panel 34 is one-dimensionally divided into four regions, i.e., regions $34a$ to $34d$, in a vertical direction, one region contains 270 pixels in the vertical direction. However, the pixels, concluded in each of four regions $34a$ to $34d$, may naturally be scattered in the vertical direction.

[0072] Liquid crystal panel 34 is not physically divided into regions $34a$ to $34d$, but multiple regions (here, regions $34a$ to $34d$) are set on liquid crystal panel 34. Image signals to be supplied to liquid crystal panel 34 correspond to multiple regions set on liquid crystal panel 34, and processed as image signals for respective regions, which are respectively displayed on the plurality of regions. Image signals, which are supplied to liquid crystal panel 34, are processed as respective image signals corresponding to the multiple regions, which are to be displayed on the multiple regions set on liquid crystal panel 34. For each multiple region set on liquid crystal panel 34, the luminances of the backlights are individually controlled.

[0073] In the example shown in FIG. 2, liquid crystal panel 34 is vertically divided into four regions. In accordance with the divisions of liquid crystal panel 34, backlight device 35 also is vertically divided into four regions. These regions may be further divided (sectioned). Further, as will be described later, liquid crystal panel 34 is divided in both vertical and horizontal directions. Corresponding to this division, backlight device 35 also maybe divided in both vertical and horizontal directions. Preferably the number of divided (sectioned) regions are larger and partitioning (sectioning) in both

DETAILED DESCRIPTION OF EMBODIMENTS

[0069] Descriptions are provided hereinbelow for embodiments based on the drawings. In the respective drawings referenced herein, the same constituents are designated by the same reference numerals and duplicate explanation concerning the same constituents is basically omitted. All of the drawings are provided to illustrate the respective examples only. No dimensional proportions in the drawings shall impose a restriction on the embodiments. For this reason, specific dimensions and the like should be interpreted with the following descriptions taken into consideration. In addition,

vertical and horizontal directions is better than partitioning (zoning) in the horizontal direction only. Here, for the sake of simplicity, the operation of FIG. 1 is described, with four vertically divided regions shown in FIG. 2 as an example.

[0074] Returning back to FIG. 1, with respect to every frame of an image signal, maximum gradation detector 11 detects maximum gradations of each image signal displayed on respective regions 34a to 34d of liquid crystal panel 34. Preferably a maximum gradation is detected for every frame of an image signal, but a maximum gradation may be detected for every two frame depending on circumstances. In either case, the detector may detect the maximum gradation for every unit of time determined in advance. Each data point, which represents a maximum gradation on regions 34a to 34d as detected by maximum gradation detector 11, is supplied to gain calculator 12 and non-uniformization processor 21. Calculator 12 within image signal processor 10 and processor 21 is within backlight luminance controller 20. Image gain calculator 12 calculates a gain, by which image signals to be displayed on regions 34a to 34d are multiplied, in the following manner.

[0075] FIGS. 3A to 3D describe a gain calculation process which is operated in the image gain calculator 12. For every image signal supplied to each of regions 34a to 34d of liquid crystal panel 34, a gain to be multiplied to an image signal is obtained. Accordingly, a gain calculation, as described below, is performed on each image signal supplied to regions 34a to 34d. Note that in FIGS. 3A to 3D, an input signal (image signal) indicated on the horizontal axis is represented in 8-bit, 0 to 255 gradation. In addition, display luminance (display gradation) of liquid crystal panel 34 indicated on the vertical axis takes a value from 0 to 255 for the sake of simplicity, without consideration of transmissivity of liquid crystal panel 34. Bit number of the image signal is not limited to 8-bits, but may be for example, 10-bits.

[0076] A curve Cv1 in FIG. 3A shows how display luminance for an image signal having gradation of 0 to 255 is presented on liquid crystal panel 34. With the horizontal axis denoted by x and the vertical axis denoted by y, curve Cv1 is represented by a curve in which y is a function of x to the power of 2.2 to 2.4. This curve usually is referred to as a gamma curve with a gamma of 2.2 to 2.4. The curve in FIG. 3A may not be represented by the gamma curve Cv1, according to the kind of the liquid crystal panel 34.

[0077] Now, as an example, assume that maximum gradation is 127, and an input signal takes a gradation from 0 to 127 as shown in FIG. 3B. The display luminance of liquid crystal panel 34 for this case is represented by curve Cv2 with the value of the display luminance from 0 to 56. At this time, it is assumed that a backlight emits light at the gradation of the maximum luminance, 255. The maximum luminance of a backlight is the luminance at which the backlight emits light when an image signal has the maximum gradation 255 (i.e., white). When multiplying a gain of approximately 4.5 to an image signal as indicated by the curve Cv2 of FIG. 3B, the result becomes curve Cv3 indicated in FIG. 3C. The gain of approximately 4.5 is obtained from 255/56. Even also for a state of FIG. 3C, it is assumed that the backlight emits light at a maximum luminance.

[0078] In this state, an image signal having characteristics indicated by curve Cv3 differs from an initial signal having characteristics indicated by curve Cv2 of FIG. 3B. In addition, backlights consume unnecessary power. Accordingly, the light emission luminance of the backlights is set to

approximately 1/4.5 of the maximum luminance, so that the curve Cv3, with a display luminance of 0 to 255 can become curve Cv4 with display luminance of 0 to 56. Thus, an image signal having characteristics indicated by the curve Cv4 substantially becomes equivalent to that having characteristics indicated by curve Cv2, and power consumption of the backlights is reduced.

[0079] To be more precise, here, assume that Gmax1 denotes a maximum gradation of an image signal displayed on each of regions 34a to 34d within one frame period, and that Gmax0 denotes a possible maximum gradation of the image signal. The achievable maximum gradation is determined according to the number of bits of image signals. Then, image gain calculator 12 sets Gmax0/Gmax1 for each of regions 34a to 34d as a gain to be multiplied to an image signal being displayed on each of regions 34a to 34d. Gmax1/Gmax0, which is an inverse number of the gain Gmax0/Gmax1, is used to control luminance of the backlights in backlight luminance controller 20. When picture patterns of image signals to be displayed on regions 34a to 34d differ from each other, maximum gradations Gmax1 of the respective regions 34a to 34d inevitably differ from each other. Accordingly, Gmax0/Gmax1 varies for each one of regions 34a to 34d. The configuration and operation of backlight luminance controller 20 will be described in detail later.

[0080] In FIG. 1, a gain for each one of regions 34a to 34d calculated by image gain calculator 12 is inputted into multiplier 14. Multiplier 14 multiplies gains respectively to image signals being outputted from frame memory 13, and outputs the multiplied image signals for display on regions 34a to 34d.

[0081] Image signals outputted from multiplier 14 are supplied to timing controller 31 in liquid module unit 30. Liquid crystal panel 34 includes multiple pixels 341 as previously described.

[0082] Data signal line driver 32 is connected to data signal lines of pixels 341, and gate signal line driver 33 is connected to gate signal lines. An image signal inputted to timing controller 31 is supplied to data signal line driver 32. Timing controller 31 controls timings at which image signals are written on liquid crystal panel 34, by data signal line driver 32 and gate signal line driver 33. Pixel data constituting respective lines of image signals inputted in data signal line driver 32 are written in sequence in pixels of respective lines one by one through the driving of the gate signal lines by gate signal line driver 33. Thus, respective frames of image signals are displayed on liquid crystal panel 34 in sequence.

[0083] Backlight device 35 is disposed on the back side of liquid crystal panel 34. A direct-type backlight device and/or a light-guiding plate type backlight device may be used as backlight device 35. The direct-type backlight device is disposed directly below liquid crystal panel 34. In the case for the light-guiding plate type backlight device, light emitted from a backlight is made incident onto a light-guiding plate so as to irradiate liquid crystal panel 34. Backlight device 35 is driven by backlight driver 36. To backlight driver 36, power is supplied from power source 40 to cause the backlight to emit light. Incidentally, power source 40 supplies power to circuits which need power. Liquid module unit 30 includes temperature sensor 37, which detects the temperature of backlight device 35, and color sensor 38, which detects the color temperature of light emitted from backlight device 35.

[0084] A specific configuration example of backlight device 35 next is described. FIG. 4 is a view showing an

embodiment wherein backlight device **35** is divided into four regions along the longitudinal to vertical directions. Hereinafter, a first configuration example of backlight device **35** shown in FIG. **4** is referred to as backlight device **35A**, and a second configuration example of backlight device **35** shown in FIG. **5** is referred to as backlight device **35B** as will be described later. Backlight device **35** is a collective term for backlight device **35A**, backlight device **35B** and other configuration. FIG. **4A** is a top view of backlight device **35A**, and FIG. **4B** is a sectional view showing a state in which backlight device **35A** is vertically cut.

[0085] As shown in FIGS. **4A** and **4B**, backlight device **35A** has a configuration in which light source **352** for the backlight is horizontally arranged in and attached to rectangular housing **351** having a predetermined depth. Light source **352** is, for example, an LED. Backlight device **35A** is divided into regions **35a** to **35d** with partition walls **353**. Partition walls **353** protrude from the bottom surface of housing **351** to the predetermined portion higher than the uppermost surface (vertexes) of light sources **352**. Inner sides of housing **351** and surfaces of partition wall **353** are covered with reflective sheets.

[0086] Diffusion plate **354** diffusing light is mounted on an upper part of housing **351**. Three optical sheets and their like **355** are mounted on diffusion plate **354** for example. Optical sheets and their like **355** are formed by combining multiple sheets such as a diffusion sheet, a prism sheet, and a brightness enhancement film, which is referred to as a DBEF (Dual Brightness Enhancement Film). Each top surface of partition walls **353**, covered with reflective sheet, does not reach diffusion plate **354**, so that regions **35a** to **35d** are not separated, and are not completely independent from each other. That is, backlight device **35A** has a structure in which light emission from each light source **352** of regions **35a** to **35d** is allowed to leak to other regions. As described later, in the first embodiment, the amount of light leaked from regions **35a** to **35d** to other regions is considered, allowing control of the luminances of the lights emitted from regions **35a** to **35d**.

[0087] FIG. **5** is a view showing backlight device **35B**, which is a second configuration example of backlight device **35** in the case where liquid crystal panel **34** is divided into four regions in the vertical direction and, further, divided into four regions in the horizontal direction, i.e., in the case where liquid crystal panel **34** is divided into sixteen regions in two dimension. FIG. **5A** is a top view of backlight device **35B**; FIG. **5B** is a sectional view showing backlight device **35B** cut in the vertical direction. FIG. **5C** is a sectional view showing backlight device **35B** cut in the horizontal direction. Here, FIG. **5B** shows backlight device **35B** cut along the left-end partition wall in FIG. **5A**. FIG. **5C** shows backlight device **35B** cut along the top-end partition wall in FIG. **5A**.

[0088] In FIGS. **4A** to **4B**, and FIGS. **5A** to **5C**, identical reference numerals indicate identical components, so that a description thereof will be omitted as appropriate.

[0089] Housing **351** is divided into sixteen regions, regions **35a1** to **35a4**, **35b1** to **35b4**, **35c1** to **35c4**, and **35d1** to **35d4**, with partition walls **353** in the horizontal and vertical directions. Backlight device **35B** has a structure in which light emits from each of light sources **352** in regions **35a1** to **35a4**, **35b1** to **35b4**, **35c1** to **35c4**, and **35d1** to **35d4** and is allowed to leak to other regions. In the first embodiment, the amount of light leakage from respective regions **35a1** to **35a4**, **35b1** to **35b4**, **35c1** to **35c4**, and **35d1** to **35d4** to other regions is

considered so that luminances of light from regions **35a1** to **35a4**, **35b1** to **35b4**, **35c1** to **35c4**, and **35d1** to **35d4** are controlled.

[0090] A LED is a highly directional light source. Accordingly, when a LED is used for light source **352**, the heights of partition walls **353** covered with reflective sheets may be lower than that shown in FIGS. **4** and **5**, and may be removed depending on the situation. Dome-like lenses may cover elements of light sources **352** so that the same effects can occur as that caused by partition walls **353**. Further, light sources other than LEDs, such as CCFLs and external electrode fluorescent lamps (EEFLs) may be used as light sources for the backlight. However, an LED is still preferable as light source **352** in the first embodiment since it is easy to control light emission luminance and the light emitting area thereof. The specific configuration of backlight device **35** is not limited to those shown in FIGS. **4** and **5**.

[0091] More specifically, light sources **352** shown in FIGS. **4** and **5** are configured as follows. In a first configuration example light sources **352** shown in FIG. **6A**, LED **357G** of G, LED **357R** of R, LED **357B** of B, and LED **357G** of G are mounted on substrate **356** in this order. Substrate **356** is, for example, an aluminum substrate or an epoxy substrate. Each of light sources **352**, shown in FIGS. **4** and **5**, is configured by aligning multiple light sources **352** of FIG. **6A**. In a second configuration example of light sources **352** shown in FIG. **6B**, LED **357R** of R, LED **357G** of G, LED **357B** of B, and LED **357G** of G are mounted on substrate **356** in a rhombic shape. Each of light sources **352**, shown in FIGS. **4** and **5**, is configured by aligning multiple light sources **352** of FIG. **6B**.

[0092] In a third configuration example of light source **352** shown in FIG. **6C**, twelve LED chips, each portion of which integrally includes LED **357R** of R, LED **357G** of G, and LED **357B** of B, are mounted on substrate **356**. Each of light sources **352**, shown in FIGS. **4** and **5**, is configured by aligning multiple light sources **352** of FIG. **6C**. In a fourth configuration example of light source **352** shown in FIG. **6D**, two LED **357Ws** of white (W) are mounted on substrate **356**. Each of light sources **352**, shown in FIGS. **4** and **5**, is configured by aligning multiple light sources **352** of FIG. **6D**. Further, LED **357Ws** are in two types, one in which a yellow fluorescent substance is excited by a light irradiated from an LED of B to generate white light, and a second in which fluorescent substances of R, G, and B are excited by ultraviolet rays irradiated from an LED to generate white light. Any of the above two types can be employed.

[0093] Returning back to FIG. **1**, a configuration and operation of backlight luminance controller **20** will be described. Besides non-uniformization processor **21**, backlight luminance controller **20** includes light emission luminance calculator **22**, white balance adjustor **23**, and PWM timing generator **24**. For simplicity sake, backlight device **35** will be described as backlight device **35A** shown in FIG. **4**. Taking the maximum luminance of a backlight as B_{max} , the light emission luminance of each of backlight regions **35a** to **35d** of backlight device **35** may be obtained by multiplying G_{max1}/G_{max0} , which is obtained for each of regions **34a** to **34d**, by maximum luminance B_{max} . In this way, non-uniformization processor **21** obtains luminances B_1 to B_4 that the backlights of regions **35a** to **35d** are expected to emit.

[0094] Calculated light emission luminances B_1 to B_4 are not for the light right above light sources **352** when the backlight light sources emit light, but are from lights emitted from backlight device **35** itself. That is, in the configuration

examples of FIGS. 4 and 5, light emission luminances B_1 to B_4 are over optical sheets or the like 355. Incidentally, the calculated light emission luminance from a light that is expected to emit from one region of backlight device 35 is collectively referred to as B . In the following description, it is assumed that luminance distributions of light emitted from regions 35a to 35d of the backlight device are uniform within each region. However, in some case the luminance distribution is not uniform in one region. Such case, luminance at any arbitrary point within one region may be any of light emission luminances B_1 to B_4 .

[0095] When gradations of all the image signals on regions 34a to 34d are the same, all the light emission luminances B_1 to B_4 of regions 35a to 35d have heretofore been the same. That is, calculated light emission luminances B_1 to B_4 are set as real light emission luminances. Meanwhile, in the first embodiment, non-uniformization processor 21 multiplies the calculated light emission luminances B_1 to B_4 by non-uniformization coefficients p_1 to p_4 so that the light emission luminances of lights really emitted from the regions 35a to 35d are set as p_1B_1 , p_2B_2 , p_3B_3 , and p_4B_4 . Each of coefficients p_1 to p_4 is greater than 0, and equal to 1 or less.

[0096] The inventors have found the following relationship between the quality of images displayed on liquid crystal panel 34 and the conditions where the backlights emit. Specifically, the image quality is higher when the backlights emit lights with slightly lower light emission luminances than calculated ones, along a periphery of the screen of liquid crystal panel 34.

[0097] Therefore, in the example of FIGS. 4 in which the region of backlight device 35 is divided along one dimension into four sub-regions, it is preferable to set different light emission luminances for each of the lights emitting from 4 regions. Specifically, light emission luminances B_1 and B_4 from regions 35a and 35d equivalent to upper and lower parts of the screen may be set lower than those B_2 and B_3 from regions 35b and 35c. More specifically, as an example, p_1 is set to 0.8; p_2 and p_3 are set to 1; and p_4 is set to 0.8.

[0098] When the luminances of regions 34b and 34c of liquid crystal panel 34 are 500 [cd/m²] in an all white state in which liquid crystal panel 34 entirely displays a white color, each luminance of regions 34a and 34d is set to 400 [cd/m²]. Accordingly, the power consumption of regions 35a and 35d can be reduced by 20%. Therefore, in the first embodiment, non-uniformization processor 21 allow reduction of power consumption by backlight device 35, while rather enhancing the quality of images displayed on liquid crystal panel 34, and not degrading the quality thereof. When considering both the quality of images and the power consumption, it is preferable that the coefficients p_1 to p_4 be set to 0.8 to 1.0. That is, the coefficient p to be multiplied to each light emission luminance of backlights at a screen center is set to 1.0, and that to each light emission luminance at a periphery of the screen is set to a value in a range having a lower bound of 0.8.

[0099] Further, the non-uniformization coefficient p in the case where liquid crystal panel 34 and backlight device 35 are divided into regions in two dimensions will be described. As exemplified here, liquid crystal panel 34 and backlight device 35 are divided into eight regions horizontally and vertically respectively, i.e., they are divided in two dimensions into sixty-four regions. In this case, as shown in FIG. 7, backlight device 35 has regions 35a1 to 35a8, 35b1 to 35b8, 35c1 to 35c8, 35d1 to 35d8, 35e1 to 35e8, 35f1 to 35f8, 35g1 to 35g8, and 35h1 to 35h8. Although not shown particularly, liquid

crystal panel 34 is partitioned into sixty-four regions that correspond to the sixty-four regions of backlight device 35.

[0100] FIG. 8A illustrates an example wherein coefficient p is multiplied to each of calculated light emission luminances of respective regions 35c1 to 35c8, 35d1 to 35d8, 35e1 to 35e8, 35f1 to 35f8, which correspond to four rows of the backlight device 35 in the central part thereof in the vertical direction and wherein each indicate eight regions in the horizontal direction. In FIG. 8A, the left and right directions show regions of the screen of liquid crystal panel 34 in the horizontal direction. The left-hand side corresponds to the left end of the screen, and the right-hand side corresponds to the right end thereof. In this example, for four regions that are horizontally centered, coefficient p is set to 1; regions on the left and right sides are set to 0.9; and regions on the left and right ends are set to 0.8.

[0101] Preferably coefficient p is set to decrease gradually in sequence from the central part, where the coefficient p is 1, to the left and right ends. At this time, it is preferable that coefficient p be laterally symmetric with respect to the middle in the horizontal direction. Here, coefficient p has been set to 1 for the central four regions. However, coefficient p may be set so that the coefficient p takes the value of 1 for the central two regions. Here, coefficient p decreases in sequence from a value less than 1, to 0.8, for regions from the left and right sides of these two regions towards the left and right ends. In addition, when each of the rows is divided into an odd number in the horizontal direction, a region may have a coefficient p of 1. Characteristics of coefficient p in the horizontal direction may be further adjusted to provide the most favorable image quality on a real screen.

[0102] FIG. 8B is a view showing an example of a coefficient p that is multiplied to calculate each light emission luminance of respective regions 35a3 to 35h3, 35a4 to 35h4, 35a5 to 35h5, and 35a6 to 35h6, which correspond to four columns of the backlight device 35 in the central part thereof in the horizontal direction and which each indicate eight regions in the vertical direction. In FIG. 8B, the left and right directions show the vertical direction of the screen of liquid crystal panel 34. The left-hand side corresponds to an upper end of the screen, and the right-hand side corresponds to a lower end thereof. In this example, for four vertically centered regions, coefficient p is set to 1. In this case, regions on the upper and lower sides thereof are set to 0.9; and regions on the upper and lower ends are set to 0.8.

[0103] Also in the vertical direction, it is preferable that coefficient p be set to decrease gradually in sequence from the central part, where the coefficient p is 1, to the upper and lower ends. At this time, it is preferable that coefficient p be symmetric with respect to the middle in the vertical direction toward the upper and lower ends. Here, coefficient p has been set to 1 for the central four regions. However, coefficient p may be set to take the value of 1 for the central two regions. In this instance, coefficient p decreases in sequence from a value less than 1, to 0.8 for regions from the upper and lower sides of these two regions toward the upper and lower ends. In addition, when each of the columns is divided into an odd number in the vertical direction, one region may have a coefficient p of 1. Characteristics of the coefficient p in the vertical direction may be adjusted to provide a most favorable image quality on a real screen. Incidentally, the characteristics of coefficient p in the horizontal and vertical directions may differ from each other.

[0104] As described above, data are obtained from non-uniformization processor 21 that indicate light emission luminances of lights that are actually expected from respective regions of backlight device 35. Controller 50 supplies coefficient p for use in non-uniformization processor 21. Controller 50 can be configured by a microcomputer, and coefficient p can be arbitrarily varied. Data that indicate each light emission luminance is inputted into light emission luminance calculator 22, and the luminance of light that each light source 352 is expected to emit is calculated as follows. A calculation method of luminance of light that each of light sources 352 is expected to emit will be described, in the case where backlight device 35 represents backlight device 35A having regions 35a to 35d. Light emission luminances of lights to be actually emitted from regions 35a to 35d are represented by p_1B_1 , p_2B_2 , p_3B_3 , and p_4B_4 respectively.

[0105] FIG. 9A shows a sectional view of FIG. 4B in a laid flat position. Here, optical sheets or their like 355 are omitted. Light emissions from regions 35a to 35d are represented by p_1B_1 , p_2B_2 , p_3B_3 , and p_4B_4 respectively, and are denoted: $p_1B_1=B_1'$, $p_2B_2=B_2'$, $p_3B_3=B_3'$, and $p_4B_4=B_4'$. B' with "" represents a light emission luminance value on which a non-uniformization process is performed by non-uniformization processor 21, while B without "" represents a light emission luminance value on which a non-uniformization process is not performed. In addition, B_{o1} , B_{o2} , B_{o3} , and B_{o4} represent luminances directly above light sources 352 of regions 35a to 35d respectively, assuming that each light source 352 emits a light individually. As described previously, backlight device 35 has a structure wherein light that emits from each of light sources 352 of regions 35a to 35d is allowed to leak to other regions, so that the light emission luminances B_1' , B_2' , B_3' , and B_4' and the light emission luminances B_{o1} , B_{o2} , B_{o3} , and B_{o4} are respectively not identical. Incidentally, the small light attenuation due to the presence of diffusion plate 354 and optical sheets or their like 355 can be ignored. In addition, the light emission luminance directly above light sources 352 when light source 352 on one region of backlight device 35 individually emits a light collectively are referred to as B_o .

[0106] As shown in FIG. 9A, when all light sources 352 of respective regions 35a to 35d emit lights, each light from corresponding light sources 352 leaks to nearby regions, while showing up as light leakage L_1 with a the light emission luminance that is k multiplied by a corresponding B_{o1} , B_{o2} , B_{o3} , or B_{o4} . Here, k represents an attenuation coefficient when light leaks. The value of k is greater than 0 and less than 1. Further, the leakage light emission from a corresponding light source 352 and which leaks out of the region thereof to other regions, is examined. FIG. 9B shows a state in which only light source 352 on region 35a emits a light. The light emitted therefrom leaks to other regions 35b to 35d. Light emitted from light source 352 onto region 35a at light emission luminance B_{o1} leaks to region 35b while represented as leakage light L_2 having a luminance of kB_{o1} . The leakage light L_1 having a luminance of kB_{o1} , further, becomes leakage light L_2 having a luminance of k^2B_{o1} , which is k times luminance kB_{o1} , and leaks to region 35c. Leakage light L_2 having a luminance of k^2B_{o1} , further, becomes leakage light L_3 having a luminance of k^3B_{o1} , which is k times luminance k^2B_{o1} , and leaks to region 35d.

[0107] In FIG. 9B, light having a light emission luminance of approximately B_{o1} is emitted from region 35a. A light is emitted from region 35b with the leakage light L_1 having a light emission luminance of kB_{o1} as a light source thereof. A

light is emitted from region 35c with the leakage light L_2 having a light emission luminance of k^2B_{o1} as a light source thereof, and a light is emitted from region 35d with the leakage light L_3 having a light emission luminance of k^3B_{o1} as a light source thereof.

[0108] FIG. 10 is a table showing luminances of lights emitted from regions 35a to 35d the time when each of light sources 352 of regions 35a to 35d is individually turned on. Luminances of lights emitted from respective regions 35a to 35d at the time when all light sources 352 of regions 35a to 35d are turned on are summed luminances in the vertical direction as shown in Table of FIG. 10. That is, the luminance of a light emitted from region 35a is given by $B_{o1}+kB_{o2}+k^2B_{o3}+k^3B_{o4}$, and that emitted from region 35b is given by $kB_{o1}+B_{o2}+kB_{o3}+k^2B_{o4}$. The luminance of a light emitted from region 35c is given by $k^2B_{o1}+kB_{o2}+B_{o3}+kB_{o4}$, and that emitted from region 35d is given by $k^3B_{o1}+k^2B_{o2}+kB_{o3}+B_{o4}$. Since each emission luminance of light emitted from regions 35a to 35d is represented by B_1' to B_4' respectively, it can be seen that B_1' is given by $B_{o1}+kB_{o2}+k^2B_{o3}+k^3B_{o4}$ for region 35a, B_2' by $kB_{o1}+B_{o2}+kB_{o3}+k^2B_{o4}$ for region 35b, B_3' by $k^2B_{o1}+kB_{o2}+B_{o3}+kB_{o4}$ for region 35c, and B_4' by $k^3B_{o1}+k^2B_{o2}+kB_{o3}+B_{o4}$ for region 35d.

[0109] Eq. (1) shown in FIG. 11A represents a matrix equation which more specifically is a conversion equation for obtaining light emission luminances B_1' , B_2' , B_3' , and B_4' from light emission luminances B_{o1} , B_{o2} , B_{o3} , and B_{o4} emitted from light sources 352. Eq. (2) shown in FIG. 11B represents a matrix equation which more specifically is a conversion equation for obtaining the light emission luminances B_{o1} , B_{o2} , B_{o3} , and B_{o4} from the light emission luminances B_1' , B_2' , B_3' , and B_4' . Eq. (3) shown in FIG. 11C is obtained by rearranging Eq. (2) to make it easy to perform a calculation in a circuit of the light emission luminance calculator 22. Eq. (4) shown in FIG. 11D shows constants a , b , and c of Eq. (3). As seen in Eq. (3) of FIG. 11C, each light emission luminance B_{o1} , B_{o2} , B_{o3} , and B_{o4} can be obtained by multiplying each light emission luminance B_1' , B_2' , B_3' , and B_4' by coefficients (conversion coefficients) based on amounts of light, emitted from each light source 352 of regions 35a to 35d, which leak out of these region to other regions.

[0110] Since the leakage light L_1 from one region of backlight device 35 to nearby regions can be measured, the value of the attenuation coefficient k described in FIGS. 9 and 10 can be determined in advance. Thus, based on Eq. (3) of FIG. 11C and Eq. (4) of FIG. 11D, each of the light emission luminances B_{o1} , B_{o2} , B_{o3} , and B_{o4} of lights that each of light sources 352 of regions 35a to 35d is expected to emit can be accurately calculated.

[0111] Incidentally, when the attenuation coefficient k of leakage light into nearby regions is small, a term with k to the power of two or greater becomes negligibly small. In this case, each of the light emission luminances may be approximated by assuming that light emitted from one region leaks to nearby regions only. That is, the calculation may be performed by zeroing out a term that has k to the power of 2 or greater. In addition, according to the structure of backlight device 35, light emitted from one region may be attenuated not in the form of k^2 times, . . . , k^n times (here, $n=3$), but each leakage light to other regions can be measured in advance so that, in this case also, each expected light emission luminance B_{o1} , B_{o2} , B_{o3} , and B_{o4} that corresponds to light source 352

can be accurately calculated. The same applies to the cases of FIGS. 5 and 7, with the different ways of region divisions shown in these figures.

[0112] When backlight device 35 is divided into eight regions in the vertical direction, each light emission luminance of light emitted from each region is represented by B_1' to B_8' respectively, and each light emission luminance of light directly above the corresponding light source 352 is represented by B_1 to B_8 , assuming that each light source 352 emits light individually. The light emission luminances Bo_1 to Bo_8 can be calculated by Eq. (5) as shown in FIG. 12. Further, generalizing the above, i.e., when backlight device 35 is divided into n regions in the vertical direction (n : a positive integer being equal to 2 or greater), light emission luminances B_1' to B_n' are obtained by Eq. (6) shown in FIG. 13A, and light emission luminances Bo_1 to Bo_n can be calculated using Eq. (7) shown in FIG. 13B.

[0113] Next, a calculation method of light luminance from each light sources 352 will be described wherein backlight device 35 corresponds to backlight device 35B shown in FIG. 5. As shown in FIG. 14, each leakage light, leaked from light source 352 onto regions 35a1 to 35a4, 35b1 to 35b4, 35c1 to 35c4, and 35d1 to 35d4 of backlight device 35B to nearby regions in the horizontal direction, is assumed to be larger than the light emitted from each of light sources 352 by m times. An attenuation coefficient m in the horizontal direction is between 0 and 1. The emission of light that leaks to nearby regions in the vertical direction is k times the light emitted from each of light sources 352 as in the case of backlight device 35A. Each light emission luminance for lights that correspond to regions 35a1 to 35a4, 35b1 to 35b4, 35c1 to 35c4, and 35d1 to 35d4 of backlight device 35B that are expected to actually emit is represented by B_{11}' to B_{14}' , B_{21}' to B_{24}' , B_{31}' to B_{34}' , and B_{41}' to B_{44}' respectively. To obtain each light emission luminance B_{11}' to B_{14}' , B_{21}' to B_{24}' , B_{31}' to B_{34}' , and B_{41}' to B_{44}' , each expected light emission luminance of light sources 352 onto their respective regions is represented by Bo_{11} to Bo_{14} , Bo_{21} to Bo_{24} , Bo_{31} to Bo_{34} , and Bo_{41} to Bo_{44} respectively.

[0114] When applying the calculation method described in FIGS. 9 and 10 in which leakage lights are considered, to that in the horizontal direction, a matrix equation shown in FIG. 15 is obtained. Eq. (8) shown in FIG. 15A is a conversion equation given by a matrix equation for obtaining the light emission luminances B_{11}' to B_{44}' from the light emission luminances Bo_{11} to Bo_{44} of lights that light sources 352 emit. Eq. (9) shown in FIG. 15B is a conversion equation given by a matrix equation for obtaining the light emission luminances Bo_{11} to Bo_{44} from the light emission luminances B_{11}' to B_{44}' . By rearranging Eq. (9), Eq. (10) shown in FIG. 15C is obtained. Eq. (11) shown in FIG. 15D shows constants a , b , c , d , e , and f of Eq. (10). Also, as seen in FIG. 14, since the values of attenuation coefficients k and m can be obtained in advance, the light emission luminances Bo_{11} to Bo_{44} of lights that respective light sources 352 of regions 35a1 to 35d4 are expected to emit can be accurately calculated based on Eq. (10) of FIG. 15C and Eq. (11) of FIG. 15D.

[0115] When backlight device 35 is divided into eight regions in both the horizontal and vertical directions, each of light emission luminances that the sixty-four regions are expected to emit is represented by B_{11}' to B_{88}' respectively. Also, each light emission luminance of light directly above the corresponding light sources 352 is represented by Bo_{11} to Bo_{88} , assuming that each light source 352 emits a light indi-

vidually. The light emission luminances B_{11}' to B_{88}' are obtained by Eq. (12) shown in FIG. 16A, and the light emission luminances Bo_{11} to Bo_{88} can be calculated by Eq. (13) shown in FIG. 16B. Further, generalizing the above, backlight device 35 as an example, is divided into n regions in both the horizontal and vertical directions (n : a positive integer being equal to 2 or greater) and light emission luminances Bo_{11} to $Bo_{n,n}$ can be calculated by Eq. (14) shown in FIG. 17 using light emission luminances B_{11}' to $B_{n,n}'$. Although not shown in the drawing, even when backlight device 35 is divided into nh regions (nh : a positive integer being equal to 2 or greater) in the horizontal direction, and further divided into nv regions (nv : a positive integer being equal to 2 or greater, not being the same value as nh) in the vertical direction, a matrix equation will be used as in the above case so that light emission luminances of lights that respective light sources 352 are expected to emit can be accurately calculated.

[0116] Returning to FIG. 1, the attenuation coefficients k and m for light emission luminance calculator 22 are supplied from controller 50. The attenuation coefficients k and m can be varied arbitrarily. Data thus obtained, which indicate light emission luminances of lights that respective light sources 352 on multiple regions of backlight device 35 emit, are supplied to white balance adjuster 23. Temperature data indicative of a temperature of backlight device 35, and color temperature data indicative of a color temperature of a light emitted from backlight device 35 are inputted to white balance adjuster 23. The temperature data described above are outputted from temperature sensor 37, while color temperature data described above are outputted from color sensor 38.

[0117] As described above, the luminance of a light emitted from an LED (an LED for R in particular) changes according to the change of the temperature of backlight device 35. Therefore, when light sources 352 include LEDs of three colors, white balance adjuster 23 adjusts the amount of light of LEDs of R, G, and B based on the temperature data and the color temperature data so that a white balance can be adjusted to optimum. Incidentally, the white balance of backlight device 35 can also be adjusted using an external control signal S_{ctrl} supplied from controller 50. In addition, when a change, caused by temperature change or variation with time, in the white balance of backlights is small, white balance adjuster 23 can be eliminated.

[0118] Data outputted from white balance adjuster 23 are supplied to PWM timing generator 24. The data indicate the luminances of lights from respective sources 352 onto multiple regions of backlight device 35, are supplied to white balance adjuster 23. When each light source 352 is an LED, the light emission of an LED of each color is controlled using, for example, a pulse duration modulation signal. PWM timing generator 24 supplies backlight driver 36 with PWM timing data, which includes timing for the pulse duration modulation signal, and pulse duration for adjusting the amount of light emission (light emission time). Backlight driver 36 generates a drive signal as a pulse duration modulation signal based on the PWM timing data thus inputted, and drives the light sources (LEDs) of backlight device 35.

[0119] The above description is an example wherein each LED is driven by the pulse duration modulation signal. However, it is also possible to control each of the light emission luminances of the LEDs by adjusting the current flowing through the LEDs. In this case, instead of PWM timing generator 24, a timing generator may be provided that generates timing data for determining when current flows through the

LEDs, and the value of the current. In addition, for non-LED light sources, the light emission may be controlled differently, according to the type of light source, and a timing generator generating timing data according to the kind of light sources may be provided. In FIG. 1, although backlight luminance controller 20 and controller 50 are separately provided, all or part of the backlight luminance controller 20 circuits can be provided in controller 50. Further, in the configuration of FIG. 1, for example, the maximum gradation detector 11, image gain calculation unit 12, and backlight luminance controller 20 may be configured in hardware, software, or combinations thereof. Without having to repeat the description, i.e., the description on a synchronization in which the displaying of respective frames of image signals on liquid crystal panel 34, the image signals being outputted from image signal processor 10, and the controlling of backlight luminances by backlight luminance controller 20 according to a maximum luminance of image signals are synchronized with each other. In FIG. 1, the drawing of a configuration on the synchronizing of both described above has been omitted.

[0120] Referring to FIG. 18, further described is the foregoing operation of the liquid crystal display device shown in FIG. 1, and a procedure of performing the foregoing image display in the liquid crystal display device. In FIG. 18, (Step S11), maximum gradation detector 11 detects a maximum gradation of an image signal for each region of liquid crystal panel 34. In Step S12, image gain calculator 12 calculates a gain, which is multiplied to image signals for display on respective regions of liquid crystal panel 34. In Step S13, liquid module unit 30 displays the image signals of the respective regions multiplied by the gain. Steps S14 to S17 are performed in parallel with Steps S12 and S13.

[0121] In Step S14, non-uniformization processor 21 obtains light emission luminances B of lights that are expected from multiple regions of backlight device 35, and multiplies the light emission luminances B by a coefficient p (to be thereafter set as light emission luminances B') so that the luminances of the multiple regions of liquid crystal panel 34 are made non-uniform. In Step S16, light emission luminance calculator 22 obtains light emission luminances Bo of lights to be emitted from light sources 352 themselves on multiple regions of backlight device 35, using a calculation equation using the light emission luminance B' and a conversion coefficient. Further, in Step S17, PWM timing generator 24 and backlight driver 36 causes light sources 352 on multiple regions of backlight device 35 to emit as light emission luminance Bo with synchronization established with Step S13.

[0122] In the configuration shown in FIG. 1, non-uniformization processor 21 obtains light emission luminances B' on which a non-uniformization process is performed, and light emission luminance calculator 22 obtains light emission luminances Bo based on this light emission luminances B'. However, a non-uniformization process may be performed after obtaining the light emission luminance Bo using light emission luminance calculator 22. That is, non-uniformization processor 21 and light emission luminance calculator 22 may be interchanged. Such operation and a procedure for this will be described in refer to FIG. 19.

[0123] In FIG. 19, Steps S21 to S23 are the same as Steps S11 to S13 of FIG. 18. In Step 24, light emission luminance calculator 22 obtains the light emission luminances B of lights that are expected from multiple regions of backlight device 35, and further, in Step S26, obtains light emission

luminances Bo of lights from light sources 352 themselves on multiple regions of backlight device 35, using a calculation equation that employs light emission luminance B and a conversion coefficient. In Step S25, non-uniformization processor 21 multiplies the light emission luminances Bo by the coefficient p, and sets the result as light emission luminance Bo'. Further, in Step S27, PWM timing generator 24 and backlight driver 36 causes light sources 352 on multiple regions of backlight device 35 to emit light at light emission luminance Bo' with synchronization established by Step S23. [0124] Incidentally, a non-uniformization process by non-uniformization processor 21 is necessary when it is desired to further reduce power consumption of backlight device 35 over the configurations described in Non-Patent Document 1 and Patent Documents 1 to 3 described above; however, when the level of required power consumption is the same as that in the configurations of the above-mentioned documents, it is possible to eliminate non-uniformization processor 21. Operation and a representative procedure in this case will be described referring to FIG. 20. In FIG. 20, Steps S31 to S33 are the same as Steps S11 to S13 of FIG. 18. In Step 34, light emission luminance calculator 22 obtains light emission luminances B of lights which are expected to emit from multiple regions of backlight device 35, and further, in Step S36, obtains light emission luminances Bo of lights to emit from light sources 352 themselves on multiple regions of the backlight device 35, with a calculation equation using the light emission luminance B and a conversion coefficient. Further, in Step S37, PWM timing generator 24 and backlight driver 36 causes light sources 352 on multiple regions of backlight device 35 to emit light at light emission luminance Bo with synchronization established via Step S33.

[0125] As described above, in the liquid crystal display device of the first embodiment, backlight device 35 has a structure wherein light emitted from respective light sources 352 of multiple regions are allowed to leak to other regions, so that it is not necessary to establish an accurate correspondence between the regions of liquid crystal panel 34 and the regions of backlight device 35. Further, it is possible to accurately obtain the light emission luminances B of lights emitted from the multiple regions of backlight device 35, using the light emission luminances Bo of light sources 352 themselves in the case where light sources 352 of the respective regions individually emit. Therefore, it is possible to accurately control the luminances of backlights that irradiate multiple regions on liquid crystal panel 34 according to the brightness of image signals to be displayed on these regions.

[0126] Further, the respective regions of liquid crystal panel 34 are not completely independent, and light emission luminances Bo are obtained by considering the structure in which light emitted from each of light sources 352 leaks to other regions through use of a calculation equation. Therefore, it is possible to enhance the quality of images displayed on liquid crystal panel 34 so that non-uniformities in brightness and color do not tend to occur on multiple regions of liquid crystal panel 34.

Second Embodiment

[0127] FIG. 21 is a block diagram showing the entire configuration of a liquid crystal display device of a second embodiment. In FIG. 21, the parts that are the same as those shown in FIG. 1 are given the same reference numerals, so that further description thereof is omitted. Further, for the sake of simplicity in, the configuration of FIG. 21, the non-

uniformization processor **21** of FIG. **1** has been eliminated, but this may include non-uniformization processor **21** in FIG. **1** as in the first embodiment.

[0128] As described above, in the first embodiment, light emission luminance calculator **22** calculates light emission luminances B_0 of lights from light sources **352** themselves of multiple regions of backlight device **35**, and causes each light source **352** of multiple regions to emit light. The light emission luminances B_0 each indicate a luminance value at the center of each one of the regions. FIG. **22A** shows luminance distribution in the case where only region **35b** emits light. Here, region **35b** is one of four regions of backlight device **35A** into which backlight device **35** is divided in the vertical direction as in FIG. **4A**. When region **35b** emits light at light emission luminance B_{02} shown in FIG. **22A**, the light emission luminances of regions **35a** and **35c** each become kB_{02} , and that of region **35d** becomes k^2B_{02} . This forms a luminance distribution such as shown in the drawing. In this case, the amount of light emitting from light source **352** of region **35b** can be indicated by the region with hatch lines seen in FIG. **22B**. That is, the amount of light shown in FIG. **22B** is represented by an integral value of light in a range of the luminance distribution of FIG. **22A**.

[0129] Preferably light emission luminances B of lights emitted from multiple regions are obtained using an integral value of light emitted from light source **352**, rather than based on light emission luminance B_0 of light that emits from light source **352** itself of each region. For this reason, in the second embodiment shown in FIG. **21**, between light emission luminance calculator **22** and white balance adjustor **23**, an amount-of-emitted light calculator **25** is provided, which converts light emission luminance B_0 into an amount of emitted light B_{0ig} as an integral value. The amount of emitted light B_{0ig} can be easily obtained from a calculation equation, which converts light emission luminance B_0 into amount of emitted light B_{0ig} .

[0130] FIG. **23A** is a calculation equation in the embodiment wherein backlight device **35** is backlight device **35A**. FIG. **23B** shows constants s_1 to s_4 in Eq. (15) shown in FIG. **23A**, and expresses these constants s_1 to s_4 by Eq. (16), using an attenuation constant k . Further, the equations shown in FIGS. **23A** and **23B** are approximate and convert a light emission luminance B_0 into amount of emitted light B_{0ig} . For example, when region **35a** of backlight device **35A** emits light, an integral value of a light irradiating liquid crystal panel **34** can be approximately expressed by Eq. (17) of FIG. **24**, and the term k^3 is sufficiently small, hence being negligible, so that the integral value can be expressed by Eq. (18). Further, when region **35b** of backlight device **35A** emits light, an integral value of light irradiating liquid crystal panel **34** can be approximately expressed by Eq. (19), and rearranging of Eq. (19) gives Eq. (20). When partitioning backlight device **35** into multiple regions in the vertical direction, a coefficient s by which light emission luminances B_0 of regions located on upper and lower ends are multiplied is equal to $1+k$, and a coefficient s by which light emission luminances B_0 of respective regions sandwiched by those on upper and lower ends are multiplied is equal to $(1+k)/(1-k)$.

[0131] FIG. **25A** indicates a calculation equation for obtaining an amount of emitted light B_{0ig} based on light emission luminance B_0 , in the example of backlight device **35B** shown in FIGS. **4** and **14**. Constants s_1 to s_4 in Eq. (21) shown in FIG. **25A** are given by Eq. (16) shown in FIG. **23B**, and constants t_1 to t_4 can be expressed by Eq. (22) of FIG.

25B, by using an attenuation coefficient m . When partitioning backlight device **35** in both horizontal and vertical directions, coefficient s by which light emission luminances B_0 of regions located on upper and lower ends are multiplied, is represented as equal to $1+k$, and coefficient s by which light emission luminances B_0 of respective regions sandwiched by those on upper and lower ends are multiplied, is equal to $(1+k)/(1-k)$. Coefficient t , by which light emission luminances B_0 of regions located on left and right ends are multiplied, is equal to $1+m$, and coefficient t , by which light emission luminances B_0 of respective regions sandwiched by those on the left and right ends are multiplied is equal to $(1+m)/(1-m)$.

[0132] In FIG. **21**, data indicative of the amount of light B_{0ig} output from amount-of-emitted light calculator **25** are supplied to PWM timing generator **24** through white balance adjustor **23**. PWM timing generator **24** generates PWM timing data for adjusting the duration of a pulse duration modulation signal for generation by backlight driver **36**, based on data indicative of the amount of emitted light B_{0ig} . Thus, in the second embodiment, backlight driver **36** drives light sources **352** of respective regions according to emitted light B_{0ig} from light sources **352** of the respective regions of backlight device **35**, so that it becomes possible to control light emission luminances B of light from multiple regions more adequately than the first embodiment.

[0133] The calculation equations converting the light emission luminances B_0 into amounts of emitted light B_{0ig} as described using FIGS. **23** to **25** are those for approximately obtaining the amount of emitted light B_{0ig} as described above, and not for completely representing an integral value of a light corresponding to a region with hatching shown in FIG. **22B**. However, even when they are only approximate, it is possible to obtain a value for emitted light B_{0ig} that corresponds to the integral value of light. The integral value of a light may be more accurately obtained using a further complicated calculation equation.

Third Embodiment

[0134] FIG. **26** is a block diagram showing an entire configuration of a liquid crystal display device of a third embodiment. In FIG. **26**, the parts which are the same as those shown in FIG. **1**, are given the same reference numerals, so that a further description thereof is omitted. Further, for the sake of simplicity, the non-uniformization processor **21** in FIG. **1** has been eliminated from FIG. **26**, but may include as in the case of the first embodiment. Further, the amount-of-emitted light calculator unit **25** has been included in FIG. **26** as in the second embodiment, but also may be eliminated.

[0135] FIG. **27A** is a view showing the case where liquid crystal panel **34A** is divided into regions **34a** to **34d** so that regions **34a** to **34d** correspond to regions **35a** to **35d** of backlight device **35A** respectively. This figure also shows the case where the gradations of regions **34a**, **34b**, and **34d** are zero (i.e., black), and the gradation of region **34c** is at maximum gradation 255 (i.e., white). In this case, light emission luminances B of light from regions **35a** to **35d** of backlight device **35A** become B_1 , B_2 , B_3 , and B_4 respectively as shown in FIG. **27B**. In this case, light emission luminances B_0 of light from light sources **352** themselves on regions **35a** to **35d** of backlight device **35** become B_{01} , B_{02} , B_{03} , and B_{04} respectively in the calculation thereof as shown in FIG. **27C**, and those on regions **35a**, **35b**, and **35d** take negative values.

[0136] Here, suppose that: backlight device 35 is divided into n regions in the vertical direction; B_{o1} denotes light emission luminances of lights to be emitted from light sources 352 themselves of regions on an upper end; B_{on} denotes light emission luminances of lights to be emitted from light sources 352 themselves of regions on a lower end; and B_{oi} denotes light emission luminances of lights to be emitted from light sources 352 themselves of regions sandwiched by the upper and lower ends. In this case, B_{o1} , B_{on} , and B_{oi} take negative values due to calculation when light emission luminances B_1 , B_n , and B_n of lights emitted from respective regions fall in the condition indicated by Eq. (23) of FIG. 28A. As shown in Eq. (23), the condition in which the light emission luminances B_o take negative values depends on the attenuation coefficient k .

[0137] Therefore, in the third embodiment, when light emission luminances B_1 to B_n fall in the condition given in Eq. (23), the light emission luminances B_1 to B_n are corrected so as to satisfy the condition given in Eq. (24) of FIG. 28B, and thereafter the light emission luminances B_o are obtained. In order to avoid conditions where B_o does not take negative values, Eq. (25) of FIG. 28C must be satisfied. Luminance values of B are allowed to take higher values using Eq. (24) over Eq. (25) not only in order to correct the light emission luminances B so as not to cause the light emission luminances B_o become negative, but also to allow the light emission luminances B to increase on purpose in a range in which viewing is adversely affected.

[0138] FIGS. 29A to 29F show conditions and corrections of light emission luminances B , in which light emission luminances B_o take negative values when the case where backlight device 35 is divided into multiple regions in both the horizontal and vertical directions. A subscript, i , of a light emission luminance B denotes an arbitrary i -th region in the vertical direction, and a subscript, j , denotes an arbitrary j -th region in the horizontal direction. Eq. (26) of FIG. 29A shows a condition for light emission luminances B in which light emission luminances B_o become negative by calculation on respective regions arranged in the vertical direction. When the light emission luminances B fall in a condition shown in Eq. (26), the light emission luminances B are first corrected so as to satisfy Eqs. (27) and (28) of FIGS. 29B and 29C, and thereafter the light emission luminances B_o are obtained.

[0139] Eq. (29) of FIG. 29D shows a condition for the light emission luminances B in which the light emission luminances B_o become negative in calculation on respective regions arranged in the horizontal direction. As shown in Eq. (29), the condition in which the light emission luminances B_o become negative in calculation in the case of the horizontal direction is determined depending on the attenuation coefficient m . When the light emission luminances B fall within the condition shown in Eq. (29), light emission luminances B are first corrected so as to satisfy Eqs. (30) and (31) of FIGS. 29E and 29F, and thereafter the light emission luminances B_o are obtained.

[0140] FIG. 27D shows light emission luminances B , the luminance values of which are corrected so that the light emission luminances B_o of negative values as shown in FIG. 27C do not occur. When obtaining light emission luminances B using the light emission luminances B shown in FIG. 27D, light emission luminances B_o do not become negative as shown in FIG. 27E.

[0141] Returning to FIG. 26, a configuration and operation of the third embodiment will be described. In the configura-

tion of FIG. 1, image gain calculator 12 obtains a gain using data inputted from maximum gradation detector 11, the data indicating maximum gradations of respective regions of liquid crystal panel 34. However, the third embodiment shown in FIG. 26 is configured as follows. As shown in FIGS. 28 and 29, when the light emission luminances B_o become negative by calculation, light emission luminance calculator 22 corrects the light emission luminances B so that the luminance values of the light emission luminances B_o can be 0 or greater. Thereafter, light emission luminance calculator 22 obtains light emission luminances B_o based on the corrected light emission luminances B , and supplies the same to amount-of-emitted light calculator 25. The light emission luminances B thus corrected are supplied to image gain calculator 12. The image gain calculator 12 calculates a gain by which an image signal is multiplied, based on the corrected light emission luminances B .

[0142] Even in the case where image gain calculator 12 obtains a gain using data indicative of maximum gradations of image signals of respective regions, or even in the case where a gain is obtained using the corrected light emission luminances B , image gain calculator 12 is assumed to obtain a value as a gain for an image signal for each region. The value corresponds to that obtained by dividing a maximum gradation that the image signal may take, and wherein the maximum gradation is determined from a bit count of an image signal, by a maximum gradation of an image signal on each region.

[0143] In this third embodiment, it is not necessary to supply data indicative of maximum gradations of respective regions from maximum gradation detector 11 to image gain calculator 12. As shown by a dashed arrow of FIG. 26 from maximum gradation detector 11 to image gain calculator 12, data indicative of maximum gradations of respective regions may be supplied from maximum gradation detector 11 to the image gain calculator 12 as in the first embodiment. It is also possible to obtain gains using the corrected light emission luminances B instead of the data indicative of maximum gradations, only when the light emission luminances B_o become negative in calculation.

Fourth Embodiment

[0144] The fourth embodiment maybe configure as described for any one of the above first to third embodiments. In the fourth embodiment, studies have been made on how luminance distribution characteristics should be treated is preferable, the luminance distribution characteristics being those of lights emitted from light sources 352 of backlight device 35, and this embodiment is configured, to which light sources 352 having preferable luminance distribution characteristics are adopted.

[0145] FIG. 30A is a view showing luminance distribution characteristics of a light emitted from one light source 352 on one region of backlight device 35. For the sake of simplicity, the light source is assumed to be a point light source. The luminance distribution characteristics shown in FIG. 30A correspond to those in the case where a section is viewed, along which respective regions of backlight devices 35A and 35B are each in the vertical direction. In FIG. 30A, a vertical axis indicates luminance value, and a horizontal axis indicates distance from light source 352. Further, here, in the drawing, luminance values are indicated in which these are normalized with respect to a maximum luminance value being equal to 1 (central luminance). W represents the width

of one region in the vertical direction. A curve depicted by the luminance distribution characteristics represents a luminance distribution function $f(x)$.

[0146] The inventors have conducted various experiments, and found that, for example, when causing one region of backlight device 35 to emit a light, a boundary of the region is viewed as a boundary step depending on the condition of the luminance distribution function $f(x)$, thus deteriorating the quality of images displayed on liquid crystal panel 34. FIG. 30B shows a derived function $f'(x)$ of the luminance distribution function $f(x)$. From an experimental result, it has been confirmed that a maximum value (a maximum derivative of the luminance distribution function $f(x)$) of the derived function $f'(x)$ influences visibility of the boundary step.

[0147] As shown in the following table 1, the inventors have selectively used, in backlight device 35, a plurality of light sources having fc1 to fc2 being a luminance distribution functions $f(x)$, luminance distribution characteristics of which are different from each other, and studied the visibility of the boundary step.

TABLE 1

	fc1	fc2	fc3	fc4	fc5	fc6	fc7	fc8
Maximum derivative	1.2	1.4	1.6	1.8	2.0	2.2	2.5	3.0
Presence of boundary step	No	No	No	No	No	Yes	Yes	Yes

[0148] Of the luminance distribution functions fc1 to fc8 in Table 1, FIG. 31A shows fc1, fc3, fc5, fc7, and fc8; FIG. 31B shows derived functions fc1, fc3, fc5, fc7, and fc8 of the luminance distribution functions fc1, fc3, fc5, fc7, and fc8. As shown in Table 1, in order not to make the boundary of the region as a boundary step, it is necessary to use light source 352 having luminance distribution characteristics indicative of a luminance distribution function $f(x)$, an absolute value $|f'(x)|$ of a derived function $f'(x)$ of which takes a maximum value $|f'(x)_{\max}|$ being equal to 2.0 or less. It is naturally necessary that a lower limit of the maximum value $|f'(x)_{\max}|$ does not exceed 0. That is, it is necessary for the maximum value $|f'(x)_{\max}|$ of the absolute value $|f'(x)|$ of the derived function $f'(x)$ to satisfy the condition: $0 < |f'(x)_{\max}| \leq 2.0$.

[0149] Here, the characteristics in the case where the region is cut in the vertical direction are shown. Light from light source 352 spreads concentrically with respect to light source 352 as a center with its luminance attenuated with distance from light source 352, so that the same is true also for the case where luminance distribution characteristics of a light from light source 352 are viewed from the horizontal direction or any direction other than the vertical direction.

[0150] As described above, in the fourth embodiment, as light source 352 of backlight device 35, one having the following condition is used: the maximum value of the absolute value of the derivative indicating a change in a slope of the luminance distribution function $f(x)$ being represented by the curve of the luminance distribution characteristics is equal to 2.0 or less. Therefore, even when causing only part of a plurality of regions of backlight device 35 to emit light, a boundary of the region is not viewed as a boundary step so that the quality of images to be displayed on liquid crystal panel 34 is not deteriorated.

[0151] Further, preferable luminance distribution characteristics are which an effect of reduction of power consumption of backlight device 35 has been taken into account will be described. FIG. 32 is a view showing the same luminance distribution function $f(x)$ as that of FIG. 30A. As shown in FIG. 32, when normalizing a central luminance of light source 352 to 1, a light from light source 352 leaks to a nearby region with the attenuation coefficient k , so that the central luminance of the nearby region becomes k . FIG. 33 is a view showing a relationship between an attenuation coefficient k and a power consumption relative value. In FIG. 33, with a horizontal axis indicative of the attenuation coefficient k and with a vertical axis indicative of the power consumption relative value, power consumption at the time when causing backlight device 35 to emit light at a maximum light emission luminance irrespective of gradation of image signals it set to 100%. Incidentally, in FIG. 33, Img1 and Img2 represent characteristics showing a relationship between attenuation values k and power consumption relative values for still images, pictures of which are different from each other.

[0152] As shown in FIG. 33, power consumption can be reduced by performing a luminance control of backlight device 35 as described in the first embodiment. As can be seen from FIG. 33, power consumption does not change much even when the attenuation coefficient k is increased, in the range of attenuation coefficient k being 0.3 or less. However, power consumption comparatively increases with increasing attenuation coefficient k , in the range of attenuation coefficient k exceeding 0.3. Therefore, it can be said that it is preferable that the attenuation coefficient k be 0.3 or less when considering the effect of reduction of power consumption of backlight device 35. The case for the attenuation coefficient k in the vertical direction has been described, but the same is true of the case for the attenuation coefficient m in the horizontal direction. That is, when lights emitted from respective light sources of a plurality of regions leak to regions nearby in the vertical or horizontal direction to own regions, it is preferable that, when a central luminance of the own region is equal to 1, a central luminance of a region nearby to the own region be greater than 0 and equal to 0.3 or less.

[0153] It is to be understood that the present invention is not limited to the above-described first to fourth embodiments, and various changes may be made therein without departing from the spirit of the present invention. Although liquid crystal panel 34 and backlight device 35 of the first to fourth embodiments are assumed to have a plurality of regions of the same area, different areas may be set to the regions when needed. Further, when an image display device which needs a backlight device is newly developed other than liquid crystal display devices, it is possible to naturally apply the present invention to the new image display device.

Fifth Embodiment

[0154] FIG. 34 is a block diagram showing an entire configuration of the liquid crystal display device of the fifth embodiment. In FIG. 34, the parts, which are the same as those shown in FIGS. 1, 21 and 26 are given the same reference numerals, so that a further description thereof is omitted. Further, for the sake of simplicity, non-uniformization processor 21 in FIG. 1 has been eliminated from FIG. 34, but may be included as in the first embodiment. Further, light emission amount calculator 25 has been included in FIG. 34 as in the second and third embodiments, but also may be eliminated.

[0155] In view of luminance distribution characteristics of light emitted to liquid crystal panel 34, the fifth embodiment employs the following configuration. Specifically, image gain calculator 12 calculates each gain, by which an image signal to be displayed on each of the regions is multiplied, according to a location in the region (such as for each pixel). Accordingly, in the fifth embodiment, image signal processor 100 including luminance bitmap memory 15 is provided instead of image signal processor 10.

[0156] In FIG. 34, an image signal inputted to maximum gradation detector 11 is expressed as $D_{in}(x,y)$. Assume that a pixel at the upper left end of multiple pixels arranged on liquid crystal panel 34 is an origin point (0, 0), and x in (x,y) indicates a pixel location on liquid crystal panel 34 in the horizontal direction, whereas y indicates a pixel location on liquid crystal panel 34 in the vertical direction. An image signal $D_{in}(x,y)$ is data on which gamma correction is performed, so that an image is correctly displayed on a CRT of gamma 2.2. Hence, the brightness, represented on the liquid crystal panel, of input gradation of image signals $D_{in}(x,y)$ forms a 0.45 gamma curve.

[0157] Assume that data is obtained by converting an image signal $D_{in}(x,y)$ so that the relationship between input gradation and brightness becomes linear as $d_{out}(x,y)$. Here, $G^1[\]$ is an equation indicating degamma correction, and a light emission luminance of backlight device 35 at an arbitrary point $P(x,y)$ on liquid crystal panel 34 is expressed as $B(x,y)$. $d_{out}(x,y)$ is expressed by Eq. (32) shown in FIG. 35A. The calculation equation $G^{-1}[\]$ indicating degamma correction multiplies inputted data by approximately 2.2. When an image signal outputted from multiplier 14 in FIG. 34 is $D_{out}(x,y)$, the image signal $D_{out}(x,y)$ is expressed by Eq. (33) shown in FIG. 35B. $G[\]$ is an equation indicating gamma correction, which multiplies inputted data by approximately 0.45. A multiplier to be used in degamma correction and gamma correction may vary depending on the characteristic of liquid crystal panel 34. Substituting Eq. (32) into Eq. (33), the image signal $D_{out}(x,y)$ is expressed by Eq. (34) shown in FIG. 35C.

[0158] Accordingly, image gain calculator 12 in FIG. 34 performs degamma correction on $B(x,y)$ in Eq. (34), to calculate the inverse. Additionally, multiplier 14 multiplies the inverse obtained by performing degamma correction on $B(x,y)$ by the input image signal $D_{in}(x,y)$. As seen in Eq. (34), in the fifth embodiment, an image signal $D_{out}(x,y)$ at an arbitrary point $P(x,y)$ to be supplied to liquid module unit 30 can be obtained without converting an input image signal $D_{in}(x,y)$ into linear data. Incidentally, although the aforementioned first to fourth embodiments do not include descriptions with such equations, conversion to linear data is not performed in these embodiments, either.

[0159] As described with reference to FIG. 30, luminance distribution characteristics of light emitted from backlight device 35 are not uniform in one region of liquid crystal panel 34. Thus, the fifth embodiment is configured to include luminance bitmap memory 15 so that a gain, by which an image signal to be displayed on each of the regions is multiplied, is calculated for each pixel. This configuration is employed in consideration of the luminance distribution characteristics of light emitted from backlight device 35. As shown in FIG. 34, luminance bitmap memory 15 includes a luminance bitmap expressed by luminance distribution characteristics $f_{mn}(x,y)$ of light in respective regions of liquid crystal panel 34. Luminance bitmap memory 15 supplies the luminance distribution

characteristics $f_{mn}(x,y)$ to image gain calculator 12. The subscript m of the luminance distribution characteristics f denotes numbers (1, 2, . . . , m) sequentially assigned in the vertical direction of a region, whereas the subscript n denotes numbers (1, 2, . . . , n) sequentially assigned in the horizontal direction of a region. For instance, suppose that each of liquid crystal panel 34 and backlight device 35 is divided into four regions in the horizontal and vertical directions respectively, i.e., where they are divided into sixteen regions. In this case, luminance bitmap memory 15 holds luminance distribution characteristics $f_{11}(x,y)$ to $f_{44}(x,y)$.

[0160] Although it is preferable that luminance bitmap memory 15 holds luminance distribution characteristics that are set for respective regions, luminance bitmap memory 15 may otherwise hold luminance distribution characteristics $f_{mn}(x,y)$ of any one of the multiple regions, as representative luminance distribution characteristics. Otherwise, luminance bitmap memory 15 may hold average luminance distribution characteristics of the multiple regions. In this embodiment, arbitrary luminance distribution characteristics $f_{mn}(x,y)$ are collectively referred to as $f(x,y)$. Note that the quantization bit of the luminance bitmap held by luminance bitmap memory 15 is preferably 8 bits or more.

[0161] FIG. 36 illustrates an example of luminance distribution characteristics $f_{mn}(x,y)$ of light in a region and its nearby regions on liquid crystal panel 34. In FIG. 36, x denotes coordinates of pixels in the horizontal direction, while y denotes the coordinates of pixels in the vertical direction. Here, widths of a region in the horizontal and vertical directions are each set to 1, and range between -0.5 to $+0.5$ in both directions to form a region. Accordingly, a point where (x,y) takes (0,0) is the center of a region. A light emission luminance B_0 at the center (0,0) is normalized to 1. A ratio between the luminance distribution characteristics $f(0,0)$ of the center (0,0) and the luminance distribution characteristics $f(-1,0)$ of a point where (x,y) takes $(-1,0)$, or the luminance distribution characteristics $f(1,0)$ of a point where (x,y) takes (1,0) indicates an attenuation coefficient m in the horizontal direction. A ratio between the luminance distribution characteristics $f(0,0)$ and the luminance distribution characteristics $f(0,-1)$ of a point where (x,y) takes $(0,-1)$, or the luminance distribution characteristics $f(0,1)$ of a point where (x,y) takes (0,1) indicates an attenuation coefficient k in the vertical direction. Luminance values (i.e. values of $f(x,y)$) of the luminance bitmap shown in FIG. 36 form linear data.

[0162] In the fifth embodiment shown in FIG. 34, light emission luminance B_0 is inputted by light emission luminance calculator 22 to image gain calculator 12. Image gain calculator 12 calculates a light emission luminance $B(x,y)$ for each pixel by use of Eq. (35) shown in FIG. 37. Then, according to the light emission luminance $B(x,y)$, image gain calculator 12 calculates a gain by which an image signal is multiplied for each pixel.

[0163] A description will be given for calculation of Eq. (35) shown in FIG. 37 by use of FIG. 38. In FIG. 38, backlight device 35 includes regions 35₁₁, 35₁₂, . . . , 35₂₁, 35₂₂, . . . , 35₃₁, 35₃₂, . . . , and 35₄₁, 35₄₂, Center coordinates of the regions are (x_{11}, y_{11}) , (x_{12}, y_{12}) , . . . , (x_{21}, y_{21}) , (x_{22}, y_{22}) , . . . , (x_{31}, y_{31}) , (x_{32}, y_{32}) , . . . , and (x_{41}, y_{41}) , (x_{42}, y_{42}) , As indicated with broken lines, a light emission luminance $B(x,y)$ at an arbitrary point $P(x,y)$ in region 35₂₂, for example, is influenced by the light emission luminance B_0 of light emitted from each of the regions. As described above, a pixel at the upper left end of multiple pixels arranged on liquid crystal

panel **34** is assumed to be an origin point (0,0), and the center of luminance distribution characteristics $f(x,y)$ in the respective regions is the origin (0,0). Accordingly, the brightness of light emitted from the respective regions that contribute to position $P(x,y)$ in region **35**₂₂ is expressed as follows by use of light emission luminance B_0 and luminance distribution characteristics $f(x,y)$.

[0164] Contributing brightness of light emitted from region **35**₁₁ is expressed as $B_{011} \times f_{11}(x-x_{11}, y-y_{11})$, contributing brightness of light emitted from region **35**₁₂ is expressed as $B_{012} \times f_{12}(x-x_{12}, y-y_{12})$, contributing brightness of light emitted from region **35**₁₃ is expressed as $B_{013} \times f_{13}(x-x_{13}, y-y_{13})$, and contributing brightness of light emitted from region **35**₁₄ is expressed as $B_{014} \times f_{14}(x-x_{14}, y-y_{14})$. Contributing brightness of light emitted from region **35**₂₁ is expressed as $B_{021} \times f_{21}(x-x_{21}, y-y_{21})$, contributing brightness of light emitted from region **35**₂₂ is expressed as $B_{022} \times f_{22}(x-x_{22}, y-y_{22})$, contributing brightness of light emitted from region **35**₂₃ is expressed as $B_{023} \times f_{23}(x-x_{23}, y-y_{23})$, and contributing brightness of light emitted from region **35**₂₄ is expressed as $B_{024} \times f_{24}(x-x_{24}, y-y_{24})$.

[0165] Contributing brightness of light emitted from region **35**₃₁ is expressed as $B_{031} \times f_{31}(x-x_{31}, y-y_{31})$, contributing brightness of light emitted from region **35**₃₂ is expressed as $B_{032} \times f_{32}(x-x_{32}, y-y_{32})$, contributing brightness of light emitted from region **35**₃₃ is expressed as $B_{033} \times f_{33}(x-x_{33}, y-y_{33})$, and contributing brightness of light emitted from region **35**₃₄ is expressed as $B_{034} \times f_{34}(x-x_{34}, y-y_{34})$. Contributing brightness of light emitted from region **35**₄₁ is expressed as $B_{041} \times f_{41}(x-x_{41}, y-y_{41})$, contributing brightness of light emitted from region **35**₄₂ is expressed as $B_{042} \times f_{42}(x-x_{42}, y-y_{42})$, contributing brightness of light emitted from region **35**₄₃ is expressed as $B_{043} \times f_{43}(x-x_{43}, y-y_{43})$, and contributing brightness of light emitted from region **35**₄₄ is expressed as $B_{044} \times f_{44}(x-x_{44}, y-y_{44})$.

[0166] The light emission brightness $B(x,y)$ at point $P(x,y)$ is obtained by adding up the light emission brightness of its own region and that of surrounding regions, and thus can be obtained by adding up the above contributing brightness of the respective regions. Accordingly, the light emission brightness $B(x,y)$ at point $P(x,y)$ is expressed by Eq. (35) shown in FIG. 37. Eq. (35) is equivalent to an integral form of Eq. (8) in FIG. 15A, expressed so as to correspond to a light source having arbitrary luminance distribution characteristics $f(x,y)$. The number of multiple regions of which light emission brightness are added up is not limited to that in FIG. 38. For example, light emission luminances of a total of 9 regions consisting of each region and the surrounding 8 regions may be added up, or light emission luminances of 25 regions further including the 9 surrounding regions may be added. It is preferable that light emission luminances of 9 or more regions are added.

[0167] The luminance bitmap indicating luminance distribution characteristics $f(x,y)$ shown in FIG. 36 should preferably include data to the extent where the brightness of leakage light becomes so weak that it may be ignored. However, in order to reduce the circuit size, it is preferable that the luminance bitmap includes data limited so as not to affect the image quality. The luminance bitmap preferably includes data within a range where the ratio of leakage light is at least 5% or more of the central luminance. The range where the ratio is less than 5% may be approximated to 0.

[0168] Thus, image gain calculator **12** outputs a gain $\{G[B(x,y)]\}^{-1}$ by which each pixel datum is multiplied. A gain

$\{G[B(x,y)]\}^{-1}$ is an inverse of a value obtained by performing gamma correction on the total of values, each obtained by multiplying a light emission luminance B_0 of light emitted from each light source of multiple regions, calculated by light emission luminance calculator **22**, and data corresponding to an arbitrary point $P(x,y)$ in the luminance bitmap. Thereafter, multiplier **14** outputs an image signal $D_{out}(x,y)$ expressed by Eq. (34) of FIG. 35C.

[0169] The fifth embodiment employs a configuration in which light emission brightness $B(x,y)$ is calculated for each pixel of an image signal, and a gain by which to multiply the image signal is calculated for each pixel on the basis of the light emission brightness $B(x,y)$ of each pixel. However, data of a luminance bitmap may be made rougher than in pixels units, and the image gain calculator **12** may calculate a gain by which to multiply an image signal for units of multiple pixels. In other words, image gain calculator **12** may obtain, in accordance with the luminance bitmap, a different gain value corresponding to a different position in a region consisting of multiple regions, instead of obtaining a gain for each region on liquid crystal panel **34**. However, note that it is preferable to calculate a gain for each pixel for the sake of enhancing image quality.

[0170] It is to be understood that the present invention is not limited to the above-described first to fifth embodiments, and various changes may be made therein without departing from the spirit of the present invention. Although liquid crystal panel **34** and backlight device **35** of the first to fifth embodiments are assumed to have a plurality of regions of the same area, different areas may be set to the regions when needed. Further, when an image display device that needs a backlight device is newly developed other than liquid crystal display devices, it is possible to naturally apply the present invention to the new image display device.

[0171] According to the embodiments of liquid crystal display device and image display method explained above, high quality images on liquid crystal panel can be obtained alleviating variations of the brightness and color among regions, in which backlight is divided, when emission luminance of the backlight is controlled in each region based on image signal.

Sixth Embodiment

[0172] The sixth embodiment may be generally configured as described in any one of the above first to third and fifth embodiments. The sixth embodiment has the configuration in which reflection at an end of backlight device **35** is taken into account in addition to the luminance distribution characteristic of the light emitted from light sources **352** of backlight device **35**.

[0173] FIG. 39 is a view showing an example of divisions of regions in liquid crystal panel **34** and backlight device **35**, while showing a schematic perspective view of a relationship between the regions of liquid crystal panel **34** and the regions of backlight device **35**. Similar to FIG. 2, liquid crystal panel **34** and backlight device **35** are spaced apart from each other. As shown in FIG. 39, backlight device **35** is divided into regions **35a'** to **35h'**, and each of regions **35a'** to **35h'** has light source **352**. Liquid crystal panel **34** is divided into regions **34a'** to **34h'** corresponding to regions **35a'** to **35h'** of backlight device **35**.

[0174] FIGS. 40A and 40B are specific configuration examples of FIG. 39. Hereinafter, a third configuration example of backlight device **35** shown in FIGS. 40A and 40B is referred to as backlight device **35C**. FIG. 40A is a top view

of backlight device 35C. FIG. 40B is a sectional view showing a state in which backlight device 35C is vertically cut. FIG. 40A and 40B have the same configuration as that of FIG. 4, except that backlight device 35 is divided into eight regions 35a' to 35h' in the vertical direction. So in the sixth embodiment, a configuration in which backlight device 35 is divided into eight regions 35a' to 35h' is described. However, the invention is not limited to that configuration.

[0175] FIG. 41 is a view showing light emission luminances B_{01} to B_{08} of light right above light sources 352 in a horizontal direction without consideration of reflection at an end of backlight device 35, assuming that light sources 352 individually emit light in respective regions 35a' to 35h' into which backlight device 35 is divided in the vertical direction. In FIG. 41, relative light emission luminances are used for convenience. In order to facilitate understanding, description will be provided on the assumption that light emission luminances B_{01} to B_{08} are substantially equal to each other. However, light emission luminances B_{01} to B_{08} are not necessarily substantially equal.

[0176] FIG. 42 is a view showing light emission luminances B_1' to B_8' of light emitted from regions 35a' to 35h' into which backlight device 35 is divided in the vertical direction. Broken lines shown in FIG. 42 are light emission luminances B_{01} to B_{08} shown in FIG. 41. Light emission luminances B_1' to B_8' shown in FIG. 42 are each obtained by adding the light emission luminance of each of the regions shown in FIG. 41 and those of leakage light that is emitted from the surrounding regions into each region, and are calculated by Eq. (6) shown in FIG. 13A, where $n=8$. Also in FIG. 42, relative light emission luminances are used for convenience.

[0177] In FIG. 42, light emission luminances B_1' to B_8' are maximum in regions 35d' and 35e' and minimum in regions 35a' and 35h'. This is due to a decrease in the number of nearby regions to the left of a given region as one moves left from 35d' and likewise a decrease in the number of regions to the right of a given region as one moves right from 35e'.

[0178] FIG. 43A is a view showing an example of an image pattern when image signals with a uniform gradation are displayed on liquid crystal panel 34. FIG. 43B is a view showing the display luminance in one line of the image pattern shown in FIG. 43A. FIG. 44A is a view showing an example of an image pattern on liquid crystal panel 34 when the image signals with a uniform gradation shown in FIG. 43A are inputted into image signal processor 10 (100) and the image signals are processed based on the light emission luminances of backlight device 35 shown in FIG. 42. FIG. 44B is a view showing the display luminance in one line of the image pattern shown in FIG. 44A.

[0179] As shown in FIGS. 43A and 43B, the light emission luminances of region 35a' in the upper end of backlight device 35 and region 35h' in the lower end thereof are larger than the light emission luminances of regions 35d' and 35e' which are positioned in the center of backlight device 35. This is because reflection at an end of backlight device 35 is not considered for obtaining the light emission luminances shown in FIG. 42.

[0180] For this reason, as shown in FIG. 45, virtual region 35a'' and virtual region 35h'' are respectively virtually provided in an upper portion of region 35a' in an upper end of backlight device 35C and in a lower portion of region 35h' in the lower end thereof, so that light emission luminance calculator 22 calculates light emission luminances B_1' to B_8' . Eq. (36) shown in FIG. 46 represents a matrix equation which

more specifically is a conversion equation for obtaining light emission luminances B_0' to B_9' from light emission luminances B_{01} to B_{09} right above light sources 352 when respective light sources 352 in regions 35a' to 35h' emit light individually. Note that light emission luminance B_{00} is the light emission luminance of light right above light source 352, assuming that light source 352 in virtual region 35a'' emits light individually, and light emission luminance B_{09} is the light emission luminance of light right above light source 352, assuming that light source 352 in virtual region 35h'' emits light individually. In addition, light emission luminance B_0' is the light emission luminance of light assumed to be emitted from virtual region 35a'' and light emission luminance B_9' is the light emission luminance of light assumed to be emitted from virtual region 35h''.

[0181] FIG. 47 is a view showing light emission luminances B_0' to B_9' of light emitted from regions 35a' to 35h' into which backlight device 35C is divided in the vertical direction. Here, light emission luminances B_0' to B_9' are calculated by using Eq. (36) shown in FIG. 46. As shown in FIG. 47, the light emission luminances in region 35a' in the left end, region 35h' in the right end, and regions in the vicinities thereof are higher than those in FIG. 41. That is, by calculating light emission luminances using virtual regions 35a'' and 35h'', reflection at the ends is taken into account.

[0182] FIGS. 48A and 48B show an image pattern and display luminance in one line of the image pattern. The image pattern is displayed on liquid crystal panel 34 when image signals of the image pattern with a uniform gradation as shown in FIG. 43A are inputted to image signal processor 10 (100) and the image signals are processed based on the light emission luminances shown in FIG. 47. As shown in FIGS. 48A and 48B, the display luminance on liquid crystal panel 34 is image signals with a substantially uniform gradation, which is supposed to be displayed.

[0183] Eq. (37) shown in FIG. 49A represents a matrix equation which more specifically is a conversion equation for obtaining light emission luminances B_0' to B_9' from light emission luminances B_{01} to B_{09} . Eq. (38) shown in FIG. 49B is, similar to Eq. (3) shown in FIG. 11, obtained by rearranging Eq. (37) to make it easy to perform a calculation in a circuit of light emission luminance calculator 22. Eq. (39) shown in FIG. 49C shows constants a, b, and c. As seen in Eq. (38) in FIG. 49B, each of light emission luminances B_{01} to B_{09} can be obtained by multiplying each of light emission luminance B_0' to B_9' by a coefficient (conversion coefficient) based on the amount of light which is emitted from light source 352 of each of regions 35a' to 35h', 35a'' and 35h'' and leaked out to other regions other than a corresponding region.

[0184] Since the light leaked from one region in backlight device 35 to nearby regions can be measured, the value of the attenuation coefficient k expressed in Eq. (39) in FIG. 49C can be determined in advance. Accordingly, expected light luminances B_{01} to B_{09} of light to be emitted by each of light sources 352 in regions 35a' to 35h', 35a'', and 35h'' can be accurately calculated. Note that light emission luminance B_{00} of light which is supposed to be emitted from light source 352 in virtual region 35a'' and light emission luminance B_{09} of light which is supposed to be emitted from light source 352 in virtual region 35h'' are not light sources which are supposed to emit light. Thus, calculation is not needed.

[0185] Further, when generalizing the above, i.e., when backlight device 35 is divided into n regions in the vertical direction (n: a positive integer being equal to 2 or greater),

light emission luminances B_0' to B_{n+1}' are obtained by Eq. (40) shown in FIG. 50A, and light emission luminances B_0 to B_{n+1} can be calculated using Eq. (41) shown in FIG. 50B. In the sixth embodiment, the configuration in which a virtual region is provided in each of the upper and lower portions is described. However, in the case where backlight device 35 is one-dimensionally divided into multiple regions in the horizontal direction, it is preferable that a virtual region be provided in each of the left portion of the left end region and the right portion of the right end region. In addition, two or more virtual regions may be provided in the same direction, and the number of one-dimensionally divided regions of backlight device 35 is not limited to 8. Further, backlight device 35 may be divided into multiple divisions in two dimensions. In this case, it is preferable that a virtual region be provided in each of four directions in an upper portion of the upper end region, a lower portion of the lower end region, a left portion of the left end region, and a right portion of the right end region.

Seventh Embodiment

[0186] FIG. 51 is a block diagram showing an entire configuration of the liquid crystal display device of the seventh embodiment. In FIG. 51, the parts, which are the same as those shown in FIGS. 1, 21, 26 and 34 are given the same reference numerals, so that a further description thereof may be omitted. Accordingly, in the seventh embodiment, image signal processor 300 including histogram detector 16 is provided instead of image signal processor 10.

[0187] Further, for the sake of simplicity, non-uniformization processor 21 in FIG. 1 is eliminated from FIG. 51, but may be included as in the first embodiment. Further, light emission amount calculator 25 is included in FIG. 51 as in the second and third embodiments, but also may be eliminated. Further, for the sake of simplicity, luminance bitmap memory 15 is eliminated from FIG. 34, but may be included as in the fifth embodiment. The seventh embodiment enables reduction of the backlight power consumption by lowering backlight luminance even for high-luminance image signals containing some amount of high-frequency luminance components.

[0188] For example, backlight device 35B shown in FIGS. 5A, 5B, and 5C is divided into sixteen regions, regions 35a1 to 35a4, 35b1 to 35b4, 35c1 to 35c4, and 35d1 to 35d4, with partition walls 353 in the horizontal and vertical directions, in a rectangular housing 351 having predetermined depth. The liquid crystal panel 34 is divided into regions, 34a1 to 34a4, 34b1 to 34b4, 34c1 to 34c4, and 34d1 to 34d4 corresponding to respective regions of backlight device 35, regions 35a1 to 35a4, 35b1 to 35b4, 35c1 to 35c4, and 35d1 to 35d4.

[0189] Histogram detector 16 detects image signal gradation within regions 34a1 to 34a4, 34b1 to 34b4, 34c1 to 34c4, and 34d1 to 34d4. Both pixel ratio lower than predetermined gradation level and pixel ratio higher than predetermined gradation level of image signal are detected for each region. The pixel ratio lower than predetermined gradation level is called low gradation pixel ratio and the pixel ratio higher than predetermined gradation level is called high gradation pixel ratio. Subsequently, data of low gradation pixel ratio and high gradation pixel ratio are supplied to image gain calculator 12.

[0190] FIG. 52 is a flow chart showing the operation of histogram detector 16 to obtain gain data for image gain calculator 12, which is multiplied by the image signal for supply to multiplier 14. In step S41 the following are input into image gain calculator 12: 1) maximum gradation of

image signal G_{max1} , detected respectively per regions, 35a1 to 35a4, 35b1 to 35b4, 35c1 to 35c4 and 35d1 to 35d4 in maximum gradation detector 11, and 2) low gradation pixel ratio and high gradation pixel ratio detected in histogram detector 16.

[0191] A threshold TH1 is set to detect the level of the high-frequency component contained in the image signal. Step S42 determines if the maximum gradation G_{max1} in the respective regions is higher than or equal to the predetermined threshold value TH1. When the maximum gradation G_{max1} is lower than the threshold value TH1 in step S42, there is no need to lower the backlight luminance since the high-frequency component does not exist. Thus, it is treated in the manner shown in the first embodiment in step S46. To be more precise, assume that G_{max0} denotes a possible maximum gradation of an image signal, determined the number of bits in the image signal. G_{max0}/G_{max1} a gain to multiply the image signal is supplied to multiplier 14. Its inverse, G_{max1}/G_{max0} , is used to control the luminance of the backlights in light emission luminance calculator 22 in backlight luminance controller 20.

[0192] In step S42, when maximum gradation G_{max1} is higher than or equal to the threshold value TH1, step 43 determines if low gradation pixel ratio, detected in histogram detector 16, is higher than predetermined threshold value RH. FIGS. 53A, 53B, 53C and 53D show the examples of histograms and image patterns when image signals inputted to histogram detector 16 are displayed on liquid crystal panel 34.

[0193] FIGS. 53A to 53D are graphs for describing the image pattern histogram displayed on the liquid crystal panel. FIGS. 53A and 53B are both examples of image patterns: a region with hatching indicates gradation 0 pixels, a white region indicates gradation 255 pixels and a dashed line indicates border line between the respective regions, 34a1 to 34a4, 34b1 to 34b4, 34c1 to 34c4 and 34d1 to 34d4. The bit count of the image signal is 8 bits (maximum gradation 255). FIG. 53C indicates the histogram obtained from the image pattern in the region of 34d4 in FIG. 53A. FIG. 53D indicates the histogram obtained by the image pattern in the region of 34d4 in FIG. 53B.

[0194] A histogram is a graphical representation of the luminance and gradation distribution in an image and is a plot of the numbers of pixels for each gradation level. The horizontal axis of the histogram represents the gradation level: the left end region corresponds to black and right end region corresponds to white. The vertical axis represents the level of the numbers of pixels when the sum of the pixels in each region is 1. In FIGS. 53C and 53D, for example, gradation levels are shown in 8 different levels in histogram, but it is not limited to that.

[0195] For example, a low gradation pixel ratio can be obtained from numbers of pixels that have gradation from 0 to 31 in one region, divided by total numbers of pixels of the region. Further, the low gradation pixel ratio is not limited to the gradation from 0 to 31. However, the gradation is lower or equal to 127 when maximum gradation is 255. For example, when threshold value RH is set as 0.25, both low gradation pixel ratios are higher or equal to threshold value RH in image patterns shown in FIGS. 53A and 53B. That is, the display of the image signal includes more dark portions in low gradation (black or nearly black). Therefore, when the low gradation pixel ratio is higher or equal to threshold value RH, step S44 determines if high gradation pixel ratio is lower or equal to

predetermined threshold value RL. When, step S43 detects that low gradation pixel ratio is lower than threshold RH, the overall image signal gradation is not low. Therefore, when the low gradation pixel ratio is lower than threshold value RH, the same method as in the first embodiment is processed in step S46.

[0196] High gradation pixel ratio is the ratio obtained from numbers of pixels that have gradation from 224 to 255 in one region, divided by total numbers of pixels of the region. The high gradation pixel ratio is not limited to the gradation from 224 to 255. However, the gradation is higher than 128 when maximum gradation is 255. For example, when threshold value RL is set as 0.1, high gradation pixel ratio in FIG. 53A is higher than threshold value RL and high gradation pixel ratio in FIG. 53B is lower than or equal to threshold value RL.

[0197] As shown in an image pattern in FIG. 53A, when high gradation pixel ratio in step S44 is higher than threshold RL, the image signal is likely to have both dark (typically black) portion of low gradation and light (typically white) portion of gradation mixed. Therefore, when the high gradation pixel ratio is higher than threshold value RL, the same method as in the first embodiment is processed in step S46.

[0198] In image pattern shown in FIG. 53B, when high gradation pixel ratio is lower or equal to threshold value RL in step 44, the image signal is considered to have some amount of high-frequency component in overall low gradation and dark portions. Therefore, when it is lower or equal to threshold value RL, step S45 provides gain r to multiplier 14, which multiplies gain r by the image signal. $1/r$, which is an inverse number of the gain r, is used to control the luminance of the backlights in light emission luminance calculator 22 of backlight luminance controller 20. Preferably, the value of r is smaller than the value of G_{max0}/G_{max1} . For example, when the value of G_{max0}/G_{max1} is 1, the value of r may be 0.1.

[0199] Furthermore, image gain calculator 12 is not limited to have a fixed value of gain r for every image pattern. For example, gain can be calculated from equation (42) shown in FIG. 54. In equation (42), R_b indicates low gradation pixel ratio, R_w indicates high gradation pixel ratio and C_o indicates a constant. In addition, Eq. (42) can be used for either low gradation pixel ratio R_b or high gradation pixel ratio R_w . Thus, backlight electric power consumption can be reduced in the case of the image signal consisting of mostly low gradation and dark portions and some amount of high-frequency component in the image signal.

[0200] The seventh embodiment is described as the structure for detecting high gradation pixel ratio, which can be considered as almost white. However, high gradation pixel ratio may be further adjusted to the pixel ratio close to the peak level, the maximum gradation G_{max1} . In such case, the pixel ratio close to the peak level can be determined as lower than or equal to threshold RL in step S44. When the image signal has no high frequency components step 44 can be omitted. Furthermore, the seventh embodiment is described as having a configuration wherein image signals are multiplied by a gain and backlights are multiplied by the inverse of the gain.

[0201] As described in the above embodiments of the liquid crystal display device and the image display method, the quality of the displayed images can be improved by eliminating uneven brightness and color in the edge of image by dividing the backlight device into multiple regions and by

controlling the light emission luminance of the backlights in each respective region corresponding to the brightness of the image signal.

[0202] It is to be understood that the invention is not limited to the above described first to seventh embodiments, and various changes may be made therein without departing from the spirit of the present invention. Although liquid crystal panel 34 and backlight device 35 of the first to seventh embodiments are assumed to have multiple regions of the same area, the regions may be intentionally set to different dimensions. Further, when an image display device, which needs a backlight device, is newly developed other than liquid crystal display devices, it is naturally possible to apply the present invention to such an image display device.

[0203] It is to be understood that the present invention is not limited to the above-described first to sixth embodiments, and various changes may be made therein without departing from the spirit of the present invention. Although liquid crystal panel 34 and backlight device 35 of the first to sixth embodiments are assumed to have multiple regions of the same area, the regions may be intentionally set to have different areas. Further, when an image display device which needs a backlight device is newly developed other than liquid crystal display devices, it is naturally possible to apply the present invention to such an image display device.

[0204] The invention includes other embodiments in addition to the above-described embodiments without departing from the spirit of the invention. The embodiments are to be considered in all respects as illustrative, and not restrictive. The scope of the invention is indicated by the appended claims rather than by the foregoing description. Hence, all configurations including the meaning and range within equivalent arrangements of the claims are intended to be embraced in the invention.

What is claimed is:

1. A liquid crystal display device, comprising:
 - a liquid crystal panel configured to display an image from image signals;
 - a backlight device disposed on the back side of the liquid crystal panel, and divided into a plurality of regions, the backlight device comprising light sources in each of the regions, wherein the light sources are positioned to emit light onto the liquid crystal panel;
 - a histogram detector configured to detect an image signal gradation distribution for each region and to produce a histogram therefrom;
 - an image gain calculator configured to calculate a gain from the detected gradation distribution of the histogram detector, and to control light emission from each light source in each region of the backlight device, and
 - a light emission luminance calculator configured to control the light emission luminance of each light source based on a maximum luminance of the light sources and based on an inverse number of the gain calculated in the image gain calculator.
2. The liquid crystal display device of claim 1, further comprising a multiplier configured to output to the liquid crystal panel the result of multiplication of the image signals of each region and the gain obtained by the image gain calculator.
3. The liquid crystal display device of claim 1, wherein the histogram detector detects at least one of a plurality of pixel ratios from the histogram of the image signal gradation distribution, the plurality of pixel ratios includes a pixel ratio

lower than a first predetermined gradation and a pixel ratio higher than a second predetermined gradation.

4. The liquid crystal display device of claim 3, further comprising a maximum gradation detector configured to detect a first maximum gradation of the image signal from the backlight device regions, at predetermined intervals, wherein the image gain calculator determines if a value of pixel ratio lower than the first predetermined gradation is more than or equal to a first threshold value,

when the value of pixel ratio lower than the first predetermined gradation is more than or equal to the first threshold value, the gain is set to a predetermined value based on the value of pixel ratio lower than the first predetermined gradation,

when the value of pixel ratio lower than the first predetermined gradation is less than the first threshold value, the gain is set to a value calculated by dividing a second maximum gradation of the image signal gradation distribution by the first maximum gradation, wherein the second maximum gradation is determined by the number of bits of the image signal.

5. The liquid crystal display device of claim 4, wherein the image gain calculator determines if the value of pixel ratio lower than the first predetermined gradation is more than or equal to the first threshold value, and if the value of pixel ratio higher than the second predetermined gradation is less than the second threshold value, when the value of pixel ratio lower than the first predetermined gradation is more than or equal to the first threshold value and the value of pixel ratio higher than the second predetermined gradation is less than the second threshold value, the value of the gain is set to one of a predetermined value and a value based on the pixel ratio, when the value of pixel ratio lower than the first maximum gradation is less than the first threshold value, or the value of pixel ratio higher than the second predetermined gradation is more than or equal to the second threshold value, the value of the gain is calculated by dividing a second maximum gradation of the image signal gradation distribution by the first maximum gradation, wherein the second maximum gradation is determined by the number of bits of the image signal.

6. The liquid crystal display device of claim 1, wherein the backlight device is configured to allow light emitted from the light source of each of the plurality of regions to leak to nearby regions, wherein

the light emission luminance calculator calculates a second light emission luminance by multiplying a first light emission luminance by a coefficient that is based on light leaked from nearby regions, wherein

the first light emission luminance is light emission luminance emitted from each region in the backlight device is calculated by multiplying the maximum luminance of the light source by the inverse of the gain calculated by the image gain calculator, and

the second light emission luminance is light emission luminance emitted by each light source of the regions in the backlight device to obtain the first light emission luminance.

7. An image display method comprising:

obtaining, as image signals for display on a liquid crystal panel, an image signal per each region of a first set on the liquid crystal panel;

detecting a histogram of the gradation distribution of image signals per each region of the first set;

calculating a gain based on the detected histogram, in order to control light emission luminance of a backlight device, the backlight device being divided into second set of regions corresponding to the first set of regions of the liquid crystal panel;

displaying an image according to the image signal per region of the liquid crystal panel while causing each light source in respective regions of the backlight device to emit light emission luminance based on a maximum luminance of the light sources and an inverse of the gain.

8. The method of claim 7, wherein respective regions of the backlight device emit light emission luminance based on a value obtained by multiplying the maximum luminance of the light sources by the inverse of the gain.

9. The method of claim 7, wherein detecting the histogram of gradation distribution includes detecting at least one of a plurality pixel ratios from the histogram gradation distribution, the plurality of pixel ratio includes a pixel ratio lower than or equal to a first predetermined gradation and a pixel ratio higher than or equal to a second predetermined gradation.

10. The method of claim 7, further comprising:

detecting a first maximum gradation of the gradation distribution of image signals per each of the first plurality of regions, at predetermined intervals; wherein the calculating the gain, comprising:

determining if the value of pixel ratio lower than the first gradation is more than or equal to a first threshold value;

setting the gain to a predetermined value based on the value of pixel ratio lower than the first predetermined gradation, when the value of pixel ratio lower than the first predetermined gradation is more than or equal to a first threshold value,

; and

setting the gain to a value by dividing a second maximum gradation of the image signal by the first maximum gradation, when the value of pixel ratio lower than the first predetermined gradation is less than the first threshold value, wherein the second maximum gradation is determined by the number of bits of the image signal.

11. The method of claim 10, wherein calculating the gain comprises:

determining if the value of pixel ratio lower than the first predetermined gradation is more than or equal to the first threshold value, and if the value of pixel ratio higher than the second predetermined gradation is less than the second threshold value,

setting the value of the gain to a predetermined value based on the pixel ratio, when the value of pixel ratio lower than the first predetermined gradation is more than or equal to the first threshold value and the value of pixel ratio higher than the second predetermined gradation is less than the second threshold value,

setting the value of the gain to a value that is calculated by dividing a second maximum gradation of the image signal by the first maximum gradation, when the value of pixel ratio lower than the first predetermined gradation is less than the first threshold value, or the value of pixel ratio higher than the second predetermined gradation is more than or equal to the second threshold value,

wherein the second maximum gradation is determined by the number of bits of the image signal.

12. The method of claim 7, wherein the backlight device is configured to allow light emitted from the light source of each of the plurality of regions to leak to nearby regions, wherein the image displaying comprises:

calculating a second light emission luminance by multiplying a first light emission luminance by a coefficient that is based on light leaked from nearby regions, wherein the first light emission luminance that emitted from each region in the backlight device is calculated by multiplying the maximum luminance

of the light source by the inverse of the gain calculated by the image gain calculator, and wherein the second light emission luminance is light emitted by each light source of the regions in the backlight device to obtain the first light emission luminance; and

displaying an image according to the image signal per region of the liquid crystal panel while causing each light source in respective regions of the backlight device to emit light at the second light emission luminance.

* * * * *

专利名称(译)	液晶显示装置及其图像显示方法		
公开(公告)号	US20100066752A1	公开(公告)日	2010-03-18
申请号	US12/504623	申请日	2009-07-16
[标]申请(专利权)人(译)	日本胜利株式会社		
申请(专利权)人(译)	VICTOR COMPANY OF JAPAN , LIMITED		
当前申请(专利权)人(译)	JVC建伍公司		
[标]发明人	WATANUKI KATSUMI		
发明人	WATANUKI, KATSUMI		
IPC分类号	G09G3/36 G09G5/02		
CPC分类号	G09G3/3426 G09G3/3611 G09G2310/0232 G09G2320/0233 G09G2320/0276 G09G2320/0285 G09G2360/16 G09G2320/043 G09G2320/0646 G09G2320/0666 G09G2330/021 G09G2360/145 G09G2320/041		
优先权	2008239039 2008-09-18 JP		
其他公开文献	US8421740		
外部链接	Espacenet USPTO		

摘要(译)

液晶面板显示来自图像信号的图像。背光装置设置在液晶面板的背面，并且被分成多个区域。背光装置包括每个区域中的光源。定位光源以将光发射到液晶面板上。直方图检测器检测每个区域的图像信号灰度分布并从中产生直方图。图像增益计算器根据检测到的直方图检测器的灰度分布计算增益，并控制来自背光装置的每个区域中的每个光源的光发射。发光亮度计算器基于光源的最大亮度并基于在图像增益计算器中计算的增益的倒数来控制每个光源的发光亮度。

