



(19) **United States**

(12) **Patent Application Publication**  
**Hung**

(10) **Pub. No.: US 2007/0216619 A1**

(43) **Pub. Date: Sep. 20, 2007**

(54) **LIQUID CRYSTAL DISPLAY**

**Publication Classification**

(75) Inventor: **Meng-Yi Hung, Hsin-Chu (TW)**

(51) **Int. Cl.**  
**G09G 3/36** (2006.01)

Correspondence Address:  
**THOMAS, KAYDEN, HORSTEMEYER & RIS-  
LEY, LLP**  
**100 GALLERIA PARKWAY, NW, STE 1750**  
**ATLANTA, GA 30339-5948**

(52) **U.S. Cl.** ..... **345/87**

(57) **ABSTRACT**

A liquid crystal display has a pixel array including first and second pixel electrodes. Each of the first pixel electrodes is divided into at least two first sub-pixel electrodes in two pixel areas sharing a corner or an edge. Similarly, each of the second pixel electrodes is divided into at least two second sub-pixel electrodes in two pixel areas sharing a corner or an edge. The polarities of the first and the second electrodes are opposite. The first and the second pixel electrodes are arranged alternatively to allow at least one first sub-pixel electrode and at least a second sub-pixel electrode to be located in each pixel area.

(73) Assignee: **AU OPTRONICS CORPORATION, Hsin-Chu (TW)**

(21) Appl. No.: **11/684,762**

(22) Filed: **Mar. 12, 2007**

(30) **Foreign Application Priority Data**

Mar. 17, 2006 (TW) ..... 95109332

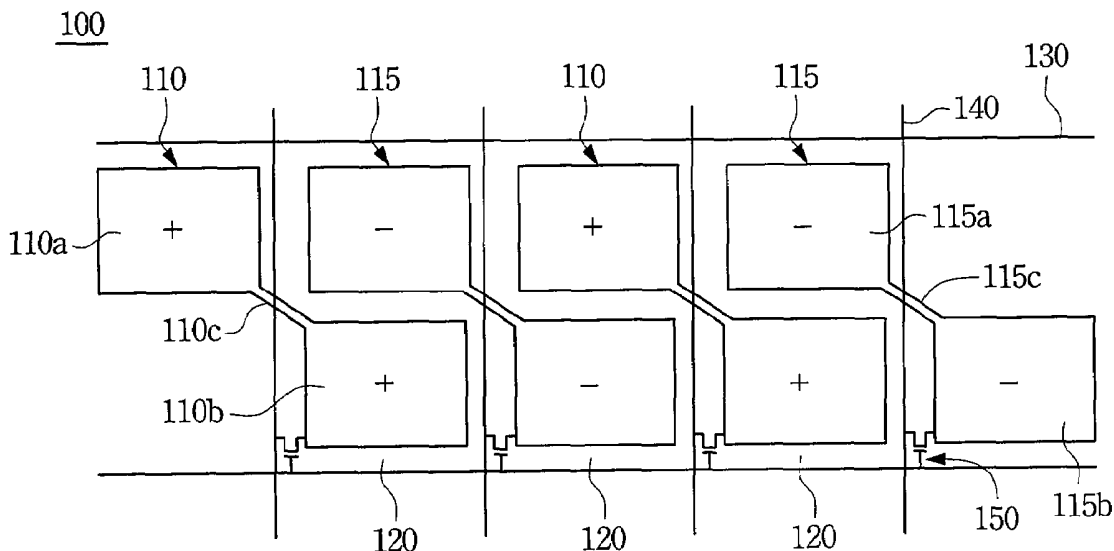



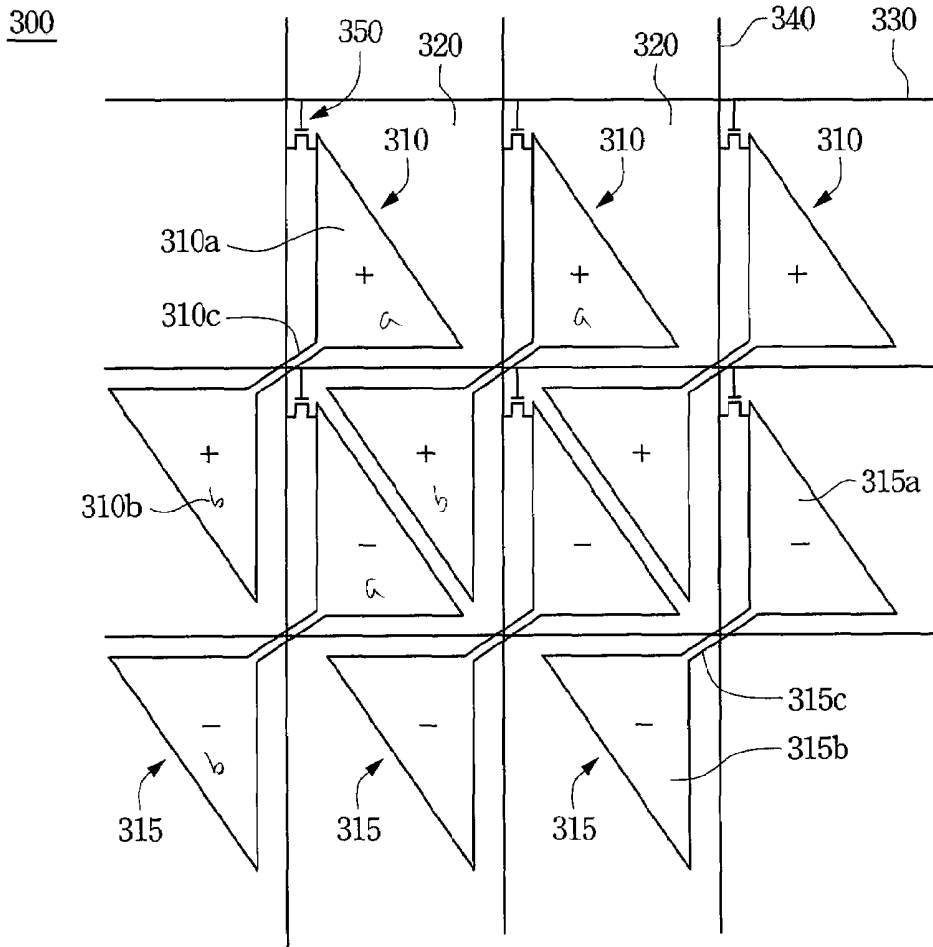

Fig. 3

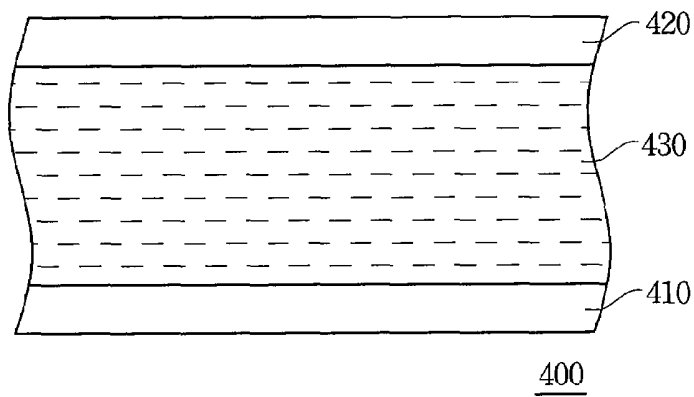

Fig. 4

## LIQUID CRYSTAL DISPLAY

### RELATED APPLICATIONS

**[0001]** This application claims priority to Taiwan Application Serial Number 95109332, filed Mar. 17, 2006, which is herein incorporated by reference.

### BACKGROUND

**[0002]** 1. Field of Invention

**[0003]** The present invention relates to a liquid crystal display. More particularly, the present invention relates to a liquid crystal display containing sub-pixel electrodes.

**[0004]** 2. Description of Related Art

**[0005]** Very wide viewing angles and high definition, among others, are the advantages of a multi-domain vertical alignment (MVA) liquid crystal display (LCD). Some slits and protrusions are formed on the inner surfaces of two transparent substrates in a conventional MVA LCD in which vertically aligned liquid crystal molecules are tilted symmetrically in opposite directions to compensate for viewing angles.

**[0006]** As disclosed in U.S. Pat. No. 6,922,183 (hereinafter, the "183 patent"), the lateral electric field applied to the slits on the inner surface of the transparent electrode of an MVA LCD has to be increased, so the liquid crystal molecules in the proximity of the slit can be inclined efficiently and liquid crystal molecular response time can be reduced. A pixel electrode is divided into two sub-pixel electrodes, and thus a pixel is divided into two sub-pixels. The two equipotential sub-pixel electrodes with opposite polarities are electrically isolated to each other by the slit. Lateral electric field is created on the slits to reduce response time of liquid crystal molecules.

**[0007]** However, the invention disclosed by the '183 patent requires each of two sub-pixel electrodes to be connected with a switch as a driving device for the corresponding sub-pixel. The number of driving devices for each pixel is thus doubled. In addition, sub-pixels with opposite polarities must have their own contact holes to conduct their own electronic signals. When a pixel electrode is divided into several sub-pixel electrodes, sub-pixel electrodes with the same polarity have to be connected by additional wire in order to use one single switch as the driving device. The additional wire will increase both the complexity of electric circuit and the difficulty of manufacturing process.

### SUMMARY

**[0008]** An LCD is provided. The pixel electrode array of the LCD comprises plural first pixel electrode and plural pixel electrode having opposite polarities.

**[0009]** Each of the first pixel electrode comprises a first connecting part and two first sub-pixel electrodes located in two adjacent pixel areas. Each first sub-pixel electrode has at least three corners. The two first sub-pixel electrodes are diagonally connected through the first connecting part at respective corners of the two first sub-pixel electrodes and separately located on one of the first pixel area and one of the second pixel area located adjacently.

**[0010]** Similarly, each of the second pixel electrode comprises a second connecting part and two second sub-pixel electrodes located in two adjacent pixel areas. Each second sub-pixel electrode has at least three corners. The two second sub-pixel electrodes are diagonally connected

through the second connecting part at respective corners of the two second sub-pixel electrodes and separately located on one of the first pixel area and one of the second pixel area located adjacently in such a manner that one of the two first sub-pixel electrodes and one of the two second sub-pixel electrodes are disposed side by side. Hence, each pixel area comprises at least a first sub-pixel electrode and a second sub-pixel electrode.

**[0011]** Plural first switches are located on the first pixel areas to control the first pixel electrodes, respectively. Plural second switches are located on the second pixel areas to control the second pixel electrodes, respectively.

**[0012]** Accordingly, pixel electrode is divided into several structurally connected sub-pixel electrodes and only one driving switch device is required for one pixel electrode. Furthermore, the first sub-pixel electrode and the second sub-pixel electrode are alternatively arranged. Same electric potential with opposite polarities can be applied to neighboring first pixel electrode and second pixel electrode. At least one first sub-pixel electrode and one second sub-pixel electrode can be formed in each pixel area without additional signal line and driving switch device.

**[0013]** It is to be understood that both the foregoing general description and the following detailed description are by examples, and are intended to provide further explanation of the invention as claimed.

### BRIEF DESCRIPTION OF THE DRAWINGS

**[0014]** The present invention can be more fully understood by reading the following detailed description of the embodiment, with reference made to the accompanying drawings as follows:

**[0015]** FIG. 1 illustrates the pixel array of an LCD according to an embodiment of the present invention;

**[0016]** FIG. 2 illustrates the pixel array of an LCD according to another embodiment of the present invention;

**[0017]** FIG. 3 illustrates the pixel array of an LCD according to another embodiment of the present invention; and

**[0018]** FIG. 4 illustrate a cross sectional view of a conventional LCD.

### DETAILED DESCRIPTION

**[0019]** Accordingly, this invention provides an LCD, each pixel electrode of the LCD is divided into several sub-pixel electrodes. The two neighboring sub-pixel electrodes in the same pixel have opposite polarities. The number of switch devices does not need to be increased. Only conventional signal line and switch device are required to obtain two neighboring sub-pixel electrodes with opposite polarities in the same pixel. The LCD response time can thus be reduced.

#### Embodiment 1

**[0020]** FIG. 1 illustrates the pixel array of an LCD according to an embodiment of the invention. The pixel array **100** comprises pixel electrodes **110** and **115**. The pixel electrode **110** comprises two sub-pixel electrodes **110a** and **110b**. The sub-pixel electrodes **110a**, **110b** are formed in two neighboring pixel areas **120** sharing an edge and diagonally connected to each other through a connecting part **110c**. Similarly, pixel electrode **115** comprises two sub-pixel electrodes **115a** and **115b**. The sub-pixel electrodes **115a** and **115b** are formed in two neighboring pixel areas **120** sharing an edge and diagonally connected to each other through a

connecting part **115c**. Therefore, a repeating unit of the pattern formed by the first sub-pixel electrodes **110a**, **110b** and the second sub-pixel electrodes **115a**, **115b** is two first sub-pixel electrodes **110a**, **110b** in the two diagonal areas of a parallelogram and two second sub-pixel electrodes **115a**, **115b** in the other two diagonal areas of the parallelogram.

[0021] Each of the above mentioned pixel area **120** is defined by a pair of scan lines **130** and a pair of data lines **140**. A switch device **150** is formed in one corner of the pixel area **120**. The switch device **150** of this embodiment is a thin film transistor with a gate, a source and a drain connected to the scan line **130**, the data line **140**, the sub-pixel electrode **110b** or **115b**, respectively.

[0022] The pixel electrodes **110**, **115** shown in FIG. 1 are formed on a switch device substrate alternatively. The two neighboring pixel electrodes **110**, **115** can be controlled to have opposite polarities, so that one pixel area **120** comprising two sub-pixel electrodes **110b**, **115a** (or **110a**, **115b**) with opposite polarities can be obtained. The sub-pixel electrodes **110b**, **115a** (or **110a**, **115b**) in one pixel area **120** belong to two different pixel electrodes **115**, **110**. Because, for example, the two sub-pixel electrodes (**110a**, **110b**) or (**115a**, **115b**) of one pixel electrode **110** or **115** are still connected to each other, only one switch device is required to drive the pixel electrodes **110**, **115**. In addition, dot inversion method or any appropriate method can be used to allow the two neighboring pixel electrodes **110**, **115** to have opposite polarities.

#### Embodiment 2

[0023] FIG. 2 illustrates the pixel array of an LCD according to another embodiment of the invention. FIG. 2 shows that pixel array **200** is composed of pixel electrodes **210** and **215**. The pixel electrode **210** is divided into three sub-pixel electrodes **210a**, **210b**, and **210c**. The sub-pixel electrodes **210a**, **210b**, and **210c** are formed in the two neighboring pixel areas **220** sharing an edge. The sub-pixel electrode **210b** is diagonally connected to the sub-pixel electrodes **210a** and **210c** through connecting parts **210d** and **210e**. Similarly, the pixel electrode **215** is divided into three sub-pixel electrodes **215a**, **215b**, and **215c**. The sub-pixel electrodes **215a**, **215b**, and **215c** are formed in the two neighboring pixel areas **22** sharing an edge. The sub-pixel electrode **215b** is diagonally connected to sub-pixel electrodes **215a** and **215c** through connecting parts **215d** and **215e**. Therefore, a repeating unit of the pattern formed by, for example, the first sub-pixel electrodes **210a**, **110b** and the second sub-pixel electrodes **215a**, **215b** is two first sub-pixel electrodes **210a**, **210b** in the two diagonal areas of a parallelogram and two second sub-pixel electrodes **215a**, **215b** in the other two diagonal areas of the parallelogram.

[0024] Each of the above mentioned pixel area **220** is defined by a pair of scan lines **230** and a pair of data lines **240**. In addition, a switch device **250** is formed in one corner of each pixel area **220**. The switch device **250** in this embodiment is a thin film transistor with a gate, a source and a drain connected to the scan line **230**, the data line **240** and the sub-pixel electrode **210c** or **215c**, respectively.

[0025] As shown in FIG. 2, the pixel electrodes **210** and **215** are alternatively formed on a switch device substrate. The three sub-pixel electrodes **210a**, **215b**, **210c** (or **215a**, **210b**, **215c**) within the same pixel area **220** have opposite polarities between the sub-pixel electrodes **210a**, **210c** (or **215a**, **215c**) and the sub-pixel electrode **215b** (or **210b**)

when the neighboring pixel electrode **210** and the pixel electrode **215** have opposite polarities. Although the sub-pixel electrodes **210a**, **210b**, **210c** of the pixel electrode **210** are arranged in two pixel areas **220** sharing an edge, the sub-pixel electrodes **210a**, **210b**, **210c** of the pixel electrode **210** are connected through the connecting parts **210d** and **210e**. Hence, only one switch device **250** is required for the pixel electrode **210**. Similarly, the sub-pixel electrodes **215a**, **215b**, **215c** of the pixel electrode **215** are also connected through the connecting parts **215d** and **215e**; hence only one switch device **250** is required for the pixel electrode **215**. The way to obtain two neighboring pixel electrodes **210**, **215** with opposite polarities can be, for example, dot inversion.

#### Embodiment 3

[0026] FIG. 3 illustrates the pixel array of an LCD according to another embodiment of the invention. The pixel array **300** is composed of pixel electrodes **310** and **315**. The pixel electrode **310** is divided into two sub-pixel electrodes **310a** and **310b** located in two pixel areas **320** sharing a corner. The sub-pixel electrodes **310a** and **310b** are connected to each other through a connecting part **310c**. Similarly, pixel electrode **315** comprises two sub-pixel electrodes **315a**, **315b** located in two pixel areas **320** sharing a corner. The sub-pixel electrodes **315a** and **315b** are connected to each other through a connecting part **315c**. Therefore, a repeating unit of a pattern formed by the first sub-pixel electrodes **310a**, **310b** and the second sub-pixel electrodes **315a**, **315b** is two first sub-pixel electrodes **310a**, **310b** located in the two opposite edges of a parallelogram and two second sub-pixel electrodes **315a**, **315b** located in the other two opposite edges of the parallelogram.

[0027] The above mentioned pixel area **320** is defined by a pair of scan line **330** and a pair of data line **340**. A switch device **350** is formed in one corner of the pixel area **320**. The switch device **350** in this embodiment is a thin film transistor with a gate, a source and a drain connected to the scan line **330**, the data line **340**, the sub-pixel electrode **310a** or **315a**, respectively.

[0028] The pixel electrodes **310**, **315** shown in FIG. 3 are formed on a switch device substrate alternatively. The two neighboring pixel electrodes **310**, **315** can be controlled to have opposite polarities, so that the same pixel area **320** comprising two sub-pixel electrodes **310b**, **315a** (or **315b**, **310a**) with opposite polarities can be obtained. Although the two sub-pixel electrodes **310b**, **315a** (or **315b**, **310a**) in one pixel area **320** belong to two different pixel electrodes **315** and **310**, the two sub-pixel electrodes **310a**, **310b** (or **315a**, **315b**) belonged the pixel electrode **310** (or **315**) are still connected to each other through the connecting part **310c**. Hence, only one switch device is required to drive the pixel electrode **310** (or **315**). In addition, dot inversion method or any appropriate method can be used to allow the two neighboring pixel electrodes **310**, **315** to have opposite polarities.

[0029] The above mentioned pixel array structure can be applied to any flat panel display, for example, LCD. Referring to FIG. 4, an LCD **400** comprises a lower substrate **410**, an upper substrate **420** and a liquid crystal layer **430** disposed therebetween. There are many possible modifications for the lower substrate **410** and the upper substrate **420** of recent LCD **400** products. For the first example, the upper substrate **420** can be a color filter if the lower substrate **410** is a control circuit board. For the second example, the

control circuit board and the color filter layer can be formed on the lower substrate **410**, and there is only a common electrode layer on the upper substrate **420**. Based on the location of the control circuit and the color filter, the structure can be either COA (Color Filter on Array) or AOC (Array on Color Filter). The detailed structures of COA and AOC are not shown in FIG. **4** because these possible modifications are apparent to those skilled in the art.

**[0030]** Accordingly, the pixel electrode is only divided into several structurally connected sub-pixel electrodes. Only one driving switch device is required for one pixel. Furthermore, pixel electrodes with opposite polarities are alternatively arranged. At least two sub-pixel electrodes can be formed on each pixel area without additional signal line and driving switch device.

**[0031]** It will be apparent to those skilled in the art that various modifications and variations can be made to the structures of the present invention without departing from the scope or spirit thereof. In view of the foregoing, it is intended that the present invention cover modifications and variations thereof provided they fall within the scope of the following claims.

What is claimed is:

1. A liquid crystal display (LCD), comprising:

an upper substrate;

a lower substrate comprising a pixel array having plural first pixel areas and plural second pixel areas arranged alternatively, the pixel array comprising:

plural first pixel electrode, each of the first pixel electrode comprising a first connecting part and two first sub-pixel electrodes, each first sub-pixel electrode having at least three corners, the two first sub-pixel electrodes being diagonally connected through the first connecting part at respective corners of the two first sub-pixel electrodes and separately located on one of the first pixel area and one of the second pixel area located adjacently;

plural second pixel electrode, each of the second pixel electrode comprising a second connecting part and two second sub-pixel electrodes, each second sub-pixel electrode having at least three corners, the two second sub-pixel electrodes being diagonally connected through the second connecting part at respective corners of the two second sub-pixel electrodes and separately located on one of the first pixel area and one of the second pixel area located adjacently in such a manner that one of the two first sub-pixel electrodes and one of the two second sub-pixel

electrodes are disposed side by side, wherein the second pixel electrode and the first pixel electrode have opposite polarities; and

a first switch, disposed on the first pixel areas, for controlling the second pixel electrodes, respectively;

a second switch, disposed on the second pixel areas, for controlling the second pixel electrode, respectively;

and

a liquid crystal layer interposed between the upper substrate and the lower substrate.

2. The LCD of claim **1**, wherein the repeating unit of the pattern formed by the first sub-pixel electrodes and the second sub-pixel electrodes is two first sub-pixel electrodes in the two diagonal areas of a parallelogram and two second sub-pixel electrodes in the other two diagonal areas of the parallelogram.

3. The LCD of claim **1**, wherein a repeating unit of a pattern formed by the first sub-pixel electrodes and the second sub-pixel electrodes is two first sub-pixel electrodes located in the two opposite edges of a parallelogram and two second sub-pixel electrodes located in the other two opposite edges of the parallelogram.

4. The LCD of claim **1**, wherein the two adjacent pixel areas sharing a corner.

5. The LCD of claim **1**, wherein the two adjacent pixel areas sharing an edge.

6. The LCD of claim **1**, further comprising a plurality of scan lines and a plurality of data lines connected to the switch devices on the substrate.

7. A liquid crystal display, comprising:

an upper substrate;

a lower substrate comprising a pixel array dividing into a plurality of columns of pixel areas and a plurality of rows of pixel areas, each pixel area comprising:

an upper sub-pixel electrode;

a lower sub-pixel electrode insulated to the upper sub-pixel electrode; and

a TFT switch electrically connected to the lower sub-pixel electrode;

wherein the upper sub-pixel electrode is electrically connected to a lower sub-pixel electrode of a previous column, and the lower sub-pixel electrode is electrically connected to an upper sub-pixel electrode of a next column; and

a liquid crystal layer interposed between the upper substrate and the lower substrate.

\* \* \* \* \*

专利名称(译)	液晶显示器		
公开(公告)号	<a href="#">US20070216619A1</a>	公开(公告)日	2007-09-20
申请号	US11/684762	申请日	2007-03-12
[标]申请(专利权)人(译)	友达光电股份有限公司		
申请(专利权)人(译)	友达光电股份有限公司		
当前申请(专利权)人(译)	友达光电股份有限公司		
[标]发明人	HUNG MENG YI		
发明人	HUNG, MENG-YI		
IPC分类号	G09G3/36		
CPC分类号	G02F2001/134345 G09G3/3614 G09G2300/0447 G09G2300/0426 G09G2300/0443 G09G3/3648		
优先权	095109332 2006-03-17 TW		
其他公开文献	US7924387		
外部链接	<a href="#">Espacenet</a> <a href="#">USPTO</a>		

摘要(译)

液晶显示器具有包括第一和第二像素电极的像素阵列。每个第一像素电极被划分为共享角落或边缘的两个像素区域中的至少两个第一子像素电极。类似地，每个第二像素电极在共享角落或边缘的两个像素区域中被划分为至少两个第二子像素电极。第一和第二电极的极性相反。第一和第二像素电极交替排列，以允许至少一个第一子像素电极和至少第二子像素电极位于每个像素区域中。

