



US 20060114383A1

(19) **United States**

(12) **Patent Application Publication**
Kobayashi et al.

(10) **Pub. No.: US 2006/0114383 A1**

(43) **Pub. Date: Jun. 1, 2006**

(54) **LIQUID CRYSTAL PANEL AND LIQUID CRYSTAL DISPLAY APPARATUS**

(75) Inventors: **Kentarou Kobayashi**, Osaka (JP);
Shuuji Yano, Osaka (JP); **Naoki Koishi**, Osaka (JP)

Correspondence Address:
WESTERMAN, HATTORI, DANIELS & ADRIAN, LLP
1250 CONNECTICUT AVENUE, NW
SUITE 700
WASHINGTON, DC 20036 (US)

(73) Assignee: **NITTO DENKO CORPORATION**,
Ibaraki (JP)

(21) Appl. No.: **11/265,202**

(22) Filed: **Nov. 3, 2005**

(30) **Foreign Application Priority Data**

Nov. 29, 2004 (JP) 2004-344053
Aug. 25, 2005 (JP) 2005-244847

Publication Classification

(51) **Int. Cl.**
G02F 1/1335 (2006.01)
(52) **U.S. Cl.** **349/117**

(57) **ABSTRACT**

A liquid crystal panel according to an embodiment of the present invention includes: a liquid crystal cell; a first polarizer arranged on one side of the liquid crystal cell; a second polarizer arranged on another side of the liquid crystal cell; a negative biaxial optical element and a positive C plate arranged between the liquid crystal cell and the first polarizer; and an isotropic optical element arranged between the liquid crystal cell and the second polarizer. Here, the negative biaxial optical element is arranged between the first polarizer and the positive C plate.

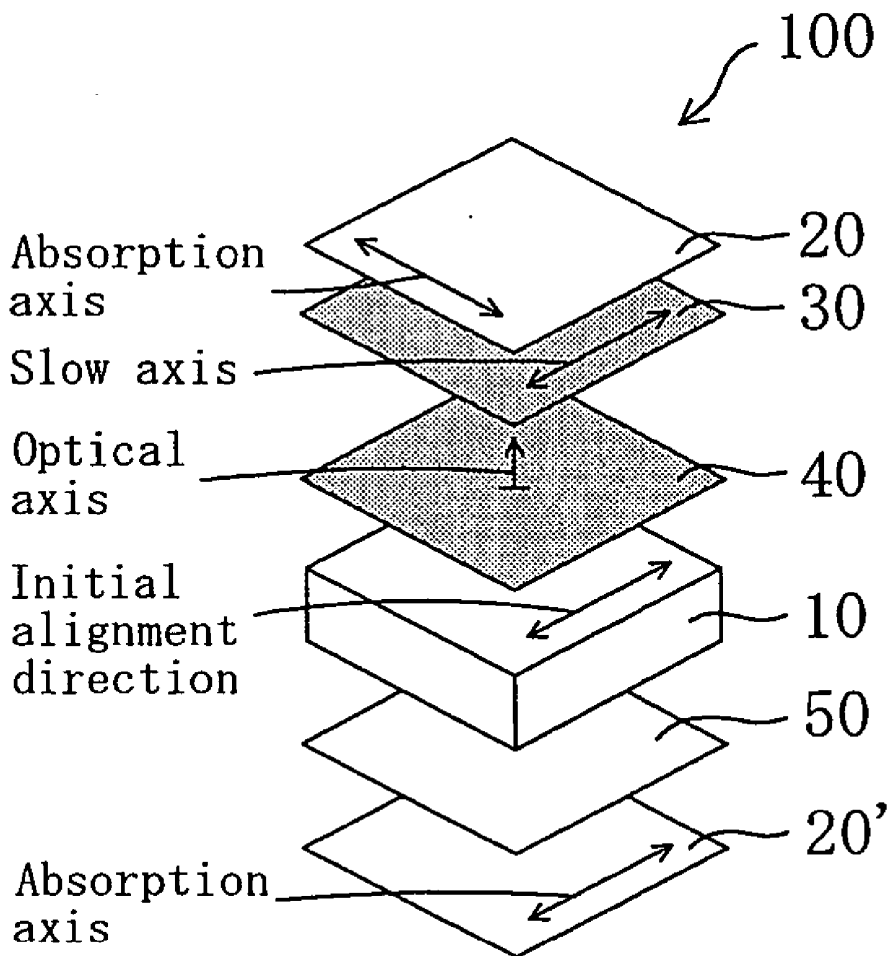

Fig. 1

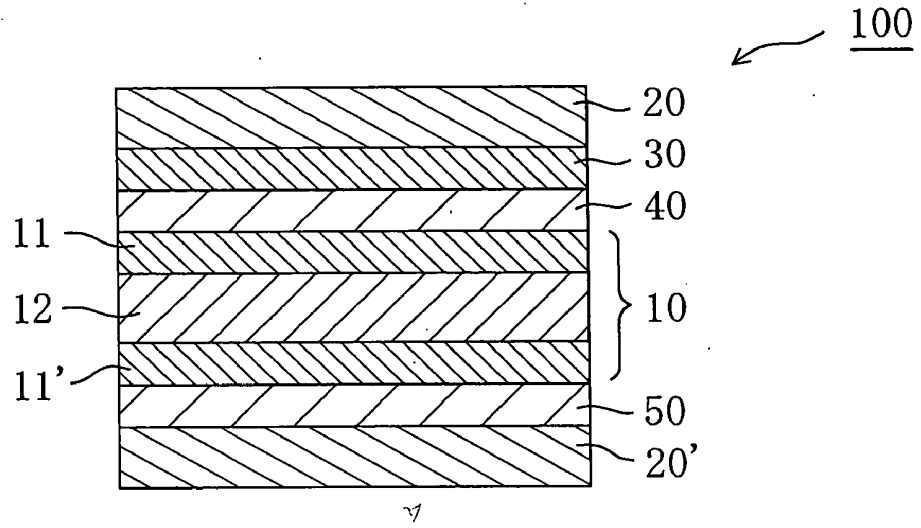

Fig. 2A

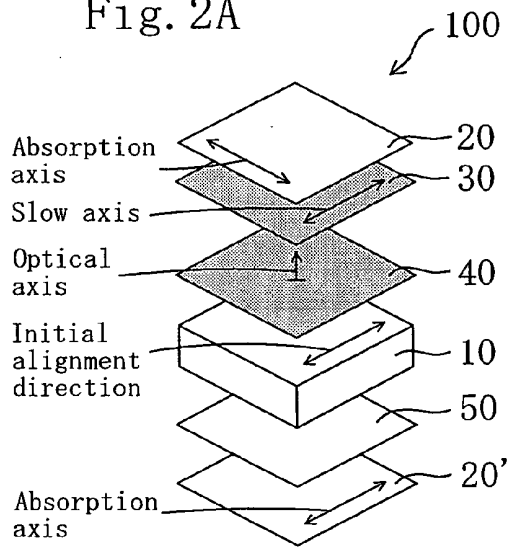

Fig. 2B

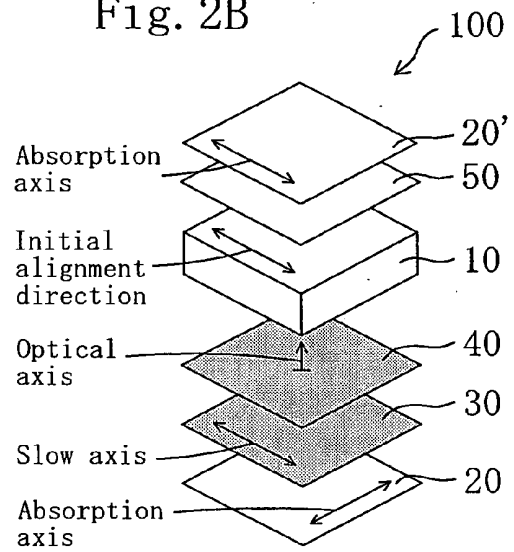
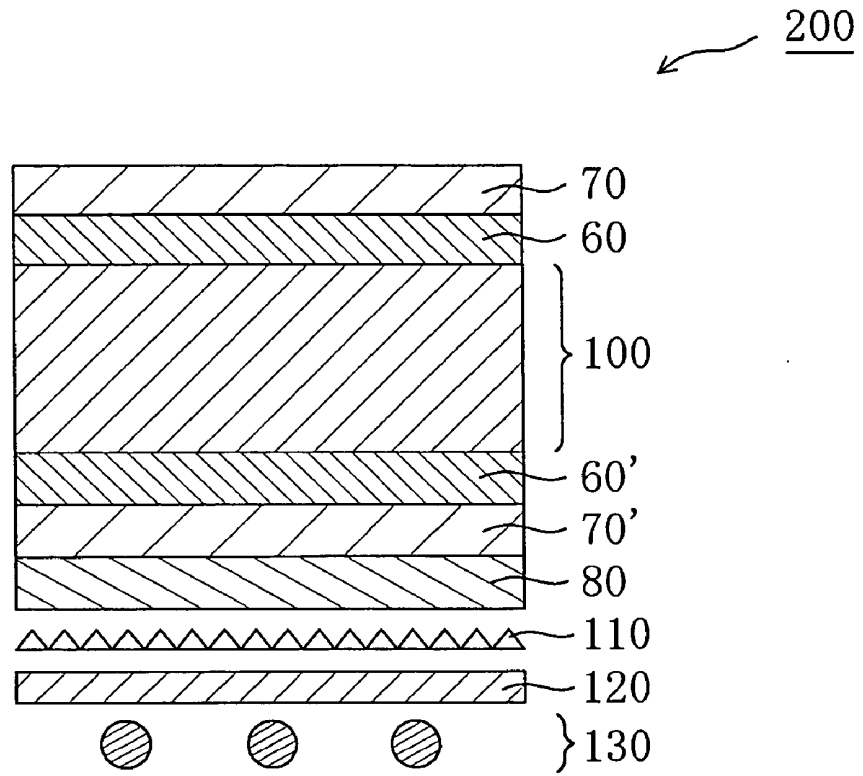

Fig.3



LIQUID CRYSTAL PANEL AND LIQUID CRYSTAL DISPLAY APPARATUS

[0001] This application claims priority under 35 U.S.C. Section 119 to Japanese Patent Application No. 2004-344053 filed on Nov. 29, 2004 and Japanese Patent Application No. 2005-244847 filed on Aug. 25, 2005, which are herein incorporated by reference.

FIELD OF THE INVENTION

[0002] The present invention relates to a liquid crystal panel having a liquid crystal cell, a polarizer, and an optical element. Further, the present invention relates to a liquid crystal television and a liquid crystal display apparatus both using the liquid crystal panel.

DESCRIPTION OF THE RELATED ART

[0003] A liquid crystal display apparatus provided with a liquid crystal cell of in-plane switching (IPS) mode involves control of light transmittance (white display) and light shielding (black display) through applying an electric field in a horizontal direction on liquid crystal molecules aligned in a substantially horizontal direction without application of the electric field to rotate the liquid crystal molecules by about 45°. A conventional liquid crystal display apparatus provided with a liquid crystal cell of IPS mode has problems in that: a contrast ratio is reduced when a screen is viewed from an oblique direction at an angle of 45° (azimuth angle of 45°, 135°, 225°, or 315°) with respect to an absorption axis of a polarizing plate; and a display color varying phenomenon (also referred to as color shift) increases depending on an angle the screen is viewed. Thus, there is disclosed a method of improving a color shift by arranging a plurality of retardation films on one side of a liquid crystal cell (see JP 11-133408, for example) However, such a technique improves the color shift, but does not sufficiently improve the contrast ratio in an oblique direction.

SUMMARY OF THE INVENTION

[0004] The present invention has been made in view of solving the above-mentioned problems, and an object of the present invention is therefore to provide a liquid crystal panel provided with a liquid crystal cell with improved contrast ratio in an oblique direction and improved color shift in an oblique direction.

[0005] The inventors of the present invention have conducted intensive studies for achieving the above-mentioned object, and have found that the object can be achieved by a liquid crystal panel and a liquid crystal display apparatus described below. Thus, the present invention has been completed.

[0006] A liquid crystal panel according to an embodiment of the present invention includes: a liquid crystal cell; a first polarizer arranged on one side of the liquid crystal cell; a second polarizer arranged on another side of the liquid crystal cell; a negative biaxial optical element and a positive C plate arranged between the liquid crystal cell and the first polarizer; and an isotropic optical element arranged between the liquid crystal cell and the second polarizer. Here, the negative biaxial optical element is arranged between the first polarizer and the positive C plate.

[0007] In one embodiment of the invention, the liquid crystal cell includes a liquid crystal layer containing homogeneously aligned liquid crystal molecules in the absence of an electric field.

[0008] In another embodiment of the invention, the liquid crystal layer has a refractive index profile of $n_x > n_y = n_z$.

[0009] In still another embodiment of the invention, the liquid crystal cell includes one of IPS mode, FFS mode, and FLC mode.

[0010] In still another embodiment of the invention, an initial alignment direction of the liquid crystal cell is substantially parallel to a direction of an absorption axis of the second polarizer.

[0011] In still another embodiment of the invention, the initial alignment direction of the liquid crystal cell is substantially parallel to a direction of an absorption axis of the polarizer arranged on a backlight side of the liquid crystal cell. Alternatively, the initial alignment direction of the liquid crystal cell is substantially perpendicular to a direction of an absorption axis of the polarizer arranged on a backlight side of the liquid crystal cell.

[0012] In still another embodiment of the invention, a slow axis of the negative biaxial optical element is substantially perpendicular to an absorption axis of the first polarizer.

[0013] In still another embodiment of the invention, the negative biaxial optical element has an in-plane retardation value ($Re[590]$) of 50 to 180 nm determined by using light of a wavelength of 590 nm at 23° C.

[0014] In still another embodiment of the invention, the negative biaxial optical element has a thickness direction retardation value ($Rth[590]$) of 110 to 250 nm determined by using light of a wavelength of 590 nm at 23° C.; and the thickness direction retardation value ($Rth[590]$) is larger than $Re[590]$.

[0015] In still another embodiment of the invention, the negative biaxial optical element has $Re[480]/Re[590]$ of 0.8 to 1.2.

[0016] In still another embodiment of the invention, the negative biaxial optical element includes a stretched film of a polymer film containing a cellulose ester as a main component.

[0017] In still another embodiment of the invention, the polymer film has an absolute value of photoelastic coefficient $C[590](m^2/N)$ of 2.0×10^{13} to 1.0×10^{10} .

[0018] In still another embodiment of the invention, the positive C plate has a thickness direction retardation value ($Rth[590]$) of -200 to -30 nm determined by using light of a wavelength of 590 nm at 23° C.

[0019] In still another embodiment of the invention, the positive C plate includes a single retardation film.

[0020] In still another embodiment of the invention, the positive C plate has a thickness of 0.1 to 3 μm .

[0021] In still another embodiment of the invention, the positive C plate includes one of a hardened layer and a cured layer of a homeotropically aligned liquid crystalline composition.

[0022] In still another embodiment of the invention, the isotropic optical element includes a polymer film containing as a main component at least one resin selected from the

group consisting of polynorbornene, a cellulose ester, an isobutylene/N-methylmaleimide copolymer, and an acrylonitrile/styrene copolymer.

[0023] According to another aspect of the invention, a liquid crystal television is provided. The liquid crystal television includes the above-described liquid crystal panel.

[0024] According to still another aspect of the invention, a liquid crystal display apparatus is provided. The liquid crystal display apparatus includes the above-described liquid crystal panel.

[0025] In the liquid crystal panel of the present invention, the negative biaxial optical element and the positive C plate are arranged between liquid crystal cell and the first polarizer arranged on one side of the liquid crystal cell. Further, the negative biaxial optical element is arranged between the first polarizer and the positive C plate, and the isotropic optical element is arranged between the liquid crystal cell and the second polarizer arranged on another side of the liquid crystal cell, to thereby increase a contrast ratio in an oblique direction and reduce a color shift in an oblique direction of the liquid crystal display apparatus.

BRIEF DESCRIPTION OF THE DRAWINGS

[0026] In the accompanying drawings:

[0027] **FIG. 1** is a schematic sectional view of a liquid crystal panel according to a preferred embodiment of the present invention;

[0028] **FIG. 2A** is a schematic perspective view of the liquid crystal panel of the present invention employing O-mode, and **FIG. 2B** is a schematic perspective view of the liquid crystal panel of the present invention employing E-mode; and

[0029] **FIG. 3** is a schematic sectional view of a liquid crystal display apparatus according to a preferred embodiment of the present invention.

DESCRIPTION OF THE PREFERRED EMBODIMENTS

A. Outline of Entire Liquid Crystal Panel

[0030] **FIG. 1** is a schematic sectional view of a liquid crystal panel according to a preferred embodiment of the present invention. **FIG. 2A** is a schematic perspective view of the liquid crystal panel employing O-mode, and **FIG. 2B** is a schematic perspective view of the liquid crystal panel employing E-mode. Note that, a ratio among length, width, and thickness of each member in **FIGS. 1, 2A, and 2B** is different from that of an actual member for clarity. In a case where a liquid crystal panel employs O-mode (**FIG. 2A**), for example, a liquid panel **100** is provided with: a liquid crystal cell **10**; a first polarizer **20** arranged on one side (viewer side in **FIG. 2A**) of the liquid crystal cell **10**; a second polarizer **20'** arranged on another side (backlight side in **FIG. 2A**) of the liquid crystal cell **10**; a negative biaxial optical element **30** and a positive C plate **40** arranged between the first polarizer **20** and the liquid crystal cell **10**; and an isotropic optical element **50** arranged between the second polarizer **20'** and the liquid crystal cell **10**. The negative biaxial optical element **30** is arranged between the first polarizer **20** and the positive C plate **40** such that a slow axis of the negative biaxial optical element **30** and an absorption axis of the first

polarizer **20** are perpendicular to each other. The positive C plate **40** is arranged between the negative biaxial optical element **30** and the liquid crystal cell **10**. The polarizers **20** and **20'** are arranged such that respective absorption axes are perpendicular to each other. In practical use, any appropriate protective layers (not shown) may be arranged on outer sides of the polarizers **20** and **20'**. In another embodiment of the present invention, other members (preferably an isotropic optical element) may be arranged between the members shown in **FIG. 1**.

[0031] The second polarizer **20'** (that is, the polarizer on a side having the isotropic optical element **50** arranged) is preferably arranged such that its absorption axis is substantially parallel to an initial alignment direction of the liquid crystal cell **10**. The first polarizer **20** is arranged such that its absorption axis is substantially perpendicular to the initial alignment direction of the liquid crystal cell **10**.

[0032] The liquid crystal panel of the present invention may be of so-called O-mode or so-called E-mode. The term "liquid crystal panel of O-mode" refers to a liquid crystal panel in which an absorption axis of a polarizer arranged on a backlight side of a liquid crystal cell and an initial alignment direction of the liquid crystal cell are parallel to each other. The term "liquid crystal panel of E-mode" refers to a liquid crystal panel in which an absorption axis of a polarizer arranged on a backlight side of a liquid crystal cell and an initial alignment direction of the liquid crystal cell are perpendicular to each other. In the liquid crystal panel of O-mode as shown in **FIG. 2A**, the first polarizer **20**, the negative biaxial optical element **30**, and the positive C plate **40** are preferably arranged on a viewer side of the liquid crystal cell **10**, and the isotropic optical element **50** and the second polarizer **20'** are preferably arranged on a backlight side of the liquid crystal cell **10**. In the liquid crystal panel of E-mode as shown in **FIG. 2B**, the first polarizer **20**, the negative biaxial optical element **30**, and the positive C plate **40** are preferably arranged on a backlight side of the liquid crystal cell **10**, and the isotropic optical element **50** and the second polarizer **20'** are preferably arranged on a viewer side of the liquid crystal cell **10**. In the present invention, a liquid crystal panel of O-mode as shown in **FIG. 2A** is preferred because an arrangement of O-mode can realize better optical compensation. To be specific, in the arrangement of O-mode, the negative biaxial optical element and the positive C plate are arranged on a far side from backlight and thus hardly receive adverse effects due to heat of backlight, to thereby reduce shift or unevenness in retardation values.

B. Liquid Crystal Cell

[0033] Referring to **FIG. 1**, the liquid crystal cell **10** used in the liquid crystal panel of the present invention is provided with: a pair of substrates **11** and **11'**; and a liquid crystal layer **12** as a display medium held between the substrates **11** and **11'**. One substrate (color filter substrate) **11** is provided with color filters and black matrix (both not shown). The other substrate (active matrix substrate) **11'** is provided with: a switching element (typically TFT, not shown) for controlling electrooptic properties of liquid crystals; a scanning line (not shown) for providing a gate signal to the switching element and a signal line (not shown) for providing a source signal thereto; and a pixel electrode and a counter electrode (both not shown). The color filters may be provided in the active matrix substrate **11'** as well. A

distance (cell gap) between the substrates **11** and **11'** is controlled by a spacer (not shown). An alignment film (not shown) formed of, for example, polyimide is provided on a side of each of the substrates **11** and **11'** in contact with the liquid crystal layer **12**.

[0034] The liquid crystal layer **12** preferably contains homogeneously aligned liquid crystal molecules in the absence of an electric field. The liquid crystal layer (eventually, the liquid crystal cell) generally exhibits a refractive index profile of $n_x > n_y = n_z$ (where, n_x , n_y , and n_z respectively represent refractive indices in the slow axis direction, fast axis direction, and thickness direction of the liquid crystal layer). In the specification of the present invention, $n_y = n_z$ includes not only a case where n_y and n_z are exactly equal, but also a case where n_y and n_z are substantially equal. Further, the phrase "initial alignment direction of the liquid crystal cell" refers to a direction providing a maximum in-plane refractive index of the liquid crystal layer by alignment of the liquid crystal molecules in the liquid crystal layer in the absence of an electric field. Typical examples of drive mode using the liquid crystal layer exhibiting such refractive index profile include: in-plane switching (IPS) mode; fringe field switching (FFS) mode; and ferroelectric liquid crystal (FLC) mode. Specific examples of liquid crystals used for those drive modes include nematic liquid crystals and smectic liquid crystals. For example, the nematic liquid crystals are used for the IPS mode and the FFS mode, and the smectic liquid crystals are used for the FLC mode.

[0035] In the IPS mode, homogeneously aligned liquid crystal molecules in the absence of an electric field respond in an electric field parallel to substrates (also referred to as a horizontal electric field) generated between a counter electrode and a pixel electrode each formed of metal, for example, by utilizing an electrically controlled birefringence (ECB) effect. To be specific, as described in "Monthly Display July" (p.83 to p.88, published by Techno Times Co., Ltd., 1997) or "Ekisho vol. 2, No. 4" (p. 303 to p. 316, published by Japanese Liquid Crystal Society, 1998), normally black mode provides completely black display in the absence of an electric field by: adjusting an alignment direction of the liquid crystal cell without application of an electric field, in a direction of an absorption axis of one polarizer; and arranging polarizing plates above and below the liquid crystal cell to be perpendicular to each other. Under application of an electric field, liquid crystal molecules rotate while remaining parallel to substrates, to thereby obtain a transmittance in accordance with a rotation angle. The IPS mode includes super in-plane switching (S-IPS) mode and advanced super in-plane switching (AS-IPS) mode each employing a V-shaped electrode, a zigzag electrode, or the like. Examples of a commercially available liquid crystal display apparatus of IPS mode include: 20-inch wide liquid crystal television "Wooo" (trade name, manufactured by Hitachi, Ltd.); 19-inch liquid crystal display "ProLite E481S-1" (trade name, manufactured by Iiyama Corporation); and 17-inch TFT liquid crystal display "FlexScan L565" (trade name, manufactured by Eizo Nanao Corporation).

[0036] In the FFS mode, homogeneously aligned liquid crystal molecules in the absence of an electric field respond in an electric field parallel to substrates (also referred to as a horizontal electric field) generated between a counter

electrode and a pixel electrode each formed of transparent conductor, for example, by utilizing an electrically controlled birefringence (ECB) effect. The horizontal electric field in the FFS mode is referred to as a fringe electric field, which can be generated by setting a distance between the counter electrode and the pixel electrode each formed of transparent conductor narrower than a cell gap. To be specific, as described in "Society for Information Display (SID) 2001 Digest" (p. 484 to p. 487) or JP 2002-031812 A, normally black mode provides completely black display in the absence of an electric field by: adjusting an alignment direction of the liquid crystal cell without application of an electric field, in a direction of an absorption axis of one polarizer; and arranging polarizing plates above and below the liquid crystal cell to be perpendicular to each other. Under application of an electric field, liquid crystal molecules rotate while remaining parallel to substrates, to thereby obtain a transmittance in accordance with a rotation angle. The FFS mode includes advanced fringe field switching (A-FFS) mode and ultra fringe field switching (U-FFS) mode each employing a V-shaped electrode, a zigzag electrode, or the like. An example of a commercially available liquid crystal display apparatus of FFS mode includes Tablet PC "M1400" (trade name, manufactured by Motion Computing, Inc.).

[0037] The FLC mode utilizes property of ferromagnetic chiral smectic liquid crystals encapsulated between electrode substrates each having a thickness of about 1 to 2 μm to exhibit two stable states of molecular alignment, for example. To be specific, the ferroelectric chiral smectic liquid crystal molecules rotate within a plane parallel to the substrates and respond due to application of a voltage. The FLC mode can provide black and white displays based on the same principle as that of the IPS mode or the FFS mode. The FLC mode has such a feature in that a response speed is high compared with those in other drive modes. In the specification of the present invention, the FLC mode includes: surface stabilized ferroelectric liquid crystal (SS-FLC) mode; antiferroelectric liquid crystal (AFLC) mode; polymer stabilized ferroelectric liquid crystal (PS-FLC) mode; and V-shaped switching ferroelectric liquid crystal (V-FLC) mode.

[0038] The homogeneously aligned liquid crystal molecules are obtained as a result of interaction between substrates subjected to alignment treatment and liquid crystal molecules, in which alignment vectors of the liquid crystal molecules are parallel to a substrate plane and uniformly aligned. In the specification of the present invention, homogenous alignment includes a case where the alignment vectors are slightly inclined with respect to the substrate plane, that is, a case where the liquid crystal molecules are pretilted. In a case where the liquid crystal molecules are pretilted, a pretilt angle is preferably 20° or less for maintaining a large contrast ratio and obtaining favorable display properties.

[0039] Any appropriate nematic liquid crystals may be employed as the nematic liquid crystals depending on the purpose. For example, the nematic liquid crystals may have positive dielectric anisotropy or negative dielectric anisotropy. A specific example of the nematic liquid crystals having positive dielectric anisotropy includes "ZLI-4535" (trade name, available from Merck Ltd., Japan). A specific example of the nematic liquid crystals having negative dielectric anisotropy includes "ZLI-2806" (trade name,

available from Merck Ltd., Japan). A difference between an ordinary index (no) and an extraordinary index (ne), that is, a birefringence (Δn_{LC}) can be appropriately selected in accordance with the response speed, transmittance, and the like of the liquid crystals. However, the birefringence is preferably 0.05 to 0.30, in general.

[0040] Any appropriate smectic liquid crystals may be employed as the smectic liquid crystals depending on the purpose. The smectic liquid crystals to be used preferably have an asymmetric carbon atom in a part of a molecular structure and exhibit ferroelectric property (also referred to as ferroelectric liquid crystals). Specific examples of the smectic liquid crystals exhibiting ferroelectric property include: p-decyloxybenzylidene-p'-amino-2-methylbutylcinnamate; p-hexyloxybenzylidene-p'-amino-2-chloropropylcinnamate; and 4-o-(2-methyl)butylresorcyldiene-4'-octylaniline. Examples of commercially available ferroelectric liquid crystals include: ZLI-5014-000 (trade name, capacitance of 2.88 nF, spontaneous polarization of -2.8 C/cm², available from Merck Ltd., Japan); ZLI-5014-100 (trade name, capacitance of 3.19 nF, spontaneous polarization of -20.0 C/cm², available from Merck Ltd., Japan); and FELIX-008 (trade name, capacitance of 2.26 nF, spontaneous polarization of -9.6 C/cm², available from Hoechst Aktiengesellschaft).

[0041] Any appropriate cell gap may be employed as the cell gap (distance between substrates) of the liquid crystal cell depending on the purpose. However, the cell gap is preferably 1.0 to 7.0 μ m. A cell gap within the above range can reduce response time and provide favorable display properties.

C. Polarizer

[0042] In the specification of the present invention, the term "polarizer" refers to a film capable of converting natural light or polarized light into appropriate polarized light. Any appropriate polarizer may be employed as a polarizer used in the present invention. Preferably, a polarizer capable of converting natural light or polarized light into linearly polarized light is used.

[0043] The polarizer may have any appropriate thickness. The thickness of the polarizer is typically 5 to 80 μ m, preferably 10 to 50 μ m, and more preferably 20 to 40 μ m. A thickness of the polarizer within the above ranges can provide excellent optical properties and mechanical strength.

[0044] A light transmittance (also referred to as single axis transmittance) of the polarizer is preferably 41% or more, and more preferably 43% or more measured by using light of a wavelength of 440 nm at 23° C. A theoretical upper limit of the single axis transmittance is 50%. A degree of polarization is preferably 99.8 to 100%, and more preferably 99.9 to 100%. A single axis transmittance and a degree of polarization within the above ranges can further increase a contrast ratio in a normal direction of a liquid crystal display apparatus employing the polarizer.

[0045] The single axis transmittance and the degree of polarization can be determined by using a spectrophotometer "DOT-3" (trade name, manufactured by Murakami Color Research Laboratory). The degree of polarization can be determined by: measuring a parallel light transmittance (H_0) and a perpendicular light transmittance (H_{90}) of the

polarizer; and using the following equation. Degree of polarization (%) = $\{(H_0 - H_{90}) / (H_0 + H_{90})\}^{1/2} \times 100$. The parallel light transmittance (H_0) refers to a transmittance of a parallel laminate polarizer produced by piling two identical polarizers such that respective absorption axes are parallel to each other. The perpendicular light transmittance (H_{90}) refers to a transmittance of a perpendicular laminate polarizer produced by piling two identical polarizers such that respective absorption axes are perpendicular to each other. The light transmittance refers to a Y value obtained through color correction by a two-degree field of view (C source) in accordance with JIS Z8701-1982.

[0046] Any appropriate polarizer may be employed as the polarizer used in the present invention depending on the purpose. Examples thereof include: a film prepared by adsorbing a dichromatic substance such as iodine or a dichromatic dye on a hydrophilic polymer film such as a polyvinyl alcohol-based film, a partially formalized polyvinyl alcohol-based film, or a partially saponified ethylene/vinyl acetate copolymer-based film and uniaxially stretching the film; and a polyene-based orientation film such as a dehydrated product of a polyvinyl alcohol-based film or a dechlorinated product of a polyvinyl chloride-based film. Of those, a polarizer prepared by adsorbing a dichromatic substance such as iodine on a polyvinyl alcohol-based film and uniaxially stretching the film is particularly preferred because of its high polarized dichromaticity.

[0047] The polarizer prepared by adsorbing iodine on a polyvinyl alcohol-based film and uniaxially stretching the film may be produced by, for example: immersing a polyvinyl alcohol-based film in an aqueous solution of iodine for coloring; and stretching the film to a 3 to 7 times length of the original length. The aqueous solution may contain boric acid, zinc sulfate, zinc chloride, or the like as required, or the polyvinyl alcohol-based film may be immersed in an aqueous solution of potassium iodide or the like. Further, the polyvinyl alcohol-based film may be immersed and washed in water before coloring as required.

[0048] Washing the polyvinyl alcohol-based film with water not only allows removal of contamination on a film surface or washing away of an antiblocking agent, but also provides an effect of preventing unevenness such as uneven coloring by swelling of the polyvinyl alcohol-based film. The stretching of the film may be performed after coloring of the film with iodine, performed during coloring of the film, or performed followed by coloring of the film with iodine. The stretching may be performed in an aqueous solution of boric acid or potassium iodide, or in a water bath.

[0049] In addition to the above-described polarizer, further examples of the polarizer to be used in the present invention include: a polarizer prepared by stretching a polymer film containing a dichromatic substance such as iodine or a dichromatic dye; an O-type polarizer of guest/host-type prepared by aligning in a specific direction a liquid crystalline composition containing a dichromatic substance and a liquid crystalline compound (U.S. Pat. No. 5,523,863); and an E-type polarizer prepared by aligning lyotropic liquid crystals in a specific direction (U.S. Pat. No. 6,049,428).

[0050] In the liquid crystal panel of the present invention, the polarizers arranged on both sides of the liquid crystal cell may be identical to or different from each other.

[0051] Referring to FIGS. 2A and 2B, any appropriate method may be employed as a method of arranging the first

polarizer **20** and the second polarizer **20'** depending on the purpose. Preferably, the first polarizer **20** and the second polarizer **20'** are each provided with an adhesive layer or a pressure sensitive adhesive layer (not shown) on a surface opposing the liquid crystal cell. Then, the first polarizer **20** is bonded to a surface of the negative biaxial optical element **30**, and the second polarizer **20'** is bonded to a surface of the isotropic optical element **50**. In this way, contrast of a liquid crystal display apparatus employing the polarizers can be increased.

[0052] A thickness of the adhesive layer or pressure sensitive adhesive layer may be appropriately determined in accordance with intended use, adhesive strength, and the like. The adhesive layer has a thickness of generally 0.1 to 50 μm , preferably 0.1 to 20 μm , and particularly preferably 0.1 to 10 μm . The pressure sensitive adhesive layer has a thickness of generally 1 to 100 μm , preferably 5 to 80 μm , and particularly preferably 10 to 50 μm .

[0053] Any appropriate adhesive or pressure sensitive adhesive may be employed for forming the adhesive layer or pressure sensitive adhesive layer in accordance with the kind of adherend. In particular, in a case where a polyvinyl alcohol-based film is used for the polarizer, an aqueous adhesive is preferably used as the adhesive. An adhesive containing a polyvinyl alcohol-based resin as a main component is more preferably used. A specific example thereof includes an adhesive "GOHSEFIMER Z200" (trade name, available from Nippon Synthetic Chemical Industry Co., Ltd.) containing as a main component modified polyvinyl alcohol having an acetoacetyl group. An acrylic pressure sensitive adhesive containing an acrylic polymer as a base polymer is preferably used as the pressure sensitive adhesive from viewpoints of excellent optical transparency, appropriate pressure sensitive adhesive properties such as wetting property, agglomeration property, and adhesiveness, and excellent weatherability and thermal resistance. A specific example thereof includes a double-face optical tape "SK-2057" (trade name, available from Soken Chemical & Engineering Co., Ltd.) containing an acrylic pressure sensitive adhesive as a pressure sensitive adhesive layer.

[0054] The first polarizer **20** is preferably arranged such that its absorption axis is substantially perpendicular to an absorption axis of the opposing second polarizer **20'**. In the specification of the present invention, the phrase "substantially perpendicular" includes a case where the absorption axis of the first polarizer **20** and the absorption axis of the second polarizer **20'** form an angle of $90^\circ \pm 2.0^\circ$, preferably $90^\circ \pm 1.0^\circ$, and more preferably $90^\circ \pm 0.5^\circ$. An angle greatly departing from the above ranges tends to cause reduction in contrast of a liquid crystal display apparatus employing the first polarizer **20** and the second polarizer **20'**.

D. Negative Biaxial Optical Element

[0055] In the specification of the present invention, the term "negative biaxial optical element" refers to an optical element having a refractive index profile of $n_x > n_y > n_z$ (where, n_x and n_y respectively represent main in-plane refractive indices in a slow axis direction and a fast axis direction, and n_z represents a thickness direction refractive index). An optical element satisfying the refractive index profile of $n_x > n_y > n_z$ may be reworded as an optical element satisfying an expression of $R_{th}[590] > Re[590]$. $Re[590]$ and $R_{th}[590]$ will be described below.

[0056] Referring to FIGS. 1, 2A, and 2B, the negative biaxial optical element **30** is arranged between the first polarizer **20** and the positive C plate **40**.

D-1. Optical Properties of Negative Biaxial Optical Element

[0057] In the specification of the present invention, $Re[590]$ refers to an in-plane retardation value determined by using light of a wavelength of 590 nm at 23° C. $Re[590]$ can be determined from an equation $Re[590] = (n_x - n_y) \times d$ (where, n_x and n_y respectively represent refractive indices of an optical element (or retardation film) in a slow axis direction and a fast axis direction at a wavelength of 590 nm, and d (nm) represents a thickness of the optical element (or retardation film)). Note that, the slow axis refers to a direction providing a maximum in-plane refractive index.

[0058] The negative biaxial optical element used in the present invention has $Re[590]$ of preferably 50 to 180 nm, more preferably 60 to 160 nm, particularly preferably 70 to 150 nm, and most preferably 80 to 130 nm. $Re[590]$ within the above ranges can increase a contrast ratio in an oblique direction of the liquid crystal display apparatus.

[0059] In the specification of the present invention, $R_{th}[590]$ refers to a film thickness direction retardation value determined by using light of a wavelength of 590 nm at 23° C. $R_{th}[590]$ can be determined from an equation $R_{th}[590] = (n_x - n_z) \times d$ (where, n_x and n_y respectively represent refractive indices of an optical element (or retardation film) in a slow axis direction and a fast axis direction at a wavelength of 590 nm, and d (nm) represents a thickness of the optical element (or retardation film)). Note that, the slow axis refers to a direction providing a maximum in-plane refractive index.

[0060] The negative biaxial optical element used in the present invention has $R_{th}[590]$ of preferably 110 to 250 nm, more preferably 120 to 230 nm, particularly preferably 130 to 200 nm, and most preferably 140 to 180 nm as long as a relationship $R_{th}[590] > Re[590]$ is satisfied. $R_{th}[590]$ within the above ranges can increase a contrast ratio in an oblique direction of the liquid crystal display apparatus.

[0061] $Re[590]$ and $R_{th}[590]$ maybe determined by using "KOBRA-21ADH" (trade name, manufactured by Oji Scientific Instruments). Refractive indices n_x , n_y , and n_z can be determined by: using an in-plane retardation value (Re) determined at a wavelength of 590 nm at 23° C., a retardation value (R_{40}) determined by inclining a slow axis by 40° as a tilt angle, a thickness (d) of a retardation film, and an average refractive index (n_0) of the retardation film; and using the following equations (i) to (iii) for computational numerical calculation. Then, R_{th} can be calculated from the following equation (iv). Here, Φ and n_y' are represented by the following respective equations (v) and (vi).

$$Re = (n_x - n_y) \times d \quad (i)$$

$$R_{40} = (n_x - n_y') \times d / \cos(\Phi) \quad (ii)$$

$$(n_x + n_y + n_z) / 3 = n_0 \quad (iii)$$

$$R_{th} = (n_x - n_z) \times d \quad (iv)$$

$$\Phi = \sin^{-1}[\sin(40^\circ) / n_0] \quad (v)$$

$$n_y' = n_y \times n_z [n_y^2 \times \sin^2(\Phi) + n_z^2 \times \cos^2(\Phi)]^{1/2} \quad (vi)$$

[0062] In general, retardation values may vary depending on wavelength. This phenomenon is referred to as wavelength dispersion property of retardation values. In the

specification of the present invention, the wavelength dispersion property can be determined as a ratio $Re[480]/Re[590]$ of in-plane retardation values determined by using light of a wavelength of 480 nm and light of a wavelength of 590 nm at 23° C.

[0063] The negative biaxial optical element has $Re[480]/Re[590]$ of preferably 0.8 to 1.2, more preferably 0.8 to 1.1, and particularly preferably 0.8 to 1.0. Smaller $Re[480]/Re[590]$ within the above ranges provides uniform retardation values in a wide visible light region. As a result, in a liquid crystal display apparatus employing the negative biaxial optical element, light of specific wavelength hardly leaks and a color shift in an oblique direction of the liquid crystal display apparatus can be further reduced.

D-2. Means for Arranging Negative Biaxial Optical Element

[0064] Referring to FIGS. 1, 2A, and 2B, the negative biaxial optical element 30 is arranged between the first polarizer 20 and the positive C plate 40. Any appropriate method may be employed as a method of arranging the negative biaxial optical element 30 between the first polarizer 20 and the positive C plate 40 depending on the purpose. The negative biaxial optical element 30 is preferably bonded to the first polarizer 20 and the positive C plate 40 by providing an adhesive layer or pressure sensitive adhesive layer (not shown) on each side of the negative biaxial optical element 30. In this way, contrast of a liquid crystal display apparatus employing the negative biaxial optical element 30 can be increased.

[0065] A thickness of the adhesive layer or pressure sensitive adhesive layer may be appropriately determined in accordance with intended use, adhesive strength, and the like. The adhesive layer has an appropriate thickness of generally 0.1 to 50 μm , preferably 0.1 to 20 μm , and particularly preferably 0.1 to 10 μm . The pressure sensitive adhesive layer has an appropriate thickness of generally 1 to 100 μm , preferably 5 to 80 μm , and particularly preferably 10 to 50 μm .

[0066] Any appropriate adhesive or pressure sensitive adhesive may be employed for forming the adhesive layer or pressure sensitive adhesive layer. Examples thereof include those each containing as a base polymer a polymer such as an acrylic polymer, a silicone-based polymer, polyester, polyurethane, polyamide, polyvinyl ether, a vinyl acetate/vinyl chloride copolymer, modified polyolefin, an epoxy-based polymer, a fluorine-based polymer, or a rubber-based polymer (such as a natural rubber-based polymer or a synthetic rubber-based polymer), which can be appropriately selected and used. In particular, in a case where one adherend is a polarizer prepared by adsorbing a dichromatic substance such as iodine on a polyvinyl alcohol-based film and uniaxially stretching the film, an aqueous adhesive is preferably used as the adhesive. An adhesive containing a polyvinyl alcohol-based resin as a main component is particularly preferably used. A specific example thereof includes an adhesive "GOHSEFIMER Z2000" (trade name, available from Nippon Synthetic Chemical Industry Co., Ltd.) containing as a main component modified polyvinyl alcohol having an acetoacetyl group. An acrylic pressure sensitive adhesive containing an acrylic polymer as a base polymer is preferably used as the pressure sensitive adhesive from the viewpoints of excellent optical transparency, appropriate pressure sensitive adhesive properties such as

wetting property, agglomeration property, and adhesiveness, and excellent weatherability and thermal resistance. A specific example thereof includes a double-face optical tape "SK-2057" (tradename, available from Soken Chemical & Engineering Co., Ltd.) containing an acrylic pressure sensitive adhesive as a pressure sensitive adhesive layer.

[0067] The negative biaxial optical element 30 is preferably arranged such that its slow axis is substantially perpendicular to an absorption axis of the adjacent first polarizer 20. In the specification of the present invention, the phrase "substantially perpendicular" includes a case where the slow axis of the negative biaxial optical element 30 and the absorption axis of the first polarizer 20 form an angle of $90^\circ \pm 2.0^\circ$, preferably $90^\circ \pm 1.0^\circ$, and more preferably $90^\circ \pm 0.5^\circ$. An angle greatly departing from the above ranges tends to cause reduction in contrast of a liquid crystal display apparatus employing the negative biaxial optical element 30.

D-3. Structure of Negative Biaxial Optical Element

[0068] A structure (laminate structure) of the negative biaxial optical element is not particularly limited as long as the optical properties as described in the above section D-1 are satisfied. To be specific, the negative biaxial optical element maybe a single retardation film, or a laminate of two or more retardation films. The negative biaxial optical element is preferably a single retardation film for reducing shift or unevenness in retardation values due to shrinkage stress of the polarizer or heat of backlight and for reducing a thickness of a liquid crystal panel. The negative biaxial optical element as a laminate may include an adhesive layer, a pressure sensitive adhesive layer, or the like for attaching two or more retardation films. In a case where the negative biaxial optical element as a laminate includes two or more retardation films, the retardation films may be identical to or different from each other. Details of the retardation film will be described below.

[0069] $Re[590]$ of a retardation film used for the negative biaxial optical element can be appropriately selected in accordance with the number of retardation films to be used. For example, in a case where the negative biaxial optical element is formed of a single retardation film, $Re[590]$ of the retardation film is preferably equal to $Re[590]$ of the negative biaxial optical element. Thus, retardation of a pressure sensitive adhesive layer, an adhesive layer, or the like used for laminating the negative biaxial optical element on the polarizer or the positive C plate is preferably as small as possible. Further, in a case where the negative biaxial optical element is a laminate including two or more retardation films, for example, the laminate is preferably designed such that total $Re[590]$ of the retardation films is equal to $Re[590]$ of the negative biaxial optical element. To be specific, a negative biaxial optical element having $Re[590]$ of 100 nm can be obtained by laminating two retardation films each having $Re[590]$ of 50 nm such that respective slow axes are perpendicular to each other. The present specification describes the cases each employing two or less retardation films for simplicity, but the present invention may obviously be applied to a laminate including three or more retardation films.

[0070] A total thickness of the negative biaxial optical element is preferably 10 to 500 μm , more preferably 20 to 400 μm , and most preferably 30 to 300 μm . The negative

biaxial optical element having a thickness within the above ranges can provide a liquid crystal display apparatus with excellent optical uniformity.

D-4. Retardation Film Used for Negative Biaxial Optical Element

[0071] The retardation film used for the negative biaxial optical element is preferably a retardation film having excellent transparency, mechanical strength, thermal stability, water barrier property, and the like, and hardly causing optical unevenness due to distortion. A stretched film of a polymer film containing a thermoplastic resin as a main component is preferably used as the retardation film. In the specification of the present invention, the term "stretched film" refers to a plastic film having enhanced alignment of molecules in a specific direction obtained by: applying tension to an unstretched film at an appropriate temperature; or applying additional tension to a film stretched in advance.

[0072] The retardation film has a light transmittance of preferably 80% or more, more preferably 85% or more, and particularly preferably 90% or more measured by using light of a wavelength of 590 nm at 23° C. A theoretical upper limit of the light transmittance is 100%, and a feasible upper limit thereof may be 94%. The negative biaxial optical element preferably has a similar light transmittance as a whole.

[0073] An absolute value of photoelastic coefficient $C[590]$ (m^2/N) of the retardation film is preferably 2.0×10^{-13} to 1.0×10^{-10} , more preferably 1.0×10^{-12} to 1.0×10^{-10} , and particularly preferably 1.0×10^{-12} to 3.0×10^{-11} . An absolute value of photoelastic coefficient within the above ranges can provide a liquid crystal display apparatus with excellent display uniformity.

[0074] The retardation film may have any appropriate thickness depending on the purpose or the laminate structure of the negative biaxial optical element. In a case where the negative biaxial optical element is formed of a single retardation film, the retardation film has a thickness equal to a total thickness of the negative biaxial optical element. Further, in a case where the negative biaxial optical element has a laminate structure, a thickness of each retardation film may be set such that a total thickness of the retardation films is equal to a preferred total thickness of the negative biaxial optical element. The retardation films may each have an identical thickness or a different thickness. To be specific, the thickness of the retardation film is preferably 10 to 250 μm , more preferably 20 to 200 μm , and particularly preferably 30 to 150 μm . A thickness of the retardation film within the above ranges can provide a retardation film with excellent mechanical strength and display uniformity.

[0075] Any appropriate forming method may be employed as a method of obtaining the polymer film containing a thermoplastic resin as a main component. Any appropriate method may be selected from compression molding, transfer molding, injection molding, extrusion, blow molding, powder molding, FRP molding, solvent casting, and the like. Of those, extrusion and solvent casting are preferred because a highly smooth retardation film with favorable optical uniformity can be obtained. To be specific, the extrusion involves: melting a resin composition containing a thermoplastic resin as a main component, a plasticizer, an additive, and the like under heating; extruding the melted resin

composition into a thin film on a surface of a casting roller by using a T-die or the like; and cooling the whole to produce a film. Further, the solvent casting involves: defoaming a rich solution (dope) prepared by dissolving in a solvent a resin composition containing a thermoplastic resin as a main component, a plasticizer, an additive, and the like; uniformly casting the defoamed solution into a thin film on a surface of an endless stainless steel belt or rotating drum; and evaporating the solvent to produce a film. Forming conditions may be appropriately selected in accordance with the composition or kind of the resin to be used, the forming method, and the like.

[0076] Examples of a material forming the thermoplastic resin include: general purpose plastics such as polyethylene, polypropylene, polynorbornene, polyvinyl chloride, a cellulose ester, polystyrene, an ABS resin, an AS resin, polymethylmethacrylate, polyvinyl acetate, and polyvinylidene chloride; general purpose engineering plastics such as polyamide, polyacetal, polycarbonate, modified polyphenylene ether, polybutylene terephthalate, and polyethylene terephthalate; and super engineering plastics such as polyphenylene sulfide, polysulfone, polyethersulfone, polyetheretherketone, polyarylate, a liquid crystal polymer, polyamideimide, polyimide, and polytetrafluoroethylene. The thermoplastic resin may be used after appropriate polymer modification. Examples of the polymer modification include copolymerization, branching, crosslinking, and modifications in molecular terminals and stereo regularity. Two or more kinds of thermoplastic resins may be mixed and used.

[0077] The polymer film containing a thermoplastic resin as a main component may further contain any appropriate additive as required. Specific examples of the additive include a plasticizer, a thermal stabilizer, a light stabilizer, a lubricant, an antioxidant, a UV absorber, a flame retardant, a colorant, an antistatic agent, a compatibilizing agent, a crosslinking agent, and a thickener. The kind and amount of the additive to be used may be appropriately set depending on the purpose. A use amount of the additive is generally 0.1 to 10 or less (weight ratio) with respect to a total solid content in the polymer film as 100.

[0078] The retardation film used for the negative biaxial optical element of the present invention is preferably a stretched film of a polymer film containing a cellulose ester as a main component because of its excellent transparency, mechanical strength, thermal stability, and water barrier property, developability of retardation values, easy control of retardation values, adhesiveness to a polarizer, and the like.

[0079] Any appropriate cellulose ester may be employed as the cellulose ester. Specific examples of the cellulose ester include organic acid esters such as cellulose acetate, cellulose propionate, and cellulose butyrate. The cellulose ester may be a mixed organic acid ester in which hydroxyl groups of cellulose are substituted partly by an acetyl group and partly by a propionyl group, for example. The cellulose ester is produced, for example, through a method described in paragraphs [0040] and [0041] of JP 2001-188128 A.

[0080] The cellulose ester has a weight average molecular weight (M_w) of preferably 30,000 to 500,000, more preferably 50,000 to 400,000, and particularly preferably 80,000 to 300,000 determined through gel permeation chromatog-

raphy (GPC) by using a tetrahydrofuran solvent. A weight average molecular weight of a cellulose ester within the above ranges can provide a polymer film with excellent mechanical strength, solubility, forming property, and casting workability.

[0081] Of the cellulose esters, a cellulose ester containing a repeating unit represented by the following general formula (1) is preferably used as the material forming the retardation film used for the negative biaxial optical element for excellent wavelength dispersion property of retardation values and easily developing retardation values.

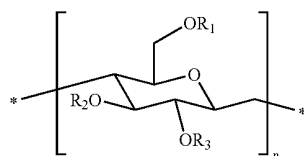

In the formula (1), R1 to R3 each represent an acyl group and n represents an integer of 1 or more. More preferably, R1 to R3 each independently represent an acetyl group or a propionyl group.

[0082] In the specification of the present invention, a degree of acetyl substitution (or degree of propionyl substitution) refers to the number of hydroxyl groups, which are bonded to carbon atoms at 2, 3, and 6 positions in a cellulose main chain, substituted by acetyl groups (or propionyl groups). The acetyl groups (or propionyl groups) may unevenly substitute any carbon atoms at 2, 3, and 6 positions in a cellulose main chain, or may evenly substitute the carbon atoms at 2, 3, and 6 positions. The degree of acetyl substitution may be determined in accordance with ASTM-D817-91 (Standard Test Methods of Testing Cellulose Acetate Propionate and Cellulose Acetate Butyrate). The degree of propionyl substitution may be determined in accordance with ASTM-D817-96 (Standard Test Methods of Testing Cellulose Acetate Propionate and Cellulose Acetate Butyrate).

[0083] In a case where the cellulose ester contains an acetyl group, the degree of acetyl substitution is preferably 1.5 to 3.0, more preferably 2.0 to 3.0, and particularly preferably 2.4 to 2.9. In a case where the cellulose ester contains a propionyl group, the degree of propionyl substitution is preferably 0.5 to 3.0, more preferably 0.5 to 2.0, and particularly preferably 0.5 to 1.5. In a case where the cellulose ester is a mixed organic acid ester in which hydroxyl groups of cellulose are substituted partly by an acetyl group and partly by a propionyl group, a total of degree of acetyl substitution and degree of propionyl substitution is preferably 1.5 to 3.0, more preferably 2.0 to 3.0, and particularly preferably 2.4 to 2.9. In this case, the degree of acetyl substitution is preferably 1.0 to 2.8, and the degree of propionyl substitution is preferably 0.2 to 2.0. More preferably, the degree of acetyl substitution is preferably 1.0 to 2.5, and the degree of propionyl substitution is preferably 0.5 to 2.0.

[0084] Any appropriate stretching method may be employed as a method of forming a stretched film of a

polymer film containing a thermoplastic resin as a main component. Specific examples of the stretching method include: a longitudinal uniaxial stretching method; a transverse uniaxial stretching method; a longitudinal and transverse simultaneous biaxial stretching method; and a longitudinal and transverse sequential biaxial stretching method. Any appropriate stretching machine such as a roll stretching machine, a tenter stretching machine, or a biaxial stretching machine may be used as stretching means. In a case where heat stretching is performed, a stretching temperature may be continuously changed or may be changed in steps. The stretching may be performed in two or more steps. A longitudinal uniaxial stretching method or a transverse uniaxial stretching method is preferably used because a retardation film having small variation in slow axes in a film width direction may be obtained. The longitudinal uniaxial stretching method is appropriately used for enhancing uniaxial property of molecules (alignment direction of molecules is easily aligned in a specific direction) and has such a feature in that large retardation values can be obtained even with a material hardly causing retardation values. The transverse uniaxial stretching method allows roller production of a laminate having a retardation film and a polarizer attached, in which a slow axis of the retardation film and an absorption axis of the polarizer are perpendicular to each other, and has such a feature in that productivity may be significantly enhanced.

[0085] A temperature inside a stretching oven (also referred to as stretching temperature) during stretching of the polymer film is preferably equal to or higher than a glass transition temperature (T_g) of the polymer film because retardation values easily even out in a width direction and the film hardly crystallizes (becomes clouded). The stretching temperature is preferably $T_g+1^\circ\text{C}$. to $T_g+30^\circ\text{C}$. More specifically, the stretching temperature is typically 110 to 200°C ., and more preferably 120 to 170°C . The glass transition temperature can be determined through a method in accordance with JISK7121-1987 by differential scanning calorimetry (DSC).

[0086] A specific method of controlling the temperature inside the stretching oven is not particularly limited, and may be appropriately selected from heating methods or temperature control methods using: an air-circulating thermostatic oven in which hot air or cool air circulates; a heater using microwaves, far infrared rays, or the like; a heated roller for temperature adjustment; a heat pipe roller; and a heated metal belt.

[0087] A stretch ratio during stretching of the polymer film is not particularly limited and may be appropriately determined in accordance with the composition of the polymer film, the kind of a volatile component or the like, the residual amount of the volatile component or the like, designed retardation values, and the like. To be specific, the stretch ratio is preferably 1.05 times to 2.00 times. A delivery speed during stretching is not particularly limited, but is preferably 0.5 to 20 m/min in consideration of the machine accuracy, stability, and the like of the stretching machine.

[0088] In addition to the polymer films described above, a commercially available optical film as it is may be used as the retardation film used for the negative biaxial optical element. A commercially available optical film may be subjected to fabrication such as stretching treatment and/or

relaxation treatment before use. Specific examples of a commercially available polynorbornene film include: "ZEONEX series" (480, 480R, etc., tradename, available from Zeon Corporation); "ZEONOR series" (ZF14, ZF16, etc., trade name, available from Zeon Corporation); and "ARTON series" (ARTON G, ARTON F, etc., trade name, available from JSR Corporation). Specific examples of a commercially available polycarbonate film include: "Pureace series" (tradename, available from Teijin Ltd.); "Elmech series" (R140, R435, etc., trade name, available from Kaneka Corporation); and "Illuminex series" (trade name, available from GE Plastics Japan, Ltd.).

E. Positive C Plate

[0089] In the specification of the present invention, the positive C plate refers to a positive uniaxial retardation optical element satisfying a refractive index profile of $n_z > n_x = n_y$ (where, n_x and n_y respectively represent main in-plane refractive indices in a slow axis direction and a fast axis direction, and n_z represents a thickness direction refractive index). The positive uniaxial retardation optical element ideally has an optical axis in a normal direction of the film. In the specification of the present invention, $n_x = n_y$ includes not only a case where n_x and n_y are exactly equal, but also a case where n_x and n_y are substantially equal. The phrase "case where n_x and n_y are substantially equal" as used herein includes a case where an in-plane retardation value (Re[590]) is 10 nm or less.

[0090] Referring to FIGS. 1, 2A, and 2B, the positive C plate 40 is arranged between the negative biaxial optical element 30 and the liquid crystal cell 10.

E-1. Optical Properties of Positive C Plate

[0091] The positive C plate used in the present invention has Re [590] of preferably 0 to 5 nm, and more preferably 0 to 2 nm. Re[590] within the above ranges can increase a contrast ratio in an oblique direction of the liquid crystal display apparatus.

[0092] The positive C plate used in the present invention has Rth[590] of preferably -200 to -30 nm, more preferably -180 to -40 nm, particularly preferably -150 to -50 nm, and most preferably -130 to -70 nm. Rth[590] within the above ranges can increase a contrast ratio in an oblique direction of the liquid crystal display apparatus.

E-2. Means for Arranging Positive C Plate

[0093] Any appropriate method may be employed as a method of arranging the positive C plate 40 between the negative biaxial optical element 30 and the liquid crystal cell 10 depending on the purpose. The positive C plate 40 is preferably bonded to the negative biaxial optical element 30 and the liquid crystal cell 10 by providing an adhesive layer or pressure sensitive adhesive layer (not shown) on each side of the positive C plate 40. In this way, contrast of a liquid crystal display apparatus employing the positive C plate 40 can be increased.

[0094] A thickness of the adhesive layer or pressure sensitive adhesive layer may be appropriately determined in accordance with intended use, adhesive strength, and the like. The adhesive layer has a thickness of generally 0.1 to 50 μm , preferably 0.1 to 20 μm , and particularly preferably 0.1 to 10 μm . The pressure sensitive adhesive layer has a

thickness of generally 1 to 100 μm , preferably 5 to 80 μm , and particularly preferably 10 to 50 μm .

[0095] Any appropriate adhesive or pressure sensitive adhesive may be employed for forming the adhesive layer or pressure sensitive adhesive layer. Examples thereof include those each containing as a base polymer a polymer such as an acrylic polymer, a silicone-based polymer, polyester, polyurethane, polyamide, polyvinyl ether, a vinyl acetate/vinyl chloride copolymer, modified polyolefin, an epoxy-based polymer, a fluorine-based polymer, or a rubber-based polymer (such as a natural rubber-based polymer or a synthetic rubber-based polymer), which can be appropriately selected and used. In particular, in a case where one adherend is a substrate (typically, glass substrate) used for the liquid crystal cell, a pressure sensitive adhesive is preferably used because when axis shift occurs during attaching of the polarizer, the polarizer may be peeled off (also referred to as reworked) for reusing the liquid crystal cell. An acrylic pressure sensitive adhesive containing an acrylic polymer as a base polymer is preferably used as a pressure sensitive adhesive used for attaching the positive C plate 40 to the surface of the liquid crystal cell 10 from the viewpoints of excellent optical transparency, appropriate pressure sensitive adhesive properties such as wetting property, agglomeration property, and adhesiveness, and excellent weatherability and thermal resistance. A specific example thereof includes a double-face optical tape "SK-2057" (trade name, available from Soken Chemical & Engineering Co., Ltd.) containing an acrylic pressure sensitive adhesive as a pressure sensitive adhesive layer.

[0096] In a case where n_x and n_y of the positive C plate 40 are exactly equal, the positive C plate 40 exhibits no in-plane birefringence and its slow axis is not detected. Thus, the positive C plate 40 may be arranged independently from the absorption axis of the first polarizer 20, the slow axis of the negative biaxial optical element 30, and an alignment direction of liquid crystal molecules in the liquid crystal cell 10. In a case where n_x and n_y of the positive C plate 40 are substantially equal but are slightly different, its slow axis may be detected. In this case, the positive C plate 40 is preferably arranged such that its slow axis is substantially parallel or perpendicular to the absorption axis of the first polarizer 20. In the specification of the present invention, the phrase "substantially parallel" includes a case where the slow axis of the positive C plate 40 and the absorption axis of the first polarizer 20 form an angle of $0^\circ \pm 2.0^\circ$, preferably $0^\circ \pm 1.0^\circ$, and more preferably $0^\circ \pm 0.5^\circ$. The phrase "substantially perpendicular" includes a case where the slow axis of the positive C plate 40 and the absorption axis of the first polarizer 20 form an angle of $90^\circ \pm 2.0^\circ$, preferably $90^\circ \pm 1.0^\circ$, and more preferably $90^\circ \pm 0.5^\circ$. An angle greatly departing from the above ranges tends to cause reduction in contrast of a liquid crystal display apparatus employing the positive C plate 40.

E-3. Structure of Positive C Plate

[0097] A structure (laminated structure) of the positive C plate is not particularly limited as long as the optical properties as described in the above section E-1 are satisfied. To be specific, the positive C plate may be a single retardation film, or a laminate of two or more retardation films. The positive C plate is preferably a single retardation film for reducing shift or unevenness in retardation values due to

shrinkage stress of the polarizer or heat of backlight and for reducing a thickness of a liquid crystal panel. The positive C plate as a laminate may include an adhesive layer, a pressure sensitive adhesive layer, or the like for attaching two or more retardation films. In a case where the positive C plate as a laminate includes two or more retardation films, the retardation films may be identical to or different from each other. Details of the retardation film will be described below.

[0098] Rth[590] of a retardation film used for the positive C plate can be appropriately selected in accordance with the number of retardation films to be used. For example, in a case where the positive C plate is formed of a single retardation film, Rth[590] of the retardation film is preferably equal to Rth[590] of the positive C plate. Thus, retardation of a pressure sensitive adhesive layer, an adhesive layer, or the like used for laminating the positive C plate on the negative biaxial optical element or the liquid crystal cell is preferably as small as possible. Further, in a case where the positive C plate is a laminate including two or more retardation films, for example, the laminate is preferably designed such that total Rth[590] of the retardation films is equal to Rth[590] of the positive C plate. To be specific, a positive C plate having Rth[590] of -100 nm can be obtained by laminating two retardation films each having Rth[590] of -50 nm, or by laminating a retardation film having Rth[590] of $+50$ nm and a retardation film having Rth[590] of -150 nm, for example. In such cases, the two retardation films are laminated such that respective slow axes are perpendicular to each other, which can reduce an in-plane retardation value of the positive C plate. The present specification describes the cases each employing two or less retardation films for simplicity, but the present invention may obviously be applied to a laminate including three or more retardation films.

[0099] In a case where the positive C plate is formed of a single retardation film, a total thickness of the positive C plate is preferably 0.1 to 3 μm , more preferably 0.3 to 2 μm , and particularly preferably 0.5 to 2 μm . In a case where the positive C plate is formed of two or more retardation films, a total thickness of the positive C plate is preferably 1 to 200 μm , more preferably 1 to 150 μm , and particularly preferably 1 to 120 μm .

E-4. Retardation Film Used for Positive C Plate

[0100] The retardation film used for the positive C plate is preferably a retardation film having excellent transparency, mechanical strength, thermal stability, water barrier property, and the like, and hardly causing optical unevenness due to distortion. The retardation film is preferably a hardened layer or cured layer of a homeotropically aligned liquid crystalline composition.

[0101] In the specification of the present invention, the term "homeotropically aligned" refers to a state of a liquid crystal compound in a liquid crystalline composition uniformly aligned parallel to a normal direction of a film. The term "hardened layer" refers to a layer obtained by cooling and hardening a softened, molten, or solution-state liquid crystalline composition. The term "cured layer" refers to a layer obtained by crosslinking the liquid crystalline composition through heat, a catalyst, light, and/or radiation into an insoluble and infusible, or hardly soluble and hardly fusible

stable state. Note that, the "cured layer" includes a cured layer obtained from a hardened layer of the liquid crystalline composition.

[0102] In the specification of the present invention, the term "liquid crystalline composition" refers to a composition having a liquid crystal phase and exhibiting liquid crystallinity. Examples of the liquid crystal phase include a nematic liquid crystal phase, a smectic liquid crystal phase, and a cholesteric liquid crystal phase. The liquid crystalline composition used in the present invention preferably has a nematic liquid crystal phase, to thereby obtain a highly transparent retardation film. The liquid crystal phase develops from a liquid crystal compound having in a molecular structure a mesogenic group containing a cyclic unit or the like.

[0103] A content of the liquid crystal compound in the liquid crystalline composition is preferably 40 to 100 (weight ratio), more preferably 50 to 99 (weight ratio), and particularly preferably 70 to 98 (weight ratio) with respect to a total solid content as 100 . The liquid crystalline composition may contain various additives such as a leveling agent, a polymerization initiator, an aligner, a thermal stabilizer, a lubricant, a plasticizer, and an antistatic agent without inhibiting the purpose of the present invention.

[0104] Examples of the mesogenic group containing a cyclic unit or the like of the liquid crystal compound include a biphenyl group, a phenylbenzoate group, a phenylcyclohexane group, an azoxybenzene group, an azomethine group, an azobenzene group, a phenyl pyrimidine group, a diphenylacetylene group, a diphenylbenzoate group, a bicyclohexane group, a cyclohexylbenzene group, and a terphenyl group. A terminal of the cyclic unit may have a substituent such as a cyano group, an alkyl group, an alkoxy group, or a halogen group. Of those, a mesogenic group containing a cyclic unit or the like to be used preferably has a biphenyl group or a phenylbenzoate group.

[0105] The liquid crystal compound to be used preferably has at least one polymerizable functional group in a part of a molecule. Examples of the polymerizable functional group include an acryloyl group, a methacryloyl group, an epoxy group, and a vinyl ether group. Of those, an acryloyl group or a methacryloyl group is preferably used. Further, the liquid crystal compound preferably has two or more polymerizable functional groups in a part of a molecule, to thereby improve durability by a crosslinked structure formed through a polymerization reaction. A specific example of a liquid crystal compound having two polymerizable functional groups in a part of a molecule includes "Paliocolor LC242" (trade name, available from BASF Aktiengesellschaft).

[0106] The retardation film used for the positive C plate more preferably includes a liquid crystalline composition containing a liquid crystal compound described in JP 2002-174725 A, and is a hardened layer or cured layer obtained by homeotropically aligning the liquid crystalline composition. The retardation film used for the positive C plate particularly preferably includes a liquid crystalline composition containing a liquid crystal polymer represented by the following general formula (2), and is a hardened layer or cured layer obtained by homeotropically aligning the liquid crystalline composition. The retardation film used for the positive C plate most preferably includes a liquid crystalline composi-

tion containing a liquid crystal polymer represented by the following general formula (2) and a liquid crystal compound having at least one polymerizable functional group in a part of a molecule, and is a hardened layer or cured layer obtained by homeotropically aligning the liquid crystalline composition. Such a liquid crystalline composition can provide a highly transparent retardation film with excellent optical uniformity.

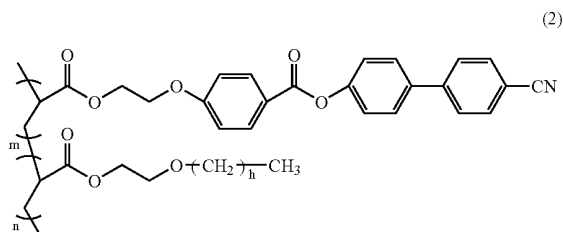

In the general formula (2), h represents an integer of 14 to 20. When a sum of m and n is 100, m is 50 to 70 and n is 30 to 50.

[0107] An example of a method of obtaining a homeotropically aligned liquid crystalline composition is a method involving applying a molten product or solution of a liquid crystalline composition on a substrate subjected to alignment treatment. A preferred example thereof includes a method involving applying on a substrate subjected to alignment treatment a solution (also referred to as application solution) prepared by dissolving a liquid crystalline composition in a solvent. Such a method can provide a retardation film with little alignment defects (also referred to as disclination) of the liquid crystalline composition.

[0108] The application solution may be prepared by using a commercially available solution of a liquid crystalline composition, or by adding a solvent to a commercially available solution containing a liquid crystalline composition. Alternatively, the application solution may be prepared by: dissolving a solid content of a liquid crystalline composition in various solvents; or adding various additives to a liquid crystal compound as required and adding a solvent to dissolve the additives.

[0109] A total solid content of the application solution varies depending on a solubility, an application viscosity, wetting property with respect to a substrate, a thickness after application, or the like. However, the solid content is generally 2 to 100 (weight ratio), more preferably 10 to 50 (weight ratio), and particularly preferably 20 to 40 (weight ratio) with respect to the solvent as 100. A solid content thereof within the above ranges can provide a retardation film with high surface uniformity.

[0110] A liquid substance capable of uniformly dissolving a liquid crystalline composition to prepare a solution may be employed as the solvent. Examples of the solvent include: a nonpolar solvent such as benzene or hexane; and a polar solvent such as water or alcohol. Further examples of the solvent include: an inorganic solvent such as water; and an organic solvent such as alcohols, ketones, ethers, esters, aliphatic and aromatic hydrocarbons, halogenated hydrocarbons, amides, and cellosolves. The solvent is preferably at

least one solvent selected from cyclopentanone, cyclohexanone, methyl isobutyl ketone, methyl ethyl ketone, toluene, ethyl acetate, and tetrahydrofuran. Such solvent provides no adverse effects on the substrate in practical use such as corrosion and is capable of dissolving the liquid crystalline composition sufficiently.

[0111] The substrate is not particularly limited, and examples thereof that may be used include: a glass substrate such as a glass sheet or a quartz substrate; a polymer substrate such as a plastic film or a plastic substrate; a metal substrate such as an aluminum substrate or an iron substrate; an inorganic substrate such as a ceramic substrate; and a semiconductor substrate such as a silicon wafer. A polymer substrate is particularly preferred because it is excellent in smoothness of a substrate surface and wetting property with a liquid crystalline composition, and allows continuous production by using rollers so as to significantly improve productivity.

[0112] Examples of a material forming the polymer substrate include a thermosetting resin, a UV-curable resin, a thermoplastic elastomer, and a biodegradable plastic. Of those, a thermoplastic resin is preferably used. The thermoplastic resin may be a noncrystalline polymer or a crystalline polymer. The noncrystalline polymer has excellent transparency, and thus has an advantage in that a retardation film (positive C plate) can be used for a liquid crystal panel or the like as it is without being peeled off from a substrate. In contrast, the crystalline polymer has excellent rigidity, strength, and chemical resistance, and thus has an advantage in that a retardation film (positive C plate) can be produced stably. Polyethylene terephthalate is most preferably used for the polymer substrate because of its excellent surface uniformity, strength, chemical resistance, and production stability. The polyethylene terephthalate substrate is generally peeled off after a homeotropically aligned liquid crystalline composition is hardened or cured.

[0113] Any appropriate alignment treatment may be selected in accordance with the kind of liquid crystal compound, the material for the substrate, and the like. Specific examples thereof include: substrate surface direct alignment treatment (A); substrate surface indirect alignment treatment (B); and substrate surface deformation alignment treatment (C). In the specification of the present invention, the term "substrate surface direct alignment treatment (A)" refers to a method involving: forming a thin layer of an aligner on a substrate surface through a method such as solution application (wet treatment), or plasma polymerization or sputtering (dry treatment); and adjusting an alignment direction of a liquid crystal compound in a specific direction by utilizing interaction between the aligner and the liquid crystal compound. The term "substrate surface indirect alignment treatment (B)" refers to a method involving: applying a liquid crystalline composition having an aligner dissolved in advance on a substrate surface; and adjusting an alignment direction of a liquid crystal compound in a specific direction by utilizing a phenomenon of the aligner permeating from the liquid crystalline composition and adsorbing on the substrate surface and by utilizing interaction between the aligner and the liquid crystal compound. The term "substrate surface deformation alignment treatment (C)" refers to a method involving: deforming a substrate surface for forming a rough surface; and adjusting an alignment direction of a liquid crystal compound in a specific direction by utilizing

interaction between the rough surface and the liquid crystal compound. Of those, the substrate surface direct alignment treatment (A) is preferably used in the present invention because this treatment has excellent aligning ability of the liquid crystal compound, to thereby provide a highly transparent retardation film with excellent optical uniformity.

[0114] Specific examples of the aligner subjected to solution application on the substrate surface include lecithin, stearic acid, hexadecyltrimethylammonium bromide, octadecylamine hydrochloride, a monobasic chromium carboxylate complex (such as a chromium myristate complex or a chromium perfluoronanoate complex), and an organic silane (such as a silane coupling agent or siloxane) Specific examples of the aligner subjected to plasma polymerization on the substrate surface include perfluorodimethylcyclohexane and tetrafluoroethylene. A specific example of the aligner subjected to sputtering on the substrate surface is polytetrafluoroethylene. Of those, an organic silane is particularly preferably used as the aligner because of its excellent workability, product quality, and aligning ability of the liquid crystal compound. A specific example of the organic silane as the aligner is "Ethyl silicate" (trade name, available from COLCOAT Co., Ltd.) containing tetraethoxysilane as a main component.

[0115] In addition to the methods described above, the aligner may be prepared by: using a commercially available aligner, or a commercially available solution or dispersion containing an aligner; adding a solvent to a commercially available aligner, or to a commercially available solution or dispersion containing an aligner; or dissolving or dispersing a solid content of an aligner in various solvents.

[0116] A method of applying the application solution on the substrate surface is not particularly limited. For example, an application method employing any appropriate coater may be used. Specific examples of the coater include a reverse roll coater, a positive rotation roll coater, a gravure coater, a knife coater, a rod coater, a slot orifice coater, a curtain coater, a fountain coater, an air doctor coater, a kiss coater, a dip coater, a bead coater, a blade coater, a cast coater, a spray coater, a spin coater, an extrusion coater, and a hot melt coater. Of those, preferred examples of the coater used in the present invention include a reverse roll coater, a positive rotation roll coater, a gravure coater, a rod coater, a slot orifice coater, a curtain coater, a fountain coater, and a spin coater. An application method employing the above-mentioned coater can provide a very thin retardation film having excellent surface uniformity and optical uniformity.

[0117] A method of hardening and/or curing a liquid crystalline composition may be employed as a method of fixing a homeotropically aligned liquid crystalline composition in accordance with the kind of liquid crystal compound to be used. For example, in a case where a liquid crystalline composition contains a liquid crystal polymer as a liquid crystal compound, a molten product or solution containing the liquid crystal polymer is hardened, to thereby provide sufficient mechanical strength for practical use. Meanwhile, in a case where a liquid crystalline composition contains a liquid crystal monomer as a liquid crystal compound, hardening of a liquid crystal monomer solution may not provide sufficient mechanical strength. In this case, a polymerizable liquid crystal monomer having at least one polymerizable functional group in a part of a molecule is

used, is irradiated with UV light, and is cured, to thereby provide sufficient mechanical strength for practical use.

[0118] A light source to be used for irradiation of UV light include an ultra-high pressure mercury lamp, a flash UV lamp, a high pressure mercury lamp, a low pressure mercury lamp, a deep UV lamp, a xenon lamp, a xenon flash lamp, and a metal halide lamp. UV light emitted from the light source may be non-polarized light or polarized light.

[0119] A wavelength of the light source to be used for UV irradiation may be determined in accordance with a light absorption wavelength range of a polymerizable functional group of the liquid crystal compound to be used in the present invention, but is generally 210 to 380 nm, and preferably 250 to 380 nm. A vacuum UV region of 100 to 200 nm of the light source is preferably cut through a filter or the like for suppressing a photo decomposition reaction of the liquid crystal compound. A wavelength within the above ranges allows sufficient curing of the liquid crystalline composition through a crosslinking reaction, and fixing of an alignment of the liquid crystalline composition.

[0120] An amount of UV irradiation is preferably 100 to 1,500 mJ/cm², and more preferably 100 to 800 mJ/cm². An amount of UV irradiation within the above ranges allows sufficient curing of the liquid crystalline composition through a crosslinking reaction, and fixing of an alignment of the liquid crystalline composition on the substrate.

[0121] A temperature inside an irradiation device at the above-mentioned amount of UV irradiation (also referred to as irradiation temperature) is not particularly limited, but irradiation is preferably performed while the temperature is maintained equal to or lower than a liquid crystal phase-isotropic phase transition temperature (Ti) of the liquid crystalline composition to be used in the present invention. The irradiation temperature is preferably Ti-5° C. or lower, and more preferably Ti-10° C. or lower. To be specific, the irradiation temperature is preferably 15 to 90° C., and more preferably 15 to 60° C. An irradiation temperature within the above ranges allows formation of a highly uniform retardation film.

[0122] The liquid crystal phase-isotropic phase transition temperature (Ti) can be determined by: holding the liquid crystalline composition to be used in the present invention between two glass slides; placing the whole on a temperature controller "LK-600PM" (trade name, manufactured by Japan Hightech Corporation); observing the whole under heating with a polarization microscope where two polarizers are placed in a cross Nicol arrangement; and measuring a temperature at which a dark field appears instead of a light field.

[0123] A specific method of maintaining the irradiation temperature constant is not particularly limited, and may be appropriately selected from heating methods or temperature control methods using: an air-circulating thermostatic oven in which hot air or cool air circulates; a heater using microwaves, far infrared rays, or the like; a heated roller for temperature adjustment; a heat pipe roller; and a heated metal belt.

[0124] In the present invention, the substrate having the application solution applied thereon may be subjected to drying treatment before and/or after UV irradiation. A temperature in the drying treatment (drying temperature) is not

particularly limited, but is preferably within a temperature range in which the liquid crystalline composition has a liquid crystal phase. Further, the drying temperature is preferably a glass transition temperature (T_g) of the substrate or lower. The drying temperature is preferably 50 to 130° C., and more preferably 80 to 100° C. A temperature within the above ranges allows formation of a highly uniform retardation film.

[0125] A time period for the drying treatment (drying time) is not particularly limited, but is preferably 1 to 20 minutes, more preferably 1 to 15 minutes, and most preferably 2 to 10 minutes for obtaining a retardation film with favorable optical uniformity.

[0126] The retardation film used for the positive C plate has a light transmittance of preferably 80% or more, more preferably 85% or more, and particularly preferably 90% or more measured by using light of a wavelength of 590 nm at 23° C. The positive C plate preferably has a similar light transmittance.

[0127] The retardation film used for the positive C plate has a thickness direction birefringence (n_x-n_z) of preferably -0.20 to -0.03, more preferably -0.15 to -0.05, and particularly preferably -0.12 to -0.05 determined by using light of a wavelength of 589 nm at 23° C. A thickness direction birefringence within the above ranges can provide a thin retardation film with little unevenness in in-plane retardation values.

[0128] The retardation film used for the positive C plate may have any appropriate thickness depending on the purpose or the laminate structure of the positive C plate. In a case where the positive C plate is formed of a single retardation film, the retardation film has a thickness equal to a total thickness of the positive C plate. Further, in a case where the positive C plate has a laminate structure, a thickness of each retardation film is set such that a total thickness of the retardation films is equal to a preferred total thickness of the positive C plate. The retardation films may each have an identical thickness or a different thickness. To be specific, the thickness of the retardation film is preferably 0.1 to 100 μm, more preferably 0.1 to 80 μm, and particularly preferably 0.1 to 50 μm. A thickness of the retardation film within the above ranges can provide a retardation film with excellent mechanical strength and display uniformity.

F. Isotropic Optical Element

[0129] Referring to FIGS. 1, 2A, and 2B, the isotropic optical element 50 is arranged between the liquid crystal cell 10 and the second polarizer 20'. In this way, the isotropic optical element serves as a protective layer on a liquid crystal cell side of the polarizer and prevents deterioration of the polarizer, to thereby maintain high display properties of the liquid crystal panel for a long period of time.

[0130] In the specification of the present invention, the term "isotropic optical element" refers to an optical element satisfying a refractive index profile of n_x=n_y=n_z (where, n_x and n_y represent main in-plane refractive indices and n_z represents a thickness direction refractive index). The specification of the present invention includes not only a case where n_x, n_y, and n_z are exactly equal, but also a case where n_x, n_y, and n_z are substantially equal. The phrase "a case where n_x, n_y, and n_z are substantially equal" as used herein includes a case where an in-plane retardation value (R_e

[590]) is 10 nm or less and a thickness direction retardation value (R_{th}[590]) is 10 nm or less, for example.

F-1. Optical Properties of Isotropic Optical Element

[0131] R_e[590] of the isotropic optical element used in the present invention is preferably as small as possible for increasing contrast ratios in a normal direction and an oblique direction of the liquid crystal display apparatus. R_e[590] is preferably 5 nm or less, and most preferably 3 nm or less.

[0132] R_{th}[590] of the isotropic optical element is preferably as small as possible for increasing a contrast ratio in an oblique direction of the liquid crystal display apparatus. R_{th}[590] is preferably 7 nm or less, and most preferably 5 nm or less. R_{th}[590] within the above ranges can eliminate adverse effects of R_{th} on display properties of the liquid crystal display apparatus.

F-2. Means for Arranging Isotropic Optical Element

[0133] Referring to FIGS. 2A and 2B, any appropriate method may be employed as a method of arranging the isotropic optical element 50 between the liquid crystal cell 10 and the second polarizer 20' depending on the purpose. The isotropic optical element 50 is preferably bonded to the liquid crystal cell 10 and the second polarizer 20' by providing an adhesive layer or pressure sensitive adhesive layer (not shown) on each side of the isotropic optical element 50. In this way, contrast of a liquid crystal display apparatus employing the isotropic optical element 50 can be increased.

[0134] A thickness of the adhesive layer or pressure sensitive adhesive layer may be appropriately determined in accordance with intended use, adhesive strength, and the like, and is generally 1 to 500 μm, preferably 5 to 200 μm, and particularly preferably 10 to 100 μm.

[0135] Any appropriate adhesive or pressure sensitive adhesive may be employed for forming the adhesive layer or pressure sensitive adhesive layer. Examples thereof include those each containing as a base polymer a polymer such as an acrylic polymer, a silicone-based polymer, polyester, polyurethane, polyamide, polyvinyl ether, a vinyl acetate/vinyl chloride copolymer, modified polyolefin, an epoxy-based polymer, a fluorine-based polymer, or a rubber-based polymer (such as a natural rubber-based polymer or a synthetic rubber-based polymer), which can be appropriately selected and used. In particular, in a case where one adherend is a substrate (typically, glass substrate) used for the liquid crystal cell, a pressure sensitive adhesive is preferably used because when axis shift occurs during attaching of the polarizer, the polarizer may be peeled off (also referred to as reworked) for reusing the liquid crystal cell. An acrylic pressure sensitive adhesive containing an acrylic polymer as a base polymer is preferably used as a pressure sensitive adhesive used for attaching the isotropic optical element 50 to the surface of the liquid crystal cell 10 from the viewpoints of excellent optical transparency, appropriate pressure sensitive adhesive properties such as wetting property, agglomeration property, and adhesiveness, and excellent weatherability and thermal resistance. A specific example thereof includes a double-face optical tape "SK-2057" (trade name, available from Soken Chemical & Engineering Co., Ltd.) containing an acrylic pressure sensitive adhesive as a pressure sensitive adhesive layer.

[0136] In a case where n_x and n_y of the isotropic optical element 50 are exactly equal, the isotropic optical element 50 exhibits no in-plane birefringence and its slow axis is not detected. Thus, the isotropic optical element 50 may be arranged independently from the absorption axis of the second polarizer 20'. In a case where n_x and n_y of the isotropic optical element 50 are substantially equal but are slightly different, its slow axis may be detected. In this case, the isotropic optical element 50 is preferably arranged such that its slow axis is substantially parallel or perpendicular to the absorption axis of the second polarizer 20'. In the specification of the present invention, the phrase "substantially parallel" includes a case where the slow axis of the isotropic optical element 50 and the absorption axis of the second polarizer 20' form an angle of $0^\circ \pm 2.0^\circ$, preferably $0^\circ \pm 1.0^\circ$, and more preferably $0^\circ \pm 0.5^\circ$. The phrase "substantially perpendicular" includes a case where the slow axis of the isotropic optical element 50 and the absorption axis of the second polarizer 20' form an angle of $90^\circ \pm 2.0^\circ$, preferably $90^\circ \pm 1.0^\circ$, and more preferably $90^\circ \pm 0.5^\circ$. An angle greatly departing from the above ranges tends to cause reduction in contrast of a liquid crystal display apparatus employing the isotropic optical element 50.

F-3. Structure of Isotropic Optical Element

[0137] A structure (laminate structure) of the isotropic optical element is not particularly limited as long as the optical properties as described in the above section F-1 are satisfied. To be specific, the isotropic optical element may be a single optical film, or a laminate of two or more optical films. The isotropic optical element as a laminate may include an adhesive layer or a pressure sensitive adhesive layer for attaching the optical films. The optical film may be an isotropic film or a retardation film as long as the isotropic optical element has substantially optical isotropy. In a case where the isotropic optical element as a laminate includes two retardation films, the retardation films are preferably arranged such that the respective slow axes are perpendicular to each other, to thereby reduce in-plane retardation values. Further, the retardation films having opposite signs of thickness direction retardation values are preferably laminated, to thereby reduce thickness direction retardation values.

[0138] A total thickness of the isotropic optical element is preferably 10 to 200 μm , more preferably 15 to 150 μm , and particularly preferably 20 to 100 μm . A thickness within the above ranges can provide an isotropic optical element with excellent optical uniformity.

F-4. Optical Film Used for Isotropic Optical Element

[0139] The optical film used for the isotropic optical element is preferably an isotropic film. In the specification of the present invention, the term "isotropic film" refers to a film having a small difference in optical properties in three-dimensional directions and having substantially no anisotropic optical properties such as birefringence. Note that the phrase "having substantially no anisotropic optical properties" indicates that isotropy includes a case where slight birefringence provides no adverse effects on display properties of a liquid crystal display apparatus in practical use.

[0140] Any appropriate method may be employed as a method of obtaining the isotropic film. Specific examples

thereof include extrusion, solvent casting, and inflation. Extrusion is preferably used for forming an isotropic film.

[0141] Examples of a material forming the isotropic film include: general purpose plastics such as polyethylene, polypropylene, polynorbornene, polyvinyl chloride, a cellulose ester, polystyrene, an ABS resin, an AS resin, polymethylmethacrylate, polyvinyl acetate, and polyvinylidene chloride; general purpose engineering plastics such as polyamide, polyacetal, polycarbonate, modified polyphenylene ether, polybutylene terephthalate, and polyethylene terephthalate; and super engineering plastics such as polyphenylene sulfide, polysulfone, polyethersulfone, polyetheretherketone, polyarylate, a liquid crystal polymer, polyamideimide, polyimide, and polytetrafluoroethylene. The isotropic film may be used after appropriate polymer modification. Examples of the polymer modification include copolymerization, branching, crosslinking, and modifications in molecular terminals and stereoregularity. Two or more kinds of isotropic films may be used in combination.

[0142] The material forming the isotropic film to be used is preferably a polymer film containing as a main component at least one resin selected from polynorbornene, a cellulose ester, an isobutylene/N-methylmaleimide copolymer, and an acrylonitrile/styrene copolymer from the viewpoints of excellent transparency, mechanical strength, thermal stability, and water barrier property, small absolute value of photoelastic coefficient, and excellent adhesiveness with the polarizer.

[0143] Polynorbornene obtained through addition copolymerization of ethylene and a norbornene-based monomer is particularly preferably used from the viewpoints of particularly small absolute value of photoelastic coefficient and hardly developing retardation values. Polynorbornene containing a repeating unit represented by the following general formula (3) is most preferably used.

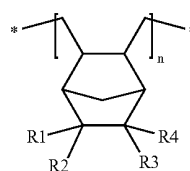

(3)

In the general formula (3): R1 to R4 each independently represent a group selected from hydrogen, a halogen, a halogenated alkyl group having 1 to 5 carbon atoms, an alkyl group having 1 to 5 carbon atoms, an alkoxy group having 1 to 5 carbon atoms, an alkoxycarbonyl group having 1 to 5 carbon atoms, an alkylcarbonyloxy group having 1 to 5 carbon atoms, and substituted derivatives thereof; and n represents an integer of 1 or more. Most preferably, R1 to R4 each represent a hydrogen atom.

[0144] The isotropic film used for the isotropic optical element has a light transmittance of preferably 80% or more, more preferably 85% or more, and particularly preferably 90% or more measured by using light of a wavelength of 590 nm at 23°C . The isotropic optical element preferably has a similar light transmittance.

[0145] An absolute value of photoelastic coefficient $C[590]$ (m^2/N) of the isotropic film is preferably 2.0×10^{-13}

to 1.0×10^{-10} , more preferably 1.0×10^{-12} to 1.0×10^{-10} , and particularly preferably 1.0×10^{-12} to 2.0×10^{-11} . An absolute value of photoelastic coefficient within the above ranges can provide a liquid crystal display apparatus with excellent display uniformity.

[0146] The isotropic film may have any appropriate thickness depending on the purpose or the laminate structure of the isotropic optical element. In a case where the isotropic optical element is formed of a single isotropic film, the isotropic film has a thickness equal to a total thickness of the isotropic optical element. Further, in a case where the isotropic optical element has a laminate structure, a thickness of each isotropic film is set such that a total thickness of the isotropic films is equal to a preferred total thickness of the isotropic optical element. The isotropic films may each have an identical thickness or a different thickness. To be specific, the thickness of the isotropic film is preferably 10 to 100 μm , more preferably 10 to 80 μm , and particularly preferably 10 to 50 μm . A thickness within the above ranges can provide an isotropic film with excellent mechanical strength and display uniformity.

G. Liquid Crystal Display Apparatus

[0147] The liquid crystal panel of the present invention may be used for: a liquid crystal display apparatus such as a personal computer, a liquid crystal television, a cellular phone, or a personal digital assistance (PDA); or an image display apparatus such as an organic electroluminescence display (organic EL), a projector, a projection television, or a plasma television. In particular, the liquid crystal panel of the present invention is preferably used for a liquid crystal display apparatus, and particularly preferably used for a liquid crystal television.

[0148] FIG. 3 is a schematic sectional view of a liquid crystal display apparatus according to a preferred embodiment of the present invention. A liquid crystal display apparatus 200 is provided with: a liquid crystal panel 100; protective layers 60 and 60' arranged on both sides of the liquid crystal panel; surface treated layers 70 and 70' arranged on outer sides of the protective layers 60 and 60'; a brightness enhancement film 80 arranged on an outer side (backlight side) of the surface treated layer 70'; a prism sheet 110; a light guide plate 120; and backlight 130. Treated layers subjected to hard coat treatment, antireflection treatment, anti-sticking treatment, diffusion treatment (also referred to as anti-glare treatment), or the like is used as the surface treated layers 70 and 70'. A polarization separation film having a polarization selection layer "D-BEF series" (trade name, available from Sumitomo 3M Limited, for example) or the like is used as the brightness enhancement film. The above-described optical members are used, to thereby obtain a display apparatus with better display properties. According to another embodiment, the optical members shown in FIG. 3 may be partly omitted or replaced by other members in accordance with the drive mode or application of the liquid crystal cell to be used as long as the effects of the present invention are obtained.

[0149] The liquid crystal display apparatus provided with the liquid crystal panel of the present invention has a contrast ratio (YW/YB) of preferably 15 to 200, more preferably 25 to 200, and particularly preferably 40 to 200 at an azimuth angle of 45° and a polar angle of 60° .

[0150] The liquid crystal display apparatus provided with the liquid crystal panel of the present invention has a color

shift (Δab value) of preferably 0.05 to 1.0, more preferably 0.05 to 0.6, and particularly preferably 0.05 to 0.5 at an azimuth angle of 45° and a polar angle of 60° .

H. Application of Liquid Crystal Panel of the Present Invention

[0151] The application of the liquid crystal panel and liquid crystal display apparatus of the present invention is not particularly limited, but the liquid crystal panel and liquid crystal display apparatus of the present invention may be used for various applications such as: office automation (OA) devices such as a personal computer monitor, a laptop personal computer, and a copying machine; portable devices such as a cellular phone, a watch, a digital camera, a personal digital assistance (PDA), and a portable game machine; home appliances such as a video camera, a liquid crystal television, and a microwave; in-car devices such as a back monitor, a car navigation system monitor, and a car audio; display devices such as a commercial information monitor; security devices such as a surveillance monitor; and nursing care/medical devices such as a nursing monitor and a medical monitor.

[0152] In particular, the liquid crystal panel and liquid crystal display apparatus of the present invention are preferably used for a large liquid crystal television. A liquid crystal television employing the liquid crystal panel and liquid crystal display apparatus of the present invention has a screen size of preferably wide 17-inch (373 mm \times 224 mm) or more, more preferably wide 23-inch (499 mm \times 300 mm) or more, particularly preferably wide 26-inch (566 mm \times 339 mm) or more, and most preferably wide 32-inch (687 mm \times 412 mm) or more.

[0153] The present invention will be described in more detail by using the following examples and comparative examples. However, the present invention is not limited to the examples. Analysis methods used in the examples are described below.

(1) Method of Determining Single Axis Transmittance and Degree of Polarization:

[0154] The single axis transmittance and degree of polarization were determined at 23°C . by using a spectrophotometer "DOT-3" (trade name, manufactured by Murakami Color Research Laboratory).

(2) Method of Determining Molecular Weight:

[0155] The molecular weight was calculated through gel permeation chromatography (GPC) by using polystyrene as a standard sample. To be specific, the molecular weight was determined under the following measurement conditions by using the following apparatus and instruments.

[0156] Analyzer: "HLC-8120GPC", manufactured by Tosoh Corporation

[0157] Column: TSKgel SuperHM-H/H4000/H3000/H2000

[0158] Column size: 6.0 mm I.D. \times 150 mm

[0159] Eluant: tetrahydrofuran

[0160] Flow rate: 0.6 ml/minute

[0161] Detector: RI

[0162] Column temperature: 40° C.

[0163] Injection amount: 20 μ l

(3) Method of Measuring Thickness:

[0164] A thickness of less than 10 μ m was measured by using a thin film thickness spectrophotometer "Multichannel photodetector MCPD-2000" (trade name, manufactured by Otsuka Electronics Co., Ltd.). A thickness of 10 μ m or more was measured by using a digital micrometer "KC-351C-type" (trade name, manufactured by Anritsu Corporation).

(4) Method of Determining Retardation Values (Re, Rth):

[0165] The retardation values were determined by using an automatic birefringence analyzer "KOBRA-21ADH" (trade name, manufactured by Oji Scientific Instruments) based on a parallel Nicol rotation method by using light of a wavelength of 590 nm at 23° C. Light of a wavelength of 480 nm was also used for wavelength dispersion measurement.

(5) Method of Measuring Refractive Index of Film:

[0166] The refractive index of the film was determined by measuring refractive indices by using an Abbe refractometer "DR-M4" (trade name, manufactured by Atago Co., Ltd.) by using light of a wavelength of 589 nm at 23° C.

(6) Method of Measuring Transmittance:

[0167] The transmittance was measured by using a UV-vis spectrophotometer "V-560" (trade name, manufactured by JASCO Corporation) by using light of a wavelength of 590 nm at 23° C.

(7) Method of Determining Photoelastic Coefficient:

[0168] The retardation values (23° C./wavelength of 590 nm) at a center of a sample having a size of 2 cm \times 10 cm were determined under stress (5 to 15 N) by using a spectroscopic ellipsometer "M-220" (trade name, manufactured by JASCO Corporation) while both ends of the sample were held, and the photoelastic coefficient was calculated from a slope of a function of the stress and the retardation values.

(8) Method of Determining Contrast Ratio of Liquid Crystal Display Apparatus:

[0169] Measurement was performed in a dark room at 23° C. by using the following method, liquid crystal cell, and measurement apparatus. A white image and a black image were displayed on a liquid crystal display apparatus, and Y values of an XYZ display system at an azimuth angle of 45° and polar angle of 60° of a display screen were measured by using "EZ Contrast 160D" (trade name, manufactured by ELDIM SA). A contrast ratio "YW/YB" in an oblique direction was calculated from a Y value (YW) of the white image and a Y value (YB) of the black image. Note that, the azimuth angle of 45° refers to a direction rotated by 45° in a counter clockwise direction with respect to a longer side of the panel at 0°. The polar angle of 60° refers to a direction inclined by 60° with respect to a normal direction of the display screen at 0°.

[0170] Liquid crystal cell: liquid crystal cell installed in "KLV-17HR2" (trade name, manufactured by Sony Corporation)

[0171] Panel size: 375 mm \times 230 mm

(9) Method of Determining Color Shift of Liquid Crystal Display Apparatus:

[0172] A black image was displayed on the liquid crystal display apparatus, and color tones (a value and b value) were measured in all azimuth directions (0° to 360°) at a polar angle of 60° by using "EZ Contrast 160D" (trade name, manufactured by ELDIM SA). Average values of the a values and the b values in all azimuth directions (0 to 360°) at a polar angle of 60° were respectively represented by an a_{ave} value and a b_{ave} value, and an a value and a b value at an azimuth angle of 45° and a polar angle of 60° were respectively represented by an a_{45° value and a b_{45° value. The color shift (Δab value) in an oblique direction was calculated from the following expression: $\{(a_{45^\circ} - a_{ave})^2 + (b_{45^\circ} - b_{ave})^2\}^{1/2}$. Note that, the azimuth angle of 45° refers to a direction rotated by 45° in a counter clockwise direction with respect to a longer side of the panel at 0°. The polar angle of 60° refers to a direction viewed from 60° with respect to a normal direction of the panel at 0°.

Production of Negative biaxial Optical Element

REFERENCE EXAMPLE 1

[0173] A commercially available polymer film "KC12UR" (trade name, thickness of 120 μ m, available from Konica Minolta Holdings, Inc.) containing a cellulose ester as a main component was longitudinally uniaxially stretched 1.30 times in an air-circulating thermostatic oven at 150° C. (temperature measured at a distance of 3 cm from a back surface of the film, temperature fluctuation of $\pm 1^\circ$ C.) by using a roll stretching machine while a longitudinal direction of the film was held, to thereby produce a retardation film A. Table 1 shows properties of the obtained retardation film A. The polymer film (before stretching) had Re[590] of 12 nm and Rth[590] of 113 rim.

REFERENCE EXAMPLE 2

[0174] A polymer film (thickness of 160 μ m) was formed through solvent casting by using a cellulose ester (prepared in accordance with Example 1 of JP 2001-188128 A) containing as a main component a mixed organic acid ester having a degree of acetyl substitution of 2.0 and a degree of propionyl substitution of 0.8 in which hydroxyl groups of cellulose are substituted partly by an acetyl group and partly by a propionyl group. The polymer film was longitudinally uniaxially stretched 1.15 times in an air-circulating thermostatic oven at 150° C. (temperature measured at a distance of 3 cm from a back surface of the film, temperature fluctuation of $\pm 1^\circ$ C.) by using a roll stretching machine while a longitudinal direction of the film was held, to thereby produce a retardation film B. Table 1 shows the properties of the obtained retardation film B. The polymer film (before stretching) had Re[590] of 12 nm and Rth[590] of 113 nm.

REFERENCE EXAMPLE 3

[0175] A commercially available polymer film "ZEONOR ZF14-060" (trade name, thickness of 60 μ m, glass transition temperature of 136° C., available from Zeon Corporation) containing polynorborene as a main component was transversely uniaxially stretched 1.8 times in a width direction in an air-circulating thermostatic oven at 140° C. (temperature measured at a distance of 3 cm from a back surface of the film, temperature fluctuation of $\pm 1^\circ$ C.) by using a tenter

stretching machine while a longitudinal direction of the film was held, to thereby produce a retardation film C. Table 1 shows the properties of the obtained retardation film C. The polymer film (before stretching) had Re[590] of 2.7 nm and Rth[590] of 0.5 nm.

Production of Positive C Plate

REFERENCE EXAMPLE 4

[0176] An ethyl silicate solution (2 wt % mixed solution of ethyl acetate and isopropyl alcohol, available from COLCOAT Co., Ltd.) was applied on a commercially available polyethylene terephthalate film "IS-27E" (trade name, thickness of 75 μm , available from Toray Industries, Inc.) by using a gravure coater, and the whole was dried in an air-circulating thermostatic oven at 130° C. (temperature fluctuation of $\pm 1^\circ\text{C}$.) for 1 minute, to thereby produce a polyethylene terephthalate film having a glass polymer film (thickness of 0.1 μm).

[0177] 5 parts by weight of a liquid crystal polymer (weight average molecular weight of 5,000) represented by the following formula (4), 20 parts by weight of a commercially available liquid crystal compound "Paliocolor LC242" (trade name, available from BASF Aktiengesellschaft) having a phenylbenzoate group as a mesogenic group and having two polymerizable functional groups in a molecular structure, and 1.25 parts by weight of a photopolymerization initiator "IRGACURE 907" (tradename, available from Ciba Specialty Chemicals) were mixed, to thereby prepare a liquid crystalline composition. The liquid crystalline composition was dissolved in 75 parts by weight of cyclohexanone, to thereby prepare an application solution. The application solution was applied on the glass polymer film of the polyethylene terephthalate film by using a rod coater, and the whole was dried in an air-circulating thermostatic oven at 80° C. (temperature fluctuation of $\pm 1^\circ\text{C}$.) for 2 minutes and then cooled to room temperature (23° C.), to thereby form a hardened layer of a homeotropically aligned liquid crystalline composition on the substrate. The thus-formed layer was irradiated with UV light of 400 mJ/cm² (by using an irradiation device with a metal halide lamp as a light source, measured at a wavelength of 365 nm) in an air atmosphere at 30° C. from a side having the application solution applied thereon, to thereby form a cured layer of the homeotropically aligned liquid crystalline composition on the substrate. The substrate was peeled off, to thereby produce a retardation film

D. Table 1 Shows the Properties of the Retardation Film D.

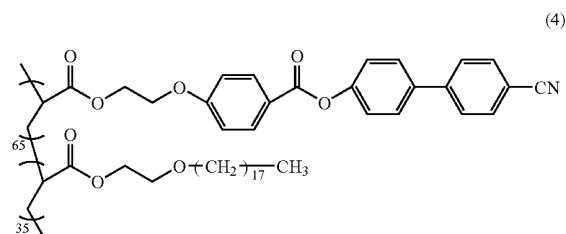

REFERENCE EXAMPLE 5

[0178] A retardation film E was produced in the same manner as in Reference Example 4 except that the applica-

tion thickness of the application solution was changed. Table 1 shows the properties of the retardation film E.

REFERENCE EXAMPLE 6

[0179] A retardation film F was produced in the same manner as in Reference Example 4 except that the application thickness of the application solution was changed. Table 1 shows the properties of the retardation film F.

TABLE 1

	Refer- ence Exam- ple 1	Refer- ence Exam- ple 2	Refer- ence Exam- ple 3	Refer- ence Exam- ple 4	Refer- ence Exam- ple 5	Refer- ence Exam- ple 6
Retardation film	A	B	C	D	E	F
Thickness (μm)	108	147	33	0.75	1.0	1.75
Transmit- tance (%)	90	90	90	92	91	91
Re[590] (nm)	101	85	110	0.1	0.1	0.1
Rth[590] (nm)	142	170	161	-75	-100	-175
Re[480]/ Re[590]	0.93	0.92	1.00	Not mea- sured	Not mea- sured	Not mea- sured
C[590] \times 10^{-12} (m ² /N)	21.0	20.8	3.1	Not mea- sured	Not mea- sured	Not Mea- sured

Production of Isotropic Optical Element

REFERENCE EXAMPLE 7

[0180] Pellets of polynorbornene "TOPAS" (trade name, glass transition temperature of 140° C., weight average molecular weight of 90,000, available from Ticona) obtained through addition copolymerization of ethylene and norbornene were dried at 100° C. for 5 hours. Then, the resultant was extruded at 270° C. by using a single-screw extruder of 40 mm Φ and a T-die of 400 mm width, and a sheet-like molten resin was cooled by using a cooling drum, to thereby produce a polymer film A having a width of about 600 mm and a thickness of 40 μm . Table 2 shows the properties of the polymer film A.

REFERENCE EXAMPLE 8

[0181] 20 parts by weight of polynorbornene "ARTON G" (trade name, available from JSR Corporation) was dissolved in 80 parts by weight of cyclopentanone (solvent), to thereby prepare a solution. The solution was applied on a commercially available cellulose ester film "UZ-TAC" (trade name, thickness of 40 μm , available from Fuji Photo Film Co., Ltd.) to an application thickness of 150 μm , so as to swell the cellulose ester film. The resultant was dried in an air-circulating thermostatic oven at 140° C. (temperature fluctuation of $\pm 1^\circ\text{C}$.) for 3 minutes to evaporate the solvent, to thereby form a polynorbornene layer on a surface of the cellulose ester film. The polynorbornene layer was peeled off, to thereby obtain a transparent cellulose ester film as a polymer film B. Table 2 shows the properties of the polymer film B. The cellulose ester film before swelling had Re[590] of 2.2 nm and Rth[590] of 39.8 nm.

REFERENCE EXAMPLE 9

[0182] 65 parts by weight of an alternating copolymer of isobutylene and N-methylmaleimide (N-methylmaleimide content of 50 mol % and glass transition temperature of 157° C.), 35 parts by weight of an acrylonitrile/styrene copolymer (acrylonitrile content of 27 mol %), and 1 part by weight of 2-[4,6-diphenyl-1,3,5-triazin-2-yl]-5-[(hexyl)oxy]-phenol (UV absorber) were formed into pellets by using an extruder. Then, the resultant was dried at 100° C. for 5 hours and extruded at 270° C. by using a single-screw extruder of 40 mmΦ and a T-die of 400 mm width, and a sheet-like molten resin was cooled by using a cooling drum, to thereby produce a polymer film C having a width of about 600 mm and a thickness of 40 μm. Table 2 shows the properties of the polymer film C.

REFERENCE EXAMPLE 10

[0183] A commercially available cellulose ester film "UZ-TAC" (trade name, thickness of 80 μm, available from Fuji Photo Film Co., Ltd.) as it is was used as a polymer film D. Table 2 shows the properties of the polymer film D.

TABLE 2

	Reference Example 7	Reference Example 8	Reference Example 9	Reference Example 10
Polymer film	A	B	C	D
Thickness(μm)	40	42	40	80
Transmittance(%)	91	90	91	91
Re[590](nm)	0.1	2.0	2.1	2.5
Rth[590](nm)	1.0	0.5	2.9	60.2
C[590] × 10 ⁻¹² (m ² /N)	4.8	17.8	5.1	14.0

Production of Polarizer

REFERENCE EXAMPLE 11

[0184] A polymer film "9P75R" (trade name, thickness of 75 μm, average degree of polymerization of 2,400, degree of saponification of 99.9 mol %, available from Kuraray Co., Ltd.) containing polyvinyl alcohol as a main component was uniaxially stretched 2.5 times by using a roll stretching machine while the polymer film was colored in a coloring bath maintained at 30° C. ± 3° C. and containing iodine and potassium iodide. Next, the polymer film was uniaxially stretched to a 6 times length of the original length of the polyvinyl alcohol film in an aqueous solution maintained at 60° C. ± 3° C. and containing boric acid and potassium iodide while a crosslinking reaction was performed. The obtained film was dried in an air circulating thermostatic oven at 50° C. ± 1° C. for 30 minutes, to thereby obtain polarizers P1 and P2 each having a moisture content of 26%, a thickness of 28 μm, a degree of polarization of 99.9%, and a single axis transmittance of 43.5%.

EXAMPLE 1

[0185] A liquid crystal panel was removed from a commercially available liquid crystal display apparatus "KLV-17HR2" (manufactured by Sony Corporation) provided with a liquid crystal cell of IPS mode. Polarizing plates arranged above and below the liquid crystal cell were removed, and glass surfaces (front and back surfaces) of the liquid crystal cell were washed. Then, the retardation film E produced in

Reference Example 5 as a positive C plate was attached to the surface on a viewer side of the liquid crystal cell such that a slow axis of the retardation film E was parallel (0° ± 0.2°) to a longer side of the liquid crystal cell by using an acrylic pressure sensitive adhesive layer (thickness of 20 μm). Next, the retardation film A produced in Reference Example 1 as a negative biaxial optical element was attached to the surface of the retardation film E such that a slow axis of the retardation film A was perpendicular (90° ± 0.2°) to the longer side of the liquid crystal cell by using an acrylic pressure sensitive adhesive layer (thickness of 10 μm). Further, the polarizer P1 produced in Reference Example 11 as a first polarizer was attached to the surface of the retardation film A such that an absorption axis of the polarizer P1 was parallel (0° ± 0.2°) to the longer side of the liquid crystal cell by using an acrylic pressure sensitive adhesive layer (thickness of 10 μm). In this case, the slow axis of the retardation film A and the absorption axis of the polarizer P1 were perpendicular (90° ± 0.4°) to each other.

[0186] Next, the polymer film A produced in Reference Example 7 as an isotropic optical element was attached to the surface on a backlight side of the liquid crystal cell such that a slow axis of the polymer film A was parallel (0° ± 0.2°) to a shorter side of the liquid crystal cell by using an acrylic pressure sensitive adhesive layer (thickness of 10 μm). Then, the polarizer P2 produced in Reference Example 11 as a second polarizer was attached to the surface of the polymer film A such that an absorption axis of the polarizer 2 was parallel (0° ± 0.2°) to the shorter side of the liquid crystal cell by using an acrylic pressure sensitive adhesive layer (thickness of 10 μm). In this case, the absorption axis of the polarizer P1 and the absorption axis of the polarizer P2 were perpendicular (90° ± 0.4°) to each other. In this way, a liquid crystal panel of O-mode having a structure similar to that of FIG. 2A was produced.

[0187] The liquid crystal panel was incorporated into the original liquid crystal display apparatus, and backlight was turned on for 10 minutes, to thereby measure a contrast ratio in an oblique direction and a color shift in an oblique direction. Table 3 shows the obtained results.

EXAMPLE 2

[0188] A liquid crystal panel was produced in the same manner as in Example 1 except that the retardation film B was used as the negative biaxial optical element instead of the retardation film A, to thereby measure a contrast ratio in an oblique direction and a color shift in an oblique direction. Table 3 shows the obtained results.

EXAMPLE 3

[0189] A liquid crystal panel was produced in the same manner as in Example 1 except that the retardation film C was used as the negative biaxial optical element instead of the retardation film A, to thereby measure a contrast ratio in an oblique direction and a color shift in an oblique direction. Table 3 shows the obtained results.

EXAMPLE 4

[0190] A liquid crystal panel was produced in the same manner as in Example 1 except that the retardation film D was used as the positive C plate instead of the retardation

film E, to thereby measure a contrast ratio in an oblique direction and a color shift in an oblique direction. Table 3 shows the obtained results.

EXAMPLE 5

[0191] A liquid crystal panel was produced in the same manner as in Example 1 except that the retardation film F was used as the positive C plate instead of the retardation film E, to thereby measure a contrast ratio in an oblique direction and a color shift in an oblique direction. Table 3 shows the obtained results.

EXAMPLE 6

[0192] A liquid crystal panel was produced in the same manner as in Example 1 except that the polymer film C was used as the isotropic optical element instead of the polymer film A, to thereby measure a contrast ratio in an oblique direction and a color shift in an oblique direction. Table 3 shows the obtained results.

COMPARATIVE EXAMPLE 1

[0193] A liquid crystal panel was produced in the same manner as in Example 1 except that the polymer film D produced in Reference Example 10 was used as the isotropic optical element instead of the polymer film A, to thereby measure a contrast ratio in an oblique direction and a color shift in an oblique direction. Table 3 shows the obtained results.

COMPARATIVE EXAMPLE 2

[0194] A liquid crystal panel was removed from a commercially available liquid crystal display apparatus "KLV-17HR2" (manufactured by Sony Corporation) provided with a liquid crystal cell of IPS mode in the same manner as in

polarizer P1 was parallel ($0^\circ \pm 0.2^\circ$) to the longer side of the liquid crystal cell by using an acrylic pressure sensitive adhesive layer (thickness of 10 μm). In other words, either the negative biaxial optical element or the positive C plate was not used.

[0195] Next, the polymer film A produced in Reference Example 7 as an isotropic optical element was attached to the surface on a backlight side of the liquid crystal cell such that the slow axis of the polymer film A was parallel ($0^\circ \pm 0.2^\circ$) to the shorter side of the liquid crystal cell by using an acrylic pressure sensitive adhesive layer (thickness of 10 μm). Then, the polarizer P2 produced in Reference Example 11 as a second polarizer was attached to the surface of the polymer film A such that the absorption axis of the polarizer P2 was parallel ($0^\circ \pm 0.2^\circ$) to the shorter side of the liquid crystal cell by using an acrylic pressure sensitive adhesive layer (thickness of 10 μm). In this case, the absorption axis of the polarizer P1 and the absorption axis of the polarizer P2 were perpendicular ($90^\circ \pm 0.4^\circ$) to each other.

[0196] A contrast ratio in an oblique direction and a color shift in an oblique direction of a liquid crystal display apparatus provided with the thus-obtained liquid crystal panel were measured in the same manner as in Example 1. Table 3 shows the obtained results.

COMPARATIVE EXAMPLE 3

[0197] A liquid crystal panel was produced in the same manner as in Example 1 except that the order for attaching the retardation film E and the retardation film A to the surface on a viewer side of the liquid crystal cell in Example 1 was reversed (that is, the retardation film A was arranged between the liquid crystal cell and the retardation film E), to thereby measure a contrast ratio in an oblique direction and a color shift in an oblique direction. Table 3 shows the obtained results.

TABLE 3

	Negative biaxial				Isotropic		Liquid crystal panel	
	optical element		Positive C plate		optical element Polymer film	Contrast ratio in oblique direction	Color shift in oblique direction	
	Retardation film	Re [590] (nm)	Rth [590] (nm)	Retardation film				Rth [590] (nm)
Example 1	A	101	142	E	-100	A	81.0	0.21
Example 2	B	85	170	E	-100	A	56.3	0.44
Example 3	C	110	161	E	-100	A	79.5	0.32
Example 4	A	101	142	D	-75	A	45.5	0.47
Example 5	A	101	142	F	-175	A	27.3	0.20
Example 6	A	101	142	E	-100	C	79.4	0.28
Comparative Example 1	A	101	142	E	-100	D	4.0	2.4
Comparative Example 2	Not used			Not used		A	13.9	1.2
Comparative Example 3	A	101	142	E	-100	A	2.5	5.5

Example 1. Polarizing plates arranged above and below the liquid crystal cell were removed, and glass surfaces (front and back surfaces) of the liquid crystal cell were washed. Then, the polarizer P1 produced in Reference Example 11 as a first polarizer was attached to the surface on a viewer side of the liquid crystal cell such that the absorption axis of the

[Evaluation]

[0198] As shown in each of Examples 1 to 6, the liquid crystal panel having the negative biaxial optical element, the positive C plate, and the isotropic optical element arranged as shown in FIG. 2A provided a liquid crystal display

apparatus with a large contrast ratio in an oblique direction and a small color shift in an oblique direction. In addition, the results actually confirm that the liquid crystal panel having a structure as shown in **FIG. 2B** provided a liquid crystal display apparatus with a large contrast ratio in an oblique direction and a small color shift in an oblique direction. The results of Examples 1 to 3 indicate that the negative biaxial optical element most preferably has $R_e[590]$ of about 100 nm for increasing a contrast ratio in an oblique direction. Further, the results of Examples 1, 4, and 5 indicate that the positive C plate most preferably has $R_{th}[590]$ of about -100 nm. Meanwhile, Comparative Example 1 provided a liquid crystal panel employing the polymer film D, which was hitherto used as a protective layer of a polarizer, instead of the polymer film A as the isotropic optical element. The liquid crystal panel provided only a liquid crystal display apparatus with a small contrast ratio in an oblique direction and a large color shift in an oblique direction. The liquid crystal panel of Comparative Example 2 employing no negative biaxial optical element and positive C plate similarly provided only a liquid crystal display apparatus with a small contrast ratio in an oblique direction and a large color shift in an oblique direction. In addition, the liquid crystal panel of Comparative Example 3 had the negative biaxial optical element and the positive C plate arranged in the reverse order of that of the liquid crystal panel of Example 1, and provided only a liquid crystal display apparatus with a small contrast ratio in an oblique direction and a large color shift in an oblique direction. That is, it is important that the negative biaxial optical element be arranged between the polarizer and the positive C plate.

[0199] As described above, the liquid crystal panel of the present invention is capable of increasing a contrast ratio in an oblique direction and reducing a color shift in an oblique direction, and thus is very useful for improving display properties of the liquid crystal display apparatus. Therefore, the liquid crystal panel of the present invention may suitably be used for a liquid crystal display apparatus or a liquid crystal television.

[0200] Many other modifications will be apparent to and be readily practiced by those skilled in the art without departing from the scope and spirit of the invention. It should therefore be understood that the scope of the appended claims is not intended to be limited by the details of the description but should rather be broadly construed.

What is claimed is:

1. A liquid crystal panel comprising:

a liquid crystal cell;

a first polarizer arranged on one side of the liquid crystal cell;

a second polarizer arranged on another side of the liquid crystal cell;

a negative biaxial optical element and a positive C plate arranged between the liquid crystal cell and the first polarizer; and

an isotropic optical element arranged between the liquid crystal cell and the second polarizer, wherein

the negative biaxial optical element is arranged between the first polarizer and the positive C plate.

2. A liquid crystal panel according to claim 1, wherein the liquid crystal cell comprises a liquid crystal layer containing homogeneously aligned liquid crystal molecules in the absence of an electric field.

3. A liquid crystal panel according to claim 2, wherein the liquid crystal layer has a refractive index profile of $n_x > n_y = n_z$.

4. A liquid crystal panel according to claim 3, wherein the liquid crystal cell comprises one of IPS mode, FFS mode, and FLC mode.

5. A liquid crystal panel according to claim 1, wherein an initial alignment direction of the liquid crystal cell is substantially parallel to a direction of an absorption axis of the second polarizer.

6. A liquid crystal panel according to claim 5, wherein the initial alignment direction of the liquid crystal cell is substantially parallel to a direction of an absorption axis of the polarizer arranged on a backlight side of the liquid crystal cell.

7. A liquid crystal panel according to claim 5, wherein the initial alignment direction of the liquid crystal cell is substantially perpendicular to a direction of an absorption axis of the polarizer arranged on a backlight side of the liquid crystal cell.

8. A liquid crystal panel according to claim 1, wherein a slow axis of the negative biaxial optical element is substantially perpendicular to an absorption axis of the first polarizer.

9. A liquid crystal panel according to claim 1, wherein the negative biaxial optical element has an in-plane retardation value ($R_e[590]$) of 50 to 180 nm determined by using light of a wavelength of 590 nm at 23° C.

10. A liquid crystal panel according to claim 9, wherein:

the negative biaxial optical element has a thickness direction retardation value ($R_{th}[590]$) of 110 to 250 nm determined by using light of a wavelength of 590 nm at 23° C.; and

the thickness direction retardation value ($R_{th}[590]$) is larger than $R_e[590]$.

11. A liquid crystal panel according to claim 1, wherein the negative biaxial optical element has $R_e[480]/R_e[590]$ of 0.8 to 1.2.

12. A liquid crystal panel according to claim 1, wherein the negative biaxial optical element comprises a stretched film of a polymer film containing a cellulose ester as a main component.

13. A liquid crystal panel according to claim 12, wherein the polymer film has an absolute value of photoelastic coefficient $C[590]$ (m^2/N) of 2.0×10^{-13} to 1.0×10^{-10} .

14. A liquid crystal panel according to claim 1, wherein the positive C plate has a thickness direction retardation value ($R_{th}[590]$) of -200 to -30 nm determined by using light of a wavelength of 590 nm at 23° C.

15. A liquid crystal panel according to claim 1, wherein the positive C plate comprises a single retardation film.

16. A liquid crystal panel according to claim 15, wherein the positive C plate has a thickness of 0.1 to 3 μm .

17. A liquid crystal panel according to claim 1, wherein the positive C plate comprises one of a hardened layer and a cured layer of a homeotropically aligned liquid crystalline composition.

18. A liquid crystal panel according to claim 1, wherein the isotropic optical element comprises a polymer film containing as a main component at least one resin selected from the group consisting of polynorbornene, a cellulose ester, an isobutylene/N-methylmaleimide copolymer, and an acrylonitrile/styrene copolymer.

19. A liquid crystal television comprising the liquid crystal panel according to claim 1.

20. A liquid crystal display apparatus comprising the liquid crystal panel according to claim 1.

* * * * *

专利名称(译)	液晶面板和液晶显示装置		
公开(公告)号	US20060114383A1	公开(公告)日	2006-06-01
申请号	US11/265202	申请日	2005-11-03
[标]申请(专利权)人(译)	日东电工株式会社		
申请(专利权)人(译)	日东电工株式会社		
当前申请(专利权)人(译)	日东电工株式会社		
[标]发明人	KOBAYASHI KENTAROU YANO SHUUJI KOISHI NAOKI		
发明人	KOBAYASHI, KENTAROU YANO, SHUUJI KOISHI, NAOKI		
IPC分类号	G02F1/1335 G02B5/30 G02F1/13363 G02F1/139		
CPC分类号	G02B5/3016 G02F1/1335 G02F1/133634 G02F1/134363 G02F1/141 G02F2001/133531 G02F2201/50		
优先权	2004344053 2004-11-29 JP 2005244847 2005-08-25 JP		
其他公开文献	US7463320		
外部链接	Espacenet USPTO		

摘要(译)

根据本发明实施例的液晶面板包括：液晶单元；第一偏振器，设置在液晶单元的一侧；第二偏振器，设置在液晶盒的另一侧；负液双轴光学元件和布置在液晶单元和第一偏振器之间的正C板；以及设置在液晶单元和第二偏振器之间的各向同性光学元件。这里，负双轴光学元件布置在第一偏振器和正C板之间。

