



US 20100225632A1

(19) **United States**

(12) **Patent Application Publication**
MA et al.

(10) **Pub. No.: US 2010/0225632 A1**

(43) **Pub. Date: Sep. 9, 2010**

(54) **LIQUID CRYSTAL DISPLAY**

(30) **Foreign Application Priority Data**

(75) Inventors: **Xinli MA**, Beijing (CN); **Heecheol KIM**, Beijing (CN); **Jai-il RYU**, Beijing (CN)

Mar. 6, 2009 (CN) 200910079710.7

Publication Classification

Correspondence Address:
LADAS & PARRY LLP
224 SOUTH MICHIGAN AVENUE, SUITE 1600
CHICAGO, IL 60604 (US)

(51) **Int. Cl.**
G02F 1/1343 (2006.01)
G09G 3/36 (2006.01)
(52) **U.S. Cl.** **345/211; 349/139**

(73) Assignee: **BEIJING BOE OPTOELECTRONICS TECHNOLOGY CO., LTD.**, Beijing (CN)

(57) **ABSTRACT**

The embodiments of the present invention disclose a liquid crystal display. The liquid crystal display comprises: a color filter substrate and an array substrate assembled together with a sealant, wherein an electrode is formed between an edge portion of an effective display region of the array substrate and the sealant, and the metal electrode is connected to a first DC power.

(21) Appl. No.: **12/718,377**

(22) Filed: **Mar. 5, 2010**

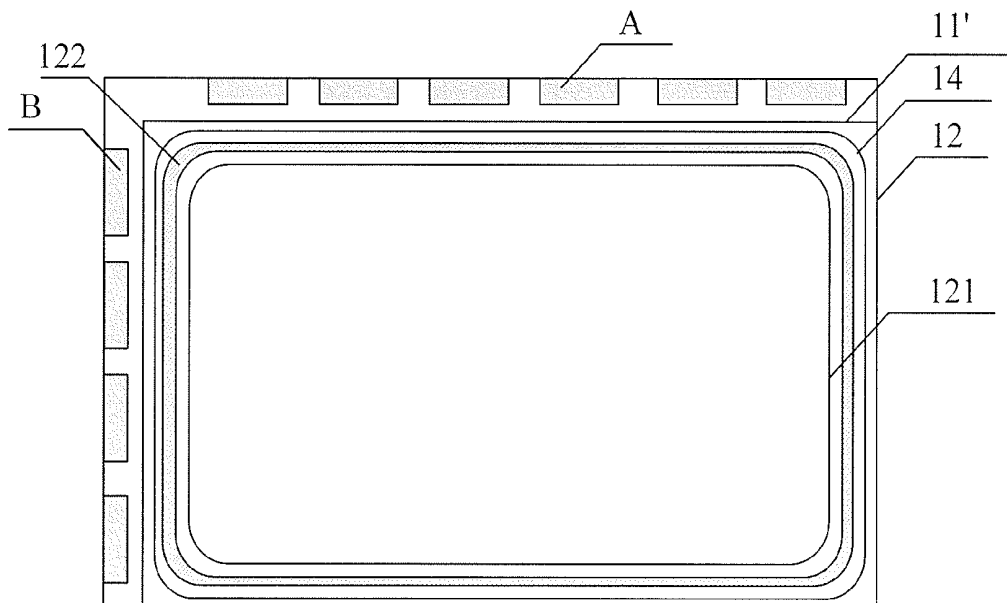

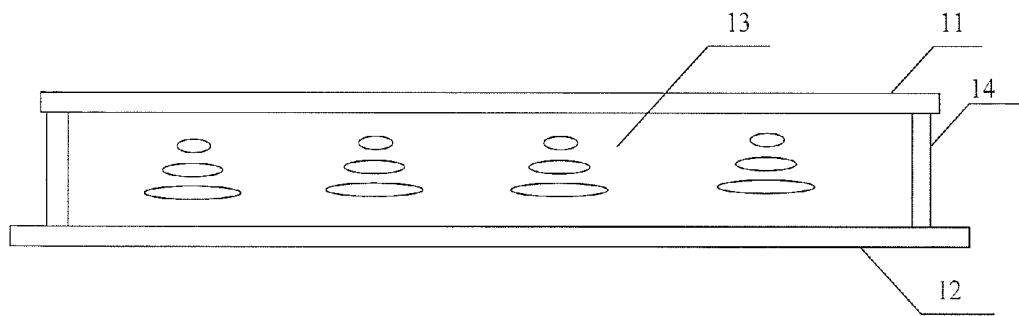

Figure 1

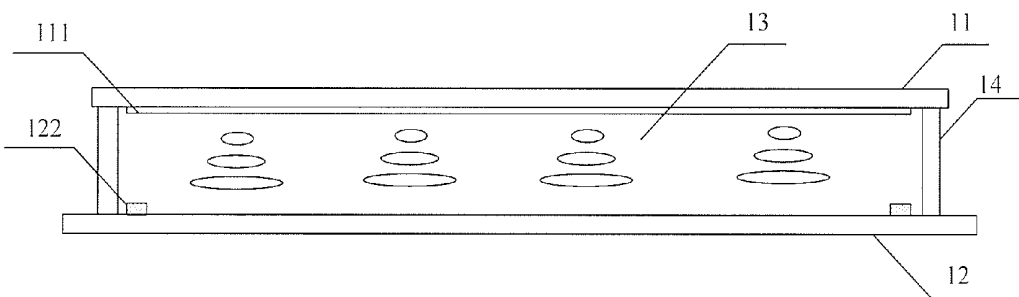

Figure 2

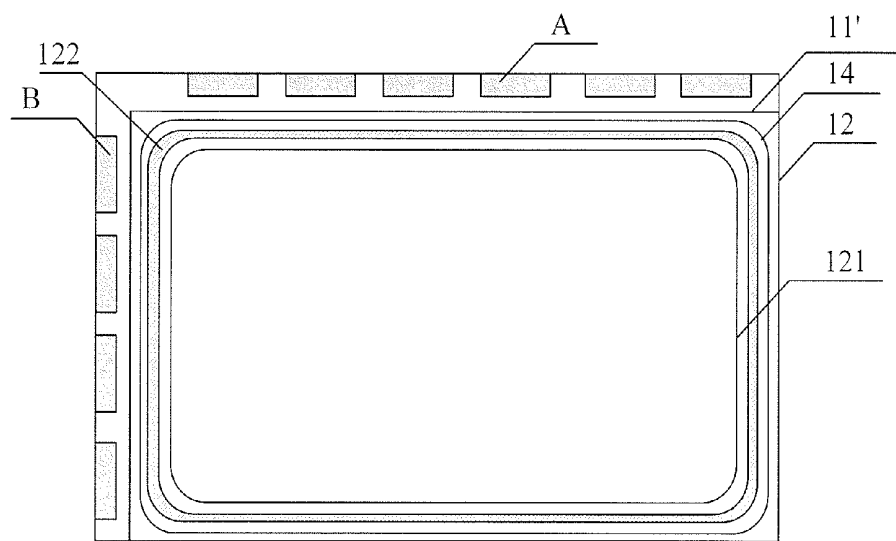

Figure 3

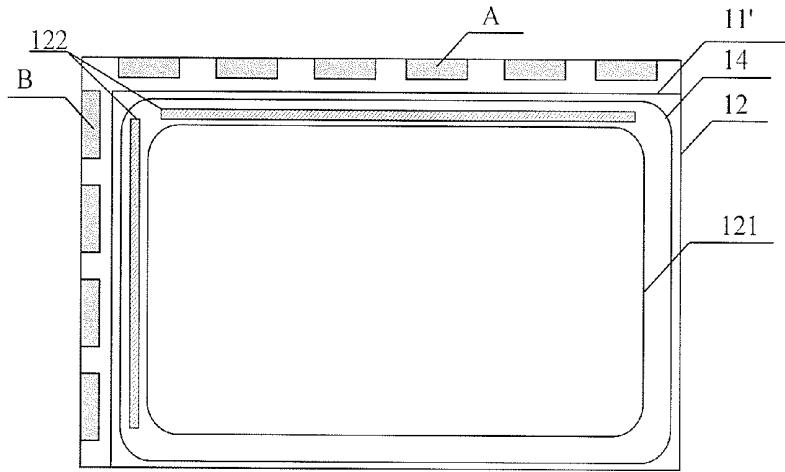

Figure 4

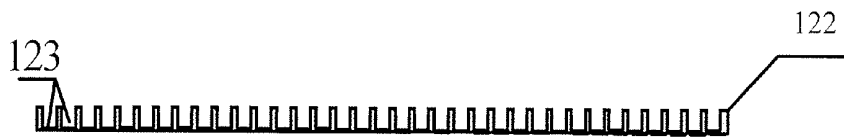

Figure 5

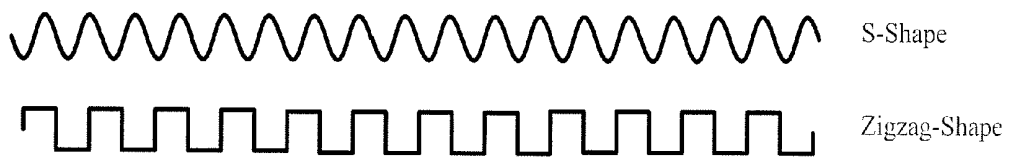

Figure 6

LIQUID CRYSTAL DISPLAY

BACKGROUND

[0001] The present invention relates to a liquid crystal display (LCD).

[0002] Liquid crystal displays (LCDs) have a lot of advantages. For example, compared with a cathode ray tube, liquid crystal displays are thinner and have lower energy consumption. Therefore, liquid crystal displays have substituted CRT displays in many fields.

[0003] As shown in FIG. 1, a display panel of an existing thin film transistor-liquid crystal display (TFT-LCD) includes an array substrate 12, a color filter substrate 11, and a liquid crystal layer 13 interposed between the array substrate 12 and the color filter substrate 11. The peripheries of the array substrate 12 and the color filter substrate 11 are sealed with a sealant 14. FIG. 1 does not show all configurations of the liquid crystal display for the sake of brevity.

[0004] In an existing process of manufacturing a liquid crystal display, after the processes of forming the array substrate and the color filter substrate, it requires to perform a cell assembling process, i.e., a process for assembling the array substrate and the color filter substrate together. The cell assembling process includes steps of: applying an alignment film on the array substrate and the color filter substrate, respectively; curing the alignment film and rubbing the alignment film; then, drop-filling liquid crystal, applying the sealant; assembling the array substrate and the color filter substrate together and curing the sealant; and last, sectioning the assembled array substrate and color substrate so as to form separate liquid crystal cells.

[0005] During the above described cell assembling process, if the sealant comes into contact with the liquid crystal before completely cured, the liquid crystal will be polluted. The display quality of the polluted liquid crystal display panel may deteriorate dramatically. Image sticking, especially, line image sticking is liable to occur, especially around the effective display area of the liquid crystal display panel, due to the impurity ions in the sealant, the temperature, and other factors.

[0006] Various measures have been adopted to cure the sealant before it comes into contact with the liquid crystal so as to avoid the pollution to the liquid crystal due to the contact between the sealant and the liquid crystal. After the substrates are assembled, there is a short interval from the time when the liquid crystal starts to disperse to the time when the liquid crystal comes into contact with the sealant. In general, the sealant is pre-cured with UV in the short interval to prevent pollution to the liquid crystal by the impurity ions in the sealant when the sealant is in contact with the liquid crystal. However, although the sealant is pre-cured with UV, some impurity ions in the sealant may still enter into the effective display region in the liquid crystal display panel, which deteriorates the display quality of the finished liquid crystal display panel.

SUMMARY

[0007] An embodiment of the present invention provides a liquid crystal display, comprising: a color filter substrate and an array substrate assembled together with a sealant, wherein an electrode is formed between an edge portion of an effective display region of the array substrate and the sealant, and the electrode is connected to a first DC power.

[0008] In the liquid crystal display according to the present invention, the electrode is formed between the edge portion of the effective display region of the array substrate and the sealant, and the electrode is connected to the first DC power, so that an electric field and thus a voltage difference are formed between the electrode and the common electrode after the electric power is supplied to the liquid crystal display. Thus, the impurity ions in the sealant that enter into the electric field regions can be attracted by the electrode, which prevents the pollution of the liquid crystal caused by the impurity ions.

BRIEF DESCRIPTION OF THE DRAWINGS

[0009] It is apparent that the accompanying drawings described hereinafter only are some embodiments of the present invention, those skilled in the art can obtain other drawings based on these without any labor of creativity.

[0010] FIG. 1 is a schematic view of a structure of a liquid crystal display;

[0011] FIG. 2 is a schematic view of a liquid crystal display according to an embodiment of the present invention;

[0012] FIG. 3 is a schematic view of an array substrate in the liquid crystal display shown in FIG. 2;

[0013] FIG. 4 is a schematic view of another arrangement of an electrode according to an embodiment of the present invention;

[0014] FIG. 5 is a schematic view of a still another arrangement of the electrode according to an embodiment of the present invention; and

[0015] FIG. 6 is a schematic view of the electrode in S-shape, and zigzag shape according to an embodiment of the present invention.

DETAILED DESCRIPTION OF THE PREFERRED EMBODIMENTS

[0016] Hereinafter, a liquid crystal display according to embodiments of the present invention will be described in detail with reference to the accompanying drawings.

[0017] It is clear that the described embodiments are only a part of embodiments of the present invention, not all embodiments of the present invention. Based on the embodiments of the present invention, those skilled in the art can obtain all other embodiments within the scope of the present invention without any labor of creativity.

[0018] As shown in FIG. 2, a liquid crystal display of the present invention comprises a color filter substrate 11 and an array substrate 12, which are assembled together with a sealant 14, and a metal electrode 122 formed between an edge portion of an effective display region of the array substrate 12 and the sealant 14. The metal electrode 122 is connected to a first DC power (not shown in drawings). A common electrode 111 is disposed on the color filter substrate 11 above the metal electrode 122.

[0019] To explicitly show the position of the metal electrode 122, FIG. 3 shows the basic structure of the array substrate 12 in the liquid crystal display shown in FIG. 2. The shape 11' in FIG. 3 shows the projection of the color filter substrate 11 on the array substrate 12. The reference symbol A, B denote the input leads of a data scanning line and a gate scanning line, respectively. The metal electrode 122 is located between the display region 121 and the sealant 14 on the array substrate 12.

[0020] The metal electrode **122** is connected to the first DC power, such as, a DC drive power AVDD or the gate scanning signal Von/Voff in the liquid crystal display. When the electric power is applied on the liquid crystal display, if the metal electrode **122** is connected to the gate scanning signal Von/Voff, the voltage of metal electrode **122** is at high level Von while the gate scanning signal is at high level Von, and the voltage of metal electrode **122** is at low level Voff while the gate scanning signal is at low level Voff. In general, Von is larger than 20V, Voff is a negative voltage, and the voltage of the common electrode **111** on the color filter substrate **11** may be 5V, thus the voltage difference between the metal electrode **122** and the common electrode **111** may be approximately 5V~35V.

[0021] The voltage difference between the metal electrode **122** and the common electrode **111** located opposite to the metal electrode **122** produces an electric field. Thus, the impurity ions in the sealant **14** that enter into the area in which the electric field is formed may attach to the metal electrode **122** or the common electrode **111** on the color filter substrate **11** due to the electric field, which prevents the impurity ions in the sealant **14** from entering into the display region **121** of the liquid crystal display and thus polluting the liquid crystal molecules. The above design reduces the line image sticking of the liquid crystal display due to the impurity, and thus improves the display quality of the liquid crystal display.

[0022] To realize the embodiment in a better way, the area of the common electrode **111** on the color filter substrate **11** is preferable larger than that in a conventional liquid crystal display. That is, as shown in FIG. 3, the edge portion of the common electrode **111** is aligned with the edge portion of the metal electrode **122** neighboring the sealant **14**, so that a strong electric field is formed in the area where the common electrode **111** is disposed opposite to the metal electrode **122**, which is more favorable to attract the impurity ions with the metal electrode **122** and the common electrode **111**.

[0023] In the embodiment of the present invention, the metal electrode **122** may be disposed along (e.g., parallel with) any one side or any sides of the effective display region **121**. As shown in FIG. 4, the metal electrode **122** may be disposed on one side of the display region **121** neighboring the input lead A of the data scanning line, and can also be disposed on one side of the display region **121** neighboring the input lead B of the gate scanning line. Further, the metal electrode **122** can also be disposed on the other side of the display region **121** or on both sides of the display region **121** with respect to the input lead A of the data scanning line and the input lead B of the gate scanning line. These metal electrodes **122** may be connected to each other or set apart from each other. These metal electrodes **122** also may be disposed surrounding the edge portion of the display region **121**, as shown in FIG. 3.

[0024] The metal electrodes **122** can be replaced with electrodes that made of non-metal conductive material. Thus, in the above embodiments, the electrode may be made of one material or a combination of two or more selected from a group consisting of ITO, molybdenum, aluminum, and copper. The pixel electrode of the array substrate or the common electrode of the color filter substrate may be made of a metal material of ITO, and the source electrode, drain electrode, or gate electrode in the array circuit of the array substrate may be made of the metal material, such as molybdenum, aluminum, and copper. Therefore, it is convenient to obtain the material for the metal electrode **122** according to the present invention.

[0025] A distance between the metal electrode **122** and the sealant **14** may be 0.3 mm~4 mm. In particular, the distance between the metal electrode **122** and the sealant **14** depends on the size of the liquid crystal display panel and the size of the area between the display region **121** in the array substrate **12** and the sealant **14**, and should be determined according to actual needs.

[0026] Since the metal electrode **122** is disposed on the array substrate **12**, interlayer capacitances may be produced between the metal electrode **122** and other metal layers on the array substrate **12**, which induces RC delay phenomenon. To resolve this problem, portions of the metal electrode **122** located opposite to the respective data scanning lines or gate scanning lines on the array substrate **12** are designed to be narrower than other portions of the metal electrode **122**. For example, FIG. 5 shows the shape of the metal electrode **122** adjacent to the lead A of the data scanning line shown in the upper portion of FIG. 4. Grooves **123** are formed on the side of the metal electrode **122** facing the data scanning line, so that the area of the metal electrode **122** facing the data scanning line can be reduced, which decreases the interlayer capacitance.

[0027] In addition, the shape of the metal electrode **122** may be one or a combination of two or more selected from a group consisting of stripe shape, S-shape, zigzag-shape, and other shapes. Referring to FIG. 6, the metal electrode may be S-shaped or zigzag-shaped. Since the space between the display region **121** and the sealant is limited, the metal electrode is relatively small in general. The electric field area capable of preventing the impurity ions of the sealant from entering into the liquid crystal layer can be determined according to actual needs, and the shape and size of the metal electrode can be determined thereupon.

[0028] In the above embodiments, the electric field is formed between the metal electrode **122** and the common electrode **111** on the color filter substrate **11**. The present invention, however, is not limited thereto. An auxiliary electrode corresponding to the metal electrode **122** can be disposed on the color filter electrode **11**, and a second DC power which is different from the first DC power is applied on the auxiliary electrode, which also implements the present invention. The auxiliary electrode also can be made of the same material as the metal electrode **122** and can have the shape as the metal electrode **122**. The second DC power can be provided by the DC drive power in the driving circuit within the liquid crystal display, as long as the voltage or polarity of the second DC power differs from that of the first DC power. To attract as many impurity ions as possible to the metal electrode or the auxiliary electrode, the voltage difference between the first and second DC power shall not be too small, it can be, e.g., 5V~35V (referring to the above embodiments). If the shape of the auxiliary electrode is the same as that of the metal electrode **122** and the auxiliary electrode is disposed opposite to the metal electrode **122**, the electric field can be kept within the area where the auxiliary electrode is disposed opposite to the metal electrode, so that the electric field can not influence other portions of the liquid crystal display panel.

[0029] In the liquid crystal display according to the present invention, the metal electrode is formed between the edge portion of the display region of the array substrate and the sealant, and the metal electrode is connected to the first DC power, so that an electric field is formed due to the voltage difference between the metal electrode and the common electrode. Thus, the impurity ions in the sealant that enter into the

electric field regions can be attached on the metal electrode or on the common electrode, which prevents the pollution to the liquid crystal caused by the impurity ions. In addition, if an auxiliary electrode is disposed on the color filter substrate, and a second DC power that is different from the first DC power may be supplied to the auxiliary electrode, the similar effect can also be achieved, that is, the metal electrode and the auxiliary electrode can attract and attach the impurity ions in the sealant that enter into the electric field region, which prevents the pollution to the liquid crystal caused by the impurity ions, reduces the line image sticking on the liquid crystal display, and improves the display quality of the liquid crystal display.

[0030] The above description only describes detailed embodiments of the present invention, it is not a limitation of the scope of the present invention. Accordingly, it should be understood that many modifications or alternation which can be made easily by those of ordinary skill in the art within the disclosure of the present invention, will fall within the scope of the present invention as defined by the appended claims.

What is claimed is:

1. A liquid crystal display, comprising:

a color filter substrate and an array substrate assembled together with a sealant,

wherein an electrode is formed between an edge portion of an effective display region of the array substrate and the sealant, and the electrode is connected to a first DC power.

2. The liquid crystal display according to claim 1, wherein the electrode is disposed along any one side or a plurality of sides of the effective display region.

3. The liquid crystal display according to claim 2, wherein the shape of the electrode is selected from a group consisting of stripe shape, S-shape, zigzag-shape, and any combination thereof.

4. The liquid crystal display according to claim 1, wherein the electrode is disposed surrounding the edge portion of the effective display region.

5. The liquid crystal display according to claim 4, wherein the shape of the electrode is selected from a group consisting of stripe shape, S-shape, zigzag-shape, and any combination thereof.

6. The liquid crystal display according to claim 1, wherein the electrode is made of a material selected from a group consisting of ITO, molybdenum, aluminum, copper, and any combination thereof.

7. The liquid crystal display according to claim 6, wherein the shape of the electrode is selected from a group consisting of stripe shape, S-shape, zigzag-shape, and any combination thereof.

8. The liquid crystal display according to claim 1, wherein an edge portion of a common electrode on the color filter substrate is aligned with an edge portion of the electrode neighboring the sealant.

9. The liquid crystal display according to claim 8, wherein the shape of the electrode is selected from a group consisting of stripe shape, S-shape, zigzag-shape, and any combination thereof.

10. The liquid crystal display according to claim 1, wherein an auxiliary electrode is disposed on the color filter substrate and opposite to the electrode, and is connected to a second DC power.

11. The liquid crystal display according to claim 10, wherein

the shape of the electrode is selected from a group consisting of stripe shape, S-shape, zigzag-shape, and any combination thereof.

12. The liquid crystal display according to claim 1, wherein portions of the electrode located opposite to respective data scanning lines or gate scanning lines on the array substrate are narrower than other portions of the electrode.

13. The liquid crystal display according to claim 12, wherein

the shape of the electrode is selected from a group consisting of stripe shape, S-shape, zigzag-shape, and any combination thereof.

14. The liquid crystal display according to claim 1, wherein the first DC power is a DC drive power within the liquid crystal display.

15. The liquid crystal display according to claim 14, wherein

the shape of the electrode is selected from a group consisting of stripe shape, S-shape, zigzag-shape, and any combination thereof.

16. The liquid crystal display according to claim 10, wherein the second DC power is a DC drive power within the liquid crystal display.

17. The liquid crystal display according to claim 16, wherein

the shape of the electrode is selected from a group consisting of stripe shape, S-shape, zigzag-shape, and any combination thereof.

18. The liquid crystal display according to claim 1, wherein a distance between the electrode and the sealant is 0.3 mm~4 mm.

19. The liquid crystal display according to claim 18, wherein

the shape of the electrode is selected from a group consisting of stripe shape, S-shape, zigzag-shape, and any combination thereof.

20. The liquid crystal display according to claim 1, wherein the shape of the electrode is selected from a group consisting of stripe shape, S-shape, zigzag-shape, and any combination thereof.

* * * * *

专利名称(译)	液晶显示器		
公开(公告)号	US20100225632A1	公开(公告)日	2010-09-09
申请号	US12/718377	申请日	2010-03-05
[标]申请(专利权)人(译)	北京京东方光电科技有限公司		
申请(专利权)人(译)	北京京东方光电科技有限公司.		
当前申请(专利权)人(译)	北京京东方光电科技有限公司.		
[标]发明人	MA XINLI KIM HEECHEOL RYU JAI IL		
发明人	MA, XINLI KIM, HEECHEOL RYU, JAI-IL		
IPC分类号	G02F1/1343 G09G3/36		
CPC分类号	G02F1/1339		
优先权	200910079710.7 2009-03-06 CN		
其他公开文献	US9360711		
外部链接	Espacenet USPTO		

摘要(译)

本发明的实施例公开了一种液晶显示器。液晶显示器包括：滤色器基板和与密封剂组装在一起的阵列基板，其中，在阵列基板的有效显示区域的边缘部分与密封剂之间形成电极，并且金属电极连接到第一直流电源。

