



(19) **United States**

(12) **Patent Application Publication** (10) **Pub. No.: US 2007/0002253 A1**

Kim et al.

(43) **Pub. Date:**

Jan. 4, 2007

(54) **LIQUID CRYSTAL DISPLAY**

Publication Classification

(75) Inventors: **Hyun-Wuk Kim**, Yongin-si (KR);
Kyoung-Ju Shin, Yongin-si (KR);
Hak-Sun Chang, Yongin-si (KR);
Seung-Hoo Yoo, Seongnam-si (KR);
Hee-Wook Do, Suwon-si (KR);
Yoon-Sung Um, Yongin-si (KR);
Mee-Hye Jung, Hwaseong-si (KR)

(51) **Int. Cl.**
G02F 1/1343 (2006.01)
(52) **U.S. Cl.** **349/144**

(57) **ABSTRACT**

A liquid crystal display includes a substrate, a pixel electrode disposed on the substrate and including a first subpixel electrode and a second subpixel electrode, and a common electrode facing the pixel electrode. The first subpixel electrode comprises a first edge, a second edge disposed opposite the first edge, and two first oblique edges substantially parallel to each other, the first oblique edges making an oblique angle with the first edge and the second edge and meeting the first edge. The second subpixel electrode comprises a first edge, a second edge disposed opposite the first edge, and two first oblique edges substantially parallel to or substantially perpendicular to the first oblique edges of the first subpixel electrode, the first oblique edges of the second subpixel electrode meeting the first edge of the second subpixel electrode. The first edge of the first subpixel electrode is adjacent to the first edge of the second subpixel electrode, and a length of the first edge of the first subpixel electrode is different from a length of the first edge of the second subpixel electrode. The first oblique edges of the first subpixel electrode are offset from the first oblique edges of the second subpixel electrode.

Correspondence Address:
F. CHAU & ASSOCIATES, LLC
130 WOODBURY ROAD
WOODBURY, NY 11797 (US)

(73) Assignee: **Samsung Electronics Co., Ltd.**

(21) Appl. No.: **11/477,644**

(22) Filed: **Jun. 29, 2006**

(30) **Foreign Application Priority Data**

Jul. 1, 2005 (KR) 10-2005-0059157
Aug. 9, 2005 (KR) 10-2005-0072794

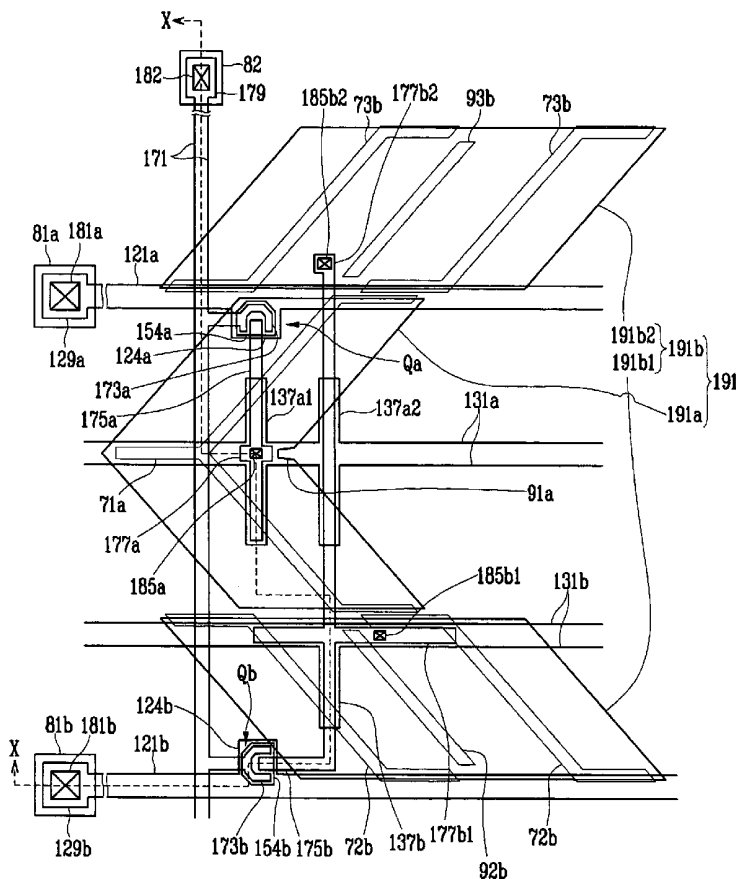

FIG. 1

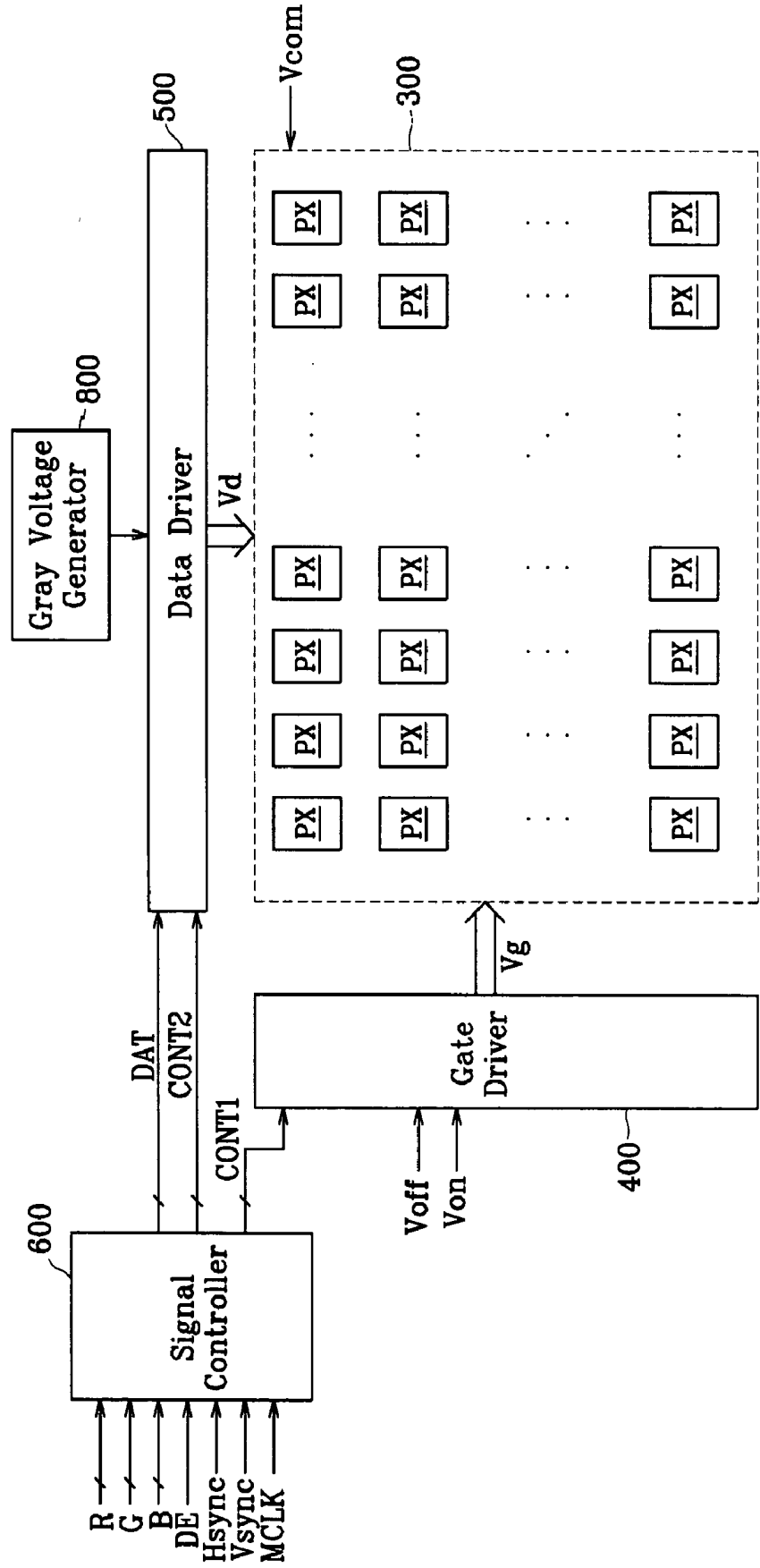

FIG. 2

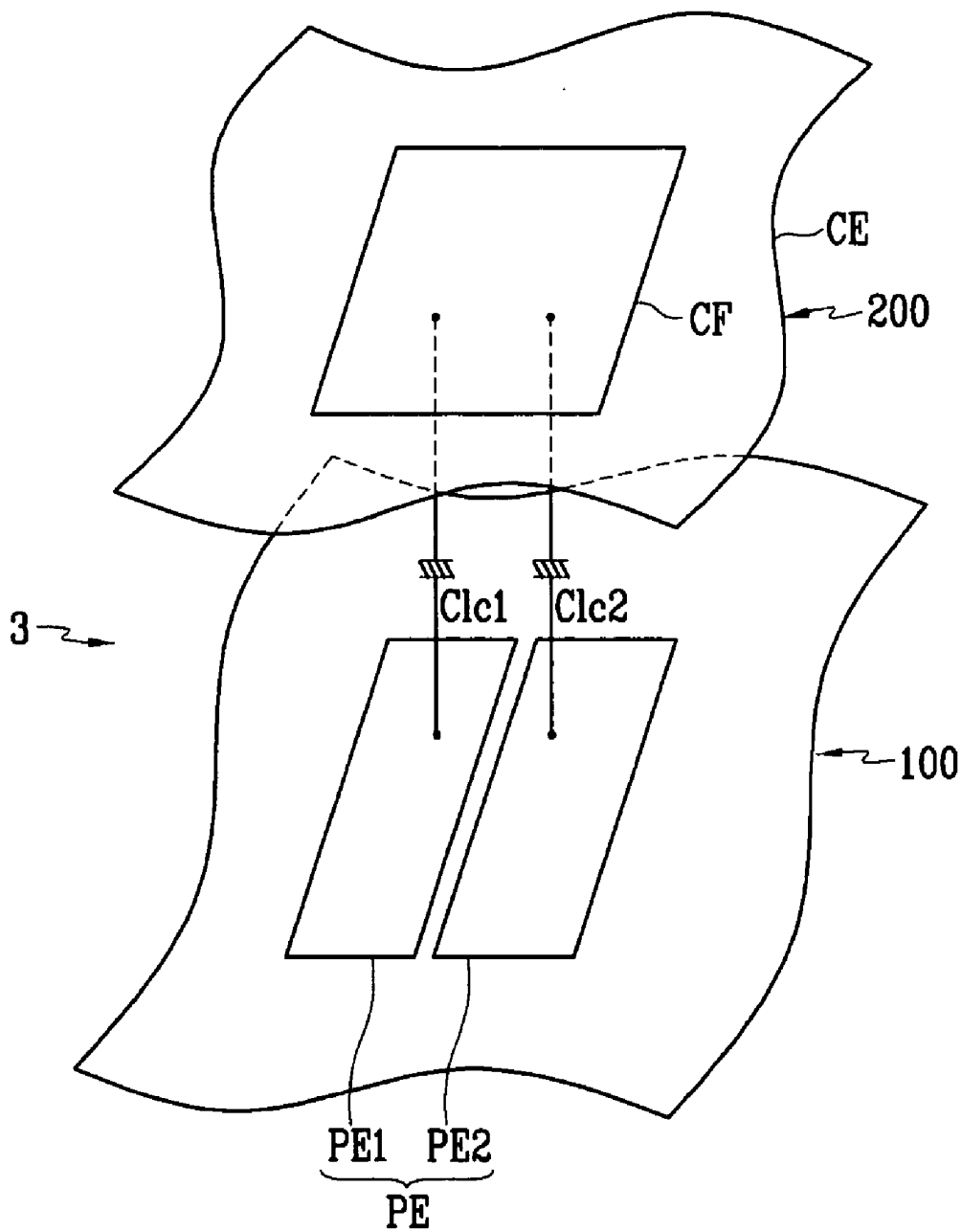

FIG. 3

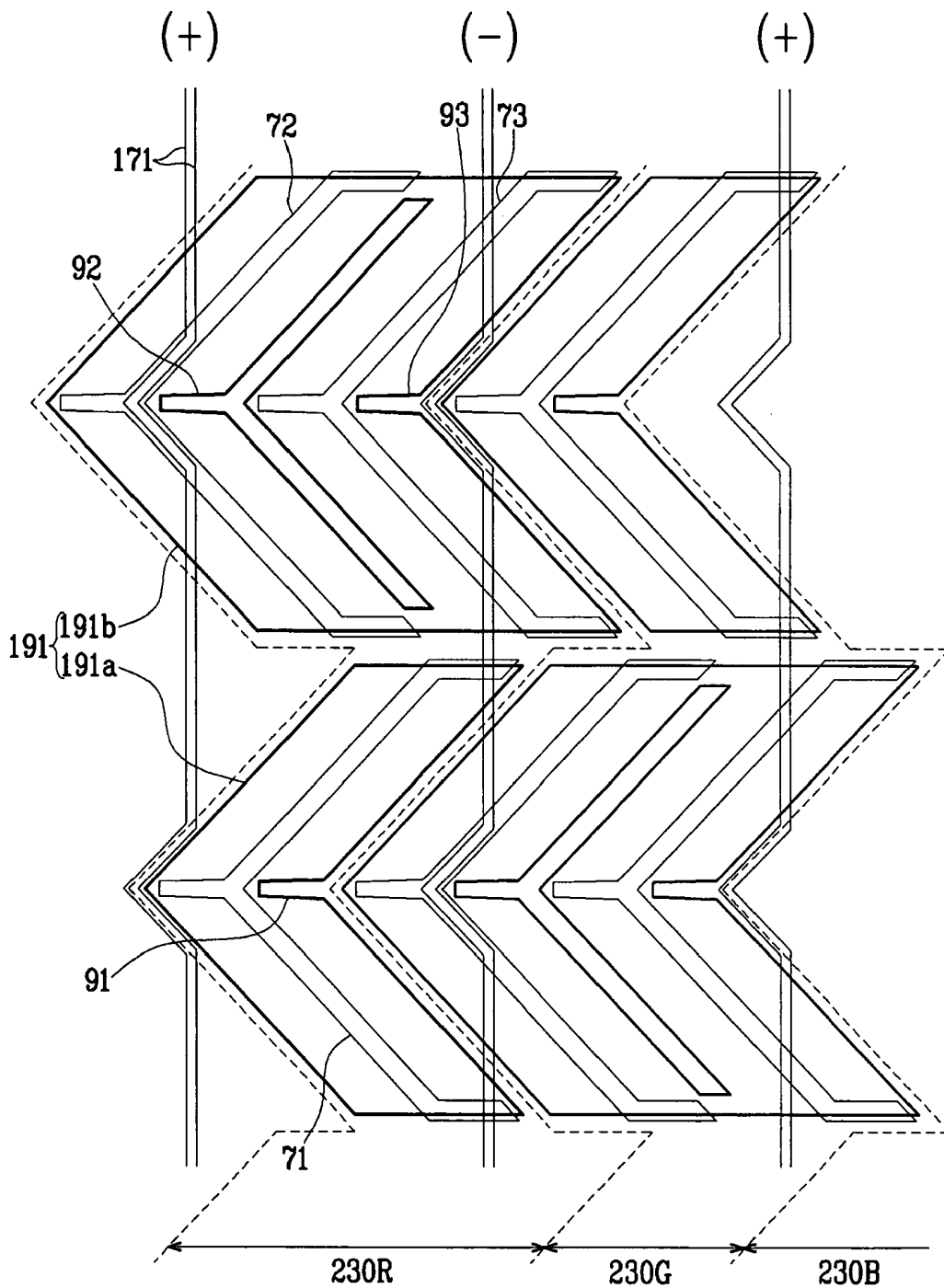

FIG. 4

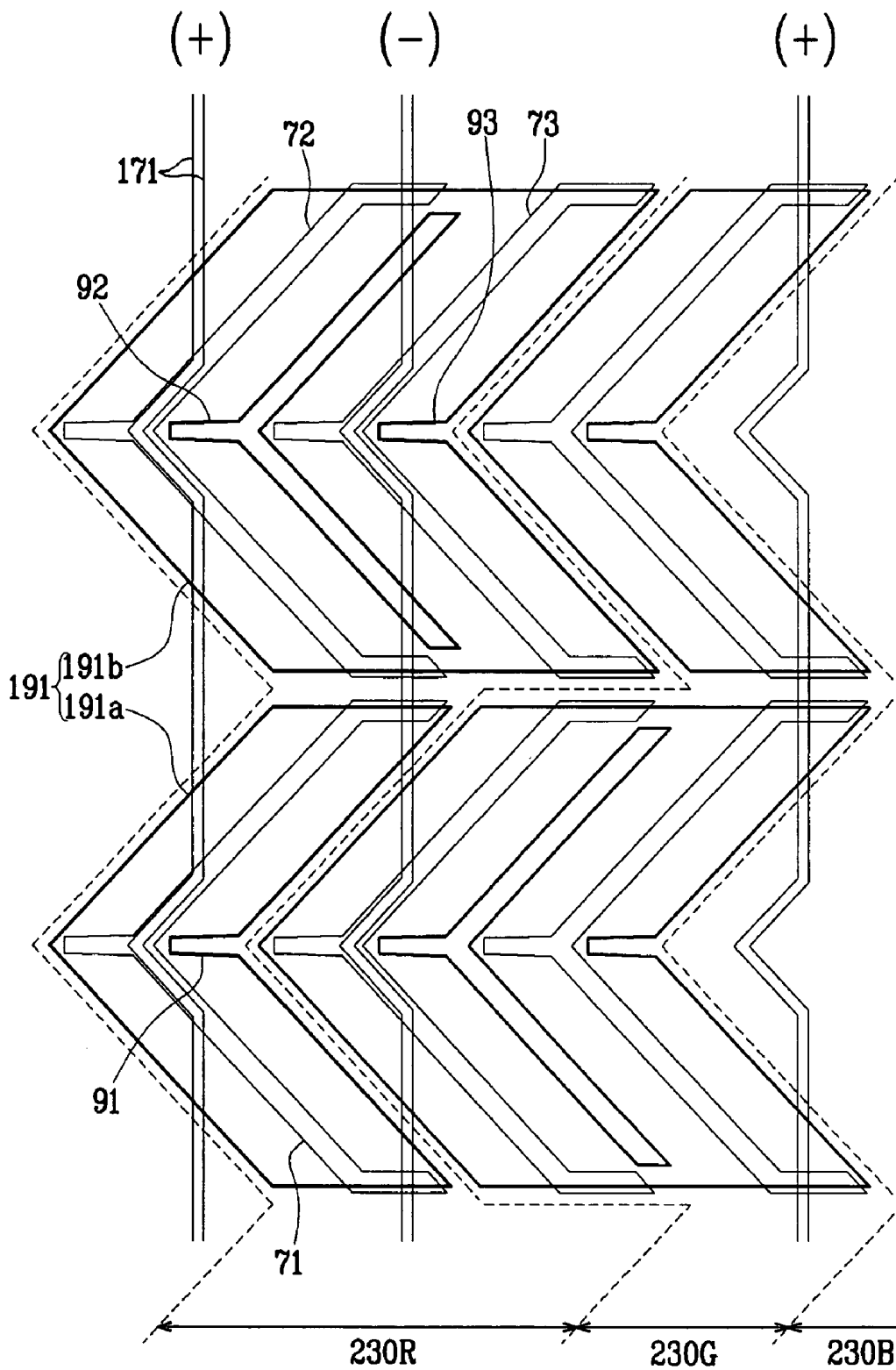

FIG. 5

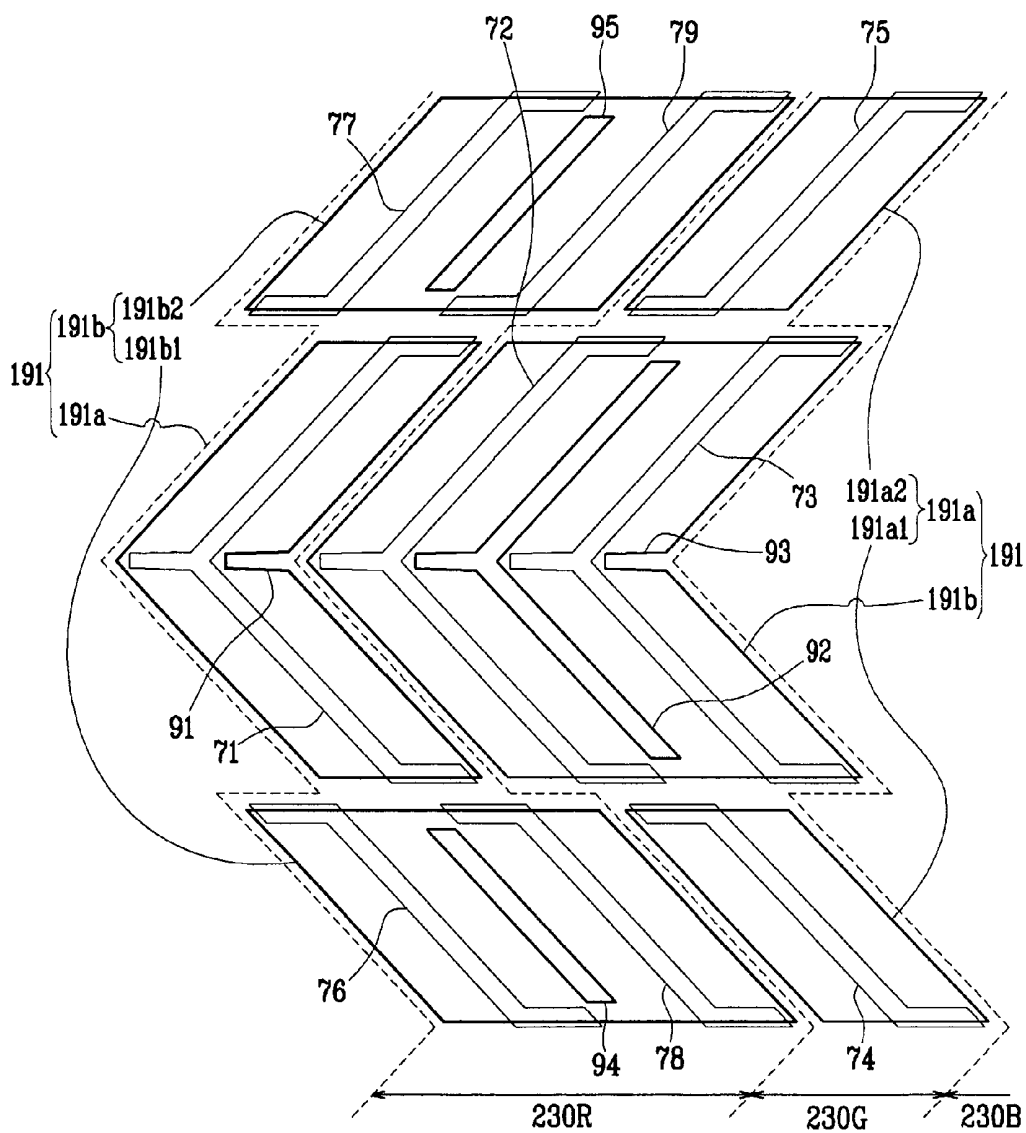

FIG. 6

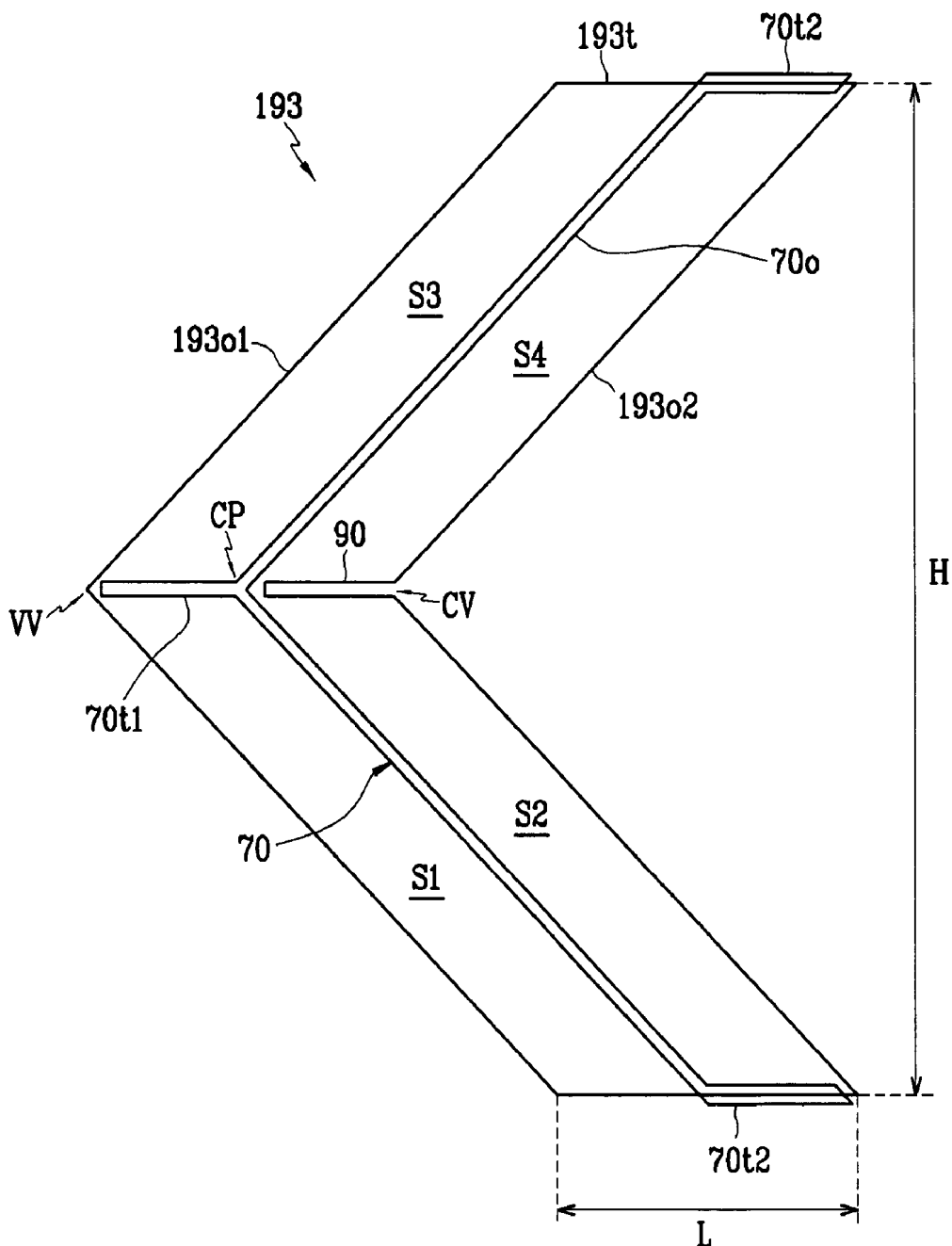

FIG. 7A

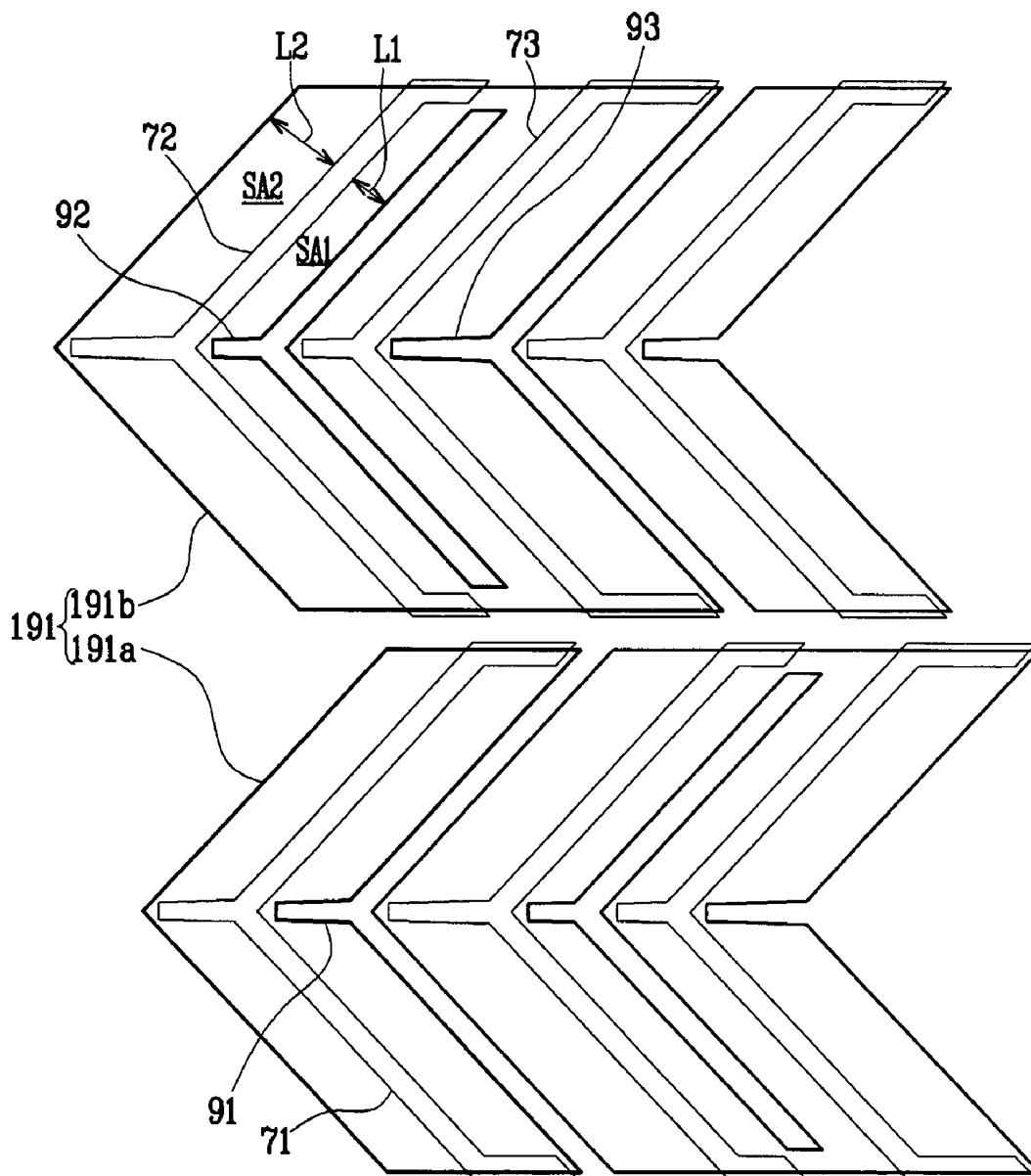

FIG. 8

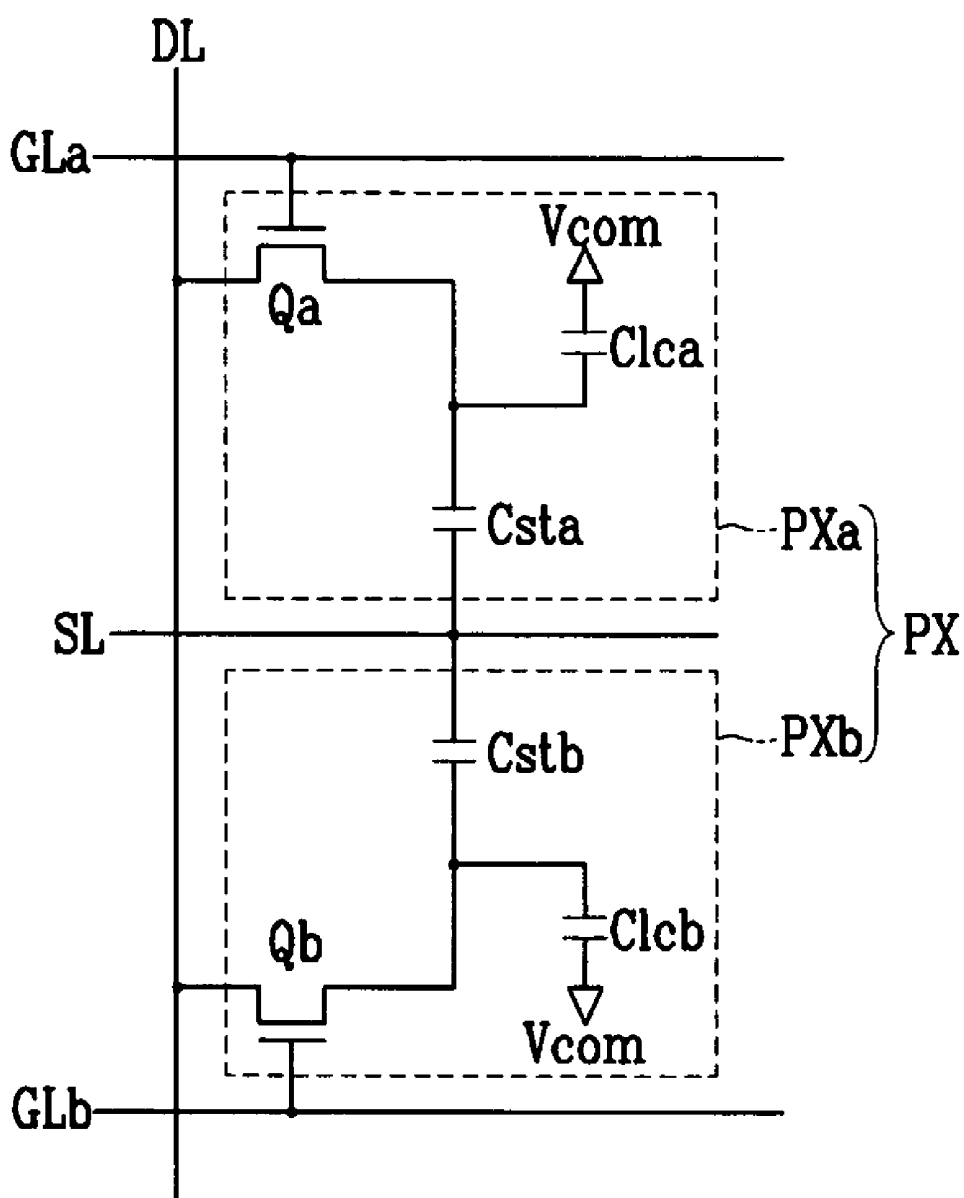

FIG. 10

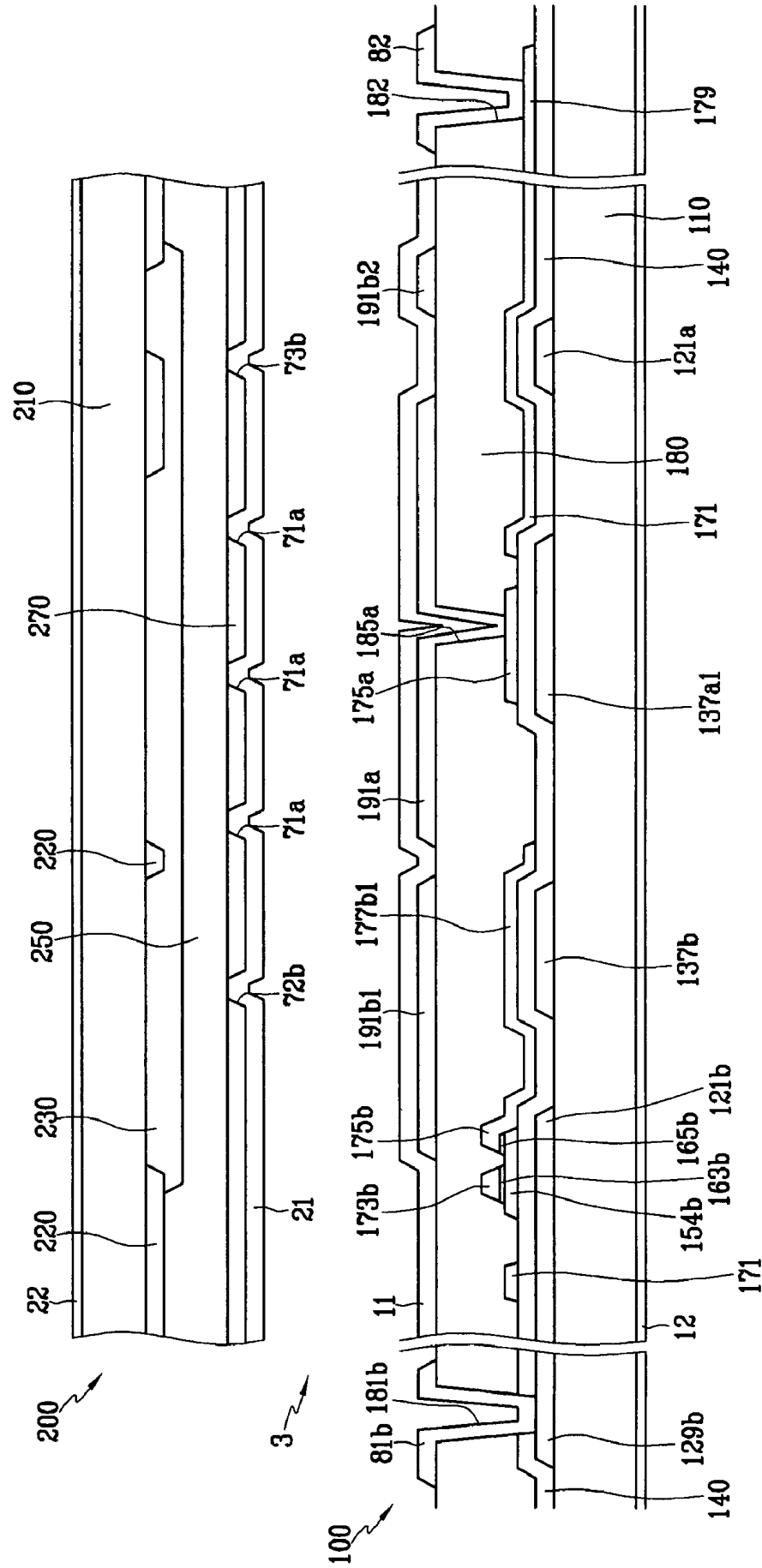

FIG. 11

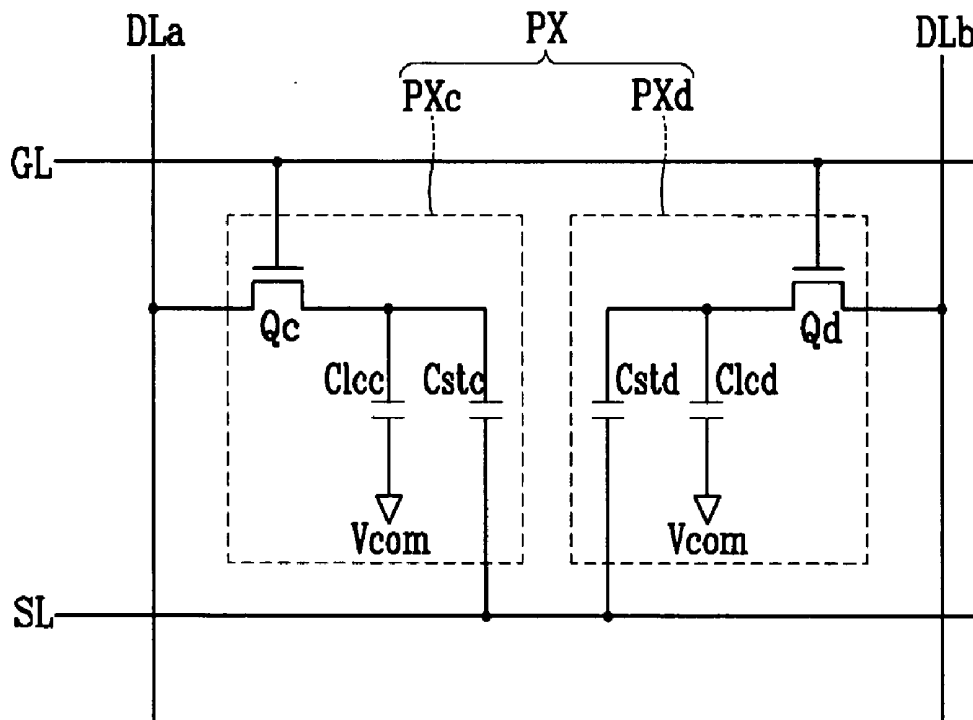

FIG. 12

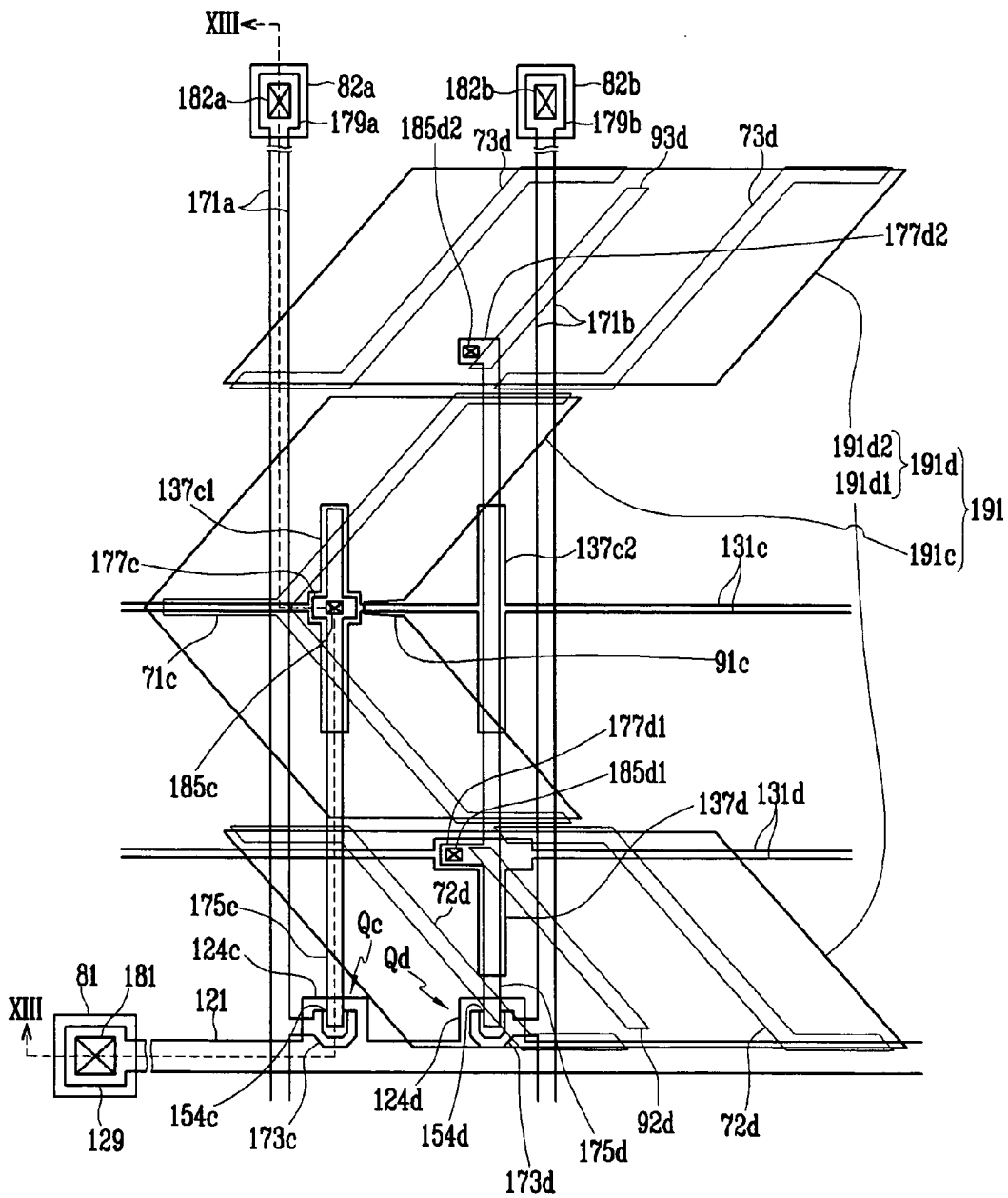

FIG. 14

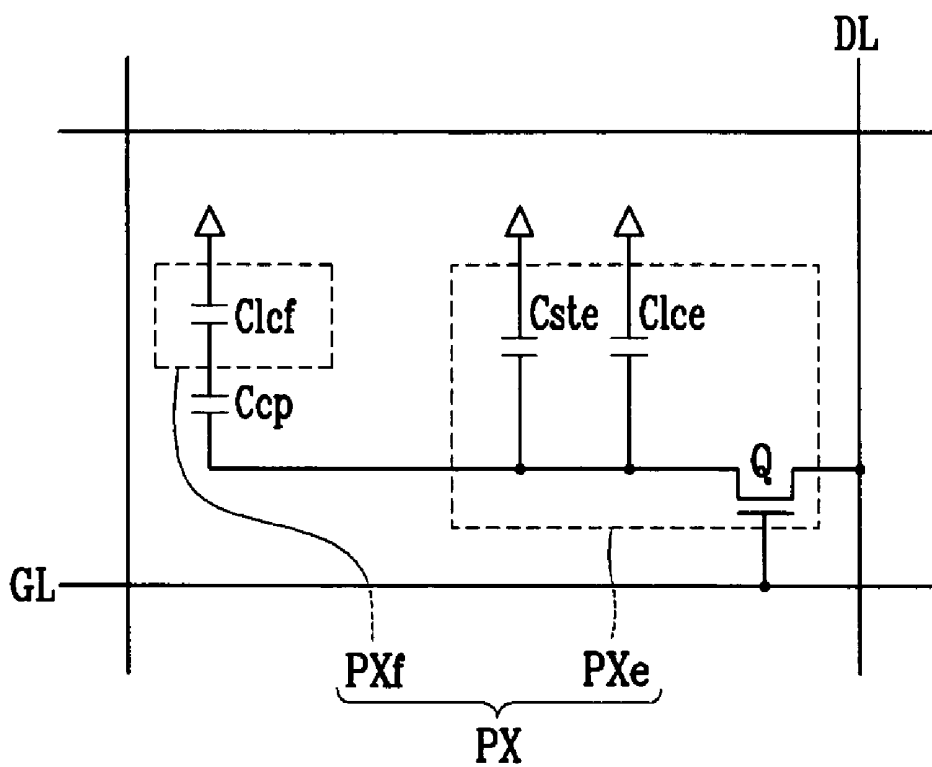

FIG. 16

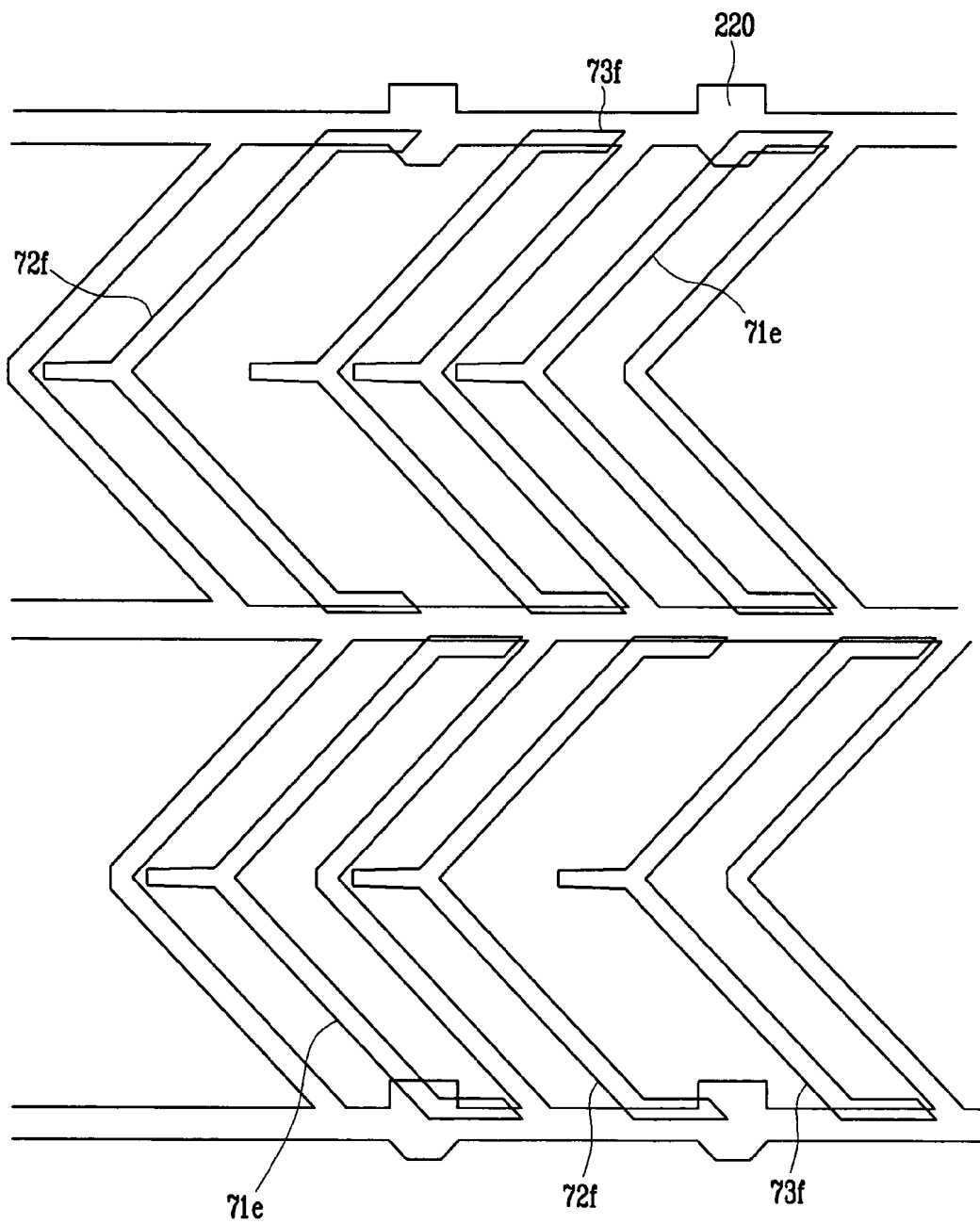

FIG. 17

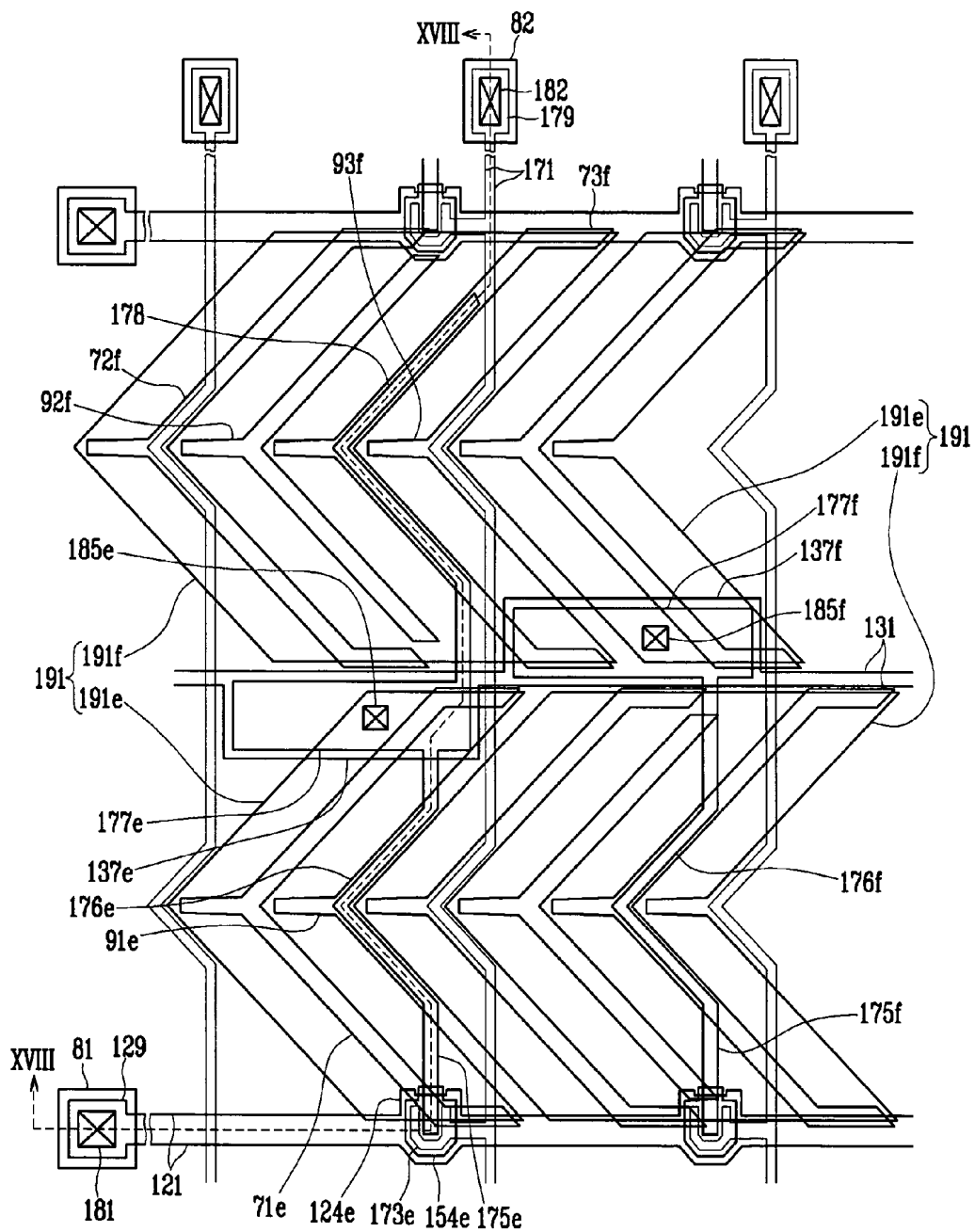

FIG. 18

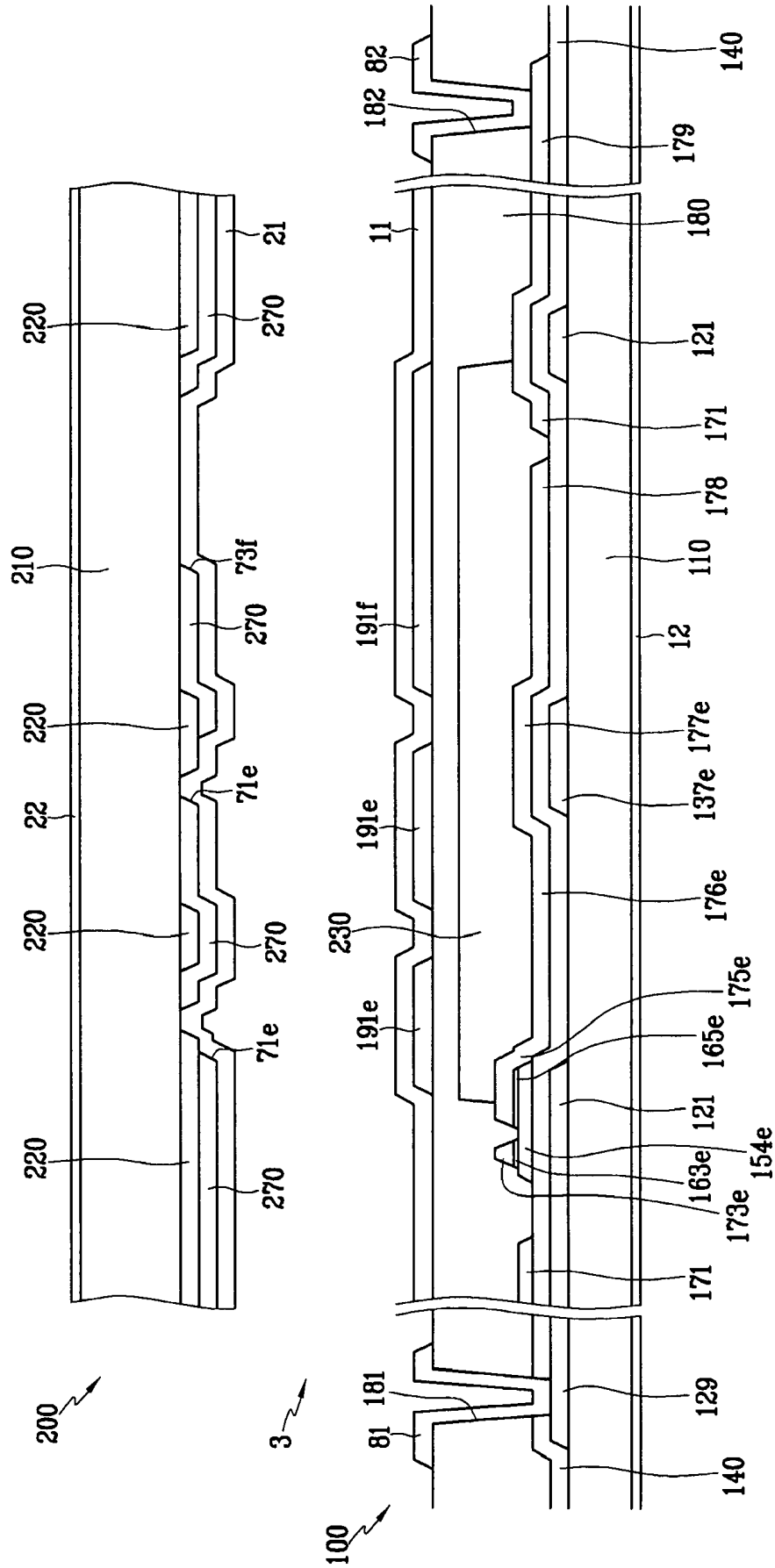

FIG. 19

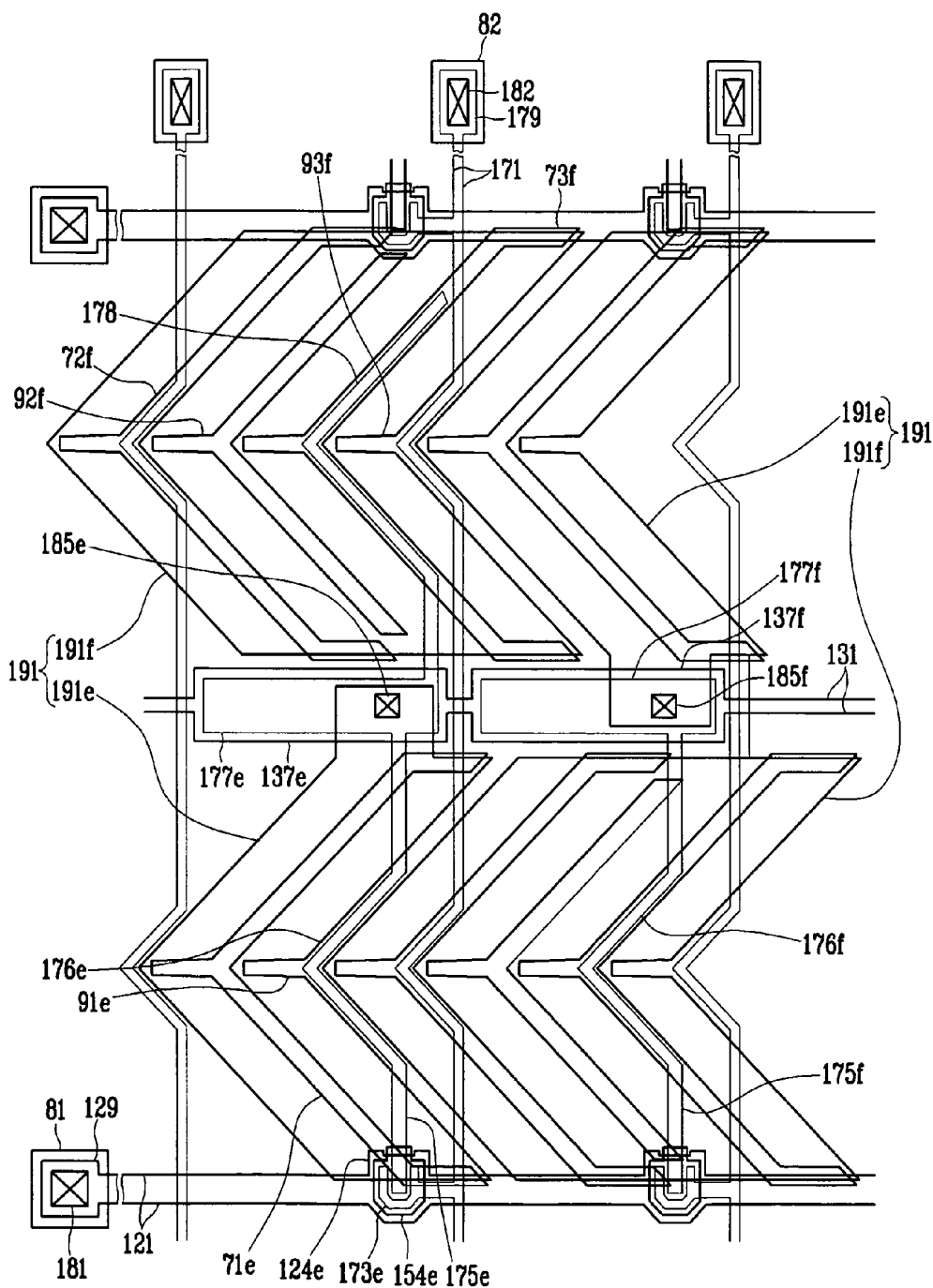

FIG. 20

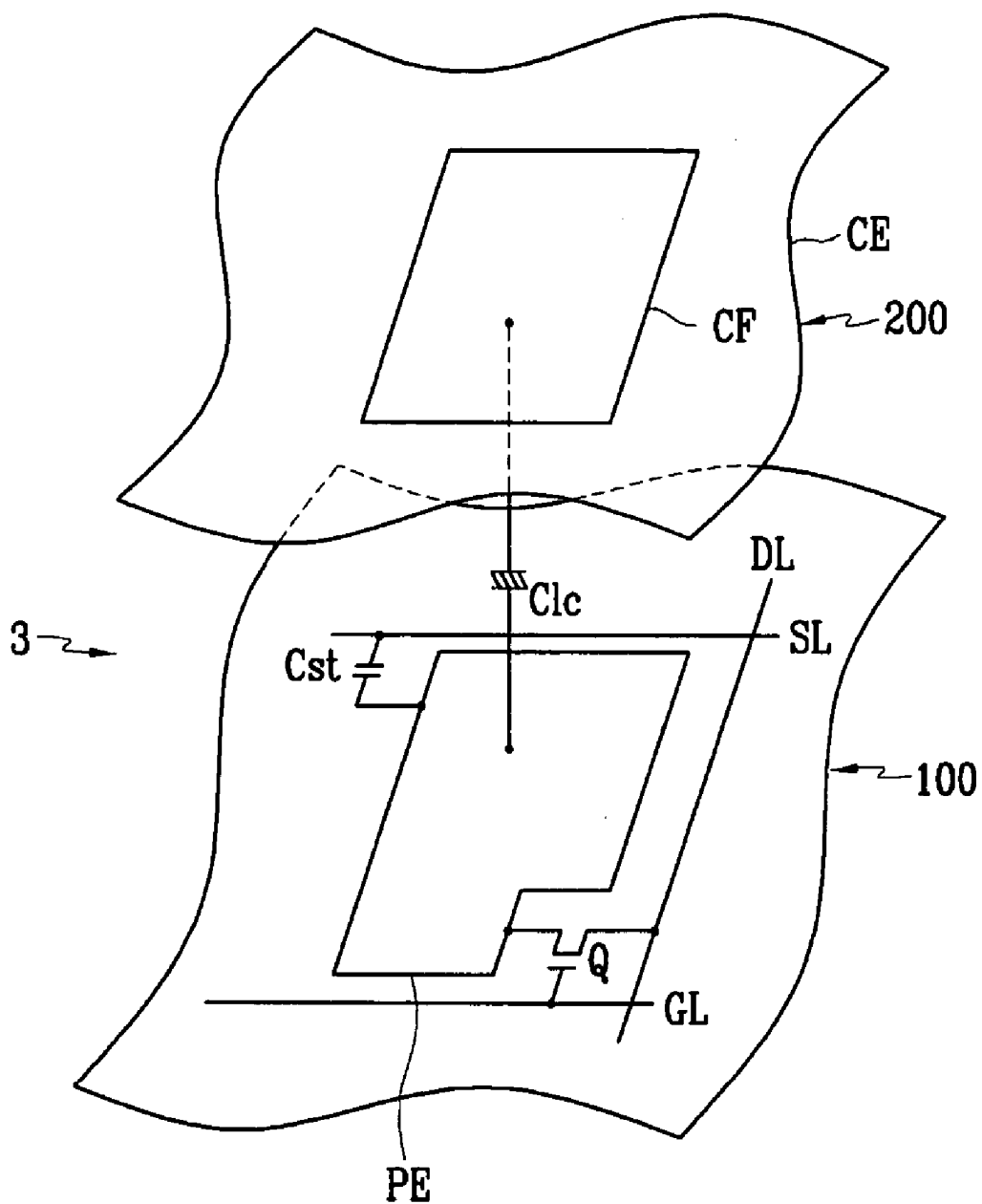
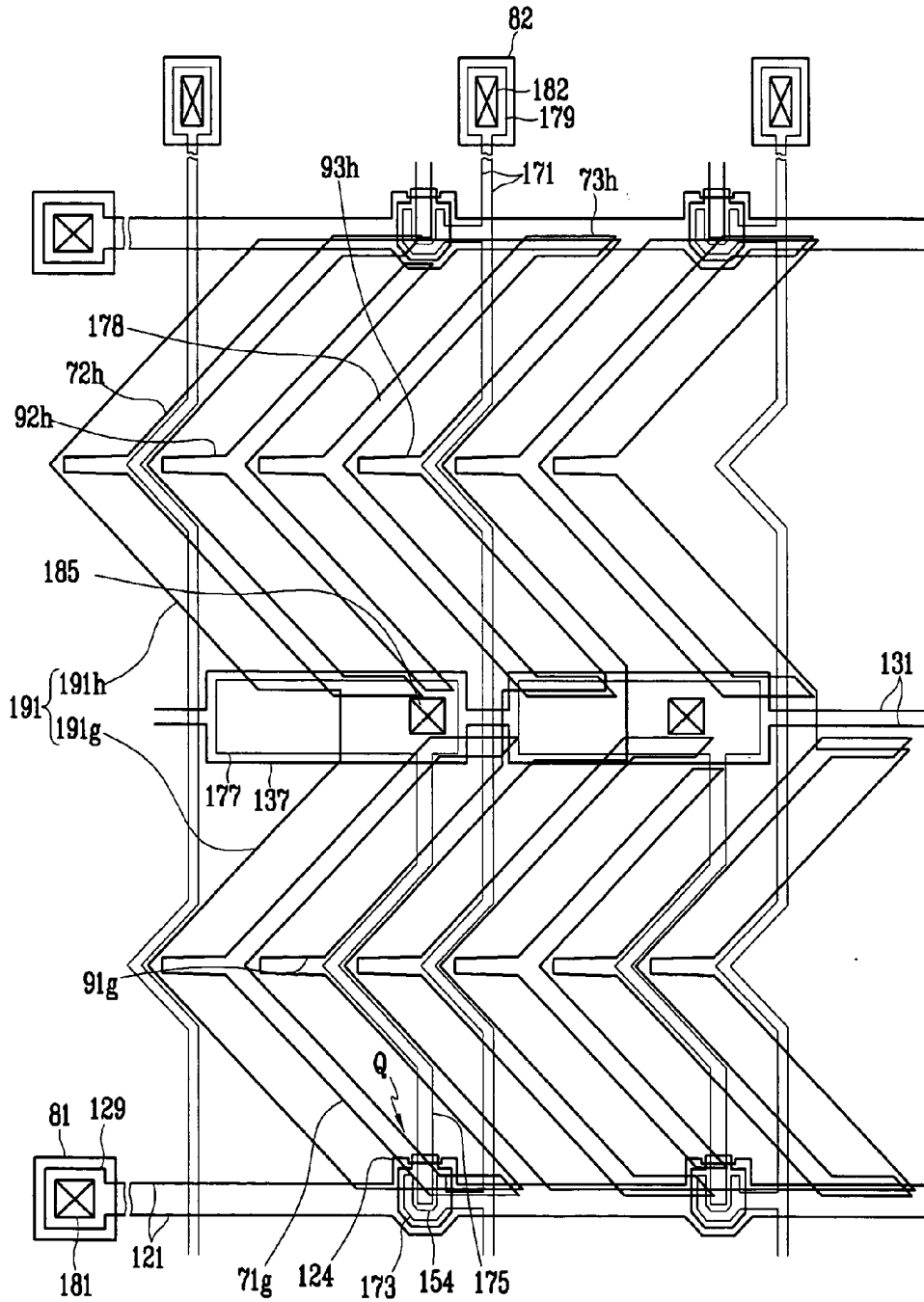

FIG. 21



LIQUID CRYSTAL DISPLAY

CROSS-REFERENCE TO RELATED PATENT APPLICATIONS

[0001] This Application claims priority to Korean patent application numbers 10-2005-0059157, filed on Jul. 1, 2005, and 10-2005-0072794, filed on Aug. 9, 2005, the contents of which are herein incorporated by reference in their entirety.

BACKGROUND OF THE INVENTION

[0002] 1. Technical Field

[0003] The present disclosure relates to a liquid crystal display.

[0004] 2. Discussion of Related Art

[0005] A liquid crystal display (LCD) is one of the most widely used flat panel displays. An LCD may include two panels provided with pixel electrodes and a common electrode (commonly referred to as "field generating electrodes") and having a liquid crystal (LC) layer interposed between the two panels. An LCD generates an electric field in the LC layer by applying voltages to the field generating electrodes. When an electric field is applied, the LC molecules in the LC layer are tilted with respect to an axis normal to the panels at angles dependent on the strength of the electric field. The LCD displays images by controlling the strength of the electric field, which determines orientations of LC molecules to adjust polarization of incident light.

[0006] An LCD further includes switching elements connected to the pixel electrodes and a plurality of signal lines such as gate lines and data lines for controlling the switching elements to apply voltages to the pixel electrodes.

[0007] A vertical alignment (VA) mode LCD, in which longitudinal axes of the LC molecules are aligned perpendicular to the two panels in the absence of an electric field, can produce a relatively high contrast ratio and wide reference viewing angle.

[0008] The wide viewing angle of the VA mode LCD can be realized by cutouts or protrusions on the field-generating electrodes. Since the tilt directions of the LC molecules are determined by the cutouts or the protrusions, the tilt directions can be distributed into several directions by appropriately arranging the cutouts and the protrusions such that the reference viewing angle is widened.

[0009] However, the protrusions and the cutouts may obstruct the passage of incident light, and the light transmittance may decrease as the number of protrusions or cutouts increases. In one method to increase the light transmittance, the area of the pixel electrodes is enlarged. However, in such a configuration, strong lateral electric fields are generated near the edges of the pixel electrodes. The lateral electric fields disorder the orientations of the LC molecules which generates texture and light leakage and lengthens the response time.

[0010] In addition, the VA mode LCD may have poor lateral visibility as compared with frontal visibility. For example, in a conventional LCD provided with cutouts in the field-generating electrodes, the luminance is enhanced toward the display's lateral sides, and, in the worse case,

the luminance difference between high grays vanishes such that the image cannot be perceived.

SUMMARY OF THE INVENTION

[0011] A liquid crystal display according to an exemplary embodiment of the present invention includes: a substrate; a pixel electrode disposed on the substrate and including a first subpixel electrode and a second subpixel electrode; and a common electrode facing the pixel electrode. The first subpixel electrode comprises a first edge, a second edge disposed opposite the first edge, and two first oblique edges substantially parallel to each other, the first oblique edges making an oblique angle with the first edge and the second edge and meeting the first edge. The second subpixel electrode comprises a first edge, a second edge disposed opposite the first edge, and two first oblique edges substantially parallel to or substantially perpendicular to the first oblique edges of the first subpixel electrode, the first oblique edges of the second subpixel electrode meeting the first edge of the second subpixel electrode. The first edge of the first subpixel electrode is adjacent to the first edge of the second subpixel electrode, and a length of the first edge of the first subpixel electrode is different from a length of the first edge of the second subpixel electrode. The first oblique edges of the first subpixel electrode are offset from the first oblique edges of the second subpixel electrode.

[0012] The liquid crystal display may further include a polarizer having a polarization axis making an angle of about 45 degrees with the first oblique edges of the first subpixel electrode and the first oblique edges of the second subpixel electrode.

[0013] A center of the first edge of the first subpixel electrode may be aligned with a center of the first edge of the second subpixel electrode.

[0014] The first subpixel electrode may further comprise two second oblique edges meeting the first oblique edges of the first subpixel electrode with making about a right angle. The second subpixel electrode may further comprise two second oblique edges meeting the first oblique edges of the second subpixel electrode with making about a right angle. The first oblique edges of the first subpixel electrode may make about a right angle with the first oblique edges of the second subpixel electrode.

[0015] The second subpixel electrode may include a first electrode part and a second electrode part separated from each other by the first subpixel electrode. The first electrode part may comprise the first oblique edges of the second subpixel electrode, and the second electrode part may comprise two second oblique edges substantially perpendicular to the first oblique edges of the second subpixel electrode. The first oblique edges of the first subpixel electrode may be substantially parallel to the first oblique edges of the second subpixel electrode.

[0016] The height of the first subpixel electrode may be substantially equal to a height of the second subpixel electrode. The first edge of the second subpixel electrode has a length about 1.8 to about 2 times a length of the second edge of the first subpixel electrode.

[0017] A distance between the first subpixel electrode and the second subpixel electrode may be equal to about 5.5 microns to about 7.5 microns.

[0018] The liquid crystal display may further include a first tilt direction determining member disposed at the common electrode.

[0019] The first tilt direction determining member may include a first cutout, wherein the first cutout may pass through one of the first and the second subpixel electrodes and may include an oblique portion extending substantially parallel to the first oblique edges of the first and the second subpixel electrodes.

[0020] The width of the first cutout may be equal to about 9.5 microns to about 10.5 microns.

[0021] The first cutout may further include a terminal portion connected to the oblique portion of the first cutout, overlapping the first or the second edge of the first or the second subpixel electrode, and having an edge making an angle larger than about 135 degrees.

[0022] The liquid crystal display may further include a second tilt direction determining member disposed at the second subpixel electrode.

[0023] The second tilt direction determining member may include a second cutout having an oblique portion bisecting the second subpixel electrode and extending substantially parallel to the first oblique edges of the second subpixel electrode.

[0024] The width of the second cutout may be equal to about 8 microns to about 10 microns.

[0025] The liquid crystal display may further include a storage electrode disposed on the substrate. The storage electrode may be disposed near a boundary between the first subpixel electrode and the second subpixel electrode adjacent to the first subpixel electrode in a row direction. The terminal portion of the first cutout may overlap the storage electrode. A distance between an edge of the storage electrode and an edge of the terminal portion adjacent to the edge of the storage electrode may be equal to or larger than about one micron.

[0026] A distance between the oblique portion of the first cutout and one of the first oblique edges of the first or the second subpixel electrode and a distance between the oblique portion of the second cutout and the oblique portion of the first cutout may be equal to about 25 microns to about 40 microns.

[0027] A distance between the first cutout and the second cutout may be shorter than a distance between the first cutout and one of the first oblique edges of the first or the second subpixel electrode.

[0028] The distance between the oblique portion of the second cutout and the oblique portion of the first cutout may be equal to about 20 microns to about 30 microns, and the distance between one of the first oblique edges of the second subpixel electrode and the oblique portion of the first cutout may be equal to about 20 microns to about 30 microns.

[0029] The oblique portion of the second cutout may meet the oblique portion of the first cutout passing through the first subpixel electrode.

[0030] The first subpixel electrode and the second subpixel electrode may have different voltages.

[0031] An area, of the first subpixel electrode may be smaller than an area of the second subpixel electrode, and the voltage of the first subpixel electrode may be higher than the voltage of the second subpixel electrode.

[0032] The area of the second subpixel electrode may be about 1.8 to about 2 times the area of the first subpixel electrode.

[0033] The first subpixel electrode and the second subpixel electrode may be supplied with different data voltages obtained from a single image information.

[0034] The liquid crystal display may further include: a first thin film transistor coupled to the first subpixel electrode; a second thin film transistor coupled to the second subpixel electrode; a first signal line coupled to the first thin film transistor; a second signal line coupled to the second thin film transistor; and a third signal line coupled to the first and the second thin film transistors and intersecting the first and the second signal lines.

[0035] The first thin film transistor may turn on to transmit a signal from the third signal line in response to a signal from the first signal line, while the second thin film transistor may turn on to transmit a signal from the third signal line in response to a signal from the second signal line.

[0036] The first and the second thin film transistors may turn on to transmit a signal from the first signal line in response to a signal from the third signal line, while the second thin film transistor may turn on to transmit a signal from the second signal line in response to a signal from the third signal line.

[0037] The first subpixel electrode and the second subpixel electrode may be capacitively coupled to each other.

[0038] The liquid crystal display may further include: a thin film transistor coupled to the first subpixel electrode; a first signal line coupled to the thin film transistor; and a second signal line coupled to the thin film transistor and intersecting the first signal line.

[0039] The first and the second subpixel electrodes may be connected to each other.

[0040] A liquid crystal display according to an exemplary embodiment of the present invention includes: a pixel electrode including a first subpixel electrode and a second subpixel electrode, each of the first and the second subpixel electrodes including two oblique edges disposed opposite each other and substantially parallel to each other, the first and the second subpixel electrodes arranged in a direction oblique to the oblique edges; a common electrode disposed opposite the pixel electrode; a liquid crystal layer disposed between the pixel electrode and the common electrode; a first tilt direction determining member provided at the second subpixel electrode, extending substantially parallel to the oblique edges, and determining a tilt direction of liquid crystal molecules in the liquid crystal layer; and a plurality of second tilt direction determining members provided at the common electrode and determining tilt directions of the liquid crystal molecules, each of the second tilt direction determining members including a first portion substantially parallel to the oblique edges and either disposed between the oblique edges or between one of the oblique edge and the first tilt direction determining member. Each of the first and the second subpixel electrodes is

divided into a plurality of sub-areas by the first or the second tilt direction determining members and the oblique edges. The number of the sub-areas in the first subpixel electrode is different from the number of the sub-areas in the second subpixel electrode. The oblique edges of the first subpixel electrode are offset from the oblique edges of the second subpixel electrode.

[0041] The liquid crystal display may further include a polarizer having a polarization axis making an angle of about 45 degrees with the oblique edges of the first subpixel electrode and the oblique edges of the second subpixel electrode.

[0042] The sub-areas may have substantially equal area.

[0043] An area of each of the sub-areas may be a relatively smaller area in relation to a distance of the sub-area from the oblique edges.

[0044] A liquid crystal display according to an exemplary embodiment of the present invention includes: a substrate; a first pixel electrode disposed on the substrate and including a first subpixel electrode and a second subpixel electrode; a second pixel electrode disposed on the substrate and including a third subpixel electrode and a fourth subpixel electrode; and a common electrode disposed opposite the first and the second pixel electrodes. Each of the first and the third subpixel electrodes comprises a first edge, a second edge disposed opposite the first edge, and two first oblique edges substantially parallel to each other, and the first oblique edges make an oblique angle with the first edge and the second edge and meet the first edge. Each of the second and the fourth subpixel electrodes comprises a first edge, a second edge disposed opposite the first edge, and two first oblique edges substantially parallel to or perpendicular to the first oblique edges of the first and the third subpixel electrodes, and the first oblique edges of the second and the fourth subpixel electrode meet the first edge of the second and the fourth subpixel electrode, respectively. The first edge of the first subpixel electrode is adjacent to the first edge of the second subpixel electrode, and the first edge of the third subpixel electrode is adjacent to the first edge of the fourth subpixel electrode. The first edge of the first subpixel electrode has a length different from a length of the first edge of the second subpixel electrode, and a length of the first edge of the third subpixel electrode may be different from a length of the first edge of the fourth subpixel electrode. The first oblique edges of the first subpixel electrode are offset from the first oblique edges of the second subpixel electrode, and the first oblique edges of the third subpixel electrode are offset from the first oblique edges of the fourth subpixel electrode.

[0045] Each of the first to the fourth subpixel electrodes may further comprise two second oblique edges meeting the first oblique edges thereof with making about a right angle. The first oblique edges of the first and the third subpixel electrodes may make an angle of about 90 degrees with the first oblique edges of the second and the fourth subpixel electrodes, respectively. The first and the second oblique edges of the first subpixel electrode may be adjacent to the first and the second oblique edges of the third subpixel electrode, respectively, and the first and the second oblique edges of the fourth subpixel electrode may be adjacent to the first and the second oblique edges of the second subpixel electrode, respectively. A center of the first edge of the first

subpixel electrode may be aligned with a center of the first edge of the second subpixel electrode, and a center of the first edge of the third subpixel electrode may be aligned with a center of the first edge of the fourth subpixel electrode.

[0046] The second subpixel electrode may include a first electrode part and a second electrode part separated from each other by the first subpixel electrode, and the fourth subpixel electrode may include a first electrode part and a second electrode part separated from each other by the third subpixel electrode. Each of the first and the third subpixel electrodes may further comprise two second oblique edges making about a right angle with the first oblique edges thereof, respectively. The first electrode part of the second or the fourth subpixel electrode may include the first oblique edges of the second or the fourth subpixel electrode, and the second electrode part of the second or the fourth subpixel electrode may include two second oblique edges making about a right angle with the first oblique edges of the second or the fourth subpixel electrode. The first oblique edges of the first and the third subpixel electrodes may be substantially parallel to the first oblique edges of the second and the fourth subpixel electrodes. The first oblique edges of the first electrode part of the second subpixel electrode may be adjacent to the first oblique edges of the first electrode part of the fourth subpixel electrode, and the first and the second oblique edges of the first subpixel electrode may be adjacent to the first and the second oblique edges of the third subpixel electrode, respectively.

[0047] The first or the second edges of the first to the fourth subpixel electrodes may make an angle of about 45 degrees or about 135 degrees with the first or the second oblique edges thereof.

[0048] The first to the fourth subpixel electrodes may have substantially the same height.

[0049] A length of the first edges of the second and the third subpixel electrodes may be about 1.8 to about 2 times a length of the second edges of the first and the fourth subpixel electrodes.

[0050] A liquid crystal display according to an exemplary embodiment of the present invention includes: a substrate; a pixel electrode disposed on the substrate and including a first subpixel electrode and a second subpixel electrode; and a common electrode facing the pixel electrode. Each of the first and the second subpixel electrodes comprises two curved edges substantially parallel to each other. The common electrode includes a first cutout, and the first and the second subpixel electrodes have a second cutout. A width of the second cutout is greater than a width of the first cutout.

[0051] The width of the second cutout may be greater than the width of the first cutout by about 1-2 microns. The width of the first cutout may be equal to about 9.5 microns to about 10.5 microns, and the width of the second cutout may be equal to about 8 microns to about 10 microns.

[0052] A distance between the first subpixel electrode and the second subpixel electrode may be equal to about 5.5 microns to about 7.5 microns.

[0053] The liquid crystal display may further include a storage electrode formed on the substrate and disposed near a boundary between the first subpixel electrode and the second subpixel electrode, wherein the first cutout or the

second cutout including a portion overlapping the storage electrode, and a distance between an edge of the storage electrode and an edge of the overlapping portion of the first cutout or the second cutout is greater than about one micron. The overlapping portion of the first cutout or the second cutout has a width that becomes narrow as goes to an end thereof.

[0054] The present invention will become readily apparent to those of ordinary skill in the art when descriptions of exemplary embodiments thereof are read with reference to the accompanying drawings.

BRIEF DESCRIPTION OF THE DRAWINGS

[0055] FIG. 1 is a block diagram of an LCD according to an exemplary embodiment of the present invention.

[0056] FIG. 2 is an equivalent circuit diagram of a pixel of an LCD according to an exemplary embodiment of the present invention.

[0057] FIGS. 3-5 are layout diagrams of pixel electrodes, common electrodes, color filters, and data lines in LC panel assemblies according to exemplary embodiments of the present invention.

[0058] FIG. 6 is a planar view of a base electrode forming a subpixel electrode shown in FIGS. 3-5.

[0059] FIGS. 7A and 7B are layout diagrams of pixel electrodes and common electrodes in LC panel assemblies according to exemplary embodiments of the present invention.

[0060] FIG. 8 is an equivalent circuit diagram of signal lines and a pixel of an LCD according to an exemplary embodiment of the present invention.

[0061] FIG. 9 is a layout view of a LC panel assembly according to an exemplary embodiment of the present invention.

[0062] FIG. 10 is a sectional view of the LC panel assembly shown in FIG. 9 taken along line X-X.

[0063] FIG. 11 is an equivalent circuit diagram of signal lines and a pixel of an LCD according to an exemplary embodiment of the present invention.

[0064] FIG. 12 is a layout view of an LC panel assembly according to an exemplary embodiment of the present invention.

[0065] FIG. 13 is a sectional view of the LC panel assembly shown in FIG. 12 taken along line XIII-XIII.

[0066] FIG. 14 is an equivalent circuit diagram of signal lines and a pixel of an LCD according to an exemplary embodiment of the present invention.

[0067] FIG. 15 is a layout view of a lower panel for a LC panel assembly according to an exemplary embodiment of the present invention.

[0068] FIG. 16 is a layout view of an upper panel for a LC panel assembly according to an exemplary embodiment of the present invention.

[0069] FIG. 17 is a layout view of a LC panel assembly including the lower panel shown in FIG. 15 and the upper panel shown in FIG. 16.

[0070] FIG. 18 is a sectional view of the LC panel assembly shown in FIG. 17 taken along line XVIII-XVIII.

[0071] FIG. 19 is a layout view of a LC panel assembly according to an exemplary embodiment of the present invention.

[0072] FIG. 20 is an equivalent circuit diagram of signal lines and a pixel of an LCD according to an exemplary embodiment of the present invention.

[0073] FIGS. 21 and 22 are layout views of an LC panel assembly according to exemplary embodiments of the present invention.

DESCRIPTION OF EXEMPLARY EMBODIMENTS

[0074] Hereinafter, exemplary embodiments of present invention will be described in detail with reference to the accompanying drawings

[0075] In the drawings, the thickness of layers, films and regions may be exaggerated for clarity. Like numerals refer to similar or identical elements throughout the description of the figures. It will be understood that when an element such as a layer, film, region or substrate is referred to as being "on" another element, it can be directly on the other element or intervening elements may also be present.

[0076] Hereinafter, an LCD according to an exemplary embodiment of the present invention will be described in detail with reference to FIGS. 1 and 2.

[0077] FIG. 1 is a block diagram of an LCD according to an exemplary embodiment of the present invention. FIG. 2 is an equivalent circuit diagram of a pixel of an LCD according to an exemplary embodiment of the present invention.

[0078] Referring to FIG. 1, an LCD includes a LC panel assembly 300, a gate driver 400 and a data driver 500 that are connected to the panel assembly 300, a gray voltage generator 800 connected to the data driver 500, and a signal controller 600.

[0079] The panel assembly 300 includes a plurality of signal lines (not shown) and a plurality of pixels PX connected thereto and arranged substantially in a matrix. As shown in FIG. 2, the panel assembly 300 includes a lower panel 100, an upper panel 200, and a LC layer 3 interposed therebetween.

[0080] The signal lines, which are provided on the lower panel 100, include a plurality of gate lines (not shown) transmitting gate signals (also referred to as "scanning signals") and a plurality of data lines (not shown) transmitting data signals. The gate lines extend substantially in a row direction and substantially parallel to each other, while the data lines extend substantially in a column direction and substantially parallel to each other.

[0081] Referring to FIG. 2, each pixel PX includes a pair of subpixels and each subpixel includes a liquid crystal (LC) capacitor Clc1/Clc2. At least one of the two subpixels further includes a switching element (not shown) connected to a gate line, a data line, and a LC capacitor Clc1/Clc2.

[0082] The LC capacitor Clc1/Clc2 includes a subpixel electrode PE1/PE2 and a common electrode CE provided on

an upper panel **200** as two terminals. The LC layer **3** is disposed between the electrodes PE1/PE2 and CE functions as a dielectric of the LC capacitor Clc1/Clc2. A pair of subpixel electrodes PE1 and PE2 are separated from each other and form a pixel electrode PE. The common electrode CE is supplied with a common voltage Vcom and covers an entire surface of the upper panel **200**. The LC layer **3** has negative dielectric anisotropy. LC molecules in the LC layer **3** may be oriented so that longitudinal axes of the LC molecules are perpendicular to the surfaces of the panels **100** and **200** in absence of an electric field.

[0083] For a color display, each pixel PX uniquely represents one primary color (i.e., spatial division) or each pixel PX sequentially represents each primary color in turn (i.e., temporal division) such that a spatial or a temporal sum of the primary colors can be recognized as a desired color. For example the primary colors include red, green, and blue. FIG. 2 shows an example of spatial division in that each pixel PX includes a color filter CF representing one of the primary colors disposed in an area of the upper panel **200** facing the pixel electrode PE. Alternatively, the color filter CF is provided on or under the subpixel electrode PE1 or PE2 on the lower panel **100**.

[0084] A pair of polarizers (not shown) are attached to outer surfaces of the panels **100** and **200**. The polarization axes of the two polarizers may be crossed such that the crossed polarizers block the light incident onto the LC layer **3**. One of the polarizers may be omitted.

[0085] Referring again to FIG. 1, the gray voltage generator **800** generates a plurality of gray voltages related to the transmittance of the pixels PX. However, the gray voltage generator **800** may generate only a given number of gray voltages (herein referred to as "reference gray voltages") instead of generating all of the gray voltages.

[0086] The gate driver **400** is connected to the gate lines of the panel assembly **300** and synthesizes the gate-on voltage Von and the gate-off voltage Voff from an external device to generate gate signals Vg to be applied to the gate lines.

[0087] The data driver **500** is connected to the data lines of the panel assembly **300** and applies data voltages Vd, which are selected from the gray voltages supplied from the gray voltage generator **800**, to the data lines. However, the data driver **500** may generate gray voltages for all the grays by dividing the reference gray voltages when the gray voltage generator **800** generates reference gray voltages and then the data driver **500** selects the data voltages Vd from the generated gray voltages.

[0088] The signal controller controls the gate driver **400** and the data driver, etc.

[0089] Each of the processing units **400**, **500**, **600** and **800** may include at least one integrated circuit (IC) chip mounted on the LC panel assembly **300** or on a flexible printed circuit (FPC) film in a tape carrier package (TCP) type, which are attached to the panel assembly **300**. Alternately, at least one of the processing units **400**, **500**, **600** and **800** may be integrated into the panel assembly **300** along with the signal lines and the switching elements. Alternatively, all of the processing units **400**, **500**, **600** and **800** may be integrated into a single IC chip. Alternatively, one or more of the

processing units **400**, **500**, **600** and **800**, or at least one circuit element of the processing units **400**, **500**, **600** and/or **800**, may be external components.

[0090] The pixel electrodes, a common electrode, color filters, and data lines in LC panel assemblies according to exemplary embodiments of the present invention will be described in detail with reference to FIGS. 3, 4, 5, 6, 7A and 7B.

[0091] FIGS. 3-5 are layout diagrams of pixel electrodes, common electrodes, color filters, and data lines in LC panel assemblies according to exemplary embodiments of the present invention. FIG. 6 is a planar view of a base electrode forming a subpixel electrode shown in FIGS. 3-5. FIGS. 7A and 7B are layout diagrams of pixel electrodes and common electrodes in LC panel assemblies according to exemplary embodiments of the present invention.

[0092] Referring to FIGS. 3-5, each pixel electrode **191** of LC panel assemblies includes a first subpixel electrode **191a** and a second subpixel electrode **191b** that are separated from each other and adjacent to each other in a column direction. The subpixel electrodes **191a** and **191b** have cutouts **91**, **92**, **93**, **94** and **95**, and a common electrode CE (shown in FIG. 2) has a plurality of cutouts **71**, **72**, **73**, **74**, **75**, **76**, **77**, **78** and **79** facing the subpixel electrodes **191a** and **191b**. Red color filters **230R**, green color filters **230G**, and blue color filters **230B** extend along the pixel electrodes **191** adjacent in the column direction.

[0093] Both of the first and the second subpixel electrodes **191a** and **191b** forming a pixel electrode **191** may be coupled to respective switching elements (not shown). On the other hand, the first subpixel electrode **191a** may be coupled to a switching element (not shown), while the second subpixel electrode **191b** may be capacitively coupled to the first subpixel electrode **191a**. Each of the switching elements is connected to a gate line and a data line. Reference numeral **171** shown in FIGS. 3-4 denotes a data line when both of the first and the second subpixel electrodes **191a** and **191b** are coupled to respective switching elements.

[0094] Referring to FIGS. 3 and 4, each of the subpixel electrodes **191a** and **191b** has a shape that is substantially the same as a base electrode **193** shown in FIG. 6, or a shape defined by a pair of a base electrodes **193** adjacent in a row direction that are connected to each other at upper and lower ends. Each of the cutouts **71-73** in the common electrode CE has substantially the same shape as a cutout **70** shown in FIG. 6. The arrangements of the subpixel electrodes **191a** and **191b** and the cutouts **71-73** and **91-93** shown in FIGS. 3 and 4 are obtained by repeating the arrangement of the base electrode **193** and the cutout **70** in the row and column directions.

[0095] As shown in FIG. 6, the base electrode **193** has a pair of curved edges **193o1** and **193o2** and a pair of transverse edges **193t** and has a shape of a chevron. Each of the curved edges **193o1** and **193o2** includes a convex edge **193o1** meeting the transverse edges **193t** at an obtuse angle, for example, about 135 degrees, and a concave edge **193o2** meeting the transverse edges **193t** at an acute angle, for example, about 45 degrees. The curved edges **193o1** and **193o2**, which are formed by the 90-degree meeting of a pair of oblique edges, have a curved angle of about a right angle. Each base electrode **193** has a cutout **90** that extends from

a concave vertex CV on the concave edge 193o2 toward a convex vertex VV on the convex edge 193o1 and reaches near a center of the base electrode 193

[0096] The cutout 70 in the common electrode CE includes a curved portion 70o having a curved point CP, a center transverse portion 70t1 connected to the curved point CP of the curved portion 70o, and a pair of terminal transverse portions 70t2 connected to ends of the curved portion 70o. The curved portion 70o of the cutout 70 includes a pair of oblique portions meeting at about a right angle, extends substantially parallel to the curved edges 193o1 and 193o2 of the base electrode 193, and bisects the base electrode 193 into left and right halves. The center transverse portion 70t1 of the cutout 70 makes an obtuse angle, for example, about 135 degrees, with the curved portion 70o, and extends toward the convex vertex VV of the base electrode 193. The terminal transverse portions 70t2 are aligned with the transverse edges 193t of the base electrode 193 and make an obtuse angle, for example, about 135 degrees, with the curved portion 70o.

[0097] The base electrode 193 is divided into four sub-areas S1, S2, S3 and S4 by the cutouts 70 and 90. Each of the sub-areas S1-S4 has two primary edges defined by a curved portion 70o of the cutout 70 and by a curved edge 193o of the base electrode 193. The distance between the primary edges, i.e., the width of the sub-area S1-S4, may be equal to about 25 microns to about 40 microns.

[0098] The base electrode 193 and the cutout 70 has an inversion symmetry with respect to an imaginary straight line (herein referred to as a "center transverse line") connecting the convex vertex VV and the concave vertex CV of the base electrode 193.

[0099] As shown in FIGS. 3 and 4, the second subpixel electrode 191b has a shape defined by two base electrodes 193 that are connected at upper and lower ends thereof so that the concave edge of one of the two base electrodes 193 may neighbor the convex edge of the other of the two base electrodes 193. A gap between the two base electrodes 193 and a cutout 90 meeting the gap form a new cutout 92. The cutout 92 includes a curved portion bisecting the second subpixel electrode 191b into left and right halves and a transverse portion meeting the curved portion.

[0100] Referring to FIG. 6, the length L of a transverse edge 193t of the base electrode 193 is defined as the length of the base electrode 193, and the distance H between the two transverse edges 193t of the base electrode 193 is defined as the height of the base electrode 193. For example, the length and the height of a subpixel electrode including a base electrode 193 are defined in the above-described manner.

[0101] In FIGS. 3 and 4, the height of the first subpixel electrode 191a is substantially equal to the height of the second subpixel electrode 191b, and the length of the second subpixel electrode 191b is about 1.8 to about 2 times the length of the first subpixel electrode 191a. Accordingly, the area of the second subpixel electrode 191b is about 1.8 to about 2 times the area of the first subpixel electrode 191a.

[0102] As shown in FIGS. 3 and 4, the first subpixel electrode 191a and the second subpixel electrode 191b are alternately arranged in the row and column directions. Regarding the arrangement of the subpixel electrodes 191a

and 191b in the row direction, the center transverse line of the first subpixel electrode 191a coincides with the first subpixel electrode 191a of the second subpixel electrode 191b. The convex edge of the first subpixel electrode 191a neighbors the concave edge of the second subpixel electrode 191b, and the concave edge of the first subpixel electrode 191a neighbors the convex edge of the second subpixel electrode 191b.

[0103] Regarding the arrangement in the column direction, since the lengths of the first and the second subpixel electrodes 191a and 191b are different, various arrangements are possible. One exemplary arrangement is to deviate the curved edges of one of the two subpixel electrodes 191a and 191b from the curved edges of the other of the two subpixel electrodes 191a and 191b. In an exemplary embodiment of the present invention shown in FIG. 3, the first subpixel electrode 191a is aligned with a center of the second subpixel electrode 191b. Alternatively, a curved edge of one of the subpixel electrodes 191a and 191b may meet a curved edge of the other of the subpixel electrodes 191a and 191b. In an exemplary embodiment of the present invention shown in FIG. 4, the convex edges (left edges) and the concave edges (right edges) of the first subpixel electrode 191a and the second subpixel electrode 191b are alternately aligned.

[0104] As shown in FIG. 3, the curved portion of the cutout 71 bisecting the first subpixel electrode 191a is connected to the curved portion of the cutout 92 bisecting the second subpixel electrode 191b. The convex edge and the concave edge of the first subpixel electrode 191a are connected to the curved portions of the cutouts 72 and 73 bisecting the base electrodes of the second subpixel electrode 191b. In other words, the curved edges of the subpixel electrodes 191a and 191b or the curved portions of the cutouts 92 in a subpixel row may be connected to the curved portions of the cutouts 71-73 of the common electrode CE in a subpixel row adjacent thereto.

[0105] Alternatively, as shown in FIG. 4, the convex edge of the first subpixel electrode 191a is connected to the convex edge of the second subpixel electrode 191b or to the curved portion of the cutout 92 bisecting the second subpixel electrode 191b, and the concave edge of the first subpixel electrode 191a is connected to the curved portion of the cutout 92 of the second subpixel electrode 191b or to the concave edge of the second subpixel electrode 191b. In other words, the curved portions of the subpixel electrodes 191a and 191b or the curved portions of the cutouts in adjacent subpixel columns may be connected to each other, and the curved portions of the cutouts 71-73 of the common electrode CE in adjacent subpixel columns may be connected to each other.

[0106] As shown in FIG. 3, the first subpixel electrode 191a and the second subpixel electrode 191b are aligned at a center thereof, and the data lines 171 are regularly arranged in a predetermined period. In FIG. 4, since the first subpixel electrode 191a and the second subpixel electrode 191b having a length ratio of about 1:2 are aligned with each other alternately at left and right edges, the distance between the data lines 171 varies at a ratio of about 1:2.

[0107] In an exemplary embodiment of the present invention shown in FIG. 5, one of the first and the second subpixel electrodes 191a and 191b of each pixel electrode 191 shown

in FIG. 3 is divided into a pair of electrode parts **191a1** and **191a2** (or **191b1** and **191b2**) disposed above and below the other of the first and the second subpixel electrodes **191a** and **191b**. In addition, each of the cutouts **71-73** corresponding to the divided one of the subpixel electrodes **191a** and **191b** is divided into cutout pieces **74** and **75**, **76** and **77**, or **78** and **79** disposed at corresponding positions. A pair of the electrode parts **191a1** and **191a2** (or **191b1** and **191b2**) are electrically connected to each other.

[0108] Each of the electrode parts **191a1**, **191a2**, **191b1** and **191b2** and each of the cutout pieces **74-79** may be obtained by dividing the subpixel electrodes **191a** and **191b** shown in FIG. 3 along the transverse cutouts **91** and **93** or along the center transverse line connecting the transverse portions of the cutout **92**.

[0109] Each of the electrode parts **191a1**, **191a2**, **191b1** and **191b2** has a shape of nearly a parallelogram having a pair of transverse edges extending substantially parallel to each other and a pair of oblique edges extending substantially parallel to each other. The transverse cutouts **91** and **93** or the transverse portions of the cutout **92** extending along the dividing lines form boundaries of the electrode parts **191a1**, **191b1**, **191a2** and **191b2**. Two oblique portions forming the curved portion of the cutout **92**, which are divided by the dividing line, form oblique cutout pieces **94** and **95**. Each of the cutout pieces **74-79** of the common electrode CE which are divided by the dividing lines includes an oblique portion and transverse portions connected to the ends of the oblique portion. The transverse portions of the cutout pieces **74-79** make obtuse angles with the oblique portion, extending along the transverse edges of the electrode parts **191a1**, **191a2**, **191b1** and **191b2**, overlapping the transverse edges of the electrode parts **191a1**, **191a2**, **191b1** and **191b2**.

[0110] The exemplary embodiment of the present invention shown in FIGS. 7A and 7B are substantially the same as those shown in FIGS. 3 and 5, respectively, except that the sub-areas of the second subpixel electrode **191b** have different sizes. Referring to the figures, two inner sub-areas SA1 among four sub-areas arranged in the row direction have a width L1 smaller than a width L2 of two outer sub-areas SA2. The width L1 of the inner sub-areas SA1 may be equal to about 20 microns to about 30 microns, while the width L2 of the inner sub-areas SA2 may be equal to about 30 microns to about 40 microns.

[0111] In the above-described arrangements, the first and the second subpixel electrodes **191a** and **191b** are arranged in the row or column direction, for example, to balance over all arrangements, and the subpixel electrodes **191a** and **191b** having an areal ratio of about 1:2 are well organized and may increase aperture ratio.

[0112] The color filters **230R**, **230G** and **230B** have equal area, for example, to facilitate the balance of the colors.

[0113] Hereinafter, operations of the above-described LCDs shown in FIGS. 1-7B will be described in detail.

[0114] The signal controller **600** is supplied with input image signals R, G and B and input control signals controlling the display thereof from an external graphics controller (not shown). The input image signals R, G and B contains luminance information of each pixel PX, and the luminance has a predetermined number of grays, such as for example,

1024 ($=2^{10}$), 256 ($=2^8$) or 64 ($=2^6$). The input control signals include a vertical synchronization signal Vsync, a horizontal synchronization signal Hsync, a main clock MCLK, and a data enable signal DE, etc.

[0115] After generating the gate control signals CONT1 and the data control signals CONT2 and processing the input image signals R, G and B suitable for the operations of the panel assembly **300** and the data driver **500** on the basis of the input control signals and the input image signals R, G and B, the signal controller **600** transmits the gate control signals CONT1 to the gate driver **400**, and the processed image signals DAT and the data control signals CONT2 to the data driver **500**. The output image signals DAT are digital signals having a predetermined number of values (or grays).

[0116] The gate control signals CONT1 include a scanning start signal STV for instructing to start scanning and at least a clock signal for controlling the output time of the gate-on voltage Von. The gate control signals CONT1 may further include an output enable signal OE for defining the duration of the gate-on voltage Von.

[0117] The data control signals CONT2 include a horizontal synchronization start signal STH for informing of start of data transmission for a group of subpixels, a load signal LOAD for instructing to apply the data voltages to the panel assembly **300**, and a data clock signal HCLK. The data control signal CONT2 may further include an inversion signal RVS for reversing the polarity of the data voltages (with respect to the common voltage Vcom).

[0118] Responsive to the data control signals CONT2 from the signal controller **600**, the data driver **500** receives a packet of the image data DAT for the group of subpixels from the signal controller **600**. The data driver **500** converts the image data DAT into analog data voltages selected from the gray voltages supplied from the gray voltage generator **800**, and applies the data voltages to the data lines.

[0119] The gate driver **400** applies the gate-on voltage Von to the gate line in response to the gate control signals CONT1 from the signal controller **600**, thereby turning on the switching elements connected thereto. The data voltages applied to the data lines are supplied to the subpixels through the activated switching elements.

[0120] Referring to FIGS. 3-7B, when the first subpixel electrode **191a** and the second subpixel electrode **191b** forming a pixel electrode **191** are coupled to respective switching elements, for example, when each of the subpixels includes its own switching element, the two subpixels may be supplied with respective data voltages at different times through the same data line or through different data lines, or at substantially the same time through different data lines. However, when the first subpixel electrode **191a** is coupled to a switching element (not shown) and the second subpixel electrode **191b** is capacitively coupled to the first subpixel electrode **191a**, one subpixel including the first subpixel electrode **191a** may be directly supplied with data voltages through the switching elements, while the other subpixel including the second subpixel electrode **191b** may have a voltage that varies depending on the voltage of the first subpixel electrode **191a**. The first subpixel electrode **191a** having a relatively small area may have a voltage (relative to the common voltage) that is greater than the second subpixel electrode **191b** having a relatively large area.

[0121] On the other hand, after two subpixel electrodes **191a** and **191b** are charged with the same voltage, the voltages of the subpixel electrodes **191a** and **191b** may be differentiated from each other by using storage capacitors (not shown), etc.

[0122] When the voltage difference is generated between two terminals of the LC capacitor Clc1/Clc2, a primary electric field substantially perpendicular to the surfaces of the panels **100** and **200** is generated in the LC layer **3** and both the pixel electrodes PE and the common electrode CE are commonly referred to as field generating electrodes. The LC molecules in the LC capacitor Clc1/Clc2 tend to change their orientations in response to the electric field so that their longitudinal axes may be perpendicular to the field direction. The molecular orientations determine the polarization of light passing through the LC layer **3**. The polarizer(s) converts the light polarization into the light transmittance such that the pixels PX display the luminance represented by the image signal DAT.

[0123] The tilt angle of the LC molecules depends on the strength of the electric field. Since the voltages of the LC capacitors Clc1 and Clc2 are different from each other, the tilt angles of the LC molecules in the subpixels are different from each other, and thus the luminances of the two subpixels are different. The voltages of the two subpixels can be adjusted so that an image viewed from a lateral side is the closest to an image viewed from the front, that is, a lateral gamma curve is the closest to the front gamma curve, improving the lateral visibility.

[0124] The area of the subpixel electrode **191a** having a voltage (relative to the common voltage Vcom) higher than that of the second subpixel electrode **191b** may have an area smaller than that of the second subpixel electrode **191b**, such that the lateral gamma curve further approaches the front gamma curve. For example, when the ratio of the areas of the first subpixel electrode **191a** and the second subpixel electrode **191b** is equal to about 1:2, the lateral gamma curve further approaches the front gamma curve to further improve the lateral visibility.

[0125] The tilt direction of the LC molecules is firstly determined by a horizontal field component. The horizontal field component is generated by the cutouts **71-73** and **91-93** and the cutout pieces **94** and **95** (cutout pieces **94** and **95** may also be referred to as cutouts) of the field generating electrodes **191** and CE and the edges of the subpixel electrodes **191a** and **191b**, and the electrode parts **191a1**, **191a2**, **191b1** and **191b2** (electrode parts **191a1**, **191a2**, **191b1** and **191b2** may also be referred to as subpixel electrodes) which distort the primary electric field. The horizontal field component is substantially perpendicular to the edges of the cutouts **71-79** and **91-95**, and substantially perpendicular to the edges of the subpixel electrodes **191a**, **191b**, **191a1**, **191a2**, **191b1** and **191b2**.

[0126] Referring to FIGS. 3-7B, since the LC molecules on each of the sub-areas divided by a set of the cutouts **71-79** and **91-95** tilt perpendicular to the major edges of the sub-area, the azimuthal distribution of the tilt directions are localized to four directions, increasing the reference viewing angle of the LCD.

[0127] The width of the sub-areas, i.e., the distance between the oblique portions of the cutouts **71-79** of the

common electrode CE and the oblique edges of the subpixel electrodes **191a**, **191b**, **191a1**, **191a2**, **191b1** and **191b2**, or the distance between the cutouts **91-95** is may be equal to about 25 microns to about 40 microns, as described above, such that the horizontal component of the primary electric field can be suitably used and the decrease of the aperture ratio caused by the cutouts **71-79** and **91-95** can be reduced.

[0128] The direction of a secondary electric field due to the voltage difference between adjacent pixel electrodes **191** is perpendicular to the major edges of the sub-areas. Accordingly, the field direction of the secondary electric field coincides with that of the horizontal component of the primary electric field. The secondary electric field between the adjacent pixel electrodes **191** enhances the determination of the tilt directions of the LC molecules. Accordingly, the control of the LC molecules may be enhanced and the delay of the response time caused by the increase of textures under the increase of the width of the sub-areas may be prevented.

[0129] The inner sub-areas in the second subpixel electrode **191b**, **191b1** and **191b2** are far from the boundaries of the pixel electrode **191** and thus are less affected by the secondary electric field. The structures shown in FIGS. 7A and 7B, wherein the width L1 of the inner sub-areas SA1 is smaller than the width L2 of the outer sub-areas SA2, properly control the LC molecules in both the inner sub-areas SA1 and the outer sub-areas SA2.

[0130] By repeating this procedure by a unit of a horizontal period (which is denoted by "1H" and equal to one period of the horizontal synchronization signal Hsync or the data enable signal DE), all the pixels PX are supplied with data voltages.

[0131] When the next frame starts after one frame finishes, the inversion control signal RVS applied to the data driver **500** is controlled such that the polarity of the data voltages is reversed (which is referred to as "frame inversion"). The inversion control signal RVS may be also controlled such that the polarity of the image data signals flowing in a data line are periodically reversed during one frame (for example, row inversion and dot inversion), or the polarity of the image data signals in one packet are reversed (for example, column inversion and dot inversion).

[0132] Among the above-described inversion types, the dot inversion, etc., reverses the polarities of the data voltages of adjacent data lines and repeatedly reverses the polarity of each data line between the positive and the negative. In FIGS. 3 and 4, the data voltages of the left and right data lines **171** have positive polarity, while the data voltage of the middle data line **171** has negative polarity. However, their polarity will be reversed soon and the reverse of the polarity will be repeated.

[0133] On the other hand, a pixel electrode **191** and a data line **171** adjacent thereto form a parasitic capacitance that varies the voltage of the pixel electrode **191**. For examples, the voltage of the pixel electrode **191** rises as the voltage of the data line **171** rises, while the voltage of the pixel electrode **191** drops as the voltage of the data line **171** drops. Therefore, when the voltage of the data line **171** changes from the negative polarity to the positive polarity, the voltage of the pixel electrode **191** increases. Conversely, when the voltage of the data line **171** changes from the positive polarity to the negative polarity, the voltage of the

pixel electrode **191** decreases. Since a pixel electrode **191** overlaps two data lines **171** having opposite polarity voltages as shown in FIGS. **3** and **4**, the parasitic capacitance between the pixel electrodes **191** and one of the two data lines **171** raises the voltage of the pixel electrode **191**, while the parasitic capacitance between the pixel electrode **191** and the other of the data lines **171** lowers the voltage of the pixel electrode **191**.

[**0134**] The voltage variation of the pixel electrode **191** depends on the parasitic capacitance between the pixel electrode **191** and the data line **171**, and the parasitic capacitance is proportional to an overlapping area between the pixel electrode **191** and the data line **171**.

[**0135**] Although each of the pixel electrodes **191** shown in FIGS. **3** and **4** overlaps two data lines **171**, the overlapping areas between the pixel electrode **191** and the two data lines **171** approach each other more in FIG. **3** as compared to in FIG. **4**, such that the voltage rise and the voltage drop caused by the parasitic capacitances are nearly cancelled to reduce the voltage variation of the pixel electrode **191**.

[**0136**] The voltage across the LC capacitor **Clc1** or **Clc2** forces the LC molecules in the LC layer **3** to be reoriented into a stable state corresponding to the voltage. The reorientation of the LC molecules takes time since the response time of the LC molecules is slow. The LC molecules continue to reorient themselves to vary the light transmittance (or the luminance) until they reach the stable state on the condition that the application of the voltage across the LC capacitor **Clc1** or **Clc2** is maintained. When the LC molecules reach the stable state and the reorientation stops, the light transmittance becomes fixed.

[**0137**] A pixel voltage in such a stable state is referred to as a target pixel voltage, and a light transmittance in the stable state is referred to as a target light transmittance. The target pixel voltage and the target light transmittance have one-to-one correspondence.

[**0138**] Actually, since the time for turning on the switching element of each pixel **PX** to apply a data voltage to the pixel is limited, it is difficult for the LC molecules in the pixel **PX** to reach the stable state during the application of the data voltage. However, even though the switching element is turned off, the voltage across the LC capacitor **Clc1** or **Clc2** still exists and thus the LC molecules continue the reorientation such that the capacitance of the LC capacitor **Clc1** or **Clc2** changes. Ignoring leakage current, the total amount of electrical charges stored in the LC capacitor **Clc1** or **Clc2** is kept constant when the switching element turns off since one terminal of the LC capacitor **Clc1** or **Clc2** is floating. Therefore, the variation of the capacitance of the LC capacitor **Clc1** or **Clc2** results in the variation of the voltage across the LC capacitor **Clc1** or **Clc2**, i.e., the pixel voltage.

[**0139**] Consequently, when a pixel **PX** is supplied with a data voltage corresponding to a target pixel voltage (referred to as a "target data voltage" hereinafter), which is determined in the stable state, an actual pixel voltage of the pixel **PX** may be different from the target pixel voltage such that the pixel **PX** may not reach a corresponding target light transmittance. The actual pixel voltage differs from the target pixel voltage as the target transmittance differs from a light transmittance that the subpixel initially has.

[**0140**] Accordingly, a data voltage applied to the pixel **PX** is required to be higher or lower than a target data voltage and, for example, this can be realized by DCC (dynamic capacitance compensation).

[**0141**] DCC, which may be performed by the signal controller **600** or a separate image signal modifier, modifies an image signal of a frame (referred to as a "current image signal" hereinafter) for a subpixel to generate a modified current image signal (referred to as a "modified (current) image signal" hereinafter) based on an image signal of an immediately previous frame (referred to as a "previous image signal" hereinafter) for the subpixel. The modified image signal may be obtained by experiments, and the difference between the modified current image signal and the previous image signal is usually larger than the difference between the current image signal before modification and the previous image signal. However, when the current image signal and the previous image signal are equal to each other or the difference therebetween is small, the modified image signal may be equal to the current image signal (that is, the current image signal may not be modified).

[**0142**] In this way, the data voltages applied to the subpixels by the data driver **500** are higher or lower than the target data voltages.

[**0143**] However, the target transmittance may not be obtained by the above-described method. In the case of target transmittance, a predetermined voltage (referred to as a pre-tilt voltage hereinafter) is pre-applied to the subpixel to pre-tilt the LC molecules and then, a primary voltage is applied to the subpixel.

[**0144**] For this purpose, the signal controller **600** or an image signal modifier modifies a current image signal in consideration of an image signal of the next frame (referred to as a "next image signal" hereinafter) as well as a previous image signal. For example, if the next image signal is very different from the current image signal although the current image signal is equal to the previous image signal, the current image signal is modified to prepare the next frame.

[**0145**] The modification of the image signals and the data voltages may or may not be performed for the highest gray or the lowest gray. In order to modify the highest gray or the lowest gray, the range of the gray voltages generated by the gray voltage generator **800** may be widened as compared with the range of the target data voltages required for obtaining the range of the target luminance (or the target transmittance) represented by the grays of the image signals.

[**0146**] The application of DCC to the LCD according to an exemplary embodiment of the present invention reduces the response time of the liquid crystal so that the width of the sub-areas may be enlarged to increase the aperture ratio.

[**0147**] Hereinafter, a structure of a LC panel assembly according to an exemplary embodiment of the present invention will be described in detail with reference to FIGS. **1**, **2**, **5**, **8**, **9** and **10**.

[**0148**] FIG. **8** is an equivalent circuit diagram of signal lines and a pixel of an LCD according to an exemplary embodiment of the present invention.

[**0149**] The LC panel assembly shown in FIG. **8** includes a plurality of signal lines and a plurality of pixels **PX** connected thereto. The signal lines include a plurality of

pairs of gate lines GLa and GLb, a plurality of data lines DL, and a plurality of storage electrode lines SL extending substantially parallel to the gate lines GLa and GLb.

[0150] Each pixel PX includes a pair of subpixels PXa and PXb. Each subpixel PXa/PXb includes a switching element Qa/Qb connected to one of the gate lines GLa and GLb and one of the data lines DL, a LC capacitor Clca/Clcb coupled to the switching element Qa/Qb, and a storage capacitor Csta/Cstb connected between the switching element Qa/Qb and the storage electrode line SL.

[0151] The switching element Qa/Qb such as a thin film transistor (TFT) is provided on the lower panel 100 and may include three terminals: a control terminal connected to a gate line GLa/GLb; an input terminal connected to a data line DL; and an output terminal connected to the LC capacitor Clca/Clcb and the storage capacitor Csta/Cstb.

[0152] The storage capacitor Csta/Cstb is an auxiliary capacitor for the LC capacitor Clca/Clcb. The storage capacitor Csta/Cstb includes a subpixel electrode and a separate signal line, which is provided on the lower panel 100, overlapping the subpixel electrode via an insulator, and is supplied with a predetermined voltage such as the common voltage Vcom. Alternatively, the storage capacitor Csta/Cstb includes the subpixel electrode and an adjacent gate line called a previous gate line, which overlaps the pixel electrode via an insulator.

[0153] Since the LC capacitor Clca/Clcb is described above with reference to FIG. 2, further description thereof will be omitted.

[0154] In the LCD shown in FIG. 8, the signal controller 600 receives input image data R, G and B and converts each input image data R, G and B for each pixel into a plurality of output image data DAT for two subpixels PXa and PXb to be supplied to the data driver. Otherwise, the gray voltage generator 800 generates separate groups of gray voltages for two subpixels PXa and PXb. The two groups of gray voltages are alternately supplied by the gray voltage generator 800 to the data driver 500 or alternately selected by the data driver 500 such that the two subpixels PXa and PXb are supplied with different voltages.

[0155] The values of the converted output image signals and the values of the gray voltages in each group may be determined such that the synthesis of gamma curves for the two subpixels PXa and PXb approaches a reference gamma curve at a front view. For example, the synthesized gamma curve at a front view coincides with the most suitable reference gamma curve at a front view, and the synthesized gamma curve at a lateral view is the most similar to the reference gamma curve at a front view.

[0156] An example of an LC panel assembly shown in FIG. 8 according to an exemplary embodiment of the present invention will be described in detail with reference to FIGS. 9 and 10.

[0157] FIG. 9 is a layout view of a LC panel assembly according to an exemplary embodiment of the present invention, and FIG. 10 is a sectional view of the LC panel assembly shown in FIG. 9 taken along line X-X.

[0158] Referring to FIGS. 9 and 10, an LC panel assembly includes a lower panel 100, an upper panel 200 facing the lower panel 100, and a LC layer 3 interposed between the panels 100 and 200.

[0159] First, the lower panel 100 will be described.

[0160] A plurality of gate conductors including a pair of first and second gate lines 121a and 121b and a pair of first and second storage electrode lines 131a and 131b are formed on an insulating substrate 110 such as transparent glass or plastic.

[0161] The gate lines 121a and 121b transmit gate signals, extend substantially in a transverse direction, and are disposed at relatively upper and lower positions, respectively.

[0162] The first gate line 121a includes a first gate electrode 124a extending downward and an end portion 129a having a large area for contact with another layer or an external driving circuit. The second gate line 121b includes a second gate electrode 124b extending toward upward and an end portion 129b having a large area for contact with another layer or an external driving circuit. The gate lines 121a and 121b may extend to be connected to a gate driver 400 that may be integrated on the substrate 110.

[0163] The first and the second storage electrode lines 131a and 131b are supplied with a predetermined voltage such as the common voltage Vcom and include stems extending substantially parallel to the gate lines 121a and 121b and a plurality of storage electrodes 137a1, 137a2 and 137b branching from the stems. Each of the first and the second storage electrode lines 131a and 131b is disposed between the first gate line 121a and the second gate line 121b. The stem of the first storage electrode line 131a is closer to the first gate line 121a than the second gate line 121b, while the stem of the second storage electrode line 131b is closer to the second gate line 121b than the second gate line 121a. The distance between the first/second gate line 121a/121b and the first/second storage electrode line 131a/131b adjacent thereto is nearly equal to the distance between the first storage electrode line 131a and the second storage electrode line 131b adjacent thereto.

[0164] The first storage electrode line 131a includes a pair of first and second storage electrodes 137a1 and 137a2 extending upward and downward. The second storage electrode line 131b includes a third storage electrode 137b extending downward and coinciding with the second storage electrode 137a2. However, the storage electrode lines 131a and 131b may have various shapes and arrangements.

[0165] The gate conductors 121a, 121b, 131a and 131b may be made of Al containing metal such as Al and Al alloy, Ag containing metal such as Ag and Ag alloy, Cu containing metal such as Cu and Cu alloy, Mo containing metal such as Mo and Mo alloy, Cr, Ta, or Ti. However, they may have a multi-layered structure including two conductive films (not shown) having different physical characteristics. One of the two films may be made of a low resistivity metal including, for example, an Al containing metal, an Ag containing metal, and an Cu containing metal for reducing signal delay or voltage drop. The other film may be made of material such as Mo containing metal, Cr, Ta, or Ti, which has good physical, chemical, and electrical contact characteristics with other materials such as indium tin oxide (ITO) or indium zinc oxide (IZO). Good examples of the combination of the two films are a lower Cr film and an upper Al (alloy) film and a lower Al (alloy) film and an upper Mo (alloy) film. However, the gate conductors 121a, 121b, 131a and 131b may be made of various metals or conductors.

[0166] The lateral sides of the gate conductors **121a**, **121b**, **131a** and **131b** are inclined relative to a surface of the substrate, and the inclination angle thereof ranges about 30-80 degrees.

[0167] A gate insulating layer **140** that may comprise silicon nitride (SiNx) or silicon oxide (SiOx) is formed on the gate conductors **121a**, **121b**, **131a** and **131b**.

[0168] First and second semiconductor islands **154a** and **154b** that may be made of hydrogenated amorphous silicon (abbreviated to "a-Si") or polysilicon are formed on the gate insulating layer **140**. The first/second semiconductor island **154a/154b** is disposed on the first/second gate electrode **124a/124b**.

[0169] A pair of ohmic contact islands **163b** and **165b** are formed on the semiconductor island **154b**, and a pair of ohmic contact islands (not shown) are formed on the semiconductor island **154a**. The ohmic contact islands **163b** and **165b** may be made of n+hydrogenated a-Si heavily doped with n type impurity such as phosphorous or they may be made of silicide.

[0170] The lateral sides of the semiconductor islands **154a** and **154b** and the ohmic contacts **163b** and **165b** are inclined relative to the surface of the substrate **110**, and the inclination angles thereof may be in a range of about 30 degrees to about 80 degrees.

[0171] A plurality of data conductors including a data line **171** and a pair of first and second drain electrodes **175a** and **175b** are formed on the ohmic contacts **163b** and **165b** and the gate insulating layer **140**.

[0172] The data line **171** transmits data signals and extends substantially in the longitudinal direction to intersect the gate lines **121a** and **121b** and the storage electrode lines **131a** and **131b**. The data line **171** includes first and second source electrodes **173a** and **173b** extending toward the first and the second gate electrodes **124a** and **124b**, respectively, and curved like a character U or C. The data line **171** further includes an end portion **179** having a large area for contact with another layer or an external driving circuit. The data line **171** may extend to be connected to a data driver **500** that may be integrated on the substrate **110**.

[0173] The first and the second drain electrodes **175a** and **175b** are separated from each other and separated from the data line **171**. The first/second drain electrode **175a/175b** is disposed opposite the first/second source electrode **173a/173b** with respect to the first/second gate electrode **124a/124b**.

[0174] The first drain electrode **175a** starts from an end thereof enclosed by the first source electrode **173a** and extends downward along the first storage electrode **137a1**. The first drain electrode **175a** includes an expansion **177a** extending left and right along the first storage electrode line **131a** near the intersection with the first storage electrode line **131a**.

[0175] The second drain electrode **175b** starts from an end thereof enclosed by the second source electrode **173b**, extends upward along the third storage electrode **137b** and the second storage electrode **137a2**, and ends after crossing the first gate line **131a**. The second drain electrode **175b** includes an expansion **177b1** extending left and right along the second storage electrode line **131b** near the intersection

with the second storage electrode line **131b** and further includes a wide end portion **177b2**.

[0176] The first/second gate electrode **124a/124b**, the first/second source electrode **173a/173b**, and the first/second drain electrode **175a/175b** along with the first/second semiconductor island **154a/154b** form a first/second TFT Qa/Qb having a channel formed in the first/second semiconductor island **154a/154b** disposed between the first/second source electrode **173a/173b** and the first/second drain electrode **175a/175b**.

[0177] The data conductors **171**, **175a** and **175b** may be made of refractory metals such as Cr, Mo, Ta, Ti, or alloys thereof. It is to be understood that the data conductors **171**, **175a** and **175b** may have a multilayered structure including a refractory metal film (not shown) and/or a low resistivity film (not shown). For example, the multi-layered structure may comprise a double-layered structure including a lower Cr/Mo (alloy) film and an upper Al (alloy) film and a triple-layered structure of a lower Mo (alloy) film, an intermediate Al (alloy) film, and an upper Mo (alloy) film. However, the data conductors **171**, **175a** and **175b** may be implemented using various metals or other conductive materials.

[0178] The data conductors **171**, **175a** and **175b** may have inclined edge profiles. For example, the inclination angles thereof may be in a range about 30 degrees to about 80 degrees.

[0179] The ohmic contacts **163b** and **165b** are interposed only between the underlying semiconductor islands **154a** and **154b** and the overlying data conductors **171**, **175a** and **175b** thereon and reduce the contact resistance therebetween. The semiconductor islands **154a** and **154b** include some exposed portions, which are not covered with the data conductors **171**, **175a** and **175b**, that are located between the source electrodes **173a** and **173b** and the drain electrodes **175a** and **175b**.

[0180] A passivation layer **180** is formed on the data conductors **171**, **175a** and **175b** and the exposed portions of the semiconductor islands **154a** and **154b**. The passivation layer **180** may comprise an inorganic or organic insulator and it may have a flat top surface. Examples of the inorganic insulator include silicon nitride and silicon oxide. The organic insulator may have photosensitivity and dielectric constant less than about 4.0. The passivation layer **180** may include a lower film of inorganic insulator and an upper film of organic insulator such that it takes the insulating characteristics of the organic insulator while preventing the exposed portions of the semiconductor islands **154a** and **154b** from being damaged by the organic insulator.

[0181] The passivation layer **180** has a contact hole **182** exposing the end portion **179** of the data line **171**, a contact hole **185a** exposing the expansion **177a** of the first drain electrode **175a**, and contact holes **185b1** and **185b2** exposing the expansion **177b1** and the end portion **177b2** of the second drain electrode **175b**. The passivation layer **180** and the gate insulating layer **140** have contact holes **181a** and **181b** exposing the end portions **129a** and **129b** of the gate lines **121a** and **121b**.

[0182] A pixel electrode **191** and a plurality of contact assistants **81a**, **81b** and **82** are formed on the passivation layer **180**. The pixel electrode **191** and a plurality of contact

assistants **81a**, **81b** and **82** may comprise a transparent conductor such as ITO, IZO, or reflective conductor such as Ag, Al, Cr, or alloys thereof.

[0183] The pixel electrode **191** includes a pair of first and second subpixel electrodes **191a** and **191b**, and the second subpixel electrode **191b** includes lower and upper electrode parts **191b1** and **191b2**. The first subpixel electrode **191a** has a cutout **91a**, and the lower/the upper electrode part **191b1/191b2** has a cutout **92b/93b**.

[0184] The first subpixel electrode **191a** is physically and electrically connected to the first drain electrode **175a** through the contact hole **185a**. The second subpixel electrode **191b** is physically and electrically connected to the second drain electrode **175b** through the contact hole **185b**.

[0185] The first storage electrode line **131a**, the expansion **177a** of the first drain electrode **175a**, and the contact hole **185a** lie on a straight line connecting curved points of the first subpixel electrode **191a**. Similarly, the second storage electrode line **131b**, the expansion **177b1** of the second drain electrode **175b**, and the contact hole **185b1** are disposed near a boundary between the first subpixel electrode **191a** and the lower electrode part **191b1**. In addition, the first gate line **121a** is disposed at a boundary between the first subpixel electrode **191a** and the upper electrode part **191b2**, and the second gate line **131b** is disposed near a boundary of the pixel electrode **191**. The line connecting the curved points of the first subpixel electrode **191a** and the boundaries of the first and the second subpixel electrodes **191a** and **191b** form boundaries of the above-described sub-areas, and thus this configuration can cover texture that may be generated by the disorder of the LC molecules near the boundaries of the sub-areas, improving the aperture ratio.

[0186] Since other features of the pixel **191** are described above with reference to FIG. 5, the detailed description thereof will be omitted.

[0187] A subpixel electrode **191a** or **191b** and a common electrode **270** of the upper panel **200** along with a portion of the LC layer **3** disposed therebetween form a LC capacitor C1ca or C1cb, which stores applied voltages after the TFT Qa or Qb turns off.

[0188] The first subpixel electrode **191a** and the first drain electrode **175a** connected thereto overlap the first storage electrode line **131a** including the first storage electrode **137a1** with the gate insulating layer **140** interposed therebetween to form a first storage capacitor Csta. The second subpixel electrode **191b** and the second drain electrode **175b** connected thereto with the gate insulating layer **140** interposed therebetween overlap the second storage electrode **137a2** and the second storage electrode line **131b** including the third storage electrode **137b** to form a second storage capacitor Cstb. The storage capacitors Csta and Cstb enhance the charge storing capacity of the LC capacitors C1ca and C1cb.

[0189] The storage electrode lines **131**, the wide end portions **177a** and **177b** of the first and the second drain electrodes **175a** and **175b**, the contact holes **185a** and **185b**, and the second gate lines **121b** are disposed near boundaries of adjacent rows of the unit electrodes. This configuration covers texture that appears near the boundaries due to the disorder of the molecular orientations, and increases the aperture ratio.

[0190] The contact assistants **81a**, **81b** and **82** are connected to the end portions **129a** and **129b** of the gate lines **121a** and **121b** and the end portion **179** of the data line **171** through the contact holes **181a**, **181b** and **182**, respectively. The contact assistants **81a**, **81b** and **82** protect the end portions **129a**, **129b** and **179** and enhance the adhesion between the end portions **129a**, **129b** and **179** and external devices.

[0191] The description of the upper panel **200** follows.

[0192] A light blocking member **220** is formed on an insulating substrate **210** such as transparent glass or plastic. The light blocking member **220** may include curved portions (not shown) facing the curved edges of the pixel electrode **191** on the lower panel **100** and widened portions (not shown) facing the TFTs Qa and Qb on the lower panel **100**. The light blocking member **220** preventing light leakage near the boundaries of the pixel electrode **191** and is also referred to as a black matrix. However, the light blocking member **220** may have other various shapes.

[0193] A color filter **230** is also formed on the substrate **210** and the light blocking member **220** and the color filter **230** is disposed substantially in the area enclosed by the light blocking member **220**. The color filter **230** may extend substantially in the longitudinal direction along the pixel electrode **191**. The color filter **230** may represent a primary color such as red, green, and blue.

[0194] An overcoat **250** is formed on the color filter **230** and the light blocking member **220**. The overcoat **250** may be made of (organic) insulator and it prevents the color filter **230** from being exposed and provides a flat surface. The overcoat **250** may be omitted.

[0195] A common electrode **270** is formed on the overcoat **250**. The common electrode **270** may be made of transparent conductive material such as ITO and IZO and has a plurality of cutouts **71a**, **72b** and **73b**, which are described above with reference to FIG. 3.

[0196] The number of the cutouts **71a**, **72b** and **73b** may be varied depending on the design factors, and the light blocking member **220** may also overlap the cutouts **71a**, **72b** and **73b** to block the light leakage near the cutouts **71a**, **72b** and **73b**.

[0197] Alignment layers **11** and **21** that may be homeotropic are coated on inner surfaces of the panels **100** and **200**.

[0198] Polarizers **12** and **22** are provided on outer surfaces of the panels **100** and **200** so that their polarization axes may be crossed and the polarization axes may make about 45 degrees with the curved edges of the subpixel electrodes **191a** and **191b** for increasing light efficiency. One of the polarizers **12** and **22** may be omitted when the LCD is a reflective LCD.

[0199] The LCD may further include at least one retardation film (not shown) for compensating the retardation of the LC layer **3**. The LCD may further include a backlight unit (not shown) supplying light to the LC layer **3** through the polarizers **12** and **22**, the retardation film, and the panels **100** and **200**.

[0200] The LC layer **3** may have a negative dielectric anisotropy and be subjected to a vertical alignment.

[0201] The shapes and the arrangements of the cutouts **71a**, **72b**, **73b**, **92b** and **93b** may be modified.

[0202] At least one of the cutouts **71a**, **72b**, **73b**, **92b** and **93b** can be substituted with protrusions (not shown) or depressions (not shown). The protrusions may comprise an organic or inorganic material and disposed on or under the field generating electrode **191** or **270**.

[0203] A structure of an LC panel assembly according to another exemplary embodiment of the present invention will be described in detail with reference to FIGS. **1**, **2**, **5**, **11**, **12** and **13**.

[0204] FIG. **11** is an equivalent circuit diagram of signal lines and a pixel of an LCD according to an exemplary embodiment of the present invention.

[0205] The LC panel assembly shown in FIG. **11** includes a plurality of signal lines and a plurality of pixels PX connected thereto. The signal lines include a plurality of gate lines GL, a plurality of pairs of data lines DL_a and DL_b, and a plurality of storage electrode lines SL.

[0206] Each pixel PX includes a pair of subpixels PX_c and PX_d. Each subpixel PX_c/PX_d includes a switching element Q_c/Q_d connected to one of the gate lines GL and one of the data lines DL_a and DL_b, a LC capacitor Cl_{cc}/Cl_{cd} coupled to the switching element Q_c/Q_d, and a storage capacitor C_{stc}/C_{std} connected between the switching element Q_c/Q_d and the storage electrode line SL.

[0207] The switching element Q_c/Q_d such as a thin film transistor (TFT) is provided on the lower panel **100** and has three terminals: a control terminal connected to a gate line GL; an input terminal connected to a data line DL_a/DL_b; and an output terminal connected to the LC capacitor Cl_{cc}/Cl_{cd}.

[0208] Since the LC capacitor Cl_{cc}/Cl_{cd}, the storage capacitors C_{stc} and C_{std}, and operations of the LCD including the panel assembly shown in FIG. **11** are substantially the same as those described above, further description thereof will be omitted. However, the two pixels PX_c and PX_d forming a pixel PX shown in FIG. **11** are supplied with data voltages at substantially the same time, unlike those shown in FIG. **8**.

[0209] An example of a LC panel assembly shown in FIG. **11** according to an exemplary embodiment of the present invention will be described in detail with reference to FIGS. **12** and **13**.

[0210] FIG. **12** is a layout view of an LC panel assembly according to an exemplary embodiment of the present invention. FIG. **13** is a sectional view of the LC panel assembly shown in FIG. **12** taken along line XIII-XIII.

[0211] Referring to FIGS. **12** and **13**, an LC panel assembly includes a lower panel **100**, an upper panel **200** facing the lower panel **100**, a LC layer **3**, and a pair of polarizers **12** and **22**. Layered structures of the LC panel assembly shown in FIGS. **12** and **13** are substantially the same as those shown in FIGS. **9** and **10**.

[0212] Regarding the lower panel **100**, gate conductors including a gate line **121** and a pair of storage electrode lines **131c** and **131d** are formed on a substrate **110**. The gate line **121** includes first and second gate electrodes **124c** and **124d** and an end portion **129**. The first storage electrode line **131c** includes first and second storage electrodes **137c1** and

137c2, and the second storage electrode line **131d** includes a third storage electrode **137d**. A gate insulating layer **140** is formed on the gate conductors **121**, **131c** and **131d**, and a pair of semiconductor stripes **151** including first and second projections **154c** and **154d** are formed on the gate insulating layer **140**. A pair of ohmic contact stripes **161** including projections **163c** and an ohmic contact **165c** are formed on the semiconductor stripes **151**.

[0213] Data conductors including a pair of first and second data lines **171a** and **171b** and a pair of first and second drain electrodes **175c** and **175d** are formed on the ohmic contacts **161** and **165a**. The first/second data line **171a**/**171b** includes a first/second source electrode **173c**/**173d** and an end portion **179a**/**179b**. The first drain electrode **175c** includes an expansion **177c**, and the second drain electrode **175d** includes an expansion **177d1** and an end portion **177d2**.

[0214] A passivation layer **180** is formed on the data conductors **171a**, **171b**, **175c** and **175d**, the gate insulating layer **140**, and exposed portions of the semiconductor stripes **151**. A plurality of contact holes **181**, **182a**, **182b**, **185c**, **185d1** and **185d2** are provided at the passivation layer **180** and the gate insulating layer **140**. A pixel electrode **191** including first and second subpixel electrodes **191c** and **191d** and a plurality of contact assistants **81**, **82a** and **82b** are formed on the passivation layer **180**. The second subpixel electrode **191d** includes lower and upper electrode parts **191d1** and **191d2**. The first subpixel electrode **191c** has a cutout **91c**, and the second subpixel electrode **191d** has cutouts **92d** and **93d**. An alignment layer **11** is formed on the pixel electrodes **191** and the passivation layer **180**.

[0215] Regarding the upper panel **200**, a light blocking member **220**, a color filter **230**, an overcoat **250**, a common electrode **270** having a plurality of cutouts **71c**, **72d** and **73d**, and an alignment layer **21** are formed on an insulating substrate **210**.

[0216] However, the number of the gate lines **121** in the LC panel assembly shown in FIGS. **12** and **13** is half that in the LC panel assembly shown in FIGS. **9** and **10**, and the number of the data lines **171a** and **171b** in the LC panel assembly shown in FIGS. **12** and **13** is twice that in the LC panel assembly shown in FIGS. **9** and **10**. Furthermore, first and second TFTs Q_c and Q_d coupled to the first and second subpixel electrodes **191c** and **191d** are connected to the same gate line **121** and different data lines **171a** and **171b**.

[0217] The first TFT Q_c is disposed right to the first data line **171a** and the second TFT Q_d is disposed left of the second data line **171b**.

[0218] The semiconductors **154c** and **154d** extend along the data lines **171a** and **171b** and the drain electrodes **175c** and **175d** to form the semiconductor stripes **151**. The semiconductor stripes **151** have almost the same planar shapes as the data conductors **171a**, **171b**, **175c** and **175d** as well as the underlying ohmic contacts **161** and **165c**.

[0219] A method of manufacturing the lower panel, according to an exemplary embodiment of the present invention, simultaneously forms the data conductors **171a**, **171b**, **175c** and **175d**, the semiconductors **151**, and the ohmic contacts **161** and **165c** using a photolithography process.

[0220] A photoresist pattern for the photolithography process has position-dependent thickness, and in particular, it

has first and second portions with decreased thickness. The first portions are located on wire areas that will be occupied by the data conductors **171a**, **171b**, **175c** and **175d** and the second portions are located on channel areas of TFTs **Qc** and **Qd**.

[0221] The position-dependent thickness of the photoresist is obtained by several techniques, for example, by providing translucent areas on the exposure mask as well as light transmitting transparent areas and light blocking opaque areas. The translucent areas may have a slit pattern, a lattice pattern, a thin film(s) with intermediate transmittance or intermediate thickness. When using a slit pattern, the width of the slits or the distance between the slits may be smaller than the resolution of a light exposer used for the photolithography. Another example is to use a reflowable photoresist. Once a photoresist pattern made of a reflowable material is formed by using a normal exposure mask only with transparent areas and opaque areas, it is subject to a reflow process and flows onto areas without the photoresist, thereby forming thin portions.

[0222] As a result, the manufacturing process is simplified by omitting a photolithography step.

[0223] It is to be understood that various features of the LC panel assembly shown in FIGS. **9** and **10** may be applicable to the LC panel assembly shown in FIGS. **12** and **13**.

[0224] Structures of LC panel assemblies according to other exemplary embodiments of the present invention will be described in detail with reference to FIGS. **1**, **2**, **3**, **14**, **15**, **16**, **17** and **18**.

[0225] FIG. **14** is an equivalent circuit diagram of signal lines and a pixel according to an exemplary embodiment of the present invention.

[0226] The LC panel assembly shown in FIG. **14** includes a plurality of signal lines and a plurality of pixels **PX** connected thereto. The signal lines include a plurality of gate lines **GL** and a plurality of data lines **DL**.

[0227] Each pixel **PX** includes a pair of first and second subpixels **PXe** and **PXf** and a coupling capacitor **Ccp** connected between the first subpixel **PXe** and the second subpixel **PXf**.

[0228] The first subpixel **PXe** includes a switching element **Q** connected to one of the gate lines **GL** and one of the data lines **DL**, a first LC capacitor **Clce** coupled to the switching element **Q**, and a storage capacitor **Cste** connected to the switching element **Q**. The second subpixel **PXf** includes a second LC capacitor **Clcf** coupled to the coupling capacitor **Ccp**.

[0229] The switching element **Q** such as a thin film transistor (TFT) is provided on the lower panel **100** and has three terminals: a control terminal connected to a gate line **GL**; an input terminal connected to a data line **DL**; and an output terminal connected to the LC capacitor **Clce**, the storage capacitor **Cste**, and the coupling capacitor **Ccp**.

[0230] The switching element **Q** transmits data voltages from the data line **DL** in response to gate signals from the gate line **GL** to the first LC capacitor **Clce** and the coupling capacitor **Ccp**, and the coupling capacitor **Ccp** converts the magnitude of the data voltage and supplied to the second LC capacitor **Clcf**.

[0231] In an exemplary embodiment of the present invention, the common voltage **Vcom** is applied to the storage capacitor **Cste** and the capacitor **Clce**, **Cste**, **Clcf** or **Ccp** and a voltage **Ve** stored in the first LC capacitor **Clce** and a voltage **Vf** stored in the second LC capacitor **Clcf** satisfies:

$$V_f = V_{es} [C_{cp} / (C_{cp} + C_{lcf})].$$

[0232] Since $C_{cp} / (C_{cp} + C_{lcf})$ is smaller than one, the voltage **Vf** stored in the second LC capacitor **Clcf** is smaller than the voltage **Ve** stored in the first LC capacitor **Clce**. The relation is also satisfied even though the voltage applied to the storage capacitor **Cste** is not the common voltage **Vcom**.

[0233] For example, the desired ratio of the voltages **Ve** and **Vf** can be obtained by adjusting the capacitance of the coupling capacitor **Ccp**.

[0234] Examples of an LC panel assembly shown in FIG. **14** according to exemplary embodiments of the present invention will be described in detail with reference to FIGS. **15-19**.

[0235] FIG. **15** is a layout view of a lower panel for a LC panel assembly according to an exemplary embodiment of the present invention. FIG. **16** is a layout view of an upper panel for a LC panel assembly according to an exemplary embodiment of the present invention. FIG. **17** is a layout view of a LC panel assembly including the lower panel shown in FIG. **15** and the upper panel shown in FIG. **16**. FIG. **18** is a sectional view of the LC panel assembly shown in FIG. **17** taken along line XVIII-XVIII. FIG. **19** is a layout view of a LC panel assembly according to an exemplary embodiment of the present invention.

[0236] Referring to FIGS. **15-19**, a LC panel assembly includes a lower panel **100**, an upper panel **200** facing the lower panel **100**, and a LC layer **3**.

[0237] First, the lower panel **100** will be described.

[0238] A plurality of gate conductors including a plurality of gate lines **121** and a plurality of storage electrode lines **131** are formed on an insulating substrate **110**.

[0239] The gate lines **121** extend substantially in a transverse direction, and include a plurality of gate electrodes **124** extending upward and downward and an end portion **129** having a large area for contact with another layer or an external driving circuit.

[0240] Each of the storage electrode lines **131** extends substantially parallel to the gate lines **121** and is substantially equidistant from two adjacent gate lines **121**. Each of the storage electrodes **131** shown in FIG. **17** includes first type storage electrodes **137e** expanding downward and second type storage electrodes **137f** expanding upward. The first type storage electrodes **137e** and the second type storage electrodes **137f** are alternately arranged. The storage electrodes **131** shown in FIG. **19** include storage electrodes **137e** and **137f** expanding upward and downward.

[0241] A gate insulating layer **140** is formed on the gate conductors **121** and **131**, and a plurality of semiconductor islands **154e** are formed on the gate insulating layer **140**. The semiconductor islands **154** are disposed on the gate electrodes **124**.

[0242] A plurality of pairs of ohmic contact islands **163e** and **165e** are formed on the semiconductor island **154**.

[0243] A plurality of data conductors including a data line 171 and a plurality of drain electrodes 175e and 175f are formed on the ohmic contacts 163e and 165e and the gate insulating layer 140.

[0244] The data lines 171 extend substantially in the longitudinal direction to intersect the gate lines 121 and the storage electrode lines 131. Each of the data lines 171 includes a plurality of curved portions projecting left, and each of the curved portions includes a pair of oblique portions that are connected to each other to form a chevron and make an angle of about 45 degrees with the gate lines 121.

[0245] Each of the data lines 171 includes a plurality of source electrodes 173e extending toward the gate electrodes 124e, and a wide end portion 179.

[0246] The drain electrodes 175e and 175f are separated from the data line 171 and are disposed opposite the source electrodes 173e with respect to the gate electrodes 124. The drain electrodes 175e and 175f include two types of drain electrodes.

[0247] The first type drain electrode 175e includes first and second curved portions 176e and 178 and an expansion 177e. The first curved portion 176e includes a first end partly enclosed by a source electrode 173e and a second end connected to the expansion 177e. The expansion 177e is connected to the first and the second curved portions 176e and 178 and overlaps a first type storage electrode 137e. Each of the first and the second curved portions 176e and 178 includes a pair of oblique portions that are connected to each other to form a chevron or an inequality and make an angle of about 45 degrees with the gate lines 121.

[0248] The second type drain electrode 175f includes only one curved portion 176f and an expansion 177f connected thereto. The curved portion 176f includes an end partly enclosed by a source electrode 173e and curved like an inequality. The expansion 177f overlaps a second type storage electrode 137f.

[0249] A gate electrode 124e, a source electrode 173e, and a drain electrode 175e or 175f along with a semiconductor island 154e form a first/second TFT Q having a channel formed in the semiconductor island 154e disposed between the source electrodes 173e and the drain electrodes 175e or 175f.

[0250] A passivation layer 180 is formed on the data conductors 171, 175e and 175f and the exposed portions of the semiconductor islands 154e.

[0251] The passivation layer 180 has a plurality of contact holes 182 exposing the end portions 179 of the data lines 171, a plurality of contact holes 185e exposing the expansions 177e of the drain electrodes 175e, and a plurality of contact holes 185f exposing the expansions 177f of the drain electrodes 175f. The passivation layer 180 and the gate insulating layer 140 have contact holes 181 exposing the end portions 129 of the gate lines 121.

[0252] A plurality of pixel electrodes 191 and a plurality of contact assistants 81 and 82 are formed on the passivation layer 180.

[0253] Each of the pixel electrodes 191 includes a pair of first and second subpixel electrodes 191e and 191f, and each of the subpixel electrodes 191e and 191f has cutout(s) 91e, 92f and 93f.

[0254] The data lines 171, in particular, the curved portions of the data lines 171 extend along some of the curved edges of the pixel electrodes 191 to be curved. Therefore, the electric field generated between the data lines 171 and the subpixel electrodes 191a and 191b has a horizontal component substantially parallel to the horizontal component of the primary electric field such that the determination of the tilt direction of the LC molecules is enhanced. In addition, the aperture ratio is increased.

[0255] In addition, the storage electrode lines 131 are disposed near the boundaries of the first and the second subpixel electrodes 191a and 191b to cover texture and to increase the aperture ratio.

[0256] The first subpixel electrodes 191e shown in FIG. 19 include portions extending upward or downward onto the storage electrodes 137e and 137f.

[0257] Since other structural features of the pixel 191 are described above with reference to FIG. 3, further description thereof will be omitted.

[0258] The first subpixel electrodes 191e are connected to the drain electrodes 175e and 175f through the contact holes 185e and 185f. The projections of the first subpixel electrodes 191e shown in FIG. 19 is connected to the drain electrodes 175e and 175f through the contact holes 185e and 185f. The curved portions 176f and 178 of the drain electrodes 175e and 175f overlap the second subpixel electrodes 191f to form a coupling capacitor Ccp.

[0259] A first/second subpixel electrode 191e/191f and the common electrode 270 along with a portion of the LC layer 3 disposed therebetween form a first/second LC capacitor Clca/Clcb, which stores applied voltages after the TFT Q turns off.

[0260] The first subpixel electrodes 191e and the drain electrodes 175e connected thereto overlap the storage electrodes 137e and 137f with the gate insulating layer 140 interposed therebetween to form storage capacitors Cste. The storage capacitors Cste enhance the charge storing capacity of the LC capacitors Clce.

[0261] The contact assistants 81 and 82 are connected to the end portions 129 of the gate lines 121 and the end portions 179 of the data lines 171 through the contact holes 181 and 182, respectively. The contact assistants 81 and 82 protect the end portions 129 and 179 and enhance the adhesion between the end portions 129 and 179 and external devices.

[0262] Hereinafter, the upper panel 200 will be described with reference to FIGS. 16-19.

[0263] A light blocking member 220 is formed on an insulating substrate 210 such as transparent glass or plastic. The light blocking member 220 includes transverse portions facing the gate lines 121 on the lower panel 100 and widened portions facing the TFTs Q on the lower panel 100.

[0264] A plurality of color filters 230 are also formed on the substrate 210 and the light blocking member 220 and an overcoat 250 is formed on the color filters 230 and the light blocking member 220. A common electrode 270 having a plurality of cutouts 71e, 72f and 73f is formed on the overcoat 250.

[0265] Since the configurations of the cutouts 71e, 72f and 73f are described above with reference to FIG. 3, further description thereof will be omitted.

[0266] Alignment layers 11 and 21 are formed on inner surfaces of the panels 100 and 200, and polarizers 12 and 22 are provided on outer surfaces of the panels 100 and 200.

[0267] It is to be understood that various features of the LC panel assembly shown in FIGS. 9 and 10 may be applicable to the LC panel assembly shown in FIGS. 15-19.

[0268] Hereinafter, a structure of an LC panel assembly according to an exemplary embodiment of the present invention will be described in detail with reference to FIGS. 1, 2, 3, 20, 21 and 22.

[0269] FIG. 20 is an equivalent circuit diagram of signal lines and a pixel according to an exemplary embodiment of the present invention.

[0270] The LC panel assembly shown in FIG. 20 includes a lower panel 100, an upper panel 200 facing the lower panel 200, and a LC layer 3 disposed between the panels 100 and 200.

[0271] A plurality of signal lines including gate lines GL, data lines DL, and storage electrode lines SL are formed on the lower panel 100. Each pixel includes a switching element Q connected to one of the gate lines GL and one of the data lines DL, a LC capacitor Clc coupled to the switching element Q, and a storage capacitor Cst connected between the switching element Q and the storage electrode line SL.

[0272] The switching element Qc/Qd such as a thin film transistor (TFT) is provided on the lower panel 100 and has three terminals: a control terminal connected to a gate line GL; an input terminal connected to a data line DL; and an output terminal connected to the LC capacitor Clc and the storage capacitor Cst.

[0273] The LC capacitor Clc includes a pixel electrode PE and a common electrode CE provided on an upper panel 200 as two terminals. The LC layer 3 disposed between the electrodes PE and CE functions as dielectric of the LC capacitor Clc. The common electrode CE is supplied with a common voltage Vcom and covers an entire surface of the upper panel 200. The LC layer 3 may have a negative dielectric anisotropy, and LC molecules in the LC layer 3 may be oriented so that longitudinal axes of the LC molecules are perpendicular to the surfaces of the panels 100 and 200 in absence of electric field.

[0274] Since the storage capacitor Cst and the operations of the LCD including the panel assembly shown in FIG. 20 are substantially the same as those described above, further description thereof will be omitted. However, it is noted that a pixel PX is not divided into two subpixels.

[0275] Examples of a LC panel assembly shown in FIG. 20 according to exemplary embodiments of the present invention will be described in detail with reference to FIGS. 21 and 22. FIGS. 21 and 22 are layout views of an LC panel assembly according to exemplary embodiments of the present invention.

[0276] Referring to FIGS. 21 and 22, an LC panel assembly includes a lower panel (not shown), an upper panel (not shown) facing the lower panel, and a LC layer (not shown) disposed between the panels. Layered structures of the LC

panel assembly shown in FIGS. 21 and 22 are substantially the same as those shown in FIGS. 15-19.

[0277] Regarding the lower panel, a plurality of gate conductors including gate lines 121 and storage electrode lines 131 are formed on a substrate (not shown). Each of the gate lines 121 includes gate electrodes 124 and an end portion 129, and the storage electrode line 131 includes storage electrodes 137. A gate insulating layer (not shown) is formed on the gate conductors 121 and 131. A plurality of semiconductor islands 154 are formed on the gate insulating layer, and a plurality of ohmic contacts (not shown) are formed on the semiconductor islands 154.

[0278] A plurality of data conductors including a plurality of data lines 171 and a plurality of drain electrodes 175 are formed on the ohmic contacts and the gate insulating layer. The data lines 171 include a plurality of source electrodes 173 and an end portion 179, and the drain electrodes 175 includes wide end portions 177.

[0279] A passivation layer 180 is formed on the data conductors 171 and 175, the gate insulating layer, and exposed portions of the semiconductor islands 154. A plurality of contact holes 181, 182 and 185 are provided at the passivation layer 180 and the gate insulating layer. A plurality of pixel electrodes 191 including first and second subpixel electrodes 191g and 191h connected to each other and a plurality of contact assistants 81 and 82 are formed on the passivation layer 180. The first subpixel electrode 191g has a cutout 91g, and the second subpixel electrode 191h has cutouts 92h and 93h. An alignment layer (not shown) is formed on the pixel electrodes 191 and the passivation layer 180.

[0280] Regarding the upper panel, a light blocking member (not shown), a plurality of color filters (not shown), an overcoat (not shown), a common electrode having a plurality of cutouts 71g, 72h and 73h, and an alignment layer (not shown) are formed on an insulating substrate (not shown).

[0281] However, in an LC panel assembly shown in FIGS. 21 and 22, a first subpixel electrode 191g and a second subpixel electrode 191h of a pixel electrode 191 are connected to each other, unlike those shown in FIGS. 15-19, and there is no curved portion 178 as shown in FIGS. 15-19. The first subpixel electrode 191g and the second subpixel electrode 191h have substantially equal voltage.

[0282] In comparing the LC panel assembly shown in FIG. 22 with that shown in FIG. 21, the cutouts 91g, 92h and 93h of the pixel electrodes 191 are narrower than the cutouts 71g, 72h and 73h of the common electrode 270, and the distance between a first subpixel electrode 191g and a second subpixel electrode 191h adjacent to each other is smaller than the width of the cutouts 71g, 72h and 73h. The distance or the gap between a first subpixel electrode 191g and a second subpixel electrode 191h may be equal to about 5.5 microns to about 7.5 microns.

[0283] The small width of the cutouts 91g, 92h and 93h and the small distance between the subpixel electrodes 191g and 191h increase the transmitting area of the light to increase the light transmittance.

[0284] Referring to FIG. 22, each of terminal transverse portions of the cutouts 71g, 72h and 73h of the common electrode 270 has a transverse edge overlapping a pixel

electrode **191** and making an angle larger than about 135 degrees with a curved portion of the cutouts **71g**, **72h** and **73h**. Then, the horizontal component of the primary electric field near a transverse edge of the pixel electrode **191** approaches a tilt direction of the LC molecules on a sub-area defined by the terminal transverse portion of the cutouts **71g**, **72h** and **73h**, reducing texture caused by the disorder of the LC molecules there. The width of the cutouts **71g**, **72h** and **73h** may be equal to about 9.5 microns to about 10.5 microns.

[0285] The width of the cutouts **91g**, **92h** and **93h** may be equal to about 8-10 microns. The width of the cutouts **91g**, **92h** and **93h** may be equal to 8 microns to about 9 microns for increasing the light transmitting area to increase the light transmittance.

[0286] The width of a storage electrode **137** shown in FIG. **22** is smaller than the width of the storage electrode **137** shown in FIG. **21**. In addition, the distance between a transverse edge of a storage electrode **137** and an adjacent transverse edge of a terminal transverse portion of the cutouts **71g**, **72h**, **73h** and **92h** disposed on the storage electrode **137** may be equal to or larger than about one micron. In an exemplary embodiment of the present invention, the closest distance L_a from the transverse edge of the storage electrode **137** to the adjacent transverse edge of the terminal transverse portion of the cutouts **71g**, **72h**, **73h** and **92h** is smaller than the farthest distance L_b and equal to or larger than about one micron. This configuration reduces the degradation of the image quality caused by the texture near the cutouts **71g**, **72h**, **73h** and **92h**.

[0287] It is to be understood that various features of the LC panel assembly shown in FIGS. **15-19** may be applicable to the LC panel assembly shown in FIGS. **21** and **22** and vice versa.

[0288] An LCD according to exemplary embodiments of the present invention improves both the visibility and the aperture ratio. In an LCD according to exemplary embodiments of the present invention, the control of the LC molecules is enhanced and the response time and the light transmittance are improved. In addition, the degradation of the image quality caused by the texture is reduced and the balance of colors is easily obtained.

[0289] Although the exemplary embodiments of the present invention have been described in detail with reference to the accompanying drawings for the purpose of illustration, it is to be understood that the inventive processes and apparatus should not be construed as limited thereby. It will be readily apparent to those of reasonable skill in the art that various modifications can be made without departing from the scope of the present invention as defined by the appended claims, with equivalents of the claims to be included therein.

What is claimed is:

1. A liquid crystal display comprising:

a substrate;

a pixel electrode disposed on the substrate and comprising a first subpixel electrode and a second subpixel electrode; and

a common electrode facing the pixel electrode,

wherein the first subpixel electrode comprises a first edge, a second edge disposed opposite the first edge, and two first oblique edges substantially parallel to each other, the first oblique edges making an oblique angle with the first edge and the second edge and meeting the first edge,

the second subpixel electrode comprises a first edge, a second edge disposed opposite the first edge, and two first oblique edges substantially parallel to or substantially perpendicular to the first oblique edges of the first subpixel electrode, the first oblique edges of the second subpixel electrode meeting the first edge of the second subpixel electrode,

the first edge of the first subpixel electrode is adjacent to the first edge of the second subpixel electrode,

a length of the first edge of the first subpixel electrode is different from a length of the first edge of the second subpixel electrode, and

the first oblique edges of the first subpixel electrode are offset from the first oblique edges of the second subpixel electrode.

2. The liquid crystal display of claim 1, further comprising a polarizer having a polarization axis making an angle of about 45 degrees with the first oblique edges of the first subpixel electrode and the first oblique edges of the second subpixel electrode.

3. The liquid crystal display of claim 1, wherein a center of the first edge of the first subpixel electrode is aligned with a center of the first edge of the second subpixel electrode.

4. The liquid crystal display of claim 1, wherein the first subpixel electrode further comprises two second oblique edges meeting the first oblique edges of the first subpixel electrode with making about a right angle.

5. The liquid crystal display of claim 4, wherein the second subpixel electrode further comprises two second oblique edges meeting the first oblique edges of the second subpixel electrode with making about a right angle.

6. The liquid crystal display of claim 5, wherein the first oblique edges of the first subpixel electrode make about a right angle with the first oblique edges of the second subpixel electrode.

7. The liquid crystal display of claim 4, wherein the second subpixel electrode comprises a first electrode part and a second electrode part separated from each other by the first subpixel electrode.

8. The liquid crystal display of claim 7, wherein the first electrode part comprises the first oblique edges of the second subpixel electrode, and the second electrode part comprises two second oblique edges substantially perpendicular to the first oblique edges of the second subpixel electrode.

9. The liquid crystal display of claim 8, wherein the first oblique edges of the first subpixel electrode are substantially parallel to the first oblique edges of the second subpixel electrode.

10. The liquid crystal display of claim 1, wherein a height of the first subpixel electrode is substantially equal to a height of the second subpixel electrode.

11. The liquid crystal display of claim 10, wherein a length of the first edge of the second subpixel electrode is about 1.8 to about 2 times a length of the second edge of the first subpixel electrode.

12. The liquid crystal display of claim 1, wherein a distance between the first subpixel electrode and the second subpixel electrode is equal to about 5.5 microns to about 7.5 microns.

13. The liquid crystal display of claim 1, further comprising a first tilt direction determining member disposed at the common electrode.

14. The liquid crystal display of claim 13, wherein the first tilt direction determining member comprises a first cutout, and wherein the first cutout passes through one of the first and the second subpixel electrodes and comprises an oblique portion extending substantially parallel to the first oblique edges of the first and the second subpixel electrodes.

15. The liquid crystal display of claim 14, wherein a width of the first cutout is equal to about 9.5 microns to about 10.5 microns.

16. The liquid crystal display of claim 14, wherein the first cutout further comprises a terminal portion connected to the oblique portion of the first cutout, overlapping the first or the second edge of the first or the second subpixel electrode, and having an edge making an angle larger than about 135 degrees.

17. The liquid crystal display of claim 14, further comprising a second tilt direction determining member disposed at the second subpixel electrode.

18. The liquid crystal display of claim 17, wherein the second tilt direction determining member comprises a second cutout having an oblique portion bisecting the second subpixel electrode and extending substantially parallel to the first oblique edges of the second subpixel electrode.

19. The liquid crystal display of claim 18, wherein a width of the second cutout is equal to about 8 microns to about 10 microns.

20. The liquid crystal display of claim 18, further comprising a storage electrode disposed on the substrate,

wherein the storage electrode is disposed near a boundary between the first subpixel electrode and the second subpixel electrode adjacent to the first subpixel electrode in a row direction,

the terminal portion of the first cutout overlaps the storage electrode, and

a distance between an edge of the storage electrode and an edge of the terminal portion adjacent to the edge of the storage electrode is equal to or larger than about one micron.

21. The liquid crystal display of claim 18, wherein a distance between the oblique portion of the first cutout and one of the first oblique edges of the first or the second subpixel electrode, and wherein a distance between the oblique portion of the second cutout and the oblique portion of the first cutout are equal to about 25 microns to about 40 microns.

22. The liquid crystal display of claim 18, wherein a distance between the first cutout and the second cutout is shorter than a distance between the first cutout and one of the first oblique edges of the first or the second subpixel electrode.

23. The liquid crystal display of claim 22, wherein the distance between the oblique portion of the second cutout and the oblique portion of the first cutout are equal to about 20 microns to about 30 microns, and wherein the distance between one of the first oblique edges of the second subpixel

electrode and the oblique portion of the first cutout is equal to about 30 microns to about 40 microns.

24. The liquid crystal display of claim 18, wherein the oblique portion of the second cutout meets the oblique portion of the first cutout passing through the first subpixel electrode.

25. The liquid crystal display of claim 1, wherein the first subpixel electrode and the second subpixel electrode have different voltages.

26. The liquid crystal display of claim 25, wherein an area of the first subpixel electrode is smaller than an area of the second subpixel electrode, and wherein the voltage of the first subpixel electrode is higher than the voltage of the second subpixel electrode.

27. The liquid crystal display of claim 26, wherein the area of the second subpixel electrode is about 1.8 to about 2 times the area of the first subpixel electrode.

28. The liquid crystal display of claim 25, wherein the first subpixel electrode and the second subpixel electrode are supplied with different data voltages obtained from a single image information.

29. The liquid crystal display of claim 28, further comprising:

a first thin film transistor coupled to the first subpixel electrode;

a second thin film transistor coupled to the second subpixel electrode;

a first signal line coupled to the first thin film transistor;

a second signal line coupled to the second thin film transistor; and

a third signal line coupled to the first and the second thin film transistors and intersecting the first and the second signal lines.

30. The liquid crystal display of claim 29, wherein the first thin film transistor turns on to transmit a signal from the third signal line in response to a signal from the first signal line, and wherein the second thin film transistor turns on to transmit a signal from the third signal line in response to a signal from the second signal line.

31. The liquid crystal display of claim 29, wherein the first thin film transistor turns on to transmit a signal from the first signal line in response to a signal from the third signal line, and wherein the second thin film transistor turns on to transmit a signal from the second signal line in response to a signal from the third signal line.

32. The liquid crystal display of claim 25, wherein the first subpixel electrode and the second subpixel electrode are capacitively coupled to each other.

33. The liquid crystal display of claim 32, further comprising:

a thin film transistor coupled to the first subpixel electrode;

a first signal line coupled to the thin film transistor; and

a second signal line coupled to the thin film transistor and intersecting the first signal line.

34. The liquid crystal display of claim 1, wherein the first and the second subpixel electrodes are connected to each other.

35. A liquid crystal display comprising:

a pixel electrode comprising a first subpixel electrode and a second subpixel electrode, each of the first and the second subpixel electrodes including two oblique edges disposed opposite each other and substantially parallel to each other, wherein the first and the second subpixel electrodes are arranged in a direction oblique to the oblique edges;

a common electrode disposed opposite the pixel electrode;

a liquid crystal layer disposed between the pixel electrode and the common electrode;

a first tilt direction determining member provided at the second subpixel electrode, extending substantially parallel to the oblique edges, and determining a tilt direction of liquid crystal molecules in the liquid crystal layer; and

a plurality of second tilt direction determining members provided at the common electrode and determining tilt directions of the liquid crystal molecules, each second tilt direction determining member comprising a first portion substantially parallel to the oblique edges and either disposed between the oblique edges or between one of the oblique edge and the first tilt direction determining member,

wherein each of the first and the second subpixel electrodes is divided into a plurality of sub-areas by the first or the second tilt direction determining members and the oblique edges,

the number of the sub-areas in the first subpixel electrode is different from the number of the sub-areas in the second subpixel electrode, and

the oblique edges of the first subpixel electrode are offset from the oblique edges of the second subpixel electrode.

36. The liquid crystal display of claim 35, further comprising a polarizer having a polarization axis making an angle of about 45 degrees with the oblique edges of the first subpixel electrode and the oblique edges of the second subpixel electrode.

37. The liquid crystal display of claim 35, wherein the sub-areas have substantially equal area.

38. The liquid crystal display of claim 35, wherein an area of each of the sub-areas is relatively smaller in relation to a distance of the sub-area from the oblique edges.

39. A liquid crystal display comprising:

a substrate;

a first pixel electrode disposed on the substrate and comprising a first subpixel electrode and a second subpixel electrode;

a second pixel electrode disposed on the substrate and comprising a third subpixel electrode and a fourth subpixel electrode; and

a common electrode disposed opposite the first and the second pixel electrodes,

wherein each of the first and the third subpixel electrodes comprises a first edge, a second edge disposed opposite the first edge, and two first oblique edges substantially

parallel to each other, the first oblique edges making an oblique angle with the first edge and the second edge and meeting the first edge,

each of the second and the fourth subpixel electrodes comprises a first edge, a second edge disposed opposite the first edge, and two first oblique edges substantially parallel to or perpendicular to the first oblique edges of the first and the third subpixel electrodes, the first oblique edges of the second and the fourth subpixel electrode meeting the first edge of the second and the fourth subpixel electrode, respectively,

the first edge of the first subpixel electrode is adjacent to the first edge of the second subpixel electrode,

the first edge of the third subpixel electrode is adjacent to the first edge of the fourth subpixel electrode,

the first edge of the first subpixel electrode has a length different from a length of the first edge of the second subpixel electrode,

a length of the first edge of the third subpixel electrode is different from a length of the first edge of the fourth subpixel electrode,

the first oblique edges of the first subpixel electrode are offset from the first oblique edges of the second subpixel electrode, and

the first oblique edges of the third subpixel electrode are offset from the first oblique edges of the fourth subpixel electrode.

40. The liquid crystal display of claim 39, wherein each of the first to the fourth subpixel electrodes further comprises two second oblique edges meeting the first oblique edges thereof with making about a right angle,

the first oblique edges of the first and the third subpixel electrodes make an angle of about 90 degrees with the first oblique edges of the second and the fourth subpixel electrodes, respectively,

the first and the second oblique edges of the first subpixel electrode are adjacent to the first and the second oblique edges of the third subpixel electrode, respectively,

the first and the second oblique edges of the fourth subpixel electrode are adjacent to the first and the second oblique edges of the second subpixel electrode, respectively,

a center of the first edge of the first subpixel electrode is aligned with a center of the first edge of the second subpixel electrode, and

a center of the first edge of the third subpixel electrode is aligned with a center of the first edge of the fourth subpixel electrode.

41. The liquid crystal display of claim 39, wherein the second subpixel electrode comprises a first electrode part and a second electrode part separated from each other by the first subpixel electrode,

the fourth subpixel electrode comprises a first electrode part and a second electrode part separated from each other by the third subpixel electrode,

each of the first and the third subpixel electrodes further comprises two second oblique edges making about a right angle with the first oblique edges thereof, respectively,

the first electrode part of the second or the fourth subpixel electrode includes the first oblique edges of the second or the fourth subpixel electrode, and the second electrode part of the second or the fourth subpixel electrode includes two second oblique edges making about a right angle with the first oblique edges of the second or the fourth subpixel electrode,

the first oblique edges of the first and the third subpixel electrodes are substantially parallel to the first oblique edges of the second and the fourth subpixel electrodes,

the first oblique edges of the first electrode part of the second subpixel electrode are adjacent to the first oblique edges of the first electrode part of the fourth subpixel electrode, and

the first and the second oblique edges of the first subpixel electrode are adjacent to the first and the second oblique edges of the third subpixel electrode, respectively.

42. The liquid crystal display of claim 39, wherein the first or the second edges of the first to the fourth subpixel electrodes make an angle of about 45 degrees or about 135 degrees with the first or the second oblique edges thereof.

43. The liquid crystal display of claim 39, wherein the first to the fourth subpixel electrodes have substantially the same height.

44. The liquid crystal display of claim 43, wherein a length of the first edges of the second and the third subpixel electrodes is about 1.8 to about 2 times a length of the second edges of the first and the fourth subpixel electrodes.

45. A liquid crystal display comprising:

a substrate;

a pixel electrode disposed on the substrate and comprising a first subpixel electrode and a second subpixel electrode; and

a common electrode facing the pixel electrode,

wherein each of the first and the second subpixel electrodes comprises two curved edges substantially parallel to each other,

the common electrode includes a first cutout,

the first and the second subpixel electrodes include a second cutout, and

a width of the second cutout is greater than a width of the first cutout.

46. The liquid crystal display of claim 45, wherein the width of the second cutout is greater than the width of the first cutout by about 1 micron to about 2 microns.

47. The liquid crystal display of claim 46, wherein the width of the first cutout is equal to about 9.5 microns to about 10.5 microns, and wherein the width of the second cutout is equal to about 8 microns to about 10 microns.

48. The liquid crystal display of claim 45, wherein a distance between the first subpixel electrode and the second subpixel electrode is equal to about 5.5 to about 7.5 microns.

49. The liquid crystal display of claim 45, further comprises a storage electrode formed on the substrate and disposed near a boundary between the first subpixel electrode and the second subpixel electrode,

wherein the first cutout or the second cutout comprises a portion overlapping the storage electrode, and wherein a distance between an edge of the storage electrode and an edge of the overlapping portion of the first cutout or the second cutout is greater than about one micron.

50. The liquid crystal display of claim 49, wherein a width of the overlapping portion of the first cutout or the second cutout becomes narrow as goes to an end thereof.

* * * * *

专利名称(译)	液晶显示器		
公开(公告)号	US20070002253A1	公开(公告)日	2007-01-04
申请号	US11/477644	申请日	2006-06-29
[标]申请(专利权)人(译)	三星电子株式会社		
申请(专利权)人(译)	SAMSUNG ELECTRONICS CO. , LTD.		
当前申请(专利权)人(译)	三星DISPLAY CO. , LTD.		
[标]发明人	KIM HYUN WUK SHIN KYOUNG JU CHANG HAK SUN YOO SEUNG HOO DO HEE WOOK UM YOON SUNG JUNG MEE HYE		
发明人	KIM, HYUN-WUK SHIN, KYOUNG-JU CHANG, HAK-SUN YOO, SEUNG-HOO DO, HEE-WOOK UM, YOON-SUNG JUNG, MEE-HYE		
IPC分类号	G02F1/1343		
CPC分类号	G02F1/133634 G02F2001/134345 G02F1/134309 G02F1/133707		
优先权	1020050059157 2005-07-01 KR 1020050072794 2005-08-09 KR		
其他公开文献	US7656487		
外部链接	Espacenet USPTO		

摘要(译)

液晶显示器包括基板，设置在基板上并包括第一子像素电极和第二子像素电极的像素电极，以及面对像素电极的公共电极。第一子像素电极包括第一边缘，与第一边缘相对设置的第二边缘，以及基本上彼此平行的两个第一倾斜边缘，第一倾斜边缘与第一边缘和第二边缘形成倾斜角度并且与第一边缘相交。第二子像素电极包括第一边缘，与第一边缘相对设置的第二边缘，以及与第一子像素电极的第一倾斜边缘基本平行或基本垂直的两个第一倾斜边缘，第二子像素电极的第一倾斜边缘第二子像素电极的第一边缘。第一子像素电极的第一边缘与第二子像素电极的第一边缘相邻，并且第一子像素电极的第一边缘的长度不同于第二子像素电极的第一边缘的长度。第一子像素电极的第一倾斜边缘从第二子像素电极的第一倾斜边缘偏移。

