



(19) **United States**

(12) **Patent Application Publication** (10) **Pub. No.: US 2006/0221289 A1**

Liu et al. (43) **Pub. Date: Oct. 5, 2006**

(54) **PIXEL ELECTRODE STRUCTURE FOR A LIQUID CRYSTAL DISPLAY WITH A HIGH APERTURE RATIO**

(30) **Foreign Application Priority Data**

Jun. 7, 2002 (TW)..... 91112394

(75) Inventors: **Hsiang-Lung Liu**, Taoyuan Hsien (TW); **Hsu-Ho Wu**, Hsinchu (TW)

Publication Classification

Correspondence Address:
THOMAS, KAYDEN, HOSTEMEYER & RISLEY LLP
100 GALLERIA PARKWAY
SUITE 1750
ATLANTA, GA 30339 (US)

(51) **Int. Cl.**
G02F 1/1343 (2006.01)
(52) **U.S. Cl.** 349/143

(57) **ABSTRACT**

(73) Assignee: **HANNSTAR DISPLAY CORP.**, Taipei (TW)

A pixel electrode structure for a liquid crystal display with a high aperture ratio increases the aperture ratio and eliminates Mura phenomenon. Any two adjacent pixel electrodes are disconnected to each other. Each pixel electrode comprises a first-lengthwise periphery that overlaps a first-adjacent data line to form a first overlapping portion, and a second-lengthwise periphery that overlaps a second-adjacent data line to form a second overlapping portion. The first-lengthwise periphery and the second-lengthwise periphery have an identical triangle-wave profile and are symmetrical to each other. The triangle-wave profile is formed by connecting a plurality of right-angled and equilateral triangles.

(21) Appl. No.: **11/423,546**

(22) Filed: **Jun. 12, 2006**

Related U.S. Application Data

(63) Continuation of application No. 10/873,098, filed on Jun. 21, 2004.

Continuation of application No. 10/351,792, filed on Jan. 27, 2003, now Pat. No. 6,771,345.

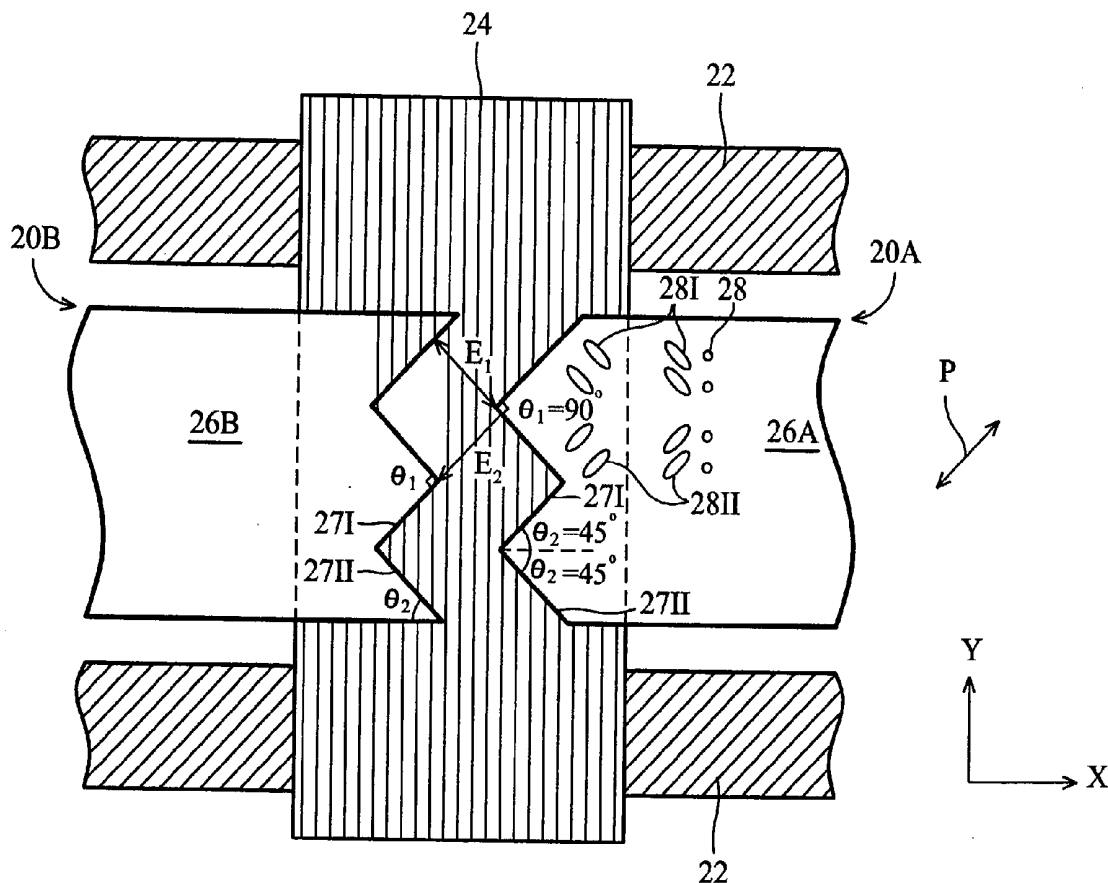

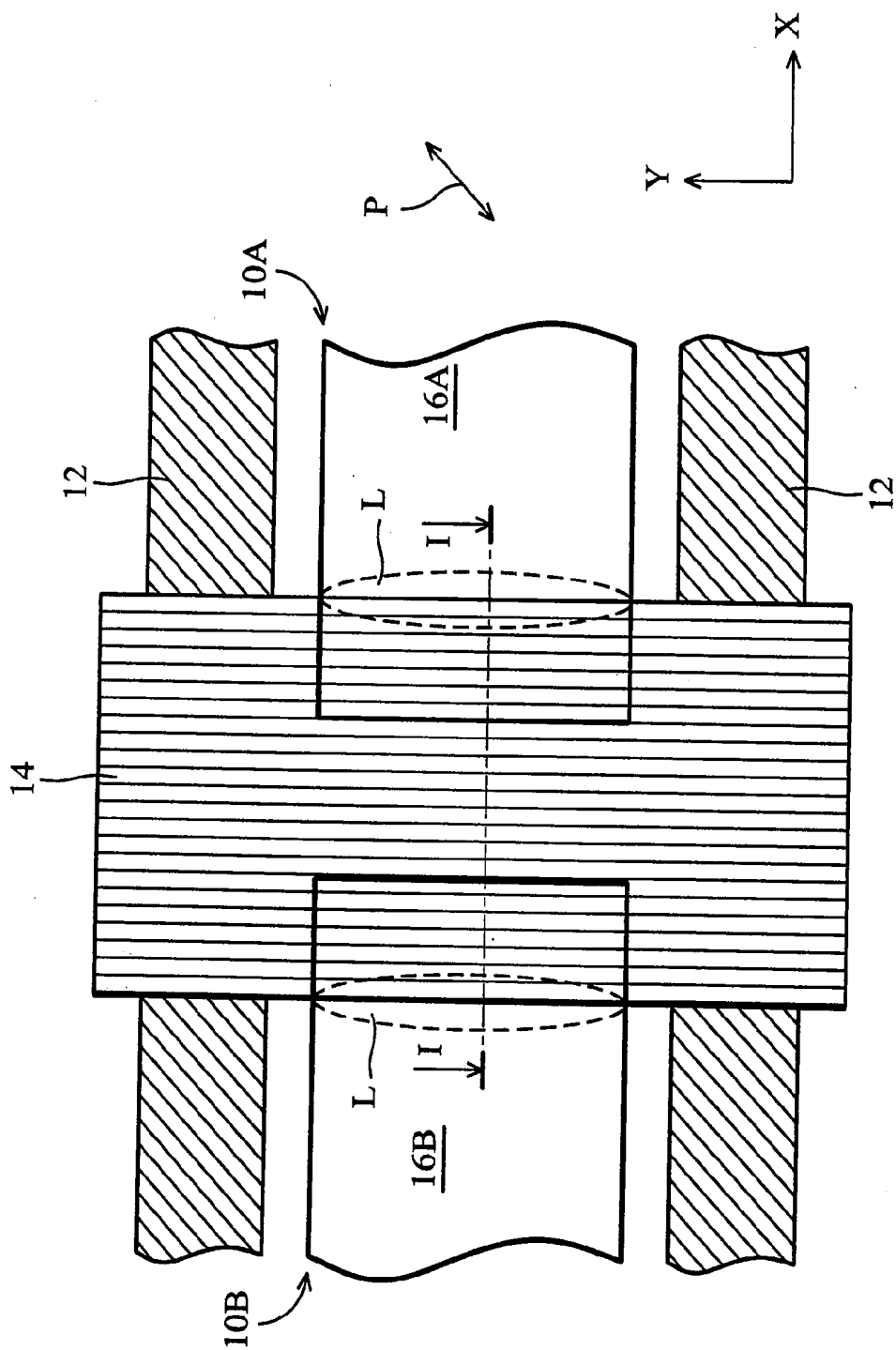

FIG. 1 (PRIOR ART)

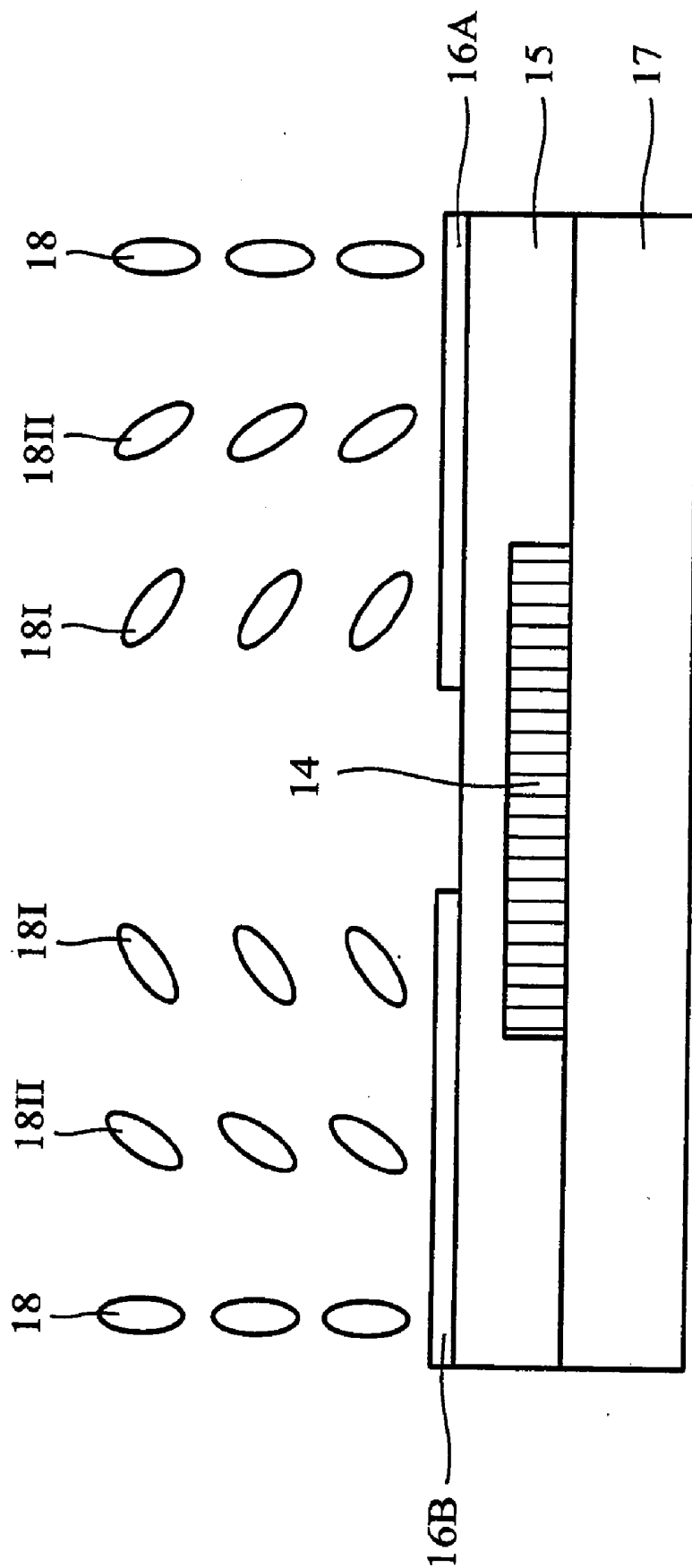

FIG. 2 (PRIOR ART)

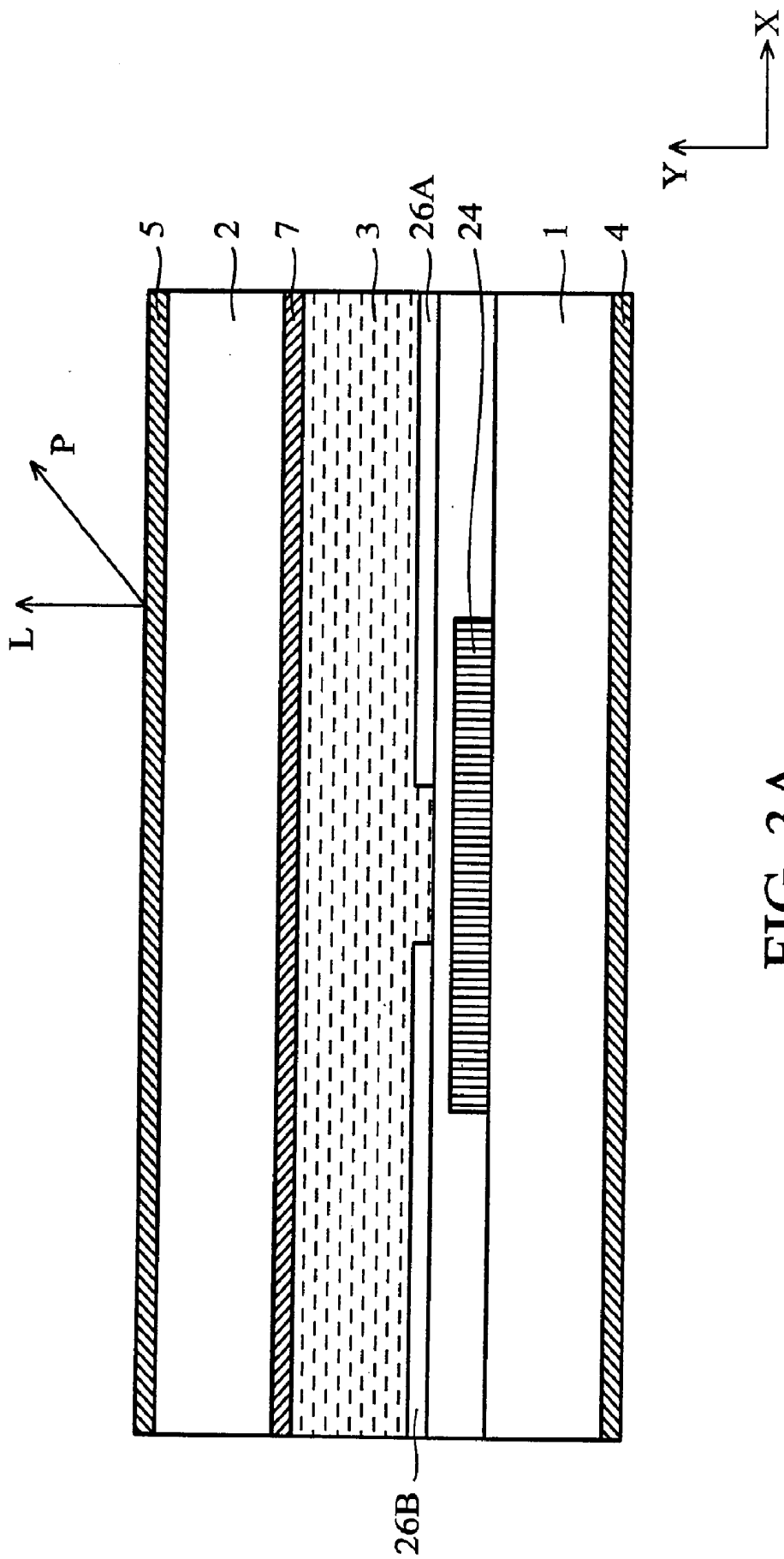

FIG. 3A

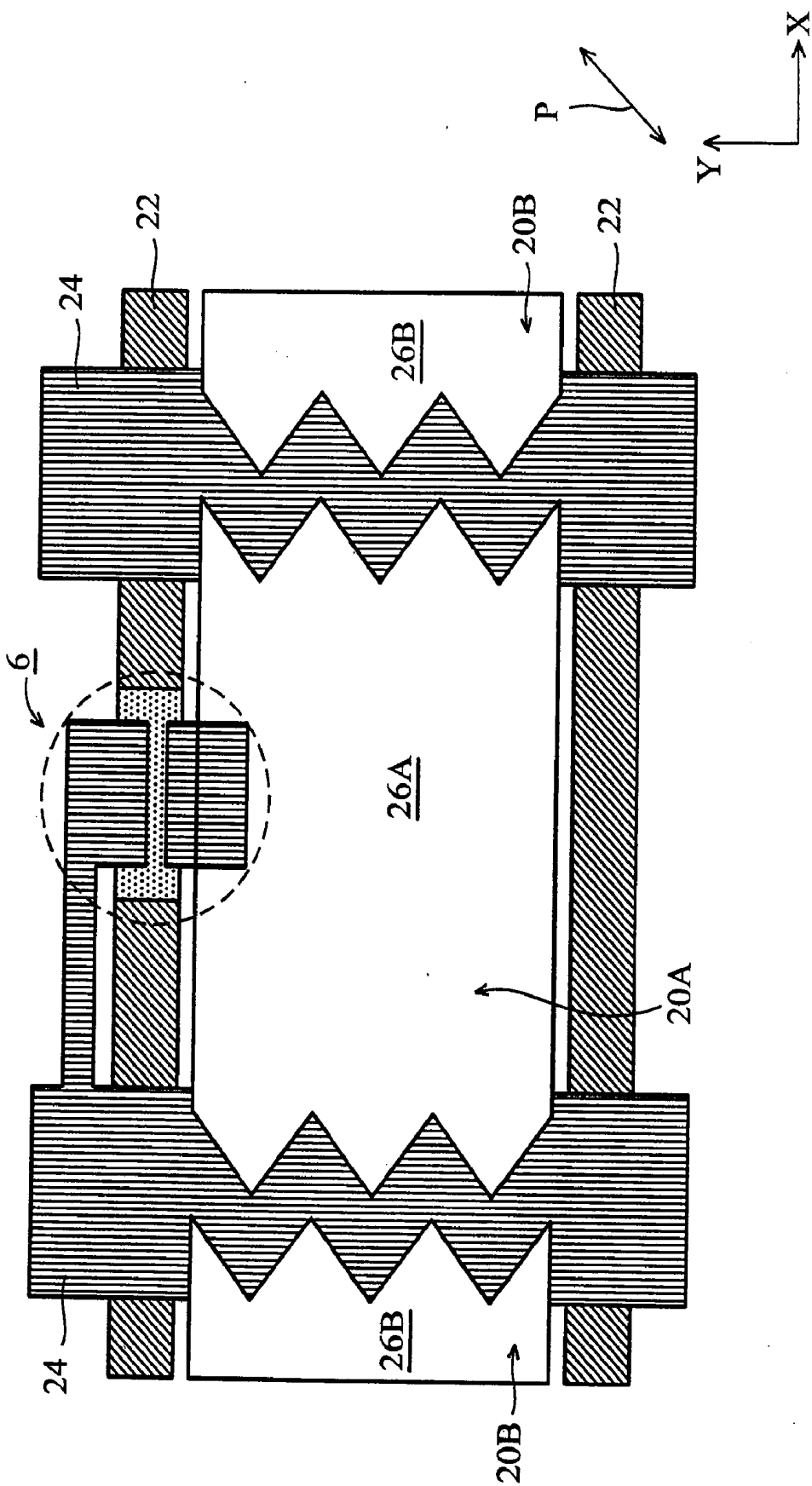

FIG. 3B

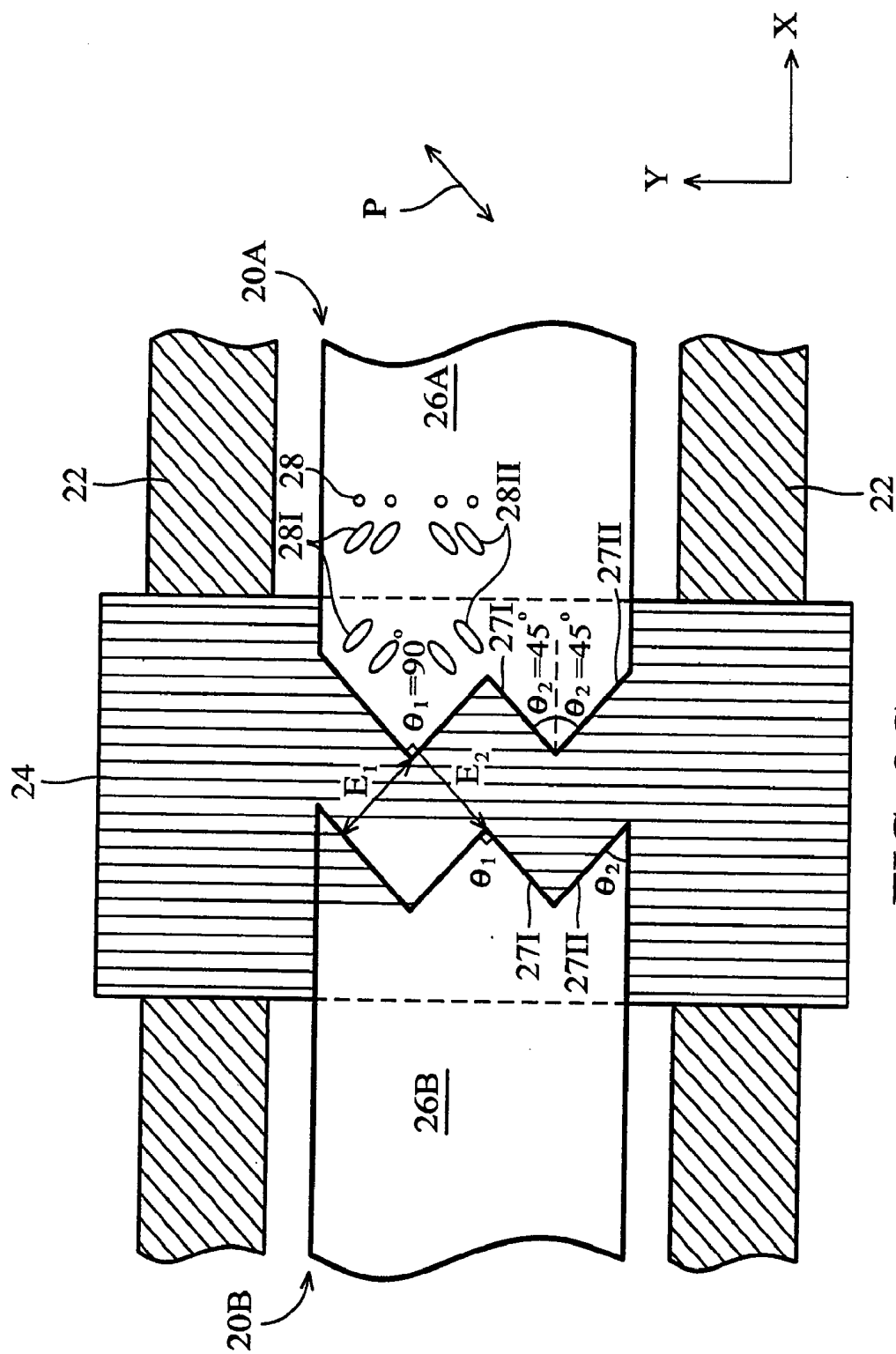

FIG. 3C

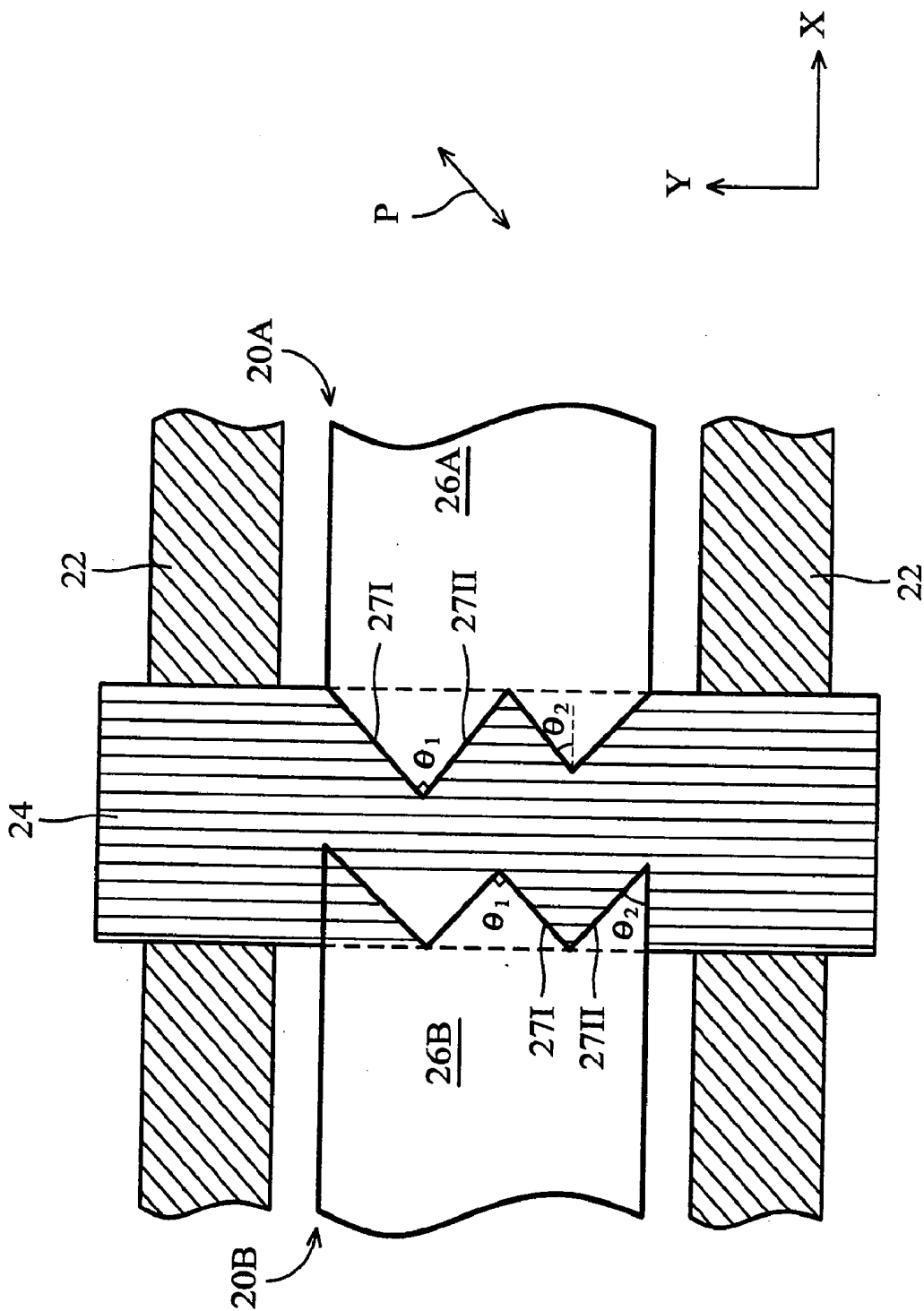

FIG. 4

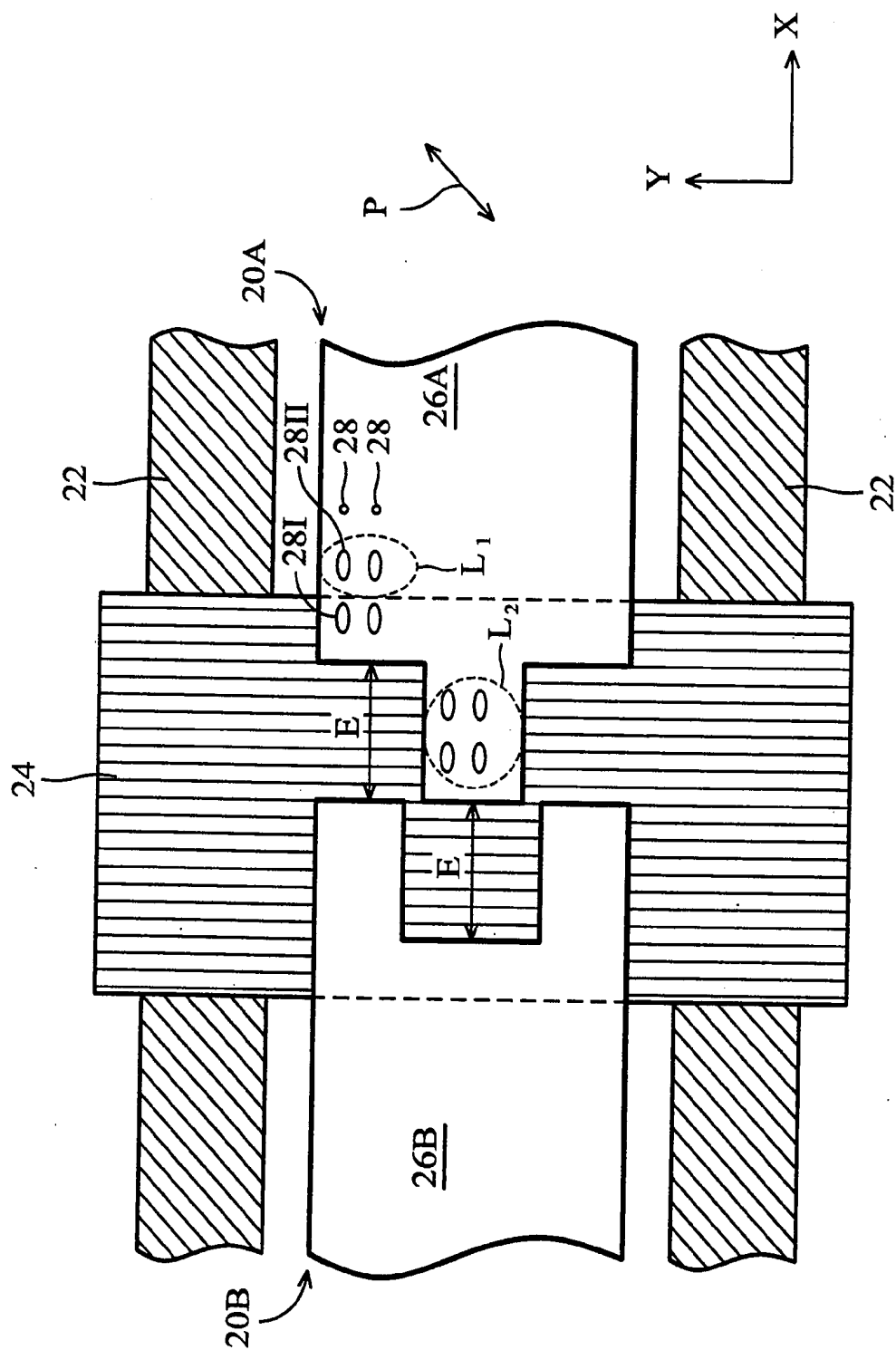

FIG. 5

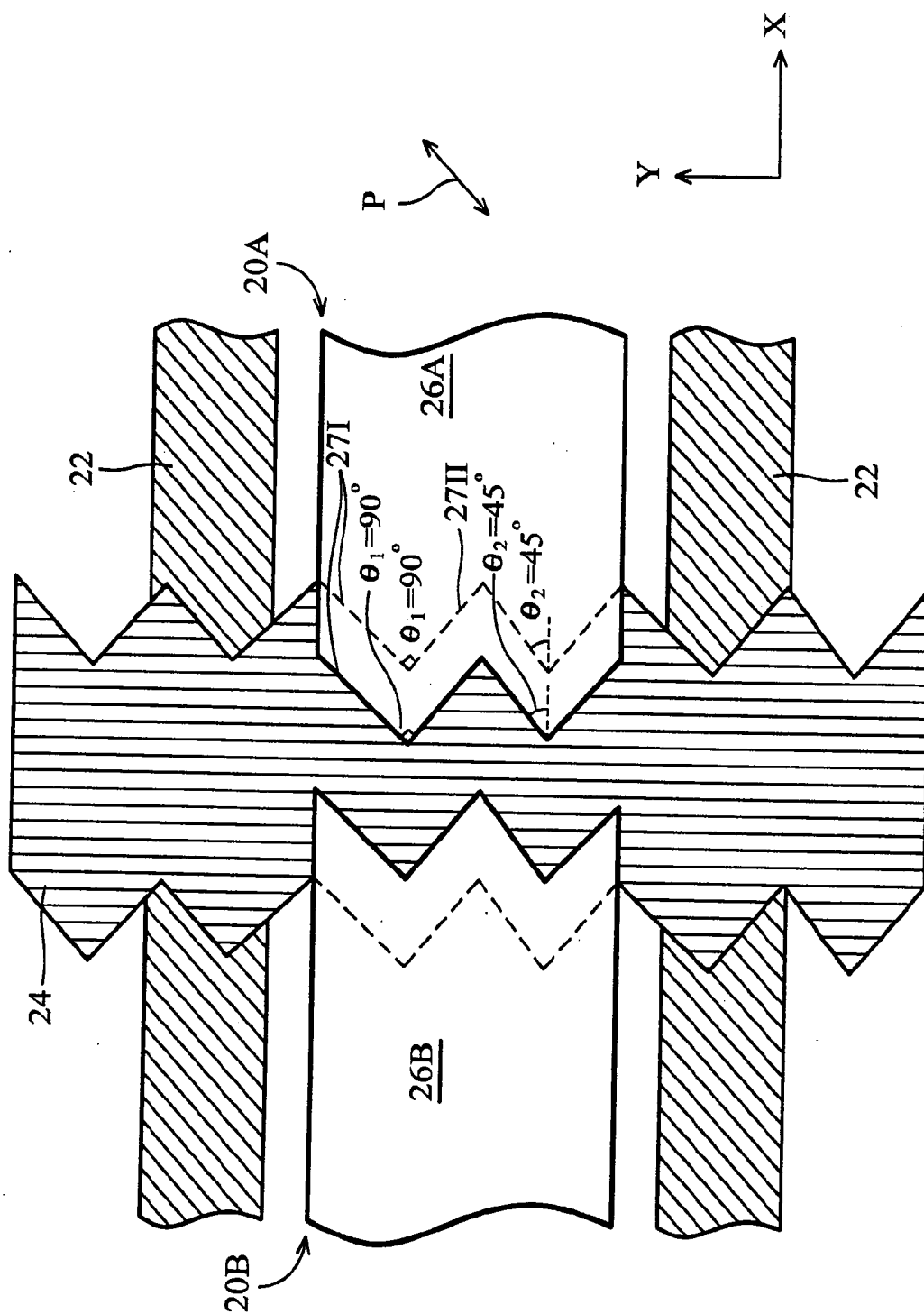

FIG. 6

PIXEL ELECTRODE STRUCTURE FOR A LIQUID CRYSTAL DISPLAY WITH A HIGH APERTURE RATIO

BACKGROUND OF THE INVENTION

[0001] 1. Field of the Invention

[0002] The invention relates to a liquid crystal display (LCD) that has a high aperture ratio (HAR), and more particularly, to a pixel electrode structure for the LCD with HAR.

[0003] 2. Description of the Related Art

[0004] As resolutions of liquid crystal display (LCD) increase, aperture ratio of the LCD becomes more and more insufficient. Recently, color filter on array (COA) technology, has been developed to provide a LCD of high aperture ratio. In the HAR process, the color filter process is integrated with the TFT array process on the same glass substrate, thus the aperture ratio of the TFT-LCD device is increased to effectively improve brightness of the panel, and the step of attachment/alignment between a color filter substrate and a TFT array substrate is omitted to improve yield and decrease process costs. Moreover, in the HAR process, an overlapping portion is formed between a transparent pixel electrode and a data line to decrease the required area of a black matrix (BM) layer, resulting in a higher aperture ratio in the TFT-LCD device.

[0005] FIG. 1 is a top view showing an electrode structure in a pixel of a conventional TFT-LCD device formed using a HAR process. FIG. 2 is a sectional diagram along line I-I of FIG. 1 showing the rotating orientations of liquid crystal molecules in the conventional TFT-LCD device using a HAR process.

[0006] The conventional TFT-LCD device comprises a plurality of traversing gate lines 12 and data lines 14 extending lengthwise to define a plurality of pixels 10 in a matrix, each pixel 10 comprising a pixel electrode 16 and a TFT. Using one data line 14 as the boundary, a first pixel 10A is covered by a first pixel electrode 16A, and a second pixel 10B is covered by a second pixel electrode 16B. Also, the periphery of the first pixel electrode 16A overlaps one side portion of the data line 14, the periphery of the second pixel electrode 16A overlaps another side portion of the data line 14, and a predetermined distance is kept to space the first pixel electrode 16A from the second pixel electrode 16B over the data line 14. Further, an arrow P indicates a light-polarization planar direction on a polarizer, a light-entry direction.

[0007] During a HAR process on a TFT array glass substrate 17, a first metal layer is patterned as the gate lines 12, and then an insulating layer 15 is deposited to cover the gate lines 12 and the glass substrate 17. Next, processes corresponding to TFT are performed on a predetermined area of the gate line 12, and a second metal layer is patterned as the data lines 14. Next, a transparent conductive layer is patterned as the first pixel electrode 16A and the second pixel electrode 16B.

[0008] In a case using TN-type (twisted nematic type) LCD, when an extra voltage exceeds a critical value, the liquid crystal molecules 18 originally parallel to the alignment film are rotated to become perpendicular to the align-

ment layer in accordance with the magnitude of the lengthwise electric field. However, a transverse electric field is generated between the periphery of the first pixel electrode 16A and the periphery or the second pixel electrode 16B, thus the inclined directions of the liquid crystal molecules 18I and 18II near the periphery of the pixel electrodes 16A and 16B are influenced by the lengthwise and transverse electric field. Also, when an included angle between the arrow P (a light-polarization planar direction on a polarizer) and the long-axis direction of the liquid crystal molecule 18I is 45°, an ellipsoidal polarized light caused by birefringence effect may pass an analyzer perpendicular to the polarizer to result in light leakage. With regard to the rotating orientation of the liquid crystal molecules 18II over the sidewall of the data line 14, however, a Mura phenomenon occurs, manifesting as non-uniform color difference, to form a light leakage area L.

[0009] In another attempt to solve the above-described problems, the width of the data line 14 is increased to shield the light leakage area L, but this decreases the aperture ratio of the TFT-LCD device.

SUMMARY OF THE INVENTION

[0010] Accordingly, an object of the invention is to provide a pixel electrode structure in an LCD to increase the aperture ratio and eliminate Mura phenomenon near the overlapping portion between the pixel electrode and the data line.

[0011] To achieve these and other aims, the invention provides a pixel electrode structure of a liquid crystal display with a high aperture ratio. A first substrate and a second substrate are disposed parallel to each other, such that an internal space is formed between the interior surface of the first substrate and the interior surface of the second substrate. A liquid crystal layer is formed in the internal space. At least one polarizer is formed on the exterior surface of the first substrate or the exterior surface of the second substrate. A plurality of parallel gate lines is transversely formed on the interior surface of the first substrate. A plurality of data lines parallel and extends lengthwise on the interior surface of the first substrate. A plurality of pixels is defined by the gate lines and the data lines in a matrix, in which each pixel comprises at least one TFT formed on the interior surface of the first substrate and near the intersection of the gate line and the data line, a common electrode on the interior surface of the second substrate, covering the pixel, and a pixel electrode on the interior surface of the first substrate, covering the pixel.

[0012] In one preferred embodiment, no two adjacent pixel electrodes are connected to each other. Each pixel electrode comprises a first-lengthwise periphery that overlaps a first-adjacent data line to form a first overlapping portion, and a second-lengthwise periphery that overlaps a second-adjacent data line to form a second overlapping portion. The first-lengthwise periphery and the second-lengthwise periphery have an identical triangle-wave profile and are symmetrical to each other. The triangle-wave profile is formed by connecting a plurality of right-angled and equilateral triangles.

[0013] In another preferred embodiment, no two adjacent pixel electrodes are connected to each other. Each pixel electrode comprises a first-lengthwise periphery that over-

laps a first-adjacent data line to form a first overlapping portion, and a second-lengthwise periphery that overlaps a second-adjacent data line to form a second overlapping portion. The first-lengthwise periphery and the second-lengthwise periphery have an identical square-wave profile, and the square-wave profile is formed by connecting a square protrusion and a square indentation in sequence. The square protrusion of the first-lengthwise periphery corresponds in position to the square indentation of the second-lengthwise periphery, and the square indentation of the first-lengthwise periphery corresponds in position to the square protrusion of the second-lengthwise periphery.

DESCRIPTION OF THE DRAWINGS

[0014] For a better understanding of the present invention, reference is made to a detailed description to be read in conjunction with the accompanying drawings, in which:

[0015] **FIG. 1** is a top view showing an electrode structure in a pixel of a conventional TFT-LCD device with high aperture ratio.

[0016] **FIG. 2** is a sectional diagram along line I-I of **FIG. 1** showing the rotating orientations of liquid crystal molecules in the conventional TFT-LCD device with high aperture ratio.

[0017] **FIG. 3A** is a sectional diagram of an electrode structure in a pixel of a TFT-LCD device according to the first embodiment of the present invention.

[0018] **FIGS. 3B and 3C** are top views of an electrode structure in a pixel of a TFT-LCD device according to the first embodiment of the present invention.

[0019] **FIG. 4** is a view of an electrode structure in a pixel of a TFT-LCD device according to the second embodiment of the present invention.

[0020] **FIG. 5** is a view of an electrode structure in a pixel of a TFT-LCD device according to the third embodiment of the present invention.

[0021] **FIG. 6** is a view of an electrode structure in a pixel of a TFT-LCD device according to the fourth embodiment of the present invention.

DETAILED DESCRIPTION OF THE INVENTION

First Embodiment

[0022] A first embodiment of the present invention is now described with reference to **FIGS. 3A through 3C**. **FIG. 3A** is a sectional diagram of an electrode structure in a pixel of a TFT-LCD device according to the first embodiment of the present invention. **FIGS. 3B and 3C** are top views of an electrode structure in a pixel of a TFT-LCD device according to the first embodiment of the present invention.

[0023] In **FIG. 3A**, the TFT-LCD device comprises a lower substrate **1** and an upper substrate **2** parallel to each other, and a liquid crystal layer **3** in the internal space between the lower substrate **1** and the upper substrate **2**. A lower polarizer **4** is formed on the exterior surface of the lower substrate **1**, an upper polarizer **5** is formed on the exterior surface of the upper substrate **2**, and a common electrode **7** is formed on the interior surface of the upper

substrate **2**. An arrow **L** indicates a light-incident direction, and an arrow **P** indicates a light-entry direction (a light-polarization planar direction of the polarizer **4** and **5**). The included angle between the arrow **P** and the X axis is 45° .

[0024] In **FIGS. 3B and 3C**, on the interior surface of the lower substrate **1**, a plurality of transverse-extending gate lines **22** and a plurality of lengthwise-extending data lines **24** are patterned to define a plurality of pixels **20** in a matrix. Each of the pixels **20** comprises a pixel electrode **26** and a TFT **6**. Using one data line **24** as the boundary, a first pixel area **20A** is covered by a first pixel electrode **26A**, and a second pixel area **20B** is covered by a second pixel electrode **26B**. Also, the periphery of the first pixel electrode **26A** overlaps one side portion of the data line **24**, the periphery of the second pixel electrode **26A** overlaps another side portion of the data line **24**, and a predetermined distance is kept to space the first pixel electrode **26A** from the second pixel electrode **26B** over the data line **24**.

[0025] The first key feature of the first embodiment is that the periphery of the pixel electrode is a triangle-wave profile. Particularly, within one overlapping portion between the first pixel electrode **26A** and the data line **24**, the periphery of the first pixel electrode **26A** is a triangle-wave profile. Similarly, within the other overlapping portion between the second pixel electrode **26B** and the data line **24**, and the periphery of the second pixel electrode **26B** is a triangle-wave profile.

[0026] Preferably, in **FIG. 3C**, the triangle-wave profile is formed by connecting a plurality of right-angled and equilateral triangles. For example, each triangle constitutes a first hypotenuse **27I** (upper right toward lower left), a right angle θ_1 , and a second hypotenuse **27II** (upper left toward lower right). Thus, the angle θ_1 at the protruding portion of the triangle-wave profile is 90° , the included angle θ_2 between the first hypotenuse **27I** and the X axis is 45° , and the included angle θ_2 between the second hypotenuse **27II** and the X axis is 45° . Also, the first hypotenuse **27I** of the first pixel electrode **26A** is parallel to the first hypotenuse **27I** of the second pixel electrode **26B**, and the second hypotenuse **27II** of the first pixel electrode **26A** is parallel to the second hypotenuse **27II** of the second pixel electrode **26B**.

[0027] The second key feature of the first embodiment is that the overlapping portion between the pixel electrode **26** and the data line **24** is larger than the total area of the triangles. Preferably, the width of the data line **24** is about $10\ \mu\text{m}$.

[0028] In a case using TN-type (twisted nematic type) LCD with a parallel-treatment alignment film, when an extra voltage exceeds a critical value, the liquid crystal molecules **28** originally parallel to the alignment film are rotated to become perpendicular to the alignment layer in accordance with the magnitude of the lengthwise electric field. With regard to the rotating orientation of the liquid crystal molecules **28I** and **28II** near the overlapping portion between the data line **24** and the periphery of the first pixel electrode **26A**, a transverse electric field generated between the periphery of the first pixel electrode **26A** and the periphery of the second pixel electrode **26B** is influenced by the triangle-wave profile so as to incline. For example, an arrow E_x indicates a first-inclined electric field generated between the first hypotenuse **27I** of the first pixel electrode **26A** and the first hypotenuse **27I** of the second pixel electrode **26B**.

An arrow E_2 indicates a second-inclined electric field generated between the second hypotenuse 27II of the first pixel electrode 26A and the second hypotenuse 27II of the second pixel electrode 26B. Therefore, the first liquid crystal molecule 28I rotates in the direction of the arrow E_1 , and the second liquid crystal molecule 28II rotates in the direction of the arrow E_2 .

[0029] Concerning the light-polarization planar direction on the polarizer shown by the arrow P, an included angle between the arrow P and the long-axis direction of the first liquid crystal molecule 28I is 90° , and the long-axis direction of the second liquid crystal molecule 28II is parallel to the arrow P. This avoids birefringence effect, that is, no ellipsoidal polarized light passes an analyzer. Thus, Mura phenomenon does not occur near the boundary of the data line 24, eliminating light leakage.

[0030] The rotating orientations of liquid crystal molecules near the overlapping portion between the data line 24 and the periphery of the second pixel electrode 26B are similar to the above-described phenomenon, with no need for further description.

Second Embodiment

[0031] FIG. 4 is a view of an electrode structure in a pixel of a TFT-LCD device according to the second embodiment of the present invention. Most of the electrode structure in the second embodiment is similar to the first embodiment, and the identical parts are omitted with no need for further description. The difference is that the width of the data line 24 is reduced to make the area of the overlapping portion equal to the total area of the triangles. This can achieve the same advantages as described in the first embodiment. Also, by reducing the width of the data line 24 to achieve 3–10 μm , the aperture ratio of the TFT-LCD device is further improved.

Third Embodiment

[0032] FIG. 5 is a view of an electrode structure in a pixel of a TFT-LCD device according to the third embodiment of the present invention. Most of the electrode structure in the third embodiment is similar to the first embodiment, and the identical parts are omitted with no need for further description. The difference is that the periphery of the first pixel electrode 26A is a square-wave profile, and the periphery of the second pixel electrode 26B is a square-wave profile. The square-wave profile is formed by connecting a square protrusion and a square indentation in sequence. Particularly, the square protrusions of the first pixel electrode 26A correspond in position to the square indentations of the second pixel electrode 26B, and the square indentations of the first pixel electrode 26A correspond in position to the square protrusions of the second pixel electrode 26B.

[0033] In a case using TN-type (twisted nematic type) LCD with a parallel-treatment alignment film, when an extra voltage exceeds a critical value, the liquid crystal molecules 28 originally parallel to the alignment film are rotated to become perpendicular to the alignment layer in accordance with the magnitude of the lengthwise electric field. With regard to the rotating orientation of the liquid crystal molecules 28I and 28II near the overlapping portion between the data line 24 and the periphery of the first pixel electrode 26A, a transverse electric field, as shown by an arrow E, is

generated between the periphery of the first pixel electrode 26A and the periphery of the second pixel electrode 26B. Therefore, the rotating orientations of the liquid crystal molecules 28I and 28II are influenced by the transverse electric field E and the lengthwise electric field.

[0034] Concerning a light-polarization planar direction on the polarizer as shown by the arrow P, when an included angle between the arrow P and the long-axis direction of the liquid crystal molecule 28I or 28II is 45° , an ellipsoidal polarized light caused by birefringence effect may pass an analyzer to cause Mura phenomenon, resulting in a first light leakage area L_1 near the square indentation and a second leakage area L_2 near the square protrusion. However, since the data line 24 shields the second leakage area L_2 , Mura phenomenon is eliminated.

[0035] The rotating orientations of liquid crystal molecules over the overlapping portion between the data line 24 and the periphery of the second pixel electrode 26B is similar to the above-described phenomenon with no need for further description.

Fourth Embodiment

[0036] FIG. 6 is a view of an electrode structure in a pixel of a TFT-LCD device according to the fourth embodiment of the present invention. Most of the electrode structure in the fourth embodiment is similar to the first embodiment, and the identical parts are omitted with no need for further description. The difference is that each sidewall of the data line 24 is a triangle-wave profile; with the features of the triangle-wave profile the same as the first pixel electrode 26A and the second pixel electrode 26B. Preferably, the triangle-wave profile is formed by connecting a plurality of right-angled and equilateral triangles. Each triangle constitutes a first hypotenuse 27I (upper right toward lower left), a right angle, and a second hypotenuse 27II (upper left toward lower right). Thus, the angle θ_1 at the protruding portion of the triangle-wave profile is 90° , the included angle θ_2 between the first hypotenuse 27I and X axis is 45° , and the included angle θ_2 between the second hypotenuse 27II and X axis is 45° .

[0037] Also, the first hypotenuse 27I of the data line 24 is parallel to the first hypotenuse 27I of the first pixel electrode 26A and parallel to the first hypotenuse 27I of the second pixel electrode 26B, and the second hypotenuse 27II of the data line 24 is parallel to the second hypotenuse 27II of the first pixel electrode 26A and parallel to the second hypotenuse 27II of the second pixel electrode 26B.

[0038] While the invention has been described by way of example and in terms of the preferred embodiments, it is to be understood that the invention is not limited to the disclosed embodiments. To the contrary, it is intended to cover various modifications and similar arrangements (as would be apparent to those skilled in the art). Therefore, the scope of the appended claims should be accorded the broadest interpretation so as to encompass all such modifications and similar arrangements.

1-14. (canceled)

15. A liquid crystal display, comprising:

a first substrate and a second substrate disposed opposite each other with a liquid crystal layer interposed therebetween;

a plurality of pixels defined by crossing gate and data lines formed on the first substrate; and

a pixel electrode having a first wave-shaped edge portion formed over the first substrate in each pixel, wherein the pixel electrode overlaps a portion of the data line to form an overlapping portion;

wherein the area of the overlapping portion is equal to or larger than the area of the first wave-shaped edge portion.

16. The liquid crystal display as claimed in claim 15, wherein the first wave-shaped edge portion has a square-wave profile.

17. The liquid crystal display as claimed in claim 16, wherein the square-wave profile is formed by connecting a square protrusion and a square indentation in sequence.

18. The liquid crystal display as claimed in claim 15, wherein the data line has a second wave-shaped edge portion.

19. The liquid crystal display as claimed in claim 18, wherein the second wave-shaped edge portion corresponds to the first wave-shaped edge portion.

20. The liquid crystal display as claimed in claim 15, further comprising at least one polarizer disposed on an exterior of the first or second substrate.

21. The liquid crystal display as claimed in claim 20, wherein an included angle between a light-polarization planar direction of the polarizer and an X axis is 45 degree.

22. The liquid crystal display as claimed in claim 15, wherein the liquid crystal layer comprises TN-type liquid crystal molecules.

23. A liquid crystal display, comprising:

crossing gate and data lines formed on a substrate; and

a plurality of pixel electrodes formed in an area defined by the gate and data lines, wherein two adjacent pixel electrodes are disconnected to each other;

wherein each pixel electrode comprises a first wave-shaped edge portion overlapped with a portion of the data line;

wherein the data line has a second wave-shaped edge portion;

wherein the second wave-shaped edge portion corresponds to the first wave-shaped edge portion.

24. The liquid crystal display as claimed in claim 23, wherein the first wave-shaped edge portion has a square-wave profile formed by connecting a square protrusion and a square indentation in sequence.

25. The liquid crystal display as claimed in claim 23, wherein the first wave-shaped edge portions of adjacent pixel electrode are engaged with each other.

* * * * *

专利名称(译)	用于具有高孔径比的液晶显示器的像素电极结构		
公开(公告)号	US20060221289A1	公开(公告)日	2006-10-05
申请号	US11/423546	申请日	2006-06-12
[标]申请(专利权)人(译)	瀚宇彩晶股份有限公司		
申请(专利权)人(译)	瀚宇彩晶股份有限公司.		
当前申请(专利权)人(译)	瀚宇彩晶股份有限公司.		
[标]发明人	LIU HSIANG LUNG WU HSU HO		
发明人	LIU, HSIANG-LUNG WU, HSU-HO		
IPC分类号	G02F1/1343 G02F1/1335 G02F1/1362		
CPC分类号	G02F1/133512 G02F1/134336 G02F1/136209 G02F2201/40 G02F1/1396 G02F2201/122 G02F2201/123 G02F1/136286		
优先权	091112394 2002-06-07 TW		
其他公开文献	US7440062		
外部链接	Espacenet USPTO		

摘要(译)

用于具有高孔径比的液晶显示器的像素电极结构增加了孔径比并消除了Mura现象。任何两个相邻的像素电极彼此断开。每个像素电极包括与第一相邻数据线重叠以形成第一重叠部分的第一纵向外围，以及与第二相邻数据线重叠以形成第二重叠部分的第二纵向外围。第一纵向周边和第二纵向周边具有相同的三角波轮廓并且彼此对称。通过连接多个直角和等边三角形形成三角波轮廓。

