



US007460203B2

(12) **United States Patent**
Kim

(10) **Patent No.:** **US 7,460,203 B2**
(45) **Date of Patent:** **Dec. 2, 2008**

(54) **LIQUID CRYSTAL DISPLAY DEVICE**

(75) Inventor: **Seok Su Kim**, Gyeongsangbuk-do (KR)

(73) Assignee: **LG.Philips LCD Co., Ltd**, Seoul (KR)

(*) Notice: Subject to any disclaimer, the term of this patent is extended or adjusted under 35 U.S.C. 154(b) by 387 days.

(21) Appl. No.: **11/475,910**

(22) Filed: **Jun. 28, 2006**

(65) **Prior Publication Data**

US 2007/0085960 A1 Apr. 19, 2007

(30) **Foreign Application Priority Data**

Oct. 14, 2005 (KR) 10-2005-0097130

(51) **Int. Cl.**
G02F 1/1345 (2006.01)

(52) **U.S. Cl.** 349/149; 349/139; 349/152

(58) **Field of Classification Search** 349/139,
349/141, 143-152

See application file for complete search history.

(56) **References Cited**

U.S. PATENT DOCUMENTS

2005/0140632 A1* 6/2005 Tsuda et al. 345/92
2007/0182909 A1* 8/2007 Kim et al. 349/149

* cited by examiner

Primary Examiner—Hemang Sanghavi

(74) *Attorney, Agent, or Firm*—Holland & Knight LLP

(57) **ABSTRACT**

A liquid crystal display device with a liquid crystal layer disposed between first and second substrates in which the first substrate is divided into an active region and a pad region outside the active region that includes: gate lines and data lines crossing each other to define pixels in the active region of the first substrate; a thin film transistor and a pixel electrode in each of the pixels; common lines parallel to the gate lines in the active region; gate pads in the pad region, the gate pads electrically connected to the gate lines; data pads in the pad region, the data pads electrically connected to the data lines; a common electrode along an edge of the active region and electrically connected with the common lines; an insulation film over the common electrode; and a distortion preventing electrode overlapping the common electrode with the insulation film interposed therebetween for creating a capacitance.

39 Claims, 12 Drawing Sheets

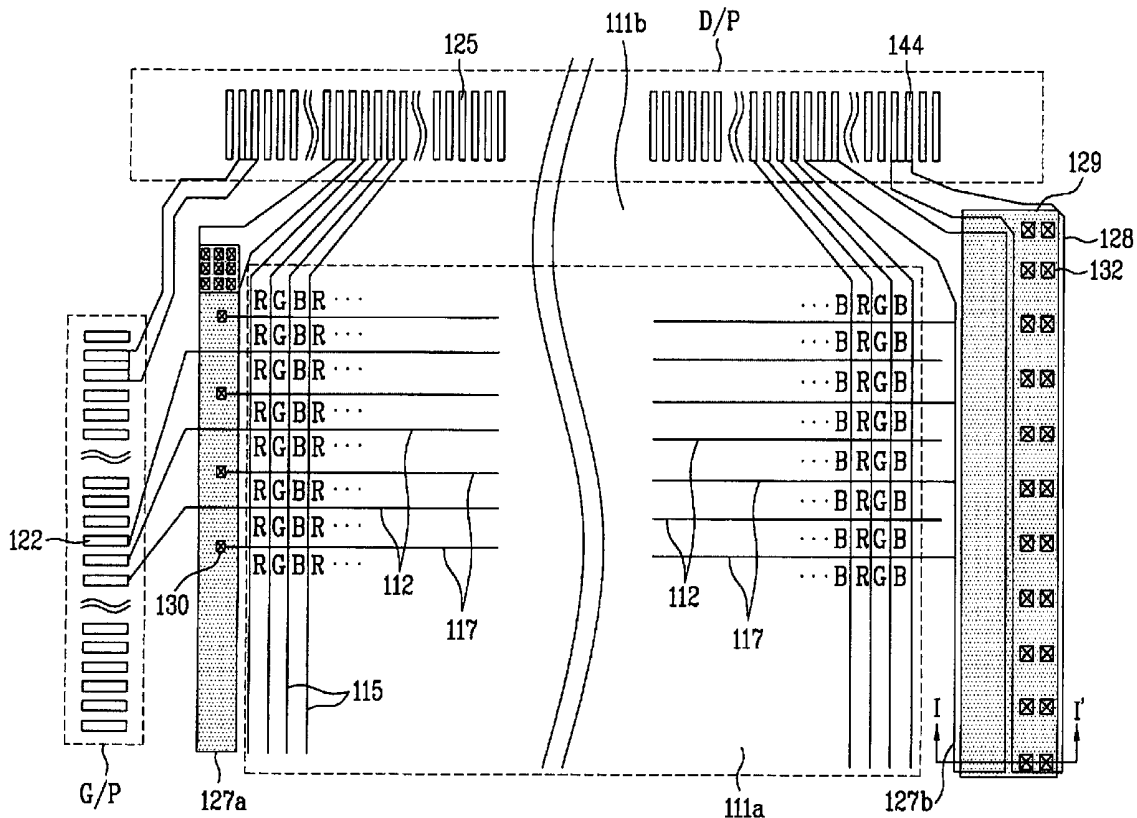

FIG. 1
Related Art

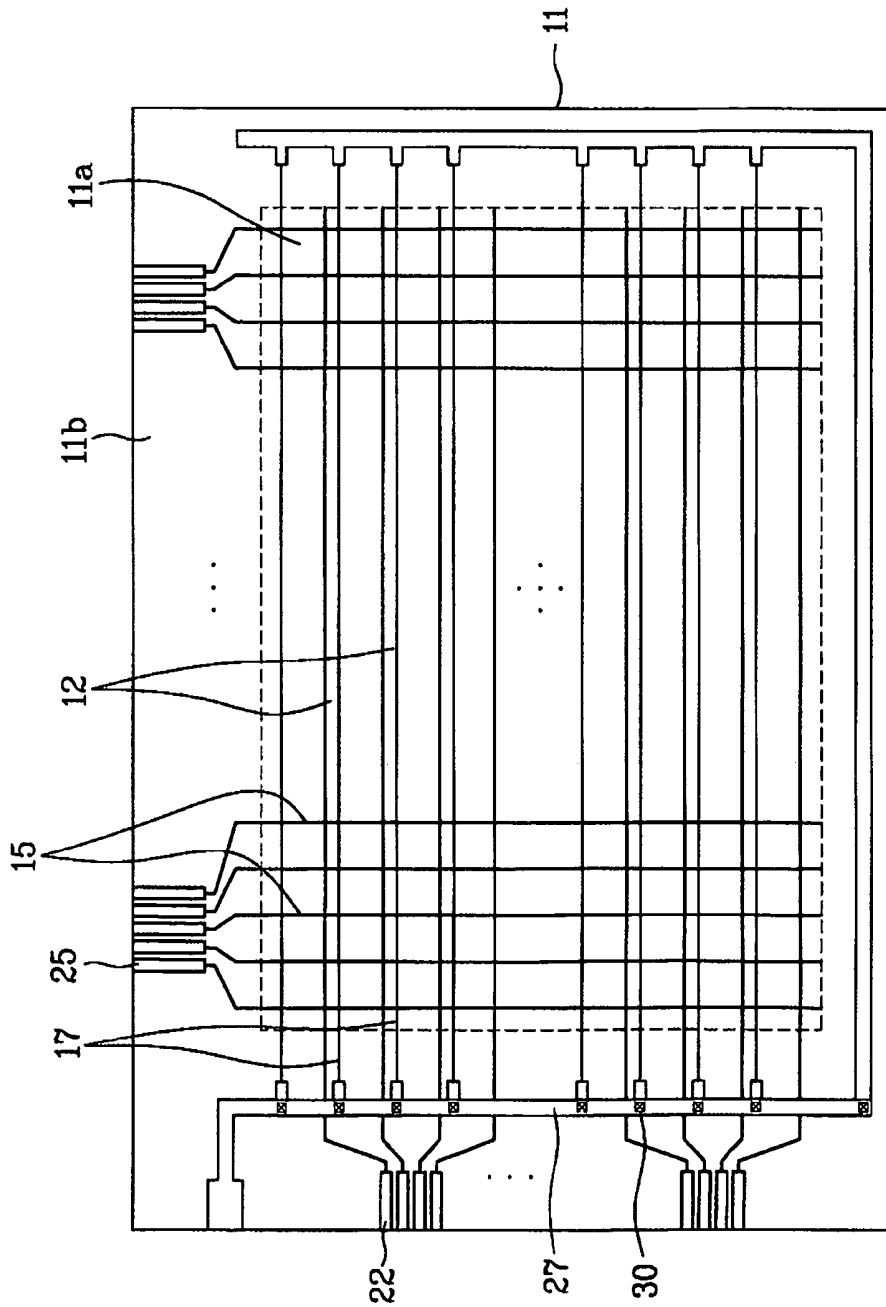

FIG. 2
Related Art

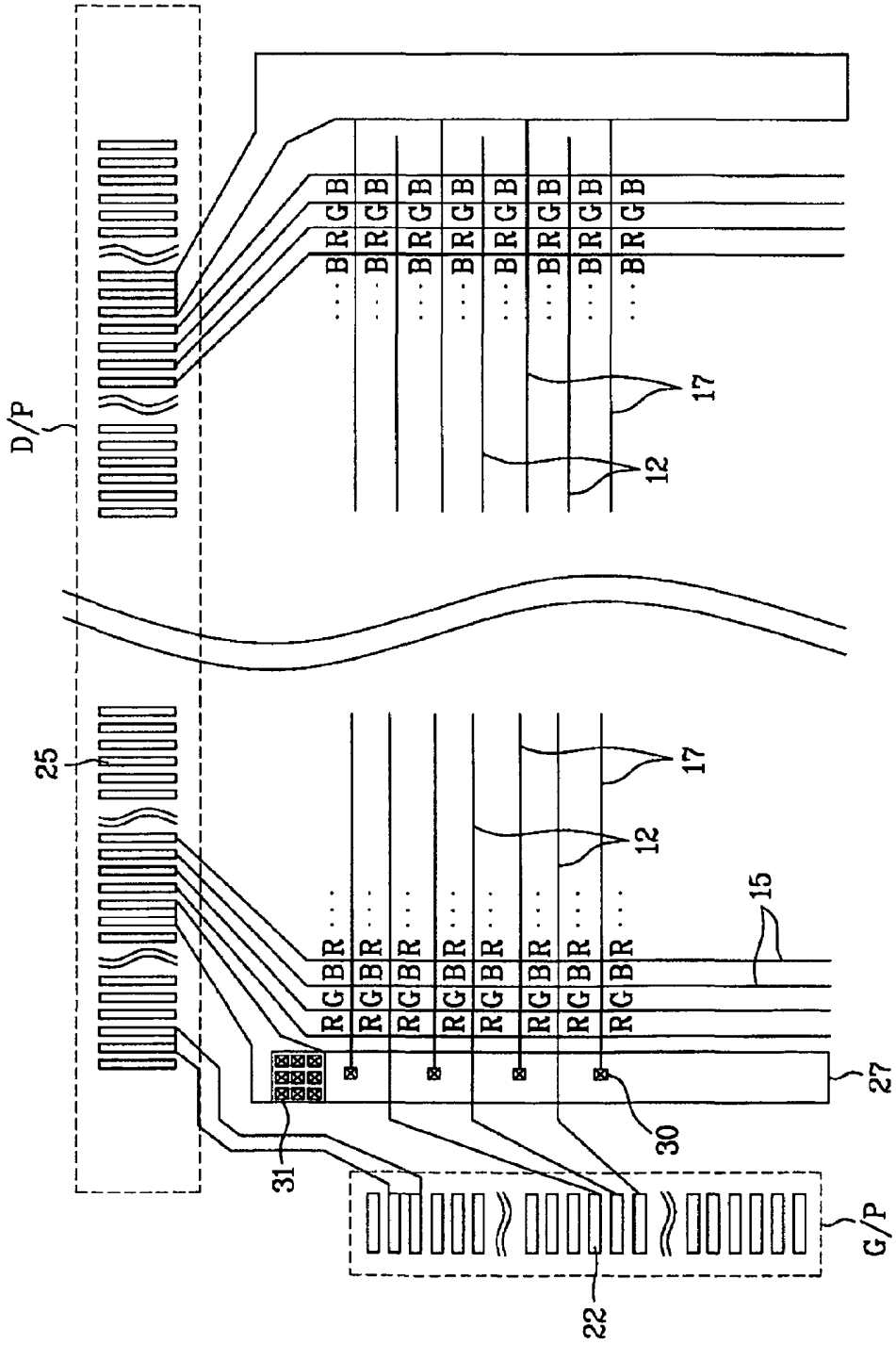

FIG. 3

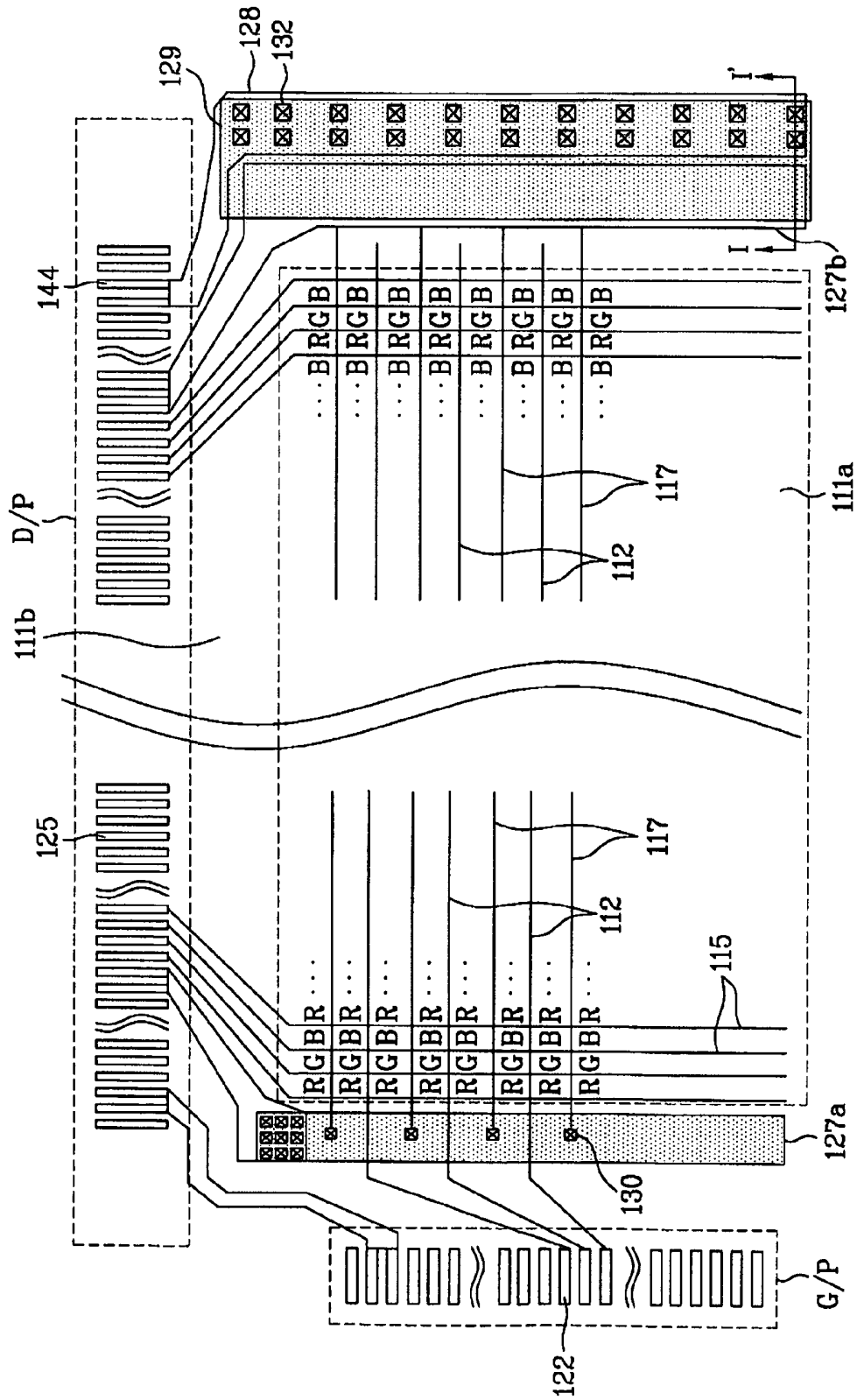

FIG. 4

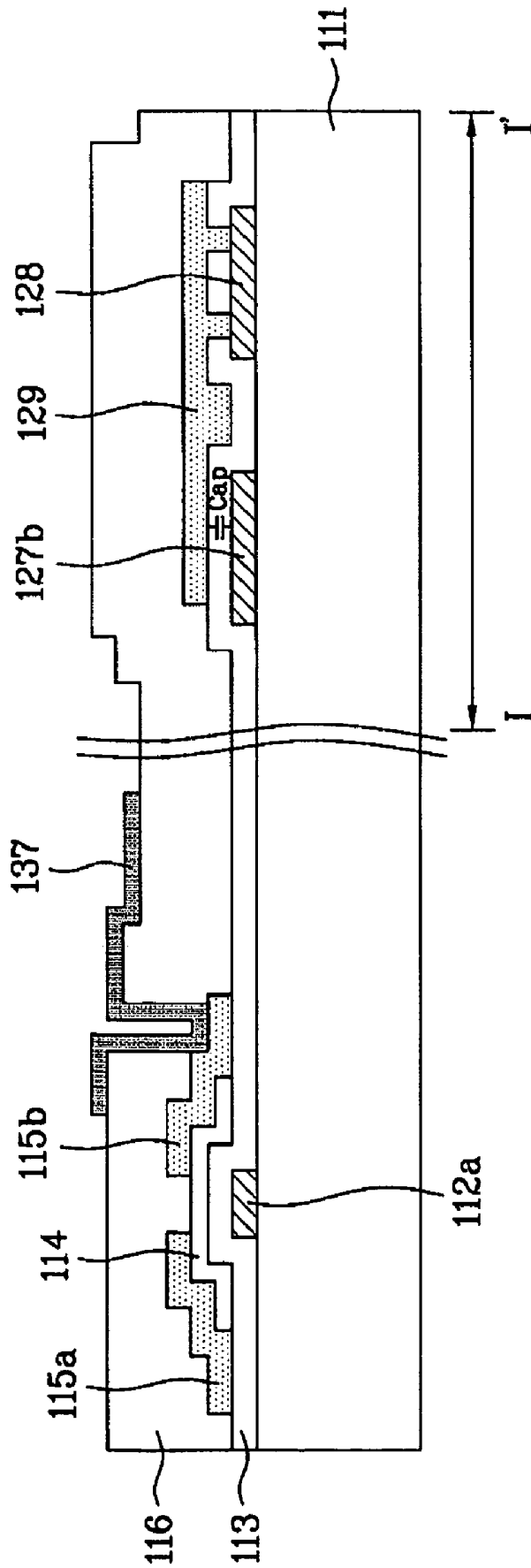

FIG. 5

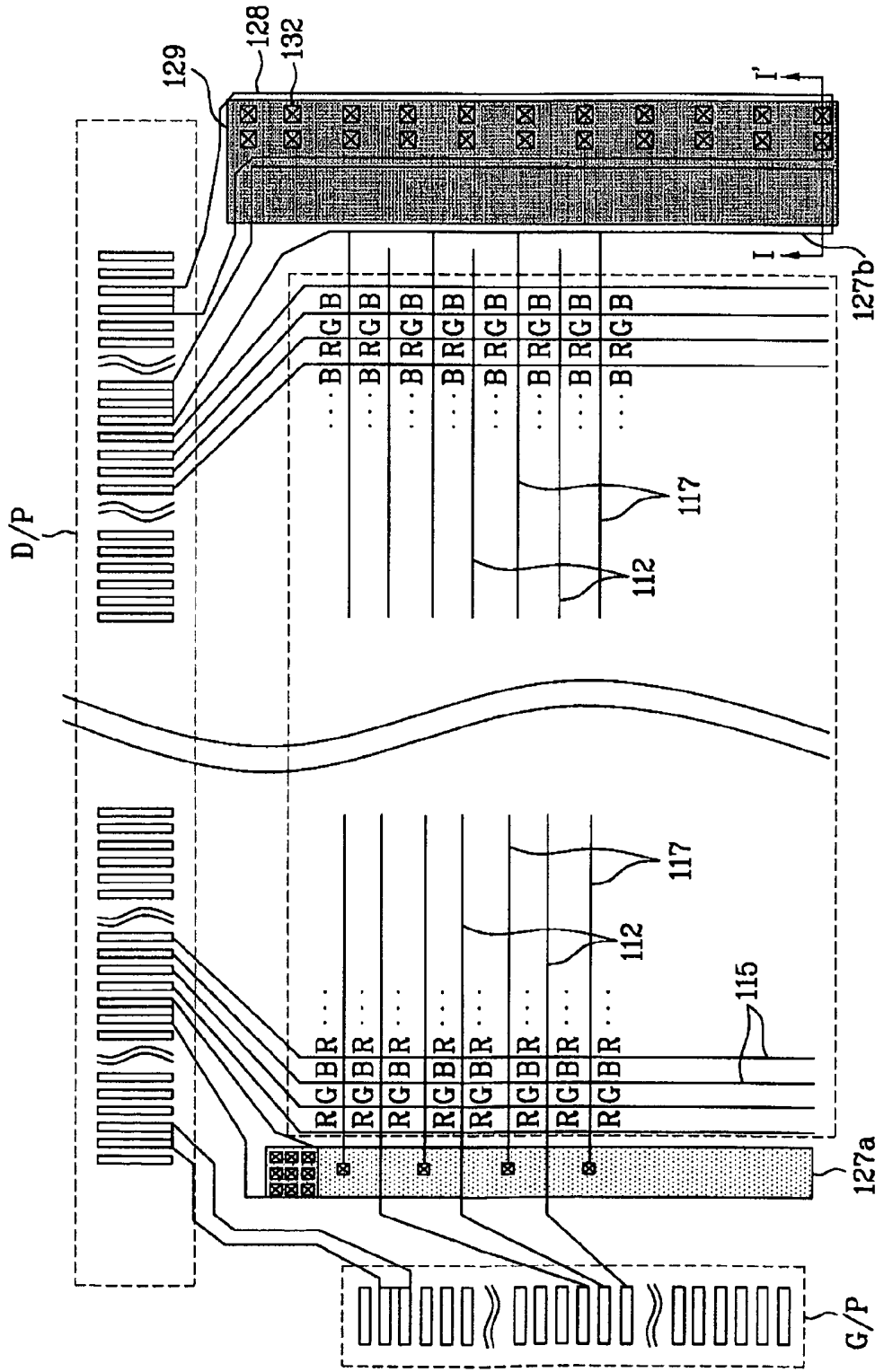

FIG. 7

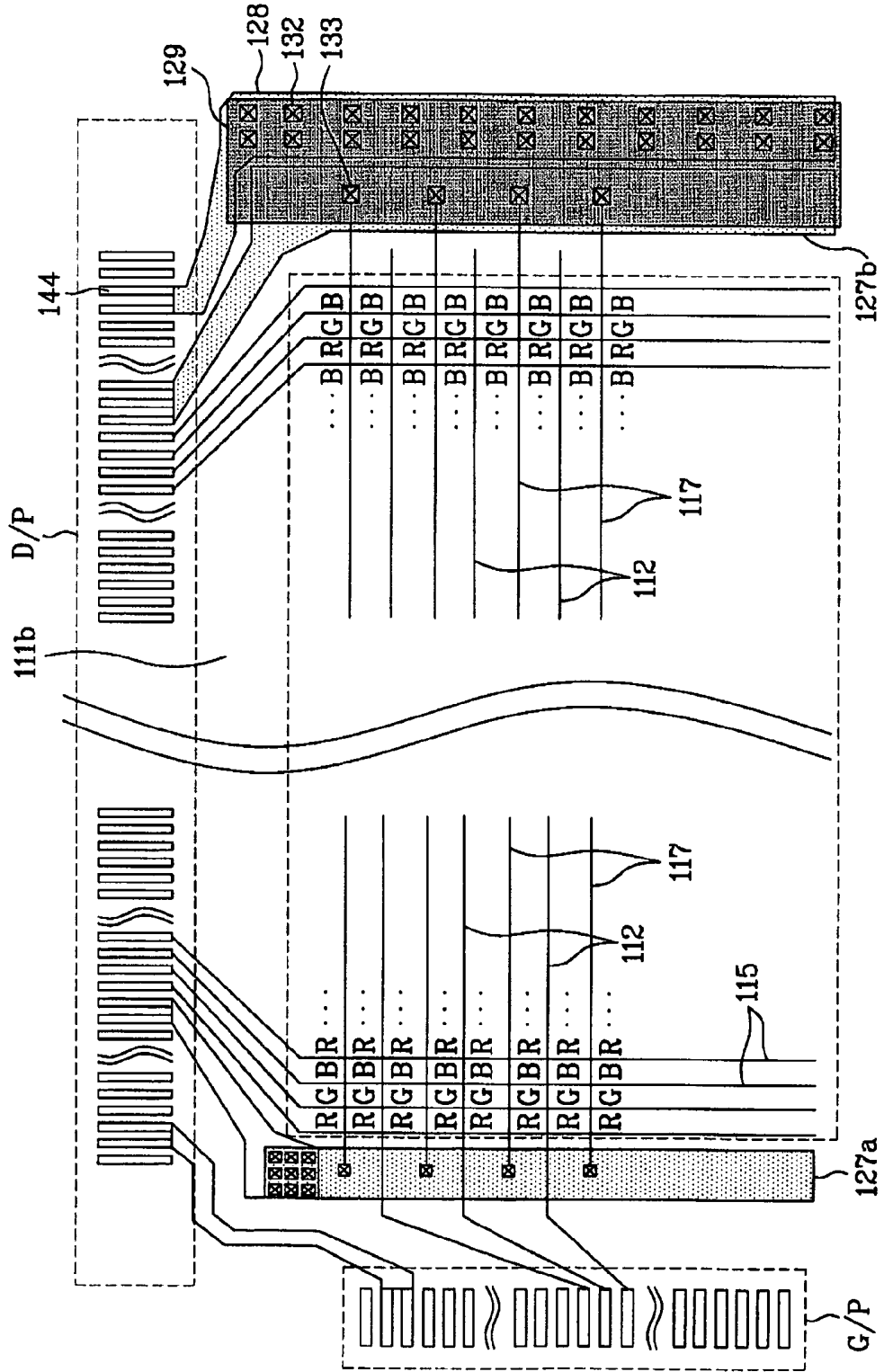

FIG. 8

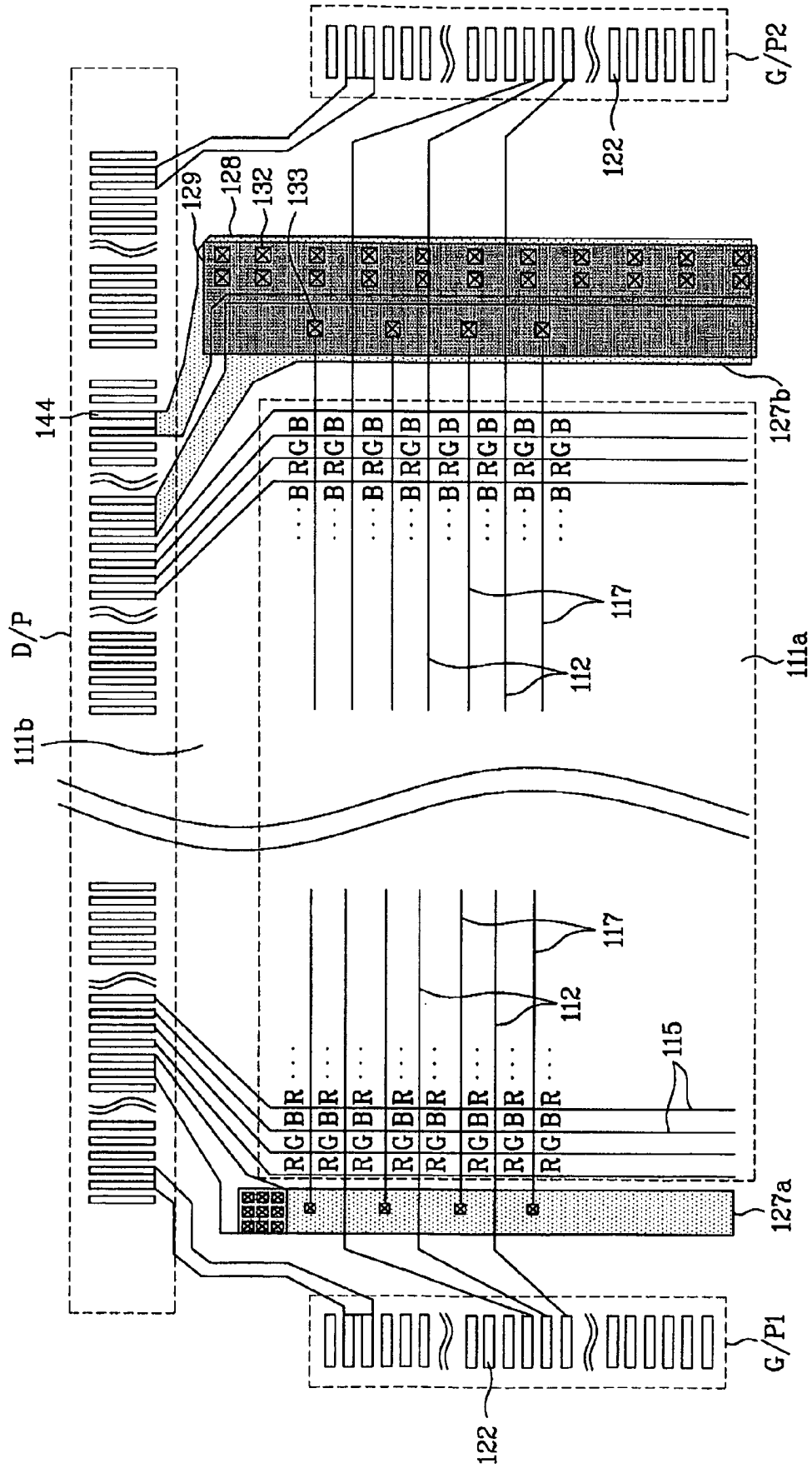

FIG. 10

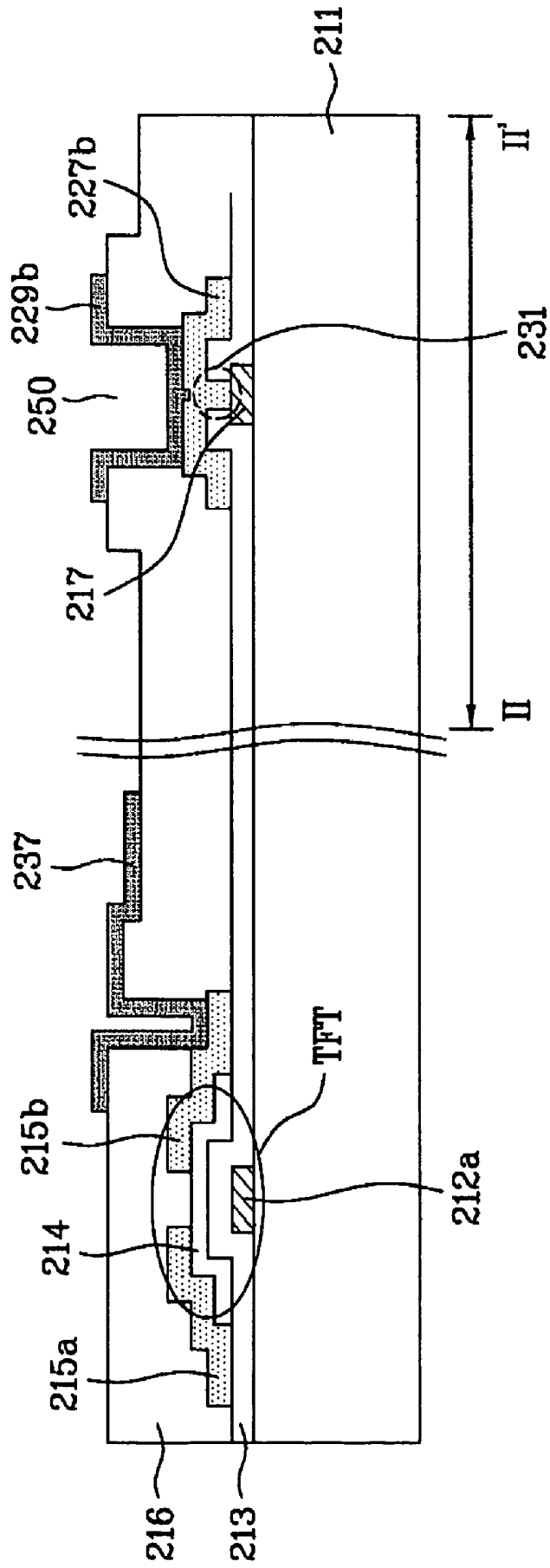
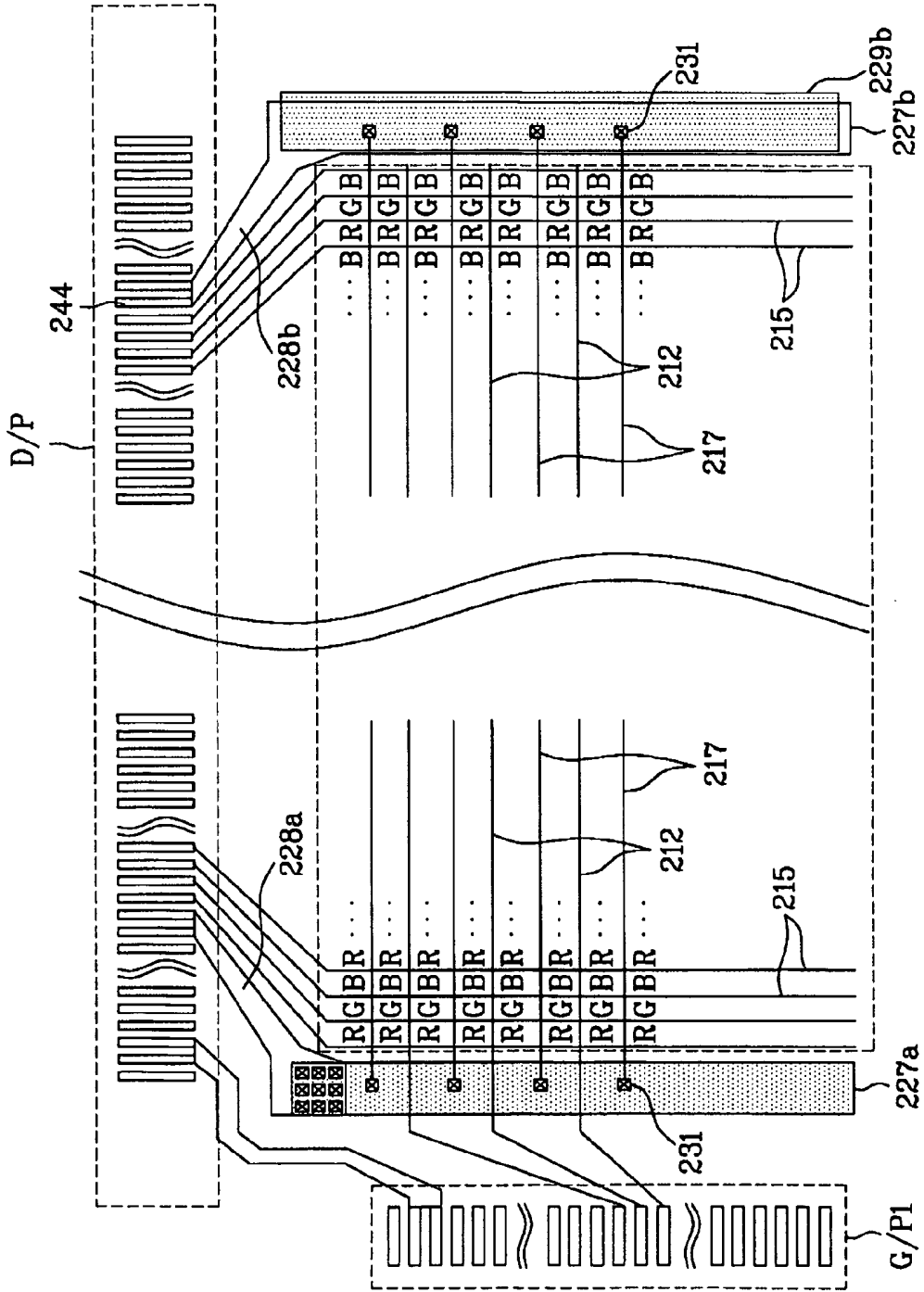

FIG. 11



LIQUID CRYSTAL DISPLAY DEVICE

This application claims the benefit of Korean Patent Application No. P2005-97130, filed on Oct. 14, 2005, which is hereby incorporated by reference in its entirety.

BACKGROUND OF THE INVENTION

1. Field of the Invention

The present invention relates to a display device, and more particularly, to a liquid crystal display (LCD) device. Although the present invention is suitable for a wide scope of applications, it is particularly suitable for stabilizing signals on a common voltage line in a pad region of the LCD device.

2. Discussion of the Related Art

In general, the liquid crystal display (LCD) device is a flat panel display device that has been actively researched due its advantages of high contrast ratio, desirable color display capacity and fast response time for displaying moving images. The LCD device has a lighter weight than a cathode ray tube (CRT) monitor and is also thinner than a cathode ray tube (CRT) monitor. Thus, an LCD device can be a display panel for use in a wall-mounted TV. In another example, an LCD device can be used as a display panel in a notebook computer powered by a battery due to its light weight, thin profile and low power consumption. Further, an LCD device can be manufactured to be a compact size, such as a miniature display panel for a mobile phone. The LCD device has a variety of applications due to its light weight, thin profile, low power consumption and scalability down to a compact size.

The LCD device includes an upper substrate, which is often referred to as a color filter layer array substrate, a lower substrate, which is often referred to as a TFT array substrate, and a layer of liquid crystal molecules disposed between the upper and lower substrates. Each of the upper and lower substrates can have an alignment film formed on an inner surface thereof. The alignment film has a pattern to orient the liquid crystal molecules in a predetermined direction. A related art liquid crystal display device will be described in detail with reference to FIG. 1 and FIG. 2.

FIG. 1 is a plan view of the related art liquid crystal display device, and FIG. 2 is a plan view illustrating a portion of a pad region of the related art liquid crystal display device shown in FIG. 1. An upper substrate (not shown) of the LCD device includes a black matrix (not shown) to prevent light leakage and a color filter layer (not shown) having red, green and blue color filters. As shown in FIG. 1, a lower substrate **11** is divided into an active region **11a** (area inside the dotted line shown in FIG. 1) and a pad region **11b** (area outside the dotted line shown in FIG. 1).

The active region **11a** is a region on which an image is displayed. The active region **11a** includes gate lines **12** crossing data lines **15** to define pixel regions. Common lines **17** also cross the data lines **15**. Thin film transistors (not shown) are formed in each pixel region adjacent to where one of the gate lines **12** for the pixel region and one of the data lines **15** for the pixel region cross. In addition, pixel electrodes (not shown) are formed in each of the pixel regions and connected to the thin film transistors in each of the pixel region.

The pad region **11b** includes gate pads **22** respectively connected to the gate lines **12**, data pads **25** respectively connected to the data lines **15**, and a common electrode **27** commonly connected to the common lines **17**. The gate pads **22**, the data pads **25** and the common electrode **27** receive signals from a printed circuit board (not shown) acting as a driving circuit.

As shown in FIG. 2, the lower substrate **11** has the gate lines **12** and the data lines **15** crossing each other to define pixels of red (R), green (G) and blue (B). Each of the pixels includes the thin film transistor acting as a switching element to apply a pixel voltage to the pixel electrode connected with the thin film transistor. The common lines **17** are parallel to the gate lines **12**. Each gate pad **22** is integrally formed with a corresponding gate line **12** in a gate pad region G/P, and each data pad **25** is integrally formed with a corresponding data line **15** in a data pad region D/P. The common electrode **27** is connected to all of the common lines **17** in the gate pad region G/P. To prevent a short circuit with the gate lines, the common electrode **27** is in a different layer from the gate lines inside the gate pad region G/P, and is electrically connected with the common lines **17** via contact holes **30**. The common lines **17** are in the same layer as the gate lines **12**.

A data signal is applied to the data lines **15** via the data pads **25** and a V_{com} signal for supplying a reference voltage for the data signal is applied to the common electrode **27**. However, such a related art liquid crystal display device has interference problems between the data signal and the V_{com} signal. The data signal V_{data} is supplied as an AC signal. The common signal V_{com} is supplied as a DC signal. Because the data lines having an AC signal overlap the common electrode, the AC signal in the data lines can cause a voltage ripple or distortion in the DC signal of the common lines. This voltage ripple or distortion of the V_{com} -signal causes a ripple of the voltage gap between the pixel voltage and V_{com} , and the ripple causes flickering of the images and/or greenish phenomena in the images.

SUMMARY OF THE INVENTION

Accordingly, the present invention is directed to a liquid crystal display device that substantially obviates one or more problems due to limitations and disadvantages of the related art.

An object of the present invention is to provide a liquid crystal display device that prevents distortion of the V_{com} signal.

Another object of the present invention to provide a liquid crystal display device that having a stable V_{com} signal.

Another object of the present invention to provide a liquid crystal display device that has a low resistance in receiving the V_{com} signal.

Additional advantages, objects, and features of the invention will be set forth in part in the description which follows and in part will become apparent to those having ordinary skill in the art upon examination of the following or may be learned from practice of the invention. The objectives and other advantages of the invention may be realized and attained by the structure particularly pointed out in the written description and claims hereof as well as the appended drawings.

To achieve these objects and other advantages and in accordance with the purpose of the invention, as embodied and broadly described herein, there is provided a liquid crystal display device with a liquid crystal layer disposed between first and second substrates in which the first substrate is divided into an active region and a pad region outside the active region that includes: gate lines and data lines crossing each other to define pixels in the active region of the first substrate; a thin film transistor and a pixel electrode in each of the pixels; common lines parallel to the gate lines in the active region; gate pads in the pad region, the gate pads electrically connected to the gate lines; data pads in the pad region, the data pads electrically connected to the data lines; a common

electrode along an edge of the active region and electrically connected with the common lines; an insulation film over the common electrode; and a distortion preventing electrode overlapping the common electrode with the insulation film interposed therebetween for creating a capacitance.

In accordance with another aspect of the present invention, there is provided a liquid crystal display device with a liquid crystal layer disposed between first and second substrates in which the first substrate is divided into an active region and a pad region outside the active region that includes: gate lines and data lines crossing each other to define pixels in the active region of the first substrate; a thin film transistor and a pixel electrode in each of the pixels; common lines parallel to the gate lines in the active region; gate pads in the pad region, the gate pads electrically connected to the gate lines; data pads in the pad region, the data pads electrically connected to the data lines; a common electrode along an edge of the active region and electrically connected with the common lines; and a distortion preventing electrode contacting along the common electrode.

In accordance with another aspect of the present invention, a method of fabricating a liquid crystal display device with a liquid crystal layer disposed between first and second substrates in which the first substrate is divided into an active region and a pad region outside the active region, includes: forming gate lines and data lines crossing each other to define pixels in the active region of the first substrate; forming a thin film transistor and a pixel electrode in each of the pixels; forming common lines parallel to the gate lines in the active region; forming gate pads in the pad region, the gate pads electrically connected to the gate lines; forming data pads in the pad region, the data pads electrically connected to the data lines; forming a common electrode along an edge of the active region and electrically connected with the common lines; forming an insulation film over the common electrode; and forming a distortion preventing electrode overlapping the common electrode with the insulation film interposed therebetween for creating a capacitance.

In accordance with another aspect of the present invention, a method of forming a liquid crystal display device with a liquid crystal layer disposed between first and second substrates in which the first substrate is divided into an active region and a pad region outside the active region, includes: forming gate lines and data lines crossing each other to define pixels in the active region of the first substrate; forming a thin film transistor and a pixel electrode in each of the pixels; forming common lines parallel to the gate lines in the active region; forming gate pads in the pad region, the gate pads electrically connected to the gate lines; forming data pads in the pad region, the data pads electrically connected to the data lines; forming a common electrode along an edge of the active region and electrically connected with the common lines; and forming a distortion preventing electrode contacting along the common electrode.

It is to be understood that both the foregoing general description and the following detailed description of the present invention are exemplary and explanatory and are intended to provide further explanation of the invention as claimed.

BRIEF DESCRIPTION OF THE DRAWINGS

The accompanying drawings, which are included to provide a further understanding of the invention and are incorporated in and constitute a part of this application, illustrate

embodiment(s) of the invention and together with the description serve to explain the principle of the invention. In the drawings:

FIG. 1 is a plan view illustrating the related art liquid crystal display device;

FIG. 2 is a plan view illustrating a pad region of the related art liquid crystal display device;

FIG. 3 is a plan view illustrating a pad region of a liquid crystal display device in accordance with a first embodiment of the present invention;

FIG. 4 is a cross-sectional view taken along line I-I' of FIG. 3;

FIG. 5 is a plan view illustrating a pad region of a liquid crystal display device in accordance with a second embodiment of the present invention;

FIG. 6 is a plan view illustrating a pad region of a liquid crystal display device in accordance with a third embodiment of the present invention;

FIG. 7 is a plan view illustrating a pad region of a liquid crystal display device in accordance with a fourth embodiment of the present invention;

FIG. 8 is a plan view illustrating a pad region of a liquid crystal display device in accordance with a fifth embodiment of the present invention;

FIG. 9 is a plan view illustrating a pad region of a liquid crystal display device in accordance with a sixth embodiment of the present invention;

FIG. 10 is a cross-sectional view taken along line II-II' of FIG. 9.

FIG. 11 is a plan view illustrating a pad region of a liquid crystal display device in accordance with a seventh embodiment of the present invention; and

FIG. 12 is a plan view illustrating a pad region of a liquid crystal display device in accordance with an eighth embodiment of the present invention;

DETAILED DESCRIPTION OF THE INVENTION

Reference will now be made in detail to the preferred embodiments of the present invention, examples of which are illustrated in the accompanying drawings. Wherever possible, the same reference numbers will be used throughout the drawings to refer to the same or like parts.

FIG. 3 is a plan view illustrating a pad region of a liquid crystal display device in accordance with a first embodiment of the present invention, and FIG. 4 is a cross-sectional view taken along line I-I' of FIG. 3. In addition, FIGS. 5, 6, 7 and 8 are respectively plan views illustrating a pad region of a liquid crystal display device in accordance with a second, third, fourth and fifth embodiments of the present invention.

Firstly, as shown in FIGS. 3 and 4, a TFT array substrate 111 of the first embodiment of the present invention is divided into an active region 111a in which thin film transistors switch pixel voltages to change an orientation of liquid crystal molecules and a pad region 111b for a connection to an external driving circuit. The active region 111a has gate lines 112 and data lines 115 crossing each other to define pixels of red (R), green (G) and blue (B). Each of the pixels includes a thin film transistor (TFT) acting as a switching element and a pixel electrode 137 penetrating a passivation layer 116 so as to connect with the thin film transistor such that a pixel voltage can be applied thereto. The common lines 117 are in the same layer as the gate lines 112 and are parallel to the gate lines 112.

The thin film transistor includes a gate electrode 112a integrally branching from the gate line 112 for the pixel, a gate insulation layer 113 above the gate electrode 112a, a

semiconductor layer **114** on the gate insulation layer **113**, and source/drain electrodes **115a/115b** overlapping the ends of the semiconductor layer and a portion of the gate insulation layer. The source/drain electrodes **115a/115b** are in the same layer as the data line **115** for the pixel. The gate insulation layer **113** is disposed between the gate lines and the data lines to insulate the gate line **112** and data line **115** from each other, and the passivation layer **116** is disposed on the semiconductor layer **114** and the gate insulation layer **113**, between the data line **115** and the pixel electrode **137** is connected to the drain electrodes **115b** through the contact hole.

If the liquid crystal display device is a TN mode LCD device, the common lines act as a storage electrode in each of their corresponding pixels. Also in the TN mode LCD device, an additional common electrode is on the color filter layer array substrate opposite to the pixel electrode for generating a vertical electric field to drive the liquid crystal molecules. If the LCD device is an IPS mode LCD device, the common lines are formed in parallel to the pixel electrode, generating a horizontal electric field for driving liquid crystals while also serving as a storage electrode in each of their corresponding pixels.

The pad region **111b** includes a plurality of gate pads **122** integrally connected to the gate lines **112**, a plurality of data pads **125** electrically connected to the data lines **115**, a first common electrode **127a** formed along a first edge of the pad region **111b** and electrically connected with the common lines **117**, a second common electrode **127b** formed along a second edge of the pad region **111b** opposite to the first edge and electrically connected with the common lines **117**, and a V_{com} distortion preventing electrode **129** overlapping the second common electrode **127b** with an insulation film, such as the gate insulation layer **113**, interposed therebetween to form capacitance between the V_{com} distortion preventing electrode **129** and the second common electrode **127b**. More specifically, the V_{com} distortion preventing electrode **129** is formed on an edge of the pad region **111b** opposite to the edge of the active along which the gate pads **122** are formed. The V_{com} distortion preventing electrode **129** is connected with a ground of a printed circuit board via a wiring pattern, such as a dummy line **128** to dummy pads **144**, so as to be grounded with the ground of the printed circuit board. The dummy line **128** is connected to dummy pads **144** in the data pad region D/P.

The gate pads **122** are formed in a gate pad region G/P, which is along the first edge of the pad region **111b** and the data pads **125** are formed in a data pad region D/P, which is along third edge of the pad region **111b** that is between the first edge of the pad region **111b** and the second edge of the pad region **111b** opposite to the first edge of the pad region **111b**. The first common electrode **127a** can be formed along the first edge of the pad region **111b**. The first common electrode **127a** is formed in a different layer from the gate lines **112** and is electrically connected with the common lines **117** via first contact holes **130**. The second common electrode **127b** along the second edge of the pad region **111b** is in the same layer as the gate lines. More specifically, the common electrodes **127a** and **127b** are formed in pad regions along edges of the active region, excluding the data pad region D/P. The common lines **117** are formed in the same layer as the gate lines **112**, and the second common electrode **127b** is integrally connected to all of the common lines **117**.

The V_{com} distortion preventing electrode **129** overlaps an upper surface of the second common electrode **127b**. The V_{com} distortion preventing electrode **129** is in the same layer as the data lines **115**. The V_{com} distortion preventing electrode **129** is electrically connected with the dummy line **128** via the

second contact holes **132** so as to electrically connect to the dummy pads **144**, which are grounded.

If the dummy line **128** and the dummy pads **144** are in the same layer as the gate lines as described above, the dummy line **128** is contacted with the V_{com} distortion preventing electrode via the second contact holes **132**. Alternatively, if the dummy line **128** is in the same layer as the data lines, the dummy line **128** can be integrally formed with the V_{com} distortion preventing electrode. As such, if the V_{com} distortion preventing electrode **129** is in the same layer as the data lines, and the second common electrode **127b** in the same layer as the gate lines is overlapped by the V_{com} distortion preventing electrode **129**, the gate insulation layer **113** is sandwiched between the second common electrode **127b** and the V_{com} distortion preventing electrode **129**, thereby generating capacitance ('Cap' in FIG. 4) to prevent distortion of a V_{com} signal.

When the V_{com} distortion preventing electrode **129** is grounded, and the V_{com} signal flows to the second common electrode **127b** overlapped therewith, and if the V_{com} signal receives an AC distortion from the data lines, the distortion flows to the V_{com} distortion preventing electrode **129**. As a result, the distortion flows to the ground and leaves only the V_{com} signal, thereby preventing the distortion of the V_{com} signal.

Meanwhile, as shown in FIG. 5, the second common electrode **127b** may be formed in the same layer as the gate lines **112** and integrally connected with the common line **117**. And, the V_{com} distortion preventing electrode **129** may be formed in the same layer as the pixel electrode (**137** of FIG. 4), electrically connected with the dummy line **128** via the second contact hole **132**, and overlap the second common electrode **127b**. Therefore, the gate insulation layer (**113** of FIG. 4) and passivation layer (**116** of FIG. 4) are sandwiched between the second common electrode **127b** and the V_{com} distortion preventing electrode **129**, thereby generating capacitance to prevent distortion of a V_{com} signal.

Additionally, as shown in FIG. 6, the second common electrode **127b** may be formed in the same layer as the data lines **115** and electrically connected with the common line **117** via a third contact hole **133**. And, the V_{com} distortion preventing electrode **129** may be formed in the same layer as the gate lines **112**, electrically connected with the dummy line **128** via the second contact hole **132**, and overlap the second common electrode **127b**. Therefore, the gate insulation layer (**113** of FIG. 4) is sandwiched between the second common electrode **127b** and the V_{com} distortion preventing electrode **129**, thereby generating capacitance to prevent distortion of a V_{com} signal. At this time, the gate or common lines **112** or **117** and the V_{com} distortion preventing electrode **129** are formed separately not to be shorted with each other.

And, as shown in FIG. 7, the second common electrode **127b** may be formed in the same layer as the data lines **115** and electrically connected with the common line **117** via a third contact hole **133**. And, the V_{com} distortion preventing electrode **129** may be formed in the same layer as the pixel electrode (**137** of FIG. 4), electrically connected with the dummy line **128** via the second contact hole **132**, and overlap the second common electrode **127b**. Therefore, the passivation layer (**116** of FIG. 4) is sandwiched between the second common electrode **127b** and the V_{com} distortion preventing electrode **129**, thereby generating capacitance to prevent distortion of a V_{com} signal.

In FIGS. 3, 5, 6 and 7, TFT array substrate may be further comprise an additional V_{com} distortion preventing electrode (not shown), wherein the additional V_{com} distortion preventing electrode may be formed in the same layer as the pixel

electrode and overlap the first common electrode **127a** with the passivation layer interposed therebetween to form an additional capacitance between the additional V_{com} distortion preventing electrode and the first common electrode. At this time, the first common electrode is formed in the same layer as the data lines and on the first edges of the pad region as described above. And, the additional V_{com} distortion preventing electrode is applied with a ground voltage via an additional dummy pattern connected with the additional V_{com} distortion preventing electrode.

In case that the gate pads are first edge of the pad region and the data pads are third edge of the pad region as above, the second common electrode can be formed on the edges of the pad region including the second edge opposite to the first edge and a fourth edge opposite to the third edge excluding the first edge of the pad region in contrast with the first, second, third and fourth embodiment. At this time, the V_{com} distortion preventing electrode can be in the same layer as the gate lines or the pixel electrode, thereby forming capacitance between the second common electrode and the v_{com} distortion preventing electrode. Alternatively, when the v_{com} distortion preventing electrode is in the same layer as the data lines, the second common electrode can be in the same layer as the gate lines or the pixel electrode.

The above description describes first to fourth embodiment in which the gate pad region G/P is formed only along the first edge of the active region. However, embodiments of the present invention are not limited to this embodiment. For example, when gate pad regions G/P1 and G/P2 are respectively on the first and second edges of the pad region, there is another embodiment of the present invention for preventing ripple in the V_{com} signal.

As shown in FIG. 8, the pad region **111b** of the fifth embodiment can include two gate pad regions G/P1 and G/P2, wherein the respective pad region comprise a plurality of gate pads **122**. The gate pads **122** are connected integrally with gate lines **112**, thereby the respective gate line is applied with a same signal from two gate pad regions G/P1 and G/P2. In this case, both the first and the second common electrodes **127a** and **127b** are in the same layer as the data lines **115**, and the v_{com} distortion preventing electrodes **129** overlapping the second common electrodes **127a** is in the same layer as the pixel electrode, thereby forming capacitance between the second common electrodes **127b** and the v_{com} distortion preventing electrodes **129**. The v_{com} distortion preventing electrodes **129** is applied with the ground voltage via dummy line **128** and dummy pattern **144**. Additionally, an additional V_{com} distortion preventing electrodes (not shown) can be further formed over the first common electrode **127a** to form an additional capacitance, wherein the additional V_{com} distortion preventing electrodes is applied with a ground voltage and formed in the same layer as the pixel electrode.

Although the above description has been described only to the embodiments which constitute the capacitance for causing the distortion of a v_{com} signal to flow to the ground, it is possible to stabilize the V_{com} signal by lowering the resistance in the common electrodes through which a v_{com} signal flows. Thus, a v_{com} distortion preventing electrode can be directly formed on the common electrodes exposed externally through openings, which are formed by removing a portion of an insulation layer over the common electrode.

FIG. 9 is a plan view illustrating a pad region of a liquid crystal display device in accordance with a sixth embodiment of the present invention, and FIG. 10 is a cross-sectional view taken along line II-II' of FIG. 9. FIG. 11 is a plan view illustrating a pad region of a liquid crystal display device in accordance with a seventh embodiment of the present inven-

tion, and FIG. 12 is a plan view illustrating a pad region of a liquid crystal display device in accordance with a eighth embodiment of the present invention.

As shown in FIGS. 9 and 10, an active region **211a** has a plurality of gate lines **212** and a plurality of data lines **215** crossing each other to define pixels of red (R), green (G) and blue (B). Each of the pixels includes a thin film transistor (TFT) acting as a switching element, a pixel electrode **237** penetrating a passivation layer **216** and contacting a drain electrode **215b** of the thin film transistor, and common lines **217** in the same layer as the gate lines. The common lines **217** are parallel to the gate lines **212**. A gate insulation layer **213** is between a gate lines layer and a data lines layer. Since the common lines **217** are in the same layer as the gate lines, the gate insulation layer **213** is also on the common lines **217**.

The pad region **211b** is provided with a gate pad region G/P having a plurality of gate pads **222** extending from the gate lines **212**, a data pad region D/P having a plurality of data pads **225** extending from the data lines **215**, a common electrode **227** connected to the common lines and along at least one of the edges of the active region **211a**, excluding the edge having the data pad region D/P, and a v_{com} distortion preventing electrode **229** contacting along the common electrode to reduce resistance when a v_{com} signal flows therethrough. For example, the gate pads, common electrodes and v_{com} distortion preventing electrodes are formed on opposite edges of the pad region, and the data pads are formed along another edge of the active region **111a** where the gate pads are not formed. As shown in FIG. 9, the pad region **211b** can include a first common electrode **227a** and a second common electrode **227b** connected to the common lines **217** in two gate pad regions G/P1 and G/P2. A first V_{com} distortion preventing electrode **229a** and a second v_{com} distortion preventing electrodes **229b** are respectively contacting along the first common electrode **227a** and the second common electrode **227b**.

The common electrodes **227a** and **227b** provided between the gate pad regions G/P1 and G/P2 and the active region are in the same layer as the data lines. The gate insulation layer **213** is between the common lines **217** and the common electrode **227**, but the common lines **217** and the common electrodes **227a** and **227b** are electrically connected via first contact holes **231** formed by removing a portion of the gate insulation layer.

The pad region **211b** also includes additional common electrodes **228a** and **228b** for a connection to an exterior driving circuit to apply a V_{com} signal to the common electrodes **227a** and **227b**. Since the additional common electrodes **228a** and **228b** are in the same layer as the gate lines **212**, the additional common electrodes **228a** and **228b** and the common electrodes **227a** and **227b** are electrically connected via second contact holes **233** formed by removing portions of the gate insulation layer **213**.

The passivation layer **216** is formed over the data lines **215** and the common electrodes **227a** and **227b** such that the V_{com} distortion preventing electrodes **229a** and **229b** are directly formed on the common electrodes **227a** and **227b** through openings (**250** of FIG. 10) in the passivation layer **216** formed by removing a portion of the passivation layer over the common electrodes **227a** and **227b**. The openings **250** are simultaneously formed during a process of forming contact holes through which the pixel electrode **237** contacts the drain electrode. The v_{com} distortion preventing electrodes **229a** and **229b** are in the same layer as the pixel electrode **237**. When the V_{com} distortion preventing electrode is formed along the common electrode, the v_{com} signal flows not only through the

common electrode, but also through the v_{com} distortion preventing electrode. Thus, resistance against the v_{com} signal is reduced.

The above description is with regard to an embodiment in which the gate pad regions are only on the opposite edges of the substrate. However, it should be noted that the present invention is not limited to this embodiment, and that the present invention can be applied to the embodiment in which a single gate pad region G/P is formed only on one edge of the pad region as shown in FIGS. 11 and 12. Specifically, the present invention can be applied to a case in which the gate pads are defined on first edge of the pad region, and the data pads formed on third edge of the pad region where the gate pads are not formed, and the v_{com} distortion preventing electrode is formed along the second common electrode on second edge of the pad region opposite to the first edge where the gate pads are located. Additionally, in the FIG. 9, it is also possible only to remove the pad region G/P2 in state of remaining other patterns. At this time, the V_{com} distortion preventing electrode in the first edge of the pad region can be removed as shown in FIGS. 11 and 12 or remained as shown in FIG. 9.

In more detail, as shown in FIG. 11, the V_{com} distortion preventing electrode 229b can be formed in the same layer as the data lines 215, and the second common electrode 227b can be formed in the same layer as the gate lines 112 and connected integrally with the common lines 217 and the additional common electrode 228b. In this case, the second common electrode 227b is exposed to the outside via an opening formed by removing a portion of the gate insulation layer above the second common electrode. Then, the v_{com} distortion preventing electrode 229b is contacted directly along the second common electrode 227b through the opening in the gate insulation layer.

Although not shown in FIG. 11, when the V_{com} distortion preventing electrode 229b is formed in the same layer as the data lines 215, the second common electrode may be formed in the same layer as the pixel electrode without forming in the same layer as the gate lines. In this case, the v_{com} distortion preventing electrode is exposed to the outside via an opening formed by removing a portion of the passivation layer above the second common electrode. Then, the v_{com} distortion preventing electrode is contacted along the second common electrode through the opening in the passivation layer. At this time, the second common electrode is applied with a common signal via the V_{com} distortion preventing electrode (229b of FIG. 11) connected with the additional common electrode (228b of FIG. 11) and

Meanwhile, as shown in FIG. 12, the v_{com} distortion preventing electrode 229b can be formed in the same layer as the gate lines and connected integrally with the additional common electrode 228b and common lines 217, and the second common electrode 227b can be formed in the same layer as the pixel electrode and connected electrically with the additional common electrode 228b and common lines 217 via the v_{com} distortion preventing electrode 229b. In this case, the V_{com} distortion preventing electrode 229b is exposed to the outside via the opening formed by removing portions of the gate insulation layer and the passivation layer above the second common electrode 227b. Then, the V_{com} distortion preventing electrode 229b is contacted along the second common electrode 227b through the opening in the gate insulation layer and in the passivation layer.

Although not shown in FIG. 12, when the V_{com} distortion preventing electrode 229b is formed in the same layer as the gate lines 212, the second common electrode can be formed in the same layer as the data lines without forming in the same

layer as the pixel electrode. In this case, the v_{com} distortion preventing electrode is exposed to the outside via the opening formed by removing a portion of the gate insulation layer above the second common electrode. Then, the v_{com} distortion preventing electrode is contacted along the second common electrode through the opening in the gate insulation layer. At this time, the second common electrode is applied with a common signal via the v_{com} distortion preventing electrode 229b connected with the additional common electrode (228b of FIG. 12).

In the FIGS. 11 and 12, the first common electrode 227a in the first edge of the pad region is in the same layer as the data lines 115 and is connected with the common lines 217 via first contact holes 231. As mentioned above, an additional v_{com} distortion preventing electrode (not show) can be further comprised in the FIGS. 11 and 12 such as the FIG. 9, wherein the additional V_{com} distortion preventing electrode may be contacted directly along the first common electrode 227a through the opening in the gate insulation layer.

As apparent from the above description, the LCD device according to embodiments of the present invention has several advantages. An LCD device having a v_{com} distortion preventing electrode formed above the common electrode of the pad region with the insulation film interposed between the V_{com} distortion preventing electrode and the common electrode can realize capacitance to remove voltage ripple in the v_{com} signal. In the alternative, the liquid crystal display device can have an opening formed by removing a portion of the insulation film over the common electrode in the pad region such that the v_{com} distortion preventing electrode can be directly contacted along the common electrode in the opening to reduce resistance against the v_{com} signal and stabilize the v_{com} signal. Thus, flickering, a greenish phenomenon, and the like caused by the ripple of the V_{com} signal can be prevented, thereby enhancing image quality.

It will be apparent to those skilled in the art that various modifications and variations can be made in the present invention without departing from the spirit or scope of the inventions. Thus, it is intended that the present invention covers the modifications and variations of this invention provided they come within the scope of the appended claims and their equivalents.

What is claimed is:

1. A liquid crystal display device with a liquid crystal layer disposed between first and second substrates in which the first substrate is divided into an active region and a pad region outside the active region, comprising:

gate lines and data lines crossing each other to define pixels in the active region of the first substrate;

a thin film transistor and a pixel electrode in each of the pixels;

common lines parallel to the gate lines in the active region; gate pads in the pad region, the gate pads electrically connected to the gate lines;

data pads in the pad region, the data pads electrically connected to the data lines;

at least one common electrode along edges of the pad region and electrically connected with the common lines;

an insulation film over the common electrode; and

at least one distortion preventing electrode overlapping the common electrode with the insulation film interposed therebetween for creating a capacitance.

2. The liquid crystal display device according to claim 1, wherein the distortion preventing electrode is grounded.

11

3. The liquid crystal display device according to claim 2, further comprising a dummy pads in the pad region in which the data pads are located, and a dummy line in parallel to the common electrode,

wherein the distortion preventing electrode is connected with a ground of a printed circuit board via a dummy line to dummy pads.

4. The liquid crystal display device according to claim 1, wherein the gate pads are formed only on one edge of the pad region, and the data pads are formed on another edge of the pad region.

5. The liquid crystal display device according to claim 4, wherein the common electrode comprises a first common electrode is located between the gate pads and the active region and a second common electrode in opposition to the first common electrode.

6. The liquid crystal display device according to claim 5, wherein the common lines are in the same layer as the gate lines, and the first common is in the same layer as the data lines and is connected with the common lines via contact holes.

7. The liquid crystal display device according to claim 6, wherein the distortion preventing electrode is overlapped over the first common electrode and formed in the same layer as the pixel electrode.

8. The liquid crystal display device according to claim 5, wherein the common lines are in the same layer as the gate lines, and the second common electrode is formed integrally with the common lines or connected with the common lines via contact holes.

9. The liquid crystal display device according to claim 8, wherein the distortion preventing electrode is in the same layer as the data lines and the second common electrode is in the same layer as the gate lines.

10. The liquid crystal display device according to claim 8, wherein the distortion preventing electrode is in the same layer as the data lines and the second common electrode is in the same layer as the pixel electrode.

11. The liquid crystal display device according to claim 8, wherein the distortion preventing electrode is in the same layer as the gate lines and the second common electrode is in the same layer as the data lines.

12. The liquid crystal display device according to claim 8, wherein the distortion preventing electrode is in the same layer as the gate lines and the second common electrode is in the same layer as the pixel electrode.

13. The liquid crystal display device according to claim 1, wherein the gate pads are along opposite edges of the pad region and the data pads are along another edge of the pad region.

14. The liquid crystal display device according to claim 13, wherein the common electrode is located between the gate pads and active region.

15. The liquid crystal display device according to claim 14, wherein the common lines are in the same layer as the gate lines, the common electrode is in the same layer as the data lines, and the distortion preventing electrode is in the same layer as the pixel electrode.

16. The liquid crystal display device according to claim 15, wherein the distortion preventing electrode is overlapped over the common electrode along opposite edges or one edge of the pad region which the gate pads are located.

17. A liquid crystal display device with a liquid crystal layer disposed between first and second substrates in which the first substrate is divided into an active region and a pad region outside the active region, comprising:

12

gate lines and data lines crossing each other to define pixels in the active region of the first substrate;

a thin film transistor and a pixel electrode in each of the pixels;

common lines parallel to the gate lines in the active region; gate pads in the pad region, the gate pads electrically connected to the gate lines;

data pads in the pad region, the data pads electrically connected to the data lines;

at least one common electrode along edges of the pad region and electrically connected with the common lines; and

at least one distortion preventing electrode contacting along the common electrode.

18. The liquid crystal display device according to claim 17, wherein the gate pads are formed only on one edge of the pad region, and the data pads are formed on another edge of the pad region.

19. The liquid crystal display device according to claim 18, wherein the common electrode comprises a first common electrode between the gate pads and the active region and a second common electrode in opposition to the first common electrode.

20. The liquid crystal display device according to claim 19, wherein the common lines are in the same layer as the gate lines, the first common electrode is in the same layer as the data lines and is connected with the common lines via contact holes, and the distortion preventing electrode is formed in the same layer as the pixel electrode.

21. The liquid crystal display device according to claim 20, further comprising a passivation layer between the first common electrode and the distortion preventing electrode, the passivation layer having an opening in which the distortion preventing electrode contacts the first common electrode.

22. The liquid crystal display device according to claim 19, wherein the common lines are in the same layer as the gate lines, and the second common electrode is formed integrally with the common lines or connected with the common lines via contact holes.

23. The liquid crystal display device according to claim 22, wherein the distortion preventing electrode is in the same layer as the data lines and the second common electrode is in the same layer as the gate lines.

24. The liquid crystal display device according to claim 23, further comprising:

a gate insulation layer between the second common electrode and the distortion preventing electrode, the gate insulation layer having an opening in which the distortion preventing electrode contacts the second common electrode.

25. The liquid crystal display device according to claim 22, wherein the distortion preventing electrode is in the same layer as the data lines and the second common electrode is in the same layer as the pixel electrode.

26. The liquid crystal display device according to claim 25, further comprising:

a passivation layer between the second common electrode and the distortion preventing electrode, the passivation layer having an opening in which the distortion preventing electrode contacts the second common electrode.

27. The liquid crystal display device according to claim 22, wherein the distortion preventing electrode is in the same layer as the gate lines and the second common electrode is in the same layer as the data lines.

28. The liquid crystal display device according to claim 27, further comprising:

13

a gate insulation layer between the second common electrode and the distortion preventing electrode, the gate insulation layer having an opening in which the distortion preventing electrode contacts the second common electrode.

29. The liquid crystal display device according to claim 22, wherein the distortion preventing electrode is formed in the same layer as the gate lines and the second common electrode is in the same layer as the pixel electrode.

30. The liquid crystal display device according to claim 29, further comprising:

a gate insulation layer and a passivation layer between the second common electrode and the distortion preventing electrode, both the gate insulation layer and the passivation layer having an opening in which the distortion preventing electrode contacts the second common electrode.

31. The liquid crystal display device according to claim 17, wherein the gate pads are along opposite edges of the pad region, and the data pads are along another edge of the active region.

32. The liquid crystal display device according to claim 31, wherein the common electrode is located between the gate pads and active region.

33. The liquid crystal display device according to claim 32, wherein the common electrode is in the same layer as the data lines and the distortion preventing electrode is in the same layer as the pixel electrode.

34. The liquid crystal display device according to claim 33, further comprising:

a passivation layer between the common electrode and the distortion preventing electrode, the passivation layer having an opening in which the distortion preventing electrode contacts the common electrode.

35. The liquid crystal display device according to claim 34, wherein the distortion preventing electrode contacts the common electrode via the opening along opposite edges or one edge of the pad region which the gate pads are located.

36. A method of fabricating a liquid crystal display device with a liquid crystal layer disposed between first and second substrates in which the first substrate is divided into an active region and a pad region outside the active region, comprising:

forming gate lines and data lines crossing each other to define pixels in the active region of the first substrate;
forming a thin film transistor and a pixel electrode in each of the pixels;

14

forming common lines parallel to the gate lines in the active region;

forming gate pads in the pad region, the gate pads electrically connected to the gate lines;

forming data pads in the pad region, the data pads electrically connected to the data lines;

forming at least one common electrode along edges of the active region and electrically connected with the common lines;

forming an insulation film over the common electrode; and forming at least one distortion preventing electrode overlapping the common electrode with the insulation film interposed therebetween for creating a capacitance.

37. The method of fabricating a liquid crystal device according to the claim 36, further comprising the step of forming dummy pads in the pad region, wherein the dummy pads electrically connect with the ground and connected to the distortion preventing electrode therebetween.

38. A method of forming a liquid crystal display device with a liquid crystal layer disposed between first and second substrates in which the first substrate is divided into an active region and a pad region outside the active region, comprising:

forming gate lines and data lines crossing each other to define pixels in the active region of the first substrate;

forming a thin film transistor and a pixel electrode in each of the pixels;

forming common lines parallel to the gate lines in the active region;

forming gate pads in the pad region, the gate pads electrically connected to the gate lines;

forming data pads in the pad region, the data pads electrically connected to the data lines;

forming at least one common electrode along edges of the active region and electrically connected with the common lines; and

forming at least one distortion preventing electrode contacting along the common electrode.

39. The liquid crystal display device according to claim 38, further comprising:

a insulation film between the common electrode and the distortion preventing electrode, the insulation film having an opening in which the distortion preventing electrode contacts the common electrode.

* * * * *

专利名称(译)	液晶显示装置		
公开(公告)号	US7460203	公开(公告)日	2008-12-02
申请号	US11/475910	申请日	2006-06-28
[标]申请(专利权)人(译)	乐金显示有限公司		
申请(专利权)人(译)	LG.PHILIPS LCD CO. , LTD.		
当前申请(专利权)人(译)	LG DISPLAY CO. , LTD.		
[标]发明人	KIM SEOK SU		
发明人	KIM, SEOK SU		
IPC分类号	G02F1/1345		
CPC分类号	G02F1/1345 G02F2001/133388 G02F2201/121		
优先权	1020050097130 2005-10-14 KR		
其他公开文献	US20070085960A1		
外部链接	Espacenet USPTO		

摘要(译)

一种液晶显示装置，其中液晶层设置在第一和第二基板之间，其中第一基板被分成有源区和有源区外部的焊盘区，其包括：栅极线和数据线彼此交叉以限定像素第一基板的有源区；每个像素中的薄膜晶体管和像素电极；与有源区中的栅极线平行的公共线；焊盘区域中的栅极焊盘，栅极焊盘电连接到栅极线；焊盘区域中的数据焊盘，数据焊盘电连接到数据线；沿有源区边缘的公共电极，与公共线电连接；公共电极上方的绝缘膜；防止电极与公共电极重叠，绝缘膜插入其间以形成电容。

