



US 20090185092A1

(19) **United States**
(12) **Patent Application Publication**
Park et al.

(10) **Pub. No.: US 2009/0185092 A1**
(43) **Pub. Date: Jul. 23, 2009**

(54) **LIQUID CRYSTAL DISPLAY DEVICE WITH HIGH APERTURE RATIO**

Publication Classification

(76) Inventors: **Seung Ryull Park**, Gyeonggi-do (KR); **Dong Guk Kim**, Gyeonggi-do (KR)

(51) **Int. Cl.**
G02F 1/1343 (2006.01)
(52) **U.S. Cl.** 349/39

Correspondence Address:
MCKENNA LONG & ALDRIDGE LLP
1900 K STREET, NW
WASHINGTON, DC 20006 (US)

(57) **ABSTRACT**

Disclosed is an in-plane switching (IPS) mode liquid crystal display (LCD) device having an increased aperture ratio by overlapping a storage capacitor on a lower end of an electrode. The (IPS) mode liquid crystal display device (LCD) device includes first and second substrates; a gate line and a data line arranged horizontally and vertically to define a plurality of pixel regions on the first substrate; a switching device, having a gate electrode, a semiconductor layer and source and drain electrodes, at a crossing of the gate line and the data line; a passivation film on an entire surface of the first substrate including the switching device; a common electrode and a pixel electrode alternately disposed at an upper portion of the passivation film and generating an in-plane electric field, wherein at least one of the common and pixel electrodes has a first storage capacitor at its lower end; and a liquid crystal layer between the first and second substrates.

(21) Appl. No.: **12/382,421**

(22) Filed: **Mar. 16, 2009**

Related U.S. Application Data

(62) Division of application No. 11/166,094, filed on Jun. 27, 2005, now Pat. No. 7,515,237.

(30) **Foreign Application Priority Data**

Dec. 13, 2004 (KR) 10-2004-0105113

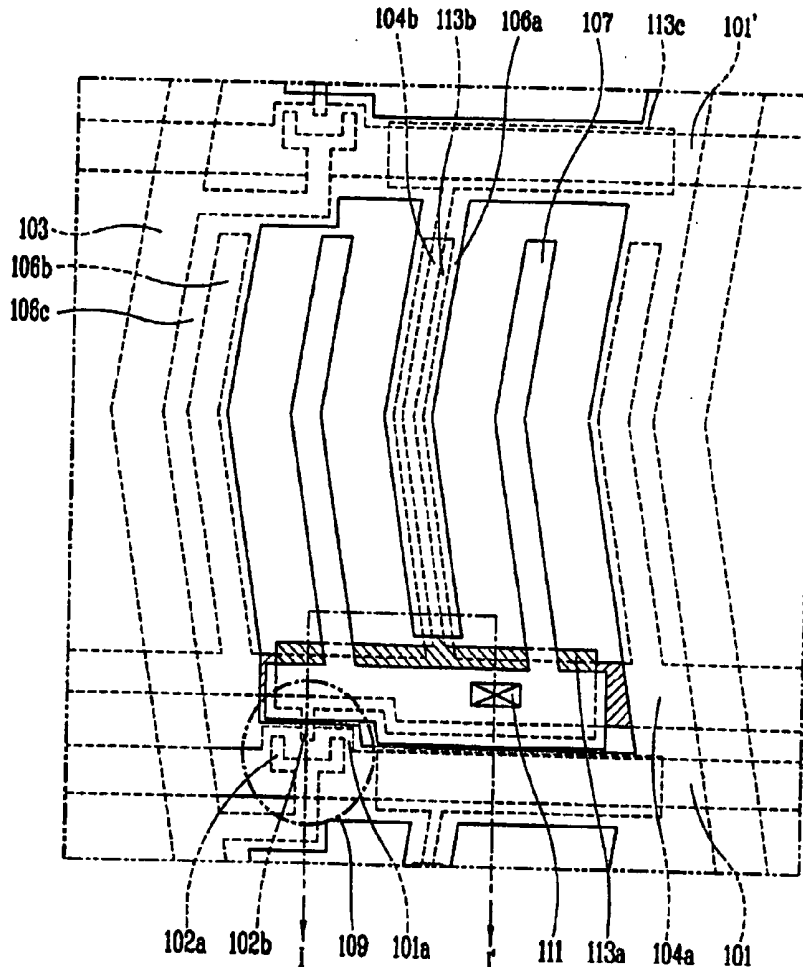

FIG. 1
RELATED ART

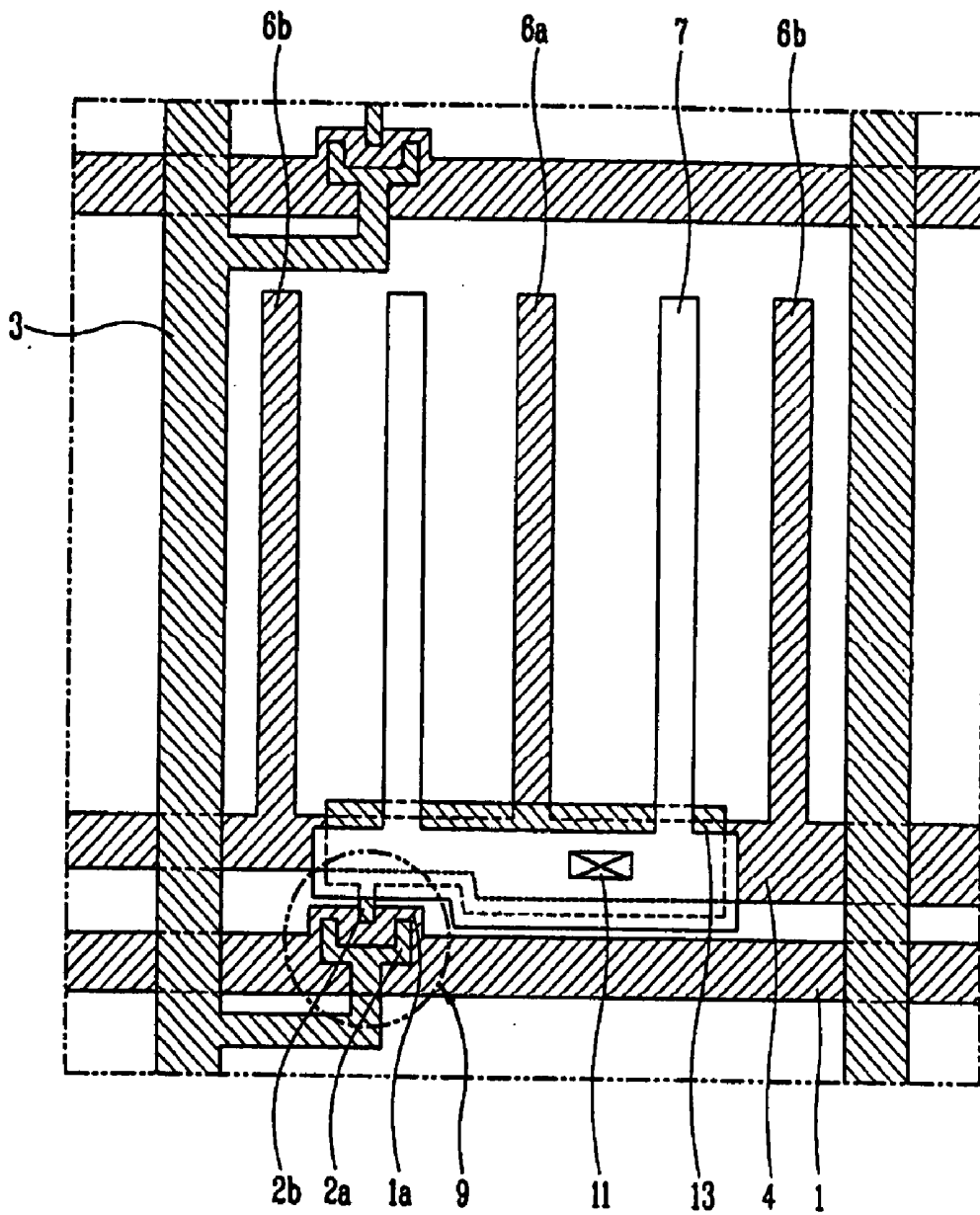

FIG. 2A

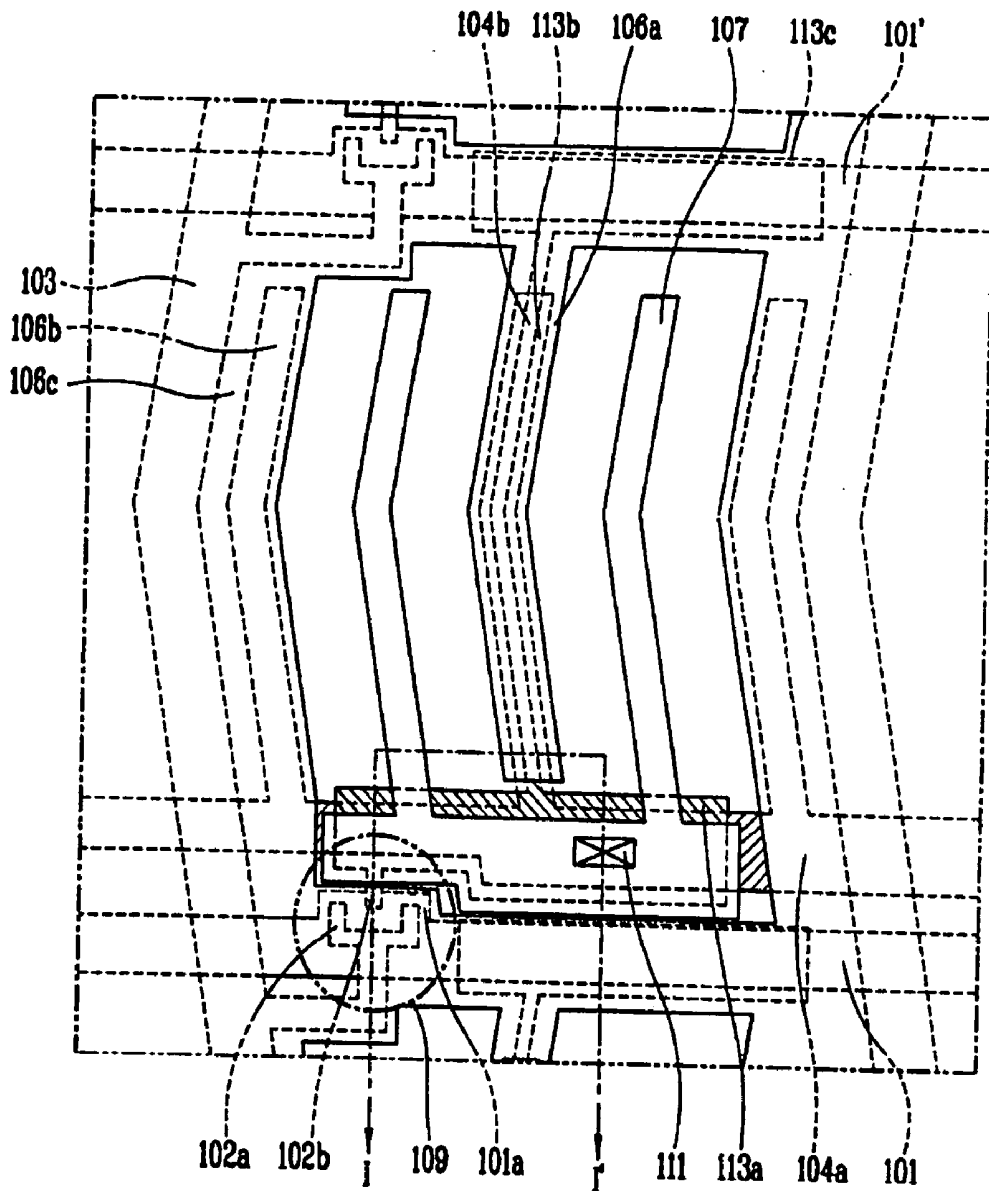

FIG. 2B

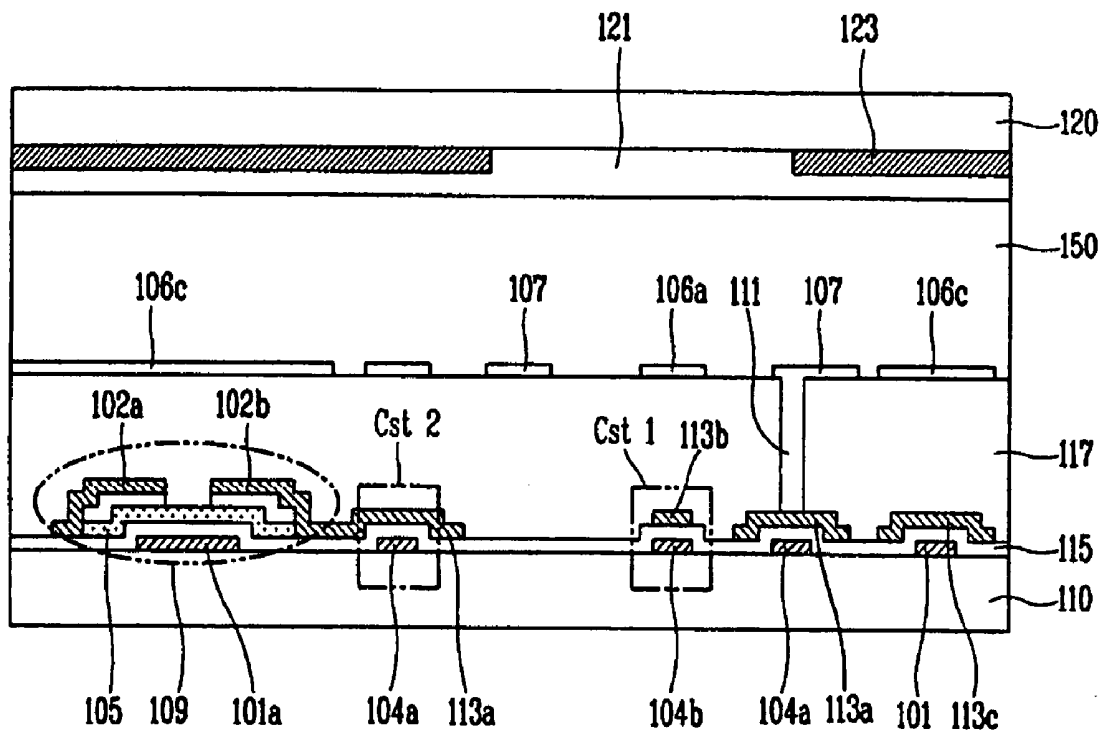

FIG. 3A

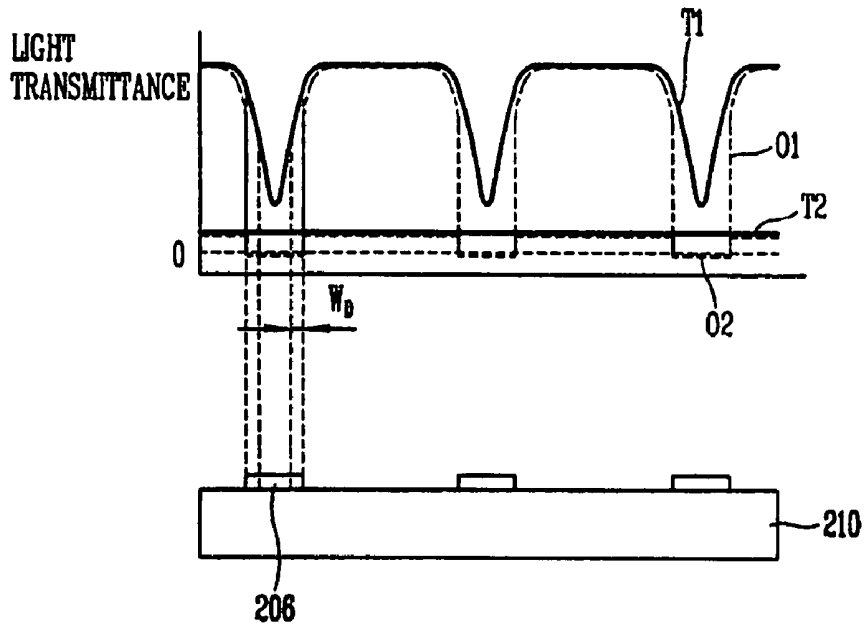

FIG. 3B

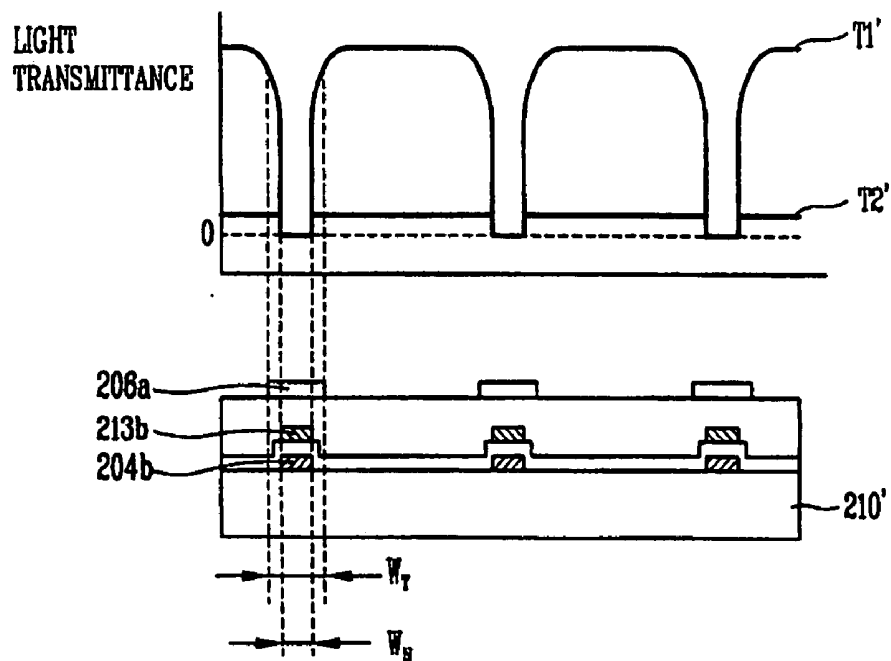

FIG. 4A

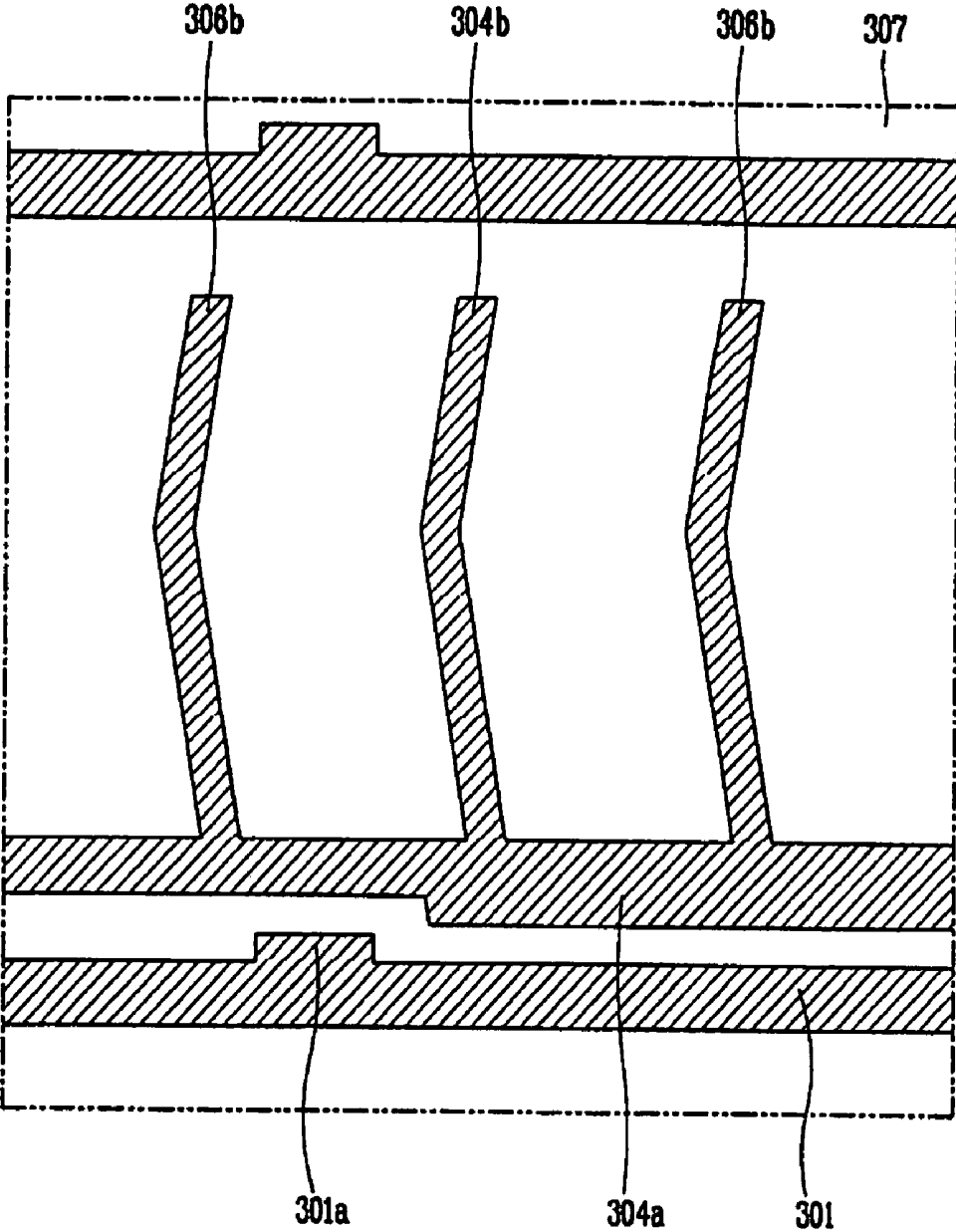
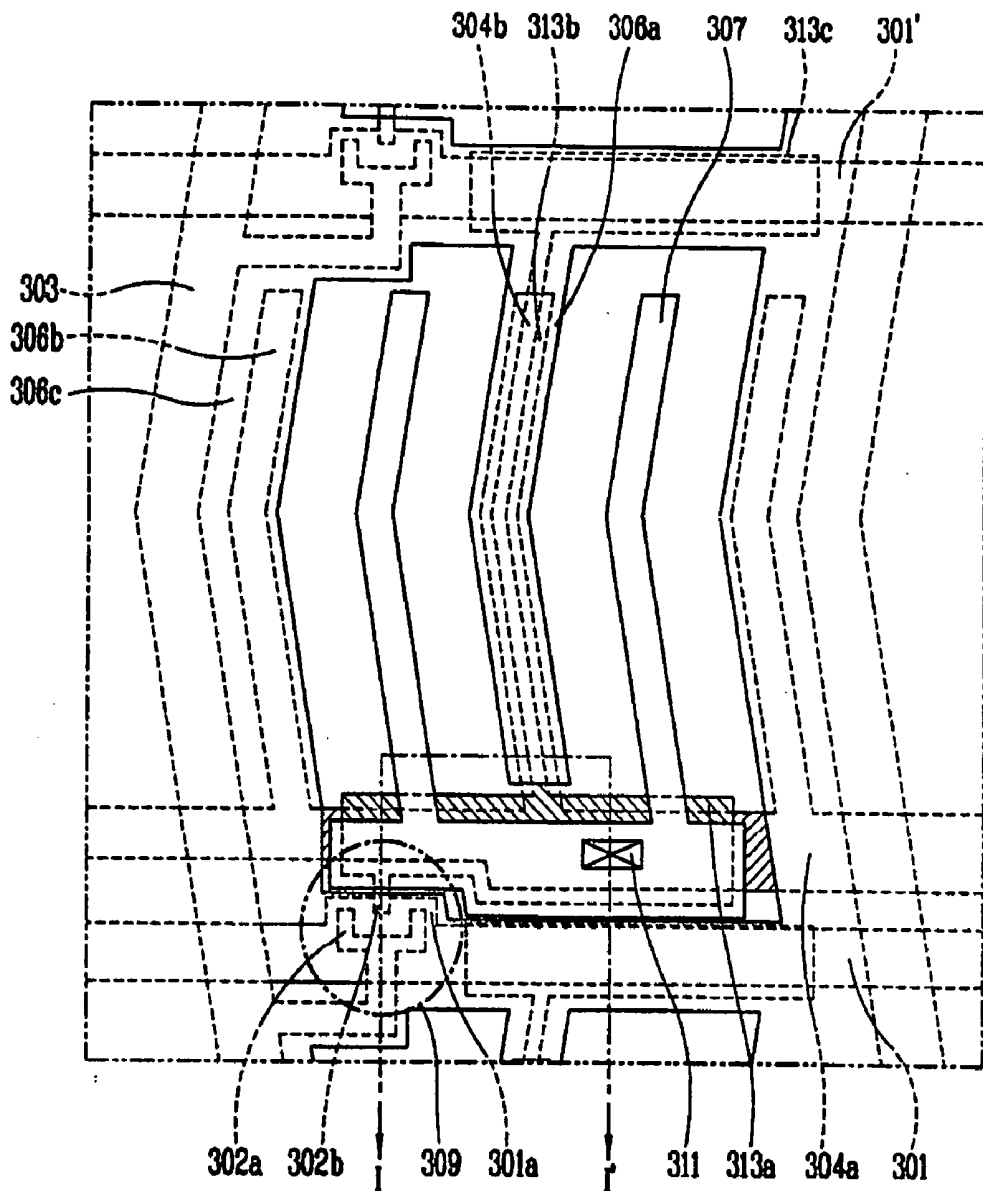

FIG. 4C



LIQUID CRYSTAL DISPLAY DEVICE WITH HIGH APERTURE RATIO

[0001] This application claims the benefit of Korean Patent Application No. 2004-105113, filed on Dec. 13, 2004, which is hereby incorporated by reference for all purposes as if fully set forth herein.

BACKGROUND OF THE INVENTION

[0002] 1. Field of the Invention

[0003] The present invention relates to a high aperture ratio liquid crystal display (LCD) device. More particularly, the present invention relates to an in-plane switching (IPS) mode LCD capable of enhancing an aperture ratio by forming a storage capacitor, namely, a light blocking region, to overlap with a lower end of at least one electrode.

[0004] 2. Description of the Related Art

[0005] As the demand for various information display devices is increasing, research for a flat panel display device such as an LCD (Liquid Crystal Display), PDP (Plasma Display Panel), an ELD (Electro Luminescent Display), an FED (Field Emission Display) or a VFD (Vacuum Fluorescent Display) is actively ongoing. Of these displays, the LCD is the most spotlighted because of its implementation of high picture quality, mass-production techniques, ease of a driving unit, light weight and thinness, and low power consumption.

[0006] The LCD device is a display device for displaying a desired image by controlling a light transmittance of a liquid crystal layer by pixels arranged in a matrix form by separately applying a data signal according to picture information of each pixel. The LCD device is commonly driven by an AM (Active Matrix) method. The AM method is a method in which a switching device such as a thin film transistor (TFT) is added in each pixel to apply a voltage to liquid crystal of each pixel in order to drive the liquid crystal.

[0007] The LCD device can be divided into various types of display mode LCD device based on how the liquid crystal molecules are driven. Among the various types of display modes, a TN (Twisted Nematic) mode LCD device has been commonly used.

[0008] The TN mode LCD device, turns on/off an electric field perpendicular to a substrate to drive liquid crystal molecules so that a director of liquid crystal can have an angle between 0° and 90° to a substrate. The TN mode LCD device has advantages of an easy black and white display function, a high speed response and a low driving voltage.

[0009] However, since the TN mode LCD device drives liquid crystal molecules to be vertical to the substrate, its viewing angle characteristics are not good. In particular, it has viewing angle dependence such that a screen color or brightness of an image changes based on a direction or an angle in or at which a user looks at a screen of the LCD device. Thus, in an effort to overcome such shortcomings, an in-plane switching (IPS) mode LCD device for driving liquid crystal to be driven in a state that a director is horizontal to the substrate is being actively studied.

[0010] In the IPS mode LCD device, when a voltage is applied to an electrode, an in-plane electric field, namely, a field having a direction parallel to the substrate, is formed to align liquid crystal molecules horizontal to the substrate to obtain wide viewing angle characteristics compared with an existing viewing angle. FIG. 1 is a schematic view of the IPS mode LCD device.

[0011] As shown, on an array substrate of the IPS mode LCD device, a gate line 1 and a data line 3 are arranged horizontally and vertically, respectively, to define a pixel region. In the pixel region, at least a pair of common electrodes 6a and 6b for switching liquid crystal molecules and a pixel electrode 7 are disposed in an alternating pattern substantially parallel to the data line 3 to generate an in-plane electric field on the array substrate.

[0012] A switching device, namely, a thin film transistor (TFT 9), which includes a gate electrode 1a, a semiconductor layer (not shown) and source and drain electrodes 2a and 2b is formed at the crossing of the gate line 1 and the data line 3, transfers a data signal to the pixel electrode 7 to switch liquid crystal molecules. The pixel electrode 7 is electrically connected with the storage electrode 13 extendedly formed from the drain electrode 2b through a first contact hole 11 to receive a signal. Also, in the pixel region, a common line 4 is formed parallel with the gate line 1 to transfer a common signal to the common electrodes 6a and 6b.

[0013] The storage electrode 13 extendedly formed from the drain electrode 2b overlaps with the common line 4 with a gate insulation film (not shown) interposed therebetween, to form a storage capacitor.

[0014] As a result, in the IPS mode LCD device having the above-described structure, the common electrodes 6a and 6b and the pixel electrode 7 generate an in-plane electric field on the array substrate to drive liquid crystal molecules in a state of being parallel with the substrate, so that the viewing angle in the up/down and left/right direction can be considerably enhanced when the display unit of the LCD device is viewed from the front side, compared with the related art TN mode LCD device.

[0015] In the IPS mode LCD device, because the common electrodes 6a and 6b and the pixel electrode 7 are disposed on the same substrate, the aperture ratio and luminance are reduced compared with the related art TN mode LCD device.

[0016] The aperture ratio is determined by a region where light of a backlight unit made incident on the liquid crystal panel cannot pass through the liquid crystal panel, namely, an area of a light blocking region. In the related art TN mode LCD device, the light blocking region is determined by a line part of the gate line and the data line applying a signal voltage, the TFT part, an extra part for considering an alignment error in bonding upper and lower substrates of the liquid crystal panel, and the part of the storage capacitor. Comparatively, in the IPS mode LCD device, a part of the common electrodes and the pixel electrode is added as the light blocking region, which reduces the aperture ratio and luminance of the LCD device.

[0017] Although the common electrodes and the pixel electrodes are formed as transparent conductors in terms of increasing white luminance of the IPS mode LCD device, in-plane electric field is substantially generated at the edge of electrodes, so the central region of the electrodes does not help to increase the aperture ratio.

SUMMARY OF THE INVENTION

[0018] Accordingly, the present invention is directed to a liquid crystal display device with high aperture ratio that substantially obviates one or more of the problems due to limitations and disadvantages of the related art.

[0019] An advantage of the present invention is to provide an LCD (Liquid Crystal Display) device capable of reducing an area ratio assumed by a light blocking region in a unit pixel

region and enhancing an aperture ratio by forming a storage capacitor, namely, a light blocking region, to overlap with a lower end of at least one electrode.

[0020] To achieve these and other advantages and in accordance with the purpose of the present invention, as embodied and broadly described herein, there is provided an in-plane switching (IPS) mode liquid crystal display device (LCD) device including: first and second substrates; a gate line and a data line arranged horizontally and vertically to define a plurality of pixel regions on the first substrate; a switching device, having a gate electrode, a semiconductor layer and source and drain electrodes, at a crossing of the gate line and the data line; a passivation film on an entire surface of the first substrate including the switching device; a common electrode and a pixel electrode arranged in an alternating pattern at an upper portion of the passivation film, wherein an in-plane electric field is generated between the common and pixel electrodes and at least one of the common and pixel electrodes has a first storage capacitor at its lower end; and a liquid crystal layer between the first and second substrates.

[0021] In another aspect of the present invention, there is provided an in-plane switching (IPS) mode liquid crystal display (LCD) device including: first and second substrates; a gate line and a data line arranged horizontally and vertically to define a plurality of pixel regions on the first substrate; a switching device, having a gate electrode, a semiconductor layer and source and drain electrodes, at a crossing of the gate line and the data line; at least one metal layer on a same layer of the gate line; a first storage electrode overlapping the metal layer to form a first storage capacitor; a passivation film on an entire surface of the first substrate including the switching device and the first storage electrode; a common electrode and a pixel electrode arranged in an alternating pattern at an upper portion of the passivation film in the pixel region and generating an in-plane electric field, wherein at least one of the common and pixel electrodes has the first storage capacitor at its lower portion; and a liquid crystal layer formed between the first and second substrates.

[0022] In another aspect of the present invention, there is also provided a method for fabricating an in-plane switching (IPS) mode liquid crystal display (LCD) device including: preparing first and second substrates; forming at least one first storage capacitor on the first substrate; forming a passivation film on the first substrate with at least one first storage capacitor formed thereon; forming a common electrode and a pixel electrode at a region on the passivation film corresponding to the first storage capacitor; and forming a liquid crystal layer between the first and second substrates.

[0023] It is to be understood that both the foregoing general description and the following detailed description are exemplary and explanatory and are intended to provide further explanation of the invention as claimed.

BRIEF DESCRIPTION OF THE DRAWINGS

[0024] The accompanying drawings, which are included to provide a further understanding of the invention and are incorporated in and constitute a part of this specification, illustrate embodiments of the invention and together with the description serve to explain the principles of the invention.

In the drawings:

[0025] FIG. 1 is a plan view showing a unit pixel region of an in-plane switching (IPS) mode liquid crystal display (LCD) device in accordance with the related art;

[0026] FIG. 2A is a plan view showing a unit pixel region of an IPS mode LCD device in accordance with an embodiment of the present invention;

[0027] FIG. 2B is a sectional view taken along line I-I' of FIG. 2A;

[0028] FIGS. 3A and 3B are graphs showing light transmittance characteristics according to an electrode formation material and an electrode structure of the LCD device in accordance with the present invention; and

[0029] FIGS. 4A to 4C are plan views showing a sequential fabrication process of the IPS mode LCD device in accordance with the present invention.

DETAILED DESCRIPTION OF THE ILLUSTRATED EMBODIMENTS

[0030] An IPS mode LCD device with a high aperture ratio in accordance with the present invention will now be described with reference to the accompanying drawings.

[0031] FIG. 2A is a plan view showing a unit pixel region of an IPS mode LCD device in accordance with the present invention, and FIG. 2B is a sectional view taken along line I-I' of FIG. 2A.

[0032] As illustrated, a gate line **101** and a data line **103** are arranged horizontally and vertically on a first substrate **110** to define a pixel region, and at a crossing of the gate line **101** and the data line, there are formed a gate electrode **101a** formed as a portion of the gate line **101**, a semiconductor layer **105** formed on the gate electrode **101a** and source and drain electrodes **102a** and **102b** disposed spaced apart from each other on the semiconductor layer **105** to form a switching device **109**.

[0033] A passivation film **117** made of an organic insulation film with a low dielectric constant is deposited on the entire surface of the first substrate **110** including the gate line **101**, the data line **103** and the switching device **109**, on which at least a pair of common electrode **106a** and pixel electrode **107** made of a transparent conductor of ITO (Indium Tin Oxide), IZO (Indium Zinc Oxide), ITZO (Indium Tin Zinc Oxide) or TO (Tin Oxide) are alternately formed substantially parallel to each other to generate an in-plane electric field on the first substrate **110**. The pixel electrode **107** receives a data signal of the drain electrode **102b** through a first contact hole **111** formed on the passivation film **117**.

[0034] A first storage capacitor **Cst1** is formed at a lower end of the common electrode **106a**.

[0035] As for the first storage capacitor **Cst1**, at least one metal layer **104b** formed on the same layer as the gate line **101** and the first storage electrode **113b** formed on the same layer as the data line **103** are disposed to overlap with each other with a gate insulation film **115** interposed therebetween. In this case, the metal layer **104b** is formed by extending a portion of the common line **104a** for transferring a common signal, and the first storage electrode **113b** is formed by extending the drain electrode **102b** made of a metal.

[0036] The first storage capacitor **Cst1** charges a pixel voltage while a gate signal is being applied to the gate electrode **101a**, and supplies the charged pixel voltage to the pixel electrode **107** until the next gate signal is applied, namely, until the switching device **109** of the next pixel is turned on again, so that flicker due to change of a voltage of the pixel electrode **107** can be prevented and alignment of liquid crystal can be maintained.

[0037] As mentioned above, the passivation film **117** is interposed between the first storage capacitor **Cst1** and the

common electrode **106** disposed at an upper portion of the first storage capacitor **Cst1**. The passivation film **117** is made of an organic insulation material with a low dielectric constant such as acrylic resin, BCB (Benzocyclobutene) and a polyimide resin in order to prevent formation of parasitic capacitance between the first storage capacitor **Cst1** and the common electrode **106a**. For the same reason, in the present invention, the first storage capacitor **Cst1** can be formed at a lower end of the pixel electrode without limitation in its number as well as formed at the lower end of the common electrode.

[0038] In the pixel region in accordance with the present invention, besides the first storage capacitor **Cst1** formed at the lower end of the electrode, second and third storage capacitors can be additionally formed. Namely, by overlapping a second storage electrode **113a** formed as a portion of the drain electrode **102b** extends at an upper portion of the common line **104a**, to form the second storage capacitor **Cst2** together with the common line **104b**. In addition, by overlapping a third storage electrode **113c** formed as a portion of the first storage electrode **113b** extends with a gate line **101'** of a neighbor pixel, to form the third storage capacitor. In this case, the third storage capacitor includes a previous gate line **101'**, so that when the previous gate line **101'** is turned on, a storage capacitor of a pixel corresponding to the next gate line **101** can be charged in advance.

[0039] The first storage capacitor **Cst1** is formed to be narrow in its width compared with the common electrode **106a** (or the pixel electrode **107**) disposed at its upper portion. In other words, the first storage electrode **113b** and the metal layer **104b** forming the first storage capacitor **Cst1** are formed at a lower end of the central portion except for an edge region of the common electrode **106a**. With this structure of the LCD device, an excellent screen contrast ratio can be implemented and degradation of the aperture ratio due to the area occupied by the storage capacitor in the pixel region can be minimized.

[0040] FIGS. 3A and 3B are graphs showing light transmittance characteristics according to electrode formation material and an electrode structure of the LCD device in accordance with the present invention.

[0041] FIG. 3A shows light transmittance in a normal white mode and a normal black mode for a case where all the electrodes **206** formed on the substrate **210** are made of a transparent conductor and for a case where all the electrodes **206** formed on the substrate **210** are made of an opaque conductor.

[0042] In FIG. 3A, solid lines **T1** and **T2** indicate, respectively, light transmittance in the normal white mode and in the normal black mode when the electrodes **206** are all made of the transparent conductor in the IPS mode LCD device, and dotted lines **01** and **02** indicate, respectively, light transmittance in the normal white mode and in the normal black mode when the electrodes **206** are all made of the opaque conductor (e.g., metal) in the IPS mode LCD device.

[0043] First, when the electrodes **206** formed on the substrate **210** are all made of the opaque conductor, light cannot be transmitted at the upper region of the electrode **206** in both normal black mode and normal white mode, resulting in the light transmittance **01** and **02** at the upper portion of the electrode **206** is 0. In comparison, when the electrodes **206** are all made of the transparent conductor, light is partially leaked at the upper portion of the electrode **206** in the normal black mode, failing to implement complete black luminance over the entire region of the substrate **210** including the electrode

206. Namely, in the case that the electrodes **206** are made of the transparent conductor, light transmittance **T2** at the upper portion of the electrode **206** increases by a certain numerical value.

[0044] Meanwhile, in the normal white mode, liquid crystal is driven at a certain region of the upper portion of the electrode **206**, a bit of light is transmitted to have a light transmittance **T1** having a parabolic shape as shown in the drawing. Namely, black luminance and white luminance of the LCD device increase.

[0045] In this respect, however, it should be noted that a region for bettering the aperture ratio substantially in the normal white mode, among the entire area of the upper portion of the electrode **206**, is limited to the edge portion (WD) of the electrode **206**. In other words, the central portion of the electrode **206** except for the edge portion (WD) does not affect an increase of the white luminance and the aperture ratio. This is because in terms of the characteristics of the IPS mode LCD device, an in-plane electric field for driving liquid crystal is not substantially generated from the upper portion (especially at the central portion of the electrode) of the electrode. Thus, the central portion of the electrode works as a light blocking region.

[0046] Thus, by using the area of the central portion of the electrode, which is no better than the light blocking region, among the entire area of the electrode made of the transparent conductor, the first storage capacitor made of the opaque metal is disposed on the corresponding region, whereby the area occupied by the light blocking region in the unit pixel region can be reduced and the aperture ratio of the LCD device can be enhanced.

[0047] FIG. 3B shows light transmittance characteristics of each region of a substrate **210'** when the first storage capacitor, namely, an opaque metal layer **204b** and a first storage electrode **213b**, are disposed at a lower side of an electrode **206a** made of a transparent conductor in the IPS mode LCD device.

[0048] As illustrated, the edge portion (WN) (namely, the portion other than the central portion (WT) of the electrode **206a**) of the transparent electrode **206a** has a highly increasing light transmittance and has an enhanced aperture and luminance likewise in FIG. 3A. Meanwhile, at the central portion (WT) of the electrode **206a**, namely, the corresponding region of the metal layer **204b** and the first storage electrode **213b**, each transmittance (**T1'** and **T2'**) is 0 in the normal black mode and normal white mode, implementing the complete black luminance. Thus, a screen contrast ratio can be increased.

[0049] Actually, in a state that the factors for determining the aperture ratio in the unit pixel region, namely, the width of the gate line and the data line, the size of the TFT, the extra portion in consideration of an alignment error in bonding upper and lower substrates of the liquid crystal panel and the value of the storage capacitance, comparison between the aperture ratio of the LCD device of the present invention and that of the related art shows that the aperture ratio of the LCD device of the present invention is much higher than that of the related art.

[0050] That is, in the present invention, since the first storage capacitor is formed at the lower end of the central portion of the electrode, which substantially corresponds to the light blocking region, the advantages of the aperture ratio and luminance when the common electrode and the pixel electrode are made of the transparent conductor can be main-

tained, and in addition, since the storage capacitor, which corresponds to the light blocking region in the pixel region in the related art, overlaps with the lower end of the central portion of the electrode, that is, another light blocking region, the area occupied by the light blocking region in the pixel region can be reduced. Thus, a LCD device with a high aperture ratio can be obtained. By doing that, final luminance of the LCD device can be increased or power consumption of the LCD module for achieving the same final luminance can be reduced. In addition, the screen contrast ratio that can be obtained when the common electrode and the pixel electrode are made of an opaque conductor can be obtained.

[0051] Subsequently, with reference to FIGS. 2A and 2B, in the LCD device, a portion of a common line 104a extends to form a shielding line 106b along an edge portion of the unit pixel region. The shielding line 106b is disposed to be substantially parallel with the data line 103 to cut off a data signal of the data line 103. In this case, the shielding line 106b can have a wider width than the common electrode 106a formed at the center of the pixel in order to effectively prevent signal interference between the data line 103 and the pixel electrode 107.

[0052] The common electrode 106a and the pixel electrode 107 are formed in a '<' (bent) shape based on the extended direction of the gate line 101, and the data line 103 may also have the same '<' (bent) shape substantially parallel to the common electrode 106a and the pixel electrode 107. In this case, the common electrode 106a, the pixel electrode 107 and the data line 103 may have a '>' (bent) shape or a horizontally straight (short) line. The common electrode 106a and the pixel electrode 107 may be disposed to be substantially parallel with the gate line 101 and bent with respect to a longitudinal direction of the data line 103.

[0053] The transparent conductor forming the common electrode can extend to an upper portion of the gate line, the data line, the TFT and the shielding line to form a transparent conductor layer 106c, whereby signal distortion due to a residual voltage between the data line and the pixel electrode 107 can be prevented and light leakage to the upper portion of the gate line 101, the data line 103, the TFT 109 and the shielding line 106b can be prevented.

[0054] FIG. 2B shows the first substrate 110 as shown in FIG. 2A, the second substrate 120 corresponding to the first substrate 110 and a liquid crystal layer 150 formed between the first and second substrates 110 and 120.

[0055] As shown, on the transparent second substrate 120, there are formed color filters 121 for implementing R, G and B colors and a black matrix 123 formed at the boundary among color filters 121 and blocking a portion of light transmitting through the liquid crystal layer 150. The color filter 121 can also be formed on the first substrate 110.

[0056] A method of fabricating the IPS mode LCD device with a high aperture ratio in accordance with the present invention will now be described with reference to the accompanying drawings.

[0057] FIGS. 4A to 4C are plan views showing a sequential fabrication process of the IPS mode LCD device in accordance with the present invention.

[0058] As shown in FIG. 4A, a transparent first substrate 307 made of glass, quartz or the like is prepared, on which a first metallic material, such as molybdenum (Mo), a molybdenum alloy, aluminum (Al), an aluminum alloy, titanium

(Ti), a titanium alloy, tantalum (Ta), a tantalum alloy, Cobalt, a cobalt alloy, nickel (Ni), a nickel alloy, Copper (Cu) or a copper alloy, is deposited.

[0059] Next, the resulting structure is patterned to form the gate line 301, the gate electrode 301a, the common line 304a and at least one metal layer 304b and shielding line 306b extending from the common line 304a. The metal layer 304b and the shielding line 306b are disposed to be substantially perpendicular to an extended direction of the gate line 301.

[0060] Next, an inorganic material such as SiNx (Silicon Nitride) or SiOx (Silicon Oxide) is deposited on the entire surface of the first substrate 307 including the gate line 301 and the common line 304a using a plasma CVD (Chemical Vapor Deposition) method to form a gate insulation film (not shown).

[0061] Thereafter, as shown in FIG. 4B, amorphous silicon and n+ amorphous silicon are sequentially deposited at an upper portion of the gate insulation film and then patterned to form a semiconductor layer (not shown) on the gate electrode 301a.

[0062] Subsequently, a second metal material, such as molybdenum (Mo), a molybdenum alloy, aluminum (Al), an aluminum alloy, titanium (Ti), a titanium alloy, tantalum (Ta), a tantalum alloy, cobalt, a cobalt alloy, nickel (Ni), a nickel alloy, copper (Cu) or a copper alloy, is deposited on the entire surface of the substrate including the semiconductor layer and then patterned to form a data line 303 defining a pixel region together with the gate line 301 and source and drain electrodes 302a and 302b disposed spaced apart from the semiconductor layer. In this case, a portion of the drain electrode 302b extends to an upper portion of the common line 304a to form a second storage electrode 313a. One side of the second storage electrode 313a extends to an upper portion of the metal layer 304b to form a first storage electrode 313b, and then, the first storage electrode 313b extends to overlap with an upper portion of the previous gate line 301' to form a third storage electrode 313c.

[0063] The first storage electrodes 313b are formed as many as the metal layers 304b so that they can correspond to each other.

[0064] Thereafter, a transparent organic material with a low dielectric constant such as an acrylic resin, a BCB (Benzocyclobutene) and a polyimide resin is coated on the entire surface of the substrate including the data line 303, the source and drain electrodes 302a and 302b, and the first to third storage electrodes 313b, 313a and 313c, to form a passivation film (not shown).

[0065] Subsequently, as shown in FIG. 4C, the passivation film (not shown) is patterned to form a first contact hole 311 exposing one side of the drain electrode 302b or the second storage electrode 313a, and at the same time, to form a second contact hole (not shown) exposing a portion of the common line 304a to which a common signal of a pad terminal part (not shown) is applied.

[0066] And then, a transparent conductor such as ITO (Indium Tin Oxide), IZO (Indium Zinc Oxide), ITZO (Indium Tin Zinc Oxide) or TO (Tin Oxide) is deposited on the passivation film and then patterned to form a common electrode 306a and a pixel electrode 307 generating an in-plane electric field on the substrate, and a transparent conductor layer 306c extends from the common electrode 306a to cover the upper portion of the gate line 301, the data line 303, the switching device 309 and the shielding line 306b. In this case, the common electrode 306a and the pixel electrode 307 are

formed at a certain region on the passivation film (not shown) corresponding to a first storage capacitor Cst1.

[0067] Through the above process, the array substrate of the IPS mode LCD device in accordance with the present invention is fabricated.

[0068] Additionally, though not shown, the method for fabricating the LCD device in accordance with the present invention includes: preparing a transparent second substrate; forming a black matrix and a color filter on the second substrate; and bonding the first and second substrates through the above-described process, and forming a liquid crystal layer at a space between the first and second substrates.

[0069] As so far described, the IPS mode LCD device with a high aperture ratio and its fabrication method in accordance with the present invention have many advantages.

[0070] For example, because the first storage capacitor is disposed at the lower end of the central portion of the common electrode and the pixel electrode, namely, the substantial light blocking region, reduction of the aperture ratio can be prevented while obtaining the same storage capacitance as that of the related art LCD device.

[0071] The first storage capacitor is not limited to necessarily being positioned at the lower end of the common electrode, and the number of first storage capacitors is not limited at its formation at the lower end of the pixel electrode. This can be possible because the passivation film with a low dielectric constant is disposed between the common electrode, the pixel electrode and the first storage capacitor to prevent generation of parasitic capacitance. In addition, the common electrode and the pixel electrode generating an in-plane electric field can be made of an opaque metal material, not the transparent conductor.

[0072] It will be apparent to those skilled in the art that various modifications and variation can be made in the present invention without departing from the spirit or scope of the invention. Thus, it is intended that the present invention cover the modifications and variations of this invention provided they come within the scope of the appended claims and their equivalents.

1-17. (canceled)

18. An in-plane switching (IPS) mode liquid crystal display (LCD) device, comprising:

- first and second substrates;
- a gate line and a data line arranged horizontally and vertically to define a plurality of pixel regions on the first substrate;
- a switching device, having a gate electrode, a semiconductor layer and source and drain electrodes, at a crossing of the gate line and the data line;
- at least one metal layer on a same layer of the gate line;
- a first storage electrode overlapping the metal layer to form a first storage capacitor;
- a passivation film on an entire surface of the first substrate including the switching device and the first storage electrode;
- a common electrode and a pixel electrode arranged an alternating pattern at an upper portion of the passivation film in the pixel region and generating an in-plane electric field, wherein at least one of the common and pixel electrodes has the first storage capacitor at its lower portion; and
- a liquid crystal layer between the first and second substrates.

19-20. (canceled)

* * * * *

专利名称(译)	具有高孔径比的液晶显示装置		
公开(公告)号	US20090185092A1	公开(公告)日	2009-07-23
申请号	US12/382421	申请日	2009-03-16
[标]申请(专利权)人(译)	朴升RYULL 金东GUK		
申请(专利权)人(译)	朴升RYULL 金东GUK		
当前申请(专利权)人(译)	LG DISPLAY CO. , LTD.		
[标]发明人	PARK SEUNG RYULL KIM DONG GUK		
发明人	PARK, SEUNG RYULL KIM, DONG GUK		
IPC分类号	G02F1/1343		
CPC分类号	G02F1/136213 G02F1/134363		
优先权	1020040105113 2004-12-13 KR		
其他公开文献	US8031279		
外部链接	Espacenet USPTO		

摘要(译)

公开了一种面内切换 (IPS) 模式液晶显示 (LCD) 装置, 其通过在电极的下端重叠存储电容器而具有增加的孔径比。(IPS) 模式液晶显示装置 (LCD) 装置包括第一和第二基板; 栅极线和数据线水平和垂直排列, 以在第一基板上形成多个像素区域; 开关器件, 具有栅电极, 半导体层以及源电极和漏电极, 位于栅极线和数据线的交叉处; 在包括开关器件的第一基板的整个表面上的钝化膜; 公共电极和像素电极交替地设置在钝化膜的上部并产生面内电场, 其中公共电极和像素电极中的至少一个在其下端具有第一存储电容器; 以及第一和第二基板之间的液晶层。

