



US 20080309838A1

(19) **United States**

(12) **Patent Application Publication**
FUKUOKA et al.

(10) **Pub. No.: US 2008/0309838 A1**
(43) **Pub. Date: Dec. 18, 2008**

(54) **LIQUID CRYSTAL DISPLAY DEVICE**

(30) **Foreign Application Priority Data**

(75) Inventors: **Nobuko FUKUOKA**, Saitama-shi (JP); **Arihiro TAKEDA**, Saitama-shi (JP); **Tetsuya IIZUKA**, Saitama-shi (JP); **Hirokazu MORIMOTO**, Fukaya-shi (JP)

Jun. 12, 2007 (JP) 2007-155039

Publication Classification

(51) **Int. Cl.**
G02F 1/1339 (2006.01)
G02F 1/133 (2006.01)
(52) **U.S. Cl.** **349/39; 349/155**

Correspondence Address:

OBLON, SPIVAK, MCCLELLAND MAIER & NEUSTADT, P.C.
1940 DUKE STREET
ALEXANDRIA, VA 22314 (US)

(57) **ABSTRACT**

The present invention regarding a liquid crystal display device aims to further prevent generation of low-temperature bubbles in a uniform cell gap and to further improve strength against pressure applied to a glass surface while saving a production cost. A liquid crystal display device according to the present invention includes multiple spacers arranged on a liquid crystal layer side of an array substrate. The multiple spacers include: a first spacer arranged in a part of an insulating layer having no contact hole formed thereon; and a second spacer arranged inside of the contact hole. The contact hole is provided on the insulating layer and connects a switching element to either a corresponding pixel electrode or a corresponding auxiliary capacitive layer.

(73) Assignee: **Toshiba Matsushita Display Technology Co., Ltd.**, Tokyo (JP)

(21) Appl. No.: **12/111,475**

(22) Filed: **Apr. 29, 2008**

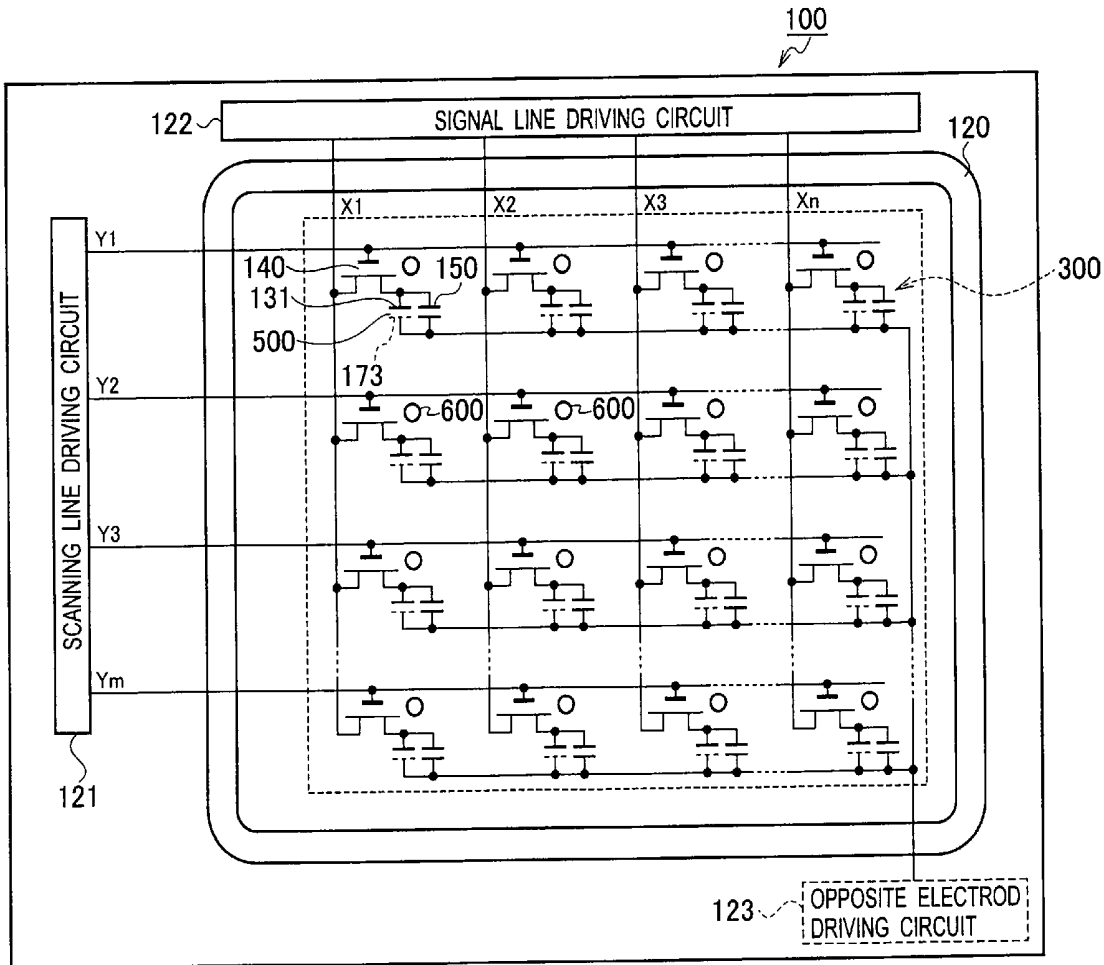

FIG. 1
100

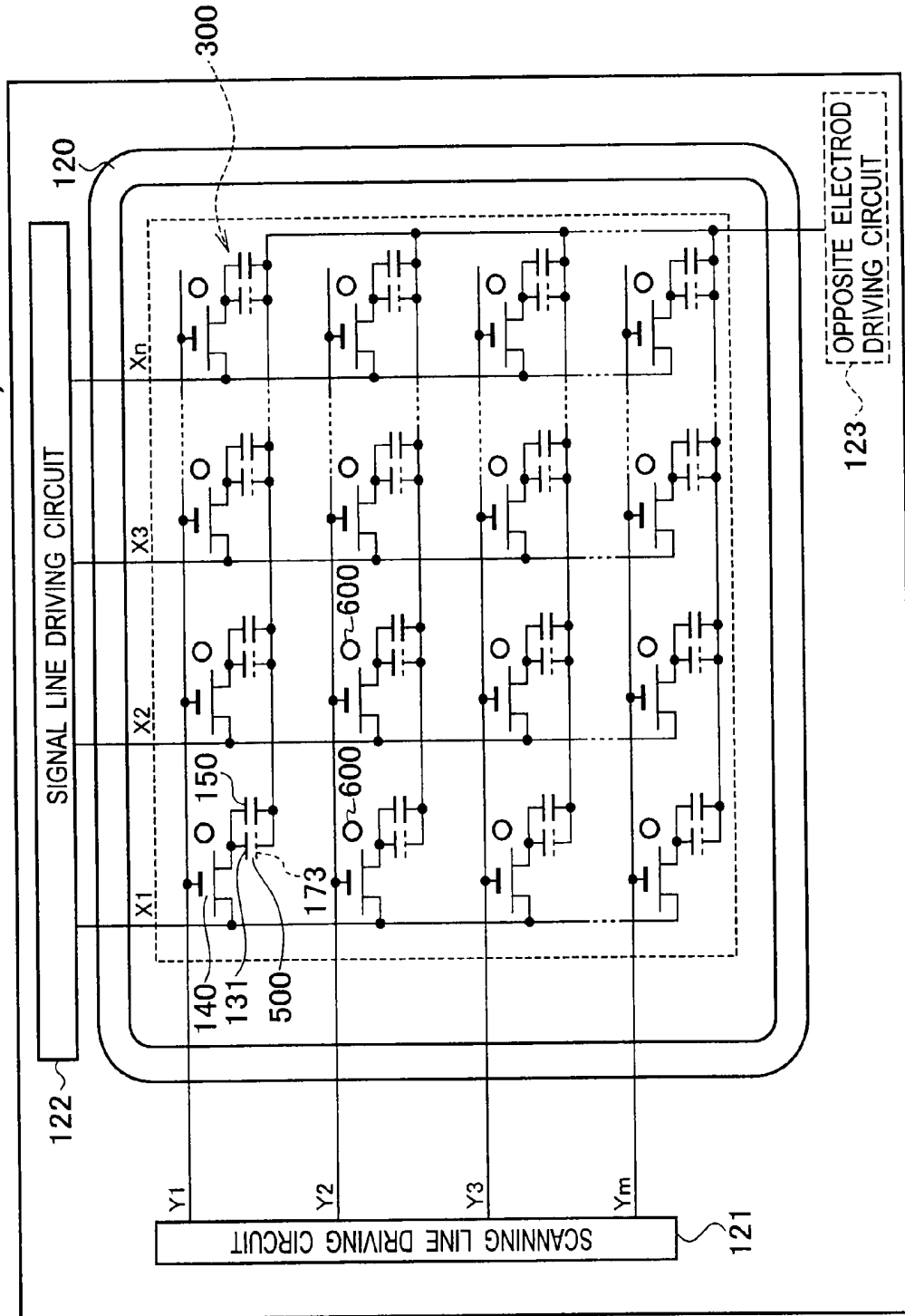

FIG. 2

200

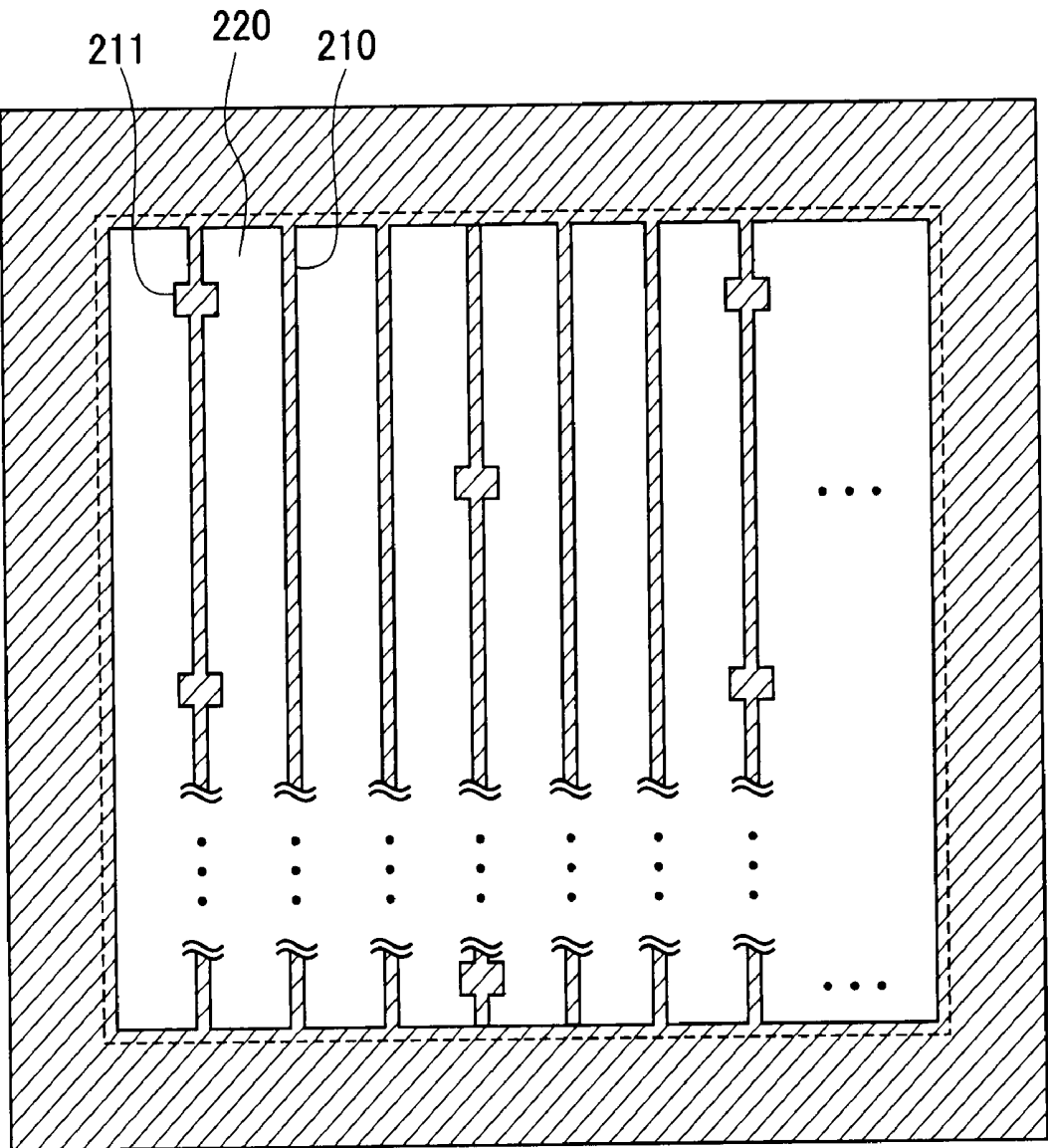

FIG. 3

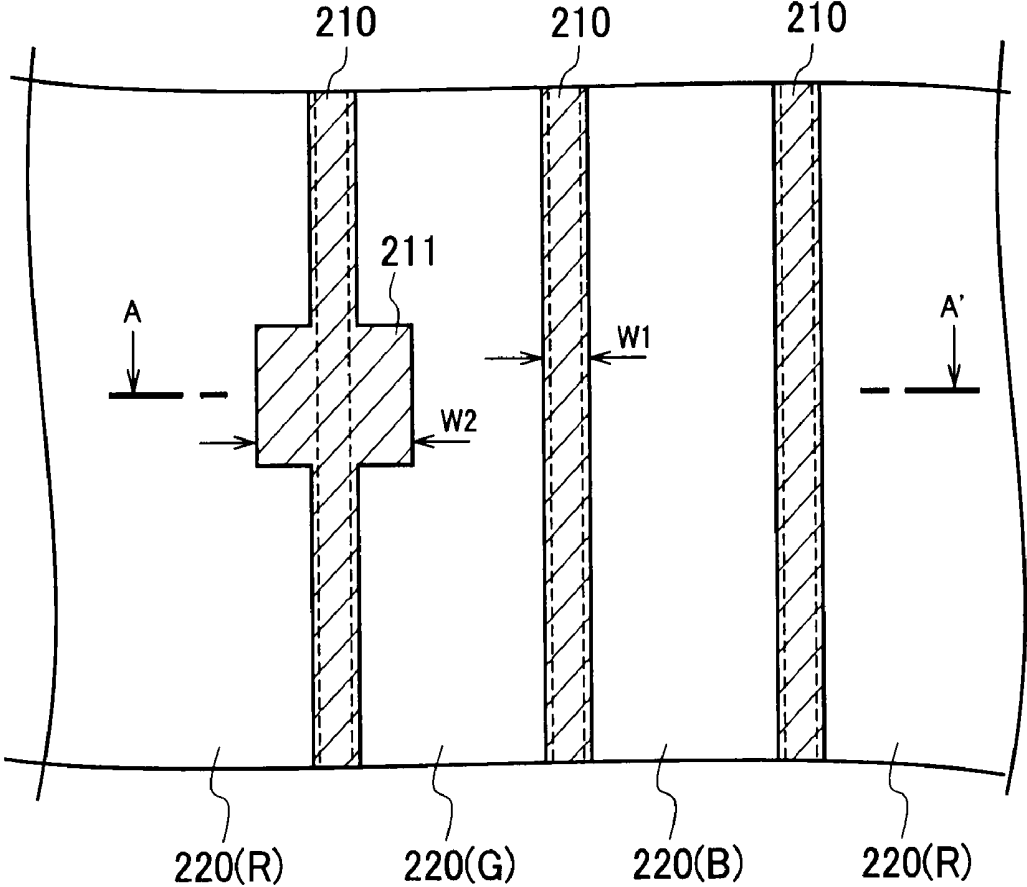

FIG. 4

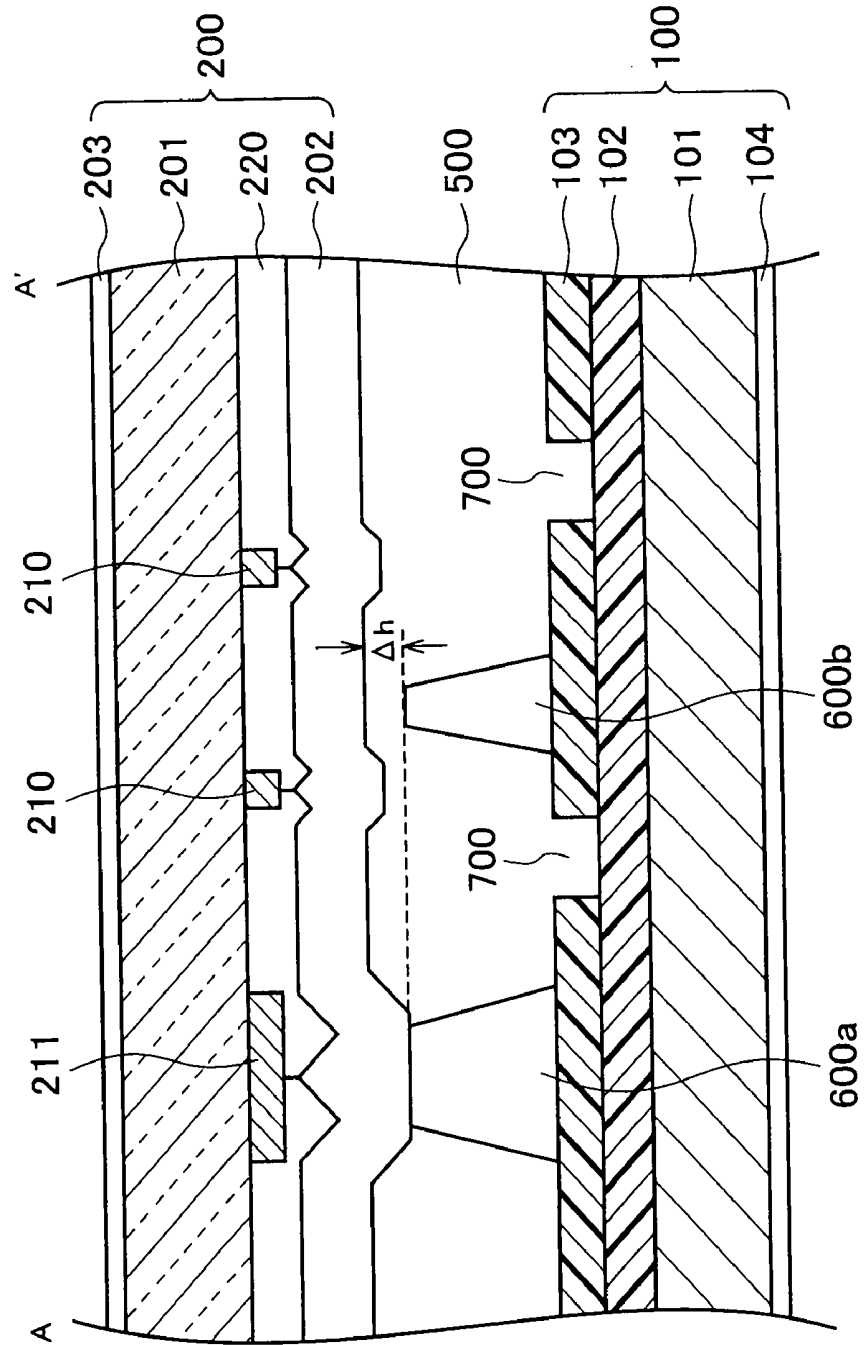



FIG. 5

300



-  FIRST PILLAR SPACER
-  SECOND PILLAR SPACER

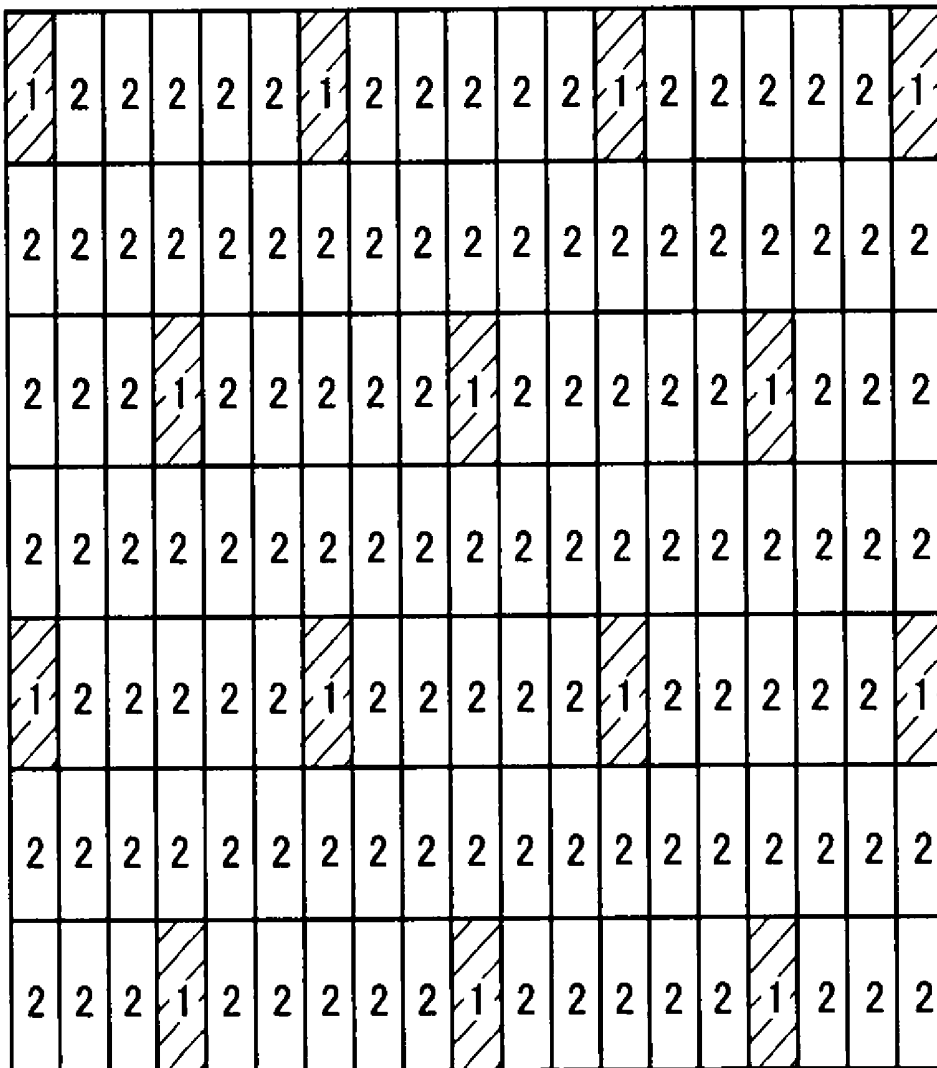

FIG. 6

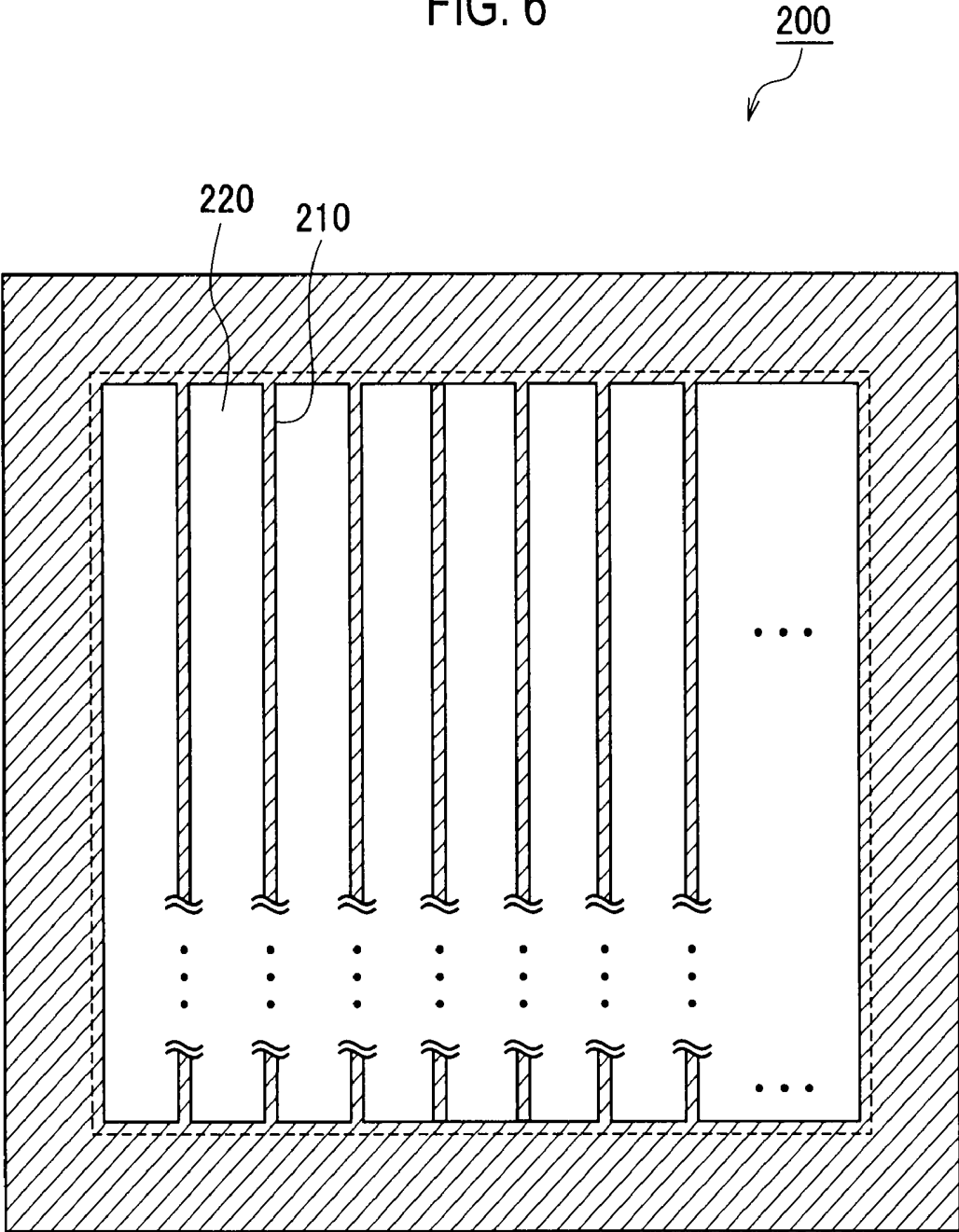

FIG. 7

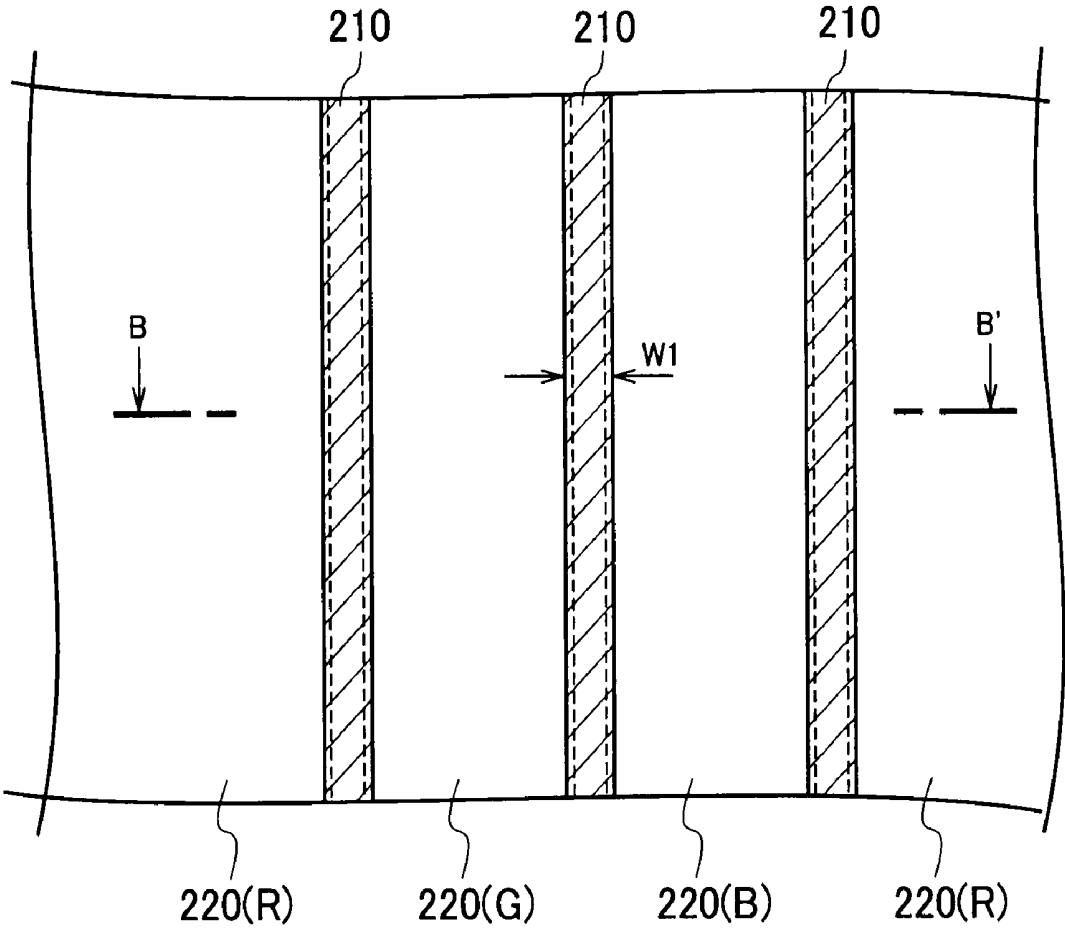
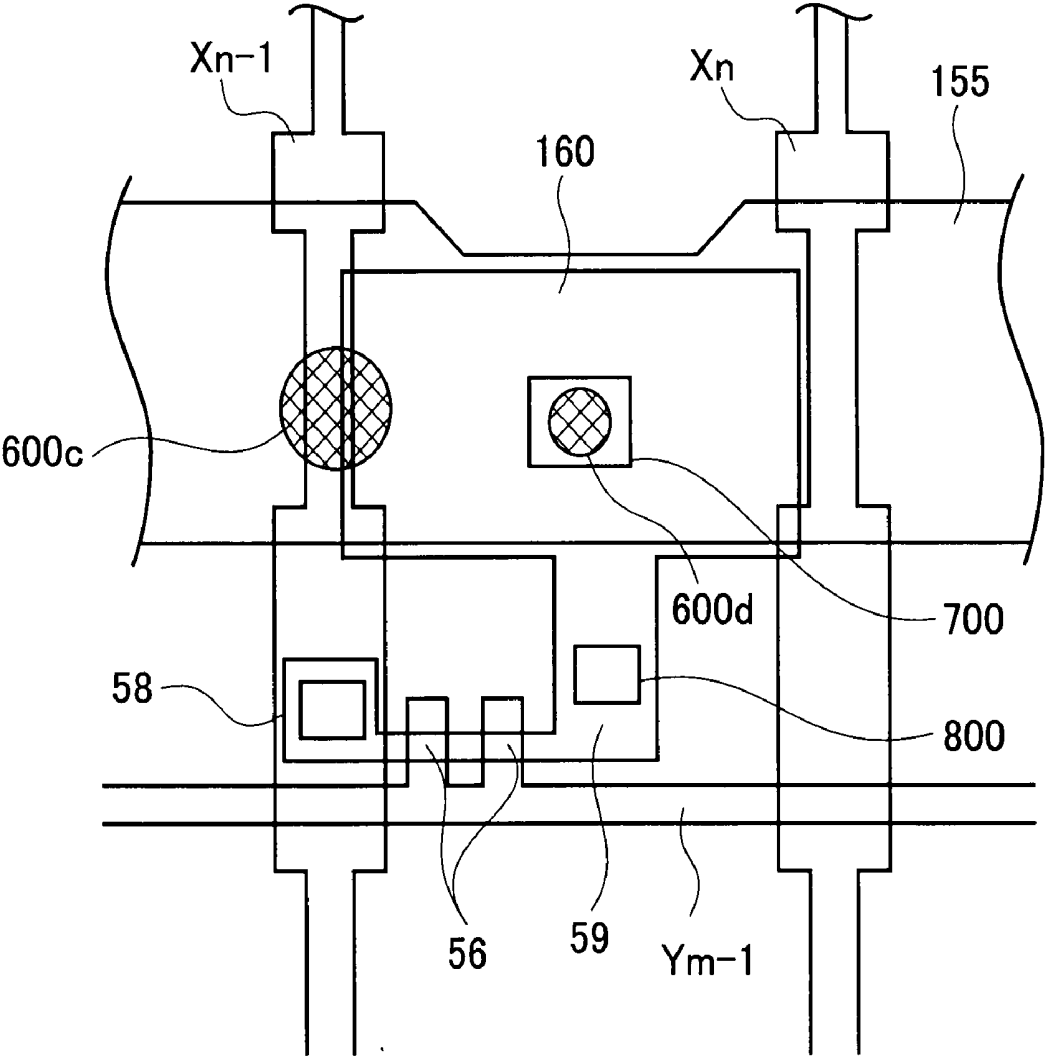

FIG. 9



LIQUID CRYSTAL DISPLAY DEVICE

CROSS-REFERENCE TO RELATED APPLICATIONS

[0001] This application is based upon and claims the benefit of priority from Japanese Patent Application No. 2007-155039 filed on Jun. 12, 2007; the entire contents of which are incorporated herein by reference.

BACKGROUND OF THE INVENTION

[0002] 1. Field of the Invention

[0003] The present invention relates to a liquid crystal display device and, in particular, to a liquid crystal display device in which spacers having a uniform height are provided on a substrate.

[0004] 2. Description of the Related Art

[0005] In the recent years, research has been conducted to promote practical application of a liquid crystal display device which not only has a high density and a high capacity but also is capable of providing high performance and displaying high-definition images. There are various types of such a liquid crystal display device available. Among others, an active matrix-type liquid crystal display device has been widely used for several reasons, such as that crosstalk between adjacent pixels is small, a high-contrast image can be obtained, images can be displayed in the transmissive mode, and the display area can easily be made larger. In this active matrix-type liquid crystal display device, a thin film transistor (TFT) as a switching element and a pixel electrode are provided on an array substrate at each of intersections between multiple scanning lines and multiple signal lines which are arranged so as to intersect with each other.

[0006] Liquid crystal display devices are commonly provided with spacers for obtaining a uniform gap between an array substrate and an opposite substrate facing the array substrate. There are spherical and pillar spacers. The spherical spacer is applied in a production process for pasting the array substrate and the opposite substrate together. The pillar spacer is formed integrally either on the array substrate or the opposite substrate by the photolithographic method in a production process of the substrate. Since the pillar spacer can be arranged in the vicinity of the intersections between the scanning lines and the signal lines without overlapping with pixel electrodes, it is possible to obtain a good display quality. As for the region where the pillar spacer is arranged, in order to maintain the uniformity of the cell gap, a region is selected so that both the array substrate and the opposite substrate can secure a stable flatness, and the spacers are arranged at the same position in each of the pixels (for example, see Japanese Patent No. 3680730 and Japanese Patent Application Publication No. 2004-245952).

[0007] In order to arrange the pillar spacers, regions are selected so that both the array substrate and the opposite substrate can secure a stable flatness. Then, the pillar spacers are respectively arranged at the same positions within the selected regions in the pixels.

[0008] The density of the spacers largely affects the basic characteristics of a liquid crystal display device. Not only is a certain level of density needed for maintaining the uniformity of the cell gap, but also the density of the spacers needs to be increased to achieve high durability against pressure applied to a glass surface. In a display device having a high spacer density, on the other hand, a hollow portion is generated

inside of the display device when pressure is applied to the surface of the display device at a low temperature (hereafter referred to as low-temperature bubble) because the rate of contraction of liquid crystal is faster than that of elastic deformation of the spacers. Therefore, the display quality is significantly deteriorated. In order to solve this problem, a technology has been recently disclosed for increasing durability against local external pressurization while preventing generation of low-temperature bubbles by forming two kinds of spacers having different heights on a substrate (for example, see, Japanese Patent Application Publication No. 2005-189662).

[0009] In addition to the publication described above, various proposals have been made for an arrangement of two kinds of pillar spacers having different heights on a substrate (for example, see, Japanese Patent No. 3338025).

[0010] However, it is still necessary to increase the density of spacers in order to obtain high durability against pressure applied to the glass surface. A certain level of spacer density or above is also required to obtain a uniform cell gap. On the other hand, the spacer density has to be lowered in order to improve the device in terms of the performance against low-temperature bubbles. Therefore, there is a problem that it is extremely difficult to improve the device in terms of the performance against pressure applied to the glass surface and the performance against low-temperature bubbles at the same time.

[0011] Moreover, if a configuration is employed in which spacers having different heights are formed on a substrate in order to solve the problems described above, a new problem of increasing production costs arises due to an increased number of production processes.

SUMMARY OF THE INVENTION

[0012] An object of the present invention regarding a liquid crystal display device is to prevent generation of low-temperature bubbles in a uniform cell gap and to improve the strength against pressure applied to the glass surface without increasing a production cost.

[0013] A liquid crystal display device according to the present invention includes: an array substrate; multiple signal lines, multiple scanning lines, and multiple auxiliary capacitive lines, which are provided on the array substrate; a switching element arranged at each of intersections between the signal lines and the scanning lines; a pixel electrode and an auxiliary capacitive layer which are connected to the switching element; an insulating layer formed on the array substrate; a contact hole, which is formed in the insulating layer, for connecting the switching element to either the corresponding pixel electrode or the corresponding auxiliary capacitive layer; an opposite substrate arranged to face the array substrate; an opposite electrode formed on the opposite substrate; and multiple spacers arranged on the liquid crystal layer side of the array substrate. The multiple spacers include: a first spacer that is arranged on a part of the insulating layer having no contact hole; and a second spacer which is formed inside of the contact hole.

[0014] Another liquid crystal display device according to the present invention includes: an array substrate; multiple signal lines and multiple scanning lines, which are provided on the array substrate; a switching element arranged at each of intersections between the signal lines and the scanning lines; a pixel electrode and an auxiliary capacitive layer which are connected to the switching element; an insulating layer

formed on the array substrate; a contact hole, which is formed in the insulating layer, for connecting each switching element to either a corresponding pixel or a corresponding auxiliary capacitive layer; an opposite substrate arranged to face the array substrate; an opposite electrode formed on the opposite substrate; multiple spacers arranged on the liquid crystal layer side of the array substrate; a light-shielding layer which is formed in a line on the liquid crystal layer side of the opposite substrate, and which includes a wide portion having a larger width than a width of the line; and a colored layer formed on a part of the light-shielding layer. The multiple spacers include: a first spacer which is arranged on a part of the insulating layer having no contact hole so as to face the wide portion of the light-shielding layer; and a second spacer which is arranged on a part of the insulating layer having no contact hole so as not to face the wide portion of the light-shielding layer.

[0015] According to the liquid crystal display device of the present invention, it is possible to further prevent generation of low-temperature bubbles in a uniform cell gap and to further improve the strength against pressure applied to the glass surface without increasing a production cost.

BRIEF DESCRIPTION OF THE DRAWINGS

[0016] FIG. 1 is a plan view illustrating a configuration of an array substrate of a liquid crystal display device according to embodiments of the present invention.

[0017] FIG. 2 is a schematic plan view illustrating a configuration of an opposite substrate of a liquid crystal display device according to a first embodiment.

[0018] FIG. 3 is an enlarged plan view illustrating a part of the opposite substrate of the liquid crystal display device according to the first embodiment.

[0019] FIG. 4 is a cross-sectional view of the liquid crystal display device taken along the line indicated by A-A' in FIG. 3.

[0020] FIG. 5 is a schematic plan view illustrating a density of spacers in a display region in the liquid crystal display device according to the first embodiment.

[0021] FIG. 6 is a schematic plan view illustrating a configuration of an opposite substrate of a liquid crystal display device according to a second embodiment.

[0022] FIG. 7 is an enlarged plan view illustrating a part of the opposite substrate of the liquid crystal display device according to the second embodiment.

[0023] FIG. 8 is a cross-sectional view of the liquid crystal display device taken along the line indicated by B-B' in FIG. 7.

[0024] FIG. 9 is a plan view illustrating a configuration of an array substrate of the liquid crystal display device according to the second embodiment.

DESCRIPTION OF THE EMBODIMENTS

[0025] In the following section, embodiments of the present invention will be described with reference to the drawings.

[0026] The plan view in FIG. 1 schematically illustrates a configuration of an array substrate of a liquid crystal display device according to embodiments of the present invention. A display region 300 indicated by dotted lines is provided on an array substrate 100. In this configuration, an adhesive agent 120 is applied so as to surround the display region 300 seamlessly. Such an application of the adhesive agent 120 allows

no liquid crystal to leak to the outside of the region surrounded by the inner wall of the adhesive agent 120; thus, it is possible to paste the array substrate 100 and a substrate facing the array substrate 100 together by dripping a predetermined amount of liquid crystal in a one-drop fill method.

[0027] In the display region 300, a total of m lines of scanning lines Y1 to Ym (hereafter collectively referred to as Y), and a total of n lines of signal lines X1 to Xm (hereafter collectively referred to as X) are arranged so as to intersect with each other. At each of the intersections, a thin film transistor 140 (hereafter referred to as a pixel TFT) which serves as a switching element, a transparent pixel electrode 131, and an auxiliary capacitor 150 are arranged. A TFT having a semiconductor layer made of amorphous silicon (a-Si) is used as the pixel TFT 140. To be more specific, the pixel TFT 140 includes: a source terminal that is connected to the signal line X; a drain terminal that is connected to the auxiliary capacitor 150 and the pixel electrode 131 in parallel; and a gate terminal that is connected to the scanning line Y. An opposite electrode 173 is arranged facing each of the pixel electrodes 131 across a liquid crystal layer 500. Multiple spacers 600 are arranged for each of the pixel electrodes 131.

[0028] In the region surrounding the display region 300, a scanning line driving circuit 121, a signal line driving circuit 122, and an opposite electrode driving circuit 123 are arranged. The scanning line driving circuit 121 is connected to the scanning lines Y to sequentially drive the scanning lines. The signal line driving circuit 122 is connected to the signal lines X to send image signals. The opposite electrode driving circuit 123 is connected to the auxiliary capacitors 150 and the opposite electrodes 173 to supply a predetermined potential.

[0029] In the following section, a more detailed description will be given of liquid crystal display devices according to first and second embodiments of the present invention.

First Embodiment

[0030] A description will be given of a liquid crystal display device according to a first embodiment of the present invention.

[0031] A configuration of an opposite substrate 200 will be described with reference to FIGS. 2 and 3. As shown in the plan view in FIG. 2, a light-shielding layer 210 is formed in a line in a display region 300. In the peripheral part of the display region 300, the light-shielding layer 210 is formed in a frame shape. A color filter 220 is formed between the light-shielding layers 210. As shown in the plan view in FIG. 3, colored layers (indicated by the dotted lines in the drawing) of the color filter 220 are formed on a part of the light-shielding layer 210. A red colored layer (R), a green colored layer (G), and a blue colored layer (B) are formed in this order repeatedly. In this configuration, a shape 211 having a larger width W2 in some parts than the line width W1 (hereafter referred to as a wide-width portion 211) is formed in the light-shielding layer 210. In this case, the line width W1 is set to, for example, 5 μm , and the shape of the wide-width portion 211 is set to, for example, a square of a side length W2 of 15 μm .

[0032] FIG. 4 illustrates the cross-sectional view of the liquid crystal display device taken along the line indicated by A-A' in FIG. 3. The liquid crystal display device includes: an array substrate 100 and the opposite substrate 200, which are

arranged to face each other; and a liquid crystal layer 500, which is supported by these substrates in the gap therebetween.

[0033] In the array substrate 100, a first insulating layer 102 and a second insulating layer 103 are formed on a glass substrate 101. Although not shown in the drawing, these insulating layers are provided with, for example, an auxiliary capacitive layer and a transparent electrode made of polysilicon, which are connected to the pixel TFT. A spacer 600 having a pillar shape is formed on the first insulating layer 102 and the second insulating layer 103 on the side of the liquid crystal layer 500. In this case, pillar projections serving as the spacer 600 are formed integrally on the substrate so as to have a uniform height by, for example, a photolithographic method. By adopting this process, it is possible to reduce the number of production processes for the production of the array substrate, compared to the case where projections having different heights are formed; thus, the production cost can be reduced. In addition, the spacer 600 is formed, in a flat region of the second insulating layer 103, away from a contact hole 700 formed thereon. A polarizer 104 is arranged, on the glass substrate 101, on the opposite side of the liquid crystal layer 500. On the backside of the array substrate 100, a backlight, which is not shown in the drawing, is arranged for irradiating the display region 300 with light for display.

[0034] In the opposite substrate 200, a polarizer 203 is arranged, on a glass substrate 201, on the opposite side of the liquid crystal layer 500. A light-shielding layer 210 is formed, on the glass substrate 201, on the side of the liquid crystal layer 500. A color filter 220 is formed between the lines of the light-shielding layers 210. In this case, in order to prevent occurrence of light leakage and color mixture due to accuracy in colored layer patterning, the colored layers are formed partly on a linear part of the light-shielding layer 210 and on the wide-width portion 211 of the light-shielding layer. An overcoating layer 202 is formed for flatness to cover the light-shielding layer 210, the wide-width portion 211, and the color filter 220. In addition, although not shown in this drawing, an opposite electrode is formed on the overcoating layer 202.

[0035] Since the amount of colored layers formed on the wide-width portion 211 of the light-shielding layer is larger than that on a linear part of the light-shielding layer 210, unevenness is generated on the opposite substrate. In this configuration, some of the multiple spacers are each arranged on the array substrate 100 as a first spacer 600a so as to face the wide-width portion 211 of the light-shielding layer. In the meantime, other spacers, which do not face the wide-width portion 211 of the light-shielding layer, are each arranged as a second spacer 600b so as to face, for example, a region of the color filter 220, where no light-shielding layer 210 overlaps with a colored layer.

[0036] The first spacer 600a is in contact with the opposite substrate 200, while the second spacer 600b is not in contact with the opposite substrate 200. Accordingly, the effective height of the first spacer 600a is higher by Δh than the effective height of the second spacer 600b. In this case, the difference in the effective height between the first spacer 600a and the second spacer 600b, Δh , is set to be, for example, 0.5 μm .

[0037] By having such a configuration, it is possible with the first spacer 600a to restrain generation of low-temperature bubbles while maintaining uniformity of the cell gap, and possible with the second spacer 600b to control the strength against pressure applied to the substrate surface.

[0038] The plan view in FIG. 5 schematically shows the density (arrangement density) of the spacers in the display region 300 in the liquid crystal display device. In this drawing which illustrates pixels constituting the display region in a matrix, shaded areas indicate pixels where the first spacer 600a is arranged, and white areas indicate pixels where the second spacer 600b is arranged. In this case, the first spacer 600a is arranged in every 12 pixels, while the second spacer 600b is arranged in 11 pixels in every 12 pixels. As a result of such an arrangement, the density of the first spacer 600a is more than 5 times smaller than the density of the second spacer 600b.

[0039] By having the density of the first spacers 600a smaller than the density of the second spacers 600b as described above, it is possible with the first spacer 600a to largely decrease occurrence of low-temperature bubbles while maintaining the minimum density required for obtaining a uniform cell gap. In the meantime, by arranging the second spacer 600b as many as possible to increase the maximum density, it is also possible to largely enhance the strength against pressure applied to the glass surface.

[0040] It should be noted that the cross-sectional area of the first spacer 600a in a direction parallel to the substrate is made approximately twice larger than the cross-sectional area of the second spacer 600b so that the spacers are efficiently arranged. By having such a configuration, it is possible to control the size variation of the first spacers 600a with a high degree of accuracy while maintaining the minimal density by reducing the number of the first spacers 600a arranged, and to maintain a high density of the second spacers 600b by increasing the number of the second spacers 600b arranged.

[0041] Therefore, according to the present embodiment, while a portion having a larger width than the line width on the light-shielding layer 210 is defined as the wide-width portion 211 on the opposite substrate, the first spacer 600a is formed on the array substrate 100 so as to face the wide-width portion 211. The amount of the colored layers of the color filter 220 formed on the wide-width portion 211 of the light-shielding layer is larger than that on a linear part of the light-shielding layer. Accordingly, there is unevenness on the opposite substrate 200, resulting in the effective height of the first spacer 600a higher by Δh . By having this configuration, it is possible with the first spacer 600a to prevent generation of low-temperature bubbles while maintaining uniformity of the cell gap, and it is possible with the second spacer 600b to control strength against pressure applied to the substrate surface. It should be noted that, since spacers having a uniform height are arranged on the array substrate, it is possible to reduce the number of production processes, compared to the case where two kinds of spacers having different heights are arranged.

[0042] According to the present embodiment, by having the density of the first spacers 600a smaller than the density of the second spacers 600b in the display region 300, it is possible with the first spacer 600a to largely decrease the occurrence of low-temperature bubbles while maintaining the minimum density for obtaining a uniform cell gap. In the meantime, by arranging the second spacer 600b as many as possible to increase the maximum density, it is also possible to largely enhance strength against pressure applied to the glass surface.

[0043] According to the present embodiment, by making the cross-sectional area of a first spacer 600a larger than the cross-sectional area of a second spacer 600b in the display region 300, it is possible to control the size variation of the

first spacers **600a** with a high degree of accuracy while maintaining the minimal density by reducing the number of the first spacers **600a** arranged; and to maintain a high density of the second spacer **600b** by increasing the number of the second spacers **600b** arranged.

[0044] It should be noted that the difference in the effective height between the first spacer **600a** and the second spacer **600b**, Δh , is set to be $0.5\ \mu\text{m}$ in the present embodiment; however, the difference in the effective height is not limited to this value. For example, it is possible to obtain the same effect as the present embodiment as long as Δh is in a range from $0.3\ \mu\text{m}$ to $1.0\ \mu\text{m}$. If Δh is to be set to the above range, it is effective to adjust, for example, the area of the wide-width portion **211** of the light-shielding layer **210** and the conditions for application of the overcoating layer **202**. In addition, a value of Δh may be set to be smaller than $0.5\ \mu\text{m}$ (which is the value of Δh in the present embodiment) with small unevenness on the opposite substrate formed by arranging the second spacer **600b** so as to face a linear part of the light-shielding layer **210**.

[0045] The shape of the wide-width portion **211** formed in the light-shielding layer **210** is set to be a square in the present embodiment; however, the shape is not limited to a square. As long as having a larger width than the line width, the shape of the wide-width portion **211** may be, for example, quadrangles, such as rectangle, rhomboid, and circle.

Second Embodiment

[0046] In the following section, a description will be given of a liquid crystal display device according to a second embodiment of the present invention. It should be noted that the same portions as in the first embodiment are denoted by the same reference numerals, and the description thereof is omitted.

[0047] A configuration of an opposite substrate **200** is described with reference to FIGS. 6 and 7. As shown in the plan view in FIG. 6, a light-shielding layer **210** is formed in a liner in a display region **300**. In the peripheral part of the display region **300**, the light-shielding layer **210** is formed in a frame shape. The difference of the present embodiment from the first embodiment is that the light-shielding layer **210** in the present embodiment does not have a shape **211** (wide-width portion **211**) having a width W_2 larger than the line width W_1 . FIG. 7 is an enlarged view of any part of the display region **300** illustrated in FIG. 6. As shown in FIG. 7, the line width of the light-shielding layer **210** is W_1 only.

[0048] FIG. 8 illustrates the cross-sectional view of the liquid crystal display device taken along the line indicated by B-B' in FIG. 7. The liquid crystal display device includes: an array substrate **100** and the opposite substrate **200**, which are arranged to face each other; and a liquid crystal layer **500**, which is supported by the substrates in the gap therebetween. In the present embodiment, the thickness of the liquid crystal layer **500** is $3\ \mu\text{m}$.

[0049] In the array substrate **100**, a first insulating layer **102** and a second insulating layer **103** are formed on a glass substrate **101**. A pixel electrode, which is not shown in the drawing, is formed on these insulating layers. These insulating layers are also provided with contact holes **700** for connecting a drain electrode **59** of a pixel TFT **140** to the pixel electrode. The depth of the contact holes **700** is approximately $2\ \mu\text{m}$.

[0050] A first spacer **600c** is formed on the first insulating layer **102** and the second insulating layer **103** on the side of the liquid crystal layer **500**. To be more specific, the first

spacer **600c** is formed in a flat region having no contact hole **700** provided therein on the second insulating layer **103**. The first spacer **600c** shown in the drawing is arranged on the second insulating layer **103** so as to face the light-shielding layer **210**.

[0051] A second spacer **600d** is formed so as to be buried in the contact hole **700**. The second spacer **600d** shown in the drawing is arranged so as to face a region of the color filter **220**, where no light-shielding layer **210** overlaps with a colored layer.

[0052] It should be noted that the first spacer **600c** and the second spacer **600d** are formed in the same process. By having such a process, it is possible to reduce the number of production processes for the production of the array substrate, compared to the case where projections having different heights are formed in different processes; and therefore to reduce a production cost.

[0053] FIG. 9 is a plan view of the array substrate **100**, and, more particularly, a plan view of the array substrate **100** which is arranged so as to face the part indicated by B-B' in the opposite substrate **200** in FIG. 7. FIG. 9 is also a schematic view of a region of the array substrate **100** including any pixel TFT **140** in the display region **300** described in the FIG. 1 and the adjacent part thereof.

[0054] The pixel TFT **140** includes a source electrode **58**, a gate electrode **56**, and a drain electrode **59**. The drain electrode **59** is connected to the pixel electrode via the contact hole **700**. The drain electrode **59** is also connected to an auxiliary capacitive layer **160** made of polysilicon via a different contact hole **800**. The auxiliary capacitive layer **160** and an auxiliary capacitive line **155** constitute an auxiliary capacitor **150**.

[0055] The first spacer **600c** is arranged at an intersection of a signal line X_{n-1} and the auxiliary capacitive line **155**. Meanwhile, the second spacer **600d** is arranged so as to be buried in the contact hole **700** for connecting the drain electrode **59** to the pixel electrode.

[0056] As for the cross-sectional shapes of the spacers of the present embodiment shown in FIG. 9, the cross-sectional area of the first spacer **600c** is larger than the cross-sectional area of the second spacer **600d**.

[0057] By making the cross-sectional area of the first spacer **600c** larger than the cross-sectional area of the second spacer **600d** in the display region **300**, it is possible to control the size variation of the first spacers **600c** with a high degree of accuracy while maintaining the minimal density thereof by reducing the number of the first spacers **600c** arranged; and to maintain a high density of the second spacer **600d** by increasing the number of the second spacers **600d** arranged.

[0058] It should be noted that cross-sectional areas of the first spacer **600c** and the second spacer **600d** may be the same.

[0059] As described above, with the first spacer **600c** formed on the insulating layer and the second spacer **600d** formed inside of the contact hole **700**, the difference in the effective height between the first spacer **600c** and the second spacer **600d**, Δh , is $0.5\ \mu\text{m}$ due to the depth of the contact hole **700**, in the present embodiment. In other words, in the present embodiment, when spacer materials are evenly applied to coat the substrate in a spacer formation process, the coating material forms a concave portion at a recessed portion formed by the contact hole. Then, by exposing the substrate coated with the coating material to form a pillar spacer, the first pillar spacer **600c** and the second pillar spacer **600d** having different heights are formed by themselves.

[0060] Accordingly, in the present embodiment employing such a configuration, as well as the first embodiment, it is possible with the first spacer **600c** to prevent generation of low-temperature bubbles while maintaining uniformity of the cell gap. With the second spacer **600d**, it is possible to control strength against pressure applied to the substrate surface.

[0061] It is also possible with the first spacer **600c** to largely decrease the occurrence of low-temperature bubbles while maintaining the minimum density required for obtaining a uniform cell gap. In the meantime, by arranging the second spacer **600d** as many as possible to increase the maximum density, it is also possible to largely enhance the strength against pressure applied to the glass surface.

[0062] In the present embodiment, spacers are simply arranged inside of the contact holes in addition to on the insulating layer, which is where spacers are arranged in a conventional method; thus, it is easy to create the difference in the effective height between the spacers, Δh , in a conventional production process. Since the densities of the first spacers and the second spacers can easily be changed, the design freedom is increased.

[0063] It should be noted that, the second spacer **600d** is formed to be buried in the contact hole **700**, which is for connecting the pixel TFT to the pixel electrode in the present embodiment; however, the contact hole where the second spacer **600d** is formed is not limited to the contact hole **700**. The contact hole where the second spacer **600d** is formed to be buried therein may be, for example, a contact hole **800** which is for connecting the pixel TFT to the auxiliary capacitive layer **160**.

[0064] When the shape of the light-shielding layer located on the side of the opposite substrate in the present embodiment is made to be the shapes illustrated in FIGS. **2** and **3** of the first embodiment, it is possible to further adjust the difference in the effective height, Δh .

[0065] Colored layers of the color filter **220** are formed on a part of the light-shielding layer **210**. A red colored layer (R), a green colored layer (G), and a blue colored layer (B) are formed in this order repeatedly. In this configuration, the light-shielding layer **210** includes a shape **211** (hereafter referred to as a wide-width portion **211**) having a larger width W_2 than the line width W_1 in some parts. In this case, the line width W_1 is set to, for example, $5\ \mu\text{m}$, and the shape of the wide-width portion **211** is set to, for example, a square of a side length W_2 of $15\ \mu\text{m}$.

[0066] Accordingly, the amount of colored layers formed on the wide-width portion **211** of the light-shielding layer is larger than that on a linear part of the light-shielding layer **210**; thus, unevenness is generated on the opposite substrate (refer to FIG. **4**). The height of this unevenness is $0.5\ \mu\text{m}$. Thereafter, the first spacer **600c** is arranged on the insulating layer so as to face the wide-width portion **211** of the light-shielding layer.

[0067] As described above, by employing the shape of the light-shielding layer located on the side of the opposite substrate, as shown in FIG. **2**, in the present embodiment, the difference in the effective height, Δh , of $1.0\ \mu\text{m}$ can be achieved by adding the above-described height of the unevenness of $0.5\ \mu\text{m}$ to the original difference in the effective height between the first spacer **600c** and the second spacer **600d**, Δh , of $0.5\ \mu\text{m}$.

[0068] By having the configuration described above, the difference in the effective height, Δh , can be set to be in a range from $0.3\ \mu\text{m}$ to $1.0\ \mu\text{m}$. In this configuration, it is

possible to increase the strength against pressure applied to the substrate surface while restraining generation of low-temperature bubbles, and possible to produce a device having such performance characteristics without an increase in the production cost.

[0069] It should be noted that it is desirable that either the first spacer **600c** or the second spacer **600d** be arranged in each pixel electrode. As for the density of the spacers in the display region **300** in the liquid crystal display device, as shown in FIG. **5**, for example, it is desirable that the density of the first spacers **600c** be smaller than the density of the second spacers **600d**.

[0070] The array substrate and the opposite substrate of the liquid crystal display device are pasted together with an adhesive agent applied therebetween so as to surround the display region seamlessly. Such an application of the adhesive agent allows no liquid crystal to leak to the outside of the region surrounded by the inner wall of the adhesive agent; thus, it is possible to paste these substrates together by applying a uniform pressure on the substrate surface while dripping a pre-determined amount of liquid crystal in a one-drop fill method.

What is claimed is:

1. A liquid crystal display device, comprising:
 - an array substrate;
 - a plurality of signal lines, a plurality of scanning lines and a plurality of auxiliary capacitive lines provided on the array substrate;
 - a switching element arranged at each of intersections between the signal lines and the scanning lines;
 - a pixel electrode and an auxiliary capacitive layer connected to the switching element;
 - an insulating layer formed on the array substrate;
 - a contact hole, formed in the insulating layer, for connecting each of the switching elements to any one of a corresponding pixel electrode and a corresponding auxiliary capacitive layer;
 - an opposite substrate arranged to face the array substrate;
 - an opposite electrode formed on the opposite substrate; and
 - a plurality of spacers arranged on a liquid crystal layer side of the array substrate, wherein the plurality of spacers include: a first spacer arranged on a part of the insulating layer having no contact hole; and a second spacer formed inside of the contact hole.
2. The liquid crystal display device according to claim 1, wherein the second spacer is formed inside of the contact hole that connects the switching element to the pixel electrode.
3. The liquid crystal display device according to claim 1, further comprising:
 - a light-shielding layer which is formed in a line on the liquid crystal layer side on the opposite substrate, and which includes a wide portion having a larger width than the line; and
 - a colored layer formed on a part of the light-shielding layer, wherein the first spacer is arranged so as to face the wide portion of the light-shielding layer.
4. The liquid crystal display device according to claim 1, wherein an arrangement density of the first spacers is smaller than an arrangement density of the second spacers.
5. The liquid crystal display device according to claim 1, wherein a cross-sectional area of the first spacer is larger than a cross-sectional area of the second spacer.
6. The liquid crystal display device according to claim 1, wherein any one of the first spacer and the second spacer is arranged in each of the pixel electrodes.

7. The liquid crystal display device according to claim 1, wherein the array substrate and the opposite substrate are pasted together by an adhesive agent applied between the substrates so as to surround a display region seamlessly.

8. A liquid crystal display device, comprising:

- an array substrate;
- a plurality of signal lines and a plurality of scanning lines provided on the array substrate;
- a switching element arranged at each of intersections between the signal lines and the scanning lines;
- a pixel electrode and an auxiliary capacitive layer connected to the switching element;
- an insulating layer formed on the array substrate;
- a contact hole, formed in the insulating layer, for connecting each switching element to any one of a corresponding pixel electrode and a corresponding auxiliary capacitive layer;
- an opposite substrate arranged to face the array substrate;
- an opposite electrode formed on the opposite substrate;
- a plurality of spacers arranged on the liquid crystal layer side of the array substrate;
- a light-shielding layer which is formed in a line on the liquid crystal layer side of the opposite substrate, and which includes a wide portion having a larger width than a width of the line; and

a colored layer formed on a part of the light-shielding layer, wherein

the plurality of spacers include:

- a first spacer arranged on a part of the insulating layer having no contact hole so as to face the wide portion of the light-shielding layer; and
- a second spacer arranged on a part of the insulating layer having no contact hole so as not to face the wide portion of the light-shielding layer.

9. A liquid crystal display device, comprising:

- an array substrate;
 - a plurality of signal lines and a plurality of scanning lines provided on the array substrate;
 - a switching element arranged at each of intersections between the signal lines and the scanning lines;
 - a pixel electrode and an auxiliary capacitive layer connected to the switching element;
 - an opposite substrate arranged to face the array substrate;
 - an opposite electrode formed on the opposite substrate;
 - a light-shielding layer which is formed in a line on the liquid crystal layer side of the opposite substrate, and which includes a wide portion having a larger width than a width of the line; and
 - a colored layer formed on a part of the light-shielding layer.
10. The liquid crystal display device according to claim 9, wherein the array substrate and the opposite substrate are pasted together by an adhesive agent applied between the substrates so as to surround a display region seamlessly.

* * * * *

专利名称(译)	液晶显示装置		
公开(公告)号	US20080309838A1	公开(公告)日	2008-12-18
申请号	US12/111475	申请日	2008-04-29
[标]申请(专利权)人(译)	东芝松下显示技术股份有限公司		
申请(专利权)人(译)	东芝松下显示技术有限公司.		
当前申请(专利权)人(译)	日本展示CENTRAL INC.		
[标]发明人	FUKUOKA NOBUKO TAKEDA ARIHIRO IIZUKA TETSUYA MORIMOTO HIROKAZU		
发明人	FUKUOKA, NOBUKO TAKEDA, ARIHIRO IIZUKA, TETSUYA MORIMOTO, HIROKAZU		
IPC分类号	G02F1/1339 G02F1/133		
CPC分类号	G02F1/13394 G02F1/136227 G02F2001/13396 G02F2201/50 G02F2203/60		
优先权	2007155039 2007-06-12 JP		
其他公开文献	US7924393		
外部链接	Espacenet USPTO		

摘要(译)

关于液晶显示装置的本发明旨在进一步防止在均匀的单元间隙中产生低温气泡，并进一步提高抵抗施加到玻璃表面的压力的强度，同时节省生产成本。根据本发明的液晶显示装置包括布置在阵列基板的液晶层侧的多个间隔物。多个间隔物包括：第一间隔物，设置在绝缘层的一部分上，其上没有形成接触孔；以及布置在接触孔内部的第二间隔件。接触孔设置在绝缘层上并且将开关元件连接到对应的像素电极或对应的辅助电容层。

