



US 20050280754A1

(19) **United States**

(12) **Patent Application Publication** (10) **Pub. No.: US 2005/0280754 A1**

**Kume et al.** (43) **Pub. Date: Dec. 22, 2005**

(54) **LIQUID CRYSTAL DISPLAY DEVICE AND FABRICATION METHOD FOR THE SAME**

(52) **U.S. Cl.** ..... 349/106; 430/7

(76) **Inventors:** Yasuhiro Kume, Kawachinagano-shi (JP); Noriaki Onishi, Nara-shi (JP); Kazuhiko Tamai, Nabari-shi (JP); Hiroaki Kojima, Kashiba-shi (JP); Nobukazu Nagae, Suwa-shi (JP)

(57) **ABSTRACT**

The liquid crystal display device includes a first substrate, a second substrate opposed to the first substrate, and a vertically aligned liquid crystal layer interposed between the first and second substrates, and has a plurality of pixels each including a first electrode formed on the first substrate, a second electrode formed on the second substrate, and the liquid crystal layer interposed between the first and second electrodes. The first substrate has a shading region in gaps between the plurality of pixels, and a wall structure is placed regularly on the surface of the first substrate facing the liquid crystal layer in the shading region. A color filter layer of the second substrate has at least one hole formed at a predetermined position in each pixel. At least one liquid crystal domain having axisymmetric alignment is formed in the liquid crystal layer when at least a predetermined voltage is applied across the liquid crystal layer, and the center axis of the axisymmetrically aligned liquid crystal domain is formed in or near the hole in the color filter layer.

Correspondence Address:  
**NIXON & VANDERHYE, PC**  
901 NORTH GLEBE ROAD, 11TH FLOOR  
ARLINGTON, VA 22203 (US)

(21) **Appl. No.:** 11/153,920

(22) **Filed:** Jun. 16, 2005

(30) **Foreign Application Priority Data**

Jun. 17, 2004 (JP) ..... 2004-179889

**Publication Classification**

(51) **Int. Cl.<sup>7</sup>** ..... G02F 1/1335

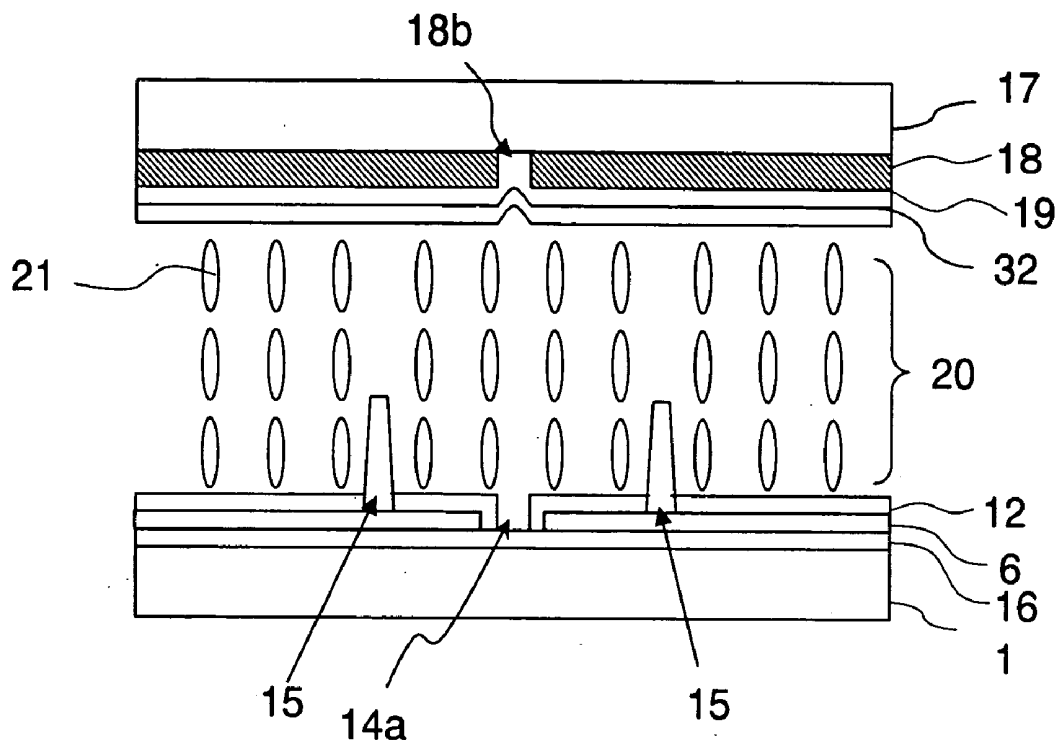

FIG. 1A

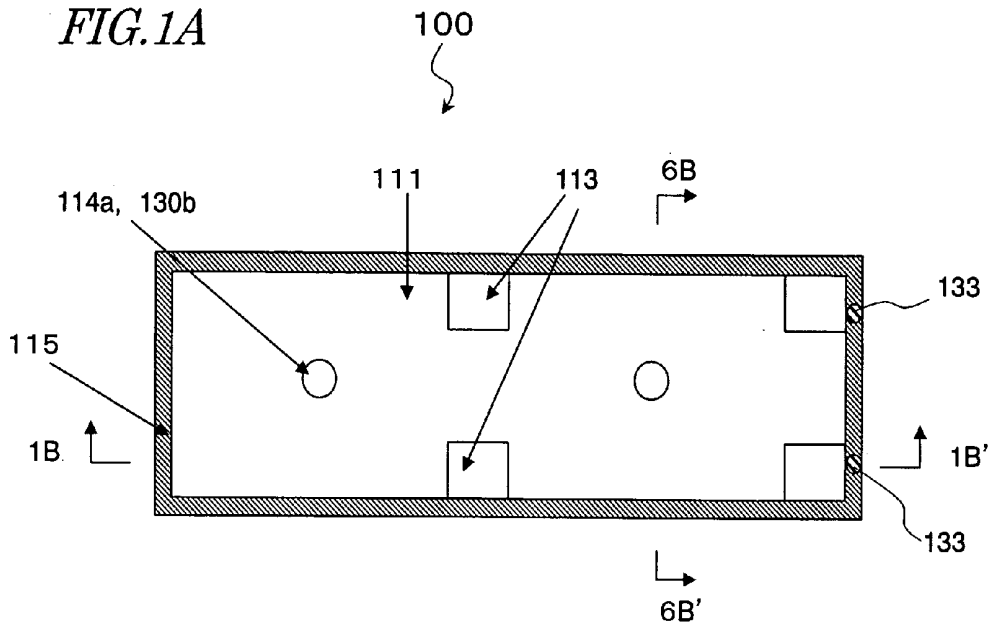

FIG. 1B

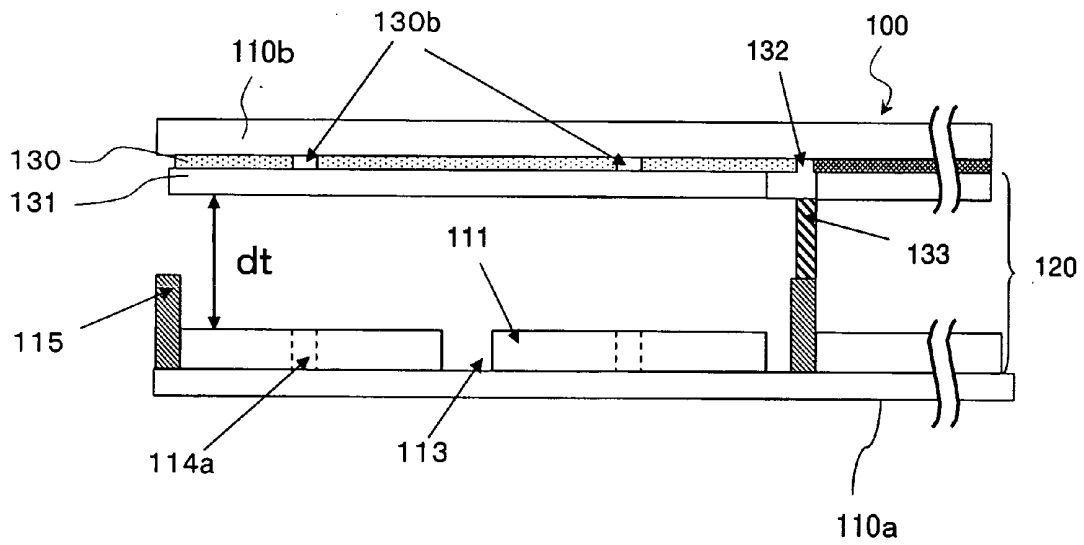

FIG. 2A

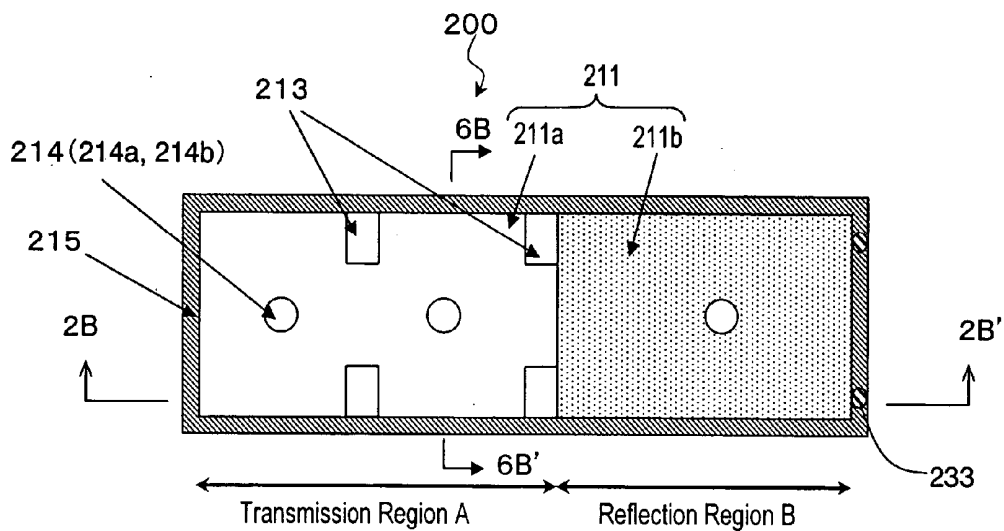

FIG. 2B

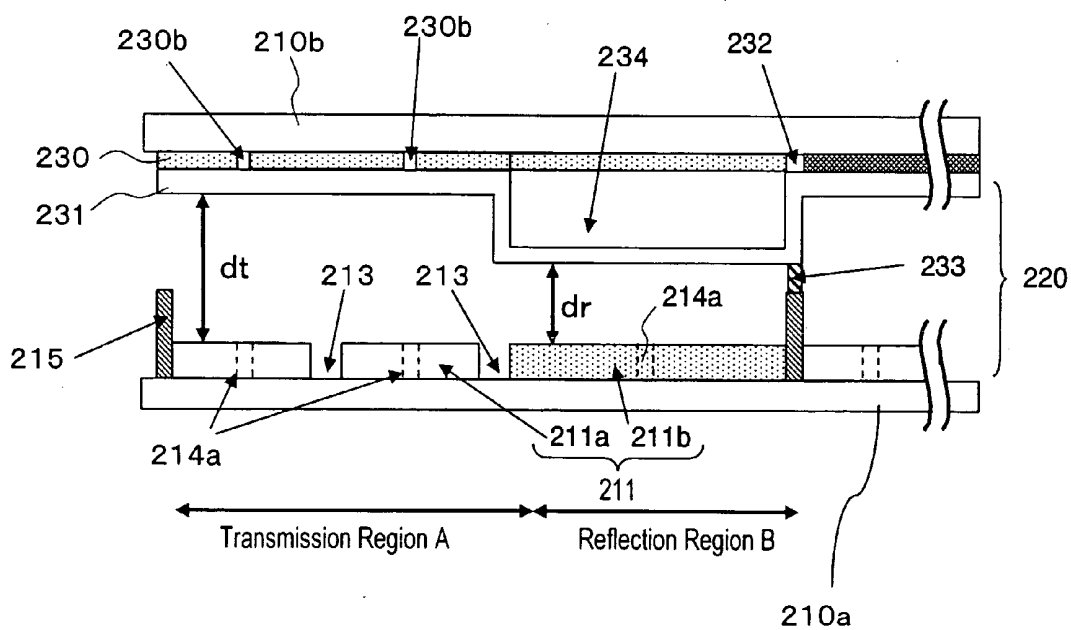

FIG. 3

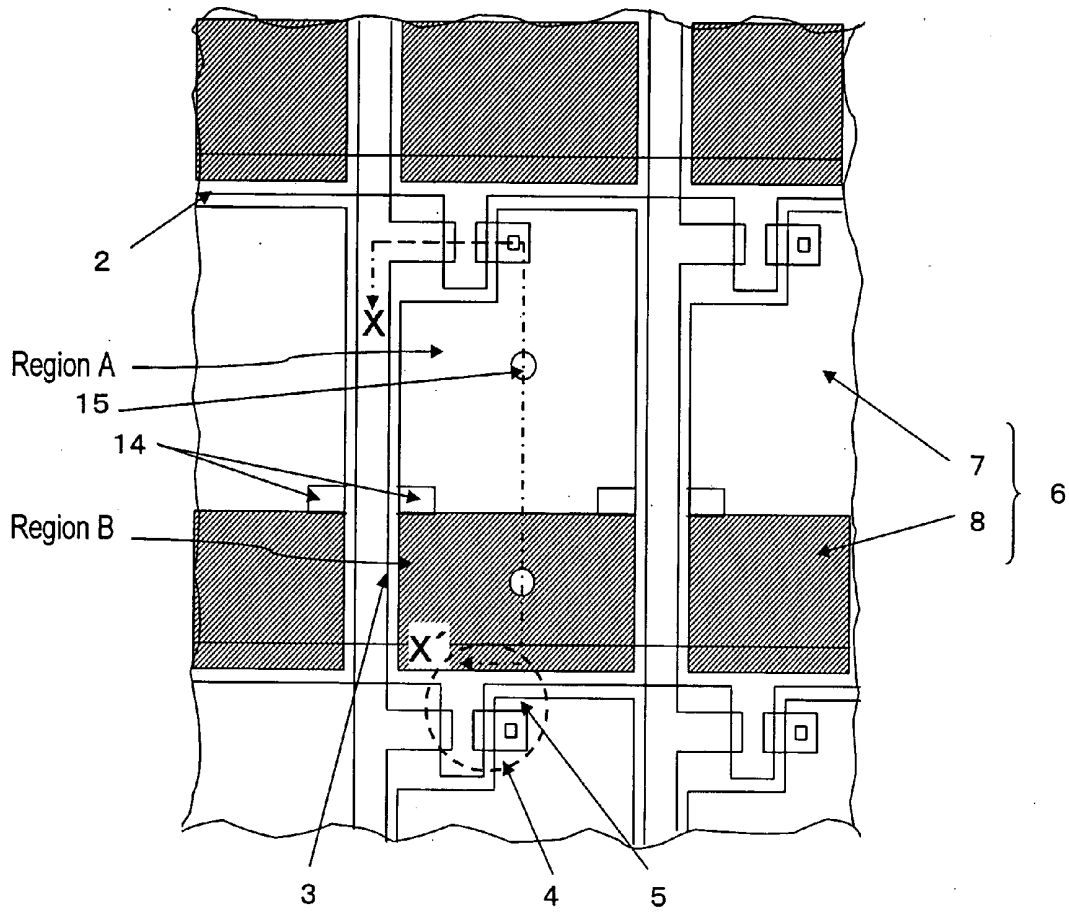

FIG. 4

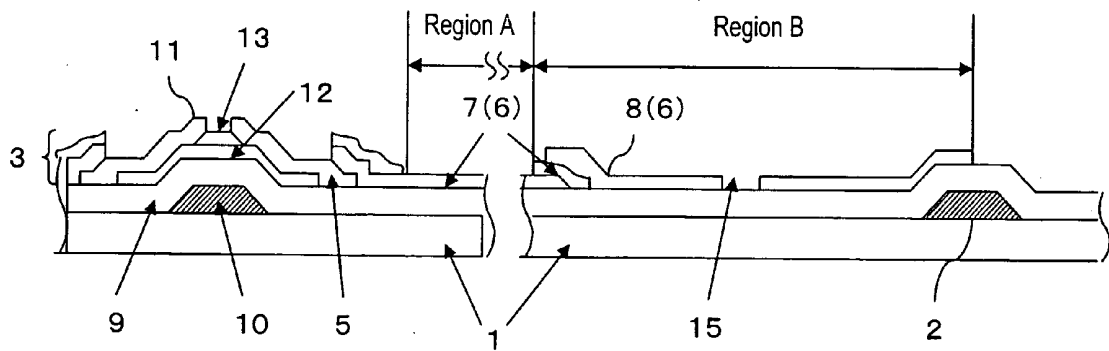

FIG. 5A

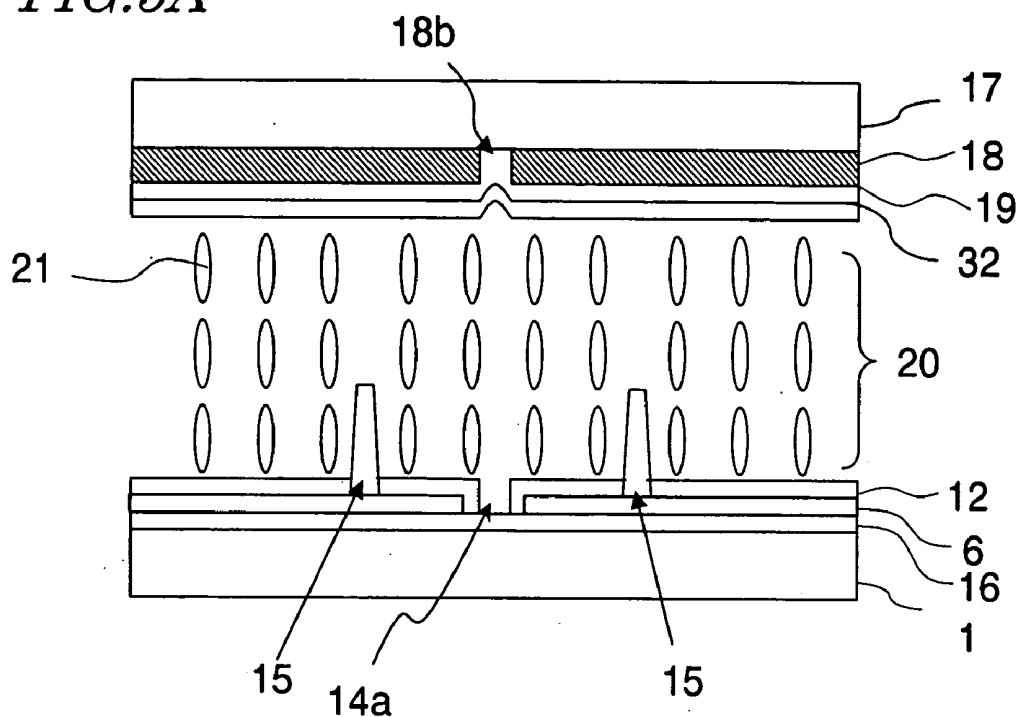

FIG. 5B

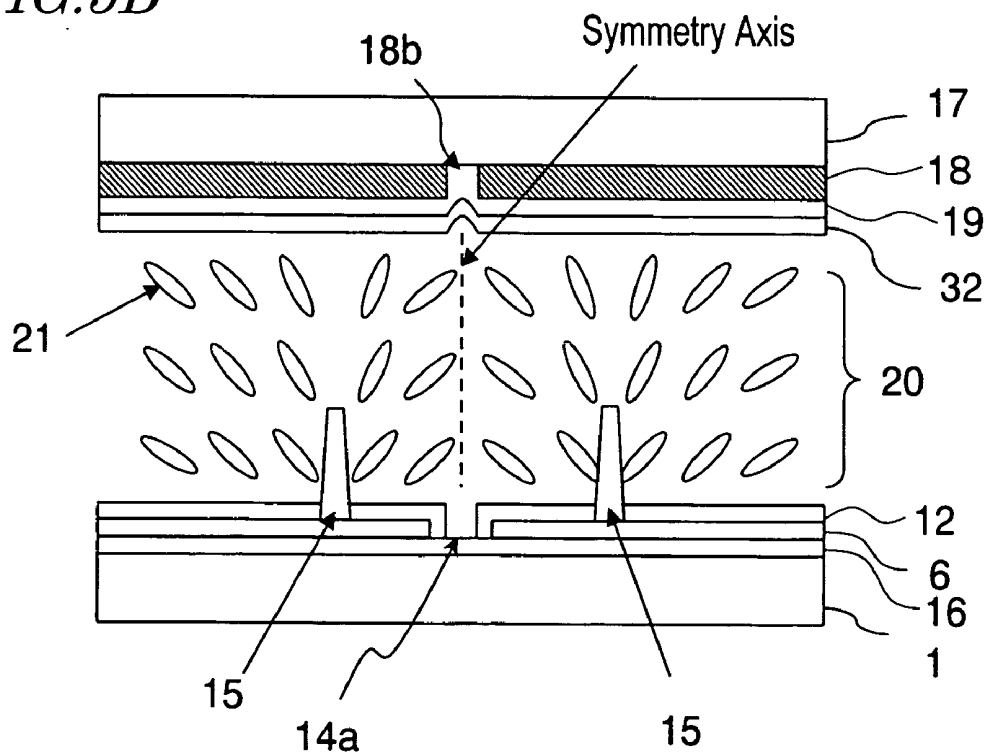

FIG. 6A

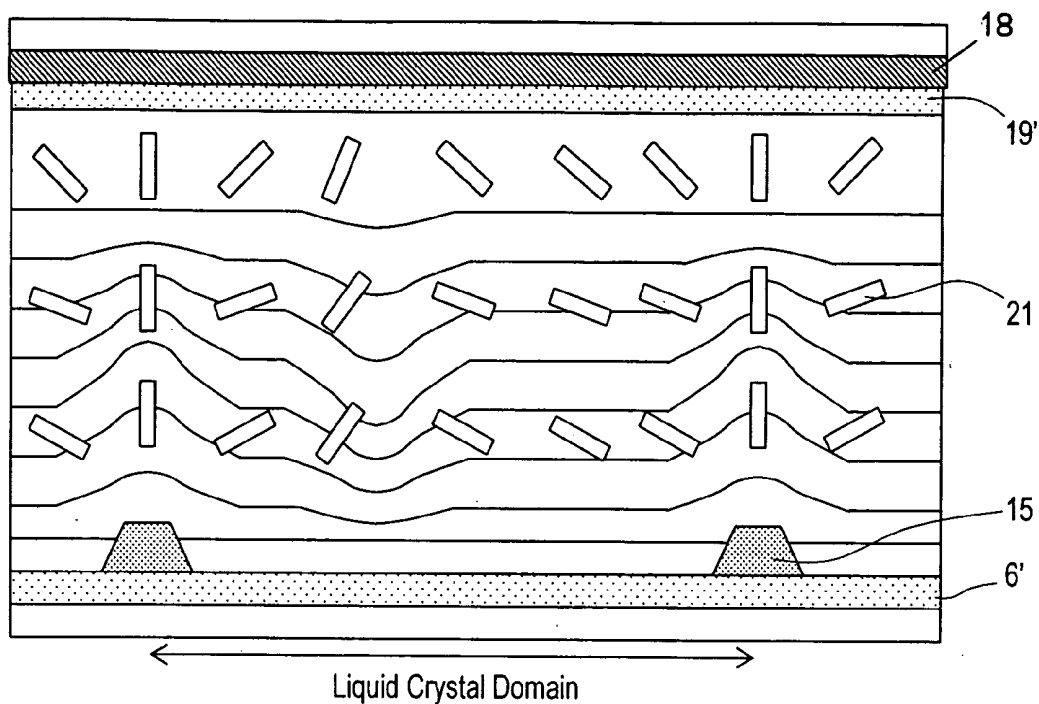

FIG. 6B

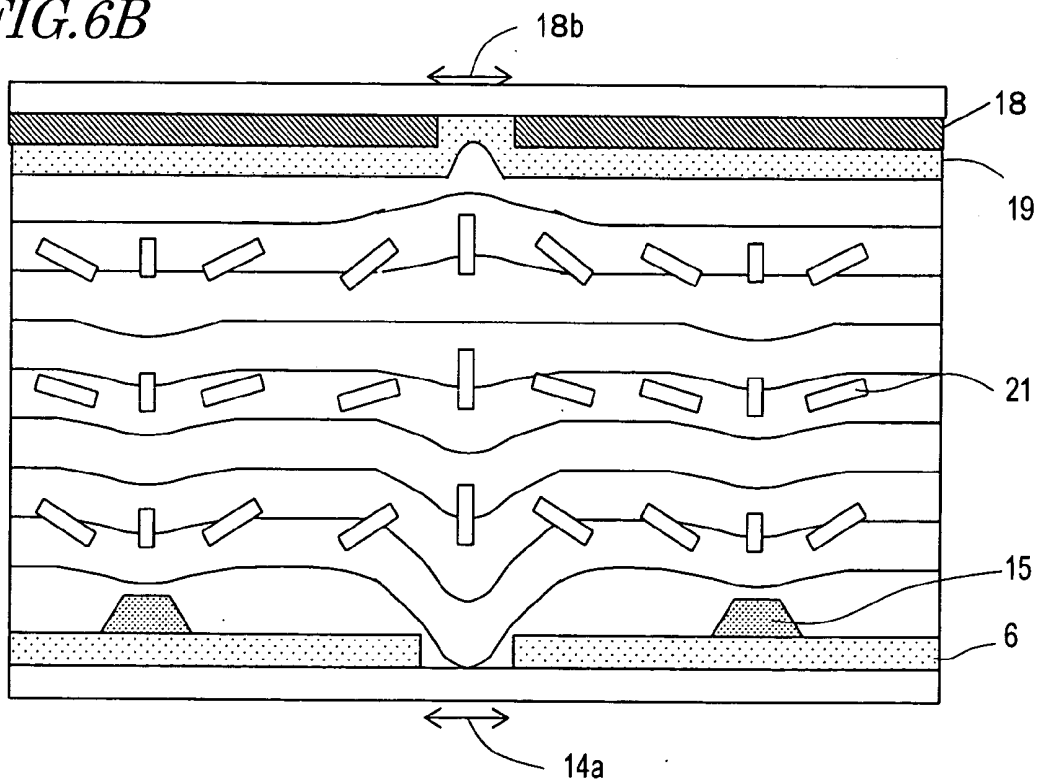

FIG. 7

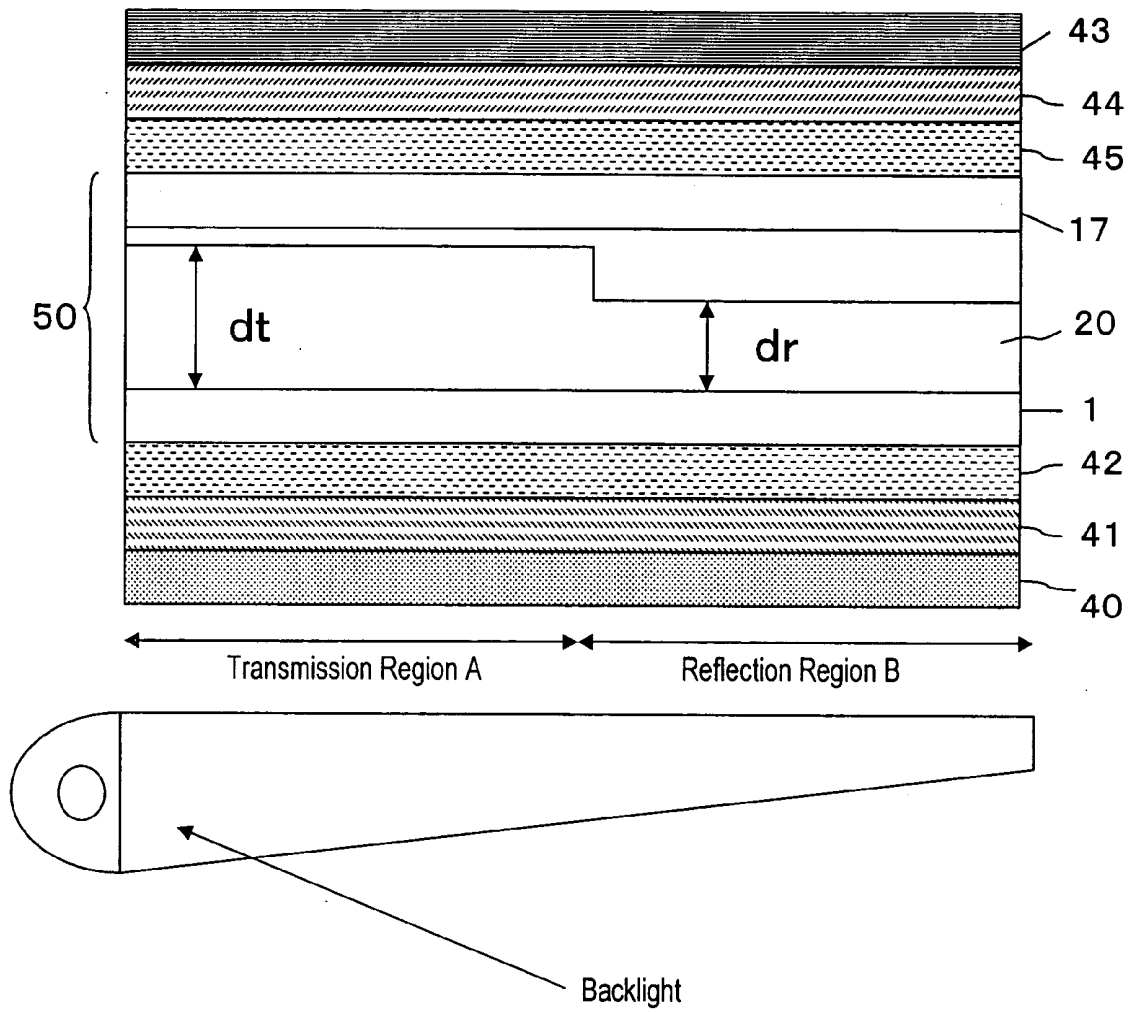

FIG. 8

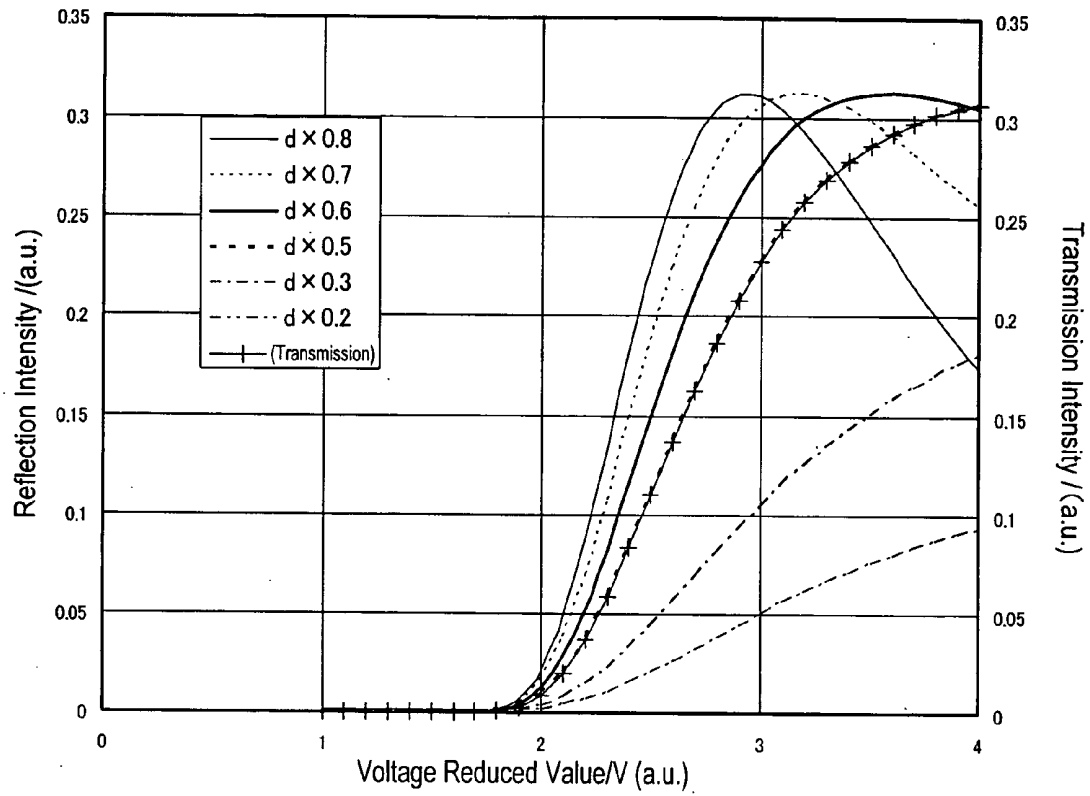
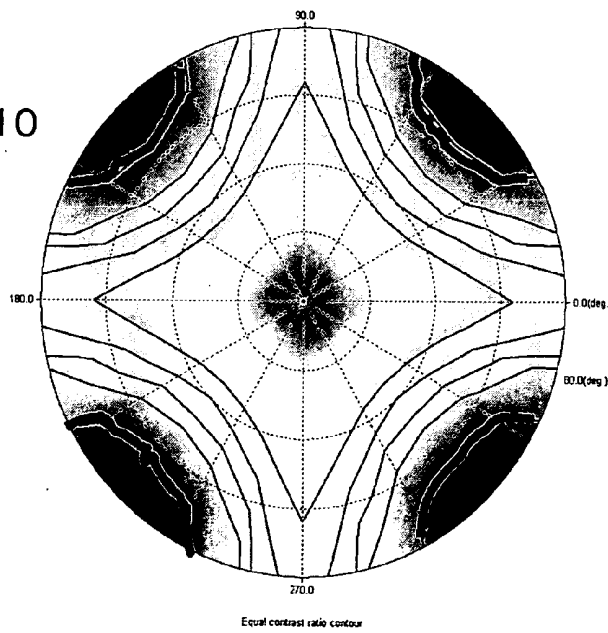

FIG. 9

CR > 10



## LIQUID CRYSTAL DISPLAY DEVICE AND FABRICATION METHOD FOR THE SAME

### BACKGROUND OF THE INVENTION

#### [0001] 1. Field of the Invention

[0002] The present invention relates to a liquid crystal display device and a fabrication method for the same, and more particularly, to a liquid crystal display device suitably used for portable information terminals (for example, PDAs), mobile phones, car-mounted liquid crystal displays, digital cameras, PCs, amusement equipment, TVs and the like.

#### [0003] 2. Description of the Related Art

[0004] The information infrastructure is advancing day to day, and equipment such as mobile phones, PDAs, digital cameras, video cameras and car navigators has penetrated deeply into people's lives. Liquid crystal display (LCD) devices have been adopted in most of such equipment. With increase of the information amount handled with the main bodies of the equipment, LCD devices are requested to display a larger amount of information, and are demanded by the market for higher contrast, a wider viewing angle, higher brightness, multiple colors and higher definition.

[0005] A vertical alignment mode using a vertically aligned liquid crystal layer has increasingly received attention as a display mode enabling high contrast and a wide viewing angle. The vertically aligned liquid crystal layer is generally obtained using a vertical alignment film and a liquid crystal material having negative dielectric anisotropy.

[0006] For example, Japanese Laid-Open Patent Publication No. 6-301036 (Literature 1) discloses an LCD device in which an inclined electric field is generated around an opening formed in a counter electrode that faces a pixel electrode via a liquid crystal layer, so that liquid crystal molecules surrounding liquid crystal molecules existing in the opening, which are in the vertically aligned state, are aligned in inclined directions around the opening as the center, to thereby improve the visual angle characteristics.

[0007] However, in the device described in Literature 1, it is difficult to generate an inclined electric field over the entire region of each pixel. Therefore, each pixel has a region in which liquid crystal molecules delay in response to a voltage, and this causes a problem of occurrence of an afterimage phenomenon.

[0008] Japanese Laid-Open Patent Publication No. 2002-55347 (Literature 2) discloses a technology in which slit electrodes (an opening pattern) are provided in both pixel electrodes and a counter common electrode and, in at least either the pixel electrodes or the common electrode, steps are provided in regions having the slit electrodes to distribute an inclined electric field in four directions uniformly using the opening pattern, to thereby achieve a wide viewing angle.

[0009] Japanese Laid-Open Patent Publication No. 2003-167253 (Literature 3) discloses a technology in which a plurality of projections are provided regularly in each pixel to stabilize the aligned state of liquid crystal domains having radially inclined alignment formed around the projections. This literature also discloses using an inclined electric field generated at openings formed in an electrode, together with

the alignment regulating force of the projections, to regulate the alignment of liquid crystal molecules, and thus improve the display characteristics.

[0010] In recent years, a type of LCD device providing high-quality display both outdoors and indoors has been proposed (see Japanese Patent Gazette No. 2955277 (Literature 4) and U.S. Pat. No. 6,195,140 (Literature 5), for example). In this type of LCD device, called a transmissive LCD device, each pixel has a reflection region in which display is done in the reflection mode and a transmission region in which display is done in the transmission mode.

[0011] The currently available transmissive LCD devices adopt an ECB mode, a TN mode and the like. Literature 3 described above discloses adoption of the vertical alignment mode for, not only a transmissive LCD device, but also a transmissive LCD device. Japanese Laid-Open Patent Publication No. 2002-350853 (Literature 6) discloses a technology in which in a transmissive LCD device having a vertically aligned liquid crystal layer, the alignment (multi-axis alignment) of liquid crystal molecules is controlled with depressions formed on an insulating layer. The insulating layer is provided to make the thickness of the liquid crystal layer in a transmission region twice as large as that in a reflection region. According to this literature, the depressions are in the shape of a regular octagon, for example, and projections or slits (electrode openings) are formed at positions opposed to the depressions via the liquid crystal layer (see FIGS. 4 and 16 of Literature 6, for example).

[0012] The technology disclosed in Literature 3 has the following problems. Projections are provided in each pixel to form a plurality of liquid crystal domains in the pixel (that is, divide the pixel into domains), to thereby strengthen the alignment regulating force on liquid crystal molecules. According to examinations conducted by the inventors of the present invention, however, to obtain sufficient alignment regulating force, it is necessary to form an alignment control structure made of projections regularly placed inside each pixel, and this complicates the fabrication process. The contrast ratio may decrease due to light leakage occurring in the peripheries of the projections in the pixel. If a light-shading portion is provided to prevent decrease in contrast ratio, the effective aperture ratio may possibly decrease.

[0013] In the technology disclosed in Literature 6, it is necessary to provide projections or electrode openings at positions opposed to the depressions formed for control of the multi-axis alignment. This technology therefore has the same problems as those described above.

[0014] In view of the above, an object of the present invention is providing a liquid crystal display device having at least one axisymmetrically aligned domain in each pixel, in which the alignment of liquid crystal molecules is sufficiently fixed/stabilized with a comparatively simple construction.

### SUMMARY OF THE INVENTION

[0015] The liquid crystal display device of the present invention includes a first substrate, a second substrate opposed to the first substrate, and a vertically aligned liquid crystal layer interposed between the first substrate and the second substrate, wherein the liquid crystal display device has a plurality of pixels, each pixel including a first electrode

formed on the first substrate, a second electrode formed on the second substrate, and the liquid crystal layer interposed between the first electrode and the second electrode, the first substrate has a shading region in gaps between the plurality of pixels, and a wall structure is placed regularly on the surface of the first substrate facing the liquid crystal layer in the shading region, the second substrate has a color filter layer on the surface of the second electrode farther from the liquid crystal layer, the color filter layer having at least one hole formed at a predetermined position in each pixel, and at least one liquid crystal domain having axisymmetric alignment is formed in the liquid crystal layer when at least a predetermined voltage is applied across the liquid crystal layer, and the center axis of the axisymmetric alignment of the at least one liquid crystal domain is formed in or near the at least one hole.

[0016] In an embodiment, the at least one hole has a stepped or inclined side face.

[0017] In another embodiment, the first electrode has at least one first opening formed at a predetermined position in the pixel, and one end of the center axis of the axisymmetric alignment of the at least one liquid crystal domain is located in or near the at least one first opening, while the other end is located in or near the at least one hole.

[0018] In yet another embodiment, the at least one first opening and the at least one hole in the color filter layer are placed to at least overlap each other via the liquid crystal layer.

[0019] In yet another embodiment, the first electrode has at least one cut.

[0020] In yet another embodiment, the second electrode has at least one second opening formed at a position corresponding to the at least one hole in the color filter layer.

[0021] In yet another embodiment, a support for defining the thickness of the liquid crystal layer is placed in the shading region located in gaps between the plurality of pixels.

[0022] In yet another embodiment, the first electrode includes a transparent electrode defining a transmission region and a reflective electrode defining a reflection region, and the thickness  $dt$  of the liquid crystal layer in the transmission region and the thickness  $dr$  of the liquid crystal layer in the reflection region satisfy the relationship  $0.3 dt < dr < 0.7 dt$ .

[0023] In yet another embodiment, the first electrode includes a transparent electrode defining a transmission region and a reflective electrode defining a reflection region, the at least one liquid crystal domain includes a liquid crystal domain formed in the transmission region, the at least one hole includes a hole corresponding to the center axis of the liquid crystal domain formed in the transmission region, and the first electrode has a plurality of cuts formed point-symmetrically with respect to the hole.

[0024] In yet another embodiment, a transparent dielectric layer is selectively formed on the second substrate in the reflection region.

[0025] In yet another embodiment, the transparent dielectric layer has a function of scattering light.

[0026] In yet another embodiment, the optical density of the color filter layer in the reflection region is lower than that in the transmission region.

[0027] In yet another embodiment, the liquid crystal display device further includes: a pair of polarizing plates placed to face each other via the first substrate and the second substrate; and at least one biaxial optical anisotropic medium layer placed between the first substrate and one of the pair of polarizing plates and/or between the second substrate and the other polarizing plate.

[0028] In yet another embodiment, the liquid crystal display device further includes: a pair of polarizing plates placed to face each other via the first substrate and the second substrate; and at least one uniaxial optical anisotropic medium layer placed between the first substrate and one of the pair of polarizing plates and/or between the second substrate and the other polarizing plate.

[0029] The fabrication method for a liquid crystal display device of the present invention is a fabrication method for any of the liquid crystal display devices described above, including the step of forming the color filter layer, wherein the step of forming the color filter layer includes the steps of: forming a negative photosensitive resin film on the second substrate; exposing the negative photosensitive resin film to light so that at least one region smaller in exposure amount than the other region is formed at a predetermined position of the negative photosensitive resin film in each pixel; and developing the exposed photosensitive resin film to form the at least one hole at the predetermined position.

[0030] In one embodiment, the step of exposing the negative photosensitive resin comprises the step of forming a region in which the exposure amount changes stepwise or changes continuously, and the at least one hole having a stepped or inclined side face is formed by developing the negative photosensitive resin layer.

[0031] In the liquid crystal display device of the present invention, the directions in which liquid crystal molecules tilt during voltage application (during generation of an electric field) are defined with the slope face effect of the wall structure formed on the surface of the first substrate facing the liquid crystal layer in the shading region, so that an axisymmetrically aligned domain is formed. Also, a hole formed in the color filter layer of the second substrate opposed to the first substrate acts to fix the position of the center axis of the axisymmetric alignment at or near the hole, and this stabilizes the alignment of the axisymmetrically aligned domain.

[0032] Since the wall structure formed on the first substrate is located in the shading region, an axisymmetrically aligned domain can be formed without causing reduction in effective aperture ratio or contrast ratio.

[0033] The hole formed in the color filter layer may be a depression or a through hole. An inclined electric field is formed around the hole in the color filter layer as will be described later, and thus the hole acts to fix/stabilize the center of the axisymmetric alignment. For a hole having a stepped or inclined side face, the side face of the hole also has a function of defining the directions of tilt of liquid crystal molecules (shape effect) because liquid crystal molecules attempt to align themselves vertical to the side face of the hole (precisely, the surface of a vertical alignment film

formed on the side face). The depth of the hole is preferably 20% or more of the thickness of the color filter layer.

[0034] To fix the center axis of the axisymmetric alignment further stably, an opening (first opening) may be formed in the first electrode at the position corresponding to the hole in the color filter layer. To further stabilize the axisymmetric alignment, a cut may be formed at a predetermined position of the first electrode. The directions in which liquid crystal molecules tilt are defined with an inclined electric field generated near the first opening and the cut formed in the first electrode, and thus the function described above is obtained.

[0035] The reduction in effective aperture ratio due to the existence of the opening can be minimized by placing the first opening formed in the first electrode and the hole in the color filter layer of the second substrate so as to at least overlap each other via the liquid crystal layer. Since one center axis is fixed/stabilized with the joint action of the first opening and the hole in the color filter layer, the action of the opening and the hole can be exerted more effectively.

[0036] According to the present invention, the position of the center axis of each axisymmetrically aligned liquid crystal domain is fixed/stabilized. As a result of the fixation of the center axes of the axisymmetrically aligned liquid crystal domains over the entire liquid crystal display panel, the uniformity of the display improves. Accordingly, the roughness of display recognized when grayscale display is viewed in a slanting direction is reduced, and also the response time in grayscale display can be shortened. In addition, as a result of the stabilization of the axisymmetric alignment, the time required to resume normal alignment from an alignment distortion occurring when the liquid crystal display panel is pressed (an afterimage due to pressing) can be shortened.

[0037] By forming an opening in the second electrode at the position corresponding to the hole in the color filter layer, the alignment regulating force with an inclined electric field can be increased to fix the center axis further stably. However, since no patterning is involved in formation of the counter electrode as the second electrode that covers roughly the entire surface of the liquid crystal panel, an additional step is required to form the second opening in the second electrode. On the contrary, patterning is involved in formation of the color filter layer to provide individual color layers. Holes can therefore be formed during this patterning with no additional step required. In other words, according to the present invention, the center axes of axisymmetric alignment can be fixed/stabilized without the necessity of forming second openings in the second electrode, that is, without the necessity of increasing the number of fabrication steps.

[0038] When the present invention is applied to a transmissive LCD device, a transparent dielectric layer may be placed on the second substrate for control of the thickness of the liquid crystal layer. With this construction, an invalid region that does not contribute to display during transmission display can be reduced compared with the conventional transmissive LCD device in which the transmission region and the reflection region are differentiated from each other by forming a step on the first substrate, and thus the brightness in transmission display can be improved. The diffuse reflection plate for improving the brightness in the reflection region may be provided on the first substrate in the

reflection region. Otherwise, a light scattering layer (light diffuse layer) may be formed on the transparent dielectric layer on the second substrate. This can eliminate the necessity of forming projections and depressions on the surface of the reflection electrode.

#### BRIEF DESCRIPTION OF THE DRAWING

[0039] FIGS. 1A and 1B diagrammatically show one pixel of a transmissive LCD device 100 of an embodiment of the present invention, in which FIG. 1A is a plan view and FIG. 1B is a cross-sectional view taken along line 1B-1B' in FIG. 1A.

[0040] FIGS. 2A and 2B diagrammatically show one pixel of a transmissive LCD device 200 of an embodiment of the present invention, in which FIG. 2A is a plan view and FIG. 2B is a cross-sectional view taken along line 2B-2B' in FIG. 2A.

[0041] FIG. 3 is a plan view of an active matrix substrate 210a of the transmissive LCD device 200.

[0042] FIG. 4 is a cross-sectional view of the active matrix substrate 210a of the transmissive LCD device 200.

[0043] FIGS. 5A and 5B are diagrammatic views for demonstrating the operation principle of the LCD devices of the embodiments of the present invention, showing the states during non-voltage application (FIG. 5A) and during voltage application (FIG. 5B).

[0044] FIGS. 6A and 6B are views diagrammatically showing liquid crystal molecules (shown by line segments in the figures) aligned 200 msec after application of a voltage that gives a relative transmittance of 10% to a liquid crystal layer, as well as equipotential lines of an electric field formed in the liquid crystal layer, in which FIG. 6A shows the case of providing no hole or opening and FIG. 6B shows the case of providing a hole in a color filter layer of a counter substrate and an opening in a pixel electrode.

[0045] FIG. 7 is a diagrammatic view showing an example of construction of an LCD device of an embodiment of the present invention.

[0046] FIG. 8 is a graph showing the dependence of the voltage-reflectance (transmittance) of a transmission region and a reflection region on the thickness of the liquid crystal layer in an LCD device of an embodiment of the present invention.

[0047] FIG. 9 is a view showing the visual angle—contrast ratio characteristics of an LCD device of an embodiment of the present invention.

#### DETAILED DESCRIPTION OF THE INVENTION

[0048] Hereinafter, LCD devices of an embodiment of the present invention will be described concretely with reference to the relevant drawings.

[0049] (Transmissive LCD Device)

[0050] A transmissive LCD device 100 of the embodiment of the present invention will be described with reference to FIGS. 1A and 1B. FIGS. 1A and 1B diagrammatically show one pixel of the transmissive LCD device 100, in

which FIG. 1A is a plan view and FIG. 1B is a cross-sectional view taken along line 1B-1B' in FIG. 1A.

[0051] Hereinafter, described will be the case that one pixel is divided into two parts ( $N=2$ ). The number of parts into which one pixel is divided ( $=N$ ) can also be three or more depending on the pixel pitch. In any case, the number of openings ( $=n$ ) each to be positioned roughly in the center of a divided region on a second substrate is preferably the same as the number of divided parts ( $=N$ ). The effective aperture ratio tends to decrease with increase of the number of divided parts ( $=N$ ). Therefore, for an application to a high-definition display panel, the number of divided parts ( $=N$ ) is preferably made small. The present invention is also applicable to the case involving no pixel division (this may be expressed as  $N=1$ ). Each of the divided regions may be called a "sub-pixel". One liquid crystal domain is typically formed in each sub-pixel.

[0052] The LCD device 100 includes a transparent substrate (for example, a glass substrate) 110a, a transparent substrate 110b placed to face the transparent substrate 110a, and a vertically aligned liquid crystal layer 120 interposed between the transparent substrates 110a and 110b. Vertical alignment films (not shown) are formed on the surfaces of the substrates 110a and 110b facing the liquid crystal layer 120. During non-voltage application, therefore, liquid crystal molecules in the liquid crystal layer 120 are aligned roughly vertical to the surfaces of the vertical alignment films. The liquid crystal layer 120 includes a nematic liquid crystal material having negative dielectric anisotropy and also includes a chiral agent as required.

[0053] The LCD device 100 further includes pixel electrodes 111 formed on the transparent substrate 110a and a counter electrode 131 formed on the transparent substrate 110b. Each pixel electrode 111, the counter electrode 131 and the liquid crystal layer 120 interposed between these electrodes define a pixel. In the illustrated example, both the pixel electrodes 111 and the counter electrode 131 are formed of a transparent conductive layer (for example, an ITO layer). Typically, color filters 130 (the entire of the plurality of color filters may also be called a color filter layer 130) provided for the respective pixels, as well as a black matrix (shading layer) 132 formed in the gaps between the adjacent color filters 130, are formed on the surface of the transparent substrate 110b facing the liquid crystal layer 120, and the counter electrode 131 is formed on the color filters 130 and the black matrix 132. Alternatively, the color filters 130 and the black matrix 132 may be formed on the counter electrode 131 (on the surface thereof facing the liquid crystal layer 120).

[0054] In the LCD device 100 shown in FIGS. 1A and 1B, in which the number of divided parts ( $=N$ ) is 2, a wall structure 115 to be described later extends on the transparent substrate 110a in a shading region around the pixel electrodes 111. The color filter layer 130 has holes 130b of the number corresponding to the number of divided parts ( $n=2$  in the illustrated example) at predetermined positions. Each pixel electrode 111 has first openings 114a of the number corresponding to the number of divided parts ( $n=2$  in the illustrated example) at predetermined positions in the pixel. The pixel electrode 111 also has four cuts 113 at predetermined positions. The first openings 114 and/or the cuts 114 in the pixel electrode 111 may be omitted. However, such

openings and cuts can increase the effect of stabilizing axisymmetrically aligned domains and fixing/stabilizing the center axes of the domains. The axisymmetrically aligned domains are formed by providing at least the wall structure 115, and the center axes of the domains can be fixed/stabilized by providing the holes 130b in the color filter layer 130. The holes 130b herein may be depressions or through holes. Note that, although not illustrated in FIG. 1B for simplification, the second (counter) electrode 131 covering the holes 130b in the color filter 130 is actually depressed at the portions corresponding to the holes 130b.

[0055] The first openings 114a and the holes 130b in the color filter layer 130 are positioned to be superposed one on the other spatially via the liquid crystal layer 120. The first openings 114a and the holes 130b have the same size (diameter), and each pair of the first opening 114a the hole 130b coincide with each other when viewed from top as shown in FIG. 1A.

[0056] When a predetermined voltage is applied across the liquid crystal layer, two (number equal to the number of divided parts  $N$ ) liquid crystal domains each having axisymmetric alignment are formed, with the center axes of the axisymmetric alignment thereof being in or near the holes 130b in the color filter layer 130 and the first opening 114a. The holes 130b and the openings 114a act to fix the positions of the center axes of the axisymmetrically aligned domains. With the placement of the hole 130b in the color filter layer 130 and the opening 114a in the pixel electrode 111 to be superposed one on the other via the liquid crystal layer as in the illustrated example, the reduction in effective aperture ratio due to the existence of the hole 130b and the first opening 114a can be minimized. In particular, one center axis can be fixed/stabilized with the action of the hole 130b in the color filter layer 130. The wall structure 115 acts to define the directions in which liquid crystal molecules tilt during voltage application (during generation of an electric field) with its slope face effect. The alignment regulating force of the side slopes of the wall structure 115 acts also during non-voltage application to tilt liquid crystal molecules.

[0057] The cuts 113, provided in the pixel electrode 111 near the boundaries of the axisymmetrically aligned domains, define the directions in which liquid crystal molecules fall with an electric field, and thus act to form the axisymmetrically aligned domains. An inclined electric field is generated around the pairs of openings 114a and the cuts 113 with a voltage applied between the pixel electrode 111 and the counter electrode 131. With this inclined electric field, together with the action of the electric field at the wall faces of the wall structure 115 distorted with the existence of the wall structure 115, the directions of tilt of liquid crystal molecules are defined, resulting in formation of the axisymmetric alignment as described above. In the illustrated example, a total of four cuts 113 are given point-symmetrically with respect to the pair of openings 114a corresponding to the center axis of a liquid crystal domain formed in the pixel (in this case, the right opening as viewed from FIG. 1A) (in this case, the entire pixel is a transmission region).

[0058] By providing the cuts 113 as described above, the directions in which liquid crystal molecules fall during voltage application are defined, allowing formation of two liquid crystal domains. The reason why no cuts are provided

on the left side of the pixel electrode **111** as viewed from **FIG. 1A** is that substantially the same function is obtained from cuts provided on the right side of the adjacent pixel electrode (not shown) located left to the illustrated pixel electrode **111**, and thus cuts, which may decrease the effective aperture ratio of the pixel, are omitted on the left side of the pixel electrode **111**. Also, in the illustrated example, the wall structure **115** to be described later gives the alignment regulating force. Therefore, with no cuts provided on the left side of the pixel electrode **111**, the resultant liquid crystal domain is as stable as a liquid crystal domain having such cuts. In addition, the effect of improving the effective aperture ratio is obtained.

[0059] Although a total of four cuts **113** were formed in the illustrated example, at least one cut between the adjacent liquid crystal domains is sufficient. For example, an elongate cut may be formed in the center of the pixel and the other cuts may be omitted.

[0060] The shape of the holes **130b** in the color filter layer **130**, the first openings **114a** and the like acting to fix the center axes of the axisymmetrically aligned domains is preferably circular as illustrated. The shape is not limited to a circle, but to exert roughly equal alignment regulating force in all directions, the shape is preferably a polygon having four or more sides and also preferably a regular polygon.

[0061] The configuration and placement of the hole **130b** and the first opening **114a** are not limited to the illustrated example in which the hole **130b** and the first opening **114a** having the same size are superposed one on the other. However, by placing the hole **130b** and the first opening **114a** so that the hole **130b** fixes one end of the center axis of the axisymmetric alignment of the liquid crystal domain while the first opening **114a** fixes the other end of the center axis, the fixation of the center axis of the axisymmetric alignment can be further stabilized. Moreover, by placing the hole **130b** and the first opening **114a** to at least overlap each other via the liquid crystal layer, the reduction in effective aperture ratio due to the existence of the first openings **114** will be lessened.

[0062] The shape of the cuts **113** acting to define the directions in which liquid crystal molecules in the axisymmetrically aligned domains fall with the electric field is determined so that roughly equal alignment regulating force is exerted for the adjacent axisymmetrically aligned domains. For example, a square is preferred. The cuts may be omitted.

[0063] The LCD device **100** has a shading region surrounding each of the pixels, and the wall structure **115** is placed on the transparent substrate **110a** in the shading region. The shading region as used herein refers to a region shaded from light due to the presence of TFTs, gate signal lines and source signal lines formed on the peripheries of the pixel electrodes **111** on the transparent substrate **110a**, or the presence of the black matrix formed on the transparent substrate **110b**, for example. Since this region does not contribute to display, the wall structure **115** formed in the shading region is free from adversely affecting the display.

[0064] The illustrated wall structure **115** is a continuous wall surrounding the pixel. Alternatively, the wall structure **115** may be composed of a plurality of separate walls. The

wall structure **115**, which serves to define boundaries of liquid crystal domains located near the outer edges of the pixel, should preferably have a length of some extent. For example, when the wall structure is composed of a plurality of walls, each wall is preferably longer than the gap between the adjacent walls.

[0065] Supports **133** for defining the thickness of the liquid crystal layer **120** (also called the cell gap) are preferably formed in the shading region (in the illustrated example, the region defined by the black matrix **132**) to avoid degradation in display quality due to the supports. Although the supports **133** are formed on the wall structure **115** provided in the shading region in the illustrated example, the supports **133** may be formed on either transparent substrate **110a** or **110b**. In the case of forming the supports **133** on the wall structure **115**, setting is made so that the sum of the height of the wall structure **115** and the height of the supports **133** is equal to the thickness of the liquid crystal layer **120**. If the supports **133** are formed in a region having no wall structure **115**, setting is made so that the height of the supports **133** is equal to the thickness of the liquid crystal layer **120**. The supports **133** can be formed by photolithography using a photosensitive resin, for example.

[0066] In the LCD device **100**, the following is presumed. When a predetermined voltage (voltage equal to or higher than a threshold voltage) is applied between the pixel electrode **111** and the counter electrode **131**, two axisymmetrically aligned liquid crystal domains are formed with their center axes being stabilized in or near the holes **130b** in the color filter layer **130** and the first openings **114a** formed in the pixel electrode **111**. The electric field distorted with the wall faces of the wall structure **115** and the wall face effect of the wall structure **115** mainly define the directions in which liquid crystal molecules in the two adjacent liquid crystal domains fall with an electric field. Also, the inclined electric field generated near the pair of cuts **133** acts to define the directions in which liquid crystal molecules in the two adjacent liquid crystal domains fall with an electric field. Such alignment regulating forces act cooperatively, to stabilize the alignment of the liquid crystal domains.

[0067] As described above, in the LCD device **100** of this embodiment, the positions of the center axes of the axisymmetric alignment of the liquid crystal domains formed for the two sub-pixels are fixed/stabilized. As a result of the fixation of the center axes of the axisymmetrically aligned liquid crystal domains over the entire liquid crystal display panel, the uniformity of the display improves. Also, as a result of the stabilization of the axisymmetric alignment, the response time in grayscale display can be shortened. Moreover, occurrence of an afterimage due to pressing of the liquid crystal display panel can be reduced (the time required to resume from the pressing can be shortened).

[0068] On the surface of the transparent substrate **110a** facing the liquid crystal layer **120**, provided are active elements such as TFTs and circuit elements such as gate signal lines and source signal lines connected to TFTs (all of these elements are not shown). Herein, the transparent substrate **110a**, together with the circuit elements and the pixel electrodes **111**, the wall structure **115**, the supports **133**, the alignment film and the like described above formed on the transparent substrate **110a**, are collectively called an active matrix substrate in some cases. Likewise, the trans-

parent substrate **110b**, together with the color filter layer **130**, the black matrix **132**, the counter electrode **131**, the alignment film and the like formed on the transparent substrate **110b**, are collectively called a counter substrate or a color filter substrate in some cases. The supports **133** may be formed either on the active matrix substrate or on the color filter substrate.

[0069] Although omitted in the above description, the LCD device **100** further includes a pair of polarizing plates placed to face each other via the transparent substrates **110a** and **110b**. The polarizing plates are typically placed so that their transmission axes are orthogonal to each other. The LCD device **100** may further include a biaxial optical anisotropic medium layer and/or a uniaxial optical anisotropic medium layer, as will be described later.

[0070] (Transflective LCD Device)

[0071] Next, a transflective LCD device **200** of an embodiment of the present invention will be described with reference to **FIGS. 2A and 2B**.

[0072] **FIGS. 2A and 2B** diagrammatically show one pixel of the transflective LCD device **200** of the embodiment of the present invention, in which **FIG. 2A** is a plan view and **FIG. 2B** is a cross-sectional view taken along line **2B-2B'** in **FIG. 2A**.

[0073] Hereinafter, described will be a case that one pixel is divided into three parts ( $N=3$ ; two for the transmission region and one for the reflection region). The number of parts into which one pixel is divided ( $=N$ ) can be at least two (at least one for the transmission region and at least one for the reflection region) determined depending on the pixel pitch. The number of holes ( $=n$ ) in the color filter layer each to be positioned roughly in the center of a divided region (region in which an axisymmetrically aligned domain is formed) on the counter substrate (second substrate) is preferably the same as the number of divided parts ( $=N$ ). Note however that if a transparent dielectric layer is selectively formed on the surface of the counter substrate facing the liquid crystal layer in the reflection region, to be described later, no hole may be formed in the color filter in the reflection region. The effective aperture ratio tends to decrease with increase of the number of divided parts ( $=N$ ). Therefore, for an application to a high-definition display panel, the number of divided parts ( $=N$ ) is preferably made small. However, by making holes in the color filter layer to provide color filter-free regions in each pixel regularly, absorption of light with the color filter layer will be lessened, and thus the transmittance will substantially increase.

[0074] The LCD device **200** includes a transparent substrate (for example, a glass substrate) **210a**, a transparent substrate **210b** placed to face the transparent substrate **210a**, and a vertically aligned liquid crystal layer **220** interposed between the transparent substrates **210a** and **210b**. Vertical alignment films (not shown) are formed on the surfaces of the substrates **210a** and **210b** facing the liquid crystal layer **220**. During non-voltage application, therefore, liquid crystal molecules in the liquid crystal layer **220** are aligned roughly vertical to the surfaces of the vertical alignment films. The liquid crystal layer **220** includes a nematic liquid crystal material having negative dielectric anisotropy and also includes a chiral agent as required.

[0075] The LCD device **200** further includes pixel electrodes **211** formed on the transparent substrate **210a** and a

counter electrode **231** formed on the transparent substrate **210b**. Each pixel electrode **211**, the counter electrode **231** and the liquid crystal layer **220** interposed between these electrodes define a pixel. Circuit elements such as TFTs are formed on the transparent substrate **210a** as will be described later. Herein, the transparent substrate **210a** and the components formed thereon are collectively called an active matrix substrate **210a** in some cases.

[0076] Typically, color filters **230** (the entire of the plurality of color filters may also be called a color filter layer **230**) provided for the respective pixels, as well as a black matrix (shading layer) **232** provided in the gaps between the adjacent color filters **230**, are formed on the surface of the transparent substrate **210b** facing the liquid crystal layer **220**, and the counter electrode **231** is formed on the color filters **230** and the black matrix **232**. Alternatively, the color filters **230** and the black matrix **232** may be formed on the counter electrode **231** (on the surface thereof facing the liquid crystal layer **220**). Herein, the transparent substrate **210b** and the components formed thereon are collectively called a counter substrate (color filter substrate) **210b** in some cases.

[0077] Each pixel electrode **211** includes a transparent electrode **211a** formed of a transparent conductive layer (for example, an ITO layer) and a reflective electrode **211b** formed of a metal layer (for example, an Al layer, an Al-including alloy layer, and a multilayer film including any of these layers). Having such a pixel electrode, each pixel includes a transmission region A defined by the transparent electrode **211a** and a reflection region B defined by the reflective electrode **211b**, to provide display in the transmission mode and display in the reflection mode, respectively.

[0078] In the LCD device **200** shown in **FIGS. 2A and 2B**, in which the number of divided parts ( $=N$ ) is 3 (two for the transmission region and one for the reflection region), holes **230b** of the number corresponding to the number of divided parts ( $n=2$  in the illustrated example) are formed in the color filter layer **230** of the counter color filter substrate **210b** at positions roughly in the centers of liquid crystal domains corresponding to the divided regions in the transmission region A, while no hole is formed in the divided region in the reflection region B. The reasons for this are as follows. With a transparent dielectric layer **234** selectively formed on the surface of the counter substrate facing the liquid crystal layer in the reflection region B, the alignment regulation effect of the hole **230b** will hardly be exerted. Also, since the display quality (for example, the contrast ratio) is low in the reflection mode compared with that in the transmission mode, lack of alignment uniformity in the reflection region B, if any, will not affect the display quality. No problem will therefore arise by omitting the hole for fixing/stabilizing the center axis. Naturally, a hole may be formed in the transparent dielectric layer **234**, in place of forming a hole in the color filter layer **230**, to fix/stabilize the center axis of the axisymmetric alignment.

[0079] On the active matrix substrate **210a**, a wall structure **215** to be described later extends in a shading region around each pixel electrode **211**. The pixel electrode **211** has first openings **214a** of the number corresponding to the number of divided parts ( $n=3$  in the illustrated example) at predetermined positions in the pixel. That is, the pixel electrode **211** has two first openings **214a** in the transmission

region A and one first opening **214a** in the reflection region B. The pixel electrode **211** also has four cuts **213** at predetermined positions.

[0080] The first openings **214a** and/or the cuts **213** in the pixel electrode **211** may be omitted. However, such openings and cuts can increase the effect of stabilizing axisymmetrically aligned domains and fixing/stabilizing the center axes of the domains. The axisymmetrically aligned domains are formed by providing at least the wall structure **215**, and the center axes of the domains can be fixed/stabilized by providing the holes **230b** in the color filter layer **230**. The holes **230b** may be depressions or through holes.

[0081] When a predetermined voltage is applied across the liquid crystal layer, three (number equal to the number of divided parts N) liquid crystal domains each having axisymmetric alignment are formed, with the center axes of the axisymmetric alignment of the liquid crystal domains being positioned in or near the holes **230b** in the color filter layer and/or the first openings **214a**. When each hole **230b** in the color filter layer **230** and each first opening **214a** are placed to be superposed one on the other in the transmission region A as in the illustrated example, the reduction in effective aperture ratio due to the existence of the first opening **214a** can be minimized. In the reflection region B, the first opening **214a** in the pixel electrode **211** acts to fix/stabilize the center axis of the axisymmetric alignment.

[0082] The wall structure **215** formed on the first substrate acts to define the directions in which liquid crystal molecules tilt during voltage application (during generation of an electric field) with its slope face effect. Moreover, the cuts **213**, which are formed as required near a boundary between axisymmetrically aligned domains, act to define the directions in which liquid crystal molecules tilt with an electric field, to form the axisymmetrically aligned domains. An inclined electric field is generated around the cuts **213** with the application of a voltage between the pixel electrode **211** and the counter electrode **213**. With this inclined electric field, acting together with an electric field at the wall faces distorted with the wall structure **215**, the directions of tilt of liquid crystal molecules are defined, resulting in formation of the axisymmetric alignment as described above.

[0083] In the illustrated example, a total of four cuts **213** are given point-symmetrically with respect to the opening **214a** corresponding to the center axis of a liquid crystal domain formed in the transmission region A of the pixel (in this case, the right opening in the transmission region A as viewed from FIG. 2A). With these cuts **213**, the directions in which liquid crystal molecules fall during voltage application are defined, resulting in formation of three liquid crystal domains. The placement and preferred shapes of the wall structure **215**, the openings **214** and the cuts **213** are the same as those described above in relation to the transmissive LCD device **100**.

[0084] In the example illustrated in FIGS. 2A and 2B, the transmission region A has two liquid crystal domains and the reflection region B has one liquid crystal domain. However, the arrangement is not limited to this. Each liquid crystal domain is preferably roughly square in shape from the standpoint of the viewing angle characteristics and the stability of alignment.

[0085] The LCD device **200** has a shading region around each pixel, and the wall structure **215** extends on the

transparent substrate **210a** in the shading region. Since the shading region does not contribute to display, the wall structure **215** formed in the shading region is free from adversely affecting the display. The wall structure **215** shown in the illustrated example is a continuous wall surrounding the pixel. Alternatively, the wall structure **215** may be composed of a plurality of separate walls. The wall structure **215**, which serves to define boundaries of liquid crystal domains located near the outer edges of the pixel, should preferably have a length of some extent.

[0086] Supports **233** for defining the thickness of the liquid crystal layer **220** (also called the cell gap) should preferably be formed in the shading region (in the illustrated example, the region defined by the black matrix **232**) to avoid degradation of the display quality due to the supports. Although the supports **233** are formed on the wall structure **215** provided in the shading region in the illustrated example, the supports **233** may be formed on either transparent substrate **210a** or **210b**. In the case of forming the supports **233** on the wall structure **215**, setting is made so that the sum of the height of the wall structure **215** and the height of the supports **233** is equal to the thickness of the liquid crystal layer **220**. If the supports **233** are formed in a region having no wall structure **215**, setting is made so that the height of the supports **233** is equal to the thickness of the liquid crystal layer **220**.

[0087] In the LCD device **200**, when a predetermined voltage (voltage equal to or higher than a threshold voltage) is applied between the pixel electrode **211** and the counter electrode **231**, two axisymmetrically aligned domains are formed in the transmission region A, and one axisymmetrically aligned domain is formed in the reflection region B. The electric field distorted with the wall faces of the wall structure **215** and the wall face effect of the wall structure **215** mainly define the directions in which liquid crystal molecules in the three adjacent liquid crystal domains (two in the transmission region and one in the reflection region) fall with an electric field. Also, the inclined electric field generated near the four cuts **233** acts to define the directions in which liquid crystal molecules in the three adjacent liquid crystal domains fall with the electric field. Such alignment regulating forces act cooperatively, to stabilize the axisymmetric alignment of the liquid crystal domains. Moreover, the center axes of the two axisymmetrically aligned liquid crystal domains formed in the transmission region A are fixed in or near the holes **230b** in the color filter layer **230** and the first openings **214a** formed roughly in the centers of the divided regions in the pixel, and stabilized. The center axis of the one axisymmetrically aligned liquid crystal domain formed in the reflection region B is fixed/stabilized with the first opening **214a** formed roughly in the center of the reflection region B.

[0088] A preferred construction specific to the transmissive LCD device **200** permitting both the transmission-mode display and the reflection-mode display will be described.

[0089] While light used for display passes through the liquid crystal layer **220** once in the transmission-mode display, it passes through the liquid crystal layer **220** twice in the reflection-mode display. Accordingly, as diagrammatically shown in FIG. 2B, the thickness  $dt$  of the liquid crystal layer **220** in the transmission region A is preferably set roughly double the thickness  $dr$  of the liquid crystal layer

**220** in the reflection region B. By setting in this way, the retardation given to the light by the liquid crystal layer **220** can be roughly the same in both display modes. Most preferably,  $dr=0.5 dt$  should be satisfied, but good display is secured in both display modes as long as  $0.3 dt < dr < 0.7 dt$  is satisfied. Naturally,  $dt=dr$  may be satisfied depending on the use.

[0090] In the LCD device **200**, a transparent dielectric layer **234** is provided on the glass substrate **210b** only in the reflection region B to make the thickness of the liquid crystal layer **220** in the reflection region B smaller than that in the transmission region A. This construction eliminates the necessity of providing a step by forming an insulating film and the like under the reflective electrode **211b**, and thus has an advantage of simplifying the fabrication of the active matrix substrate **210a**. If the reflective electrode **211b** is formed on such an insulating film provided to give a step for adjusting the thickness of the liquid crystal layer **220**, light used for transmission display will be shaded with the reflective electrode covering a slope (tapered face) of the insulating film, or light reflected from the reflective electrode formed on a slope of the insulating film will repeat internal reflection, failing to be effectively used even for reflection display. By adopting the construction described above, occurrence of such problems is prevented, and thus the light use efficiency can be improved.

[0091] If the transparent dielectric layer **234** is provided with a function of scattering light (diffuse reflection function), white display close to good paper white can be realized without the necessity of providing the reflective electrode **211b** with the diffuse reflection function. Such white display close to paper white can also be realized by making the surface of the reflective electrode **211b** uneven, and in this case, no light scattering function is necessary for the transparent dielectric layer **234**. However, the uneven surface may fail to stabilize the position of the center axis of the axisymmetric alignment depending on the shape of the uneven surface. On the contrary, by combining the transparent dielectric layer **234** having the light scattering function and the reflective electrode **211b** having a flat surface, the position of the center axis can be stabilized with the opening **214a** formed in the reflective electrode **211b** more reliably. Naturally, if the opening **214b** is provided in the counter electrode **231** in the reflection region B, the center axis of the axisymmetric alignment will be further stabilized. Note that in the case of making the surface of the reflective electrode **211b** uneven to provide the reflective electrode **211b** with the diffuse reflection function, the uneven shape is preferably a continuous wave shape to prevent occurrence of an interference color, and such a shape is preferably set to allow stabilization of the center axis of the axisymmetric alignment.

[0092] While light used for display passes through the color filter layer **230** once in the transmission mode, it passes through the color filter layer **230** twice in the reflection mode. Accordingly, if the color filter layer **230** has the same optical density both in the transmission region A and the reflection region B, the color purity and/or the luminance may decrease in the reflection mode. To suppress occurrence of this problem, the optical density of the color filter layer in the reflection region is preferably made lower than that in the transmission region. The optical density as used herein is a characteristic value characterizing the color filter layer.

For example, the optical density can be reduced by reducing the thickness of the color filter layer. Otherwise, the optical density can be reduced by reducing the density of a pigment added, for example, while keeping the thickness of the color filter layer unchanged. Forming a color filter layer different in color layer between the transmission region A and the reflection region B in the way described above is greatly effective for improvement of the display color reproducibility.

[0093] Next, referring to **FIGS. 3 and 4**, an example of the structure of an active matrix substrate suitably used for the transfective LCD device will be described. **FIG. 3** is a partial enlarged view of the active matrix substrate, and **FIG. 4** is a cross-sectional view taken along line X-X' in **FIG. 3**. The active matrix substrate shown in **FIGS. 3 and 4** can be the same in construction as the active matrix substrate **211a** shown in **FIGS. 2A and 2B**, except that one liquid crystal domain is formed in the transmission region A (that is, the numbers of the openings **214** and the cuts **213** are reduced).

[0094] The active matrix substrate shown in **FIGS. 3 and 4** has a transparent substrate **1** made of a glass substrate, for example. Gate signal lines **2** and source signal lines **3** run on the transparent substrate **1** to cross each other at right angles. TFTs **4** are formed near the crossings of these signal lines **2** and **3**. Drain electrodes **5** of the TFTs **4** are connected to corresponding pixel electrodes **6**.

[0095] Each of the pixel electrode **6** includes a transparent electrode **7** made of a transparent conductive layer such as an ITO layer and a reflective electrode **8** made of Al and the like. The transparent electrode **7** defines a transmission region A, and the reflective electrode **8** defines a reflection region B. Cuts **14** are formed at predetermined positions of the pixel electrode **6** for controlling the alignment of the axisymmetrically aligned domains as described above. Also, a wall structure (not shown) is formed in a non-display region outside each pixel (shading region) where signal lines extend, for defining the aligned state of the axisymmetrically aligned domains.

[0096] The pixel electrode **6** overlaps the gate signal line for the next row via a gate insulating film **9**, forming a storage capacitance. The TFT **4** has a multilayer structure including the gate insulating film **9**, a semiconductor layer **12**, a channel protection layer **13** and an n<sup>+</sup>-Si layer **11** (source/drain electrodes) formed in this order on a gate electrode **10** branched from the gate signal line **2**.

[0097] The illustrated TFT is of a bottom gate type. The TFT is not limited to this type, but a top gate type TFT can also be used.

[0098] As described above, in the LCD **200** having the construction shown in **FIGS. 2A and 2B**, the center axes of the axisymmetrically aligned liquid crystal domains formed in the transmission region A are fixed and stabilized with the holes **230b** in the color filter layer **230** and the first openings **214a** in the pixel electrode **211**. The center axis of the axisymmetrically aligned liquid crystal domain formed in the reflection region B is fixed and stabilized with the first opening **214a** in the pixel electrode **211**. As a result of the fixation of the center axes of the axisymmetrically aligned liquid crystal domains over the entire liquid crystal display panel, the uniformity of the display improves, as in the LCD

device **100**. Also, as a result of the stabilization of the axisymmetric alignment, the response time in grayscale display can be shortened. Moreover, occurrence of an after-image due to pressing of the liquid crystal display panel can be reduced (the time required to resume from the pressing can be shortened).

[0099] Furthermore, with the placement of the transparent dielectric layer **234** and/or the color filter **230** in the manner described above, the display brightness and color purity in both the transmission mode and the reflection mode can be improved.

[0100] (Operation Principle)

[0101] The reason why the LCD device having a vertically aligned liquid crystal layer of the embodiment of the present invention has excellent wide viewing angle characteristics will be described with reference to **FIGS. 5A and 5B**.

[0102] **FIGS. 5A and 5B** are views for demonstrating how the alignment regulating forces of a wall structure **15** and an opening **14a** formed on the active matrix substrate and a hole **18b** formed in a color filter layer **18** of the color filter substrate act, in which the aligned states of liquid crystal molecules during non-voltage application (**FIG. 5A**) and during voltage application (**FIG. 5B**) are diagrammatically shown. The state shown in **FIG. 5B** is for display of a grayscale level.

[0103] The LCD device shown in **FIGS. 5A and 5B** includes an insulating film **16**, a pixel electrode **6** having the opening **14a** at a predetermined position, the wall structure **15** and an alignment film **12** formed in this order on a transparent substrate **1**. The LCD device also includes the color filter layer **18** having the hole **18b** (through hole in the illustrated example) at a predetermined position, a counter electrode **19** and an alignment film **32** formed in this order on another transparent substrate **17**. A liquid crystal layer **20** interposed between the two substrates includes liquid crystal molecules **21** having negative dielectric anisotropy.

[0104] As shown in **FIG. 5A**, during non-voltage application, the liquid crystal molecules **21** are aligned roughly vertical to the substrate surface with the alignment regulating force of the vertical alignment films **12** and **32**.

[0105] As shown in **FIG. 5B**, during voltage application, the liquid crystal molecules **21** having negative dielectric anisotropy attempt to make their major axes vertical to electric lines of force, and this causes the directions in which the liquid crystal molecules **21** fall to be defined with an inclined electric field generated around the opening **14a** and cuts and distortion in electric field occurring at the hole **18b** in the color filter layer **18** and the side faces (wall faces) of the wall structure **15** together with the alignment regulating force of the wall structure **15**. In this way, the liquid crystal molecules **21** are aligned axisymmetrically around the hole **18b** and the opening **14a** as the center. In the resultant axisymmetrically aligned domain, liquid crystal directors point in all directions (directions in the substrate plane), and thus, excellent viewing angle characteristics can be obtained.

[0106] As described above, the hole also serves to improve the transmittance of the color filter layer.

[0107] Although the action of the inclined electric field generated around the hole **18b** in the color filter layer **18** and

the opening **14a** and the alignment regulating force of the wall structure **15** were referred to in the above description, an inclined electric field is also generated around cuts formed at edges of the pixel electrode **6**, and the directions of the tilt of the liquid crystal molecules **21** are also defined with this inclined electric field.

[0108] Hereinafter, referring to **FIGS. 6A and 6B**, the mechanism with which an opening formed in the pixel electrode and an opening formed in the counter electrode effectively stabilize the center axis of axisymmetric alignment in the LCD device of an embodiment of the present invention will be described.

[0109] **FIGS. 6A and 6B** are views diagrammatically illustrating the aligned state of liquid crystal molecules (shown as line segments in **FIGS. 6A and 6B**) 200 msec after application of a voltage that gives a relative transmittance of 10% to a liquid crystal layer (3V in this case), together with equipotential lines of an electric field generated in the liquid crystal layer at that time, where **FIG. 6A** shows the case of providing no hole or opening in each pixel and **FIG. 6B** shows the case of providing a hole **18b** in a color filter layer **18** and an opening **14a** in a pixel electrode **6**. **FIGS. 6A and 6B** correspond to a cross-sectional view taken along line **6B-6B'** in **FIG. 1A** and **FIG. 2A**. **FIGS. 6A and 6B** show the results of an electric field simulation conducted under the conditions that the thickness of the liquid crystal layer is  $4.0\ \mu\text{m}$ , the dielectric constant of the liquid crystal material is  $-4.5$ , and the refractive indexes  $n_o=1.485$  and  $n_e=1.495$ .

[0110] As shown in **FIG. 6A**, in which the color filter layer **18** has no hole and neither a pixel electrode **6'** nor a counter electrode **19'** has an opening, the center axis of the axisymmetric alignment of liquid crystal molecules **21** may not be fixed effectively in a fixed region, failing to be formed in the center between the walls of the wall structure **15**.

[0111] By forming the hole **18b** in the color filter layer and the opening **14a** in the pixel electrode **6** near the center between the walls of the wall structure **15** as shown in **FIG. 6B**, the center axis of the axisymmetric alignment of the liquid crystal molecules **21** is fixed in the hole **18b** and the opening **14a** and thus stabilized. The liquid crystal molecules **21** located near the center of the liquid crystal domain (near the center between the walls of the wall structure **15**) are aligned vertically and serve together as the center axis of the axisymmetric alignment. This phenomenon occurs due to the action of an inclined electric field that is generated with attraction of the equipotential lines into the hole **18b** in the color filter layer **18** and the opening **14a** in the pixel electrode **6**, and also due to the shape effect of the hole **18b** in the color filter layer **18**.

[0112] The liquid crystal molecules **21**, staying roughly uniformly in their vertically aligned state immediately after the voltage application, gradually shift to axisymmetric alignment with time with the center axis being positioned at and around the center of the liquid crystal domain, and thus are fixed/stabilized. The shape of the hole **18b** in the color filter layer **18** and the opening **14a** in the pixel electrode **6** is preferably circular but not limited to this. To exert roughly equal alignment regulating force in all directions, the shape is preferably a polygon having four or more sides and also preferably a regular polygon.

[0113] In the embodiment of the present invention, the holes (depressions or through holes) in the color filter layer,

acting to fix/stabilize the center axes of axisymmetric alignment, can be formed during formation of the color filter layer **18** by patterning in a photolithographic process. Specifically, in exposure of a negative photosensitive resin film including R (red), G (green) and B (blue) color layers, a region smaller in exposure amount than the other region is formed at a predetermined position (position at which the hole is to be formed) in each pixel, and the resultant exposed photosensitive resin film is developed, to thereby form a hole at the predetermined position. The exposure amount can be adjusted with a known photomask such as a shading mask and a dimming mask.

[0114] The holes act not only to fix/stabilize the center axes of axisymmetric alignment by distorting equipotential lines, but also to improve the transmittance of the color filter layer, for example.

[0115] In the process of forming the holes in the color filter layer, the side faces of the holes can be stepped or slowly inclined by adopting multi-step exposure and half exposure using shading masks different in shape and size. By regulating the directions of alignment of liquid crystal molecules with such side faces, the effect of fixing/stabilizing the center axes of the axisymmetric alignment can be further improved.

[0116] According to the fabrication method described above, holes for fixing/stabilizing the positions of the center axes of the axisymmetric alignment can be formed during patterning of the color filter layer by photolithography in the process of fabricating the color filter substrate, only by changing the photomask, without the necessity of addition of a new step. This fabrication method is simpler compared with a fabrication method in which openings are formed in the counter electrode.

[0117] The construction of an LCD device according to the present invention will be described.

[0118] The LCD device shown in FIG. 7 includes: a backlight; a transfective liquid crystal panel **50**; a pair of polarizing plates **40** and **43** placed to face each other via the transfective liquid crystal panel **50**; a quarter wave plates **41** and **44** respectively placed between the polarizing plates **40** and **43** and the liquid crystal panel **50**; and phase plates **42** and **45** having negative optical anisotropy respectively placed between the wave plates **41** and **44** and the liquid crystal panel **50**. The liquid crystal panel **50** includes a vertically aligned liquid crystal layer **20** between a transparent substrate (active matrix substrate) **1** and a transparent substrate (counter substrate) **17**. As the liquid crystal panel **50**, one having the same construction as that of the LCD device **200** shown in FIGS. 2A and 2B is used.

[0119] The display operation of the LCD device shown in FIG. 7 will be briefly described.

[0120] In reflection-mode display, light incident from above passes through the polarizing plate **43** to be output as linearly polarized light. The linearly polarized light is changed to circularly polarized light with the quarter wave plate **44** placed so that the slower axis thereof forms  $45^\circ$  with the transmission axis of the polarizing plate **43**. The circularly polarized light passes through the color filter layer (not shown) formed on the substrate **17**. In the illustrated example, the phase plate **45** provides no phase difference for light incident in the normal direction.

[0121] During non-voltage application, in which liquid crystal molecules in the liquid crystal layer **20** are aligned roughly vertical to the substrate plane, incident light passes through the liquid crystal layer **20** with a phase difference of roughly 0 and is reflected with the reflective electrode formed on the lower substrate **1**. The reflected circularly polarized light passes again through the liquid crystal layer **20** and the color filter layer. The light then passes through the phase plate **45** having negative optical anisotropy as the circularly polarized light, to enter the quarter wave plate **44**, where the light is changed to linearly polarized light having a polarizing direction orthogonal to the polarizing direction given to the incident light after first passing through the polarizing plate **43**, and reaches the polarizing plate **43**. The resultant linearly polarized light fails to pass through the polarizing plate **43**, and thus black display is provided.

[0122] During voltage application, in which the liquid crystal molecules in the liquid crystal layer **20** are tilted toward the horizontal direction from the direction vertical to the substrate plane, the incident circularly polarized light is changed to elliptically polarized light due to birefringence of the liquid crystal layer **20**, and reflected with the reflective electrode formed on the lower substrate **1**. The polarized state of the reflected light is further changed during passing back through the liquid crystal layer **20**. The reflected light passes again through the color filter layer and then the phase plate **45** having negative optical anisotropy, to enter the quarter wave plate **44** as the elliptically polarized light. Accordingly, when reaching the polarizing plate **43**, the light is not linearly polarized light having a polarizing direction orthogonal to the polarizing direction given to the original incident light, and thus passes through the polarizing plate **43**. That is to say, by adjusting the applied voltage, the degree of the tilt of the liquid crystal molecules can be controlled, and thus the amount of reflected light allowed to pass through the polarizing plate **43** can be changed, to thereby enable grayscale display.

[0123] In transmission-mode display, the upper and lower polarizing plates **43** and **40** are placed so that the transmission axes thereof are orthogonal to each other. Light emitted from a light source is changed to linearly polarized light at the polarizing plate **40**, and then changed to circularly polarized light when being incident on the quarter wave plate **41** placed so that the slower axis thereof forms  $45^\circ$  with the transmission axis of the polarizing plate **40**. The circularly polarized light then passes through the phase plate **42** having negative optical anisotropy and is incident on the transmission region A of the lower substrate **1**. In the illustrated example, the phase plate **42** provides no phase difference for light incident in the normal direction.

[0124] During non-voltage application, in which liquid crystal molecules in the liquid crystal layer **20** are aligned roughly vertical to the substrate plane, the incident light passes through the liquid crystal layer **20** with a phase difference of roughly 0. That is, the light incident on the lower substrate **1** as circularly polarized light passes through the liquid crystal layer **20** and then the upper substrate **17** in this state. The light then passes through the upper phase plate **45** having negative optical anisotropy, to enter the quarter wave plate **44**. The lower and upper quarter wave plates **41** and **44** are placed so that the slower axes thereof are orthogonal to each other. Therefore, linearly polarized light orthogonal to the linearly polarized light at the polarizing

plate **40** comes from the upper quarter wave plate **44**. The linearly polarized light is then absorbed with the polarizing plate **43**, and thus black display is provided.

[0125] During voltage application, in which the liquid crystal molecules in the liquid crystal layer **20** are tilted toward the horizontal direction from the direction vertical to the substrate plane, the incident circularly polarized light is changed to elliptically polarized light due to birefringence of the liquid crystal layer **20**. The light then passes through the color filter layer **17**, the phase plate **45** having negative optical anisotropy, and the quarter wave plate **44** as the elliptically polarized light. Accordingly, when reaching the polarizing plate **43**, the light is not linearly polarized light orthogonal to the polarized component in the original incident light, and thus passes through the polarizing plate **43**. That is to say, by adjusting the applied voltage, the degree of the tilt of the liquid crystal molecules can be controlled, and thus the amount of light allowed to pass through the polarizing plate **43** can be changed, to thereby enable grayscale display.

[0126] The phase plate having negative optical anisotropy minimizes the amount of change in phase difference occurring with change of the viewing angle when the liquid crystal molecules are in the vertically aligned state, and thus suppresses black floating observed when the display device is viewed at a wide viewing angle. A biaxial phase plate unifying the functions of the phase plate having negative optical anisotropy and the quarter wave plate may be used.

[0127] When axisymmetrically aligned domains are used to implement the normally black mode that presents black display during non-voltage application and white display during voltage application, as the embodiment of the present invention, a polarizing plate-caused extinction pattern can be eliminated by placing a pair of quarter wave plates on the top and bottom of the LCD device (panel), and thus the brightness can be improved. Also, when axisymmetrically aligned domains are used to implement the normally black mode with upper and lower polarizing plates placed so that the transmission axes thereof are orthogonal to each other, it is theoretically possible to present black display of substantially the same level as that obtained when a pair of polarizing plates are placed under crossed nicols. Therefore, a considerably high contrast ratio can be obtained, and also, with the all-direction alignment of liquid crystal molecules, wide viewing angle characteristics can be attained.

[0128] The thicknesses  $d_t$  and  $d_r$  of the liquid crystal layer in the transmission region and the reflection region defined according to the present invention preferably has the relationship satisfying  $0.3 d_t < d_r < 0.7 d_t$ , more preferably  $0.4 d_t < d_r < 0.6 d_t$ , as is found from the dependence of the voltage-reflectance (transmittance) of the transmission region and the reflection region on the thickness of the liquid crystal layer shown in FIG. 8. If the thickness of the liquid crystal layer in the reflection region is smaller than the lower limit, the reflectance will be 50% or less of the maximum reflectance, failing to provide sufficiently high reflectance. If the thickness  $d_r$  of the liquid crystal layer in the reflection region is greater than the upper limit, the peak of the reflectance in the voltage-reflectance characteristics exists at a drive voltage different from that in the case of the transmission display. Also, the relative reflectance tends to be low at a white display voltage optimal for the transmis-

sion display. The reflectance is as low as 50% or less of the maximum reflectance, failing to provide sufficiently high reflectance. Since the optical length in the liquid crystal layer in the reflection region is double that in the transmission region, the birefringence anisotropy ( $\Delta n$ ) of the liquid crystal material and the panel cell thickness design are very important when the same design is made for both the transmission region and the reflection region.

[0129] Specific characteristics of the transfective LCD device of the embodiment of the present invention will be described as follows.

[0130] An LCD device having the construction shown in FIG. 7 was fabricated. As the liquid crystal cell **50**, one having the same construction as that of the LCD device **200** shown in FIGS. 2A and 2B was used. Holes (through holes) **230b** having a diameter of  $8 \mu\text{m}$  were formed in the color filter layer (thickness (color layer portion):  $1.8 \mu\text{m}$ ) of the counter color filter substrate. A transparent dielectric layer having no light scattering function was formed on the color filter substrate as the transparent dielectric layer **234**, and a resin layer having a continuous uneven surface was formed under the reflective electrode **211b**, to adjust the diffuse reflection characteristics in the reflection display. In the pixel electrode **211** of the TFT substrate, openings **214a** having a diameter of  $8 \mu\text{m}$  were formed at predetermined positions in the transmission region and the reflection region.

[0131] The vertical alignment films were formed by a known method using a known alignment film material. No rubbing was made. A liquid crystal material having negative dielectric anisotropy ( $\Delta n: 0.1$  and  $\Delta \epsilon: -4.5$ ) was used. In this example, the thicknesses  $d_t$  and  $d_r$  of the liquid crystal layer in the transmission region and the reflection region were set at  $4 \mu\text{m}$  and  $2.2 \mu\text{m}$ , respectively ( $d_r = 0.55 d_t$ ).

[0132] The LCD device of this example had a multilayer structure composed of a polarizing plate (observer side), a quarter wave plate (phase plate **1**), a phase plate having negative optical anisotropy (phase plate **2** (NR plate)), the liquid crystal layer (on the upper and lower sides thereof, the color filter substrate and the active matrix substrate were respectively placed), a phase plate having negative optical anisotropy (phase plate **3** (NR plate)), a quarter wave plate (phase plate **4**), and a polarizing plate (backlight side) in the order from the observer side. The upper and lower quarter wave plates (phase plates **1** and **4**) were placed so that the slower axes thereof were orthogonal to each other, and had a phase difference of 140 nm. The phase plates having negative optical anisotropy (phase plates **2** and **3**) had a phase difference of 135 nm. The two polarizing plates were placed so that the absorption axes thereof were orthogonal to each other.

[0133] A drive signal was applied to the thus-obtained LCD device (4V was applied across the liquid crystal layer) to evaluate the display characteristics.

[0134] The results of the visual angle—contrast characteristics are shown in FIG. 9. The viewing angle characteristics in the transparent display were roughly symmetric in all directions, the range  $CR > 10$  was as large as up to  $\pm 80^\circ$ , and the transmission contrast was as high as 300:1 or more at the front.

[0135] As for the characteristics of the reflection display, the reflectance evaluated with a spectral colorimeter

(CM2002 from Minolta Co., Ltd.) was about 8.6% (value in terms of the aperture ratio of 100%) with respect to a standard diffuse plate as the reference. The contrast value of the reflection display was 21, which was high compared with the case of the conventional LCD devices.

[0136] No roughness of display was observed in visual evaluation in a slanting direction in a grayscale level (level 2 in the eight levels of grayscale). On the contrary, for an LCD device fabricated under the same conditions except that no opening was formed in the pixel electrode or the counter electrode for comparison, roughness of display in a slanting direction was eminent in a grayscale level. In observation with an optical microscope with polarizing axes set orthogonal to each other, axisymmetrically aligned domains with their center axes aligned uniformly were recognized for the LCD device having electrode openings. For the latter LCD device having no opening, however, the center axes of some liquid crystal domains deviated from the centers of the sub-pixels, and it was confirmed that this variation in center axis position was a main cause of the roughness of display.

[0137] Samples of LCD devices, which are the same in construction as the LCD device shown in FIGS. 2A and 2B except that the openings 214a are not formed in the pixel electrode 211, and have holes different in depth in the color filter layer 230, were fabricated for evaluation of the grayscale response time and the effect of alignment recovery after pressing of the panel face. The thickness of the color filter layer was 1.8  $\mu\text{m}$  as described above. In three samples of LCD devices, the depth of the holes was 1.8  $\mu\text{m}$  (color layer through hole; Sample A), 0.8  $\mu\text{m}$  (about 44% of the thickness of the color layer; Sample B), and 0.35  $\mu\text{m}$  (about 19% of the thickness of the color layer; Sample C). In one sample (Sample D), no hole was formed in the color filter layer. The diameter of the holes was 8  $\mu\text{m}$  in all samples.

[0138] The grayscale response time was evaluated by measuring the time (msec) required for a change from level 3 to level 5 in the eight levels of grayscale at room temperature (25° C.). The alignment recovery after panel pressing was evaluated by measuring the time taken until alignment disturbance (an afterimage) was no more observed (alignment recovers) after the panel face was pressed with a fingertip during application of 4V (white display).

TABLE 1

Sample	Depth of "hole" ( $\mu\text{m}$ )	Grayscale response time (msec)	Recovery force after pressing
A	1.8	40	⊙(recovered within 5 sec)
B	0.8	45	○(recovered within 10 sec)
C	0.35	54	X(afterimage for 1 minute)
D	0	60	X(afterimage for several minutes)

[0139] As is found from Table 1, by forming holes in the color filter layer, the grayscale response time is shortened and the recovery force from pressing improves. To ensure sufficient recovery force enabling recovery in less than one minute after pressing, the depth of the holes is preferably about 20% or more of the thickness of the color filter layer (for example, 0.36  $\mu\text{m}$  or more), more preferably about 44% or more (for example, 0.8  $\mu\text{m}$  or more).

[0140] An LCD device having the color filter substrate used for Sample A and having openings in the pixel electrode was also evaluated. As a result, the grayscale response time (time required for a change from level 3 to level 5 in the eight levels of grayscale; msec) was 37 msec. This indicates that the response speed is further improved by providing openings in the pixel electrode.

[0141] The reduction of the front transmittance in the transmission mode of the sample having openings in the pixel electrode, with respect to that of any of the samples having no opening at all, was about 0.8%. The reduction in brightness was therefore a level too low to cause a problem. That is to say, by forming holes in the color filter layer and forming openings in the pixel electrode, obtained is the effect of fixing/stabilizing the positions of the center axes of axisymmetrically aligned domains, and this provides the effects such as reduction in the roughness of display in a slanting visual angle in a grayscale level, improvement in the response speed in grayscale display, and reduction in occurrence of an afterimage after pressing.

[0142] As described above, according to the present invention, an LCD device excellent in display quality can be implemented with a comparatively simple construction. The present invention is suitably applied to transmissive LCD devices and transfective (transmissive/reflective) LCD devices. In particular, transfective LCD devices are suitably used as display devices for mobile equipment such as mobile phones.

[0143] While the present invention has been described in preferred embodiments, it will be apparent to those skilled in the art that the disclosed invention may be modified in numerous ways and may assume many embodiments other than that specifically set out and described above. Accordingly, it is intended by the appended claims to cover all modifications of the invention that fall within the true spirit and scope of the invention.

[0144] This non-provisional application claims priority under 35 USC § 119(a) on Patent Application No. 2004-179889 filed in Japan on Jun. 17, 2004, the entire contents of which are hereby incorporated by reference.

What is claimed is:

1. A liquid crystal display device comprising a first substrate, a second substrate opposed to the first substrate, and a vertically aligned liquid crystal layer interposed between the first substrate and the second substrate,

wherein the liquid crystal display device has a plurality of pixels, each pixel including a first electrode formed on the first substrate, a second electrode formed on the second substrate, and the liquid crystal layer interposed between the first electrode and the second electrode,

the first substrate has a shading region in gaps between the plurality of pixels, and a wall structure is placed regularly on the surface of the first substrate facing the liquid crystal layer in the shading region,

the second substrate has a color filter layer on the surface of the second electrode farther from the liquid crystal layer, the color filter layer having at least one hole formed at a predetermined position in each pixel, and

at least one liquid crystal domain having axisymmetric alignment is formed in the liquid crystal layer when at

least a predetermined voltage is applied across the liquid crystal layer, and the center axis of the axisymmetric alignment of the at least one liquid crystal domain is formed in or near the at least one hole.

2. The liquid crystal display device of claim 1, wherein the at least one hole has a stepped or inclined side face.

3. The liquid crystal display device of claim 1, wherein the first electrode has at least one first opening formed at a predetermined position in the pixel, and

one end of the center axis of the axisymmetric alignment of the at least one liquid crystal domain is located in or near the at least one first opening, while the other end is located in or near the at least one hole.

4. The liquid crystal display device of claim 3, wherein the at least one first opening and the at least one hole in the color filter layer are placed to at least overlap each other via the liquid crystal layer.

5. The liquid crystal display device of claim 1, wherein the first electrode has at least one cut.

6. The liquid crystal display device of claim 1, wherein the second electrode has at least one second opening formed at a position corresponding to the at least one hole in the color filter layer.

7. The liquid crystal display device of claim 1, wherein a support for defining the thickness of the liquid crystal layer is placed in the shading region located in gaps between the plurality of pixels.

8. The liquid crystal display device of claim 1, wherein the first electrode includes a transparent electrode defining a transmission region and a reflective electrode defining a reflection region, and the thickness  $dt$  of the liquid crystal layer in the transmission region and the thickness  $dr$  of the liquid crystal layer in the reflection region satisfy the relationship  $0.3 dt < dr < 0.7 dt$ .

9. The liquid crystal display device of claim 1, wherein the first electrode includes a transparent electrode defining a transmission region and a reflective electrode defining a reflection region, the at least one liquid crystal domain includes a liquid crystal domain formed in the transmission region, the at least one hole includes a hole corresponding to the center axis of the liquid crystal domain formed in the transmission region, and

the first electrode has a plurality of cuts formed point-symmetrically with respect to the hole.

10. The liquid crystal display device of claim 8, wherein a transparent dielectric layer is selectively formed on the second substrate in the reflection region.

11. The liquid crystal display device of claim 10, wherein the transparent dielectric layer has a function of scattering light.

12. The liquid crystal display device of claim 8, wherein the optical density of the color filter layer in the reflection region is lower than that in the transmission region.

13. The liquid crystal display device of claim 1, further comprising: a pair of polarizing plates placed to face each other via the first substrate and the second substrate; and at least one biaxial optical anisotropic medium layer placed between the first substrate and one of the pair of polarizing plates and/or between the second substrate and the other polarizing plate.

14. The liquid crystal display device of claim 1, further comprising: a pair of polarizing plates placed to face each other via the first substrate and the second substrate; and at least one uniaxial optical anisotropic medium layer placed between the first substrate and one of the pair of polarizing plates and/or between the second substrate and the other polarizing plate.

15. A fabrication method for a liquid crystal display device of claim 1, comprising the step of forming the color filter layer,

wherein the step of forming the color filter layer comprises the steps of:

forming a negative photosensitive resin film on the second substrate;

exposing the negative photosensitive resin film to light so that at least one region smaller in exposure amount than the other region is formed at a predetermined position of the negative photosensitive resin film in each pixel; and

developing the exposed photosensitive resin film to form the at least one hole at the predetermined position.

16. The method of claim 15, wherein the step of exposing the negative photosensitive resin comprises the step of forming a region in which the exposure amount changes stepwise or changes continuously, and

the at least one hole having a stepped or inclined side face is formed by developing the negative photosensitive resin layer.

\* \* \* \* \*

专利名称(译)	液晶显示装置及其制造方法		
公开(公告)号	<a href="#">US20050280754A1</a>	公开(公告)日	2005-12-22
申请号	US11/153920	申请日	2005-06-16
[标]申请(专利权)人(译)	KUME YASUHIRO 大西宪明 玉井和彦 KOJIMA博明 永江NOBUKAZU		
申请(专利权)人(译)	KUME YASUHIRO 大西宪明 玉井和彦 KOJIMA博明 永江NOBUKAZU		
当前申请(专利权)人(译)	夏普株式会社		
[标]发明人	KUME YASUHIRO ONISHI NORIAKI TAMAI KAZUHIKO KOJIMA HIROAKI NAGAE NOBUKAZU		
发明人	KUME, YASUHIRO ONISHI, NORIAKI TAMAI, KAZUHIKO KOJIMA, HIROAKI NAGAE, NOBUKAZU		
IPC分类号	G02F1/1333 G02F1/1335 G02F1/1339 G02F1/1368 G02F1/139		
CPC分类号	G02F1/133514 G02F1/133707 G02F1/1393 G02F1/1368 G02F1/13394		
优先权	2004179889 2004-06-17 JP		
其他公开文献	US7728937		
外部链接	<a href="#">Espacenet</a> <a href="#">USPTO</a>		

摘要(译)

液晶显示装置包括第一基板，与第一基板相对的第二基板，以及插入在第一基板和第二基板之间的垂直取向的液晶层，并且具有多个像素，每个像素包括形成在第一基板上的第一电极形成在第二基板上的第二电极，以及插入在第一和第二电极之间的液晶层。第一基板在多个像素之间的间隙中具有阴影区域，并且壁结构规则地放置在阴影区域中面对液晶层的第一基板的表面上。第二基板的滤色器层具有形成在每个像素中的预定位置处的至少一个孔。当在液晶层上施加至少预定电压时，在液晶层中形成至少一个具有轴对称取向的液晶畴，并且在孔中或孔附近形成轴对称取向的液晶畴的中心轴。彩色滤光层。

