



(19) **United States**

(12) **Patent Application Publication**  
**ARAI et al.**

(10) **Pub. No.: US 2010/0157222 A1**  
(43) **Pub. Date: Jun. 24, 2010**

(54) **IN-PLANE SWITCHING TYPE LIQUID CRYSTAL DISPLAY DEVICE**

(30) **Foreign Application Priority Data**

Sep. 27, 2006 (JP) ..... 2006-263223

(75) Inventors: **Norihiro ARAI**, Tokyo (JP);  
**Kunpei Kobayashi**, Tokyo (JP);  
**Toshiharu Nishino**, Tokyo (JP)

**Publication Classification**

(51) **Int. Cl.**  
**G02F 1/1337** (2006.01)  
**G02F 1/1343** (2006.01)

(52) **U.S. Cl.** ..... **349/123; 349/141**

Correspondence Address:  
**FRISHAUF, HOLTZ, GOODMAN & CHICK, PC**  
**220 Fifth Avenue, 16TH Floor**  
**NEW YORK, NY 10001-7708 (US)**

(57) **ABSTRACT**

A liquid crystal display device comprises a pair of substrates subjected to an aligning treatment in mutually parallel but opposite directions, a liquid crystal layer interposed between the pair of substrates, a first electrode bent into a “<” shape, and a second electrode formed via an insulating film with the first electrode. The first electrode comprises one linear section and another linear section that extend in directions that intersect the alignment treatment direction at different angles, a bent section that is provided at each end where the one linear section and the other linear section adjacent to each other and that extends in a direction that intersects the alignment treatment direction at an angle that is greater than each of the intersecting angles of the one linear section and the other linear section and the alignment treatment direction with respect to the alignment treatment directions.

(73) Assignee: **CASIO COMPUTER CO., LTD.**,  
Tokyo (JP)

(21) Appl. No.: **12/716,864**

(22) Filed: **Mar. 3, 2010**

**Related U.S. Application Data**

(62) Division of application No. 11/861,991, filed on Sep. 26, 2007.

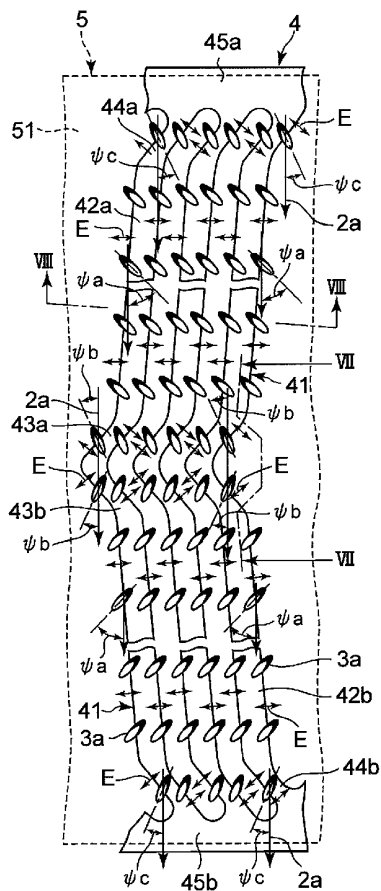

FIG. 1

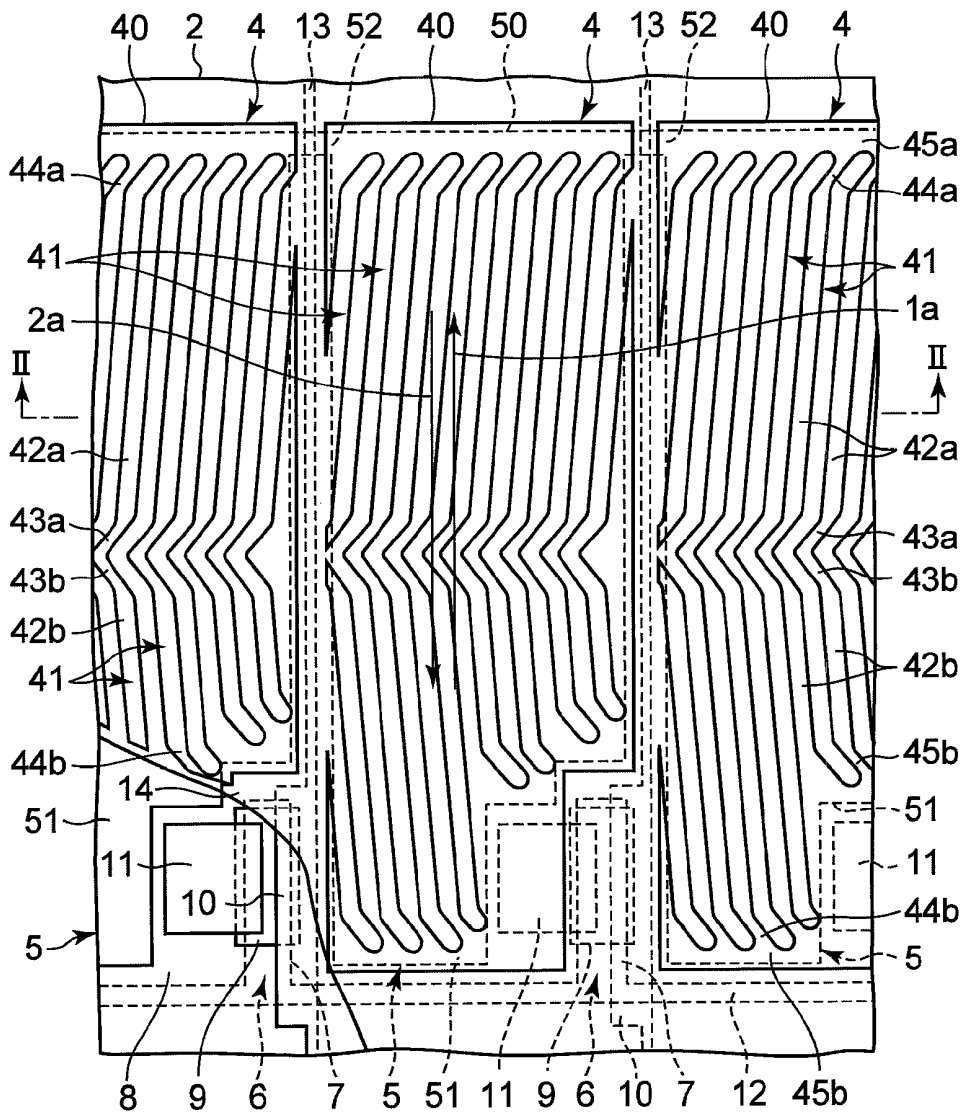

FIG. 2

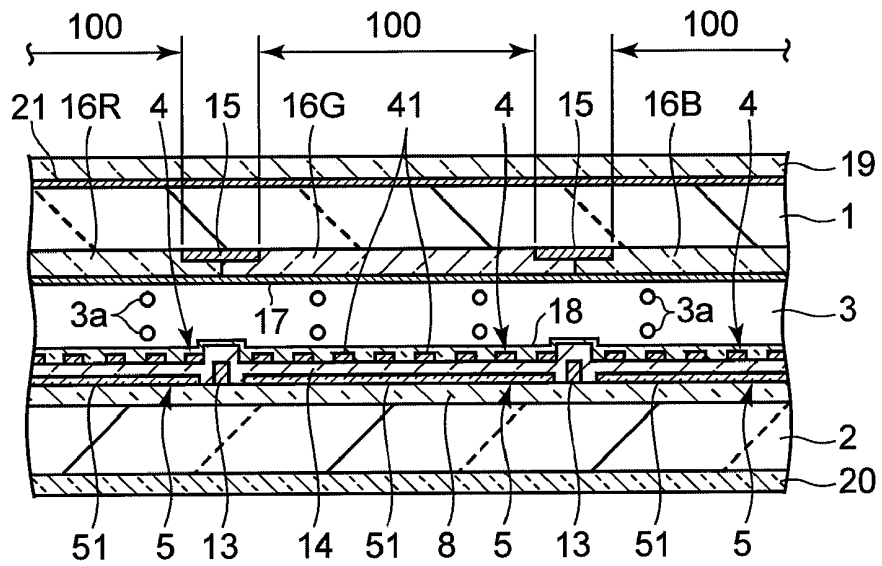

FIG. 3

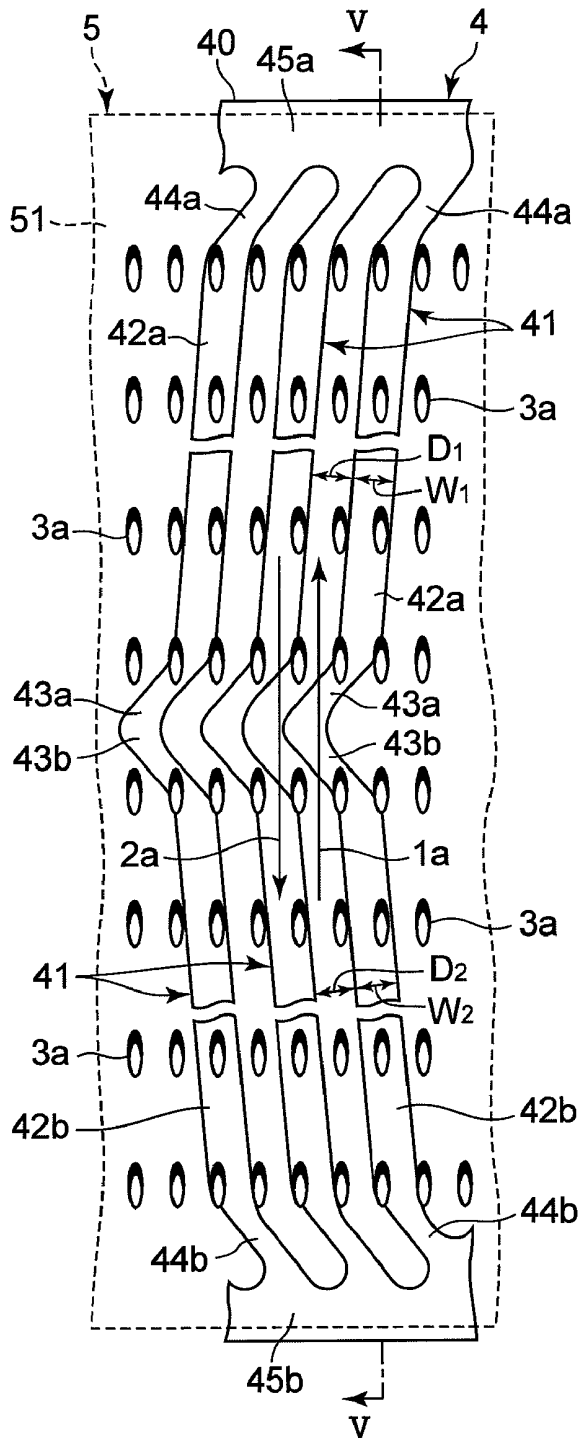



FIG. 5

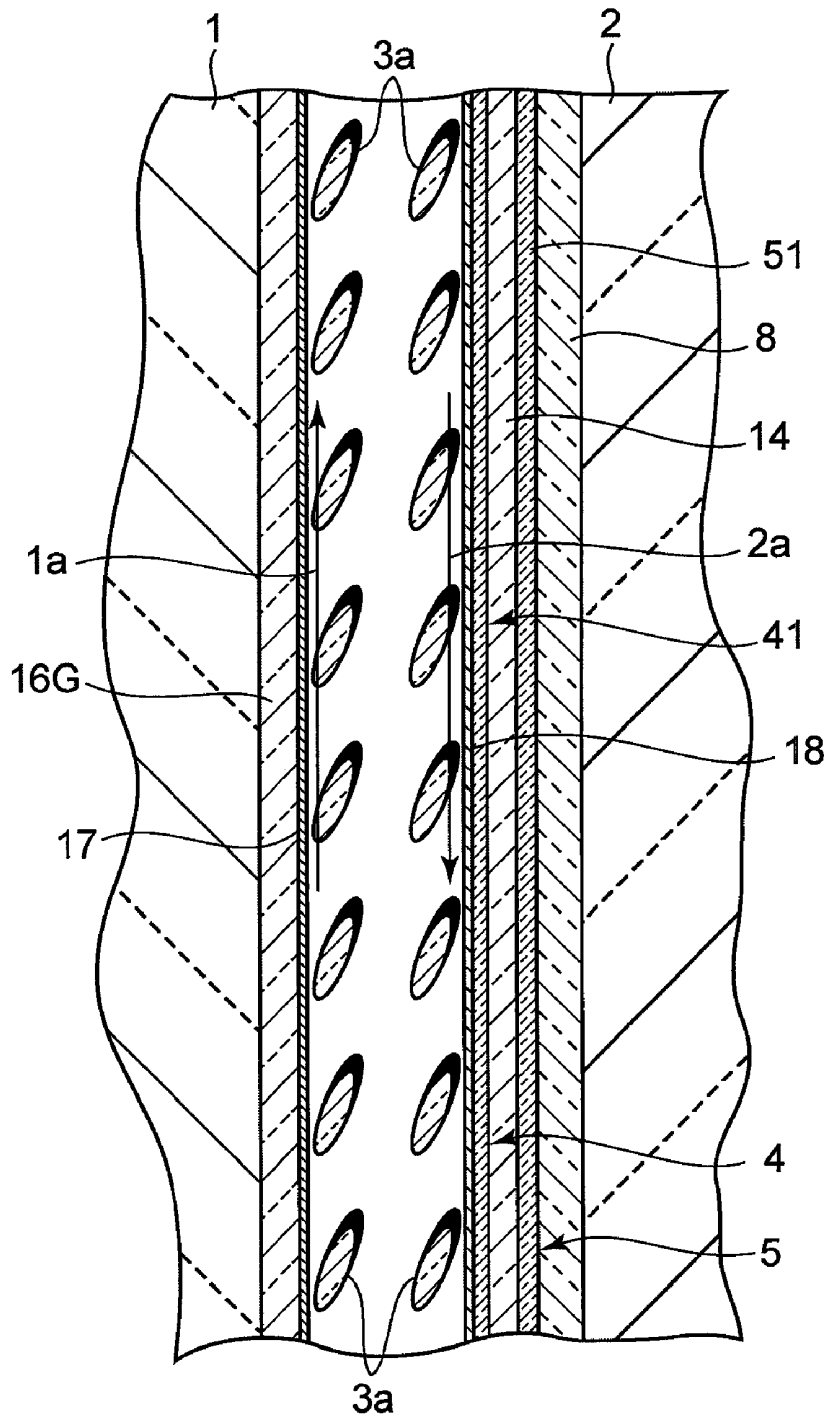

FIG. 6

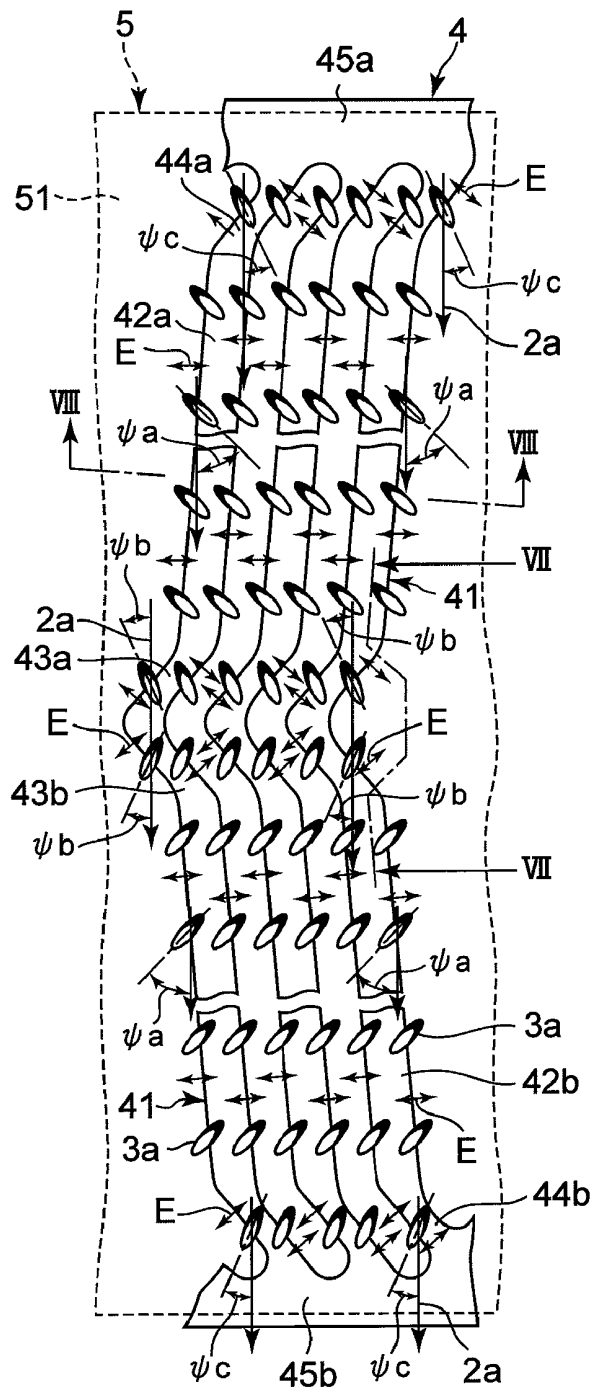

FIG. 7

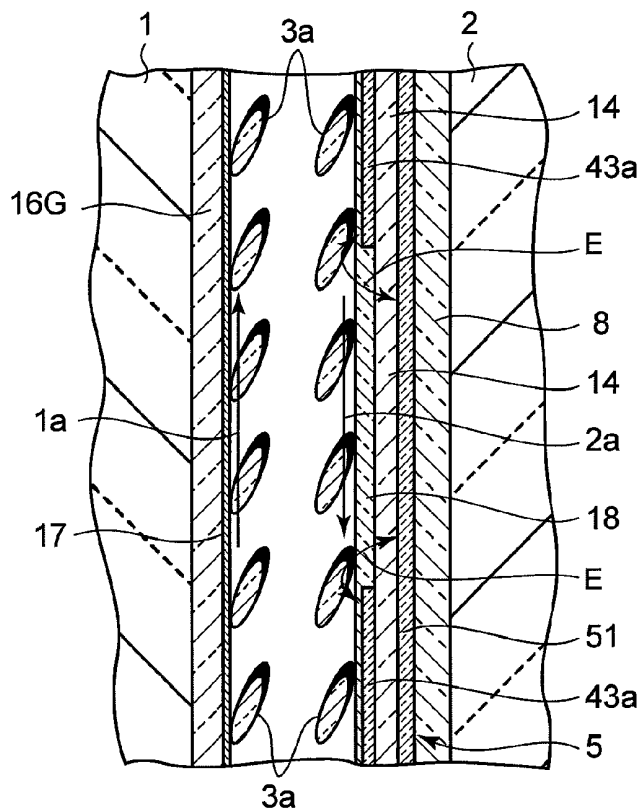

FIG. 8

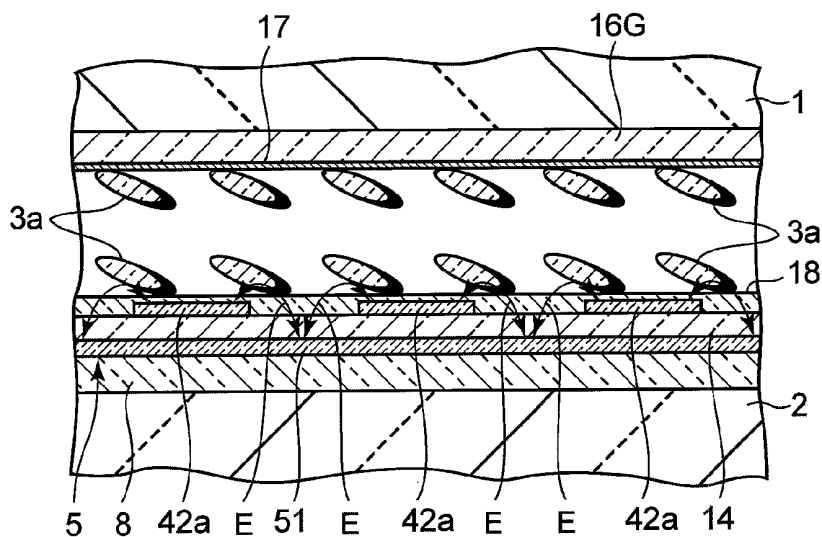

FIG. 9

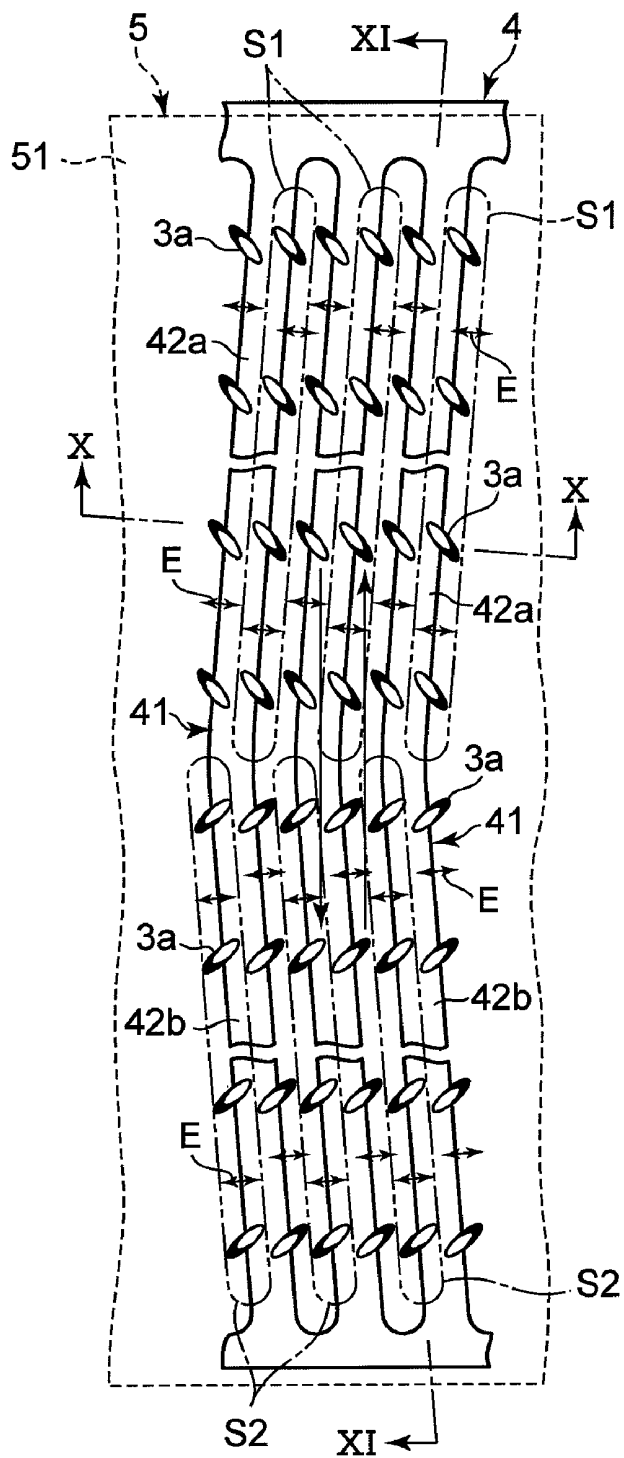

FIG.10

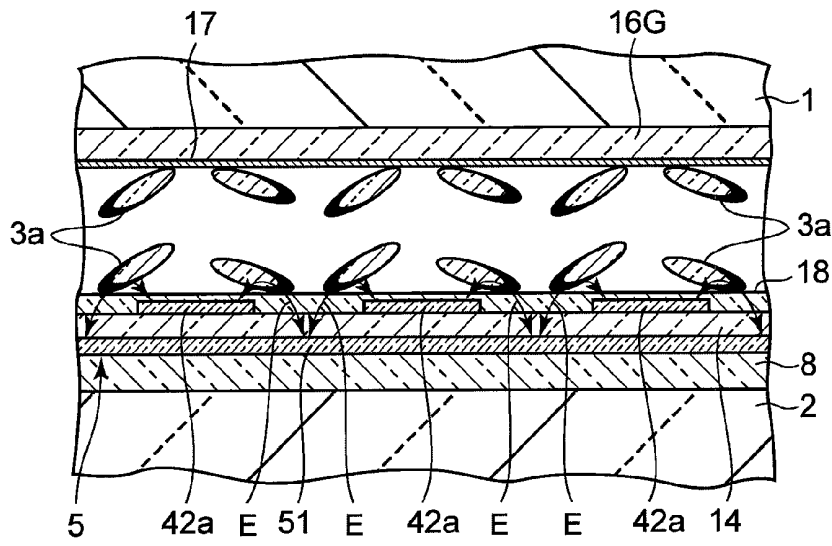
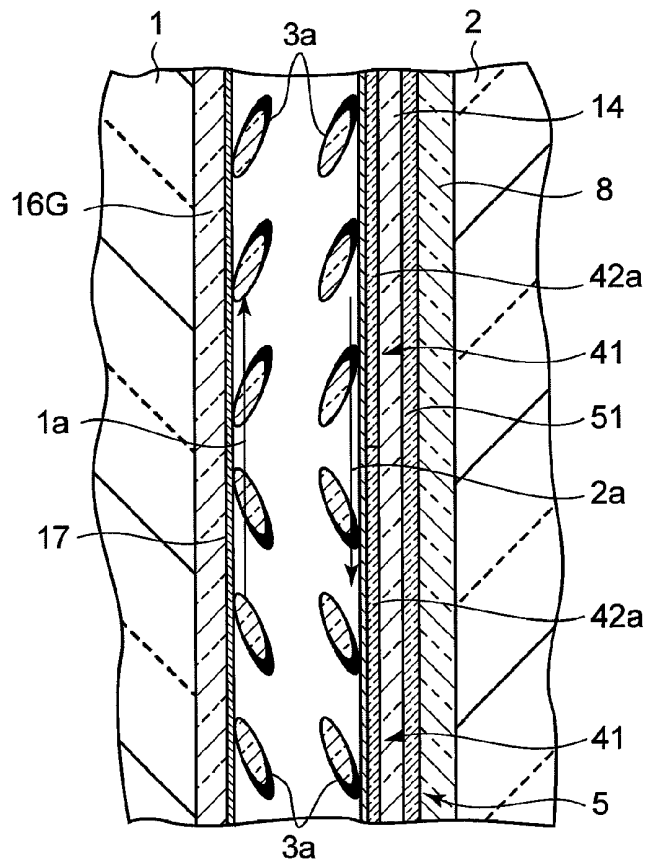

FIG.11



## IN-PLANE SWITCHING TYPE LIQUID CRYSTAL DISPLAY DEVICE

### CROSS-REFERENCE TO RELATED APPLICATIONS

**[0001]** The present application is a Divisional Application of U.S. application Ser. No. 11/861,991 filed Sep. 26, 2007, which is based on Japanese Patent Application No. 2006-263223 filed on Sep. 27, 2006, the disclosures of both of which are incorporated herein by reference.

### BACKGROUND OF THE INVENTION

**[0002]** 1. Field of the Invention

**[0003]** The present invention relates to a liquid crystal display device that controls the orientation of liquid crystal molecules using a transversal electric field.

**[0004]** 2. Description of the Related Art

**[0005]** Known liquid crystal display devices include an In-plane Switching (IPS) type liquid crystal display device that controls the orientation of liquid crystal molecules using an electric field parallel to the substrates that constitute the liquid crystal display device.

**[0006]** This liquid crystal display device comprises a pair of substrates arranged opposite each other at a predetermined gap, having been subjected to an aligning treatment in mutually parallel but opposite directions on each of the mutually opposed inner surfaces and, in the gap therebetween, a liquid crystal layer interposed substantially in parallel with the substrate surfaces, with the long axes of the liquid crystal molecules aligned in the direction of the aligning treatment. A pixel electrode in which a plurality of bent electrodes long and narrow in shape is formed in parallel at a distance from one another in a predetermined area for forming a single pixel is provided on the inner surface of one of the substrates of the pair of substrates, and an opposing electrode for generating an electric field that changes the orientation of the long axes of the liquid crystal molecules between the plurality of electrodes of the pixel electrode to an orientation that is substantially parallel to the substrate surfaces when voltage is applied between the opposing electrode and the pixel electrode is provided on the other substrate, in isolation from the pixel electrode.

**[0007]** This In-plane Switching (IPS) type liquid crystal display device generates an electric field parallel to the substrates that corresponds to display data between the pixel electrode and the opposing electrode. When an electric field is applied parallel to the substrate, the In-plane Switching (IPS) type liquid crystal display device controls on an inner surface substantially parallel with the substrate surfaces the orientation of the long axes of the liquid crystal molecules of a plurality of pixels comprising an area corresponding to the pixel electrode and opposing electrode, and displays an image.

**[0008]** Now, in the In-plane Switching (IPS) type liquid crystal display device, as described in Unexamined Japanese Patent Application KOKAI Publication No. 2002-182230, the plurality of bent electrodes of the first electrode is formed into a shape bent into a “<” shape to decrease the viewing angle dependability of the display and achieve a display having a wide viewing angle. That is, the orientation of the electric field parallel to the substrates that is generated between the opposing electrode and one of the electrodes of the two sections on either side of the bent section of the “<”

shape, and the orientation of the electric field parallel to the substrates that is generated between the other linear section and the second electrode are made to differ from each other. With such an arrangement, the pixel electrode is formed so that the liquid crystal molecules are arranged in two different directions within each pixel.

**[0009]** However, in the In-plane Switching (IPS) type liquid crystal display device in which the plurality of electrodes of the first electrode are formed into a shape that is bent into a “<” shape, the problem arises that, when a strong electric field parallel to the substrates is generated, the orientation of the liquid crystal molecules within each pixel becomes non-uniform and, as a result of these pixels, display unevenness occurs.

### SUMMARY OF THE INVENTION

**[0010]** The liquid crystal display device of the present invention comprises:

**[0011]** a pair of substrates arranged opposite each other at a predetermined gap, having been subjected to an aligning treatment in mutually parallel directions on each of the mutually opposed inner surfaces;

**[0012]** a liquid crystal layer interposed in the gap between the pair of substrates and arranged substantially in parallel with the surfaces of the substrates, with the long axis of the liquid crystal molecule in alignment with the direction of the aligning treatment;

**[0013]** a plurality of first electrodes provided on one of the mutually opposed inner surfaces of the pair of substrates, comprising one linear section and another linear section that extend in directions that intersect the direction of the aligning treatment at different angles in each predetermined region for forming a single pixel, a bent section that is provided at each end where the one linear section and the other linear section adjacent to each other and that extends in a direction that intersects the direction of the aligning treatment at an angle greater than each of the intersecting angles of the one linear section and the other linear section and the direction of the aligning treatment with respect to the direction of the aligning treatment, and a connection section that connects these bent sections;

**[0014]** and a second electrode that is arranged in isolation from the first electrode on the inner surface of the one substrate, and that generates with the first electrode an electric field parallel to the substrates for changing the orientation of the long axes of the liquid crystal molecules to within a plane that is substantially parallel with the surfaces of the substrates.

### BRIEF DESCRIPTION OF THE DRAWINGS

**[0015]** FIG. 1 is a plan view that shows a section of one substrate of a liquid crystal display device according to an example of the present invention;

**[0016]** FIG. 2 is a cross-sectional view that shows a cross-section of the liquid crystal display device shown in FIG. 1 cut along line II-II;

**[0017]** FIG. 3 is an enlarged plan view showing an enlarged section of the pixel electrode and opposing electrode of the liquid crystal display device shown in FIG. 1;

**[0018]** FIG. 4 is an enlarged plan view shown an enlarged one bent electrode of the pixel electrode of the liquid crystal display device shown in FIG. 1;

[0019] FIG. 5 is an enlarged cross-sectional view showing an enlarged cross-section of the liquid crystal display device shown in FIG. 1 cut along line V-V of FIG. 3;

[0020] FIG. 6 is a plan view showing the orientation of the liquid crystal molecules of each section within one pixel when an electric field parallel to the substrates is generated between the pixel electrode and opposing electrode;

[0021] FIG. 7 is an enlarged cross-sectional view showing an enlarged cross-section of the liquid crystal display device shown in FIG. 1 cut along line VII-VII of FIG. 6;

[0022] FIG. 8 is an enlarged cross-sectional view showing an enlarged cross-section of the liquid crystal display device shown in FIG. 1 cut along line VIII-VIII of FIG. 6;

[0023] FIG. 9 is a plan view that shows a comparison example where a plurality of bent electrodes of the pixel electrode are formed into a "<" shape where two electrode sections directly connect, and shows the orientation of the liquid crystal molecules of each section within one pixel when an electric field parallel to the substrates is generated between the pixel electrode and opposing electrode;

[0024] FIG. 10 is an enlarged cross-sectional view showing an enlarged cross-section of the liquid crystal display device shown in FIG. 9 cut along line X-X of FIG. 9;

[0025] FIG. 11 is an enlarged cross-sectional view showing an enlarged cross-section of the comparison example shown in FIG. 9 cut along line XI-XI of FIG. 9.

#### DETAILED DESCRIPTION OF THE PREFERRED EMBODIMENTS

[0026] FIG. 1 to FIG. 8 illustrate an example of the present invention. FIG. 1 is a plan view showing a section of one substrate of a liquid crystal display device, and FIG. 2 is a cross-sectional view showing a cross-section of the liquid crystal display device shown in FIG. 1 cut along line II-II.

[0027] This liquid crystal display device, as shown in FIG. 1 and FIG. 2, comprises a pair of transparent substrates 1 and 2 arranged opposite each other at a predetermined gap on an observed side (upper side in FIG. 2) and a side opposite that side, and a liquid crystal layer 3 interposed in the gap between the pair of substrates 1 and 2. First and second transparent electrodes 4 and 5 for generating an electric field that is substantially parallel to the surfaces of the substrates 1 and 2 when voltage is applied are formed in isolation from each other on one of the two mutually opposed inner surfaces of the pair of substrates 1 and 2, such as on the inner surface of the substrate 2 of the side opposite the observed side, for example. One of the plurality of first transparent electrodes 4 and the second transparent electrode 5 are arranged opposite each other, and a single pixel 100 that controls the orientation of the long axes of the liquid crystal molecules of the liquid crystal layer 3 is defined by the area where the electric field parallel to the substrates is generated between these electrodes. These pixels are arranged in plurality in a matrix shape. A pair of polarizing plates 19 and 20 of the observed side and the side opposite the observed side are disposed on the outer surface of the pair of substrates 1 and 2.

[0028] Hereinafter, the substrate 1 of the observed side is referred to as the "front substrate," the substrate 2 on the side opposite the observed side is referred to as the "back substrate," the polarizing plate 19 of the observed side arranged on the outer surface of the front substrate 1 is referred to as the "front side polarizing plate," and the polarizing plate 20 of the opposite side arranged on the outer surface of the back substrate 2 is referred to as the "back side polarizing plate."

[0029] The pair of substrates 1 and 2 are joined via a frame-shaped sealing material (not shown), and the liquid crystal layer 3 is interposed in the area of the gap between the pair of substrates 1 and 2 that is enclosed by the sealing material.

[0030] This liquid crystal display device is an active matrix display device. Of the first and second electrodes 44 provided in isolation from each other on the inner surface of the back substrate 2, a first electrode 4 is a plurality of pixel electrodes arranged in a matrix shape in a row direction (horizontally on the screen) and a column direction (vertically on the screen). A second electrode 5 is an opposing electrode arranged on a per row basis correspondingly to each pixel electrode 4 of that row.

[0031] Then, a plurality of active elements 6 arranged correspondingly to the plurality of pixels 100, a plurality of scan lines 12 arranged per pixel row comprising the plurality of pixels 100 arranged in the row direction, and a plurality of signal lines 13 arranged per pixel row comprising the plurality of pixels 100 arranged in the row direction are provided on the inner surface of the back substrate 2.

[0032] The active element 6 comprises an input electrode 10 and an output electrode 11 of a signal, and a control electrode 7 that controls the conduction between the input electrode 10 and the output electrode 11. The control electrode 7 is connected to the scan line 12 at each row, the input electrode 10 is connected to the signal line 13 at each column, and the output electrode 11 is connected to the pixel electrode 4.

[0033] The active element 6 is, for example, a TFT (thin film transistor), and comprises a control electrode (gate electrode) 7 formed on the surface of the back substrate 2, a transparent gate insulating film 8 formed on roughly the entire surface of the back substrate 2 covering the control electrode 7, an i-type semiconductor film 9 formed opposite the control electrode 7 on the gate insulating film 8, and an input electrode (drain electrode) 10 and output electrode (source electrode) 11 provided via an n-type semiconductor film (not shown) on both side sections of the i-type semiconductor film 9. hereinafter, the active elements 6 is referred to as "TFT".

[0034] Each of the plurality of scan lines 12 is formed on the surface of the back substrate 2 along one side (the bottom side in FIG. 1) of each pixel row in parallel with the pixel row, respectively connected to the gate electrode 7 of the TFT 6 of each row. Each of the plurality of signal lines 13 is formed along one side (the left side of FIG. 1) of each pixel column in parallel with the pixel column above the gate insulating film 8, respectively connected to the drain electrode 10 of the TFT 6 of each column.

[0035] The terminal alignment section (not shown) extending toward the outside of the front substrate 1 is formed on the border of the back substrate 2, and the plurality of scan lines 12 and the plurality of signal lines 13 are connected to a plurality of scan line terminals and signal line terminals provided on the terminal alignment section.

[0036] Then, the plurality of pixel electrodes 4 is formed above a transparent interlayer insulating film 14 formed on the front surface (not shown) of the back substrate 2, covering the plurality of TFT 6 and signal lines 13, and the opposing electrode 5 is formed above the gate insulating film 8. That is, the opposing electrode 5 is positioned farther toward the back substrate 2 side than the plurality of pixel electrodes 4, in isolation from the plurality of pixel electrodes 4 by the interlayer insulating film 14.

[0037] Each of the plurality of pixel electrodes **4** is formed in, for example, each region of a vertically long rectangular shape having a greater height along the vertical direction than the width along the horizontal direction of the screen, in a predetermined region for forming a single pixel **100**, and comprises a first transparent conductive film (ITO film, for example) **40** that is formed in parallel with and at a distance from a plurality of bent electrodes **41** long and narrow in shape, having a length extending across roughly the entire length in the height direction of the region.

[0038] The plurality of bent electrodes **41** of the pixel electrode **4** is formed by providing a plurality of slits in the first conductive film **40**. Then, these bent electrodes **41** are connected to common connection sections **45a** and **45b** formed on both end borders of the first conductive film **40**, at the respective ends.

[0039] Then, one end side of the common connection section **45b** of one end border (bottom end border of FIG. 1) of the first conductive film **40** overlaps the source electrode **11** of the TFT **6** via the interlayer insulating film **14**. This first conductive film **40** is connected to the source electrode **11** in a connecting hole (not shown) provided on the interlayer insulating film **14**.

[0040] The opposing electrode **5** is provided on a per pixel row basis across the total length thereof, and comprises a second transparent electrode film (for example, ITO film) **50** formed into a shape corresponding to the entire area of the plurality of pixels **100** of each row.

[0041] The second conductive film **50**, as shown in FIG. 1, is patterned, forming a vertically long, rectangular opposing section **51** corresponding to the pixel shape in each area respectively corresponding to the plurality of pixels **100** of each row. Then, these opposing sections **51** are formed into a shape connected by the common connection section **52** of the side (the top end of the pixel **100** in the figure) opposite the side where the scan line **12** is established.

[0042] The second conductive film **50** may also be formed to a width corresponding to the height of the pixel **100**, covering the entire length of the pixel row. With this arrangement, the second conductive film **50** is formed across the top of the plurality of signal lines **13**, and the intersecting section of the second conductive film **50** and the signal line **13** is insulated by an insulating film (not shown) covering the signal line **13**.

[0043] Then, the plurality of second conductive films **50** respectively corresponding to each pixel row is commonly connected (not shown) on the outside of the display region where the plurality of pixel electrodes **4** is arranged. Further, the common connection section of the second conductive film **50** is connected to an opposing electrode terminal provided on the terminal alignment section of the back substrate **2**.

[0044] The opposing electrode **5** comprising the second conductive film **50** generates an electric field parallel to the substrates that changes the orientation of the long axis of the liquid crystal molecule **3a** to an orientation substantially parallel with the surfaces of the substrates **1** and **2**, between the plurality of bent electrodes **41** of the pixel electrode **4** when voltage is applied between the opposing electrode **5** and the pixel electrode **4**.

[0045] On the other hand, a light shielding film **15** corresponding to the plurality of TFT **6** and the areas between the plurality of pixels **100** is formed on the inner surface of the front substrate **1**. Color filters **16R**, **16G**, and **16B** of the three

colors red, blue, and green are provided correspondingly to the respective plurality of pixels **100**, on the light shielding film **15**.

[0046] Furthermore, horizontal alignment films **17** and **18** of a polyimide film, etc., that align the liquid crystal molecule **3a** of the liquid crystal layer **3** so that its long axis is substantially parallel with the surfaces of the substrates **1** and **2**, are formed on the inner surface of the front substrate **1**, respectively covering the color filters **16R**, **16G**, and **16B** provided on the front substrate **1** and the plurality of pixel electrodes **4** provided on the back substrate **2**.

[0047] Then, the inner surfaces of the pair of substrates **1** and **2** are each subjected to an aligning treatment in mutually parallel but opposite directions by rubbing the film surfaces of the alignment films **17** and **18**, respectively, in predetermined directions.

[0048] FIG. 3 is an enlarged plan view showing an enlarged section of the pixel electrode **4** and the opposing electrode **5**, and FIG. 4 is an enlarged plan view showing an enlarged bent electrode **41** of the pixel electrode **4**.

[0049] In FIG. 1, FIG. 3, and FIG. 4, **1a** indicates the aligning treatment direction of the inner surface of the front substrate **1** (rubbing direction of the horizontal alignment film **17**), and **2a** indicates the aligning treatment direction of the inner surface of the back substrate **2** (rubbing direction of the horizontal alignment film **18**), respectively. In this example, the vertical alignment film **17** of the inner surface of the front substrate **1** is aligned, via the aligning treatment, parallel to the vertical direction of the screen, from the bottom to the top of the screen, and the vertical alignment film **18** of the inner surface of the back substrate **2** is aligned, via the aligning treatment, parallel to the vertical direction of the screen, from the top to the bottom of the screen.

[0050] Then, each of the plurality of bent electrodes **41** of the pixel electrode **4** is formed so that two linear sections **42a** and **42b** intersect the aligning treatment directions **1a** and **2a**, respectively, at different angles, as shown in FIG. 3 and FIG. 4. Further, at the center of the unit region of the rectangular shape in the vertical direction, the plurality of bent electrodes **41** are formed so that they substantially bend into a “<” shape connected at the section where the two linear sections **42a** and **42b** intersect. Then, in the section where the two linear sections **42a** and **42b** connect, a bent section **43a** wherein the side connected to one linear section **42a** bends in a direction in which the incline angle with respect to the aligning treatment directions **1a** and **2a** increases with respect to the one linear section **42a**, and a bent section **43b** wherein the side connected to the other linear section bends in a direction in which the incline angle with respect to the aligning treatment directions **1a** and **2a** increases with respect to the other linear section **42b** are provided. The connection section that connects the bent sections **43a** and **43b**, which connect the two linear sections **42a** and **42b**, is formed in a circular arc shape where one side border and the other side border smoothly connect.

[0051] That is, the bent electrode **41** is formed from the two linear sections **42a** and **42b** having first inclines that differ in incline orientation with respect to the aligning treatment directions **1a** and **2a**, and the bent sections **43a** and **43b** having second inclines with incline angles that are greater than the first incline and differ in incline orientation with respect to the aligning treatment directions **1a** and **2a**. Fur-

ther, the bent electrode **41** is continually formed with the connection section where these bent sections **43a** and **43b** connect to each other.

[0052] The two linear sections **42a** and **42b** of the bent electrode **41** are formed at substantially the same width. The ratio of a distance  $D_1$  between the neighboring one linear sections **42a** and **42a** of the bent electrode **41** to a width  $W_1$  of the one linear section **42a** is set to  $D_1/W_1$ , and the ratio of a distance  $D_2$  between the neighboring one linear sections **42b** and **42b** of the bent electrode **41** to a width  $W_2$  of the other linear section **42b** is set to  $D_2/W_2$ , with each set to 1/3 to 3/1, preferably to 1/1.

[0053] Further, given an incline angle  $\theta_a$  of the two linear sections **42a** and **42b** of the plurality of bent electrodes **41** of the pixel electrode **4** with respect to the aligning treatment directions **1a** and **2a**, and an incline angle  $\theta_b$  of the two bent sections **43a** and **43b** connecting the two linear sections **42a** and **42b** with respect to the aligning treatment directions **1a** and **2a**,  $\theta_a$  and  $\theta_b$  are set to:

[0054]  $0^\circ < \theta_a < 20^\circ$

[0055]  $20^\circ < \theta_b < 40^\circ$

[0056] Furthermore, given a length  $L_a$  of the two linear sections **42a** and **42b**, and a length  $L_b$  of the two bent sections **43a** and **43b** connecting the two linear sections **42a** and **42b**, the lengths  $L_a$  and  $L_b$  are set so that:

[0057]  $L_a > nL_b$  ( $n$ : 3 to 5)

[0058]  $10L_b > L_a > 4L_b$ .

[0059] Further, end bent sections **44a** and **44b** respectively connected to the linear sections **42a** and **42b** and bent in a direction where the incline angles with respect to the aligning treatment directions **1a** and **2a** increase with respect to the linear sections **42a** and **42b** are respectively formed at the ends of the side opposite the end where the two linear sections **42a** and **42b** of the plurality of bent electrodes **41** of the pixel electrode **4** adjacent to each other. Then, the connecting sections of these end bent sections **44a** and **44b** and the linear sections **42a** and **42b** are each formed into a circular arc where one side border and the other side border smoothly connect.

[0060] Given an incline angle  $\theta_c$  of the end bent sections **44a** and **44b** respectively formed at the ends of the two linear sections **42a** and **42b** with respect to the aligning treatment directions **1a** and **2a**,  $\theta_c$  is set to:

[0061]  $20^\circ < \theta_c < 40^\circ$

[0062] Then, given a length  $L_c$  of the end bent sections **44a** and **44b**, the length  $L_c$  with respect to the length  $L_a$  of the linear sections **42a** and **42b** of the bent electrode section **41** is set to a value such that:

[0063]  $L_a < nL_c$  ( $n$ : 3 to 5)

[0064]  $10L_c > L_a > 4L_c$ .

[0065] That is, the end bent sections **44a** and **44b** of both ends of the bent electrode **41** are formed at substantially the same incline angle and length as the bent sections **43a** and **43b** connecting the two linear sections **42a** and **42b**.

[0066] The incline angle  $\theta_a$  of the two linear sections **42a** and **42b** of the plurality of bent electrodes **41** of the pixel electrode **4** with respect to the aligning treatment directions **1a** and **2a** is preferably set to  $5^\circ \sim 15^\circ$  ( $10^\circ \pm 5^\circ$ ), more preferably to  $8^\circ \sim 12^\circ$  ( $10^\circ \pm 2^\circ$ ). Further, the incline angles  $\theta_b$  and  $\theta_c$  of the bent sections **43a** and **43b** connecting the two linear sections **42a** and **42b** and the end bent sections **44a** and **44b** with respect to the aligning treatment directions **1a** and **2a** are preferably set to  $25^\circ \sim 35^\circ$  ( $30^\circ \pm 5^\circ$ ), more preferably to  $30^\circ \pm 2^\circ$ .

[0067] Of the plurality of bent electrodes **41** of the pixel electrode **4**, the linear section **42b** of the side connected to the TFT **6** is formed to a length this is shorter than the linear section **42b** of the other bent electrode **41**, away from the region corresponding to a source electrode **11** of the TFT **6**.

[0068] The liquid crystal layer **3** comprises nematic liquid crystal having positive dielectric anisotropy and, in the initial state when an electric field is not generated between the pixel electrode **4** and the opposing electrode **5**, the liquid crystal molecule **3a** of this liquid crystal layer **3** is aligned substantially parallel with the surfaces of the substrates **1** and **2**, with its long axis in the aligning treatment directions **1a** and **2a**.

[0069] FIG. 5 shows an enlarged view of a cross-section cut along line V-V of FIG. 3. The liquid crystal molecule **3a**, as shown in FIG. 3 and FIG. 5, is aligned with its long axis in alignment with the aligning treatment directions **1a** and **2a**. The liquid crystal molecule **3a** is aligned with the liquid crystal molecule end that is on the side toward the aligning treatment directions **1a** and **2a** formed on the respective inner surface of each substrate pretilted away from the respective substrate. That is, the liquid crystal molecule **3a** is aligned substantially parallel to the surfaces of the substrates **1** and **2**.

[0070] Further, a transparent anti-static conductive film **21** of a single film shape for blocking static electricity from outside is provided between the front substrate **1** and a front side polarizing plate **19** arranged on the outer surface thereof, across the entire surface of the front substrate **1**.

[0071] This liquid crystal display device generates an electric field parallel to the substrates that changes the orientation of the long axis of the liquid crystal molecule **3a** between the plurality bent electrodes **41** of the pixel electrode **4** and the opposing electrode **5** to substantially parallel with the surfaces of the substrate **1** and **2** by applying drive voltage corresponding to display data between the pixel electrode **4** and the opposing electrode **5** of the plurality of pixels **100**. Then, the liquid crystal display device controls on a surface substantially parallel with the surfaces of the substrates **1** and **2** the orientation of the long axis of the liquid crystal molecule **3a** of the plurality of pixels **100** by this electric field parallel to the substrates, and displays an image.

[0072] The drive voltage applied between the pixel electrode **4** and the opposing electrode **5** is controlled within the range of a minimum value of substantially 0 at which the electric field parallel to the substrates is not generated, to a maximum value at which an electric field parallel to the substrates is generated at an intensity that aligns the liquid crystal molecule **3a** of the pixel region where the pixel electrode **4** is arranged so that its long axis is substantially in the direction of  $45^\circ$  with respect to the aligning treatment directions **1a** and **2a**.

[0073] The liquid crystal display device of this example is, for example, a non-electrolytic black display type (hereinafter "normally black type") in which the transparent axis of either the front side polarizing plate **19** or the back side polarizing plate **20** is substantially parallel with or substantially orthogonal to the aligning treatment directions **1a** and **2a**, and the transparent axis of the other polarizing plate is substantially orthogonal to the one polarizing plate. Then, the display of the pixel **100** turns black in non-electrolytic mode in which an electric field parallel to the substrates is not generated between the pixel electrode **4** and the opposing electrode **5**, that is, when the liquid crystal molecule **3a** is aligned so that its long axis is in alignment with the aligning treatment directions **1a** and **2a**, as shown in FIG. 3. Further,

the display of the pixel 100 becomes brightest when an electric field parallel to the substrates of an intensity that aligns the liquid crystal molecule 3a so that its long axis is substantially in the direction of 45° with respect to the aligning treatment directions 1a and 2a is generated between the pixel electrode 4 and the opposing electrode 5.

[0074] FIG. 6 shows the orientation of the long axis of the liquid crystal molecule 3a of each section in a single pixel 100 when an electric field parallel to the substrates of an intensity that aligns the liquid crystal molecule 3a so that its long axis is substantially in the direction of 45° with respect to the aligning treatment directions 1a and 2a is generated between the pixel electrode 4 and the opposing electrode 5. FIG. 7 shows an enlarged view of a cross-section cut along line VII-VII of FIG. 6. FIG. 8 shows an enlarged view of a cross-section cut along line VIII-VIII of FIG. 6.

[0075] As shown in FIG. 6 and FIG. 8, a transversal electric field E is generated between the section adjacent to the bent electrode 41 of the opposing electrode 5 and one side border (fringe) and the other side border of the plurality of bent electrodes 41 of the pixel electrode 4.

[0076] This transversal electric field E is an electric field of a direction orthogonal to the side border of the plurality of bent electrodes 41 of the pixel electrode 4. The orientation of the liquid crystal molecule 3a is changed by the generation of the transversal electric field E to a direction in which the angle of its long axis with respect to the orientation of the transversal electric field E decreases.

[0077] Then, this liquid crystal display device is formed into a shape in which the plurality of bent electrodes 41 of the pixel electrode 4 is substantially bent into a "<" shape, and the two linear sections 42a and 42b respectively intersect the aligning treatment directions 1a and 2a of the inner surfaces of the pair of substrates 1 and 2 at substantially the same angle. As a result, the liquid crystal display device, as shown in FIG. 6, can set different orientations for the transversal electric field E generated between one linear section 42a of the plurality of bent electrodes 41 of the pixel electrode 4 and the opposing electrode 5, and the transversal electric field E generated between the other linear section 42b of the bent electrode 41 and the opposing electrode 5. This enables formation of a region where the liquid crystal molecule 3a is aligned in two different orientations within each pixel 100, thereby achieving a display having a wide view without display view dependability.

[0078] Additionally, this liquid crystal display device provides in the section connecting the two linear sections 42a and 42b of the plurality of bent electrodes 41 of the pixel electrode 4 a bent section 43a wherein the side connected to one linear section 42a bends in a direction in which the incline angle with respect to the aligning treatment directions 1a and 2a increases with respect to the one linear section 42a, and a bent section 43b wherein the side connected to the other linear section 42b bends in a direction in which the incline angle with respect to the aligning treatment directions 1a and 2a increases with respect to the other linear section 42b, and is formed into a shape in which these bent sections 43a and 43b connect at a connection section. As a result, even when a strong transversal electric field E that aligns the liquid crystal molecule 3a so that its long axis is substantially at or near the direction of 45° with respect to the aligning treatment directions 1a and 2a is generated between the pixel electrode 4 and

the opposing electrode 5, the liquid crystal molecule 3a never tilts at an incline opposite the incline of the pretilt resulting from the aligning treatment.

[0079] That is, as shown in the comparative example of FIG. 9, with an electrode of a "<" shape, the transversal electric field E generated between one side border of the bent electrode 41 of the pixel electrode 4 and the opposing electrode 5 and the transversal electric field E generated between the other side border of the other linear section 42b of the bent electrode 41 and the opposing electrode 5 have mutually opposite orientations. Then, the plurality of bent electrodes 41 of the pixel electrode 4 is formed into a shape that bends substantially into a "<" shape with the two linear sections 42a and 42b respectively intersecting at opposite incline angles with respect to the aligning treatment directions 1a and 2a.

[0080] The transversal electric field E generated between one side border of one linear section 42a of the bent electrode 41 of the pixel electrode 4 and the opposing electrode 5, and the transversal electric field E generated between the other side border of the other linear section 42b of the bent electrode 41 and the opposing electrode 5 are each an electric field of an orientation that tilts the liquid crystal molecule 3a, which had changed orientation due to the transversal electric field E, to an incline opposite the incline of the pretilt resulting from the aligning treatment of the substrate inner surfaces (hereinafter opposite electric field).

[0081] With this arrangement, when a strong transversal electric field E is generated between the pixel electrode 4 and the opposing electrode 5, the force that tilts the liquid crystal molecule 3a as a result of the transversal electric field E acting on the liquid crystal molecule 3a becomes stronger than the force (tilt orientation force of aligning films 17 and 18) that pretilts the liquid crystal molecule 3a as a result of the aligning treatment of the substrate inner surfaces. In consequence, the liquid crystal molecule 3a of the opposite electric field generation region S1 along one side border of one linear section 42a of the bent electrode 41, and the liquid crystal molecule 3a of the opposite electric field generation region S2 along the other side border of the other linear section 42b tilt at an incline opposite the incline of the pretilt resulting from the aligning treatment of the substrate inner surfaces.

[0082] That is, when the transversal electric field E is a weak electric field that changes the long axis orientation of the liquid crystal molecule 3a at a small angle with respect to the aligning treatment directions 1a and 2a, the liquid crystal molecule 3a changes in orientation when tilted in the incline direction of the pretilt resulting from the aligning treatment of the substrate inner surfaces, even in the opposite electric field generation area, due to the pretilt orientation force of the substrate inner surfaces. However, when the transversal electric field E is a strong electric field that changes the orientation of the long axis of the liquid crystal molecule 3a at a large angle with respect to the aligning treatment directions 1a and 2a, the force resulting from the electric field parallel to the substrates acts more strongly on the liquid crystal molecule 3a than the pretilt orientation force of the substrate inner surfaces. As a result, the liquid crystal molecule 3a of the opposite electric field generation regions S1 and S2 tilts at an incline opposite the incline of the pretilt resulting from the aligning treatment.

[0083] The opposite tilt of the liquid crystal molecule 3a resulting from this transversal electric field E (the tilt of the incline opposite the pretilt incline resulting from the aligning treatment of the substrate inner surfaces) appears from the

section corresponding to the bending point of the “V” shape. Then, as the electric field parallel to the substrates E becomes larger, the opposite tilt region increases, becoming longer along the two linear sections **42a** and **42b**.

[0084] FIG. 9 shows the orientation of the long axis of the liquid crystal molecule **3a** of each section within one pixel **100** when an electric field parallel to the substrates of an intensity that aligns the liquid crystal molecule **3a** near the linear sections **42a** and **42b** of the bent electrode **41** of the pixel electrode **4** so that its long axis is substantially in the direction of  $45^\circ$  with respect to the aligning treatment directions **1a** and **2a** is generated between the pixel electrode **4** and the opposing electrode **5** in a comparison example wherein the plurality of bent electrodes **41** of the pixel electrode **4** is formed into a “<” shape where the two linear sections **42a** and **42b** directly connect. FIG. 10 shows a cross-section cut along line X-X of FIG. 9, and FIG. 11 shows a cross-section cut along line XI-XI of FIG. 9.

[0085] As shown in FIG. 9 to FIG. 11, in the comparative example in which the plurality of electrode sections **41** of the pixel electrode **4** is formed into a “<” shape where the two linear sections **42a** and **42b** directly connect, when a strong electric field parallel to the substrates E is generated between the pixel electrode **4** and the opposing electrode **5**, the liquid crystal molecule **3a** of the region S1 along the right side border of the linear section **42a** of the upper side and the liquid crystal molecule **3a** of the region S2 along the left side border of the linear section **42b** of the upper side in FIG. 9 tilt at an incline opposite (an incline in the direction away from the back substrate **2** toward the upward left diagonal direction) the incline of the pretilt (the incline in the direction away from the back substrate **2** toward the downward right diagonal direction when viewed from the molecular end side that appears in bold in the figure) resulting from the aligning treatment of the substrate inner surfaces.

[0086] As a result, in this comparative example, when a strong electric field E is generated between the pixel electrode **4** and the opposing electrode **5**, the regions S1 and S2 where the liquid crystal molecule **3a** has been set to an opposite tilt (a tilt of an incline opposite the incline of the pretilt) and another region where an opposite tilt of the liquid crystal molecule **3a** does not occur are created. In this comparative example, display non-uniformity occurs due to the difference in the tilt directions of the liquid crystal molecule **3a** of these regions.

[0087] Contrary to this comparative example, the liquid crystal display device of the above-described example is formed into a shape in which the side connecting the section connecting the two linear sections **42a** and **42b** of the plurality of bent electrodes **41** of the pixel electrode **4** to one linear section **42a** bends in a direction in which the incline angle with respect to the aligning treatment directions **1a** and **2a** increases with respect to the one linear section **42a**. Further, the liquid crystal display device is formed so that the side connecting to the other linear section **42b** bends in a direction in which the incline angle with respect to the aligning treatment directions **1a** and **2a** increases with respect to the other linear section **42b**. As a result, of the electric fields E parallel to the substrates between the pixel electrode **4** and the opposing electrode **5**, the transversal electric field E generated between one side border and the other side border of the bent sections **43a** and **43b** of the plurality of bent electrodes **41** of the pixel electrode **4** and the opposing electrode **5** (the electric fields in the direction orthogonal to the side borders of the

bent sections **43a** and **43b**) has an intersecting angle with respect to the aligning treatment directions **1a** and **2a** that is smaller than that of the electric E field parallel to the substrates generated between one side border and the other side border of the linear sections **42a** and **42b** of the bent electrode **41** and the opposing electrode **5**, as shown in FIG. 6.

[0088] In this manner, the changed angle  $\phi_b$  of the long axis orientation with respect to the aligning treatment directions **1a** and **2b** of the liquid crystal molecule **3a** of the regions along one side border and the other side border of the bent sections **43a** and **43b** resulting from the transversal electric field E is smaller than the changed angle  $\phi_a$  of the long axis orientation with respect to the aligning treatment directions **1a** and **2a** of the liquid crystal molecule **3a** of the regions along one side border and the other side border of the linear sections **42a** and **42b**. For this reason, the orientation restraining force of the alignment film and the neighboring intermolecular force aligned by this orientation restraining force act on the liquid crystal molecule **3a** of the regions along one side border and the other side border of the bent sections **43a** and **43b** more intensely than the force resulting from the transversal electric field E. As a result, any change in the tilt angle of the liquid crystal molecule resulting from the transversal electric field E is suppressed.

[0089] Further, because the discontinuity of the orientation of the liquid crystal molecule **3a** of the region corresponding to the linear section **42b** of the bottom side with the linear section **42a** of the upper side decreases in the figure of the bent electrode **41** since the bent sections **43a** and **43b** are connected by a continuous curve, the change in the tilt angle of the liquid crystal molecule is suppressed.

[0090] As a result, even when a strong transversal electric field E that aligns the liquid crystal molecule **3a** of the regions along the linear sections **42a** and **42b** of the bent electrode **41** of the pixel electrode **4** so that its long axis is substantially at or near the direction of  $45^\circ$  with respect to the aligning treatment directions **1a** and **2a** is generated between the pixel electrode **4** and the opposing electrode **5**, the long axis orientation is changed in a state where the liquid crystal molecule is tilted in the incline direction of the pretilt resulting from the aligning treatment, without the tilt of the liquid crystal molecule near the bent section reversing.

[0091] In consequence, a starting point for reversing the tilt of the liquid crystal molecule **3a** of the regions along one side border and the other side border of the linear sections **42a** and **42b** of the bent electrode **41** never occurs in the section corresponding to the bending point of the bent electrode **41** of a “<” shape, as in the comparative example shown in FIG. 9 to FIG. 11.

[0092] Then, the connecting sections of the two bent sections **43a** and **43b**, which connect the two linear sections **42a** and **42b**, and the linear sections **42a** and **42b** are each formed into a circular arc shape where one side border and the other side border smoothly connect. For this reason, the liquid crystal molecule **3a** of the respective regions corresponding to the linear sections **42a** and **42b** achieves a substantially continuous aligned state in the bent sections **43a** and **43b**.

[0093] In this manner, even when a strong transversal electric field E that aligns the liquid crystal molecule **3a** of the regions along the linear sections **42a** and **42b** of the bent electrode **41** of the pixel electrode **4** so that its long axis is substantially at or near the direction of  $45^\circ$  with respect to the aligning treatment directions **1a** and **2a** is generated between the pixel electrode **4** and the opposing electrode **5**, as shown

in FIG. 6 to FIG. 8, the liquid crystal display device achieves good display quality without orientation non-uniformity in the regions corresponding to the plurality of bent electrodes 41 of the pixel electrode 4.

[0094] Furthermore, in this liquid crystal display device, end bent sections 44a and 44b respectively connected to the linear sections 42a and 42b and bent in a direction in which the incline angle with respect to the aligning treatment directions 1a and 2a increases with respect to the linear sections 42a and 42b are formed at the respective ends of the two linear sections 42a and 42b of the plurality of bent electrodes 41 of the pixel electrode 4. As a result, a transversal electric field E of an orientation having a smaller intersecting angle with respect to the aligning treatment directions 1a and 2a than the transversal electric field E generated between one side border and the other side border of the linear sections 42a and 42b of the bent electrode 41 and the opposing electrode 5 is generated between one side border of the end bent sections 44a and 44b and the opposing electrode 5 as well.

[0095] That is, a changed angle  $\phi_c$  of the long axis orientation with respect to the aligning treatment directions 1a and 2a of the liquid crystal molecule 3a of the regions along one side border and the other side border of the end bent sections 44a and 44b resulting from the transversal electric field E is smaller than the changed angle  $\phi_a$  of the long axis orientation with respect to the aligning treatment directions 1a and 2a of the liquid crystal molecule 3a of the regions along one side border and the other side border of the linear sections 42a and 42b. With such an arrangement, an opposite tilt resulting from the transversal electric field E never occurs with the liquid crystal molecule 3a of either region along one side border or the other side border of the end bent sections 44a and 44b, thereby enabling the liquid crystal display device to change the long axis orientation at the incline of the pretilt resulting from the aligning treatment. Thus, the liquid crystal display device more effectively eliminates the opposite tilt of the liquid crystal molecule 3a resulting from the transversal electric field E.

[0096] Then, given an incline angle  $\theta_a$  of the two linear sections 42a and 42b of the plurality of bent electrodes 41 of the pixel electrode 4 with respect to the aligning treatment directions 1a and 2a, and an incline angle  $\theta_b$  of the two bent sections 43a and 43b connecting the two linear sections with respect to the aligning treatment directions 1a and 2a, this liquid crystal display device defines  $\theta_a$  and  $\theta_b$  as follows:

[0097]  $0^\circ < \theta_a < 20^\circ$

[0098]  $20^\circ < \theta_b < 40^\circ$

[0099] As a result, the liquid crystal display device eliminates more thoroughly the opposite tilt of the liquid crystal molecule 3a resulting from the transversal electric field E.

[0100] Further, given a length La of the two linear sections 42a and 42b of the plurality of bent electrodes 41 of the pixel electrode 4, and a length Lb of the two bent sections 43a and 43b connecting the two linear sections 42a and 42b, this liquid crystal display device defines La and Lb as follows:

[0101]  $La > nLb$  (n: 3 to 5)

[0102]  $10Lb > La > 4Lb$ .

[0103] As a result, the liquid crystal display device amply exhibits an opposite tilt prevention effect on the liquid crystal molecule 3a resulting from the bent section, and substantially diminishes the effect on the display of the region corresponding to the bent section.

[0104] Furthermore, this liquid crystal display device defines the incline angle  $\theta_c$  of the end bent sections 44a and

44b respectively formed at the ends of the two linear sections 42a and 42b of the plurality of bent electrodes 41 of the pixel electrode 4 with respect to the aligning treatment directions 1a and 2a as:

[0105]  $20^\circ < \theta_c < 40^\circ$

[0106] As a result, this liquid crystal display device eliminates more thoroughly the opposite tilt of the liquid crystal molecule 3a resulting from the transversal electric field E.

[0107] Further, this liquid crystal display device defines the length Lc of the end bent sections 44a and 44b with respect to the length La of the linear sections 42a and 42b of the bent electrode 41 as a value such that:

[0108]  $La > nLc$  (n: 3 to 5)

[0109]  $10Lc > La > 4Lc$ .

[0110] As a result, the liquid crystal display device amply exhibits an opposite tilt prevention effect on the liquid crystal molecule 3a resulting from the end bent sections 44a and 44b and substantially diminishes the effect on the display of the region corresponding to the end bent sections 44a and 44b.

[0111] In this liquid crystal display device, the incline angle  $\theta_a$  of the two linear sections 42a and 42b of the plurality of bent electrodes 41 of the pixel electrode 4 with respect to the aligning treatment directions 1a and 2a is preferably set to  $5^\circ \sim 15^\circ$  ( $10^\circ \pm 5^\circ$ ) more preferably to  $10^\circ \pm 2^\circ$ . Further, the incline angles  $\theta_b$  and  $\theta_c$  of the bent sections 43a and 43b, which connect the two linear sections 42a and 42b, and of the end bent sections 44a and 44b with respect to the aligning treatment directions 1a and 2a are preferably set to  $25^\circ \sim 35^\circ$  ( $30^\circ \pm 5^\circ$ ), more preferably to  $28^\circ \sim 32^\circ$  ( $30^\circ \pm 2^\circ$ ). In this manner, the liquid crystal display device eliminates more thoroughly the opposite tilt of the liquid crystal molecule 3a resulting from the transversal electric field E.

[0112] While the plurality of bent electrodes 41 of the pixel electrode 4 is commonly connected at both respective ends in the above-described example, the plurality of bent electrodes 41 may be commonly connected at one end (the end on the side connected to the TFT 6).

[0113] Further, while the opposing electrode 5 is formed in a shape corresponding to the entire area of the pixel 100 in the above-described example, the opposing electrode 5 may correspond to at least the area between the plurality of bent electrodes 41 and 41 of the pixel electrode 4.

[0114] Furthermore, for the first and second electrodes provided in mutual isolation on the inner surface of the back substrate 2, the liquid crystal display device of the above-described example employs a plurality of pixel electrodes 4 aligned in a matrix shape as the first electrode on the side of the liquid crystal layer 3, and the opposing electrode 5 as the second electrode farther toward the side of the back substrate 2. However, the liquid crystal display device may conversely employ an opposing electrode as the first electrode on the side of the liquid crystal layer 3, and a plurality of pixel electrodes formed into a matrix shape as the second electrode farther toward the side of the back substrate 2. In this case, the liquid crystal display device may form a plurality of bent electrodes on the opposing electrode, and form the pixel electrode into a shape that corresponds to the entire pixel area or that corresponds to the area between the plurality of bent electrodes of the opposing electrode.

[0115] Further, while the first and second electrodes are provided on the inner surface of the back substrate 2 in the above-described example, the first and second electrodes may be provided on the inner surface of the front substrate 1.

**[0116]** As described above, the liquid crystal display device of the present invention comprises a pair of substrates arranged opposite each other at a predetermined gap having been subjected to an aligning treatment in mutually parallel directions on each of the mutually opposed inner surfaces; a liquid crystal layer interposed in the gap between the pair of substrates and arranged substantially in parallel with the surfaces of the substrates, with the long axis of the liquid crystal molecule aligned in the direction of the aligning treatment; a plurality of first electrodes that are provided on one of the mutually opposed inner surfaces of the pair of substrates and comprise, in each predetermined region for forming a single pixel, one linear section and another linear section that extend in directions that intersect the aligning treatment direction at different angles, a bent section that is provided at each end where the one linear section and the other linear section adjacent to each other and that extends in a direction that intersects the aligning treatment direction at an angle greater than the respective intersecting angles of the one linear section and the other linear section and the aligning treatment direction with respect to the aligning treatment direction, and a connection section that connects these bent sections; and a second electrode that generates with the first electrode a transversal electric field for changing the orientation of the long axis of the liquid crystal molecule within a plane substantially parallel to the surfaces of the substrates.

**[0117]** In this liquid crystal display device, the first electrode preferably comprises a plurality of linear sections long and narrow in shape that are formed in parallel at a distance from each other, and connects to each pixel on at least one end of the linear section. Further, preferably a plurality of slits for forming the plurality of linear sections is formed on a transparent conductive film having an area corresponding to a predetermined region for forming a single pixel, and the first electrode is formed from a transparent conductive film other than the transparent conductive film removed as a result of the plurality of slits. Furthermore, preferably the first electrode forms two regions for aligning the long axes of the liquid crystal molecules in two different orientations, a first orientation and a second orientation, when an electric field is applied between the first electrode and the second electrode, and one linear section of the first electrode is formed in one of these two regions, and the other linear section of the first electrode is formed in the other of the two regions. Then, the side border of the connection section of the first electrode is preferably formed into a continuous curved surface.

**[0118]** Further, in this liquid crystal display device, the second electrode is preferably arranged in isolation from the first electrode, between the first electrode of the one substrate and the one substrate.

**[0119]** Furthermore, in the liquid crystal display device, given an incline angle  $\theta_a$  of the one linear section and the other linear section of the first electrode with respect to the aligning treatment directions, and an incline angle  $\theta_b$  of each of the bent sections provided at the ends of two adjacent linear sections with respect to the aligning treatment directions, the incline angle  $\theta_a$  of the linear section and the incline angle  $\theta_b$  of the bent section are preferably set to  $0^\circ < \theta_a < 20^\circ$  and  $20^\circ < \theta_b < 40^\circ$ . Further, given a length  $L_a$  of one linear section and the other linear section of the first electrode, and a length  $L_b$  of the bent section, the two lengths  $L_a$  and  $L_b$  are preferably set to  $L_a > n L_b$  ( $n$ : 3 to 5) and  $10 L_b > L_a > 4 L_b$ .

**[0120]** Then, in the liquid crystal display device, preferably the first electrode forms an end bent section that is provided

on at least the end of either the one linear section or the other linear section, in connection to the linear section, on the side opposite the side where the ends adjacent to each other, and that bends in a direction in which the incline angle with respect to the aligning treatment directions increases with respect to the linear section. In this case, given an incline angle  $\theta_c$  of the end bent section with respect to the aligning treatment directions, the incline angle  $\theta_c$  is preferably set to  $20^\circ < \theta_c < 40^\circ$ . Further, given a length  $L_a$  of the linear section and a length  $L_c$  of the end bent section, the length  $L_c$  of the end bent section is preferably set to  $L_a > n L_c$  ( $n$ : 3 to 5) and  $10 L_c > L_a > 4 L_c$ .

**[0121]** Various examples and changes may be made thereto without departing from the broad spirit and scope of the invention. The above-described example is intended to illustrate the present invention, not to limit the scope of the present invention. The scope of the present invention is shown by the attached claims rather than the example. Various modifications made within the meaning of an equivalent of the claims of the invention and within the claims are to be regarded to be in the scope of the present invention.

**[0122]** This application is based on Japanese Patent Application No. 2006-263223 filed on Sep. 27, 2006 and including specification, claims, drawings and summary. The disclosure of the above Japanese Patent Application is incorporated herein by reference in its entirety.

What is claimed is:

1. A liquid crystal display device comprising a liquid crystal layer and a pair of opposed substrates, each of the opposed substrates having an aligning-treated surface that has been subjected to an aligning treatment, the opposed substrates being arranged so that their respective aligning-treated surfaces are opposed to each other with the liquid crystal layer therebetween;

wherein a first substrate of the pair of opposed substrates comprises:

a first electrode having a slit comprising a plurality of opening regions that are formed so as to be serially continuous, wherein the opening regions extend in directions different from each other and different from directions of the aligning treatment; and

a second electrode that covers the slit via an insulating layer;

wherein the slit comprises a plurality of pairs of the opening regions, and each of the pairs of the opening regions comprises two opening regions that extend at respective angles that are symmetrical to each other with respect to a direction orthogonal to the directions of the aligning treatment.

2. The liquid crystal display device according to claim 1, wherein outside dimensions of the first electrode are larger than outside dimensions of the second electrode.

3. The liquid crystal display device according to claim 1, wherein the slit is formed so that opening regions whose degree of parallelism to the directions of the aligning treatment is higher than the degree of parallelism of other opening regions to the directions of the aligning treatment, are sandwiched by the other opening regions.

4. The liquid crystal display device according to claim 1, wherein the slit is formed so that opening regions whose degree of parallelism to the directions of the aligning treatment is lower than the degree of parallelism of other opening regions to the directions of the aligning treatment, are sandwiched by the other opening regions.

5. The liquid crystal display device according to claim 1, wherein the first electrode is formed of a transparent conductive film, and the transparent conductive film surrounds the slit.

6. The liquid crystal display device according to claim 1, wherein a plurality of the slits are formed for each display pixel of the liquid crystal display device.

7. The liquid crystal display device according to claim 1, wherein the liquid crystal layer is aligned so that long axes of liquid crystal molecules become parallel with the aligning-treated surfaces of the opposed substrates.

8. The liquid crystal display device according to claim 1, wherein the liquid crystal layer comprises liquid crystal molecules having positive dielectric anisotropy.

9. The liquid crystal display device according to claim 1, wherein the first electrode is positioned closer to the liquid crystal layer than the second electrode.

10. A liquid crystal display device comprising a liquid crystal layer and a pair of opposed substrates, each of the opposed substrates having an aligning-treated surface that has been subjected to an aligning treatment, the opposed substrates being arranged so that their respective aligning-treated surfaces are opposed to each other with the liquid crystal layer therebetween;

wherein a first substrate of the pair of opposed substrates comprises:

a first electrode having a slit comprising a plurality of opening regions that are formed so as to be serially continuous, wherein the opening regions extend in directions different from each other and different from directions of the aligning treatment; and

a second electrode that covers the slit via an insulating layer;

wherein the slit comprises a plurality of opening regions extending at respective different angles to a first diagonal direction of a display pixel and a plurality of opening regions extending at respective different angles to a second diagonal direction of the display pixel.

11. The liquid crystal display device according to claim 10, wherein the slit is formed so that opening regions whose degree of parallelism to the directions of the aligning treatment is higher than the degree of parallelism of other opening regions to the directions of the aligning treatment, are sandwiched by the other opening regions.

12. The liquid crystal display device according to claim 10, wherein the first substrate of the pair of opposed substrates further comprises a signal line which extends in a direction parallel to the directions of the aligning treatment and a scan line which extends in a direction orthogonal to the directions of the aligning treatment.

13. The liquid crystal display device according to claim 12, wherein the first electrode is a pixel electrode connected to the signal line and the scan line via a thin film transistor, and the second electrode is a common electrode which is set to an equal potential between display pixels.

14. The liquid crystal display device according to claim 10, wherein a plurality of the slits are formed for each display pixel of the liquid crystal display device.

15. A liquid crystal display device comprising a liquid crystal layer and a pair of opposed substrates, each of the opposed substrates having an aligning-treated surface that has been subjected to an aligning treatment, the opposed

substrates being arranged so that their respective aligning-treated surfaces are opposed to each other with the liquid crystal layer therebetween;

wherein a first substrate of the pair of opposed substrates comprises:

a first electrode having a slit comprising a plurality of opening regions that are formed so as to be serially continuous, wherein the opening regions extend in directions different from each other and different from directions of the aligning treatment; and

a second electrode that covers the slit via an insulating layer;

wherein the slit comprises a plurality of pairs of the opening regions, and each of the pairs of the opening regions comprises two opening regions that extend at respective angles that are symmetrical to each other with respect to a direction orthogonal to an extending direction of a scan line; and

wherein the slit is formed so that opening regions whose degree of parallelism to an extending direction of a signal line is higher than the degree of parallelism of other opening regions to the extending direction of the signal line, are sandwiched by the other opening regions.

16. A liquid crystal display device comprising a liquid crystal layer and a pair of opposed substrates, each of the opposed substrates having an aligning-treated surface that has been subjected to an aligning treatment, the opposed substrates being arranged so that their respective aligning-treated surfaces are opposed to each other with the liquid crystal layer therebetween;

wherein a first substrate of the pair of opposed substrates comprises:

a first electrode having a slit comprising a plurality of opening regions that are formed so as to be serially continuous, wherein the opening regions extend in directions different from each other and different from directions of the aligning treatment; and

a second electrode that covers the slit via an insulating layer;

wherein the slit comprises a plurality of pairs of the opening regions, and each of the pairs of the opening regions comprises two opening regions that extend at respective angles that are symmetrical to each other with respect to a direction orthogonal to an extending direction of a scan line; and

wherein the slit is formed so that opening regions whose degree of parallelism to an extending direction of a signal line is lower than the degree of parallelism of other opening regions to the extending direction of the signal line, are sandwiched by the other opening regions.

17. A liquid crystal display device comprising a liquid crystal layer and a pair of opposed substrates, each of the opposed substrates having an aligning-treated surface that has been subjected to an aligning treatment, the opposed substrates being arranged so that their respective aligning-treated surfaces are opposed to each other with the liquid crystal layer therebetween;

wherein a first substrate of the pair of opposed substrates comprises:

a first electrode having a slit comprising a plurality of opening regions that are formed so as to be serially continuous, wherein the opening regions extend in

directions different from each other and different from directions of the aligning treatment; and  
a second electrode that covers the slit via an insulating layer;

wherein outside dimensions of the first electrode are larger than outside dimensions of the second electrode.

**18.** The liquid crystal display device according to claim 17, wherein one said first electrode and one said second electrode are disposed for each pixel of the liquid crystal display device; and

wherein the second electrodes of adjacent pixels are electrically connected to each other by a common connection section.

**19.** The liquid crystal display device according to claim 17, wherein the first electrode is connected to a thin film transistor, and the second electrode is arranged so as to avoid a position where the thin film transistor is arranged.

**20.** A liquid crystal display device comprising a liquid crystal layer and a pair of opposed substrates, each of the opposed substrates having an aligning-treated surface that has been subjected to an aligning treatment, the opposed substrates being arranged so that their respective aligning-treated surfaces are opposed to each other with the liquid crystal layer therebetween;

wherein a first substrate of the pair of opposed substrates comprises:

a first electrode having a slit comprising a plurality of opening regions that are formed so as to be serially continuous, wherein the opening regions extend in directions different from each other and different from directions of the aligning treatment; and

a second electrode that covers the slit via an insulating layer;

wherein outside dimensions of the second electrode are smaller than outside dimensions of the first electrode.

\* \* \* \* \*

专利名称(译)	面内切换型液晶显示装置		
公开(公告)号	<a href="#">US20100157222A1</a>	公开(公告)日	2010-06-24
申请号	US12/716864	申请日	2010-03-03
[标]申请(专利权)人(译)	卡西欧计算机株式会社		
申请(专利权)人(译)	CASIO COMPUTER CO., LTD.		
当前申请(专利权)人(译)	统一创新科技有限责任公司		
[标]发明人	ARAI NORIHIRO KOBAYASHI KUNPEI NISHINO TOSHIHARU		
发明人	ARAI, NORIHIRO KOBAYASHI, KUNPEI NISHINO, TOSHIHARU		
IPC分类号	G02F1/1337 G02F1/1343		
CPC分类号	G02F1/134363 G02F1/1337		
优先权	2006263223 2006-09-27 JP		
其他公开文献	US8436972		
外部链接	<a href="#">Espacenet</a> <a href="#">USPTO</a>		

摘要(译)

一种液晶显示装置，包括在相互平行但相反的方向上进行对准处理的一对基板，插入在所述一对基板之间的液晶层，弯曲成“<”形的第一电极和通过其形成的第二电极。具有第一电极的绝缘膜。第一电极包括一个线性部分和另一个线性部分，其在与取向处理方向以不同角度相交的方向上延伸，弯曲部分设置在每个端部处，其中一个线性部分和另一个线性部分彼此相邻并且在与取向处理方向交叉的方向上延伸的角度大于一个线性部分和另一个线性部分的交叉角度以及取向处理方向相对于取向处理方向的每个角度。

