



(19) **United States**

(12) **Patent Application Publication**
Choi

(10) **Pub. No.: US 2007/0070281 A1**
(43) **Pub. Date: Mar. 29, 2007**

(54) **LIQUID CRYSTAL DISPLAY DEVICE AND METHOD FOR MANUFACTURING THE SAME**

(52) **U.S. Cl. 349/141; 349/156**

(75) **Inventor: Kee Seok Choi, Paju-si (KR)**

(57) **ABSTRACT**

Correspondence Address:
BRINKS HOFER GILSON & LIONE
P.O. BOX 10395
CHICAGO, IL 60610 (US)

(73) **Assignee: LG PHILIPS LCD CO., LTD.**

A liquid crystal display device comprises first and second substrates that face each other, first and second lines formed on the first substrate in first and second directions that cross each other, respectively. The liquid crystal display device further comprises a protrusion formed at a predetermined portion on the first line, a first column spacer formed on the second substrate so as to correspond to the protrusion and having a corresponding surface with respect to the protrusion. The corresponding surface is wider than the protrusion. The liquid crystal display device also comprises a compensation pattern formed at another predetermined portion on the first line where the protrusion is not formed, and having a lower height than the protrusion, a second column spacer corresponding to the compensation pattern. The liquid crystal display device then comprises a liquid crystal layer between the first and second substrates. A method for manufacturing the LCD device is also disclosed.

(21) **Appl. No.: 11/479,428**

(22) **Filed: Jun. 29, 2006**

(30) **Foreign Application Priority Data**

Sep. 23, 2005 (KR) P2005-0088778

Publication Classification

(51) **Int. Cl.**
G02F 1/1343 (2006.01)
G02F 1/1339 (2006.01)

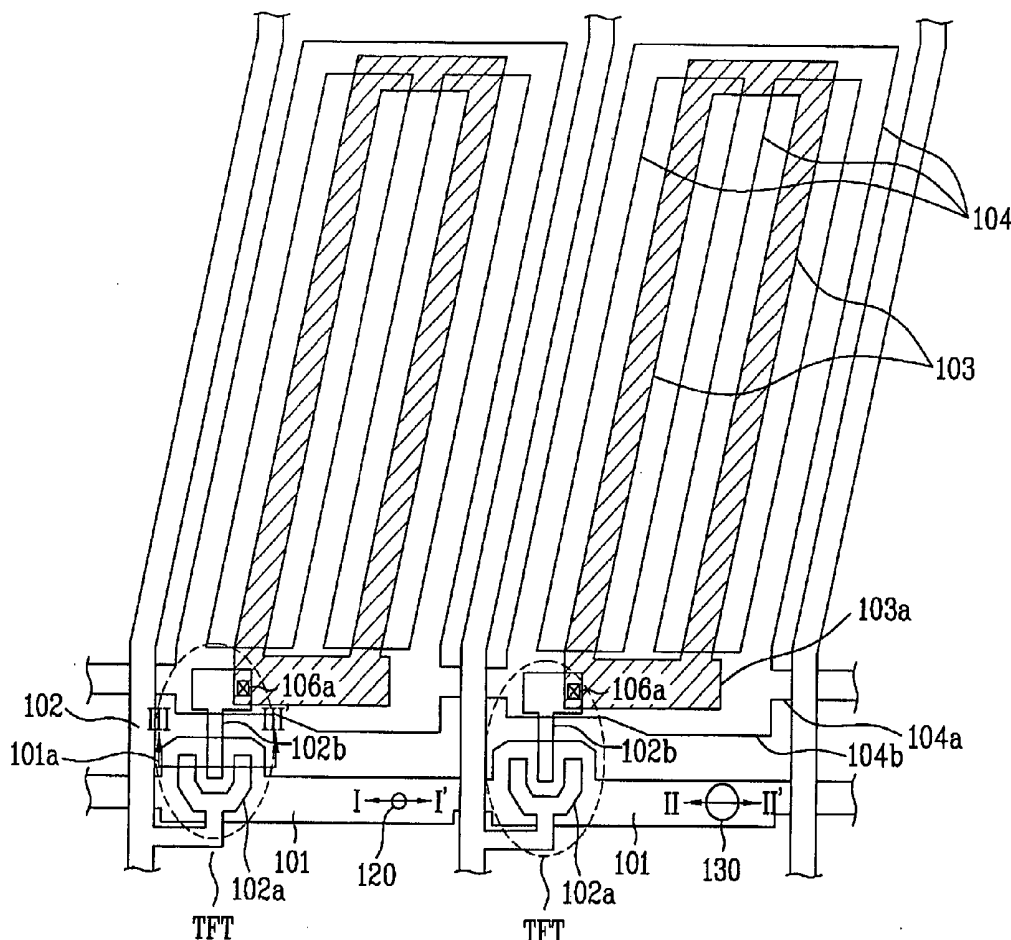

FIG. 1
Related Art

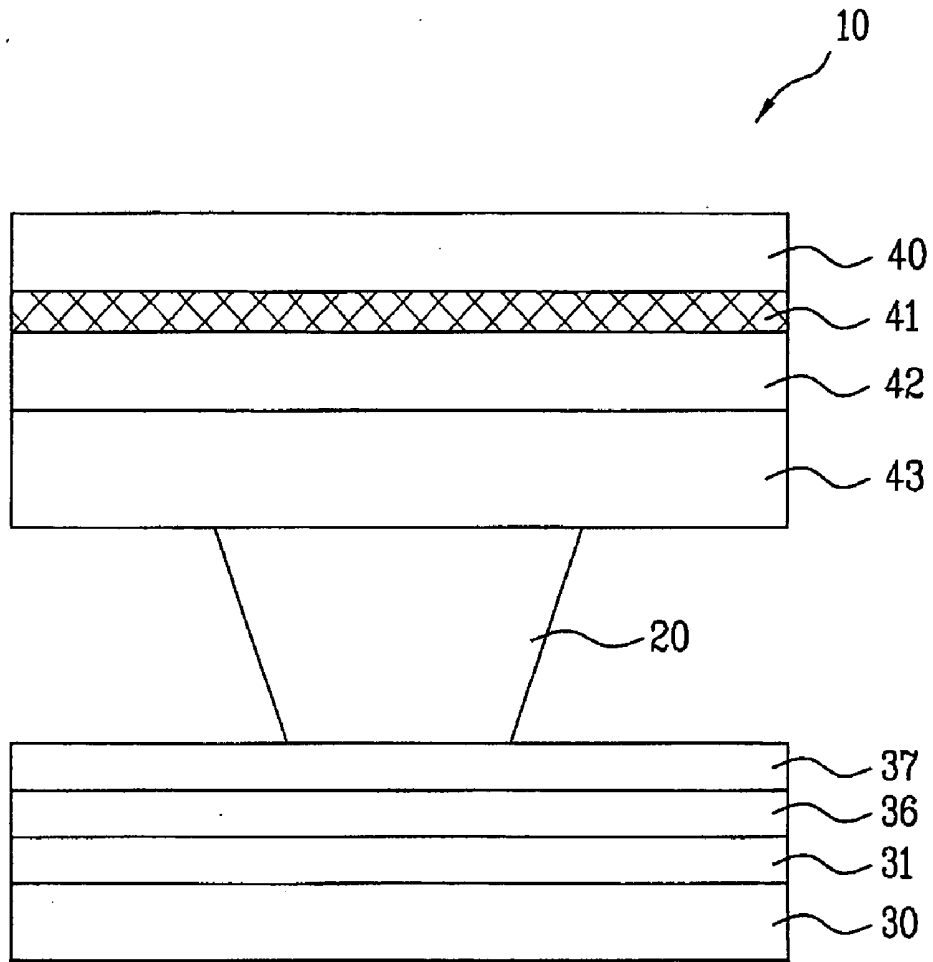

FIG. 2A
Related Art

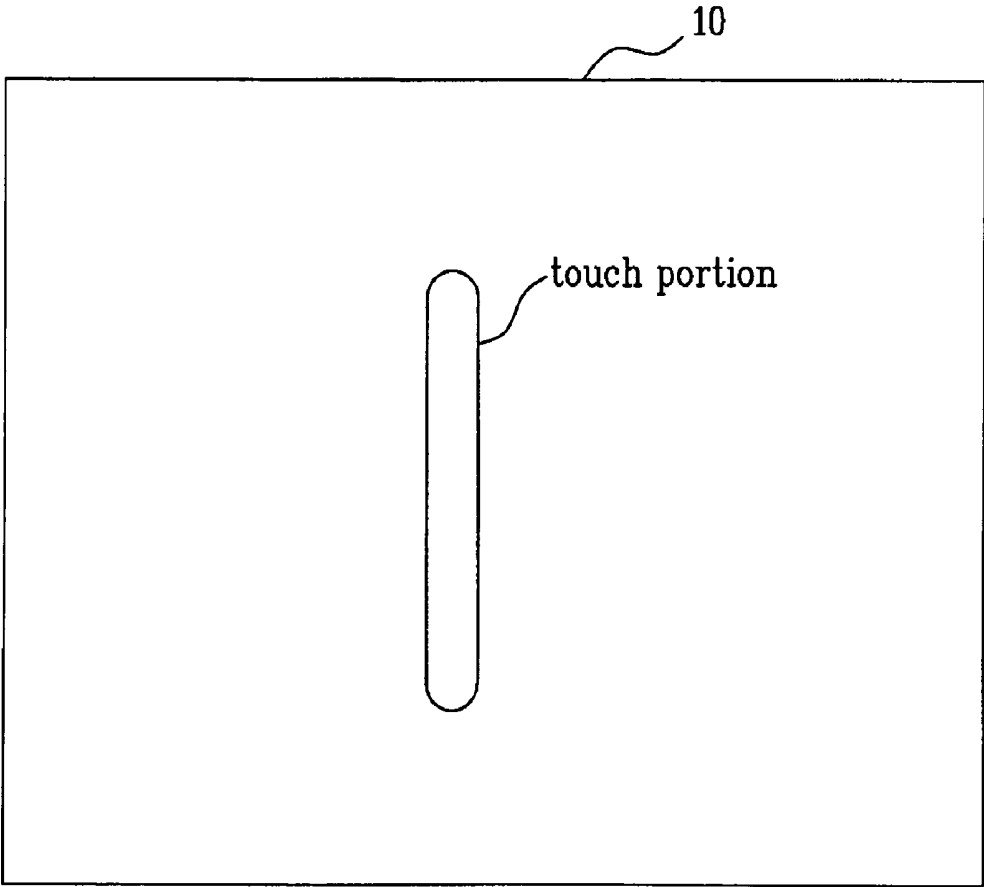
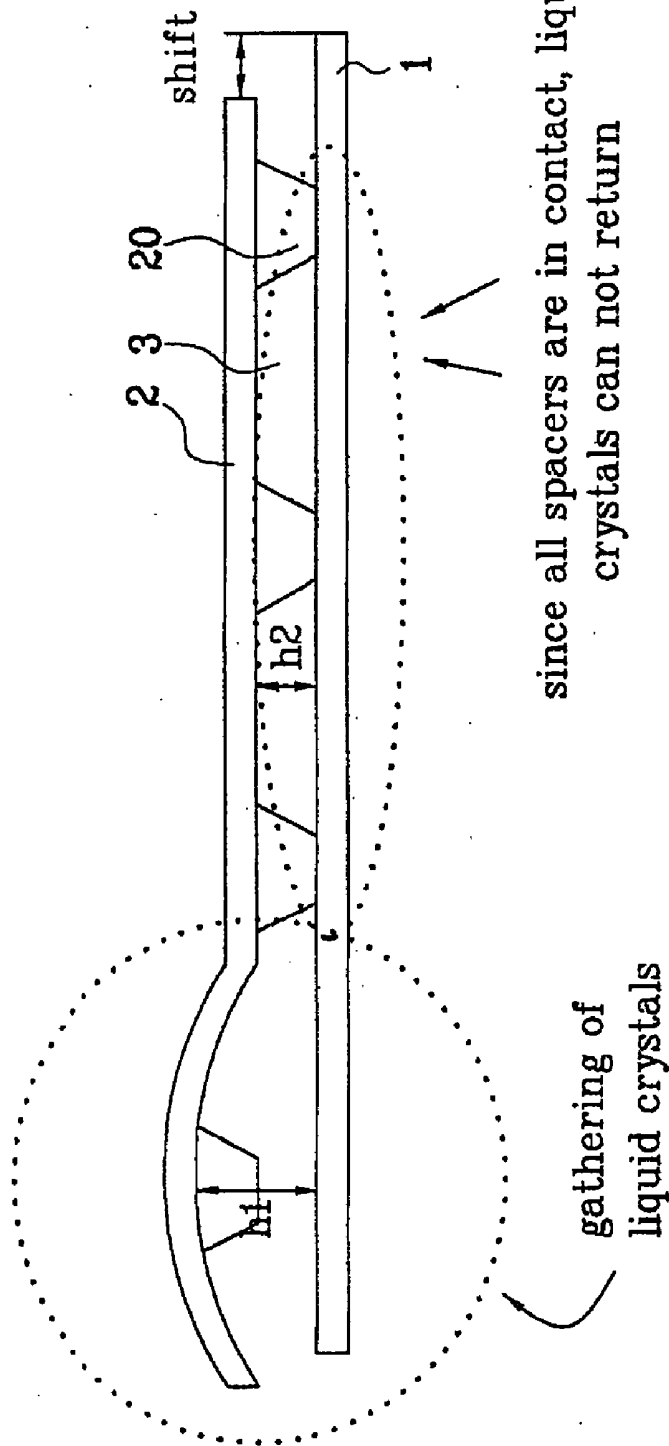

FIG. 2B

Related Art



since all spacers are in contact, liquid crystals can not return

gathering of liquid crystals

FIG. 3

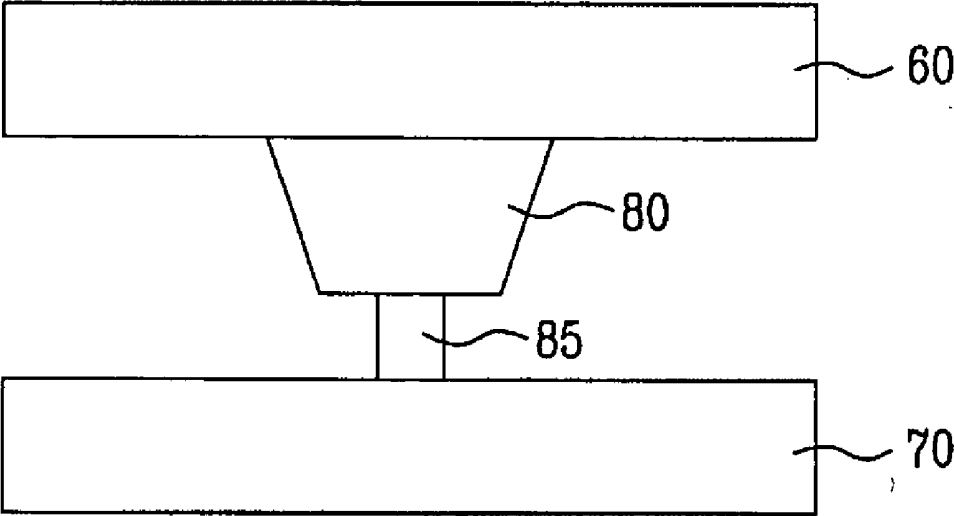

FIG. 4

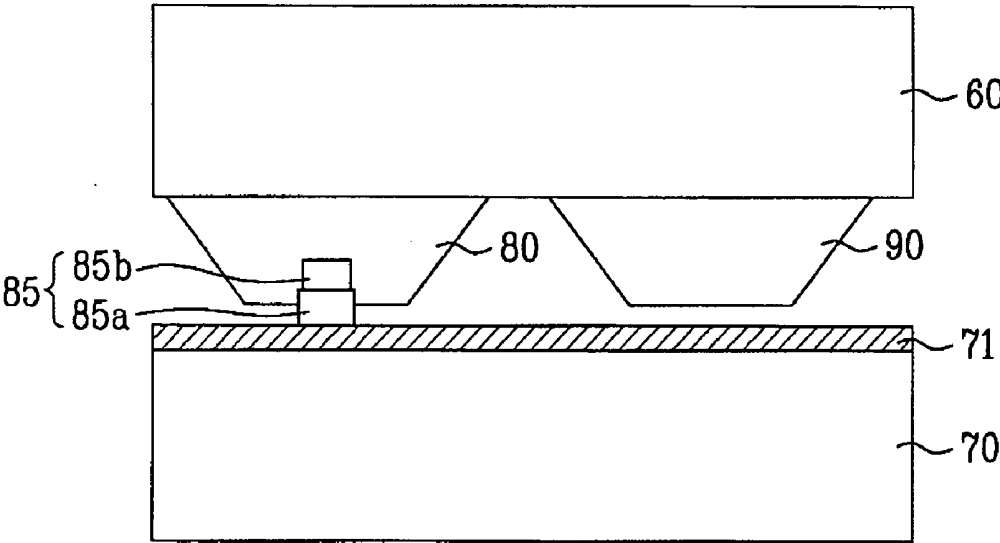

FIG. 5A

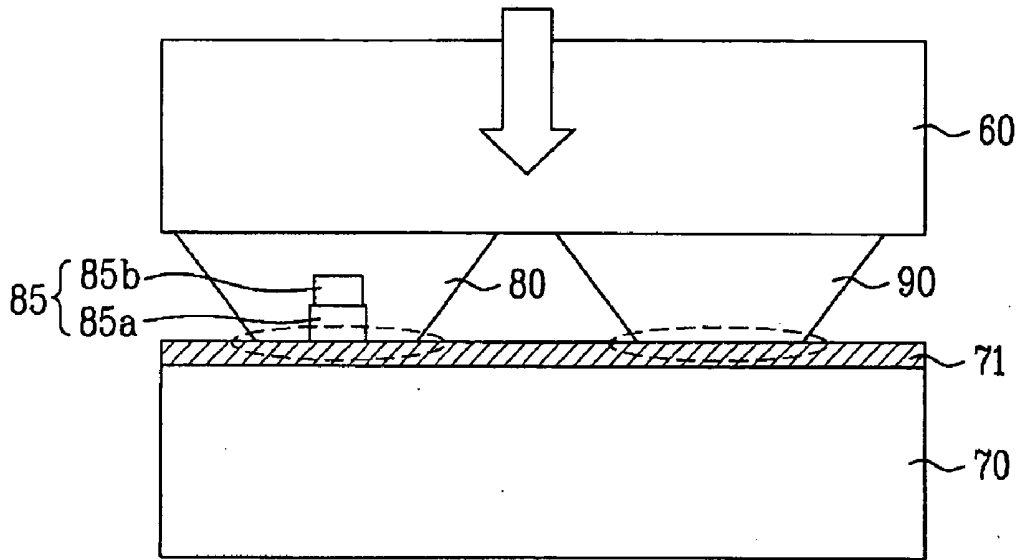

FIG. 5B

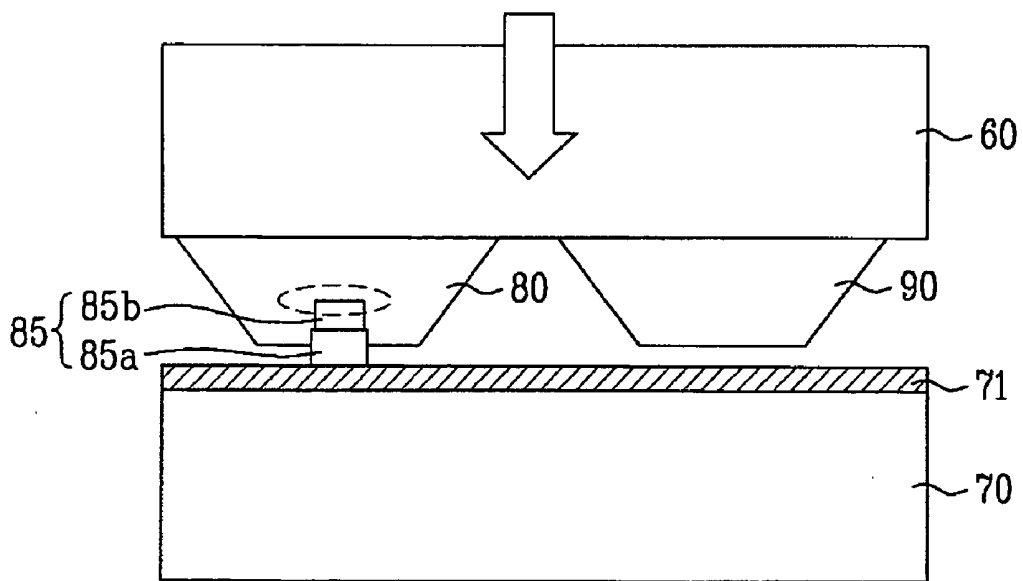

FIG. 6

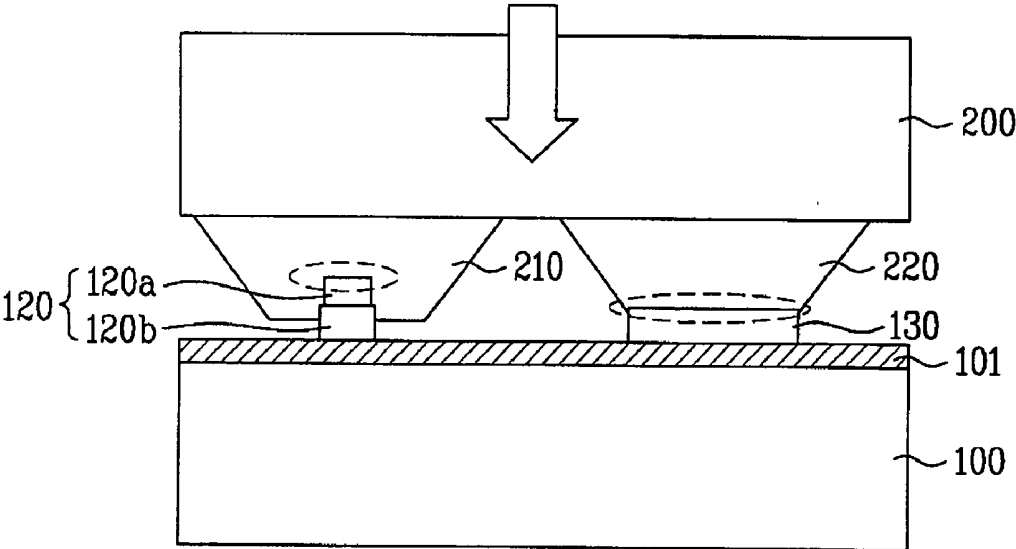
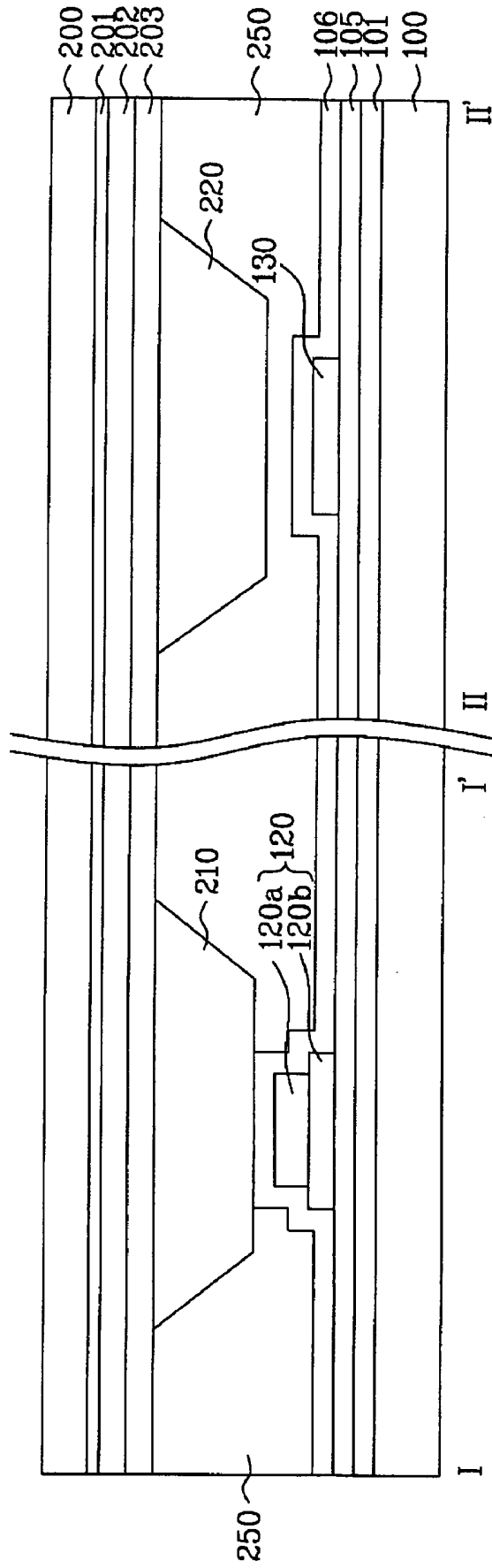

FIG. 8



LIQUID CRYSTAL DISPLAY DEVICE AND METHOD FOR MANUFACTURING THE SAME

[0001] This application claims the benefit of Korean Patent Application 10-2005-088778, filed on Sep. 23, 2005, which is hereby incorporated by reference.

FIELD

[0002] The present invention relates to a liquid crystal display device. More particularly, the present invention relates to a liquid crystal display device, which comprises a protrusion corresponding to a predetermined column spacer to reduce a contact area between the column spacer and an associated substrate facing each other in order to prevent a touch defect, and a compensation pattern corresponding to another column spacer to prevent, so called, a stamp spot (stamp defect) from being created at a specified portion by external force, such as pushing-down and the like, and a method for manufacturing the same.

BACKGROUND

[0003] Advances in information technology result in rapidly increasing demands for display devices having various shapes. Correspondingly, various flat panel display devices, such as liquid crystal display (LCD) devices, plasma display panels (PDPs), electro luminescent display (ELD) devices, vacuum fluorescent display (VFD) devices, and the like, have been continuously investigated, and some of them have been already applied to various apparatuses in practice.

[0004] Among these flat panel display devices, the LCD devices are most widely used for a mobile image display device in place of CRT monitors in view of their merits including excellent image quality, light weight, compactness, and low power consumption. Specifically, the LCD devices are developed for monitors of TV sets which can receive and display broadcasting signals, and monitors of computers in addition to mobile display devices such as notebook computers.

[0005] In order to allow the LCD devices to be applied to various apparatuses as a general screen display device, it is necessary for the LCD devices to realize high quality images such as high definition, high brightness, large size while maintaining merits such as light weight, compactness, and low power consumption.

[0006] Generally, the LCD device comprises a first substrate, a second substrate, a liquid crystal layer interposed between the first and second substrates which are assembled to each other with a predetermined space defined therebetween.

[0007] More specifically, the first substrate is formed with a plurality of gate lines arranged at uniform intervals in one direction, and a plurality of data lines arranged at uniform intervals in another direction perpendicular to the gate lines to define pixel regions. Each of the pixel regions has a pixel electrode formed therein, and a thin film transistor formed at a region where the respective gate lines and the data lines cross each other, and acting to transmit a data signal of the data lines to an associated pixel electrode according to a signal applied to the gate lines.

[0008] In addition, the second substrate is formed with a black matrix layer to shield light from a portion excluding

the pixel regions, a color filter layer of R, G and B to exhibit color images, and a common electrode on the color filter layer to realize the images.

[0009] For such an LCD device, liquid crystals are arranged in the liquid crystal layer interposed between the first and second substrates by electric field generated between the pixel electrode and the common electrode such that an image is exhibited by adjusting an amount of light transmitting through the liquid crystal layer according to an orientation degree of the liquid crystal layer.

[0010] Such an LCD device is referred to as a twisted nematic (TN) mode LCD device. Since the TN mode LCD device has a disadvantage in terms of a narrow view angle, an in-plane switching (IPS) mode LCD device was developed to overcome the disadvantage of the TN mode LCD device.

[0011] For the IPS mode LCD device, the pixel electrode and the common electrode are formed, and parallelly separated a predetermined distance from each other on the pixel region of the first substrate to generate a horizontal electric field between the pixel electrode and the common electrode such that the liquid crystal layer is oriented by the electric field.

[0012] Meanwhile, the LCD device further comprises a spacer formed between the first and second substrate to maintain a constant separation therebetween where the liquid crystal layer is formed.

[0013] The spacer can be, classified into a ball spacer, and a column spacer according to the shapes thereof.

[0014] The ball spacers have a spherical shape, and are scattered on the first and second substrates. The ball spacers move relatively freely even after the first and second substrates are assembled, and have a small contact area with the first and second substrates.

[0015] On the other hand, the column spacer is formed by an array process on the first substrate or the second substrate, and is secured to one of the substrates in a column shape having a predetermined height. Accordingly, the column spacer has a higher contact area than that of the ball spacers.

[0016] A liquid crystal display device having a conventional column spacer will be described with reference to the drawings.

[0017] FIG. 1 is a cross-sectional view illustrating the liquid crystal display device having the column spacer.

[0018] Referring to FIG. 1, the LCD device having the column spacer comprises first and second substrates **30** and **40** facing each other, a column spacer **20** formed between the first and second substrates **30** and **40**, and a liquid crystal layer (not shown) filled between the first and second substrates **30** and **40**.

[0019] The first substrate **30** is formed thereon with gate lines **31** and data lines (not shown) vertically crossing each other to define pixel regions, each of which has a pixel electrode (not shown) formed therein, and thin film transistors (TFT) at respective regions where the gate lines **31** cross the data lines.

[0020] The second substrate **40** is formed thereon with a black matrix layer **41** at a region excluding the pixel regions,

a color filter layer **42** of a stripe shape corresponding to the pixel regions on a longitudinal line horizontal to the data lines, and a common electrode or an overcoat layer **43** on the overall surface.

[0021] Here, the column spacer **20** is formed at a predetermined position above the gate lines **31**.

[0022] In addition, the first substrate **30** is further formed with a gate insulation layer **36** over an entire upper surface including the gate lines **31**, and a passivation layer **37** on the gate insulation layer **36**.

[0023] FIGS. **2A** and **2B** are a plan view, and a cross-sectional view illustrating a touch defect on the liquid crystal display device comprising the column spacer.

[0024] As shown in FIGS. **2A** and **2B**, for the liquid crystal display device comprising the conventional column spacer described above, if an operator touches a surface of a liquid crystal panel **10** in a predetermined direction with a finger or other articles, a spot is formed on a touched portion. Since it is generated by touching the surface of the panel, the spot is called a touch spot, or since the spot is observed on a screen, it is also called a touch defect.

[0025] Such a touch defect is considered to be created due to a large frictional force resulting from a greater contact area between the column spacer **20** and the first substrate **1** facing each other in comparison with the structure employing the ball spacers. That is, since the column spacer **20** has a columnar shape, and has a great contact area with respect to the first substrate **1** compared with the ball spacers, as shown in FIG. **2B**, it takes a longer period of time for the touched portion to recover an original state after shift of the first substrate **1** with respect to the second substrate **2** caused by touch on the surface, thereby allowing the spot to remain on the touched portion until the touched portion recovers the original state.

[0026] However, such a liquid crystal comprising the conventional column spacer has problems as follows.

[0027] First, since the contact area between the column spacer and the substrate facing each other is wide, causing a high frictional force, it takes a long period of time for the touched portion to recover the original state when one of the substrates are shifted with respect to the other due to the touch, thereby causing the spot to be observed while the touched portion is recovered to the original state.

[0028] Second, when the liquid crystal panel comprising the column spacer is brought into a high temperature condition in an upright state, liquid crystals suffer from thermal expansion. In severe cases, the cell gap expands thicker than a height of the column spacer, and causes the liquid crystals to flow down to a lower portion of the liquid crystal panel so that the lower portion of the liquid crystal panel bulges, and looks opaque.

SUMMARY

[0029] A liquid crystal display device comprises first and second substrates that face each other, first and second lines formed on the first substrate in first and second directions that cross each other, respectively. The liquid crystal display device further comprises a protrusion formed at a predetermined portion on the first line, a first column spacer formed on the second substrate so as to correspond to the protrusion

and that has a corresponding surface with respect to the protrusion. The corresponding surface is wider than the protrusion. The liquid crystal display device also comprises a compensation pattern formed at another predetermined portion on the first line where the protrusion is not formed. The compensation pattern has a lower height than the protrusion. The liquid crystal display device then includes a second column spacer corresponding to the compensation pattern, and a liquid crystal layer formed between the first and second substrates.

[0030] In accordance with another aspect of the present invention, a method for manufacturing a liquid crystal display device comprises preparing first and second substrates, forming a first line on the first substrate in a first direction, sequentially depositing an insulation film, a semiconductor material layer, and a source/drain electrode material layer on the first substrate that comprises the first line. The method for manufacturing a liquid crystal display device further comprises applying a photosensitive film that has a first thickness to the source/drain electrode material layer, selectively patterning the photosensitive film to form a first photosensitive film pattern that has the first thickness and a second photosensitive film pattern that has a second thickness lower than the first thickness at predetermined portions on the first line, respectively. The method for manufacturing a liquid crystal display device also includes selectively etching the source/drain electrode material layer and the semiconductor material layer using the first and second photosensitive film patterns as a mask to form a protrusion at a portion corresponding to the first photosensitive film pattern, and a compensation pattern at a portion corresponding to the second photosensitive film pattern, respectively. The method for manufacturing a liquid crystal display device then comprises forming a first column spacer at a portion on the second substrate corresponding to the protrusion, and a second column spacer at a portion on the second substrate corresponding to the compensation pattern. The method for manufacturing a liquid crystal display device further comprises bonding the first and second substrates to each other, and forming a liquid crystal layer between the first and second substrates.

BRIEF DESCRIPTION OF THE DRAWINGS

[0031] The accompanying drawings, which are included to provide a further understanding of the invention and are incorporated in and constitute a part of this application, illustrate embodiment(s) of the invention and together with the description serve to explain the principle of the invention. In the drawings:

[0032] FIG. **1** is a cross-sectional view illustrating a conventional liquid crystal display device comprising a column spacer;

[0033] FIGS. **2A** and **2B** are a plan view, and a cross-sectional view illustrating a touch defect on the liquid crystal display device comprising the column spacer, respectively;

[0034] FIG. **3** is a schematic view illustrating the structure of a protrusion in a liquid crystal display device in accordance with the present invention;

[0035] FIG. **4** is a cross-sectional view illustrating the liquid crystal display device comprising the protrusion shown in FIG. **3** with first and second substrates assembled;

[0036] FIGS. 5A and 5B are cross-sectional views illustrating a contact degree between a column spacer and a substrate facing each other, and deformation of the column spacer according to a degree of external force applied to the liquid crystal display device shown in FIG. 4;

[0037] FIG. 6 is a cross-sectional view illustrating a contact degree between the column spacer and the substrate facing each other, and deformation of the column spacer according to the degree of external force applied to a liquid crystal display device in accordance with the present invention;

[0038] FIG. 7 is a plan view illustrating the liquid crystal display device in accordance with the present invention; and

[0039] FIG. 8 is a cross-sectional view taken along lines I-I' and II-II' of FIG. 7.

DETAILED DESCRIPTION

[0040] Reference will now be made in detail to the preferred embodiments of the present invention, examples of which are illustrated in the accompanying drawings. Wherever possible, the same reference numbers will be used throughout the drawings to refer to the same or like parts.

[0041] FIG. 3 is a schematic view illustrating the structure of a protrusion in a liquid crystal display device in accordance with the present invention.

[0042] Referring to FIG. 3, the liquid crystal display device comprises first and second substrates 70 and 60 facing each other, a column spacer 80 formed at a predetermined portion on the second substrate 60, a protrusion 85 formed on the first substrate 70 to partially contact the column spacer 80 and having a smaller area than an upper surface (namely, an end portion) of the column spacer 80 (that is, a corresponding surface of the column spacer 80 with respect to the protrusion), and a liquid crystal layer (not shown) interposed between the first and second substrates 70 and 60.

[0043] As such, if the liquid crystal display device comprises the protrusion 85, and when an operator touches a surface of the first substrate 70 or the second substrate 60 (with a behavior of rubbing in one direction), causing one of the first and the second substrates 70 and 60 to be shifted with respect to the other, a contact area between the column spacer 80 and the protrusion 85 is defined to an upper surface (namely, an end portion) of the protrusion 85, which is smaller than an upper surface of the column spacer 80 (here, the "upper surface" is referred with reference to the second substrate 60 having the column spacer formed thereon, and thus, the surface of the column spacer 80 contacting the surface of the second substrate 60 is referred to as a "lower surface"), so that a frictional area between the column spacer 80 and the second substrate 60 is reduced in comparison to the conventional liquid crystal display device, thereby reducing frictional force therebetween. Accordingly, when the first substrate 70 or the second substrate 60 is shifted in one direction by touch, the touched substrate can be easily recovered to an original state.

[0044] For the liquid crystal display device comprising such a protrusion, when the first and second substrates 70 and 60 are assembled, the shape of the column spacer 80 corresponding to the protrusion 85 is changed as follows.

First, force is concentrated on a portion of the column spacer 80 corresponding to the protrusion 85, so that a color filter layer (not shown) and a black matrix layer (not shown) under the column spacer 80 are pushed down together.

[0045] As such, if a single layer or a plurality of layers are compressed, when a liquid crystal panel is brought into a high temperature condition, causing a cell gap to be enlarged via thermal expansion of liquid crystals, the column spacer 80 can be recovered to the original state by a compressed degree of the column spacer 80 and the layers under the column spacer 80, and maintain the space between the first and second substrates 70 and 60, thereby preventing gravity defect caused by drooping of the liquid crystals in comparison to the structure not having the protrusion.

[0046] However, in the case where a protrusion having smaller volume and surface area is formed corresponding to the center of the column spacer configured as described above, and when the column spacer and the underlayer thereof are compressed by the protrusion, the force can be concentrated, particularly, on the portion of the column spacer 80 corresponding to the protrusion 85. On this condition, if the first and second substrates 70 and 60 are excessively compressed by external force (that is, possibly causing compression force from a rear side of one of the first and second substrates to become excessive), there occurs a phenomenon wherein the column spacer 80 is compressed by the protrusion 85, and is not recovered to the original state.

[0047] Such a compressing behavior can be conducted by a separate compression test before launching the liquid crystal display device, or during an assembly process for assembling liquid crystal modules.

[0048] FIG. 4 is a cross-sectional view illustrating the liquid crystal display device comprising the protrusion shown in FIG. 3 with first and second substrates assembled. FIGS. 5A and 5B are cross-sectional views illustrating a contact degree between a column spacer and a substrate facing each other, and deformation of the column spacer according to a degree of external force applied to the liquid crystal display device shown in FIG. 4.

[0049] As shown in FIG. 4, for the liquid crystal display device comprising the protrusion between the column spacer and the opposite substrate, at an initial stage of assembling the first and second substrates, a first column spacer 80 is brought into contact with the protrusion 85, and a second column spacer 90 is separated from the first substrate 70. Accordingly, when touch operation is performed in such a way of rubbing a rear side of the first substrate 70 or the second substrate 60 with a slight force, only an upper surface of the protrusion 85 remains in contact with the first column spacer 80. Thus, since recovery of the touched portion to an original state is performed rapidly due to a small contact area after shifting of one of the first and second substrates 70 and 60 with respect to the other, a touch defect is not observed.

[0050] The protrusion 85 is formed by stacking a semiconductor layer pattern 85a at a lower portion of the protrusion, and a metal layer 85b at an upper portion thereof. The protrusion 85 is formed on a gate line 71 or a common line (not shown) on the first substrate 70. Alternatively, the protrusion 85 is formed on a metal component coplanar with the gate line or the common line.

[0051] For the liquid crystal display device comprising the protrusion described above, if the protrusion **85** is excessively compressed by external force as shown in FIG. 5A, the protrusion **85** is crushed by the first column spacer **80**, as shown in FIGS. 5A and 5B. In severe cases, both first and second column spacers **80** and **90** are brought into contact with the first substrate **70**, as shown in FIG. 5A.

[0052] If the compression force is less than the case of FIG. 5A, but greater than the pressure applied between the first and second substrates **70** and **60** when assembling the first and second substrates **70** and **60**, the first column spacer **80** remains in the state of being crushed by the protrusion **85**.

[0053] In this case, if the compression force applied particularly to the first column spacer **80** corresponding to the protrusion **85** is a predetermined pressure or more, the first column spacer **80** is subjected to plastic deformation (crushed by the protrusion), and cannot be recovered to the original state.

[0054] In particular, since the protrusion **85** is formed of a double layer formed by stacking the semiconductor layer pattern **85a** and the source/drain metal layer **85b**, it has a thickness depending on the thickness of the material layers (the semiconductor layer pattern and the source/drain metal layer). In this case, an increase in thickness of the semiconductor layer pattern **85a** and the source/drain metal layer **85b** causes an increase in separation between the first and second column spacers **80** and **90** and the first substrate **70**.

[0055] Accordingly, there is a high possibility of causing the first column spacer **80** to be subjected to the plastic deformation by the protrusion **85** depending on making the protrusion thicker until the second column spacer **90** is brought into contact with the first substrate **70** by continuous external force after the first column spacer **80** is brought into contact with the protrusion **85**. As such, if the first column spacer **80** is subjected to the plastic deformation, a deformed portion of the first column spacer is not recovered to the original state, and remains in the crushed state even after the external force is removed. Thus, this portion is observed as a black spot due to deformation. Such a spot is referred to as a stamp spot, and once the stamp spot is created, it is impossible for the deformed portion to recover the original state.

[0056] According to designs of the liquid crystal display device, the thickness of the semiconductor layer pattern **85a** and the source/drain metal layer **85b** can be changed. Particularly, the stamp spot becomes problematic for the design of the LCD device in which the semiconductor layer pattern **85a** and the source/drain metal layer **85b** are thick.

[0057] Specifically, for such an LCD device, at an initial stage of assembling the first and second substrates, the first column spacer **80** is brought into contact with the protrusion **85**, while the second column spacer **90** is separated from the first substrate **70** by a thickness of the protrusion **85**. Thus, in order to make the second column spacer **90** to contact the first substrate **70**, it is necessary to compress the second column spacer **90** by the thickness of the protrusion **85** with application of external force. At this time, the first and second column spacers **80** and **90** serve to disperse and take their own share of a contact pressure when the second column spacer **90** is brought into contact with the first substrate **70**. However, if the first column spacer **80** is

plastically deformed, it is impossible for the first column spacer **80** to recover the original state.

[0058] A liquid crystal display device having a compensation pattern for preventing compression of the second column spacer on the first substrate corresponding to the second column spacer, and a method for manufacturing the same will be described hereinafter.

[0059] Meanwhile, external force causing deformation of the column spacer is provided in consideration of all cases where the external force can be applied, for example, when determining whether the stamp spot is created on the liquid crystal panel by application of an intended pressure such as a compression test or when the liquid crystal panel is partially compressed during a module process.

[0060] FIG. 6 is a cross-sectional view illustrating a contact degree between a column spacer and a substrate facing each other in the liquid crystal display device according to the present invention, and deformation of the column spacer at that time.

[0061] As shown in FIG. 6, the liquid crystal display device of the present invention comprises a first substrate **100** and a second substrate **200** facing each other, a liquid crystal layer **250** (see FIG. 8) disposed between the first and second substrates **100** and **200**, a gate line **101** formed on the first substrate **100**, a protrusion **120** and a compensation pattern **130** formed at predetermined portions on the gate line **101** of the first substrate **100**, a first column spacer **210** corresponding to the protrusion **120**, and a second column spacer **220** corresponding to the compensation pattern **130**.

[0062] The protrusion **120** is formed by stacking a semiconductor layer pattern **120b** formed at a lower portion of the protrusion, and a metal layer **120a** formed at an upper portion thereof. The compensation pattern **130** is formed of a single semiconductor pattern layer.

[0063] In this structure, with a predetermined pressure due to compression, the second column spacer **220** can be brought into contact with the compensation pattern **130** until the first column spacer **210** is subjected to plastic deformation, by which the first column spacer **210** cannot recover its own original state, after the first column spacer **210** is partially compressed by the protrusion **120**. As such, the first and second column spacers **210** and **220** corresponding to the protrusion **120** and the compensation pattern **130** can share the pressure due to the compression, thereby preventing the first column spacer **210** from being crushed. Accordingly, there is no plastic deformation in the first column spacer so that a stamp spot is prevented from being created.

[0064] FIG. 7 is a plan view illustrating the liquid crystal display device in accordance with the present invention, and FIG. 8 is a cross-sectional view taken along lines I-I' and II-II' of FIG. 7.

[0065] As shown in FIGS. 7 and 8, for the LCD device of the present invention, the first substrate **100** is formed thereon with gate lines **101** and data lines **102** crossing each other to define pixel regions, a thin film transistor (TFT) at each crossing portion of the gate lines **101** and the data lines **102**, a first storage electrode **103a** electrically connected with a drain electrode **102b** of each thin film transistor, a pixel electrode **103** branched from the first storage electrode **103a**, a common line **104a** parallelly adjacent to both

consecutive gate lines in each pixel region, a common electrode **104** branched from the common line **104a** to alternate with the pixel electrode **103**, and a second storage electrode **104b** connected with the common electrode **104** while overlapping with the first storage electrode **103a**.

[0066] Here, the thin film transistor has a channel region defined between a U-shaped source electrode **102a** and the drain electrode **102b**. Thus, the channel region is also defined in a U shape corresponding to an inner shape of the source electrode **102a**. The thin film transistor comprises a gate electrode **101a** protruding from the gate line **101**, the U-shaped source electrode **102a** protruding from the data line **102**, and the drain electrode **102b** separated a predetermined distance from the source electrode **102b** while inserting inside the U shape of the source electrode **102a**. In addition, the thin film transistor further comprises a semiconductor layer (not shown) under the data line **102**, source electrode **102a**, drain electrode **102b**, and the channel region between the source electrode **102a** and the drain electrode **102b**.

[0067] Here, the semiconductor layer is formed by stacking a non-crystalline silicon layer (not shown) and then an n+ layer (impurity layer) (not shown) on the silicon layer, and removing a portion of the n+ layer (impurity layer) in the channel region between the source electrode **102a** and the drain electrode **102b**. The semiconductor layer may be selectively formed only under the source/drain electrodes **102a** and **102b**, and the channel region therebetween. Alternatively, the semiconductor layer may be formed under the data line **102**, the source electrode **102a**, and the drain electrode **102b** as well as channel region. Meanwhile, although the liquid crystal display device is illustrated as comprising the U-shaped source electrode **102a** and the U-shaped channel in the drawings, the liquid crystal display device may have the source electrode **102a** having a “-” shape protruding from the data line **102** or in other shapes.

[0068] Here, the gate line **101**, the common line **104a** and the common electrode **104** are formed of the same material on the same layer.

[0069] In addition, a gate insulation layer **105** is interposed between the gate line **101** and the semiconductor layer, and a passivation layer **106** is interposed between the data line **102** and the pixel electrode **103**.

[0070] Meanwhile, the second storage electrode **104b** is connected with the common line **104a** passing through the pixel region, the first storage electrode **103a** overlapped on the second storage electrode **104b**, and the gate insulation layer **105** and the passivation layer **106** interposed between these two electrodes constitute a storage capacitor.

[0071] Here, the drain electrode **102b** and the first storage electrode **103a** formed on different layers are brought into contact with each other via a contact hole **106a** which is formed by removing the passivation layer **106** at a predetermined portion on the drain electrode **102b**.

[0072] In addition, a protrusion **120** is formed at a predetermined portion on the gate line **101** or the common line **104a**, and comprises a semiconductor layer pattern **120b** on the same layer as that of the semiconductor layer **107a**, and a source/drain metal layer **120a** on the same layer as that of the source/drain electrodes **102a/102b**, which are stacked in this order.

[0073] The semiconductor pattern **120b** has a thickness of about 0.2-0.3 μm , and the source/drain metal layer **120a** has a thickness of about 0.2-0.4 μm . Unlike a remaining portion where the protrusion **120** is not formed, the portion having the protrusion **120** formed thereon is formed as a step of about 0.4-0.7 μm . In the liquid crystal display device comprising the protrusion **120**, the protrusion **120** becomes to face the first column spacer **210** formed on the second substrate **200** when the first and second substrates **100** and **200** are assembled to form a cell gap therebetween. At this time, an upper surface (namely, an end portion) of the protrusion **120** is smaller than an upper surface of the first column spacer **210** (in this case, it is assumed that a surface of the first column spacer **210** brought into contact with the second substrate **200** is a lower surface), so that the first column spacer **210** is brought into contact with the protrusion **120** across the upper surface of the protrusion **120** when the first column spacer **210** is brought into contact with the protrusion **120**.

[0074] Here, since the protrusion **120** is formed with the passivation layer **106** on a remaining region of the protrusion excluding the contact hole **106a**, a contact portion with the column spacer **210** formed on the second substrate **200** is defined in the passivation layer **106** on the protrusion **120**.

[0075] In addition, a compensation pattern **130** is formed at a predetermined portion on the gate line **101** where the protrusion **120** is not formed. The compensation pattern **130** is formed on the same layer as that of the semiconductor pattern **120b**, and has a lower height than that of the protrusion **120**.

[0076] Although the protrusion **120** and the compensation pattern **130** are illustrated as being formed on the gate line **101** in the drawings, the protrusion **120** and the compensation pattern **130** may be formed on the common line **104a**. Alternatively, the protrusion **120** and the compensation pattern **130** may be formed on the second storage electrode **104b** which is formed of the same metal as that of the gate line **101** and the common line **104a**.

[0077] The second substrate **200** faces the first substrate **100**, and is formed thereon with a black matrix layer **201** corresponding to the region (region of the gate line and the data line) excluding the pixel region, a color filter layer **202**, and an overcoat layer **203** for flatness of the second substrate **200** comprising the black matrix layer **201** and the color filter layer **202**.

[0078] In addition, the first column spacer **210** is formed on a portion of the overcoat layer **203** corresponding to the protrusion **120**, and the second column spacer **220** is formed on a portion of the overcoat layer **203** corresponding to the compensation pattern **130**.

[0079] Here, the first column spacer **210** and the second column spacer **220** have the same height on the overcoat layer **203**. When the first column spacer **210** is brought into contact with the protrusion **120** upon assembly of the first and second substrate to form the cell gap, the second column spacer **220** remains in a state of being separated a predetermined distance from the first substrate **100**, thereby reducing a ratio of contact area between the overall column spacers and the first substrate **100**. Accordingly, touch is conducted in a state wherein the protrusion **120** is brought into contact with the first column spacer **210**, and even when the first

substrate **100** or the second substrate **200** is shifted in one direction by the touch, the touched substrate can be easily recovered to an original state due to a smaller contact area, thereby preventing non-uniform brightness due to the touch.

[0080] Upon a compression test with application of a predetermined pressure or more, initially, the first column spacer **210** is brought into contact with the protrusion **120**, and as the pressure increases, the second column spacer **220** is then brought into contact with an upper surface (namely, an end portion) of the compensation pattern **130** of the first substrate **100**, which corresponds to the second column spacer **220**, so that a contact area therebetween increases, thereby dispersing the pressure upon the compression test. At this time, the compensation pattern **130** can slightly relieve the step difference with the protrusion **120**, so that the second column spacer **220** is brought into contact with the upper surface of the first substrate **100** while the first column spacer **210** is deformed by the compression test. Then, the column spacers are brought into contact with the first substrate across a wider contact area from when the second column spacer **220** contacts the upper surface of the first substrate **100**.

[0081] Accordingly, while the first column spacer **210** contacts the protrusion **120**, the pressure is concentrated on the first column spacer **210** via the protrusion **120** so that, even when the first column spacer **210** deforms, the second column spacer **220** is brought into contact with the first substrate **100** before severe deformation of the second column spacer **220** occurs (that is, before recovery of the second column spacer **220** into the original state becomes impossible), thereby enabling the column spacers **210** and **220** to recover the original state after the compression test.

[0082] Meanwhile, the first and second column spacers **210** and **220** may have various shapes, including a circular shape, a rectangular shape, and other polygonal shapes in a transverse cross-section. Advantageously, the first and second column spacers **210** and **220** may have the circular shape or a regular polygonal shape in view of an alignment margin upon a process.

[0083] The protrusion **120** and the compensation pattern **130** may also have various shapes, including a circular shape, a rectangular shape, and other polygonal shapes in a transverse cross-section. In this case, the transverse cross-section of the protrusion **120** is formed as small as possible in a pattern which can minimize a contact area upon touch. The compensation pattern **130** serves to disperse contact pressure by increasing the contact area at a predetermined pressure or more, and has at least an area greater than or equal to the area of the protrusion **120**. Advantageously, the compensation pattern **130** has an area greater than or equal to the upper surface of the second column spacer **220** in view of dispersion of the pressure upon compression.

[0084] Meanwhile, the compensation pattern **130** is formed on the same layer as that of the semiconductor layer (not shown) formed under the source/drain electrodes **102a/102b** of the thin film transistor. In a 5 mask process, the compensation pattern **130** is formed at the same time with a process of patterning the semiconductor layer, and in a 4 mask process, the compensation pattern **130** is formed at the same time with a process of patterning the source/drain electrode material layer and the semiconductor material layer.

[0085] More specifically, in the 5 mask process, the semiconductor layer is formed of the semiconductor material layer along with the compensation pattern **130** by patterning while the semiconductor pattern is formed as the lower layer of the protrusion **120**. In this case, the semiconductor layer of the thin film transistor, the semiconductor layer pattern **120a** as the lower layer of the protrusion, and the corresponding portion of the compensation pattern **130** are defined as a light shielding part or a transmission part of the mask for patterning (if a photosensitive film formed on the semiconductor material layer for patterning is a positive photosensitive material, it is defined as the light shielding part, and if the photosensitive film is a negative photosensitive material, it is defined as the transmission part).

[0086] In the 4 mask process, the semiconductor material layer, and the source/drain electrode material layer are formed in a predetermined pattern via a single diffraction exposure mask. In this case, a portion for the channel region of the thin film transistor, and a portion for the compensation pattern **130** are defined as a translucent part. A portion for the data line **102**, a portion for the source/drain electrodes **102a/102b**, and a portion for the protrusion **120** are defined as the light shielding part or the transmission part (if a photosensitive film formed on the source/drain electrode material layer for patterning is the positive photosensitive material, it is defined as the light shielding part, and if the photosensitive film is the negative photosensitive material, it is defined as the transmission part).

[0087] Meanwhile, in the 4 mask process, a diffraction exposure mask for patterning the semiconductor material layer and the source/drain electrode material layer is formed with a plurality of linear slits at a portion of the translucent part corresponding to the channel region, and a plurality of concentric circular slits having different sizes at a portion of the translucent part corresponding to the compensation pattern **130**. It is to use a diffraction exposure mask having the linear slits at a portion of the translucent part corresponding to the compensation pattern **130**.

[0088] The diffraction exposure mask have a plurality of slits on the translucent part corresponding to the portion for the compensation pattern and the portion for the channel region. A width of each slit and a distance between the slits can be adjusted to obtain a resolution degree greater than which can be realized by a combination of an exposure device and the photosensitive film and to perform exposure uniformly.

[0089] Although the above embodiments have been described in view of the IPS mode liquid crystal display device, the present invention is applicable to the TN mode liquid crystal display device. The TN mode liquid crystal display device of the present invention is similar to the IPS mode liquid crystal display device described above, except that the pixel electrode is formed in a single pattern on the pixel region of the first substrate, and the common electrode is formed on the entire surface of the second substrate. For the TN mode liquid crystal display device, since the common line is not formed in the pixel region, the first and second column spacers, and the protrusion are formed on the gate line.

[0090] As apparent from the above description, the liquid crystal display device and the method for manufacturing the same according to the invention have advantageous effects as follows.

[0091] First, the protrusion is brought into contact with the first column spacer having a wider corresponding area than an upper surface of the protrusion when assembling the first and second substrates to form the cell gap, so that a significantly small contact area is created between all column spacers and the corresponding substrate (first substrate) by touch, thereby enabling easy recovery of the touched substrate into an original state after being shifted by the touch.

[0092] Second, when forming the data line, the protrusion, and the like, the compensation pattern is formed lower than the protrusion so that, when assembling the first and second substrate to form the cell gap therebetween, the first column spacer is brought into contact with the protrusion, and then, as the pressure increases upon the compression test, the second column spacer is brought into contact with the compensation pattern, thereby gradually increasing a contact area with the compensation pattern from an upper surface thereof. With this structure, the LCD device of the present invention has an advantageous effect in that the pressure is not concentrated on a specific portion, but dispersed upon the compression test. Accordingly, the pattern including the column spacers are not crushed by compression, thereby preventing the stamp spot (compression spot) and the like from being created.

[0093] Third, the first column spacer is compressed to a predetermined depth by the protrusion after the first column spacer contacts with the protrusion. In this case, when liquid crystal is expanded under a high temperature condition, the protrusion is recovered into an original state by the elasticity of the first column spacer. At this time, the first column spacer remains in contact with the protrusion continuously, thereby preventing liquid crystals from flowing down to a lower end of a liquid crystal panel near the ground. Accordingly, it is possible to relieve gravity defect.

[0094] It will be apparent to those skilled in the art that various modifications and variations can be made in the present invention without departing from the spirit or scope of the inventions. Thus, it is intended that the present invention covers the modifications and variations of this invention provided they come within the scope of the appended claims and their equivalents.

What is claimed is:

1. A liquid crystal display device, comprising:
 - first and second substrates that face each other;
 - a plurality of column spacers formed on the second substrate;
 - a plurality of protrusions formed at a predetermined portion on the first substrate; and
 - a plurality of compensation patterns formed at another predetermined portion on the first substrate.
2. The liquid crystal display device according to claim 1, wherein the compensation patterns are formed at a portion where the protrusions are not formed.
3. The liquid crystal display device according to claim 1, wherein the column spacers comprise a plurality of first column spacers and a plurality of second column spacers.
4. The liquid crystal display device according to claim 3, wherein end portions of the first column spacers face end portions of the protrusions with each other.

5. The liquid crystal display device according to claim 4, wherein the end portion of the first column spacer has a wider area than the end portion of the protrusion.

6. The liquid crystal display device according to claim 3, wherein end portions of the second column spacers face end portions of the compensation pattern with each other.

7. The liquid crystal display device according to claim 6, wherein the end portion of the second column spacer has a smaller area than and an equal area to the end portion of the compensation pattern.

8. The liquid crystal display device according to claim 1, wherein the compensation pattern has a lower height than the protrusions.

9. The liquid crystal display device according to claim 1, further comprising:

- a plurality of gate lines on the first substrate;
 - a plurality of data lines formed vertically with respect to the gate lines; and
 - a plurality of thin film transistors formed adjacent to each crossing portion of the gate lines and the data lines.
10. The liquid crystal display device according to claim 9, wherein the thin film transistor comprises:

- a gate electrode that protrudes from the gate line;
- a source electrode that protrudes from the data line;
- a drain electrode separated from the source electrode; and
- a semiconductor layer that partially overlaps with the source/drain electrodes between the gate electrode and source/drain electrodes.

11. The liquid crystal display device according to claim 10, wherein the protrusion comprises an upper layer and a lower layer, the upper layer being on the same layer with the source/drain electrodes and the lower layer being on the same layer with the semiconductor layer.

12. The liquid crystal display device according to claim 11, wherein the lower layer has a thickness of about 0.2-0.3 μm , and the upper layer has a thickness of about 0.2-0.4 μm .

13. The liquid crystal display device according to claim 10, wherein the compensation pattern is on the same layer with the semiconductor layer.

14. The liquid crystal display device according to claim 1, wherein an end portion of the compensation pattern has a wider area than an end portion of the protrusion.

15. The liquid crystal display device according to claim 3, wherein the first column spacer and the second column spacer have various shapes, including a circular shape, a rectangular shape, or other polygonal shapes in a transverse cross-section.

16. The liquid crystal display device according to claim 1, wherein the protrusion and the compensation pattern have various shapes, including a circular shape, a rectangular shape, or other polygonal shapes in a transverse cross-section.

17. The liquid crystal display device according to claim 1, further comprising a passivation layer interposed between the column spacers and the protrusions or compensation patterns.

18. A method for manufacturing a liquid crystal display device, comprising:

preparing first and second substrates;
forming a plurality of column spacers on the second substrate;
forming a plurality of protrusions at a predetermined portion on the first substrate; and
forming a plurality of compensation patterns at another predetermined portion on the first substrate.

19. The method according to claim 18, the column spacers comprise a plurality of first column spacers and second column spacers.

20. The method according to claim 19, wherein the step of preparing the first substrate comprises the steps of:

forming a first line on the first substrate;

sequentially forming an insulation film, a semiconductor material layer, and a source/drain electrode material layer over the first substrate;

forming a photosensitive pattern that has a first thickness in corresponding to the first column spacers and a second thickness in corresponding to the second column spacers;

selectively etching the source/drain electrode material layer and the semiconductor material layer using the photosensitive patterns to form a protrusion and a compensation pattern.

21. The method according to claim 20, wherein the second thickness of the photosensitive pattern is lower than the first thickness of the photosensitive pattern.

22. The method according to claim 21, wherein the protrusion is formed in the region where the photosensitive pattern with the first thickness is located, and the compensation pattern is formed in the region where the photosensitive pattern with the second thickness is located.

23. The method according to claim 20, wherein the compensation pattern has a lower height than the protrusion.

24. The method according to claim 20, wherein the photosensitive pattern is formed using a diffraction exposure mask.

25. The method according to claim 24, wherein a portion of the diffraction exposure mask corresponding to the first thickness of the photosensitive pattern is a light shield portion, and a portion of the diffraction exposure mask corresponding to the second thickness of the photosensitive pattern is a translucent portion that comprises a plurality of slits.

26. The method according to claim 25, wherein the photosensitive pattern is formed of a positive photosensitive material.

27. The method according to claim 24, wherein a portion of the diffraction exposure mask corresponding to the first thickness of the photosensitive pattern is a transmission portion, and a portion of the diffraction exposure mask corresponding to the second thickness of the photosensitive pattern is a translucent portion that comprises a plurality of slits.

28. The method according to claim 27, wherein the photosensitive pattern is formed of a negative photosensitive material.

29. The method according to claim 25 or 27, wherein the slits comprise concentrically circular slits.

30. The method according to claim 20, further comprising forming a second line vertically with the first line, source/

drain electrodes in the same layer as the second line, and a semiconductor layer comprising a channel region positioned between the source electrode and drain electrode.

31. The method according to claim 30, wherein the photosensitive pattern has the first thickness in corresponding to the source and drain electrodes and the second thickness in corresponding to the channel region.

32. The method according to claim 18, wherein the protrusion comprises an upper layer and a lower layer, the upper layer being on the same layer with the source/drain electrodes and the lower layer being on the same layer with the semiconductor layer.

33. The method according to claim 32, wherein the lower layer has a thickness of about 0.2-0.3 μm , and the upper layer has a thickness of about 0.2-0.4 μm .

34. The method according to claim 18, wherein the compensation pattern is on the same with the semiconductor layer.

35. The method according to claim 20, wherein an end portion of the first column spacer has a greater area than an end portion of the protrusion.

36. The method according to claim 20, wherein an end portion of the second column spacer has a smaller area than or an equal to an end portion of the compensation pattern.

37. The method according to claim 19, wherein the first column spacer and the second column spacer have various shapes, including a circular shape, a rectangular shape, or other polygonal shapes in a transverse cross-section.

38. The method according to claim 18, wherein the protrusion and the compensation pattern have various shapes, including a circular shape, a rectangular shape, or other polygonal shapes in a transverse cross-section.

39. The liquid crystal display device according to claim 18, further comprising forming a passivation layer over the entire surface of the first substrate after forming the protrusions and the compensation patterns.

40. A method for manufacturing a liquid crystal display device, comprising:

arranging a first substrate and a second substrate to face each other;

forming first and second lines on the first substrate such that the first and second lines cross each other;

forming a protrusion at a predetermined portion on the first line;

forming a first column spacer on the second substrate so as to correspond to the protrusion and having a corresponding surface with respect to the protrusion, the corresponding surface being wider than the protrusion;

forming a compensation pattern at another predetermined portion on the first line where the protrusion is not formed, and having a lower height than the protrusion;

forming a second column spacer corresponding to the compensation pattern; and

forming a liquid crystal layer between the first and second substrates.

41. The method for manufacturing a liquid crystal display device according to claim 40, wherein the first line is a gate line or a common line, and the second line is a data line.

42. The method for manufacturing a liquid crystal display device according to claim 41, further comprising:

forming a thin film transistor at each crossing portion of the gate line and the data line.

43. The method for manufacturing a liquid crystal display device according to claim 42, wherein the thin film transistor comprises:

a gate electrode that protrudes from the gate line;

a source electrode that protrudes from the data line;

a drain electrode separated from the source electrode while being formed on the same layer as that of the source electrode; and

a semiconductor layer that partially overlaps with the source/drain electrodes above the gate electrode.

44. The method for manufacturing a liquid crystal display device according to claim 43, wherein the protrusion comprises an upper layer and a lower layer, the upper layer being on the same layer with the source/drain electrodes and the lower layer being on the same layer with the semiconductor layer.

45. The method for manufacturing a liquid crystal display device according to claim 44, wherein the lower layer has a thickness of about 0.2-0.3 μm , and the upper layer has a thickness of about 0.2-0.4 μm .

46. The method for manufacturing a liquid crystal display device according to claim 43, wherein the compensation pattern is on the same layer with the semiconductor layer.

47. The method for manufacturing a liquid crystal display device according to claim 40, wherein the compensation pattern has an upper surface wider than an upper surface of the protrusion.

48. The method for manufacturing a liquid crystal display device according to claim 40, wherein the first column spacer and the second column spacer have the same height.

49. The method for manufacturing a liquid crystal display device according to claim 40, wherein the first column spacer and the second column spacer have various shapes, including a circular shape, a rectangular shape, or other polygonal shapes in a transverse cross-section.

50. The method for manufacturing a liquid crystal display device according to claim 40, wherein the protrusion and the compensation pattern have various shapes, including a circular shape, a rectangular shape, or other polygonal shapes in a transverse cross-section.

* * * * *

专利名称(译)	液晶显示装置及其制造方法		
公开(公告)号	US20070070281A1	公开(公告)日	2007-03-29
申请号	US11/479428	申请日	2006-06-29
[标]申请(专利权)人(译)	乐金显示有限公司		
申请(专利权)人(译)	LG 飞利浦LCD CO., LTD.		
当前申请(专利权)人(译)	LG DISPLAY CO., LTD.		
[标]发明人	CHOI KEE SEOK		
发明人	CHOI, KEE SEOK		
IPC分类号	G02F1/1343 G02F1/1339		
CPC分类号	G02F1/13394 G02F2001/13396 G02F1/1362		
优先权	1020050088778 2005-09-23 KR		
其他公开文献	US7701540		
外部链接	Espacenet USPTO		

摘要(译)

一种液晶显示装置，包括彼此面对的第一和第二基板，分别在彼此交叉的第一和第二方向上形成在第一基板上的第一和第二线。液晶显示装置还包括形成在第一线上的预定部分处的突起，形成在第二基板上的第一柱状间隔物，以对应于突起并且具有相对于突起的相应表面。相应的表面比突起宽。液晶显示装置还包括补偿图案，该补偿图案形成在第一线上的另一预定部分处，其中未形成突起，并且具有比突起低的高度，第二柱状衬垫对应于补偿图案。然后，液晶显示装置包括在第一和第二基板之间的液晶层。还公开了一种制造LCD器件的方法。

