



US007580108B2

(12) **United States Patent**  
**Chang et al.**

(10) **Patent No.:** **US 7,580,108 B2**  
(45) **Date of Patent:** **Aug. 25, 2009**

(54) **LIQUID CRYSTAL DISPLAY DEVICE AND METHOD OF REPAIRING BAD PIXELS THEREIN**

FOREIGN PATENT DOCUMENTS

(75) Inventors: **Jong-woong Chang**, Cheonan-si (KR);  
**Shin-tack Kang**, Seongnam-si (KR)

KR	100149300	6/1998
KR	1020040018883	3/2004
KR	1020050105591	11/2005

(73) Assignee: **Samsung Electronics Co., Ltd.**,  
Gyeonggi-do (KR)

\* cited by examiner

(\*) Notice: Subject to any disclaimer, the term of this patent is extended or adjusted under 35 U.S.C. 154(b) by 108 days.

*Primary Examiner*—David Nelms  
*Assistant Examiner*—Phu Vu  
(74) *Attorney, Agent, or Firm*—Haynes and Boone, LLP

(21) Appl. No.: **11/934,656**

(57) **ABSTRACT**

(22) Filed: **Nov. 2, 2007**

(65) **Prior Publication Data**  
US 2008/0117349 A1 May 22, 2008

(30) **Foreign Application Priority Data**  
Nov. 3, 2006 (KR) ..... 10-2006-0108410

(51) **Int. Cl.**  
*G02F 1/13* (2006.01)  
(52) **U.S. Cl.** ..... 349/192; 349/54; 349/55  
(58) **Field of Classification Search** ..... 349/54-55,  
349/192  
See application file for complete search history.

A liquid crystal display device and a method of repairing bad pixels thereof, in which the bad pixels can be efficiently and easily repaired, includes a first insulating substrate, a gate wiring and a storage wiring arranged substantially parallel to each other in a first direction on the first insulating substrate, a data wiring intersecting the gate and storage wirings in an insulated manner and arranged substantially in a second direction, and a pixel electrode formed on a pixel area defined by the gate and data wirings. The storage wiring includes a horizontal portion arranged substantially in the first direction and at least a part of which does not overlap the pixel electrode, and a vertical portion branching off substantially in the second direction from the horizontal portion and overlapping the data wiring.

(56) **References Cited**  
U.S. PATENT DOCUMENTS  
7,339,633 B2\* 3/2008 Jeoung et al. .... 349/38

**21 Claims, 14 Drawing Sheets**

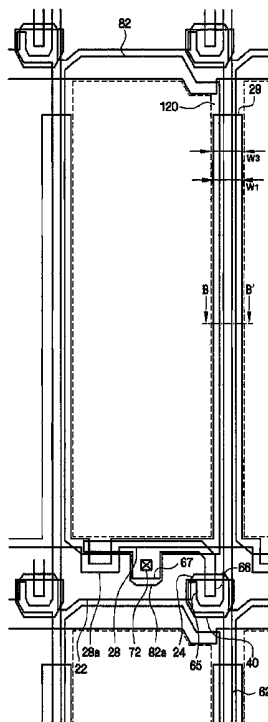

FIG. 1

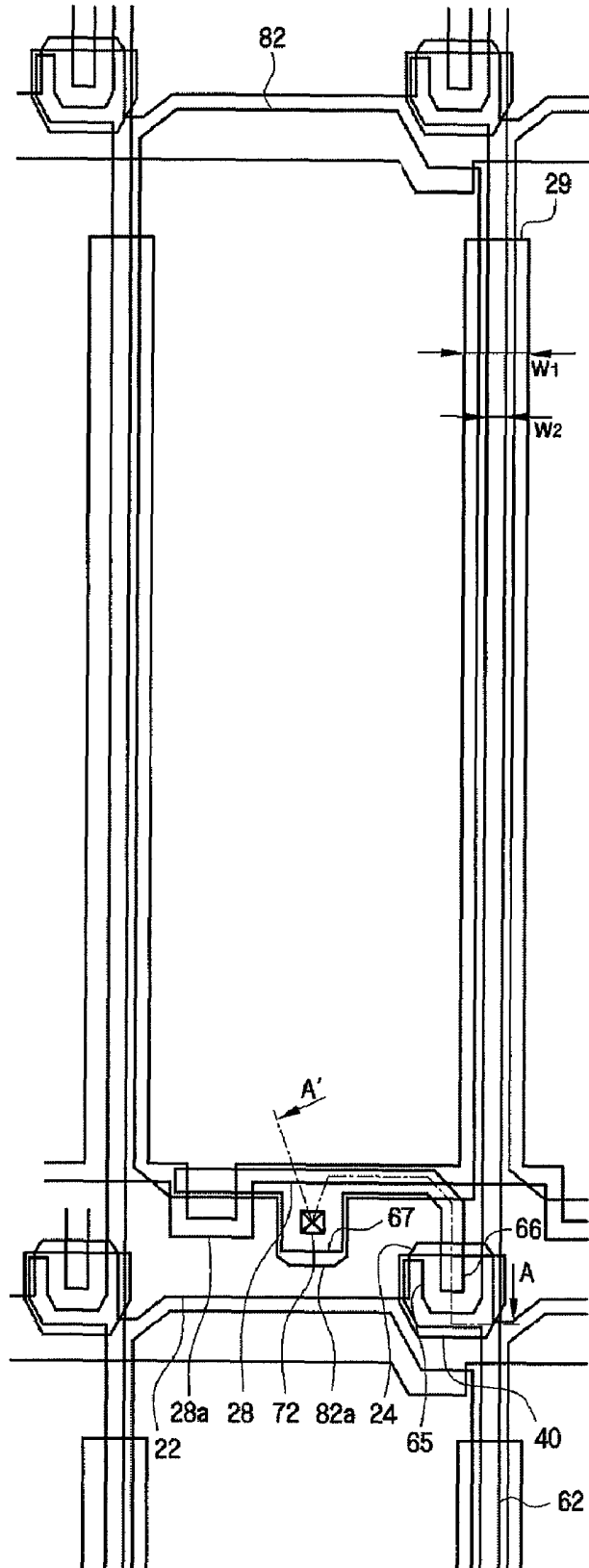

FIG. 2

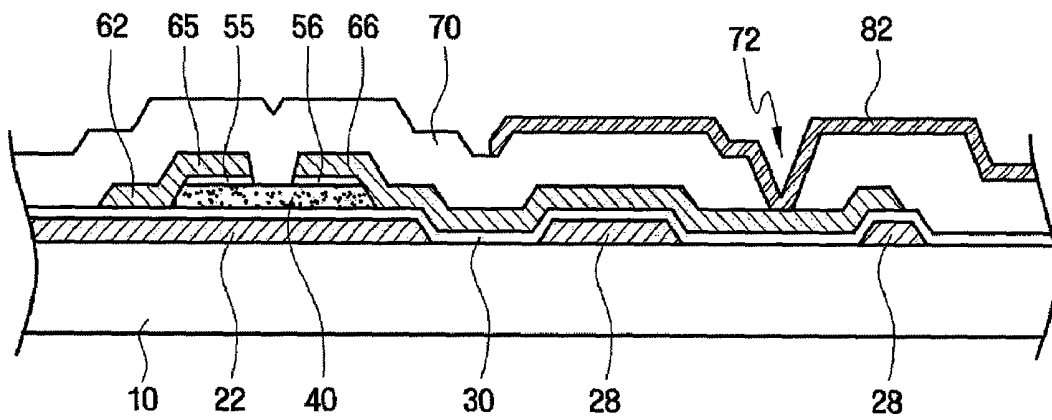

FIG. 3

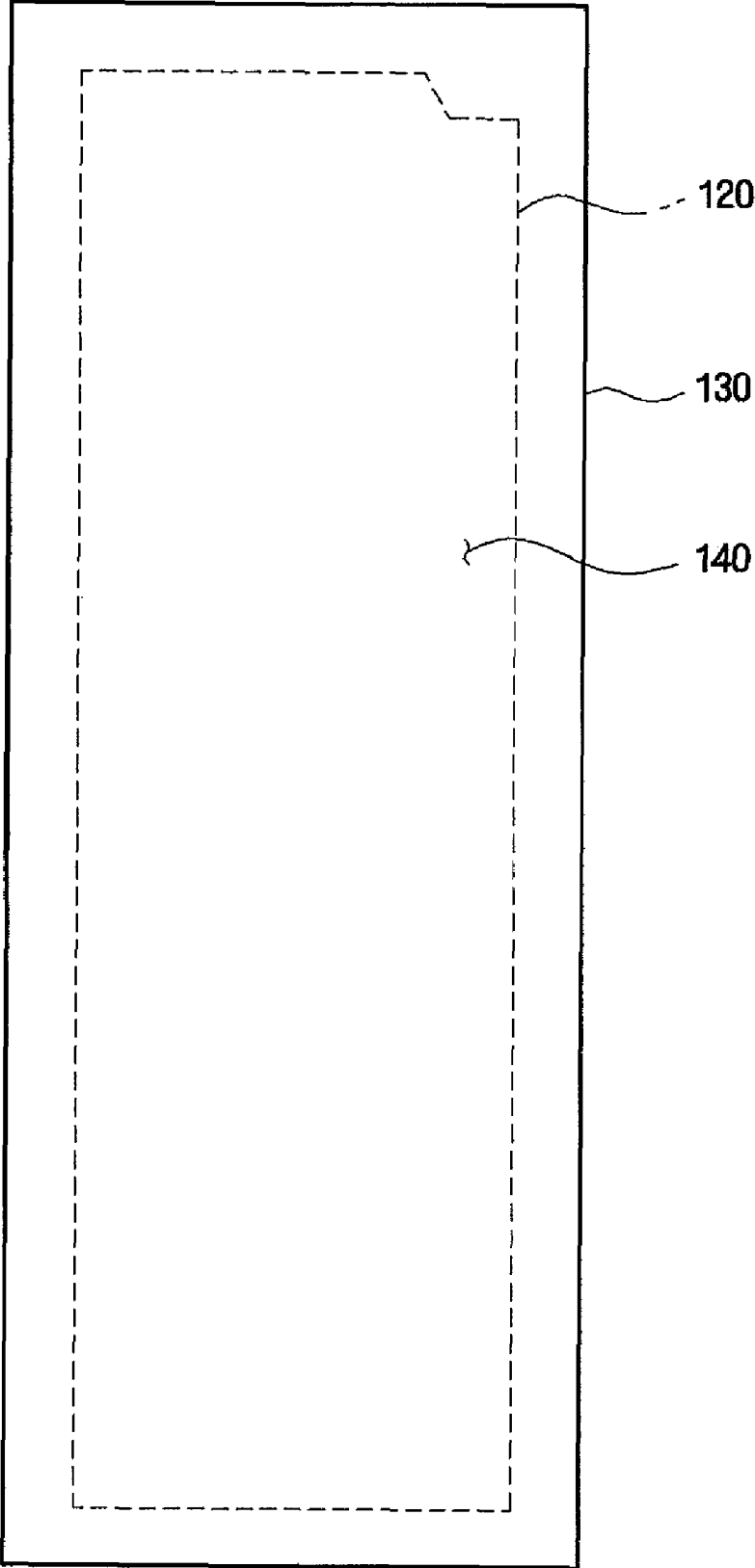

FIG. 4

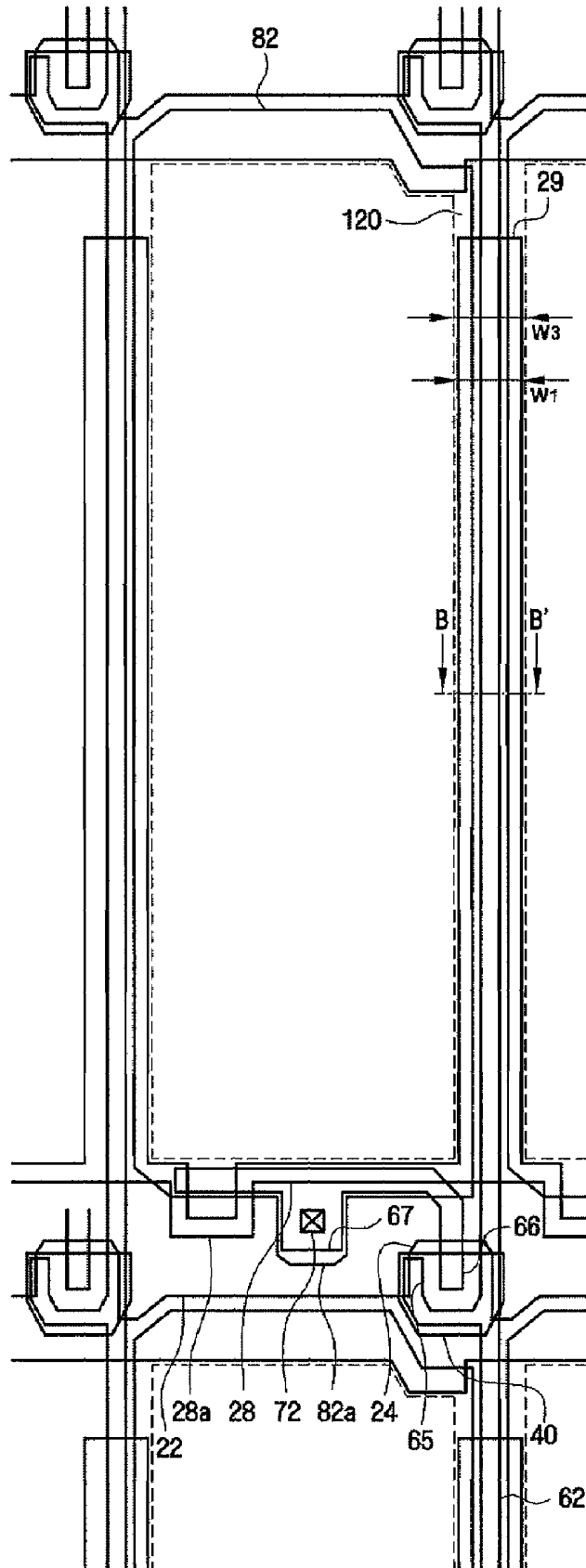

FIG. 5

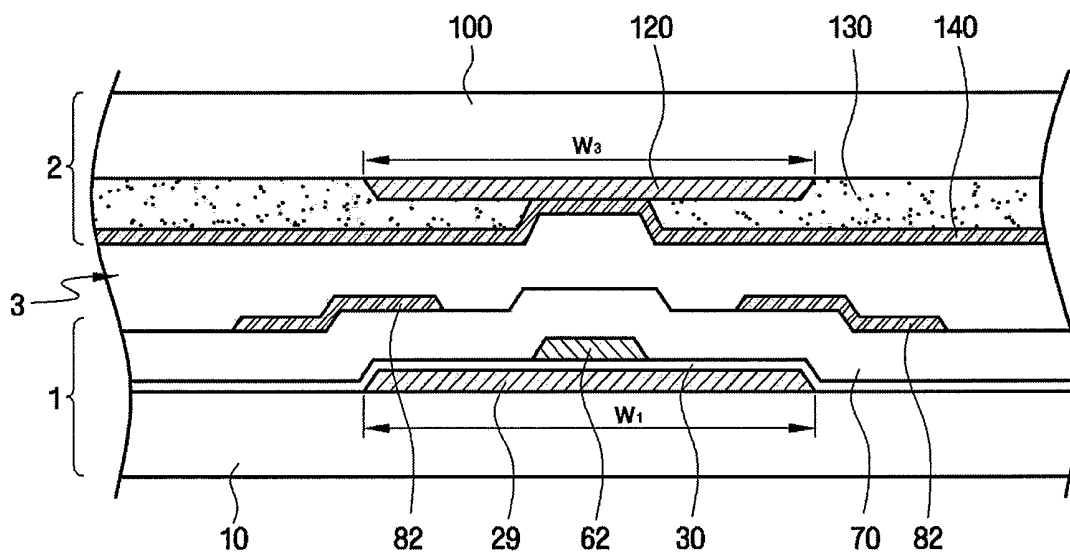



FIG. 7

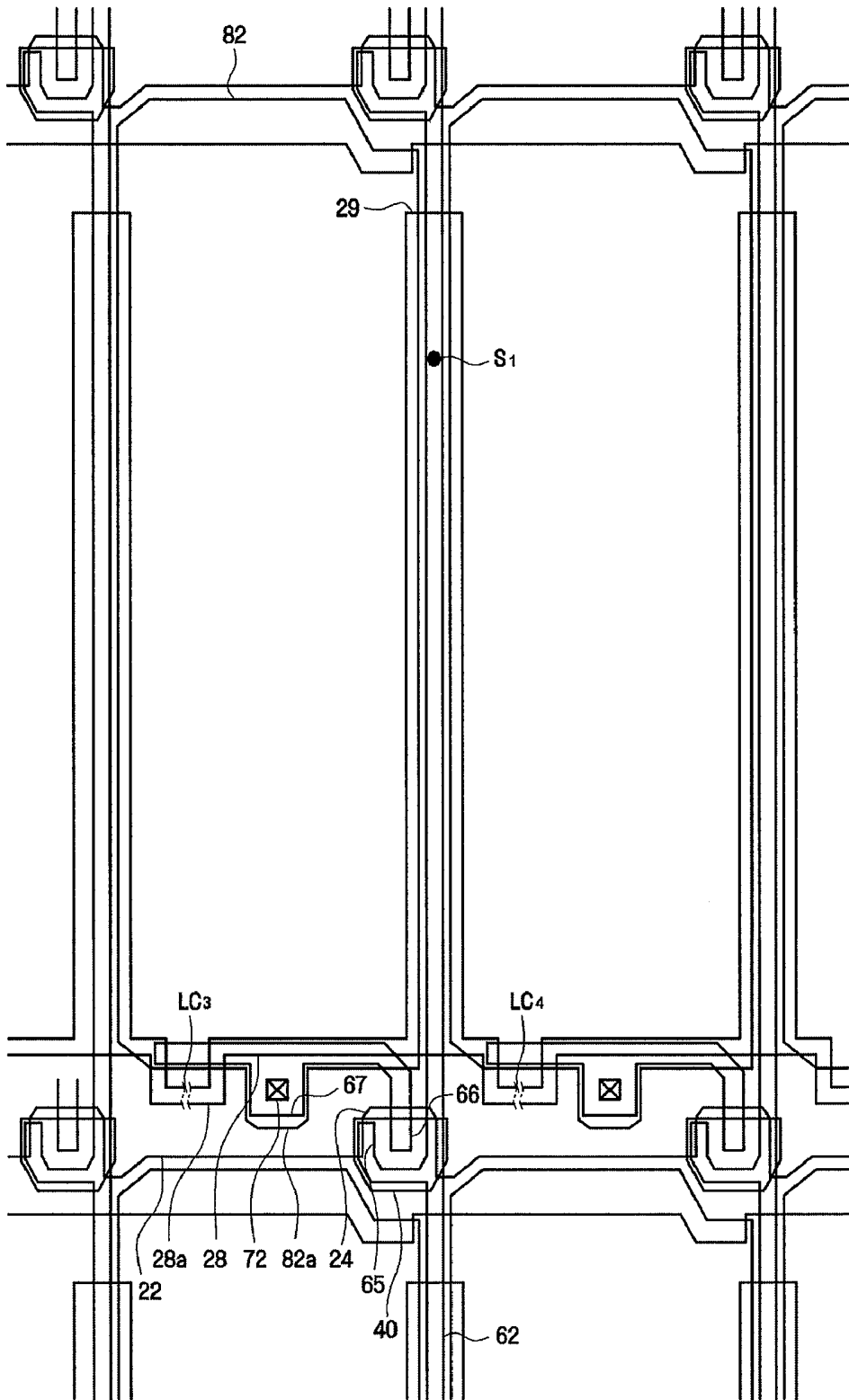

FIG. 8

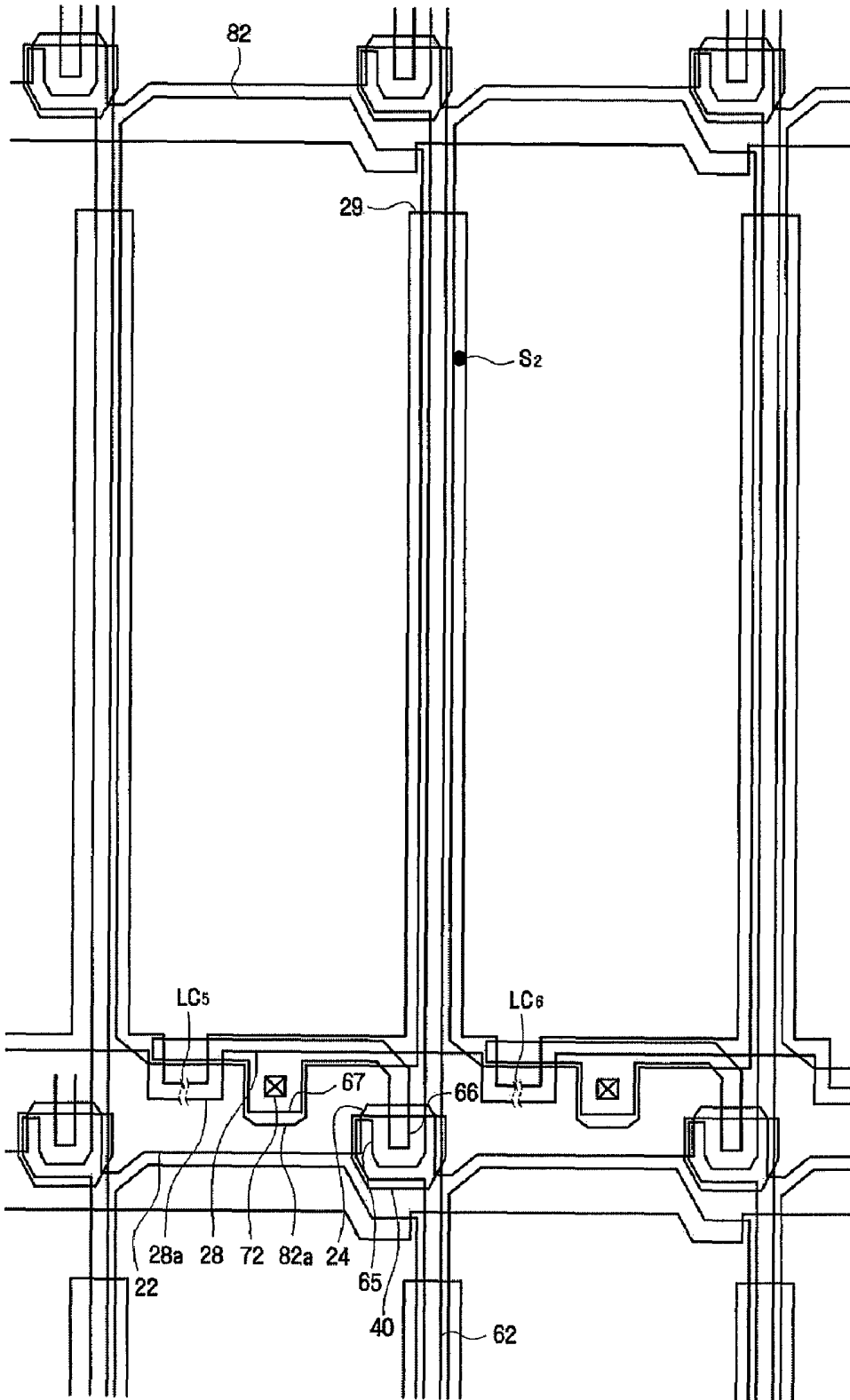

FIG. 9

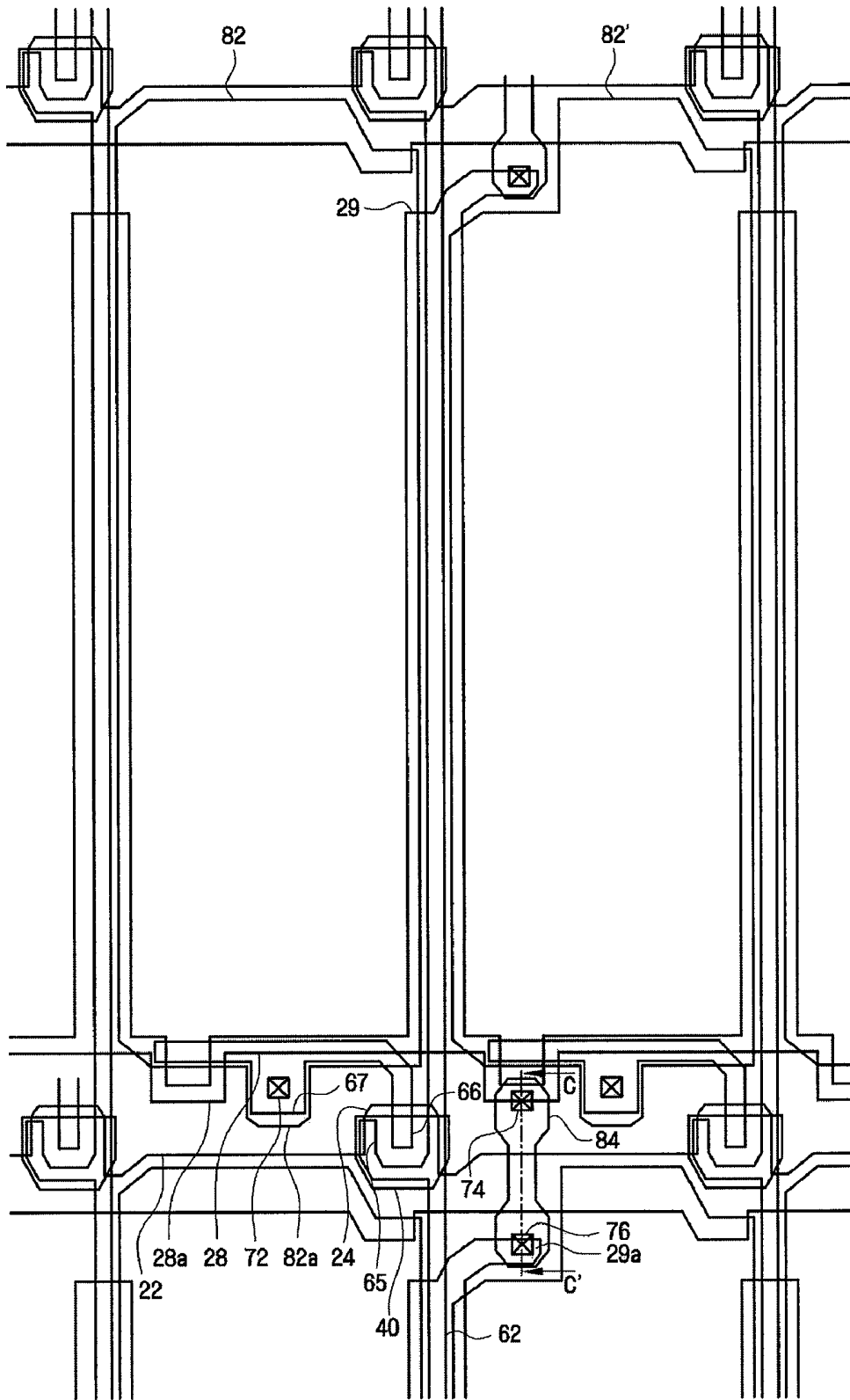

FIG. 10

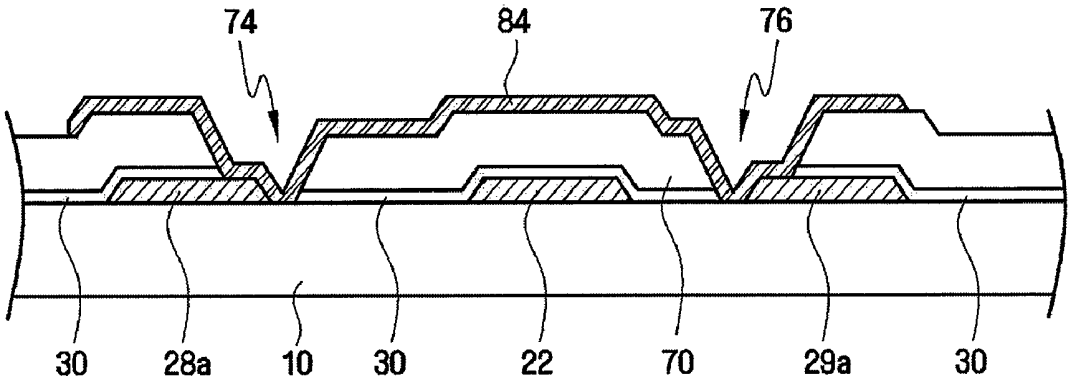

FIG. 11

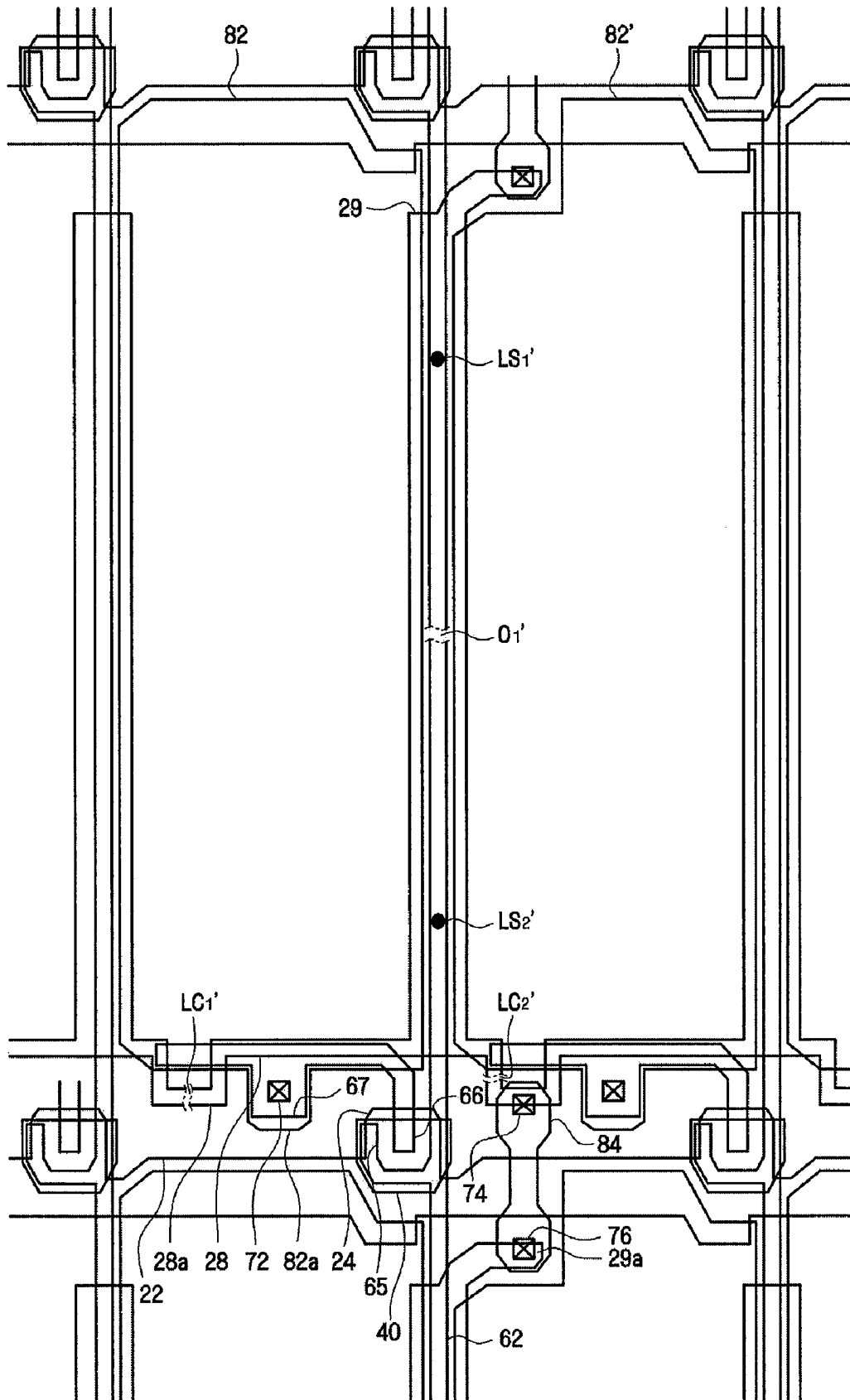

FIG. 12

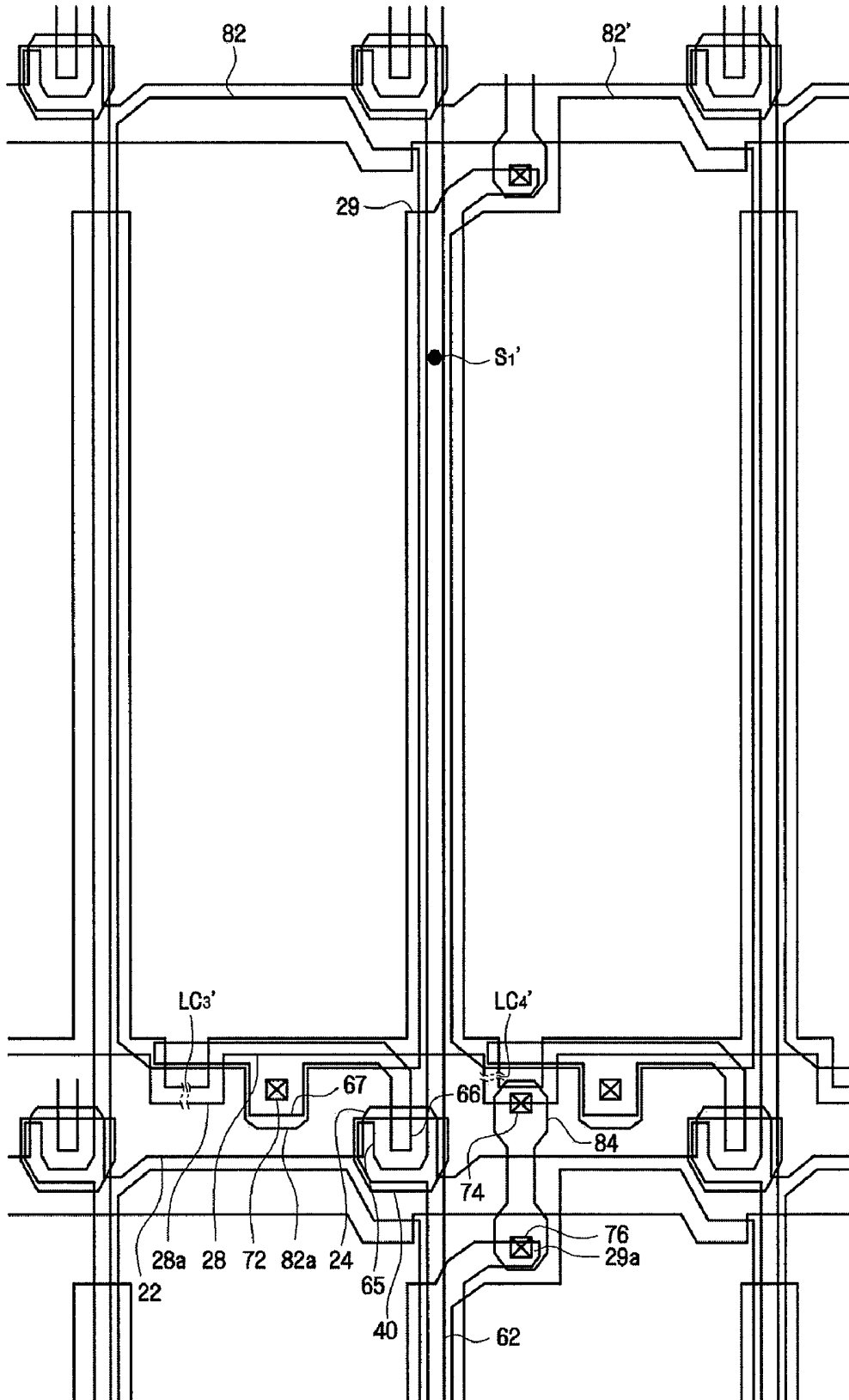

FIG. 13

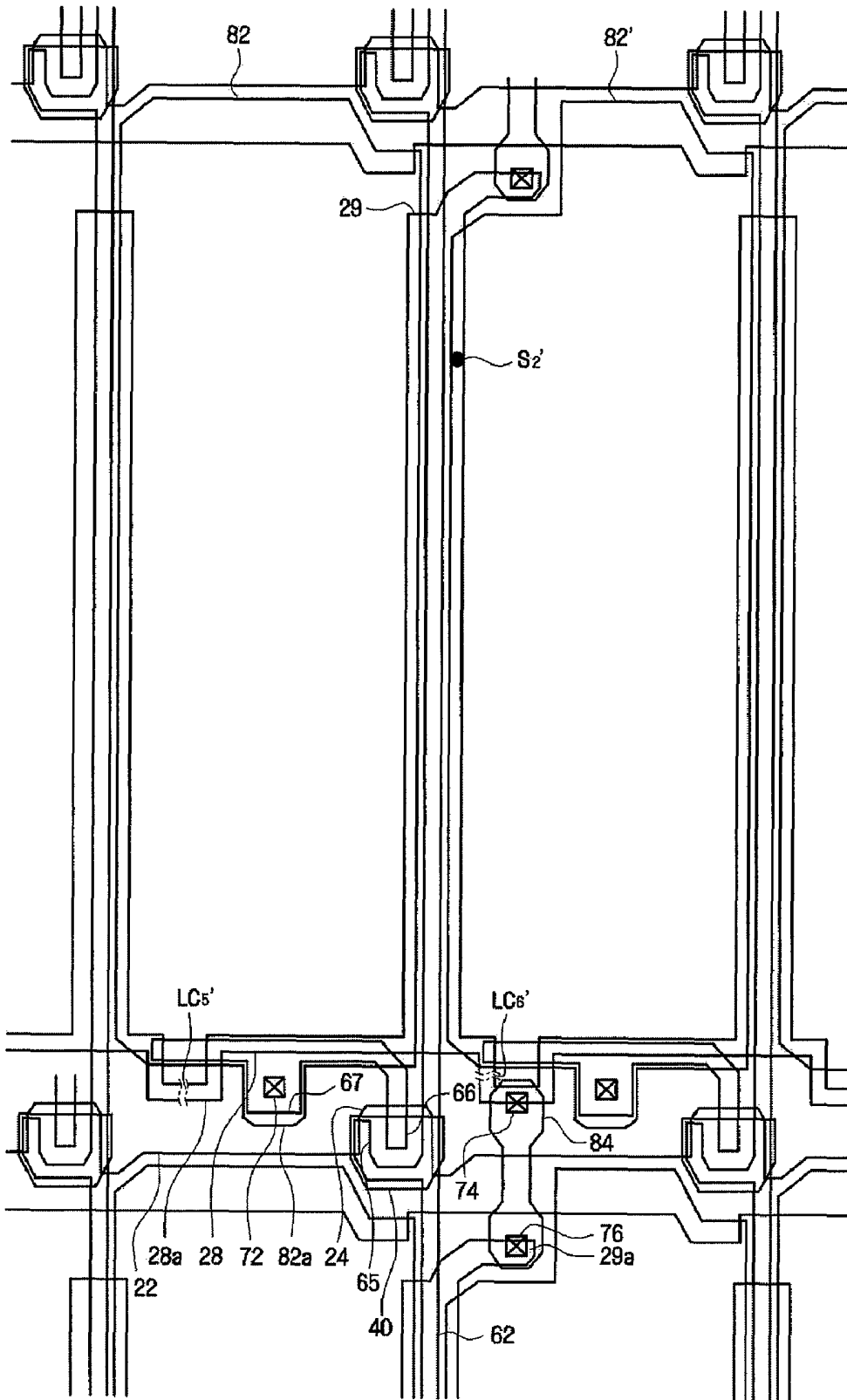
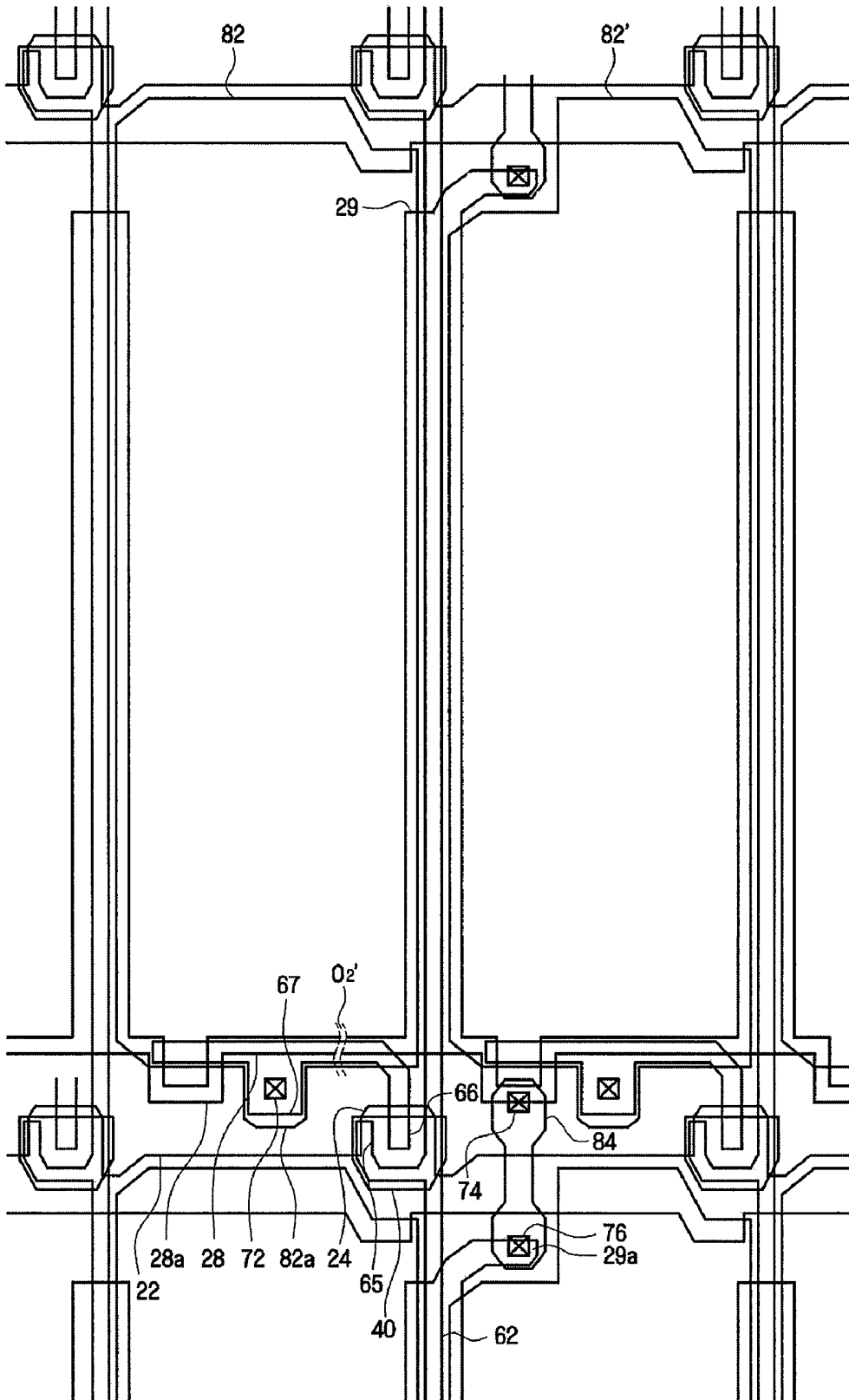

FIG. 14



# LIQUID CRYSTAL DISPLAY DEVICE AND METHOD OF REPAIRING BAD PIXELS THEREIN

## CROSS REFERENCE TO RELATED APPLICATION

This application claims priority from Korean Patent Application No. 10-2006-0108410 filed on Nov. 3, 2006, in the Korean Intellectual Property Office, the disclosure of which is incorporated herein by reference in its entirety.

## BACKGROUND OF THE INVENTION

### 1. Field of the Invention

The present invention relates to an image display device and, more particularly, to a liquid crystal display device and a method of repairing bad pixels therein.

### 2. Description of the Prior Art

The cathode ray tube (CRT), liquid crystal display (LCD), plasma display panel (PDP) apparatus, electronic paper display (EPD), and so forth are examples of commonly used image display devices that are being developed to the meet demand for miniaturization, weight reduction, and low power consumption.

A liquid crystal display includes a color filter substrate having a color filter, a thin film transistor ("TFT") substrate having a TFT array, and a liquid crystal layer interposed between the color filter substrate and the TFT substrate.

The TFT substrate of the LCD includes a plurality of gate lines, a plurality of storage wirings, a plurality of data lines, a pixel electrode and others. There is a concern that an open may occur in the individual wirings or a that a short between the wirings may occur. If one data line is opened, all pixels in a column connected to that data line will not operate.

When pixel defects occur, a process of repairing the pixel defects is generally performed, but the process may give rise to further pixel defects, for example, a short between wirings overlapping each other. As such, a method is needed that efficiently and easily repairs bad pixels without causing any other pixel defects.

## SUMMARY OF THE INVENTION

Accordingly, to an aspect of the present invention an exemplary embodiment provides an LCD device where bad pixels to be efficiently and easily repaired.

The exemplary embodiments of the present invention further provide a method of repairing bad pixels in such an LCD device.

In an exemplary embodiment a liquid crystal display device includes: a first insulating substrate; a gate wiring and a storage wiring arranged substantially parallel to each other in a first direction on the first insulating substrate; a data wiring intersecting the gate and storage wirings in an insulated manner, and arranged substantially in a second direction; and a pixel electrode formed on a pixel area defined by the gate and data wirings, wherein the storage wiring includes a horizontal portion arranged substantially in the first direction and at least a part of which does not overlap the pixel electrode, and a vertical portion branching off substantially in the second direction from the horizontal portion and overlapping the data wiring.

In accordance with another exemplary embodiment, a method of repairing bad pixels of a liquid crystal display device comprises: providing the thin film transistor substrate having gate wiring and a storage wiring arranged substan-

tially parallel to each other in a first direction on an insulating substrate, data wiring intersecting but insulated from the gate and storage wirings and arranged substantially in a second direction, a pixel electrode formed on a pixel area defined by the gate and data wirings,

wherein the storage wiring comprises a horizontal portion arranged substantially in the first direction and at least a part of which does not overlap the pixel electrode, and a vertical portion branching off substantially in the second direction from the horizontal portion and overlapping the data wiring; and cutting the storage wiring by irradiating a laser beam onto a part of the horizontal portion that does not overlap the pixel electrode.

## BRIEF DESCRIPTION OF THE DRAWINGS

The above and other objects, features and advantages of the present invention will be apparent from the following detailed description taken in conjunction with the accompanying drawings, in which:

FIG. 1 is a layout view of a TFT substrate included in an LCD device in accordance with a first preferred embodiment of the present invention;

FIG. 2 is a sectional view taken along line A-A' of FIG. 1;

FIG. 3 is a layout view of a color filter substrate included in the LCD device in accordance with the first preferred embodiment of the present invention;

FIG. 4 is a layout view of the LCD device in accordance with the first preferred embodiment of the present invention;

FIG. 5 is a sectional view taken along line B-B' of FIG. 4;

FIG. 6 is a view schematically illustrating a method of repairing an open when an open occurs in a data line of the TFT substrate of FIG. 1;

FIG. 7 is a view schematically illustrating a method of repairing a short when the short occurs in a data line of the TFT substrate of FIG. 1;

FIG. 8 is view schematically illustrating a method of repairing a short when the short occurs in a pixel electrode of the TFT substrate of FIG. 1;

FIG. 9 is a layout view of a TFT substrate included in an LCD device in accordance with a second preferred embodiment of the present invention;

FIG. 10 is a sectional view taken along line C-C' of FIG. 9;

FIG. 11 is a view schematically illustrating a method of repairing an open when the open occurs in a data line of the TFT substrate of FIG. 9;

FIG. 12 is a view schematically illustrating a method of repairing a short when the short occurs in a data line of the TFT substrate of FIG. 9;

FIG. 13 is view schematically illustrating a method of repairing a short when the short occurs in a pixel electrode of the TFT substrate of FIG. 9; and

FIG. 14 is a view schematically illustrating how a bridge electrode functions when a short occurs in a storage wiring of the TFT substrate of FIG. 9.

## DETAILED DESCRIPTION OF THE EXEMPLARY EMBODIMENTS

It should be noted that the term "on", as mentioned herein, is used not only in the case where elements or layers are directly on other elements or layers, but also in the case where other intermediate elements or layers intervene therebetween. In contrast, the term "directly on", as mentioned herein, means that elements or layers are on other elements or layers without any other intermediate elements or layers

intervening therebetween. Like numbers designate like elements throughout the specification and drawings.

Spatially relative terms such as “below”, “beneath”, “lower”, “above” and “upper” may be used herein for easily describing correlations between one element or constituents and other elements or constituents, as illustrated in the figures. It should be appreciated that the spatially relative terms are intended to encompass different orientations of the element in use or operation in addition to the orientation depicted in the figures. Like numbers designate like elements throughout the specification and drawings.

Reference will now be made to a first preferred embodiment of the present invention with reference to FIGS. 1 to 5. FIG. 1 illustrates the layout of a TFT substrate included in an LCD device according to the first embodiment of the present invention. FIG. 2 illustrates a section taken along line A-A' of FIG. 1. FIG. 2 illustrates the layout of a color filter substrate included in the LCD device according to the first embodiment of the present invention. Finally, FIG. 5 illustrates a section taken along line B-B' of FIG. 4.

As illustrated in FIGS. 4 and 5, the LCD device according to the first embodiment of the present invention includes a TFT substrate, a color filter substrate opposite thereto, and a liquid crystal layer 3 formed between these two substrates, and oriented in a certain direction.

First, a detailed description of the TFT substrate will be given with reference to FIGS. 1 and 2.

The TFT substrate according to the first embodiment of the present invention includes a gate wiring 22 and 24, a storage wiring 28 and 29, a gate insulating film 30, an active layer 40, an ohmic contact layer 55, 56, a data wiring 62, 65, 66, and 67, a protective film 70, a pixel electrode 82 and the like, all of which are formed on a first insulating substrate 10.

The first insulation substrate 10 may be made of heat-resistant, optically transparent material such as transparent glass or plastic.

The gate wiring 22 and 24 and the storage wiring 28 and 29 are formed on the first insulating substrate 10, and are arranged substantially parallel to each other in a first direction. The gate wiring 22 and 24 and the storage wiring 28 and 29 may be formed on the same layer, for example, on the first insulating layer 10.

The gate wiring 22 and 24 includes a gate line 22 and a gate electrode 24. The gate line 22 is arranged substantially in the first direction, for example, in a transverse direction, and transmits a gate signal. The gate electrode 24 projects from the gate line 22 in the form of a protrusion and constitutes three terminals of a TFT, together with a source electrode 65 and a drain electrode 66, as will be described below.

The storage wiring 28 and 29 includes a horizontal portion 28 and a vertical portion 29. The horizontal portion is arranged substantially parallel to the gate wiring 22 and 24 in the first direction. The vertical portion 29 branches off substantially in a second direction and overlaps the data wiring 62, 65, 66, and 67, as will be described below.

A storage voltage is applied to the storage wiring 28 and 29, which forms a storage capacitor together with the pixel electrode 82, as will be described below. In accordance with an aspect of the invention, the storage wiring 28 and 29 also functions to repair pixel defects.

The horizontal portion 28 is arranged parallel to and spaced from the gate wiring 22 and 24, and in particular, the gate line 22. The horizontal portion 28 is disposed to overlap the pixel electrode 82, as will be described below, and thus the storage capacitor is formed between the pixel electrode 82 and the horizontal portion 28.

At least apart of the horizontal portion 28 does not overlap the pixel electrode 82. Specifically, the horizontal portion 28 is generally parallel to the gate line 22, but a bent portion 28a projecting beyond an edge of the pixel electrode 82 is formed in a part of the horizontal portion 28 such that the part of the horizontal portion 28 does not overlap the pixel electrode 82. The bent portion 28a is bent toward the gate line 24 adjacent to the horizontal portion 28, but does not overlap the gate wiring 22 and 24, and the data wiring 62, 65, 66, and 67. Although the bent portion 28a is U-shaped in the present embodiment, it may take other shapes such as a circular arc shape, a ridge shape, and others, so long as it does not overlap the pixel electrode 82. Various modifications may be made to its shape. In this way, since the storage wiring 22, 24 includes the bent portion 28a not overlapping the pixel electrode 82, it is possible to efficiently repair an open or a short when the open or the short occurs in the data line 62 and the pixel electrode. Such a method of repairing bad pixels of the LCD device will be described in detail in the following.

From the above-mentioned horizontal portion 28, the vertical portion 29 branches off substantially in a second direction, for example, in a longitudinal direction. Specifically, the horizontal portion 28 may be arranged parallel to and along the long side of the TFT substrate in a transverse direction, and a plurality of vertical portions 29 may branch off from each horizontal portion 28 and be arranged parallel to the short side of the TFT substrate in a longitudinal direction.

The vertical portion 29 branches off from the horizontal portion 28, and is formed in such a manner that the distal end of the vertical portion 29 adjoins the gate line 22 of an adjacent pixel, but is spaced from the gate line 22 of the adjacent pixel such that it is not electrically connected thereto.

The vertical portion 29 overlaps the data line 62 as will be described below, and is used for repairing an open or a short of the data line 62. A description thereof will also be given to explain a method of repairing bad pixels of the LCD device according to the present embodiment.

The vertical portion 29 is so formed as to have a wider width  $W_1$  than the width  $W_2$  of the data line 62, which facilitates repair of the data line 62. Edges of the vertical portion 29 overlap the pixel electrode 82 along the second direction, for example, along a longitudinal direction, thereby preventing light emitted from a backlight assembly (not shown) from leaking. That is, the vertical portion 29 overlaps a pair of pixel electrodes 82 adjacent to each other. Further, referring to FIG. 3, the vertical portion 29 has the same width  $W_1$  as the width  $W_3$  of a black matrix 120, so as not to reduce an aperture ratio.

Referring to FIGS. 1 and 2 again, the gate wiring 22 and 24 and the storage wiring 28, 29 may be made of an aluminum-based metal such as aluminum (Al) or an aluminum alloy, a silver-based metal such as silver (Ag) or a silver alloy, a copper-based metal such as copper (Cu) or a copper alloy, a molybdenum-based metal such as molybdenum (Mo) and a molybdenum alloy, chrome (Cr), titanium (Ti), Tantalum (Ta) or the like. Further, the gate wiring 22 and 24 and the storage wiring 28 and 29 may have a multilayer structure including two electrically conductive layers (not shown) which have different physical properties. In addition, the gate wiring 22 and 24 and the storage wiring 28 and 29 may be formed by applying PEDOT (PolyEthyleneDiOxyThiophene), which is an electrically conductive organic polymer material, in a coating method, or by printing the same using an inject-printing method.

The gate insulating film 30, made of inorganic insulating material such as silicone oxide (SiOx) or silicone nitride (SiNx), or organic insulating material such as BCB (Benzo-

CycloButene), acrylic material or polyamide, covers the gate wiring **22** and **24** and the storage wiring **28** and **29** on the first insulating substrate **1**.

The active layer **40**, made of hydrogenated amorphous silicone, polycrystalline silicone or electrically conductive organic material, is partially formed in an upper portion of the gate insulating film **30**.

The active layer **40** may have various shapes including an island shape and a linear shape. For example, when the active layer **40** is formed in the shape of an island as in the present embodiment, it overlaps the gate electrode **24** on the gate electrode **24** and at least partially overlaps the source electrode **65** and the drain electrode **66**, as will be described below. The shape of the active layer **40** is not limited to an island shape, but can be many shapes. When the active layer is formed in a linear shape, it is positioned underneath the data line **62** and may have a shape extending up to above the gate electrode **24**.

The ohmic contact layers **55**, **56** may be formed on the active layer **40**. The ohmic contact layers **55**, **56** are made of n+ hydrogenated amorphous silicone highly doped with n-type impurities, ITO material doped with p-type impurities, or others. The ohmic contact layers **55**, **56** are positioned in pairs on the active layer **40**, thereby improving a contact characteristic between the active layer **40** and the source and drain electrodes **65**, **66** as will be described below. When the contact characteristic between the active layer **40** and the source and drain electrodes **65**, **66** formed thereon is good, the ohmic contact layers **55**, **56** may be omitted.

The data wiring **62**, **65**, **66**, and **67** are formed on the active layer **40** and the gate insulating film **30**. The data wiring **62**, **65**, **66**, and **67** is arranged substantially in the second direction, for example, in a longitudinal direction. The data wiring **62**, **65**, **66**, and **67** includes a data line **62** intersecting the gate line **22** in an insulated manner to thereby define a pixel, the source electrode **65** branching off from the data line **62** and extending up to above the active layer **40**, and the drain electrode **66** separated from and facing the source electrode **65**.

The data line **62** is arranged in a longitudinal direction, intersects the gate line **22**, and is applied with a data signal.

The source electrode **65** may branch off from the data line **62** along a J-shaped path, and at least partially overlaps the active layer **40**.

One end of the drain electrode **66** is positioned in a recessed portion of the J-shaped source electrode **65** and at least partially overlaps the active layer **40**.

An enlarged drain electrode portion **67**, formed wider than the drain electrode **66**, extends from one end of the drain electrode **66**, and is electrically connected to the pixel electrode **82**. The enlarged drain electrode portion **67** is formed outside of a pixel area so as not to reduce an aperture ratio. In order to minimize the aperture ratio, a region extending from one end of the drain electrode **66** to the enlarged drain electrode portion **67** is formed in a linear shape and overlaps the horizontal portion **28** of the storage wiring **28** and **29**. The pixel area refers to an area defined by the gate wiring **22** and **24** and the data wiring **62**, **65**, **66**, and **67**. The pixel area may be understood as an area through which light emitted from the backlight assembly passes. Thus, the color filter area (see reference numeral "130" in FIG. 3) of the color filter substrate (see reference numeral "2" in FIG. 5), which corresponds to the pixel area of the TFT substrate, may also be understood as a pixel area.

The data wiring **62**, **65**, **66**, and **67** may be made of a refractory metal such as chrome, a molybdenum-based metal, tantalum and titanium, and may also have a multilayer struc-

ture consisting of, for example, a lower layer (not shown), which is formed of the refractory metal or the like, and an upper layer (not shown), which is formed of a low-resistivity material and located on the lower layer. An example of the multilayer structure includes a double layer of a lower chrome layer and an upper aluminum layer or a lower aluminum layer and an upper molybdenum layer, and a triple layer of molybdenum-aluminum-molybdenum layers.

The protective film **70** is formed on the data line **62**, the drain electrode **66** and an exposed semiconductor layer **40**. The protective film **70** is made of an inorganic material consisting of silicone nitride or silicone oxide, an organic photosensitive material having a good planarization characteristic, a low-dielectric insulating material such as a-Si:C:O and a-Si:O:F formed by plasma enhanced chemical vapor deposition (PECVD), or others. Further, the protective film **70** may have a double layer structure of a lower inorganic layer and an upper organic layer in order to make the most of superior characteristics of the organic layer, and simultaneously protect the exposed semiconductor layer **40**.

The protective film **70** is formed with a contact hole **72** through which the enlarged drain electrode portion **67** is exposed.

The pixel electrode **82** is formed on the protective film **70**, and is electrically connected to the drain electrode **66** through the contact hole **72**. A drain-electrodes-connecting portion **82a** is formed on one side of the pixel electrode **82**. This portion **82a** is electrically connected to the drain electrode **66**, in particular, to the enlarged drain electrode portion **67** through the contact hole **72**, and a data voltage is applied thereto via the drain electrode **66**. In order not to reduce the aperture ratio, the drain-electrode-connecting portion **82a** may project outside of the pixel area through which light emitted from the backlight assembly passes.

The pixel electrode **82** may be made of a transparent, electrically conductive material such as ITO (Indium Tin Oxide) or IZO (Indium Zinc Oxide), or a reflective, electrically conductive material such as aluminum.

Referring to FIGS. 4 and 5, when a data voltage is applied to the pixel electrode **82**, the pixel electrode **82**, together with a common electrode **140** of the color filter substrate, generates an electric field, thereby determining the orientation of liquid crystal molecules of the liquid crystal layer **3**.

Reference will now be made to the color filter substrate included in the LCD device according to the present embodiment with reference to FIGS. 3 to 5.

The color filter substrate includes a black matrix **120**, a color filter **130**, an overcoat film (not shown), a common electrode **140**, and others, all of which are formed on the lower surface of a second insulating substrate **100**, and is disposed to face the TFT substrate.

The second insulating substrate **100** of the color filter substrate may be made of heat-resistant, optically transparent material such as transparent glass or plastic.

The black matrix **120**, made of an opaque material such as chrome, is formed on the insulating substrate according to the present embodiment to partition a pixel area.

The black matrix **120** is arranged in the shape of a matrix along first and second directions, and its width  $W_3$  in the second direction, for example, in a longitudinal direction, is substantially the same as that of the vertical portion **29** of the storage wiring **28** and **29**, as stated above.

The pixel area partitioned by the black matrix **120** is successively formed of red, green and blue color filters **130**. The color filters **130** are made of materials transmissive to light of different colors, and thus functions to transmit therethrough light of a specific wavelength band.

The color filters **130** may be disposed in a stripe, mosaic or delta pattern, but stripe-patterned color filters **130** will be described by way of example in the present embodiment. In the stripe-patterned color filters **130**, color filters of the same color are disposed in the second direction, for example, in a longitudinal direction. That is, viewed in the first direction, for example, in a transverse direction, an  $n$ th ( $n$  is an integer) color filter may be a red color filter, an  $(n+1)$ th color filter may be a green color filter, and an  $(n+2)$ th color filter may be a blue color filter.

The overcoat film is formed on the color filters **130**. The common electrode **140**, made of transparent, electrically conductive material such as ITO or IZO, is formed on the overcoat film. Further, although not shown in the drawings, a spacer for providing a definite gap between the common electrode **140** and the TFT substrate may be formed on the pixel electrode **82**, and the gap left by the spacer is filled with the liquid crystal layer **3**.

Reference will now be made in detail to a method of repairing bad pixels when pixel defects occur in the LCD device, with reference to FIGS. **6** to **8**. FIG. **6** schematically illustrates a method of repairing an open when the open occurs in the data line of the TFT substrate in FIG. **1**, FIG. **7** schematically illustrates a method of repairing a short when the short occurs in the data line of the TFT substrate in FIG. **1**, and FIG. **8** schematically illustrates a method of repairing a short when the short occurs in the pixel electrode of the TFT substrate in FIG. **1**.

Since the TFT substrate includes a plurality of wirings and a plurality of electrodes, an open may occur in the individual wirings and electrodes or a short may occur between the wirings or between the wirings and the electrodes.

Specifically, if an open region  $O_1$  occurs in the data line **62**, all pixels connected to the opened data line **62** will not operate.

In order to repair such pixel defects, a laser beam is irradiated through the data line **62** and the storage wiring **28** and **29** corresponding to both sides of the open region  $O_1$  to thereby form laser short regions  $LS_1$  and  $LS_2$ . The laser beam forms the laser short regions  $LS_1$  and  $LS_2$  by partially melting the data line **62** and the storage wiring **28** and **29**, and thus the data line **62** and the storage wiring **28** and **29** are electrically connected to each other. As a result of this, a signal applied through the data line **62** does not pass through the open region  $O_1$ , but a separate current path, that is, a bypass to the vertical portion **29** of the storage wiring **28** and **29** via the laser short regions  $LS_1$  and  $LS_2$ , is formed, so that bad pixels can be easily repaired. For example, a laser beam belonging to a green wavelength band (about 532 nm) may be used in repairing the pixel defects, and a laser beam with a power of 0.1 to 1 mJ may be applied for melting the data line **62** and the vertical portion **29** of the storage wiring **28** and **29**. The diameter of the laser beam spot may be ranged from 1 to 4  $\mu\text{m}$ , for example.

However, if only the above-mentioned method step is performed, a data signal applied through the data line **62** is transferred to the storage wiring **28** and **29**, and thus interferes with a storage voltage signal applied to the storage wiring **28** and **29**, which may have a negative influence on other good pixels. Thus, it is preferable to cut the storage wiring **28** and **29** of the corresponding bad pixel. Specifically, a laser beam is irradiated onto a part not overlapping the pixel electrode **82**, that is, the bent portion **28a**, of the horizontal portion **28** of the storage wiring **28** and **29** to thereby form laser cut regions  $LC_1$  and  $LC_2$ , and thus the storage wiring **28** and **29** is cut. Here, all the bent portions **28a** of pixel areas adjacent to both sides of the cut data line **62** are formed with the laser cut

regions  $LC_1$  and  $LC_2$ . That is, when one data line **62** is opened, the laser cut regions  $LC_1$  and  $LC_2$ , are formed in two bent portions **28a** positioned on both sides of the cut data line **62**. By cutting the part not overlapping the pixel electrode **82**, that is, the bent portion **28a**, it is possible to prevent signal interference with other pixels, which may arise in the bad-pixel repair process.

In the present embodiment, by using a laser beam and providing the storage wiring **28** and **29** with the bent portion **28a** not overlapping the pixel electrode **82**, the above-mentioned signal interference due to a short between the data line **62** and the source electrode **65** positioned thereunder or a further short of the very thin data line **62** can be prevented, as compared to a case where, in order to repair the open data line **62**, open portions of the data line **62** are connected to each other by using CVD.

As illustrated in FIG. **7**, since the overlapping area between the data line **62** and the storage electrode **82** is large, they are highly likely to be shorted by particles, etc. If a short region  $S_1$  occurs between the data line **62** and the storage wiring **28** and **29**, all storage wiring **28** and **29** connected to the shorted data line **62** are attacked by the above-mentioned signal interference, which results in pixel defects.

In such a case, since the horizontal portion **28** of the storage wiring **28** and **29** is formed with the bent portion **28a** projecting beyond an edge of the pixel electrode, laser cut regions  $LC_3$  and  $LC_4$  can be formed in the bent portions **28a** of pixel areas adjacent to both sides of the shorted data line **62**. That is, when one data line **62** is shorted, laser cut regions  $LC_3$  and  $LC_4$  are formed in two bent portions **28a**, positioned on both sides of the shorted data line **62**, respectively, thereby preventing signal interference from occurring in the storage wiring **28** and **29** and the data wiring **62**, **65**, **66**, and **67**.

In this way, when a short occurs between the data line **62** and the vertical portion **29** of the storage wiring **28** and **29**, the TFT substrate according to the present embodiment enables the laser cut regions  $LC_3$  and  $LC_4$  to be easily formed in the horizontal portion **28** of the storage wiring **28** and **29**, which adjoins the short region  $S_1$ , because the storage wiring **28** and **29** is formed with the bent portion **28a** projecting beyond an edge of the pixel electrode **82**. Consequently, pixel defects caused by the shorted data line can be easily repaired.

As illustrated in FIG. **8**, if a short region  $S_2$  occurs between the storage wiring **28** and **29** and the pixel electrode **82** by particles, etc., an undesired storage voltage is applied to the pixel electrode **82**, resulting in pixel defects.

In such a case, since the horizontal portion **28** of the storage wiring **28** and **29** is formed with the bent portion **28a** projecting beyond an edge of the pixel electrode, laser cut regions  $LC_5$  and  $LC_6$  can be formed in the bent portions **28a** of pixel areas adjacent to both sides of the shorted storage wiring **28** and **29**. That is, when one storage wire is shorted, laser cut regions  $LC_5$  and  $LC_6$  are formed in two bent portions **28a**, positioned on both sides of the shorted data line **62**, respectively. Thus, all pixels connected to the shorted storage wiring **28** and **29** can be prevented from suffering from pixel defects.

In the TFT substrate according to the present embodiment, when a short occurs between the pixel electrode **82** and the storage wiring **28** and **29**, the laser cut regions  $LC_5$  and  $LC_6$  can be easily formed in the storage wiring **28** and **29** because the storage wiring **28** and **29** is formed with the bent portion **28a** projecting beyond an edge of the pixel electrode **82**. Consequently, all pixels connected to the shorted storage wiring **28** and **29** can be prevented from suffering from pixel defects. In such a bad-pixel-repair method, bad pixels can be repaired without turning off the bad pixels by irradiating a

laser beam onto the defective pixel electrode **82** to generate a short between the pixel electrode **82** and the gate line **22**.

Reference will now be made in detail to a second preferred embodiment of the present invention with reference to FIGS. **9** and **10**. FIG. **9** illustrates the layout of a TFT substrate included in an LCD device according to the second embodiment, and FIG. **10** illustrates a section taken along line B-B' of FIG. **9**.

For explanatory convenience, the same functional constituents as those illustrated in the drawings of the previous embodiment are designated by the same reference numerals, and thus a description thereof is brief or omitted. As illustrated in FIGS. **9** and **10**, the LCD device according to the present embodiment has essentially the same structure as that of the LCD device according to the previous embodiment of the present invention, except that the LCD device according to the present embodiment further includes a bridge electrode **84** connecting the storage wiring **28** and **29** of adjacent pixels to each other.

In the present embodiment, a projection portion **29a** is formed at the distal end of the vertical portion **29** of the storage wiring **28** and **29**. The projection portion **29a** projects toward the pixel electrode **82'** and thus is positioned on a vertical line, together with the bent portion **28a** of the storage wiring **28** and **29** of an adjacent pixel.

The bridge electrode **84** electrically connects a pair of storage wires **28** and **29** neighboring with respect to the gate wiring **22** and **24**. Specifically, the bridge electrode **84** electrically connects the horizontal portion **28** of one of the pair of neighboring storage wiring **28** and **29** to the vertical portion **29** of the other storage wiring **28** and **29**. The bridge electrode **84** electrically connects the bent portion **28a** and the projection portion **29a** of the storage wiring **28** and **29** to each other through bridge electrode contact holes **74**, **76**. Thus, since the storage wiring **28** and **29** are electrically connected to each other by means of the bridge electrode **84**, other pixels can be prevented from being affected by signal delay even when any one of the storage wirings **28** and **29** is cut in order to repair pixel defects. This will be described in detail below.

The bridge electrode **84** is made of substantially the same material as that of the pixel electrode **82'** adjacent to the bridge electrode **84**, and the bridge electrode **84** and the pixel electrode **82'** are formed in substantially the same layer. Specifically, when the pixel electrode **82'** is made of transparent, electrically conductive material such as ITO or IZO, the bridge electrode **84** is also formed as an ITO or IZO electrode.

The bridge electrode **84** may be formed in every pixel areas. That is, a pixel area is defined as a red pixel area, a green pixel area or a blue pixel area according to the type of color filter (see reference numeral "130" in FIG. **3**) corresponding thereto, and these pixel areas may be formed with the bridge electrode **84**. The pixel electrode **82'** of the pixel area, in which the bridge electrode **84** is formed, may be narrower than the pixel electrode **82** of the pixel area where the bridge electrode **84** is not formed. That is, in the pixel area where the bridge electrode **84** is formed, the pixel electrode **82'** is spaced apart from the bridge electrode **84** by partially cutting a corner of the pixel electrode **82'**, so as not to be electrically connected to the bridge electrode **84**.

The bridge electrode **84** may be formed in all pixel areas, but it is also possible to form the bridge electrode **84** only in one or two pixel area(s) of the red, green and blue pixel areas. Any one pixel area may be the blue pixel area whose contribution to luminance is minimal. By forming the bridge electrode **84** in every blue pixel areas whose contributions to luminance are minimal, luminance reduction according to the formation of the bridge electrode **84** can be minimized, and

reduction in an aperture ratio can be prevented from being caused by a spacer to be formed in the color filter substrate because the spacer is formed in a portion corresponding to the bridge electrode **84**.

Reference will now be made in detail to a method of repairing bad pixels when pixel defects occur in the LCD device according to the present embodiment, with reference to FIGS. **11** to **14**. FIG. **11** schematically illustrates a method of repairing an open when the open occurs in the data line of the TFT substrate in FIG. **9**, FIG. **12** schematically illustrates a method of repairing a short when the short occurs in the data line of the TFT substrate in FIG. **9**, FIG. **13** schematically illustrates a method of repairing a short when the short occurs in the pixel electrode of the TFT substrate in FIG. **9**, and FIG. **14** schematically illustrates how the bridge electrode functions when an open occurs in the storage wiring of the LCD device in FIG. **9**.

First, the TFT substrate, in which the bridge electrode **84** is formed, is as described in FIGS. **9** and **10**.

As illustrated in FIG. **11**, if an open region  $O_1'$  occurs in the data line **62**, pixel defects occur. In order to repair such pixel defects, laser short regions  $LS_1'$ ,  $LS_2'$  are formed by irradiating a laser beam onto the data line **62** and the vertical portion **29** of the storage wiring **28** and **29** corresponding to both sides of the open region  $O_1'$ , thereby electrically connecting the data line **62** and the storage wiring **28** and **29**. Further, laser cut regions  $LC_1'$ ,  $LC_2'$  are formed by irradiating a laser beam onto the bent portions **28a** of the storage wiring **28** and **29** adjacent to both sides of the opened data line **62**. Since the storage wiring **28** and **29**, connected to each other in a transverse direction, are applied with the same storage voltage, if the laser cut region  $LC_1'$  and  $LC_2'$  exists in the storage wiring **28** and **29** of any one pixel area, the storage voltage of the storage wiring **28** and **29**, connected to each other in the first direction, is not transferred to following pixel areas. However, the storage wiring including the laser cut region  $LC_1'$  and  $LC_2'$  is electrically connected to the storage wiring **28** and **29**, which is disposed in the very next row, by means of the bridge electrode **84**, and thus is applied with a storage voltage signal from the storage wiring **28** and **29** disposed in the next row. For this reason, all pixel areas connected to the storage wiring **28** and **29**, including the laser cut region  $LC_1'$  and  $LC_2'$ , can be prevented from being affected by signal delay.

As illustrated in FIG. **12**, if a short region  $S_1'$  occurs between the data line **62** and the storage wiring **28** and **29**, all storage wiring **28** and **29** connected to the shorted data line **62** are affected by signal interference, which results in pixel defects.

In order to repair such pixel defects, laser cut regions  $LC_3'$  and  $LC_4'$  are formed in two bent portions **28a** positioned on both sides of the shorted data line **62**, respectively, thereby preventing signal interference from occurring in the storage wiring **28** and **29** and the data wiring **62**, **65**, **66**, and **67**. If only the laser cut region  $LC_3'$  and  $LC_4'$  exists in any one pixel area, signal delay does not occur in other pixel areas following that pixel area because the storage wirings **38**, **39** are electrically connected by means of the bridge electrode **84**, which was described with reference to FIG. **1**.

As illustrated in FIG. **13**, if a short region  $S_2'$  occurs between the storage wiring **28** and **29** and the pixel electrode **82'**, laser cut regions  $LC_5'$ ,  $LC_6'$  are formed in the bent portions **28a** adjacent to both sides of the shorted storage wiring **28** and **29**, respectively. If only the laser cut region  $LC_5'$ ,  $LC_6'$  exists in any one pixel area, signal delay does not occur in other pixel areas following that pixel area because the storage

wirings 38, 39 are electrically connected by means of the bridge electrode 84, which was described with reference to FIG. 11.

As illustrated in FIG. 14, if an open region  $O_2'$  occurs in the storage wiring 28 and 29, for example, the horizontal portion 28 thereof, signal delay occurs in the pixel area where the open region  $O_2'$  exists. However, since the storage wiring 28 and 29 of an  $n$ th row is electrically connected to the storage wiring 28 and 29 of an  $(n+1)$ th row by means of the bridge electrode 84, the storage voltage signal, applied to the storage wiring 28 and 29 of the  $(n+1)$ th row, is transferred to the storage wiring 28 and 29 of the  $n$ th row. Thus, whichever pixel area of the  $n$ th row has an open region  $O_2'$ , signal delay, a phenomenon in which a storage signal is not transferred to other pixel areas of the same row, cannot occur.

According to the present invention described above, at least one of the following advantageous effects can be obtained:

First, even if bad pixels are caused by an open of the data line, the bad pixels can be securely and easily repaired using the bent portion and the bridge electrode of the storage wiring.

Second, even if bad pixels are caused by a short between the storage wiring and the data line or the pixel electrode, the bad pixels can be securely and easily repaired using the bent portion and the bridge electrode of the storage wiring.

Last, even if the storage wiring is opened, the bridge electrode electrically connects the opened storage wiring to the storage wiring positioned in a different row, and thus the opened storage wiring does not suffer from signal delay.

Although preferred embodiments of the present invention have been described for illustrative purposes, those skilled in the art will appreciate that various modifications, additions and substitutions are possible, without departing from the essential features and the scope and spirit of the invention as disclosed in the accompanying claims. Therefore, it should be appreciated that the embodiments described above are not limitative, but only illustrative.

What is claimed is:

1. A liquid crystal display device comprising:
  - a first insulating substrate;
  - a gate wiring and a storage wiring arranged substantially parallel to each other in a first direction on the first insulating substrate;
  - a data wiring intersecting but insulated from the gate and storage wirings and arranged substantially in a second direction; and
  - a pixel electrode formed on a pixel area defined by the gate and data wirings,
 wherein the storage wiring comprises a horizontal portion arranged substantially in the first direction and at least a part of which does not overlap the pixel electrode, and a vertical portion branching off substantially in the second direction from the horizontal portion and overlapping the data wiring.
2. The liquid crystal display device of claim 1, wherein the horizontal portion is formed with a bent portion which does not overlap the pixel electrode.
3. The liquid crystal display device of claim 2, wherein the bent portion does not overlap the gate wiring and the data wiring.
4. The liquid crystal display device of claim 3, wherein the bent portion is U-shaped.
5. The liquid crystal display device of claim 1, wherein the vertical portion has a wider width than that of the data wiring.

6. The liquid crystal display device of claim 5, wherein the vertical portion overlaps the pixel electrode along the second direction.

7. The liquid crystal display device of claim 6, wherein the vertical portion overlaps a pair of the pixel electrodes adjoining the vertical portion.

8. The liquid crystal display device of claim 2, further comprising:

an open region formed on the data line;

a laser short region formed by irradiating a laser beam onto the data line and the vertical portion corresponding to both sides of the open region; and

a pair of laser cut regions formed by irradiating a laser beam onto a pair of the horizontal portions which are positioned in the pixel area adjacent to the laser short region and do not overlap the pixel electrode.

9. The liquid crystal display device of claim 2, further comprising:

a short region formed between the data line and the storage wiring; and

a pair of laser cut regions formed by irradiating a laser beam onto a pair of the horizontal portions which are positioned in the pixel area adjacent to the short region and do not overlap the pixel electrode.

10. The liquid crystal display device of claim 2, further comprising:

a short region formed between the storage wiring and the pixel electrode; and

a pair of laser cut regions formed by irradiating a laser beam onto a pair of the horizontal portions which are positioned in the pixel area adjacent to the short region and do not overlap the pixel electrode.

11. The liquid crystal display device of claim 1, further comprising a bridge electrode electrically connecting a pair of the storage wirings, which neighbor the gate wiring, to each other.

12. The liquid crystal display device of claim 11, wherein the bridge electrode electrically connects the horizontal portion of any one of a pair of the storage wirings to the vertical portion of the other storage wiring of the pair of the storage wirings.

13. The liquid crystal display device of claim 11, wherein the bridge electrode and the pixel electrode are made of substantially the same material and are formed in substantially the same layer.

14. The liquid crystal display device of claim 13, wherein the bridge electrode is made of ITO or IZO.

15. The liquid crystal display device of claim 11, wherein the pixel area is defined as a red pixel area, a green pixel area or a blue pixel area according to a color filter type corresponding to the pixel area, and the bridge electrode is formed on the blue pixel area.

16. The liquid crystal display device of claim 1, further comprising:

a second insulating substrate facing the first insulating substrate; and

a black matrix formed on the second insulating substrate and partitioning the pixel area;

wherein the vertical portion has substantially the same width as that of the black matrix.

17. The liquid crystal display device of claim 11, further comprising:

an open region formed on the data line;

a laser short region formed by irradiating a laser beam onto the data line and the vertical portion corresponding to both sides of the open region; and

13

a pair of laser cut regions formed by irradiating a laser beam onto a pair of the horizontal portions which are positioned in the pixel area adjacent to the laser short region and do not overlap the pixel electrode, wherein at least one of the pair of the horizontal portions including the laser short regions is electrically connected to the bridge electrode.

18. The liquid crystal display device of claim 11, further comprising:

a short region formed between the data line and the storage wiring; and

a pair of laser cut regions formed by irradiating a laser beam onto a pair of the horizontal portions which are positioned in the pixel area adjacent to the short region and do not overlap the pixel electrode,

wherein at least one of the pair of the horizontal portions including the laser short regions is electrically connected to the bridge electrode.

19. The liquid crystal display device of claim 11, further comprising:

a short region formed between the storage wiring and the pixel electrode; and

14

a pair of laser cut regions formed by irradiating a laser beam onto a pair of the horizontal portions which are positioned in the pixel area adjacent to the short region and do not overlap the pixel electrode,

wherein at least one of the pair of the horizontal portions including the laser short regions is electrically connected to the bridge electrode.

20. A method of repairing bad pixels of a liquid crystal display device having a thin film transistor substrate with gate wiring and a storage wiring arranged substantially parallel to each other and a pixel electrode wherein at least a part of the storage wiring does not overlap the pixel electrode, comprising:

cutting the storage wiring by irradiating a laser beam onto the part of the storage wiring that does not overlap the pixel electrode.

21. The method of claim 20, further comprising: irradiating a laser beam such that the data line and the storage wiring corresponding to both sides of an open region electrically communicate with each other when the open region occurs in the data line.

\* \* \* \* \*

专利名称(译)	液晶显示装置及其中修复坏像素的方法		
公开(公告)号	<a href="#">US7580108</a>	公开(公告)日	2009-08-25
申请号	US11/934656	申请日	2007-11-02
[标]申请(专利权)人(译)	常JONG WOONG 姜信TACK		
申请(专利权)人(译)	常宗WOONG 姜信TACK		
当前申请(专利权)人(译)	SAMSUNG ELECTRONICS CO. , LTD.		
[标]发明人	CHANG JONG WOONG KANG SHIN TACK		
发明人	CHANG, JONG-WOONG KANG, SHIN-TACK		
IPC分类号	G02F1/13 G02F1/1343 G02F1/1368		
CPC分类号	G02F1/136259 G02F1/136213 G02F2001/136263 G02F1/133345 G02F1/136286 G02F1/1368 G02F1/1309 G02F1/13624 H01L27/1244 H01L29/41733 H01L29/78603		
代理机构(译)	海恩斯和布恩, LLP		
审查员(译)	内尔姆斯, DAVID		
优先权	1020060108410 2006-11-03 KR		
其他公开文献	US20080117349A1		
外部链接	<a href="#">Espacenet</a> <a href="#">USPTO</a>		

摘要(译)

一种液晶显示装置及其坏像素的修复方法，其中可以有效且容易地修复坏像素，包括第一绝缘基板，栅极布线和在第一方向上基本上彼此平行布置的存储布线。第一绝缘基板，以绝缘方式与栅极和存储布线交叉并且基本上沿第二方向布置的数据布线，以及形成在由栅极和数据布线限定的像素区域上的像素电极。存储布线包括：水平部分，基本上沿第一方向布置，并且其至少一部分不与像素电极重叠；以及垂直部分，从水平部分基本沿第二方向分支并与数据布线重叠。

