



(19) **United States**

(12) **Patent Application Publication**
Kim

(10) **Pub. No.: US 2008/0024712 A1**

(43) **Pub. Date: Jan. 31, 2008**

(54) **DISTORTION RESISTANT TOUCH-SENSITIVE DISPLAY PANEL**

Publication Classification

(76) Inventor: **Dong-Gyu Kim, Gyeonggi-do (KR)**

(51) **Int. Cl.**
G02F 1/1343 (2006.01)
H01L 27/105 (2006.01)
(52) **U.S. Cl.** **349/144; 257/203**

Correspondence Address:
MACPHERSON KWOK CHEN & HEID LLP
2033 GATEWAY PLACE, SUITE 400
SAN JOSE, CA 95110

(57) **ABSTRACT**

An array substrate includes a plurality of gate lines, a plurality of data lines, a plurality of thin-film transistors, a plurality of pixel electrodes, a plurality of common voltage lines and a plurality of common electrodes. The gate lines extend in a first direction. The data lines extend in a second direction substantially perpendicular to the first direction. The thin-film transistor is electrically connected to the gate line and the data line. The pixel electrode is formed in each of pixels defined by the gate lines and the data lines. The common electrode is electrically connected to the common voltage line. The horizontal alignment of the liquid crystal molecules is not changed by externally applied vertical touch pressure so that display quality is improved.

(21) Appl. No.: **11/744,696**

(22) Filed: **May 4, 2007**

(30) **Foreign Application Priority Data**

Jul. 25, 2006 (KR) 2006-69444

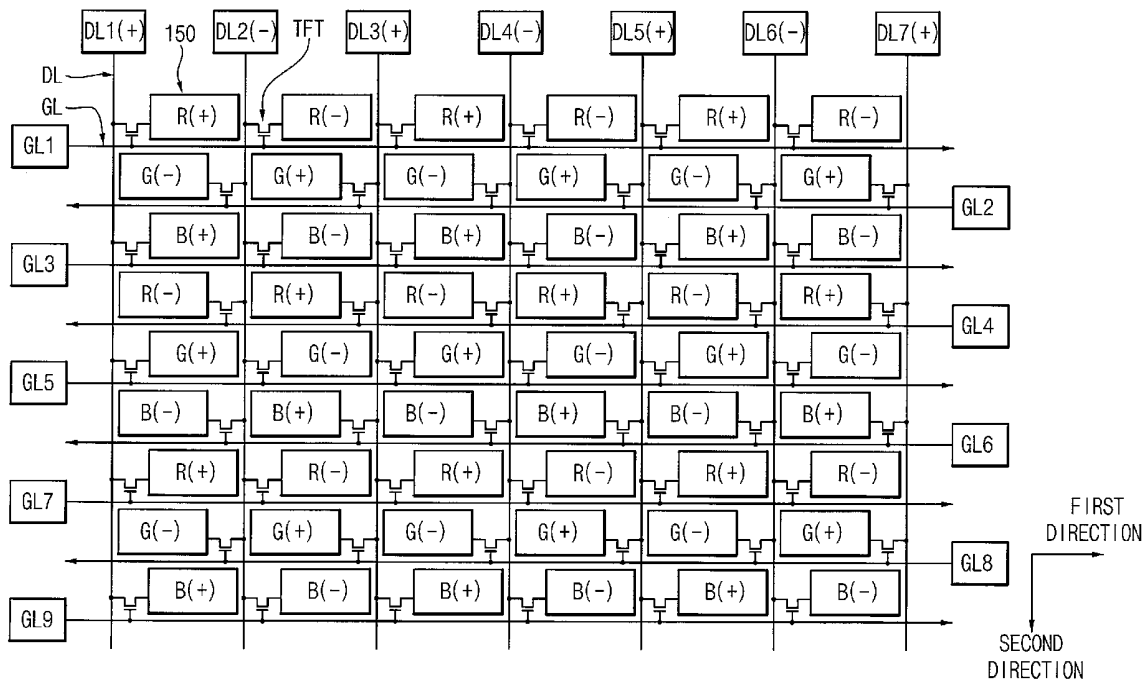

FIG. 1

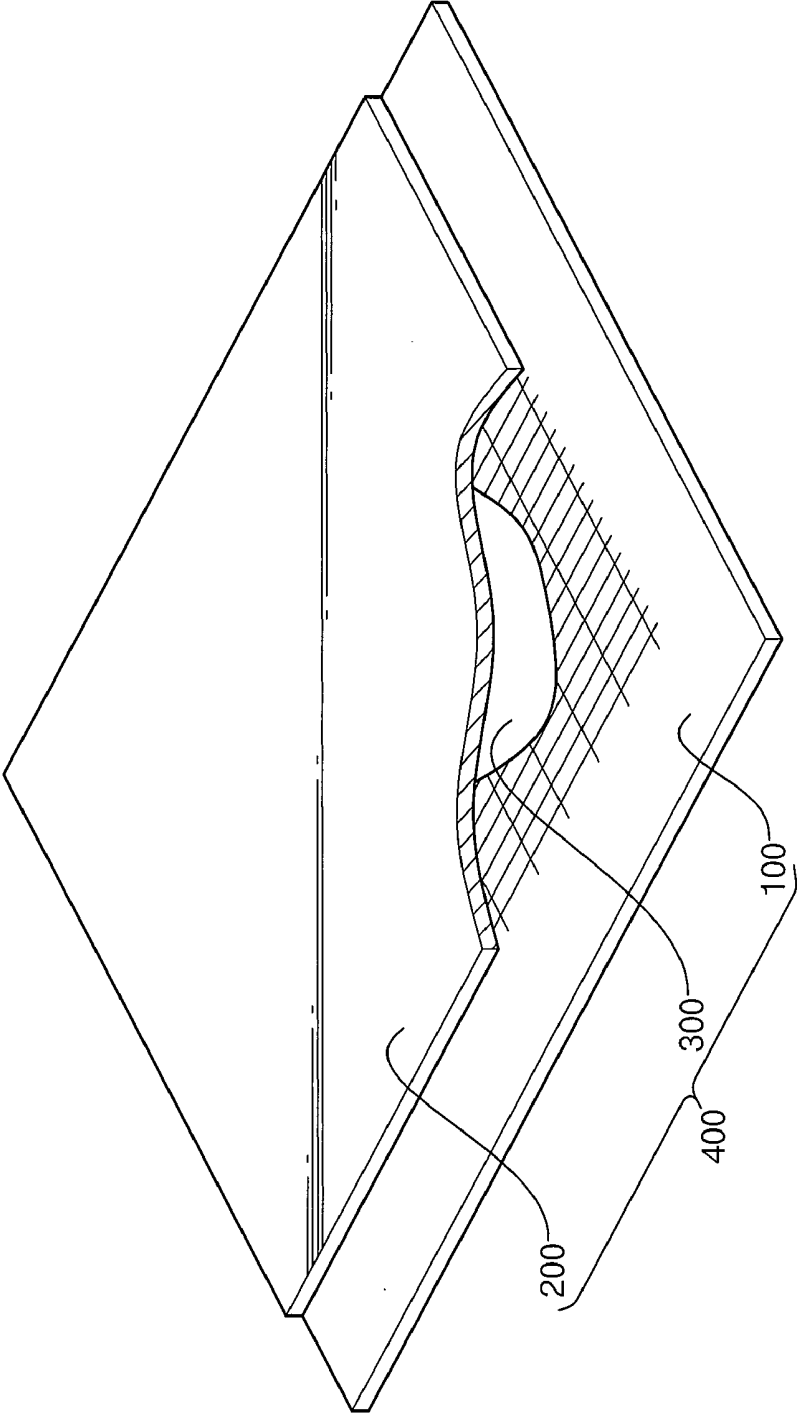

FIG. 2

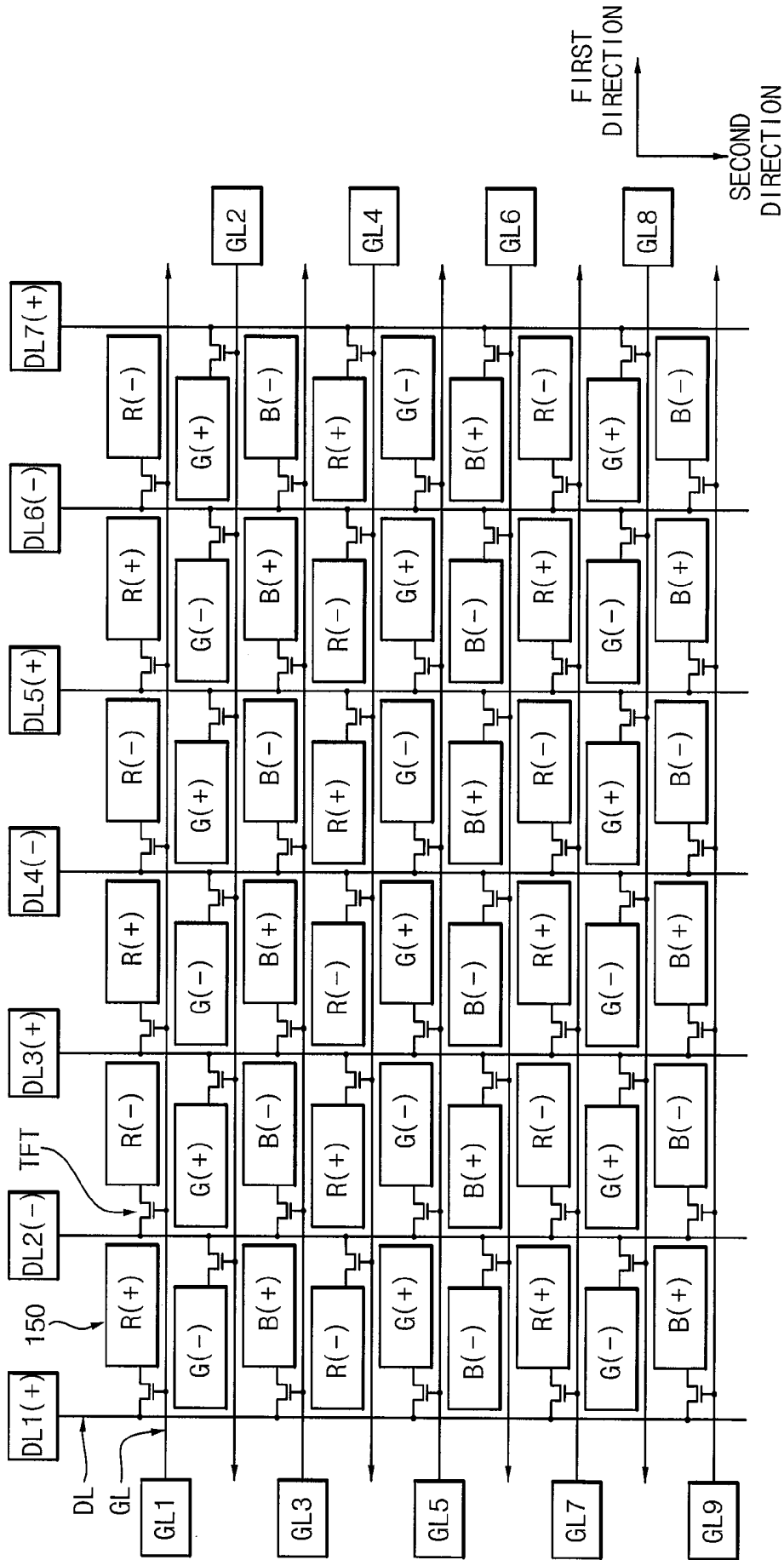

FIG. 3

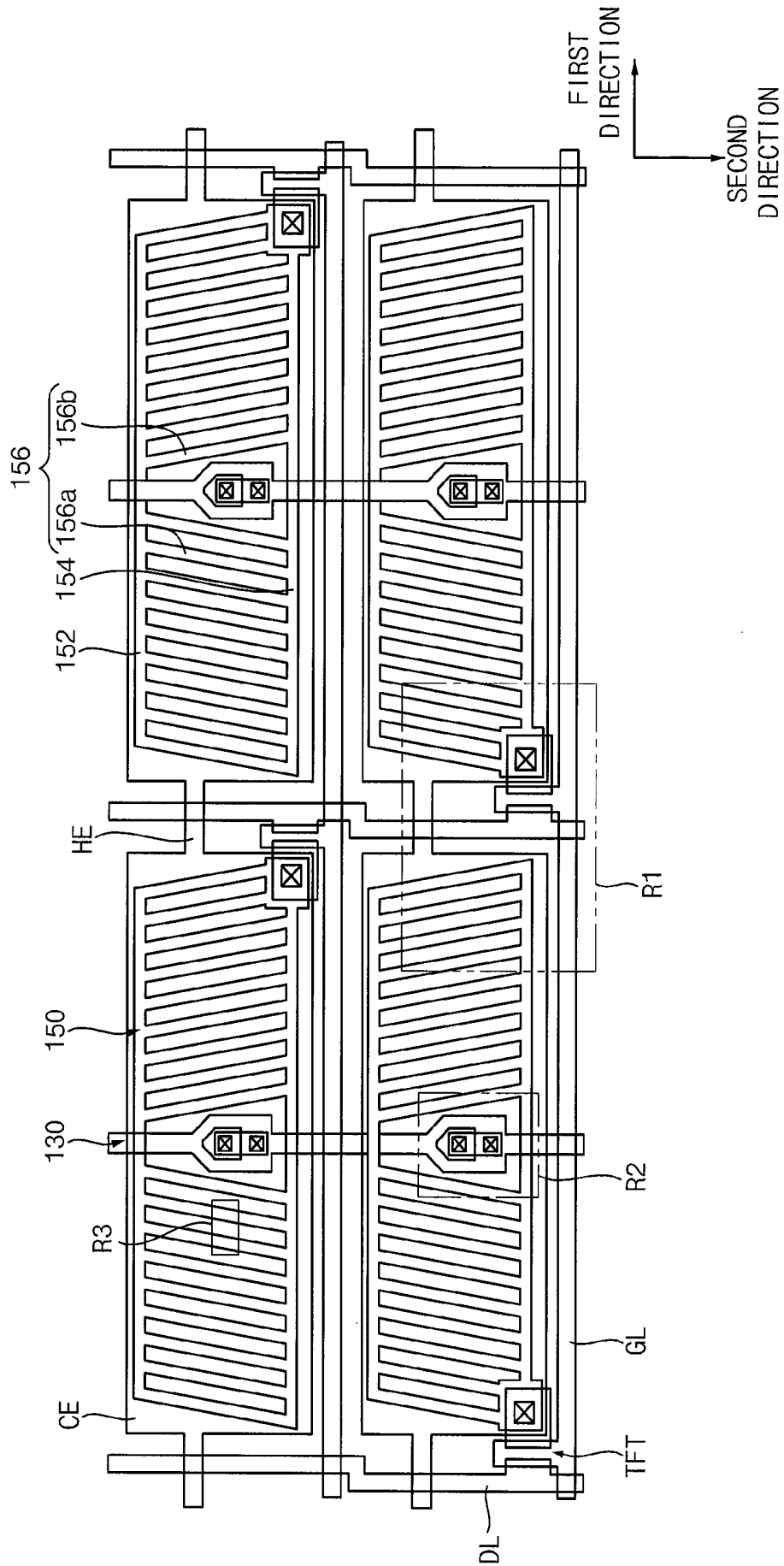

FIG. 4

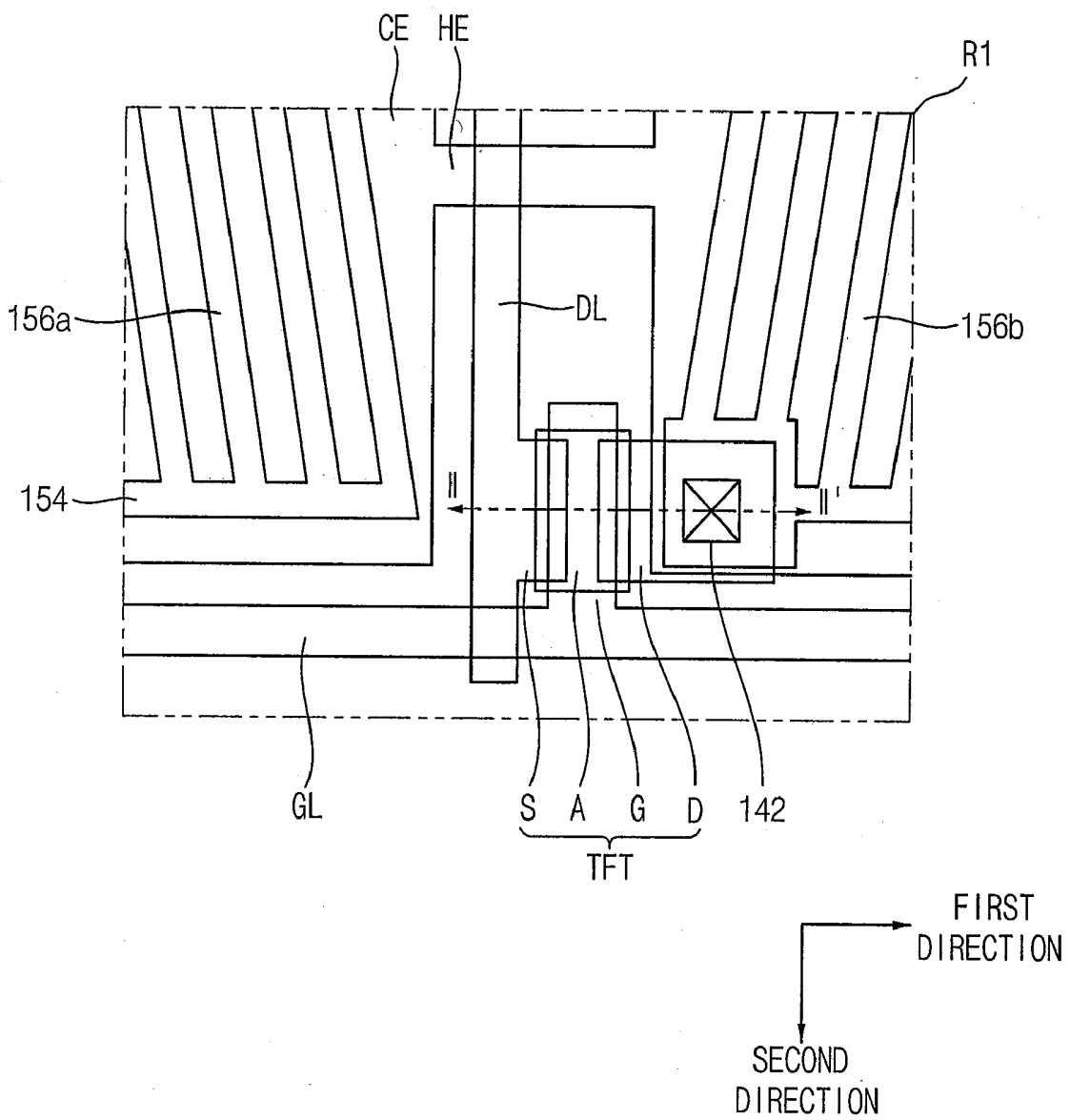

FIG. 6

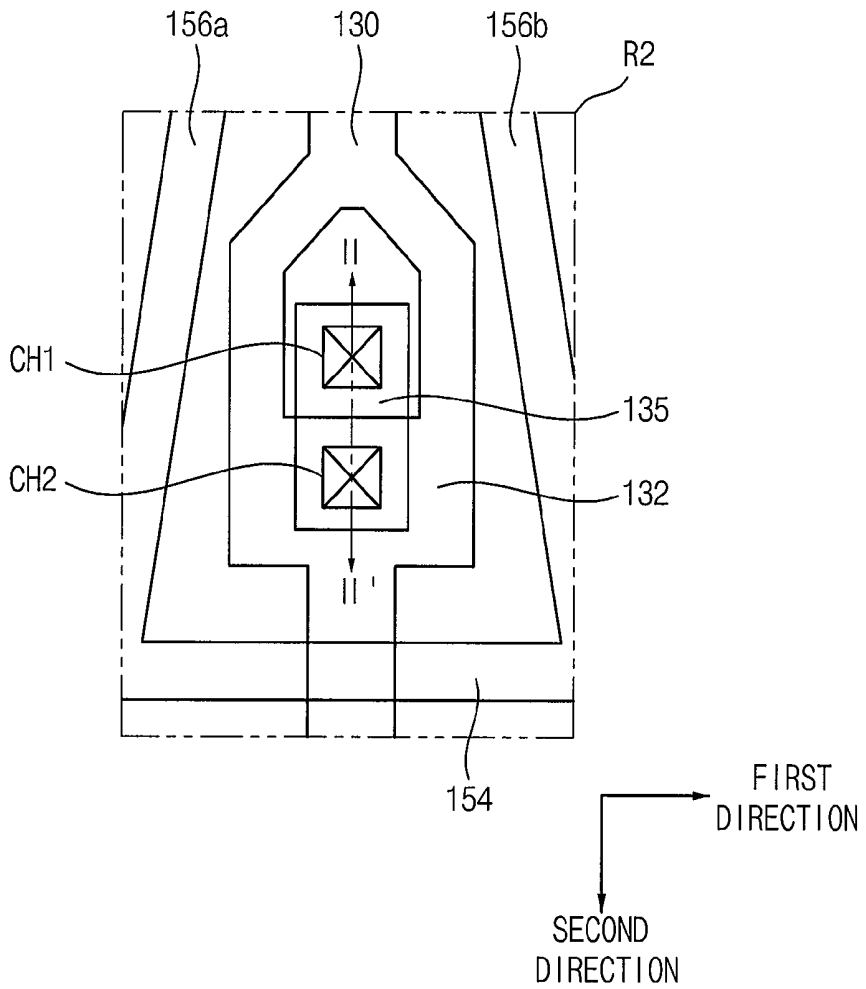

FIG. 7

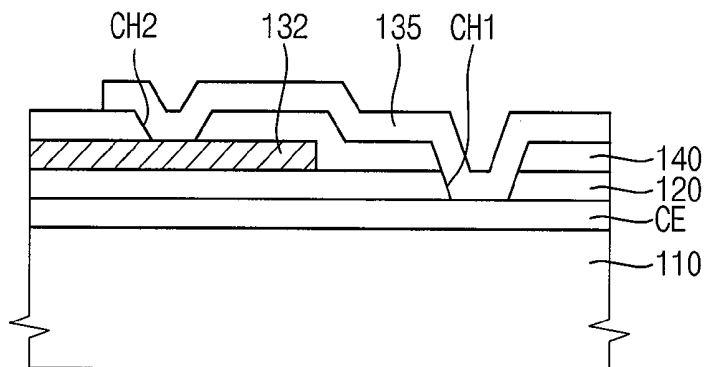

FIG. 8

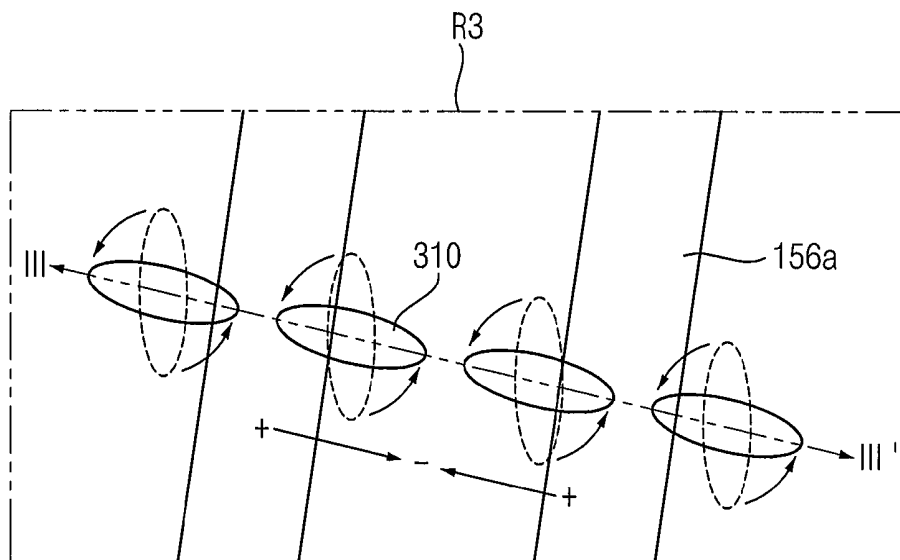

FIG. 9

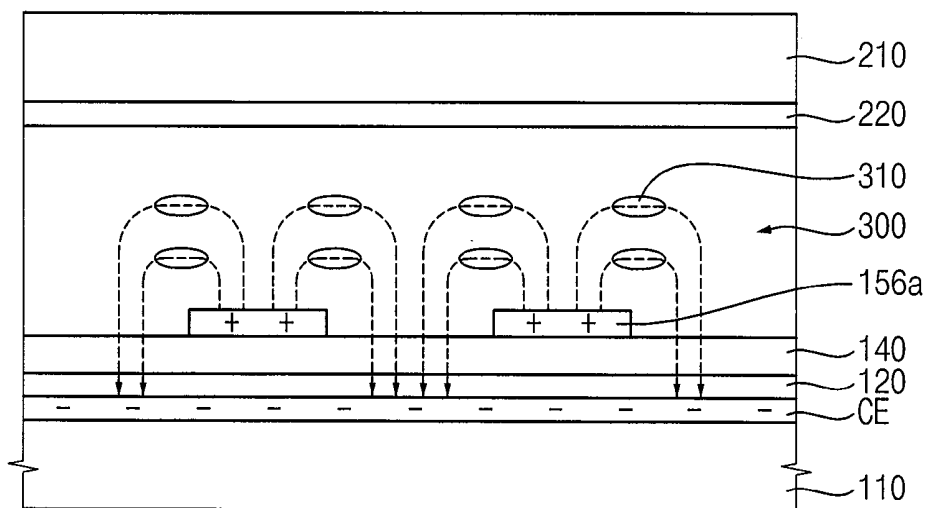

FIG. 10

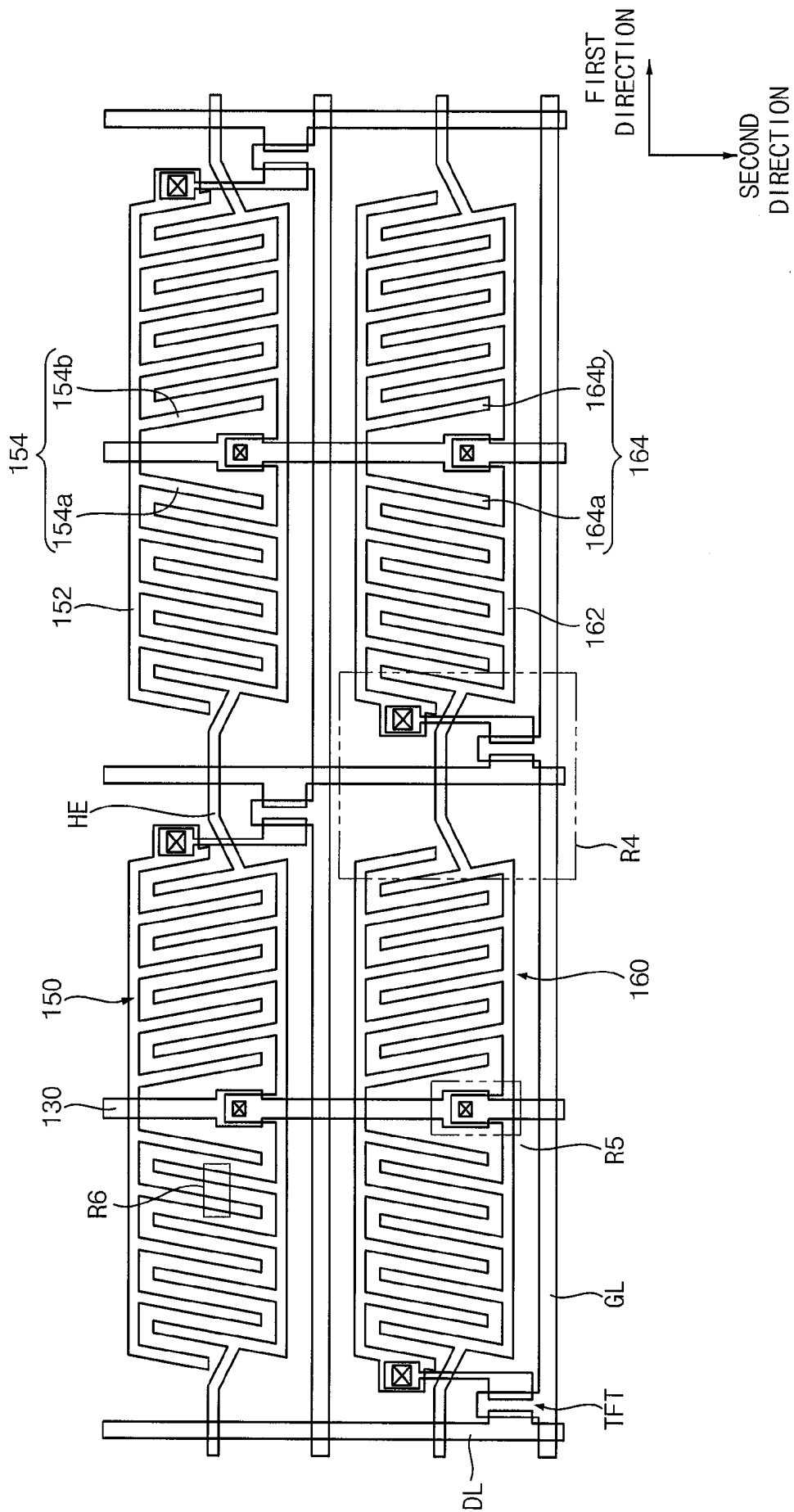

FIG. 12

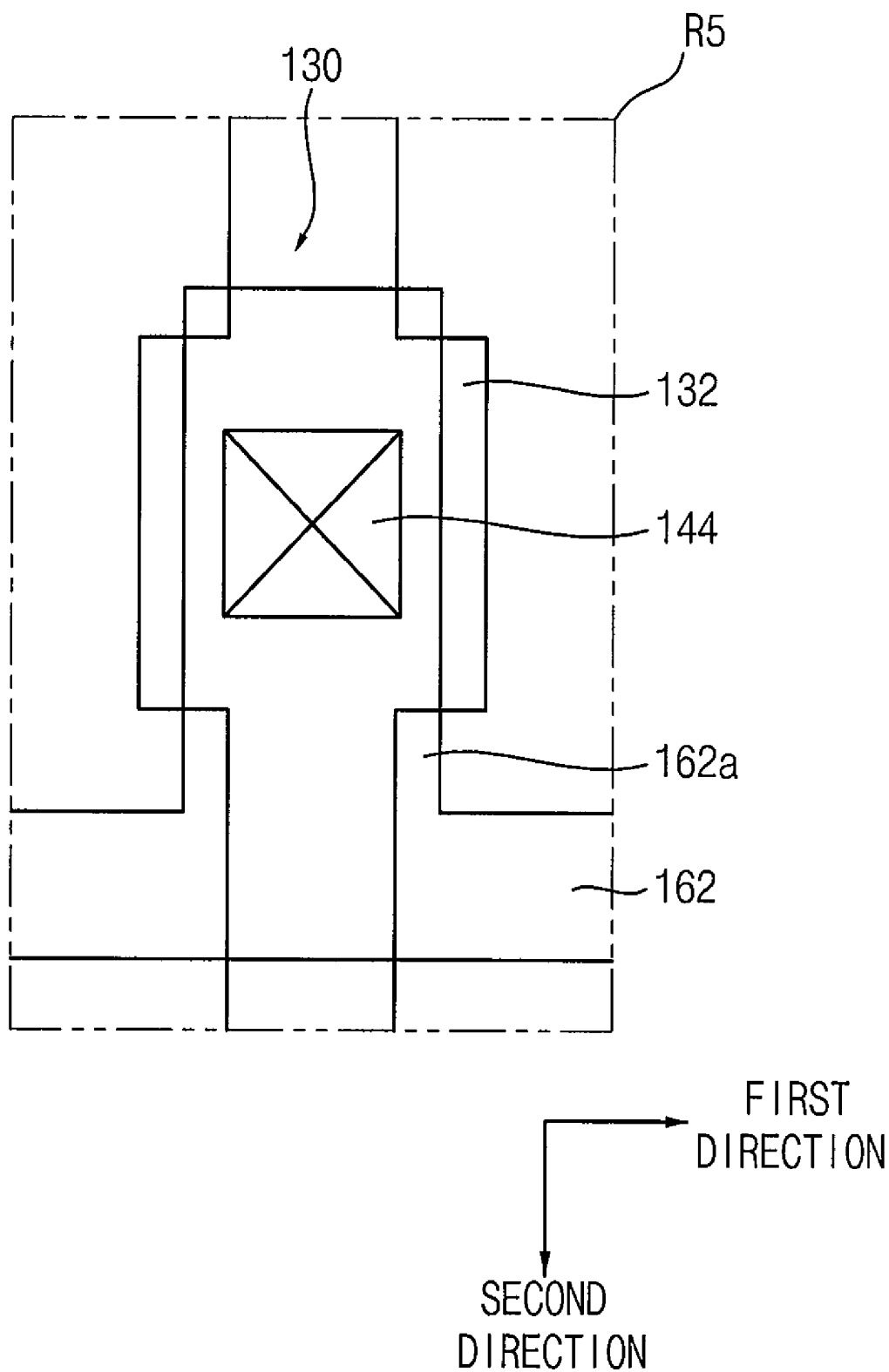

FIG. 13

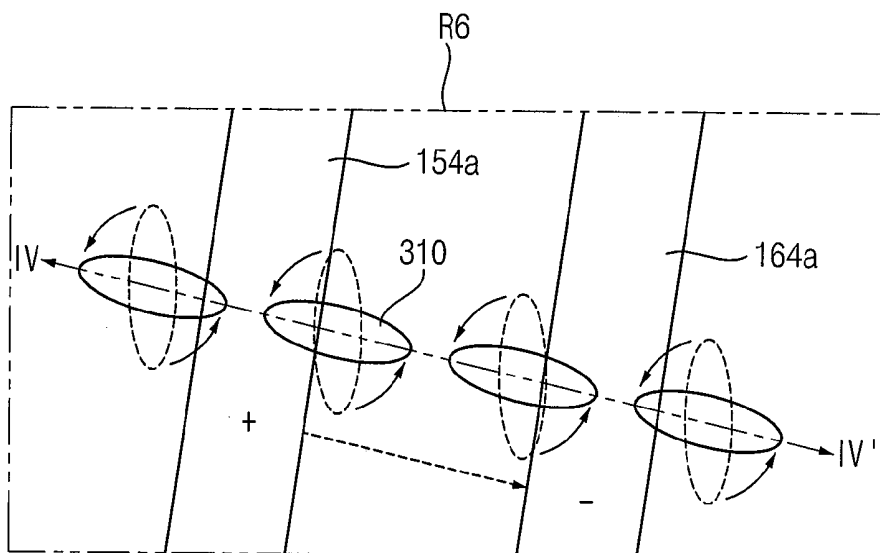
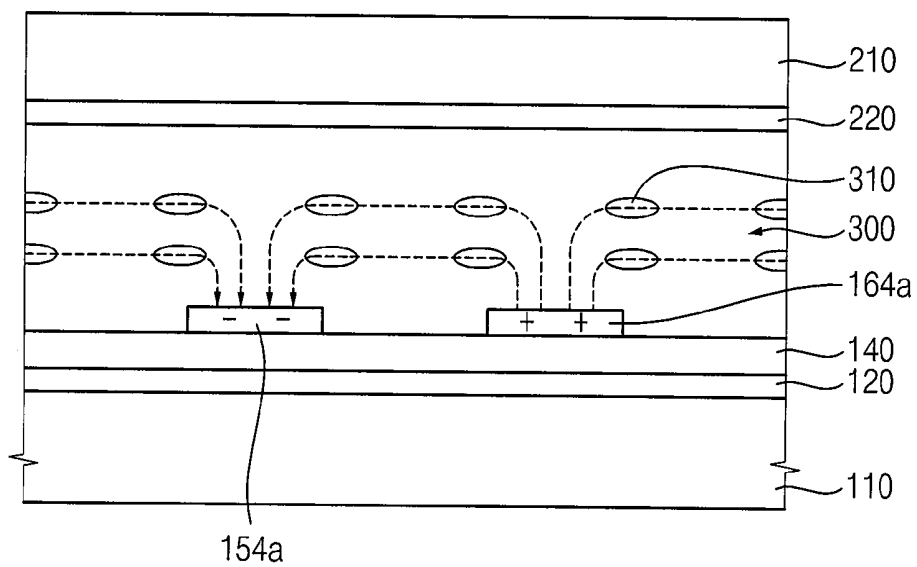

FIG. 14



DISTORTION RESISTANT TOUCH-SENSITIVE DISPLAY PANEL

CROSS-REFERENCE TO RELATED APPLICATION

[0001] This application relies for priority upon Korean Patent Application No. 2006-69444 filed in the Korean Intellectual Property Office on Jul. 25, 2006, the contents of which are incorporated herein by reference in its entirety.

BACKGROUND OF THE INVENTION

[0002] 1. Field of the Invention

[0003] The present invention relates to a display panel having a touch-sensitive display and, more particularly, to a display panel that is resistant to image distortion when touched.

[0004] 2. Description of the Related Art

[0005] A flat panel display apparatus such as a liquid crystal display (LCD) having a touch-sensitive screen receives an input signal when touched by an external pen. Generally, an LCD apparatus displays an image using the optical and electrical properties of liquid crystal and displays an image using incident light and/or light from a backlight assembly. An LCD panel includes an array substrate, a color filter substrate and a liquid crystal layer interposed between the array substrate and the color filter substrate. The array substrate has a thin-film transistor. When pressure is applied to the LCD apparatus by an external pen, the alignment of the liquid crystal molecules in the liquid crystal layer of the LCD apparatus is changed and the image displayed by the LCD apparatus may be locally distorted.

SUMMARY OF THE INVENTION

[0006] According to one aspect of the present invention, an array substrate includes a plurality of gate lines, a plurality of data lines, a plurality of thin-film transistors, a plurality of pixel electrodes, a plurality of common voltage lines and a plurality of common electrodes. The gate lines extend in a first direction and the data lines extend in a second direction substantially perpendicular to the first direction. A thin-film transistor is electrically connected to the gate line and the data line. The pixel electrode is formed in each pixel defined by the intersecting directions of the gate lines and the data lines and is electrically connected to the thin-film transistors. A common voltage line extends in the second direction substantially parallel to the data line. The common electrode is formed in each of the pixels, is electrically insulated from the pixel electrode, and is electrically connected to the common voltage line. For example, the pixel electrode and the common electrode may include a transparent conductive material.

[0007] The pixel electrode may include a first main pixel electrode, a second main pixel electrode and a plurality of sub pixel electrodes. The first main pixel electrode extends in the first direction, and is adjacent to one of the gate lines. The second main pixel electrode also extends in the first direction, is spaced apart from the first main pixel electrode by a predetermined distance, and is located adjacent to one of the gate lines. The sub pixel electrodes are disposed between the first and second main pixel electrodes to connect the first and second main pixel electrodes, and are arranged in the first direction. The common electrode may

be disposed under the pixel electrode, and an insulation layer may be formed between the common electrode and the pixel electrode.

[0008] Alternatively, the pixel electrode may include a main pixel electrode and a plurality of sub pixel electrodes. The main pixel electrode extends in the first direction, and is adjacent to one of the gate lines. The sub pixel electrodes protrude from the main pixel electrode toward a consecutive one of the gate lines, and are arranged in the first direction. The common electrode may include a main common electrode and a plurality of sub common electrodes. The main common electrode extends in the first direction, and is adjacent to a consecutive one of the gate lines. The sub common electrodes protrude from the main common electrode toward the main pixel electrode, and are arranged in the first direction.

[0009] In another aspect of the present invention, a display panel includes an array substrate, an opposite substrate facing the array substrate and a liquid crystal layer being interposed between the array substrate and the opposite substrate and having liquid crystal molecules.

[0010] The array substrate includes a plurality of gate lines, a plurality of data lines, a plurality of thin-film transistors, a plurality of pixel electrodes, a plurality of common voltage lines and a plurality of common electrodes. The gate lines extend in a first direction. The data lines extend in a second direction substantially perpendicular to the first direction. The thin-film transistor is electrically connected to the gate line and the data line. The pixel electrode is formed in each pixel defined by the gate lines and the data lines, and is electrically connected to each of the thin-film transistors. The common voltage line extends in the second direction being substantially parallel with the data line. The common electrode is formed in each of the pixels, and is electrically insulated from the pixel electrode, and is electrically connected to the common voltage line.

[0011] For example, the liquid crystal molecules of the liquid crystal layer may be aligned substantially parallel with a surface of the array substrate, and may be rotated by an electric field formed by the pixel electrode and the common electrode by a predetermined angle with being substantially parallel with the surface of the array substrate.

[0012] According to the above, the liquid crystal molecules are substantially parallel with the surface of the array substrate. Thus, an alignment of the liquid crystal molecules may not be changed by an external pressure for a touch screen function. Therefore, a display quality may be improved.

BRIEF DESCRIPTION OF THE DRAWINGS

[0013] The above and other advantages of the present invention will become readily apparent by reference to the following detailed description when considered in conjunction with the accompanying drawings, in which:

[0014] FIG. 1 is a perspective view illustrating a display panel according to an exemplary embodiment of the present invention;

[0015] FIG. 2 is a schematic plan view illustrating an array substrate of the display panel illustrated in FIG. 1;

[0016] FIG. 3 is an enlarged plan view illustrating a portion of FIG. 2;

[0017] FIG. 4 is an enlarged plan view illustrating a region 'R1' of FIG. 3;

[0018] FIG. 5 is a cross-sectional view taken along a line I-I' of FIG. 4;

[0019] FIG. 6 is an enlarged plan view illustrating a region 'R2' of FIG. 3;

[0020] FIG. 7 is a cross-sectional view taken along a line II-II' of FIG. 6;

[0021] FIG. 8 is an enlarged plan view illustrating a region 'R3' of FIG. 3;

[0022] FIG. 9 is a cross-sectional view taken along a line III-III' of FIG. 8;

[0023] FIG. 10 is a plan view illustrating a portion of an array substrate of a display panel according to another exemplary embodiment of the present invention;

[0024] FIG. 11 is an enlarged plan view illustrating a region 'R4' of FIG. 10;

[0025] FIG. 12 is an enlarged plan view illustrating a region 'R5' of FIG. 10;

[0026] FIG. 13 is an enlarged plan view illustrating a region 'R6' of FIG. 10; and

[0027] FIG. 14 is a cross-sectional view taken along a line IV-IV' of FIG. 13.

DESCRIPTION OF THE EMBODIMENTS

[0028] In the drawings, the size and relative sizes of layers and regions may be exaggerated for clarity. It will be understood that when an element or layer is referred to as being "on," "connected to" or "coupled to" another element or layer, it can be directly on, connected or coupled to the other element or layer or intervening elements or layers may be present. In contrast, when an element is referred to as being "directly on," "directly connected to" or "directly coupled to" another element or layer, there are no intervening elements or layers present.

[0029] FIG. 1 is a perspective view illustrating a display panel according to an exemplary embodiment of the present invention.

[0030] Referring to FIG. 1, a display panel 400 includes an array substrate 100, an opposite substrate 200 and a liquid crystal layer 300 to display an image using light.

[0031] Array substrate 100 includes a plurality of pixel electrodes arranged in a matrix configuration, a plurality of thin-film transistors to apply a driving voltage to the pixel electrodes and a plurality of signal lines to drive the thin-film transistors. Array substrate 100 further includes a common electrode to which a common voltage is applied.

[0032] The opposite substrate 200 faces array substrate 100. The opposite substrate 200 may include a plurality of color filters facing the pixel electrodes. Examples of color filters may include a red color filter, a green color filter, a blue color filter, etc.

[0033] The liquid crystal layer 300 is interposed between array substrate 100 and the opposite substrate 200. The liquid crystal is reoriented by the varying electric field applied between the pixel electrode and the common electrode. The reoriented crystals control the transmittance of light passing through the color filters to display the image.

[0034] FIG. 2 is a schematic plan view illustrating an array substrate of the display panel illustrated in FIG. 1.

[0035] Referring to FIG. 2, array substrate 100 includes a gate line GL, a data line DL, a thin-film transistor TFT and a pixel electrode 150.

[0036] A plurality of gate lines GL is arranged in a first direction. A plurality of data lines DL is arranged in a second direction substantially perpendicular to the first direction.

For example, array substrate 100 may include nine gate lines GL1, GL2, . . . , GL9 and seven data lines DL1, DL2, . . . , DL7 as illustrated in FIG. 2. Each of gate lines GL1, GL2, . . . , GL9 is electrically connected to a gate driver (not shown), and is provided with a gate signal. Each of data lines DL1, DL2, . . . , DL7 is electrically connected to a data driver (not shown), and is provided with a data signal.

[0037] The gate driver includes a first gate driver electrically connected to a first end of each odd-numbered gate lines GL1, GL3, . . . , GL9 and a second gate driver electrically connected to a second end of each even-numbered gate lines GL2, GL4, . . . , GL8, which is opposite to the first end. Alternatively, the gate driver may be electrically connected to an end of each of gate lines GL1, GL2, . . . , GL9.

[0038] Gate lines GL1, GL2, . . . , GL9 cross data lines DL1, DL2, . . . , DL7 in a substantially perpendicular direction so that a plurality of pixels is defined on array substrate 100. A pixel electrode 150 is formed in each of the pixels. Thus, a plurality of pixel electrodes 150 is arranged in a matrix configuration on array substrate 100.

[0039] Each of the pixels may have a rectangular shape. Thus, pixel electrode 150 formed in each of the pixels may have a shape substantially the same as the shape of each of the pixels.

[0040] A thin-film transistor TFT is formed in each of the pixels to correspond to each of the pixel electrodes 150. Thin-film transistor TFT is electrically connected to gate line GL, data line DL and pixel electrode 150. Thin-film transistor TFT is switched by the gate signal on gate line GL to apply the data signal on data line DL to pixel electrode 150. The thin-film transistors TFT electrically connected to one of the data lines DL may be alternatively located adjacent to a first side of data line DL and a second side of data line DL, which is opposite to the first side, when viewed in plan view. Particularly, each of gate lines GL1, GL2, . . . , GL9 is electrically connected to the adjacent thin-film transistors TFT arranged in a row.

[0041] The thin-film transistors TFT connected to the first data line DL1 are connected to the odd-numbered gate lines GL1, GL3, . . . , GL9. The thin-film transistors TFT connected to the seventh data line DL7 are connected to the even-numbered gate lines GL2, GL4, . . . , and GL8. The thin-film transistors TFT adjacent to a first side of the remaining data lines DL2, DL3, DL4, DL5 and DL6, are connected to the odd-numbered gate lines GL1, GL3, GL9. The thin-film transistors TFT adjacent to the second side of the remaining data lines DL2, DL3, DL4, DL5 and DL6, are connected to the even-numbered gate lines GL2, GL4, GL8.

[0042] For example, each of the data lines DL1, DL2, DL7 may be provided with a data signal for a vertical inversion. For example, when the first data line DL1 is provided with a data signal having a positive voltage in one frame, an adjacent data line, the second data line DL2 is provided with a data signal having a negative voltage in the frame. In contrast, the first data line DL1 is provided with a data signal having a negative voltage in a next frame, and the second data line DL2 is provided with a data signal having a positive voltage in the next frame. Thus, the pixel electrodes 150 may be driven in a dot inversion method.

[0043] FIG. 3 is an enlarged plan view illustrating a portion of FIG. 2. FIG. 4 is an enlarged plan view illustrating a region 'R1' of FIG. 3. FIG. 5 is a cross-sectional view taken along a line of I-I' of FIG. 4. FIG. 6 is an enlarged plan

view illustrating a region 'R2' of FIG. 3. FIG. 7 is a cross-sectional view taken along a line II-II' of FIG. 6. FIG. 8 is an enlarged plan view illustrating a region 'R3' of FIG. 3. FIG. 9 is a cross-sectional view taken along a line II-II' of FIG. 8.

[0044] Referring to FIGS. 1, 3, 4, 5, 6, 7, 8 and 9, a display panel 400 includes an array substrate 100, an opposite substrate 200 and a liquid crystal layer 300.

[0045] Array substrate 100 includes a first transparent substrate 110, a gate line GL, a common electrode CE, a horizontal connection electrode HE, a first insulation layer 120, a data line DL, a thin-film transistor TFT, a common voltage line 130, a second insulation layer 140, a pixel electrode 150 and a vertical connection electrode 135.

[0046] First transparent substrate 110 has a plate-shape, and includes a transparent material such as glass, quartz, transparent synthetic resin, etc.

[0047] Referring to FIG. 3, gate line GL extends a first direction on first transparent substrate 110, and a plurality of data lines DL is arranged in a second direction substantially perpendicular to the first direction.

[0048] A first insulation layer 120 is formed on first transparent substrate 110 to cover gate line GL. Examples of a material that may be used for the first insulation layer 120 may include silicon nitride (SiNx), silicon oxide (SiOx), etc.

[0049] Referring to FIG. 3, data line DL is formed on the first insulation layer 120, and extends in the second direction to cross gate line GL. A plurality of the data lines DL is arranged in the second direction. Data line DL may have a linear shape in the second direction. Alternatively, data line DL may have a bending portion, for example, a zigzag-shape. The data lines DL cross the gate lines GL so that a plurality of pixels is defined.

[0050] Common electrode CE is formed in each of the pixels on first transparent substrate 110, and is covered by first insulation layer 120. Common electrode CE may have a rectangular shape, and may include a transparent conductive material.

[0051] The horizontal connection electrode HE is disposed between adjacent common electrodes CE to electrically connect the common electrodes CE to each other. The horizontal connection electrode HE is formed from a layer substantially the same as the common electrode CE. Particularly, the horizontal connection electrode HE is formed on first transparent substrate 110, and is covered by the first insulation layer 120. The horizontal connection electrode HE may include a transparent conductive material.

[0052] Referring to FIGS. 3, 4 and 5, thin-film transistor TFT is formed in each of the pixels, and is electrically connected to gate line GL, data line DL and pixel electrode 150.

[0053] Particularly, thin-film transistor TFT includes a gate electrode G, an active layer A, a source electrode S, a drain electrode D and an ohmic contact layer O.

[0054] Gate electrode G protrudes from gate line GL by a predetermined length. For example, gate electrode G may protrude from gate line GL in a direction substantially parallel with data line DL.

[0055] The active layer A is formed on the first insulation layer 120, and is overlapped with gate electrode G. For example, the active layer A may have a rectangular shape, and may include amorphous silicon (a-Si).

[0056] Source electrode S protrudes from data line DL by a predetermined length, and is overlapped with a portion of

the active layer A. For example, source electrode S may protrude from data line DL in a direction substantially parallel with gate line GL.

[0057] Drain electrode D is spaced apart from source electrode S by a predetermined distance, and is formed from a layer substantially the same as source electrode S. Drain electrode D is overlapped with a portion of the active layer A. Furthermore, drain electrode D is overlapped with a portion of pixel electrode 150 to be electrically connected to pixel electrode 150.

[0058] Ohmic contact layer O is formed between source electrode S and the active layer A and between drain electrode D and the active layer A. Ohmic contact layer O may include amorphous silicon (a-Si), into which n+ impurities are implanted at a high concentration.

[0059] The second insulation layer 140 is formed on the first insulation layer 120 to cover thin-film transistor TFT and data line DL. Examples of a material that may be used for the second insulation layer 140 may include silicon nitride (SiNx), silicon oxide (SiOx), etc.

[0060] Referring to FIGS. 3, 6 and 7, the common voltage line 130 extends in the second direction to cross the pixel. A plurality of the common voltage lines 130 is arranged in the first direction. Particularly, the common voltage line 130 may cross a central portion of the pixel. The common voltage line 130 is formed from a layer substantially the same as data line DL. Particularly, the common voltage line 130 is formed on the first insulation layer 120 and is covered by the second insulation layer 140. The common voltage line 130 has a common voltage connection portion 132 to electrically connect the common voltage line 130 and the common electrode CE. For example, an opening may be formed through a central portion of the common voltage connection portion 132, and the common voltage connection portion 132 may be substantially symmetric with respect to a central line of the pixel, which is substantially parallel with the second direction.

[0061] Vertical connection electrode 135 is formed on the second insulation layer 140 to electrically connect the common voltage line 130 and the common electrode CE.

[0062] Particularly, a portion of each of the first and second insulation layers 120 and 140 is removed to form a first common contact hole CH1. The first common contact hole CH1 may be formed in the opening of the common voltage connection portion 132. Furthermore, a portion of the second insulation layer 140, which is overlapped with the common voltage connection portion 132, is removed to form a second common contact hole CH2.

[0063] Vertical connection electrode 135 is formed on the second insulation layer 140, and is electrically connected to the common electrode CE through the first common contact hole CH1, and is electrically connected to the common voltage connection portion 132 through the second common contact hole CH2. Thus, vertical connection electrode 135 electrically connects the common voltage line 130 to the common electrode CE.

[0064] Referring to FIGS. 3 and 4, pixel electrode 150 is formed on the second insulation layer 140 in each pixel. Pixel electrode 150 is electrically connected to drain electrode D of thin-film transistor TFT through a pixel contact hole 142 formed through the second insulation layer 140. Pixel electrode 150 includes a transparent conductive material. Common electrode CE is disposed under pixel electrode

150 may be larger than pixel electrode **150** to cover pixel electrode **150** when viewed from a plan view.

[0065] Pixel electrode **150** includes a first main pixel electrode **152**, a second main pixel electrode **154** and a sub pixel electrode **156**. Pixel electrode **150** may be substantially symmetric with respect to the central line of the pixel.

[0066] The first main pixel electrode **152** is adjacent to one of the gate lines GL, and extends in the first direction.

[0067] The second main pixel electrode **154** is spaced apart from the first main pixel electrode **152** by a predetermined distance, and extends in the first direction. Particularly, the second main pixel electrode **154** is adjacent to a consecutive one of the gate lines GL.

[0068] The sub pixel electrode **156** is disposed between the first and second main pixel electrodes **152** and **154** and connected to the first and second main pixel electrodes **152** and **154**. A plurality of the sub pixel electrodes **156** may be arranged in the first direction.

[0069] The sub pixel electrode **156** may be substantially symmetric with respect to the central line of the pixel. For example, the sub pixel electrode **156** may include a first sub pixel electrode **156a** and a second sub pixel electrode **156b**, which are substantially symmetric with respect to the central line of the pixel.

[0070] The first sub pixel electrode **156a** is adjacent to a first side of the central line of the pixel, and may be tilted with the second direction by a predetermined angle. For example, the first sub pixel electrode **156a** may be tilted with the second direction by about 0.5 to about 5 degrees.

[0071] The second sub pixel electrode **156b** is adjacent to a second side of the central line of the pixel, which is opposite to the first side, and may be tilted so that the first and second sub pixel electrodes **156a** and **156b** are substantially symmetric with respect to the central line of the pixel. The second sub pixel electrode **156b** is tilted by about 0.5 to about 5 degrees in a direction opposite to the first sub pixel electrode **156a**.

[0072] Array substrate **100** may further include a first alignment layer (not shown) to align liquid crystal molecules of the liquid crystal layer **300** in a predetermined direction. The first alignment layer is formed on the second insulation layer **140** to cover pixel electrode **150** and vertical connection electrode **135**.

[0073] Hereinafter, the opposite substrate **200** and the liquid crystal layer **300** are more fully described with reference to FIGS. **8** and **9**.

[0074] The opposite substrate **200** faces array substrate **100**. The opposite substrate **200** includes a second transparent substrate **210** and a light-blocking layer (not shown). The opposite substrate **200** may further include a color filter **220**.

[0075] The second transparent substrate **210** may include a transparent material, and may have a plate-shape.

[0076] The light-blocking layer is formed on the second transparent substrate **210** to face array substrate **100**. The light-blocking layer may be large enough to cover gate line GL, data line DL and thin-film transistor TFT.

[0077] The color filter **220** is formed on the second transparent substrate **210**, and is overlapped with pixel electrode **150**. Alternatively, the color filter **220** may be formed on array substrate **100**.

[0078] The opposite substrate **100** may further include a second alignment layer (not shown) to align the liquid

crystal molecules **310** of the liquid crystal layer **300** in a predetermined direction. The second alignment layer covers the color filter **220**.

[0079] The liquid crystal layer **300** is interposed between array substrate **100** and the opposite substrate **200**. The liquid crystal molecules **310** of the liquid crystal layer **300** are aligned by the first and second alignment layers in a predetermined direction. Particularly, the liquid crystal molecules **310** may be aligned substantially parallel with a surface of array substrate **100** in the second direction.

[0080] When a first voltage is applied to the common electrode CE, and a second voltage having a voltage level different from the first voltage is applied to pixel electrode **150**, an electric field is formed between the common electrode CE and pixel electrode **150**. The electric field rotates the liquid crystal molecules **310** by a predetermined angle with maintaining the liquid crystal molecules **310** substantially parallel with the surface of array substrate **100**. The liquid crystal molecules **310** disposed on the first sub pixel electrode **156a** are rotated in a direction opposite to the rotation direction of the liquid crystal molecules **310** disposed on the second sub pixel electrode **156b**. Since the first and second sub pixel electrodes **156a** and **156b** are tilted in opposite directions, the liquid crystal molecules **310** disposed on the first and second sub pixel electrodes **156a** and **156b** are prevented from colliding with each other.

[0081] In this embodiment, the horizontally aligned liquid crystal molecules **310** of the liquid crystal layer **300** are rotated by the electric field formed between pixel electrode **150** and the common electrode CE by a predetermined angle. Thus, the liquid crystal molecules **310** are not perpendicular to the surface of array substrate **100**, but are parallel with the surface of array substrate **100**. Since the liquid crystal molecules **310** is substantially parallel with the surface of array substrate **100**, the alignment of the liquid crystal molecules **310** may not be changed by the externally applied vertical direction of pressure produced by a pen touching the screen. Thus, the image displayed is not distorted by the touching of the screen with a pen and, accordingly, image quality is improved.

[0082] Furthermore, when the pixel has a rectangular shape, of which a first length in the first direction is longer than a second length in the second direction, the number of data lines DL may be reduced. Thus, the number of data driver chips may be reduced thereby lowering both manufacturing cost and power consumption of the display panel.

[0083] FIG. **10** is a plan view illustrating a portion of an array substrate of a display panel according to another exemplary embodiment of the present invention. FIG. **11** is an enlarged plan view illustrating a region 'R4' of FIG. **10**. FIG. **12** is an enlarged plan view illustrating a region 'R5' of FIG. **10**. FIG. **13** is an enlarged plan view illustrating a region 'R6' of FIG. **10**. FIG. **14** is a cross-sectional view taken along a line IV-IV' of FIG. **13**.

[0084] Referring to FIGS. **1** and **2**, a display panel **400** includes an array substrate **100**, an opposite substrate **200** and a liquid crystal layer **300**.

[0085] Referring to FIGS. **10**, **11**, **12**, **13** and **14**, array substrate **100** includes a first transparent substrate **110**, a gate line GL, a first insulation layer **120**, a data line DL, a thin-film transistor TFT, a common voltage line **130**, a second insulation layer **140**, a pixel electrode **150**, a common electrode **160** and a horizontal connection electrode HE.

[0086] First transparent substrate **110** may have a plate-shape, and may include a transparent material. Gate line GL is formed on first transparent substrate **110**, and extends in a first direction. A plurality of the gate lines GL is arranged in a second direction substantially perpendicular to the first direction. The first insulation layer **120** is formed on first transparent substrate **110** to cover gate line GL. Data line DL is formed on the first insulation layer **120**, and extends in the second direction to cross gate line GL. A plurality of the data lines DL is arranged in the first direction. The data lines DL cross the gate lines GL so that a plurality of pixels is defined. Each of the pixels may have a rectangular shape, of which a first length in the first direction is longer than a second length in the second direction.

[0087] Thin-film transistor TFT is formed in each of the pixels, and is electrically connected to gate line GL, data line DL and pixel electrode **150**. For example, the thin-film transistors TFT electrically connected to one of the data lines DL may be alternatively adjacent to a first side of data line DL and a second side of data line DL, which is opposite to the first side, when viewed from a plan view.

[0088] Referring to FIGS. **10** and **11**, thin-film transistor TFT includes a gate electrode G, an active layer A, a source electrode S, a drain electrode D and an ohmic contact layer (not shown).

[0089] Gate electrode G protrudes from gate line GL by a predetermined length. For example, gate electrode G may protrude from gate line GL in a direction substantially parallel with data line DL.

[0090] The active layer A is formed on the first insulation layer **120**, and is overlapped with gate electrode G. For example, the active layer A may have a rectangular shape, and may include amorphous silicon (a-Si).

[0091] Source electrode S protrudes from data line DL by a predetermined length, and is overlapped with a portion of the active layer A. For example, source electrode S may protrude from data line DL in a direction substantially parallel with gate line GL.

[0092] Drain electrode D is spaced apart from source electrode S by a predetermined distance, and is formed from a layer substantially the same as source electrode S. Drain electrode D is overlapped with a portion of the active layer A. Furthermore, drain electrode D is overlapped with a portion of pixel electrode **150** to be electrically connected to pixel electrode **150**.

[0093] The ohmic contact layer O is formed between source electrode S and the active layer A and between drain electrode D and the active layer A. The ohmic contact layer O may include amorphous silicon (a-Si), into which n+ impurities are implanted at a high concentration.

[0094] Referring to FIG. **10**, the common voltage line **130** extends in the second direction to cross the pixel. A plurality of the common voltage lines **130** is arranged in the second direction. Particularly, the common voltage line **130** may cross a central portion of the pixel. The common voltage line **130** is formed from a layer substantially the same as data line DL. Particularly, the common voltage line **130** is formed on the first insulation layer **130**.

[0095] The second insulation layer **140** is formed on the first insulation layer **120** to cover thin-film transistor TFT, data line DL and the common voltage line **130**.

[0096] Pixel electrode **150** is formed on the second insulation layer **140** in each of the pixels. Pixel electrode **150** is electrically connected to drain electrode D of thin-film

transistor TFT through a pixel contact hole **142** formed through the second insulation layer **140**. Pixel electrode **150** includes a transparent conductive material.

[0097] Referring to FIG. **10**, pixel electrode **150** includes a main pixel electrode **152** and a sub pixel electrode **154**. Pixel electrode **150** may be substantially symmetric with respect to a central line of the pixel, which is substantially parallel with the second direction.

[0098] The main pixel electrode **152** is adjacent to one of the gate lines GL, and extends in the first direction.

[0099] The sub pixel electrode **154** protrudes from the main pixel electrode **152** in a direction opposite to the one of the gate lines GL. A plurality of the sub pixel electrodes **154** may be arranged in the first direction.

[0100] The sub pixel electrode **154** may be substantially symmetric with respect to the central line of the pixel. For example, the sub pixel electrode **154** may include a first sub pixel electrode **154a** and a second sub pixel electrode **154b**, which are substantially symmetric with respect to the central line of the pixel.

[0101] The first sub pixel electrode **154a** is adjacent to a first side of the central line of the pixel, and may be tilted by a predetermined angle with respect to the second direction. For example, the first sub pixel electrode **154a** may be tilted with respect to the second direction by about 0.5 to about 5 degrees.

[0102] The second sub pixel electrode **154b** is adjacent to a second side of the central line of the pixel, which is opposite to the first side, and may be tilted so that the first and second sub pixel electrodes **154a** and **154b** are substantially symmetric with respect to the central line of the pixel. Particularly, the second sub pixel electrode **154b** may be tilted with the second direction by about 0.5 to about 5 degrees in a direction opposite to the first sub pixel electrode **154a**.

[0103] Referring to FIGS. **10** and **12**, common electrode **160** is formed from a layer substantially the same as pixel electrode **150**. Particularly, common electrode **160** is formed on the second insulation layer **140** in each of the pixels, and is electrically insulated from pixel electrode **150**. Common electrode **160** is electrically connected to the common voltage line **130** through a common contact hole **144** formed through the second insulation layer **140**. Common electrode **160** may include a transparent conductive material substantially the same as pixel electrode **150**.

[0104] Particularly, common electrode **160** includes a main common electrode **162** and a sub common electrode **164**. Common electrode **160** may be substantially symmetric with respect to the central line of the pixel.

[0105] The main common electrode **162** extends in the first direction to face the main pixel electrode **152**. Particularly, the main common electrode **162** is adjacent to the consecutive one of the gate lines GL.

[0106] The sub common electrode **164** protrudes from the main common electrode **162** toward the main pixel electrode **152** without overlapping with the sub pixel electrode **154**. A plurality of the sub common electrodes **164** is arranged in the first direction.

[0107] The sub common electrode **164** may be substantially symmetric with respect to the central line of the pixel. Particularly, the sub common electrode **164** includes a first sub common electrode **164a** and a second sub common electrode **164b**, which are symmetric with respect to the central line of the pixel.

[0108] The first sub common electrode **164a** is adjacent to a first side of the central line of the pixel, and may be tilted in a direction substantially the same as the first sub pixel electrode **154a**. For example, the first sub common electrode **164a** may be tilted with the second direction by about 0.5 to about 5 degrees. The number of the first sub common electrodes **164a** may be the same as the number of the first sub pixel electrodes **154a**. The first sub common electrode **164a** may be disposed between the first sub pixel electrodes **154a** adjacent to each other.

[0109] The second sub common electrode **164b** is adjacent to a second side of the central line of the pixel, which is opposite to the first side, and may be tilted in a direction substantially the same as the second sub pixel electrode **154b**. Particularly, the second sub common electrode **164b** is tilted with the second direction by about 0.5 to about 5 degrees in a direction opposite to the first sub common electrode **164a**. The number of the second sub common electrodes **164b** may be the same as the number of the second sub pixel electrodes **154b**. The second sub common electrode **164b** may be disposed between the second sub pixel electrodes **154b** adjacent to each other.

[0110] Referring to FIG. 12, common electrode **160** may further include a vertical connection electrode **162a** electrically connected to the common voltage line **130**. Furthermore, the common voltage line **130** has a common voltage connection portion **132** electrically connected to common electrode **160**. A common contact hole **144** is formed through the second insulation layer **140** to expose a portion of the common voltage connection portion **132**.

[0111] Particularly, the vertical connection electrode **162a** protrudes from the main common electrode **162** along the common voltage line **130** by a predetermined length. Thus, the vertical connection electrode **162a** is overlapped with the common voltage connection portion **132**, and is electrically connected to the common voltage connection portion **132** through the common contact hole **132**.

[0112] The horizontal connection electrode HE is disposed between the common electrodes **160** adjacent to each other to electrically connect the common electrodes **160** to each other. The horizontal connection electrode HE is formed from a layer substantially the same as common electrode **160**. Particularly, the horizontal connection electrode HE is formed on the second insulation layer **140**, and may include a transparent conductive material.

[0113] Array substrate **100** further includes a first alignment layer (not shown) to align the liquid crystal layer **300** in a predetermined direction. The first alignment layer is formed on the second insulation layer **140** to cover pixel electrode **150** and common electrode **160**.

[0114] In this embodiment, pixel electrode **150** is disposed on common electrode **160** when viewed from a plan view. Alternatively, common electrode **160** may be disposed on pixel electrode **150** when viewed from a plan view.

[0115] Hereinafter, the opposite substrate **200** and the liquid crystal layer **300** will be described more fully with reference to FIGS. 1, 2, 10, 13 and 14.

[0116] The opposite substrate **200** faces array substrate **100**. The opposite substrate **200** includes a second transparent substrate **210** and a light-blocking layer (not shown). The opposite substrate **200** may further include a color filter **220**.

[0117] The second transparent substrate **210** may include a transparent material substantially the same as the first transparent substrate **140**, and may have a plate-shape.

[0118] The light-blocking layer is formed on the second transparent substrate **210** to face array substrate **100**. The light-blocking layer may be large enough to cover gate line GL, data line DL and thin-film transistor TFT.

[0119] The color filter **220** is formed on the second transparent substrate **210**, and is overlapped with pixel electrode **150**. Alternatively, the color filter **220** may be formed on array substrate **100**.

[0120] The opposite substrate **100** may further include a second alignment layer (not shown) to align the liquid crystal molecules **310** of the liquid crystal layer **300** in a predetermined direction. The second alignment layer covers the color filter **220**.

[0121] The liquid crystal layer **300** is interposed between array substrate **100** and the opposite substrate **200**. The liquid crystal molecules **310** of the liquid crystal layer **300** are aligned by the first and second alignment layers in a predetermined direction. Particularly, the liquid crystal molecules **310** may be aligned substantially parallel with a surface of array substrate **100** in the second direction.

[0122] When a first voltage is applied to common electrode **160**, and a second voltage having a voltage level different from the first voltage is applied to pixel electrode **150**, an electric field is formed between common electrode **160** and pixel electrode **150**. The electric field rotates the liquid crystal molecules **310** by a predetermined angle while maintaining the liquid crystal molecules **310** substantially parallel with the surface of array substrate **100**. The liquid crystal molecules **310** disposed on the first sub pixel electrode **156a** are rotated in a direction opposite to a rotation direction of the liquid crystal molecules **310** disposed on the second sub pixel electrode **156b**. Since the first and second sub pixel electrodes **156a** and **156b** are tilted in an opposite direction, the liquid crystal molecules **310** disposed on the first and second sub pixel electrodes **156a** and **156b** are prevented from colliding with each other.

[0123] According to the above, an array substrate includes a pixel electrode and a common electrode so that the horizontally aligned liquid crystal molecules of a liquid crystal layer are rotated by an electric field formed between the pixel electrode and the common electrode by a predetermined angle. Thus, the liquid crystal molecules are not perpendicular to the surface of the array substrate, but parallel with the surface of the array substrate. Therefore, the alignment of the liquid crystal molecules is not changed by an externally applied pressure from a pen touching the screen and display quality is thereby improved.

[0124] Furthermore, the pixel has a rectangular shape in which a first length in a row direction is longer than a second direction in a column direction. Thus, the number of data lines DL may be reduced. Therefore, the number of data driver chips may be reduced so that a manufacturing cost and power consumption of the display panel are reduced.

[0125] Although the exemplary embodiments of the present invention have been described, it is understood that the present invention should not be limited to these exemplary embodiments but various changes and modifications can be made by one ordinary skilled in the art within the spirit and scope of the present invention as hereinafter claimed.

What is claimed is:

1. An array substrate comprising:
 - a plurality of gate lines extending in a first direction;
 - a plurality of data lines extending in a second direction substantially perpendicular to the first direction, the intersecting directions of the data lines and gate lines defining a plurality of pixels;
 - a plurality of thin-film transistors electrically connected to the gate lines and the data lines;
 - a pixel electrode electrically connected to each of the thin-film transistors;
 - a common voltage line extending in the second direction substantially parallel with the data lines; and
 - a common electrode formed in each of the pixels, electrically insulated from the pixel electrode, and electrically connected to the common voltage line.
2. The array substrate of claim 1, wherein the pixel electrode and the common electrode comprise a transparent conductive material.
3. The array substrate of claim 2, wherein the pixel electrode comprises:
 - a first main pixel electrode that extends in the first direction adjacent to one of the gate lines;
 - a second main pixel electrode extending in the first direction and spaced apart from the first main pixel electrode and adjacent to a consecutive one of the gate lines; and
 - a plurality of sub pixel electrodes disposed between the first and second main pixel electrodes to connect the first and second main pixel electrodes, the sub pixel electrodes being arranged in the first direction.
4. The array substrate of claim 3, further comprising an insulation layer formed between the common electrode and the pixel electrode, wherein the common electrode is disposed under the pixel electrode.
5. The array substrate of claim 4, wherein the common electrode is larger than the pixel electrode to cover the pixel electrode when viewed from a plan view.
6. The array substrate of claim 3, wherein the sub pixel electrode is symmetric with respect to a central line of the pixel which is substantially parallel with the second direction.
7. The array substrate of claim 6, wherein the sub pixel electrodes comprise:
 - a first sub pixel electrode that is adjacent to a first side of the central line, and is tilted at a predetermined angle to the second direction; and
 - a second sub pixel electrode that is adjacent to a second side of the central line, which is opposite to the first side, and is tilted by a predetermined angle to the second direction so that the first and second sub pixel electrodes are symmetric to the central line.
8. The array substrate of claim 3, further comprising:
 - a first insulation layer formed between the common electrode and the common voltage line;
 - a second insulation layer formed between the common voltage line and the pixel electrode;
 - a vertical connection electrode that is formed on the second insulation layer, and is electrically insulated from the pixel electrode; and
 - a contact hole formed through the first and second insulation layers, wherein the common voltage line is disposed in the common electrode, and the pixel electrode is disposed on the common voltage line, and the common voltage line has a common voltage connection portion electrically connected to the common electrode, and the vertical connection electrode electrically connects the common voltage connection portion to the common electrode through the contact hole.
9. The array substrate of claim 8, wherein the common voltage connection portion is symmetric with respect to a central line of the pixel, which is substantially parallel with the second direction.
10. The array substrate of claim 2, wherein the pixel electrode comprises:
 - a main pixel electrode that extends in the first direction, and is adjacent to one of the gate lines; and
 - a plurality of sub pixel electrodes protruding from the main pixel electrode toward a consecutive one of the gate lines, the sub pixel electrodes being arranged in the first direction.
11. The array substrate of claim 10, wherein the common electrode comprises:
 - a main common electrode that extends in the first direction, and is adjacent to a consecutive one of the gate lines; and
 - a plurality of sub common electrodes protruding from the main common electrode toward the main pixel electrode, the sub common electrodes being arranged in the first direction.
12. The array substrate of claim 11, wherein the common electrode is formed from a layer substantially the same as the pixel electrode.
13. The array substrate of claim 11, wherein the sub pixel electrodes are symmetric with respect to a central line of the pixel, which is substantially parallel with the second direction, and the sub common electrodes are symmetric with respect to the central line.
14. The array substrate of claim 13, wherein the sub pixel electrodes comprise:
 - a first sub pixel electrode that is adjacent to a first side of the central line, and is tilted at a predetermined angle to the second direction; and
 - a second sub pixel electrode that is adjacent to a second side of the central line, which is opposite to the first side, and is tilted at a predetermined angle to the second direction so that the first and second sub pixel electrodes are symmetric with respect to the central line, and the sub common electrodes comprise:
 - a first sub common electrode that is adjacent to a first side of the central line, and is substantially parallel with the first sub pixel electrode; and
 - a second sub common electrode that is adjacent to a second side of the central line, which is opposite to the first side, and is substantially parallel with the second sub pixel electrode.
15. The array substrate of claim 11, further comprising an insulation layer that is formed between the common electrode and the pixel electrode, and has a contact hole, wherein the common electrode is disposed under the pixel electrode, and is electrically connected to the common voltage line through the contact hole.
16. The array substrate of claim 2, further comprising a horizontal connection electrode to electrically connect adjacent common electrodes to each other.

17. The array substrate of claim 2, wherein each of the pixels has a rectangular shape, of which a first length in the first direction is longer than a second direction in the second direction.

18. The array substrate of claim 17, wherein the thin-film transistors electrically connected to one of data lines are alternatively adjacent to a first side of the data line and a second side of the data line opposite to the first side.

19. A display panel comprising:

an array substrate that comprises:

a plurality of gate lines extending in a first direction;

a plurality of data lines extending in a second direction substantially perpendicular to the first direction;

a plurality of thin-film transistors electrically connected to the gate line and the data line;

a pixel electrode formed in each of pixels defined by the gate lines and the data lines and electrically connected to each of the thin-film transistors;

a common voltage line extending in the second direction substantially parallel with the data line; and

a common electrode formed in each of the pixels electrically insulated from the pixel electrode and electrically connected to the common voltage line;

an opposite substrate facing the array substrate; and

a liquid crystal layer interposed between the array substrate and the opposite substrate and having liquid crystal molecules.

20. The display panel of claim 19, wherein the liquid crystal molecules of the liquid crystal layer are aligned substantially parallel with a surface of the array substrate, and are rotated by an electric field formed by the pixel electrode and the common electrode by a predetermined angle with being substantially parallel with the surface of the array substrate.

* * * * *

专利名称(译)	抗扭曲的触摸显示面板		
公开(公告)号	US20080024712A1	公开(公告)日	2008-01-31
申请号	US11/744696	申请日	2007-05-04
[标]申请(专利权)人(译)	金东GYU		
申请(专利权)人(译)	金东GYU		
当前申请(专利权)人(译)	金东GYU		
[标]发明人	KIM DONG GYU		
发明人	KIM, DONG-GYU		
IPC分类号	G02F1/1343 H01L27/105		
CPC分类号	G02F1/13338 G06F3/0412 G02F1/136286 G02F1/134363		
优先权	1020060069444 2006-07-25 KR		
其他公开文献	US7649605		
外部链接	Espacenet USPTO		

摘要(译)

阵列基板包括多条栅极线，多条数据线，多个薄膜晶体管，多个像素电极，多条公共电压线和多个公共电极。栅极线沿第一方向延伸。数据线在基本垂直于第一方向的第二方向上延伸。薄膜晶体管电连接到栅极线和数据线。像素电极形成在由栅极线和数据线限定的每个像素中。公共电极电连接到公共电压线。通过外部施加的垂直触摸压力不改变液晶分子的水平排列，从而提高显示质量。

