



US007557892B2

(12) **United States Patent**
Kim et al.

(10) **Patent No.:** **US 7,557,892 B2**
(45) **Date of Patent:** **Jul. 7, 2009**

(54) **LIQUID CRYSTAL DISPLAY DEVICE HAVING SPACERS OVERLAPPED WITH SLITS IN THE COMMON LINE AND GATE LINE**

(75) Inventors: **Jong Woo Kim**, Paju-si (KR); **Won Hyung Yoo**, Seoul (KR)

(73) Assignee: **LG Display Co., Ltd.**, Seoul (KR)

(*) Notice: Subject to any disclaimer, the term of this patent is extended or adjusted under 35 U.S.C. 154(b) by 0 days.

(21) Appl. No.: **11/267,265**

(22) Filed: **Nov. 7, 2005**

(65) **Prior Publication Data**

US 2006/0146222 A1 Jul. 6, 2006

(30) **Foreign Application Priority Data**

Dec. 30, 2004 (KR) 10-2004-0116284

(51) **Int. Cl.**

G02F 1/1339 (2006.01)
G02F 1/1343 (2006.01)

(52) **U.S. Cl.** **349/155**; 349/156; 349/157; 349/139; 349/141

(58) **Field of Classification Search** 349/141, 349/155-157, 139, 145
See application file for complete search history.

(56) **References Cited**

U.S. PATENT DOCUMENTS

5,622,814 A * 4/1997 Miyata et al. 430/314
6,091,473 A * 7/2000 Hebiguchi 349/141
6,172,728 B1 * 1/2001 Hiraishi 349/139

6,805,308 B2 * 10/2004 Kweon et al. 239/583
6,897,935 B2 * 5/2005 Matsumoto et al. 349/157
7,046,327 B2 * 5/2006 Okamoto et al. 349/155
7,133,103 B2 * 11/2006 Park et al. 349/141
7,133,108 B2 * 11/2006 Shimizu et al. 349/155
2004/0046922 A1 * 3/2004 Yanagawa et al. 349/155
2005/0046779 A1 * 3/2005 Sumi et al. 349/155
2005/0140914 A1 * 6/2005 Sawasaki et al. 349/155

FOREIGN PATENT DOCUMENTS

JP 2004-046123 2/2004
KR 1020040101087 A 12/2004

* cited by examiner

Primary Examiner—Andrew Schechter

Assistant Examiner—Lauren Nguyen

(74) *Attorney, Agent, or Firm*—McKenna Long & Aldridge LLP

(57) **ABSTRACT**

An LCD device is disclosed in which column spacers for a cell gap are arranged between gate and common lines to reduce a contact area between the column spacers and an opposing substrate, and a stable cell gap is maintained over the whole panel by reducing variation of a thickness per area of a thin film transistor (TFT) substrate corresponding to the column spacers. The LCD device includes first and second substrates facing each other, gate and data lines formed on the first substrate to cross each other, and pixel regions, a thin film transistor formed in each portion where the gate and data lines cross, common and pixel electrodes alternately formed in the pixel regions, common lines formed adjacent to the gate lines substantially parallel to the gate lines, a first column spacer formed on the second substrate corresponding to a portion between the gate line and the common line, and a liquid crystal layer filled between the first and second substrates.

1 Claim, 16 Drawing Sheets

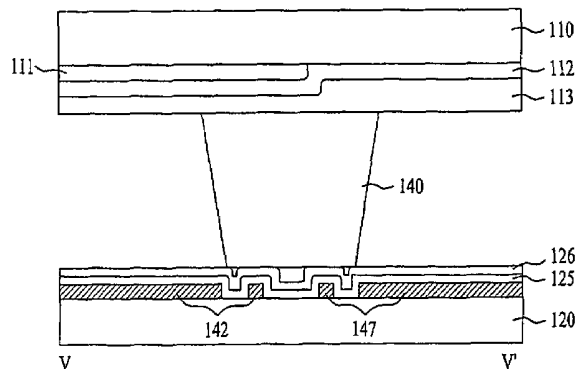
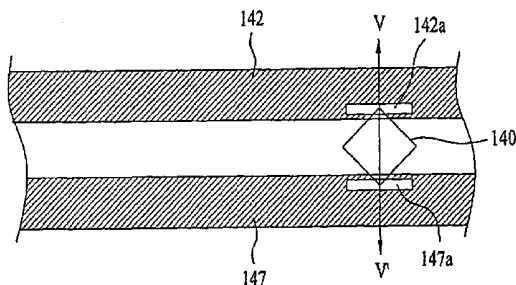

FIG. 1
Related Art

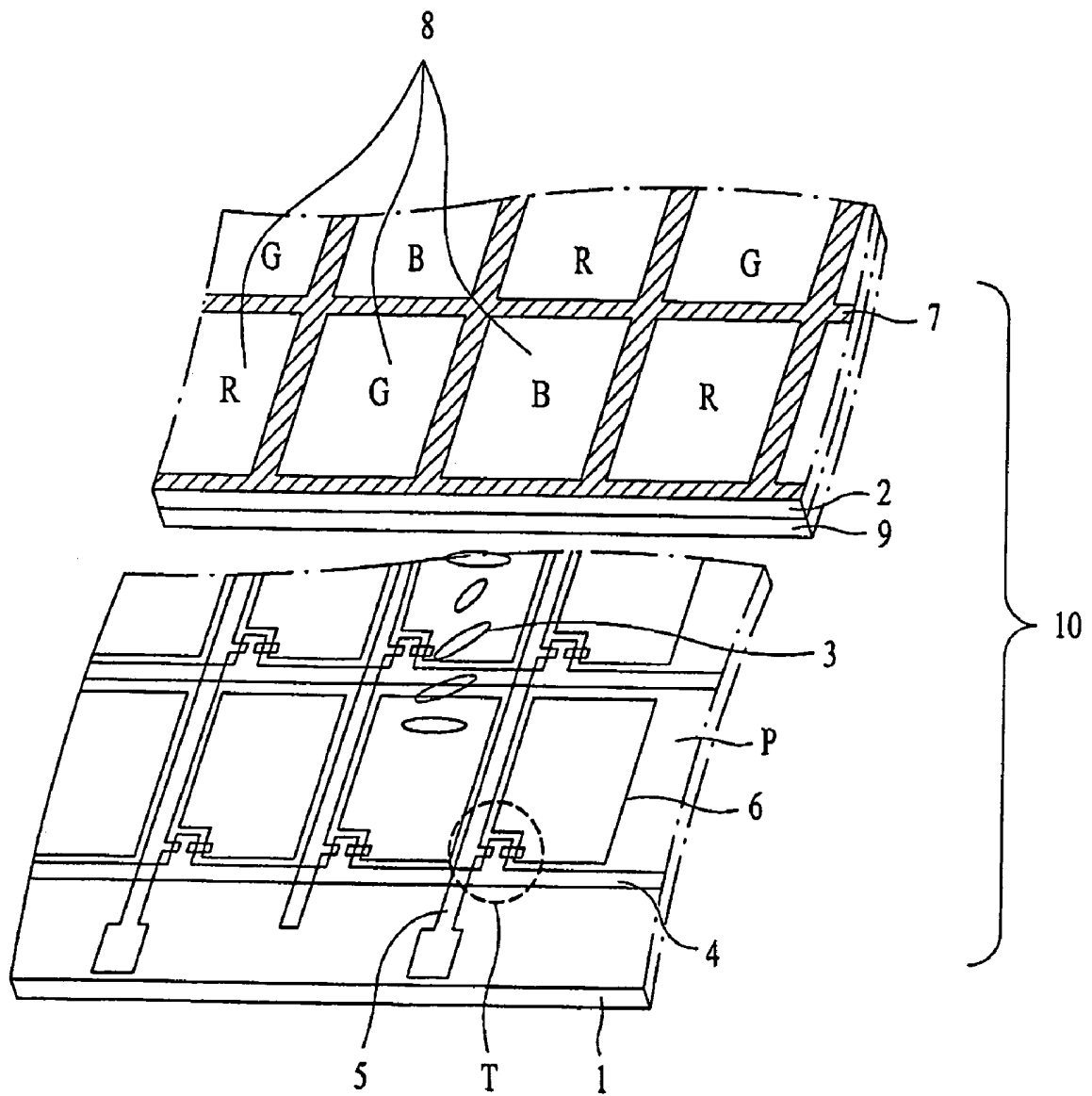

FIG. 2A
Related Art

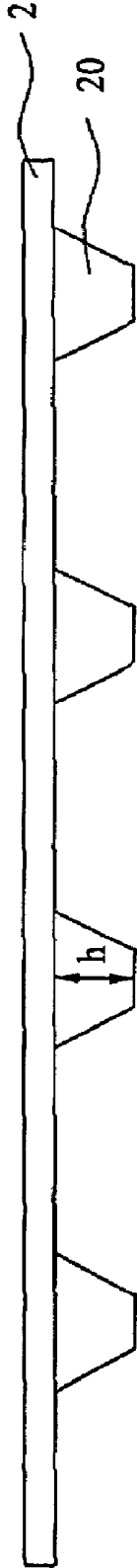

FIG. 2B
Related Art

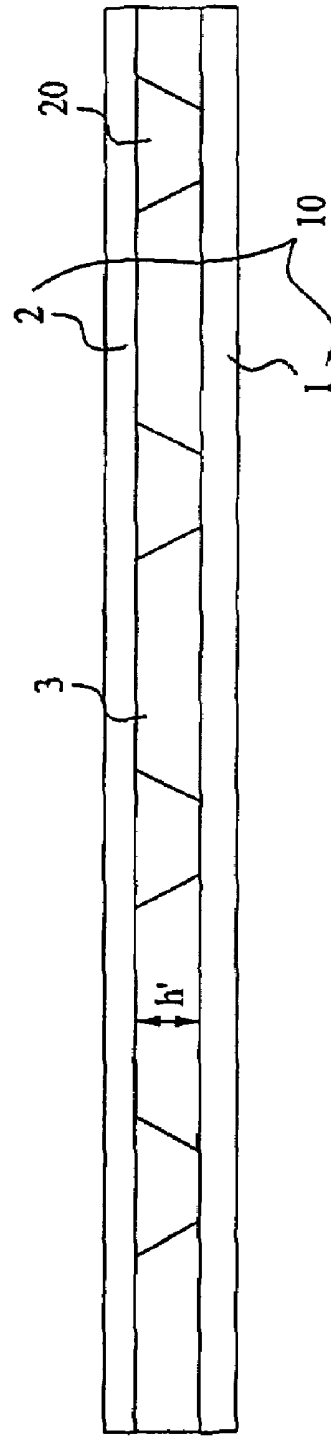

FIG. 3A
Related Art

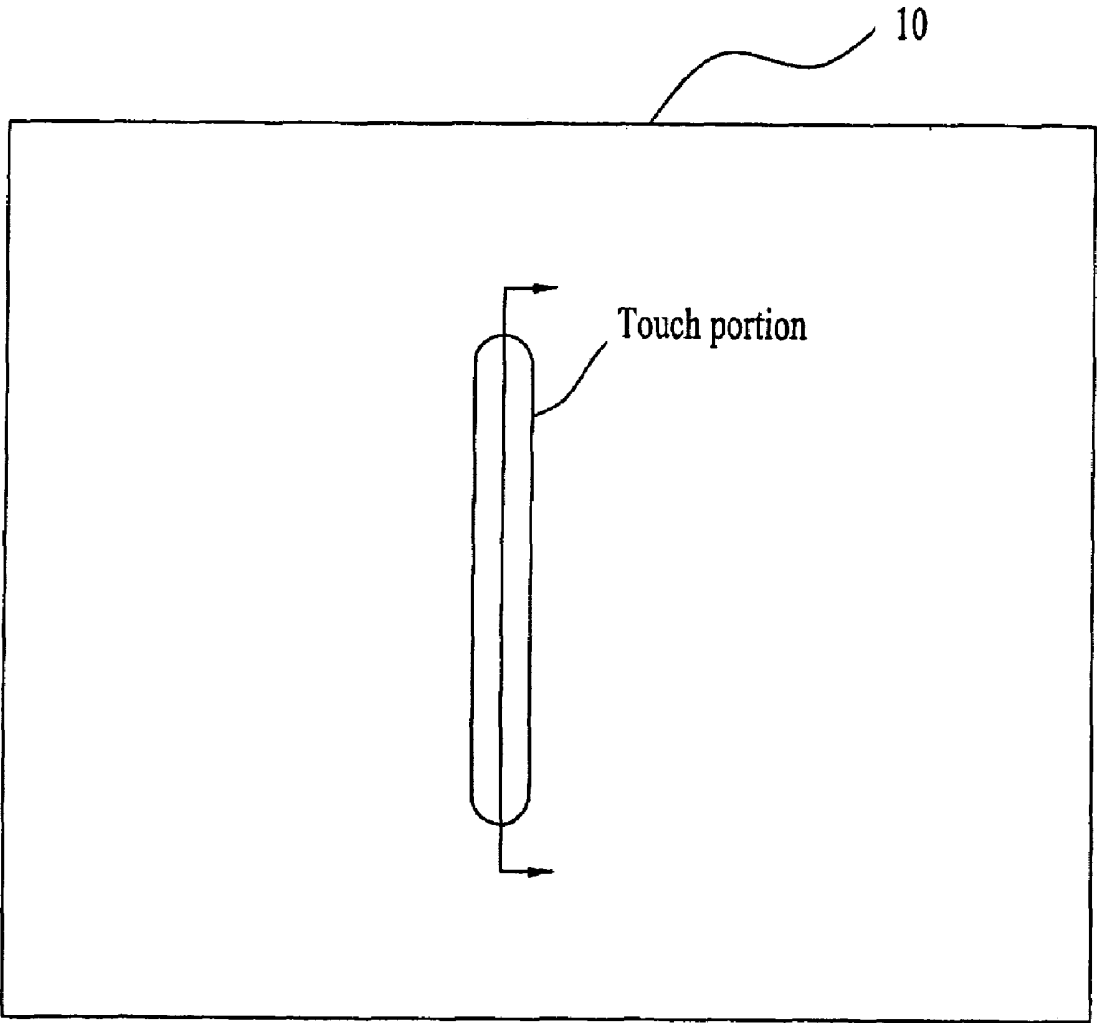
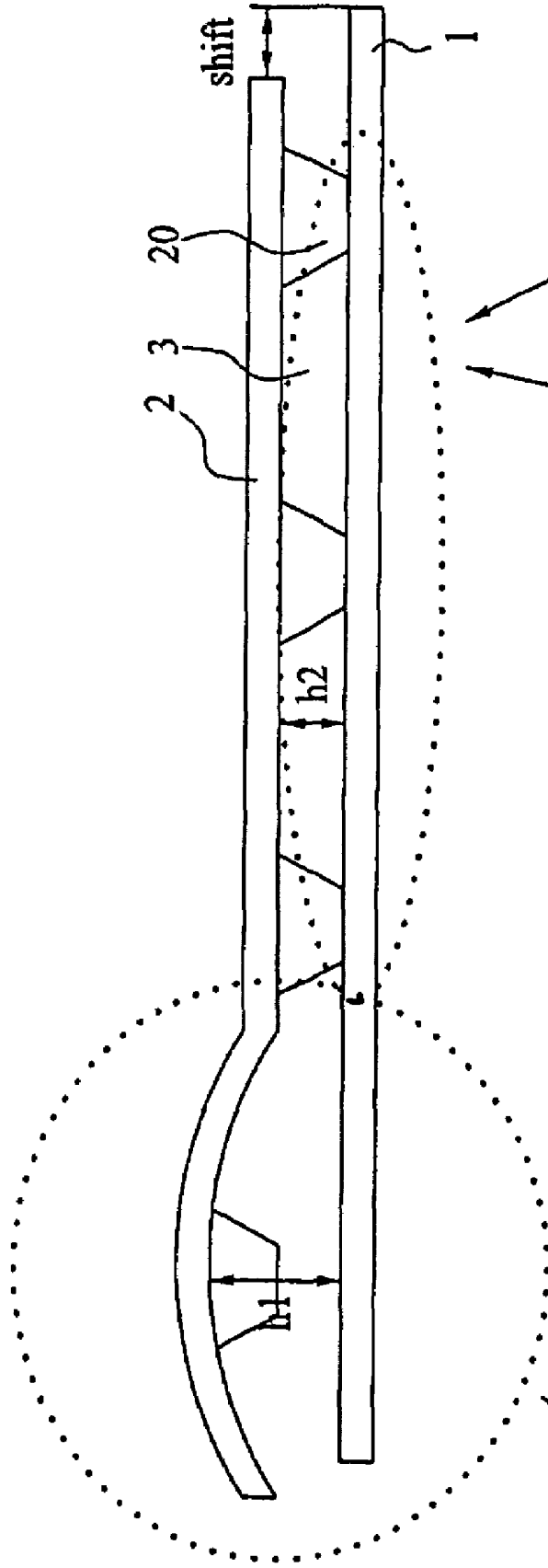

FIG. 3B
Related Art



Liquid crystal molecules are not restored to the original state due to contact area of spacers

Liquid crystal molecules are gathered

FIG. 4

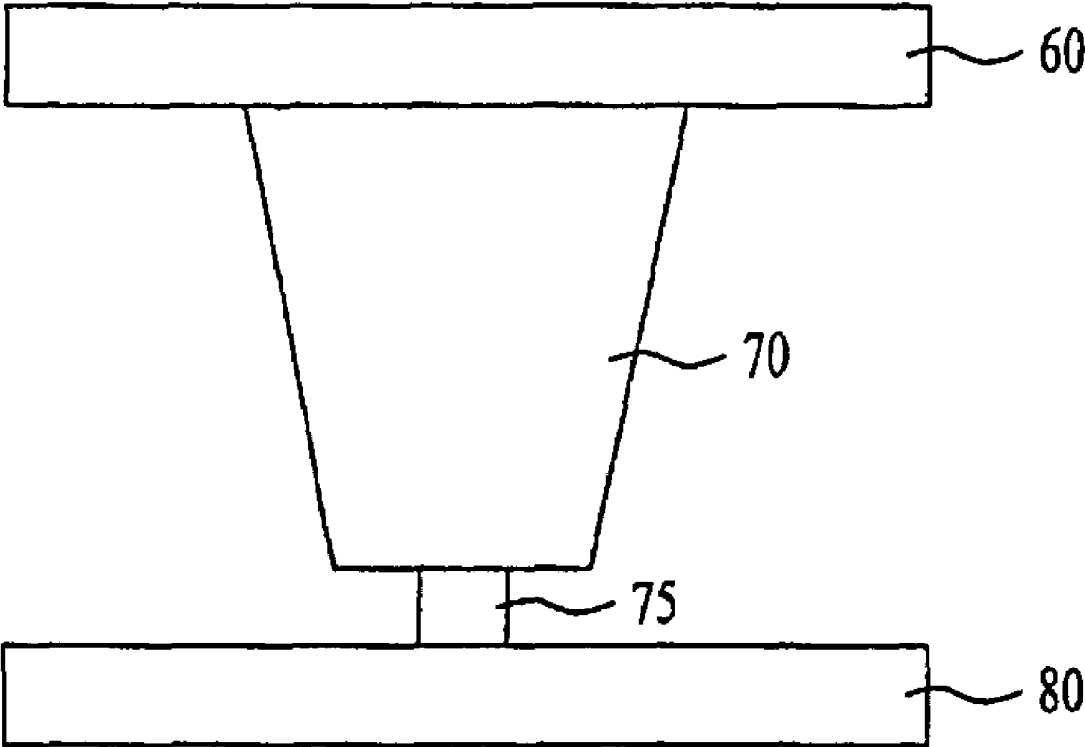

FIG. 5

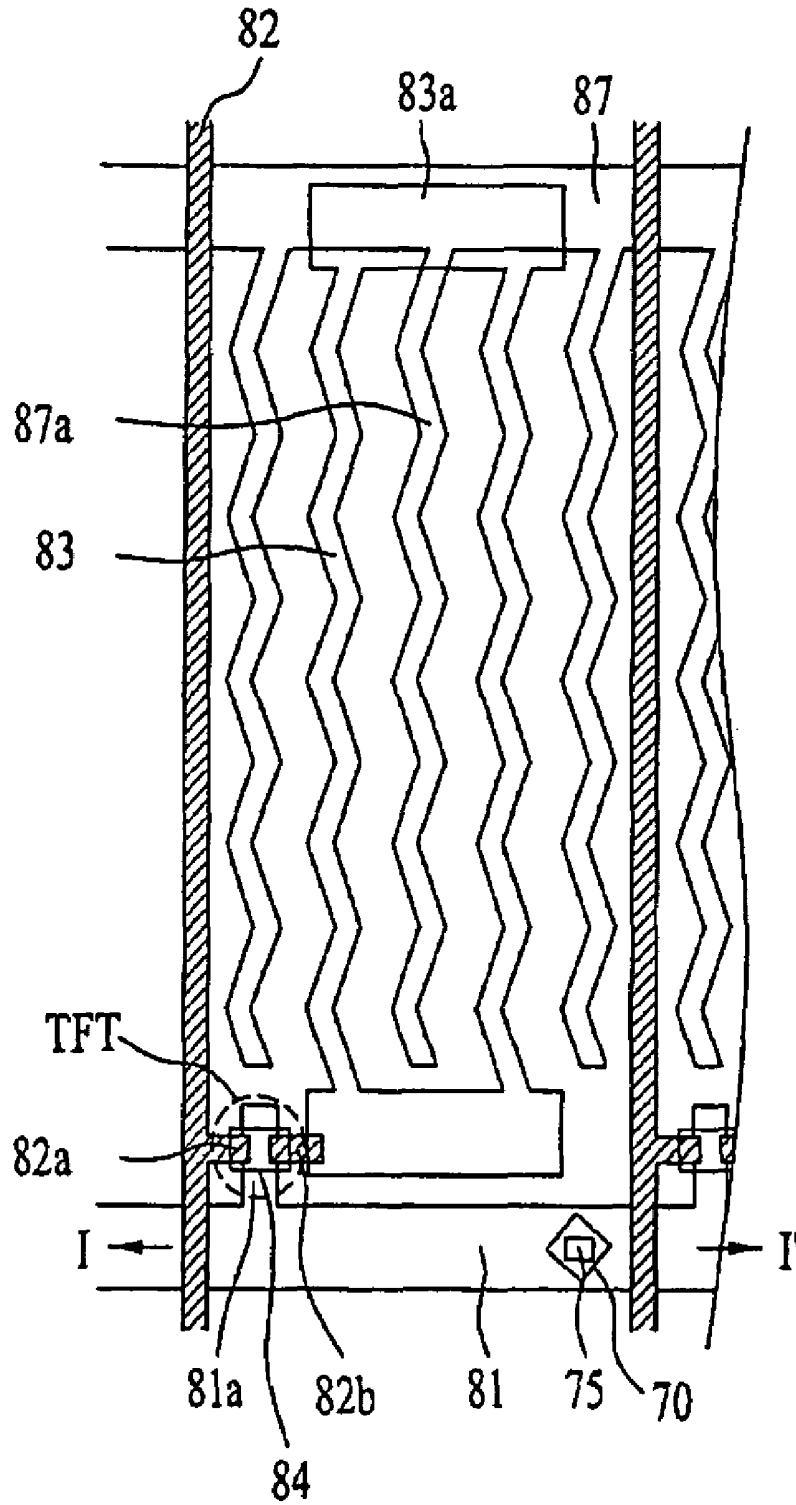

FIG. 6

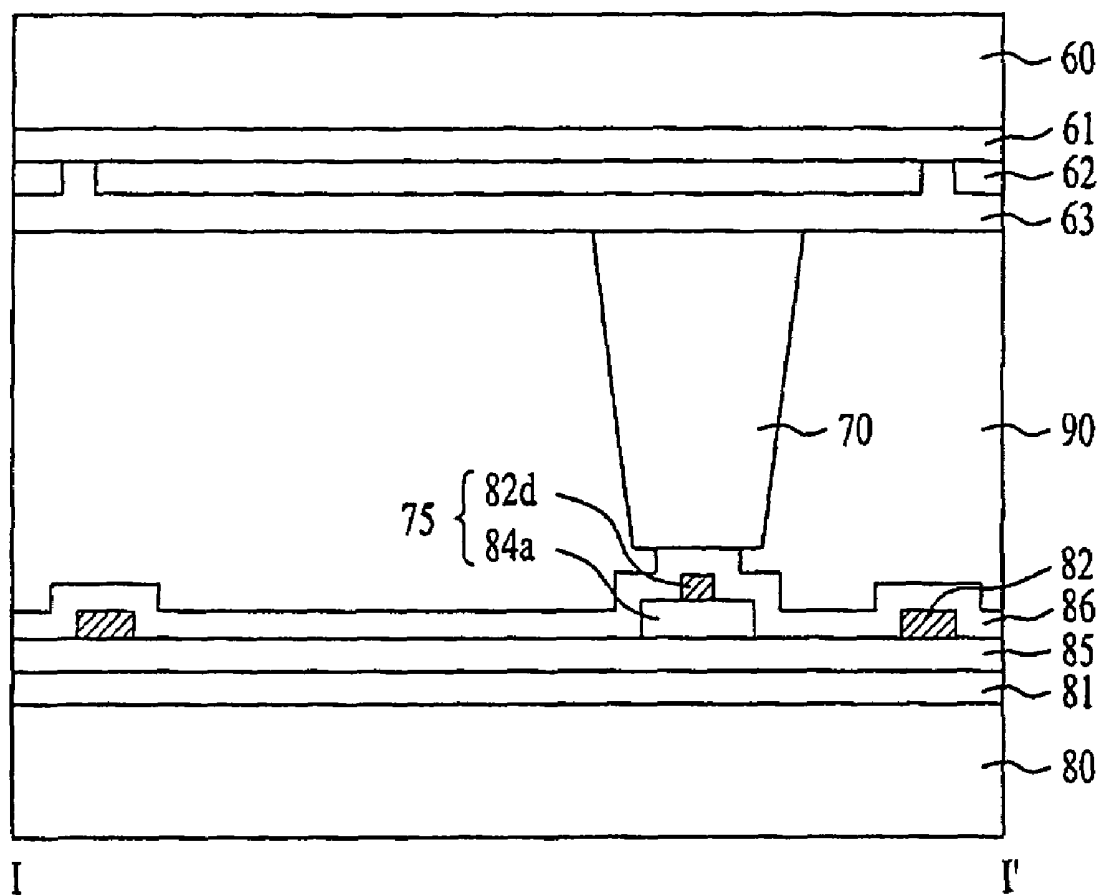

FIG. 7A

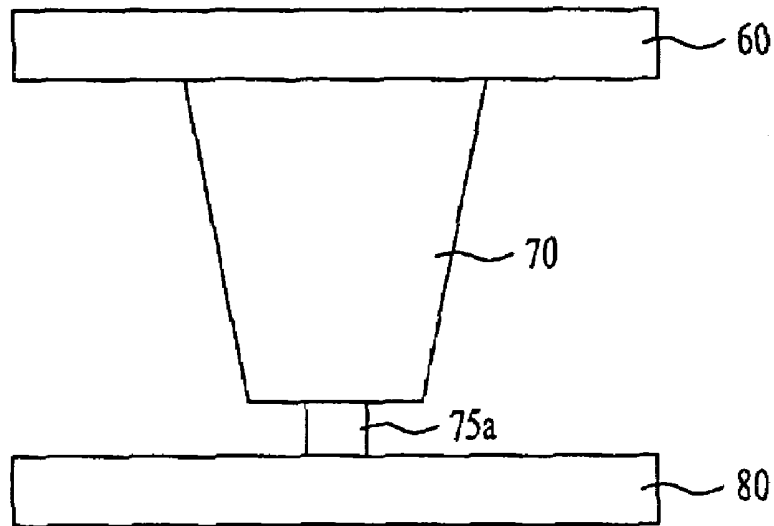

FIG. 7B

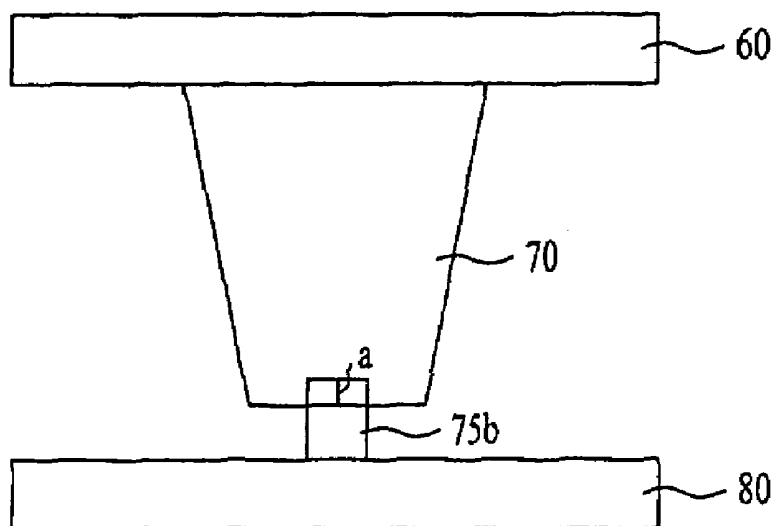

FIG. 8

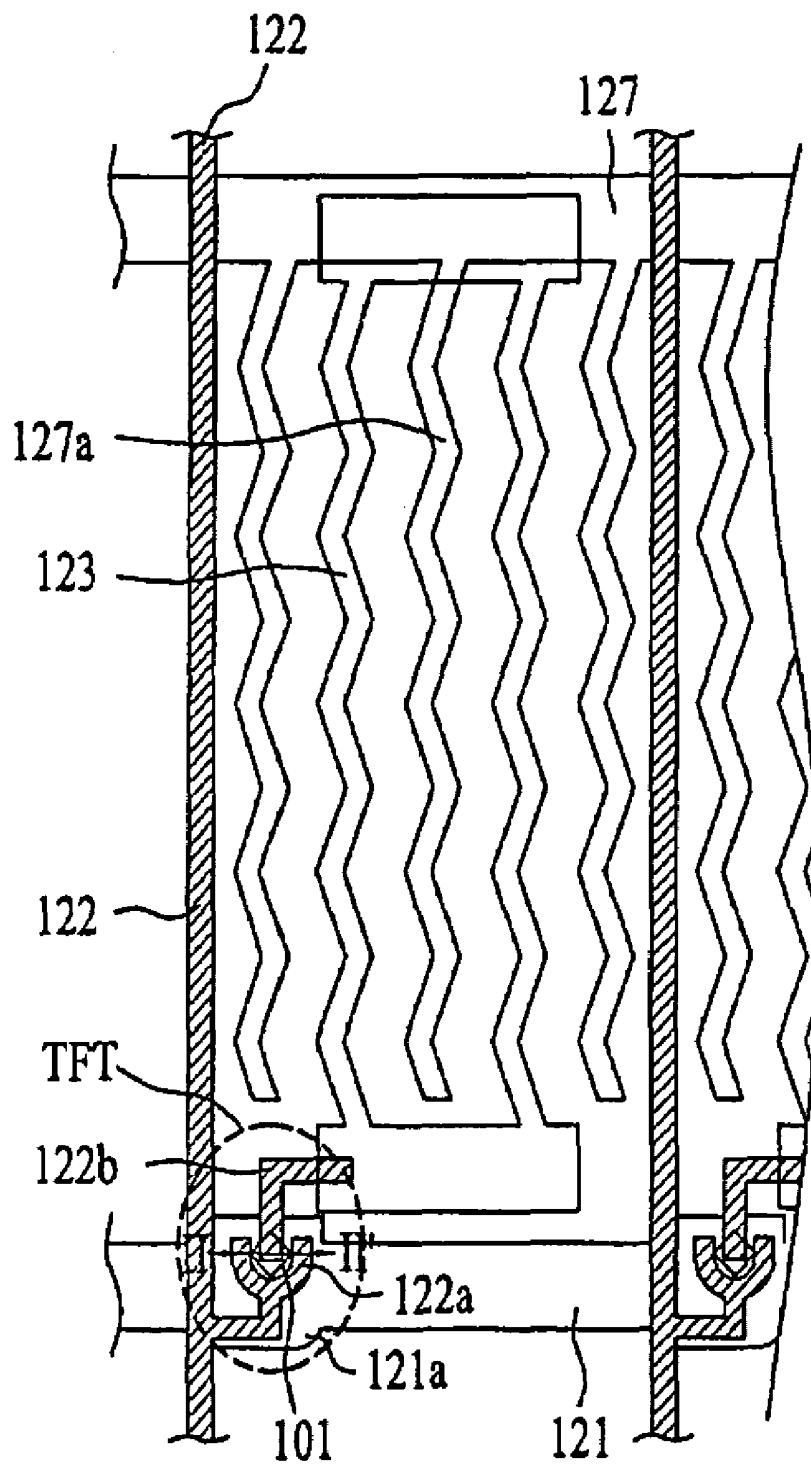

FIG. 9

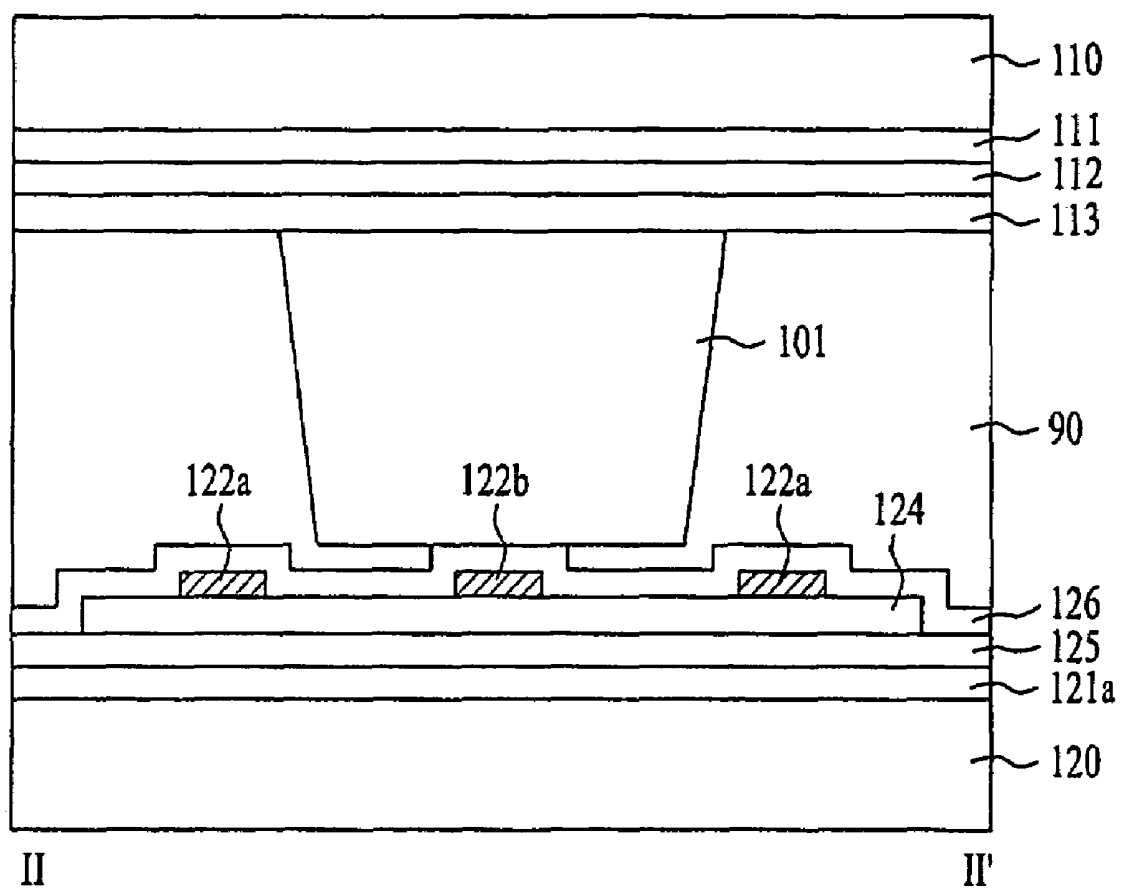

FIG. 10

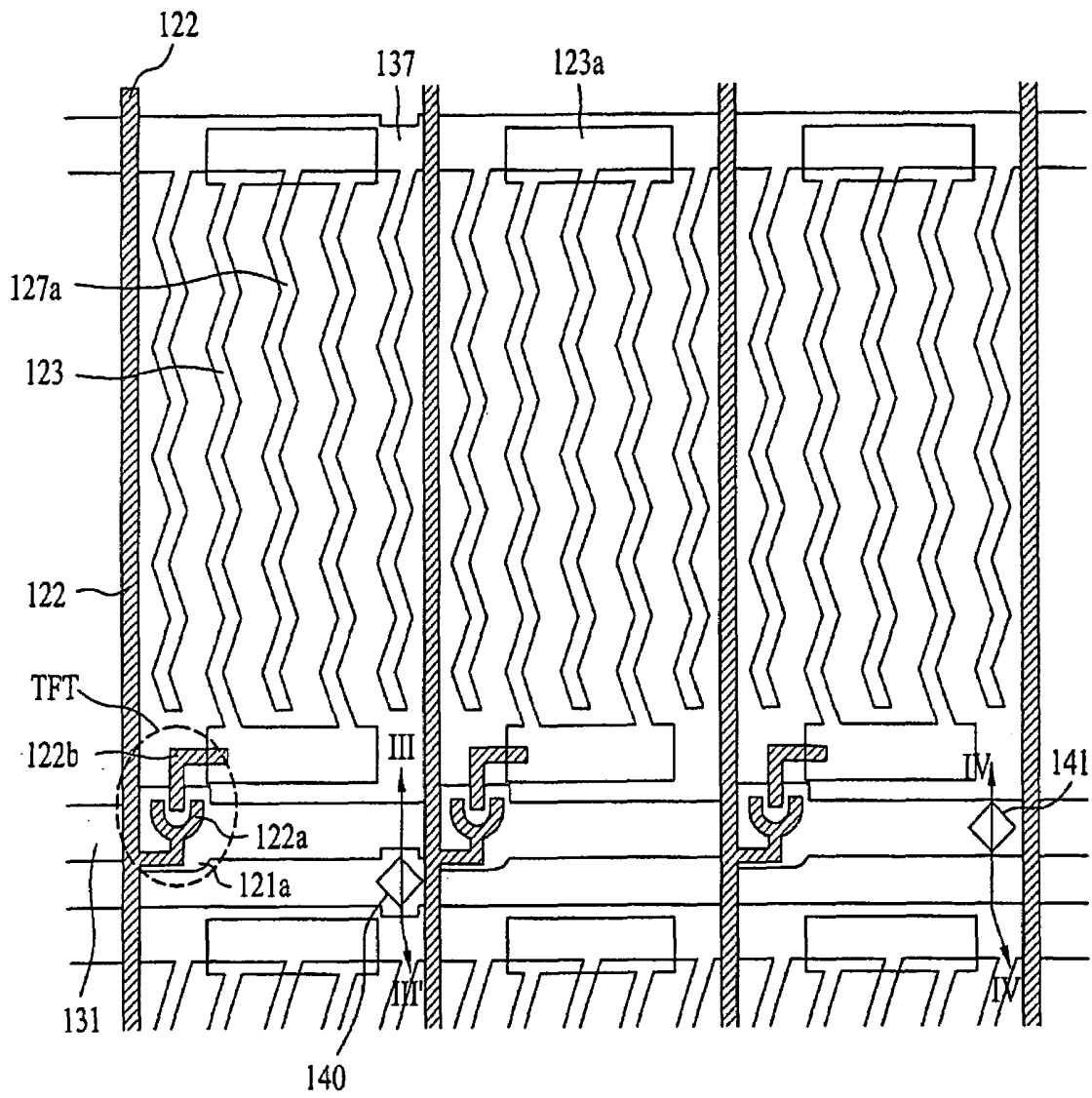

FIG. 11A

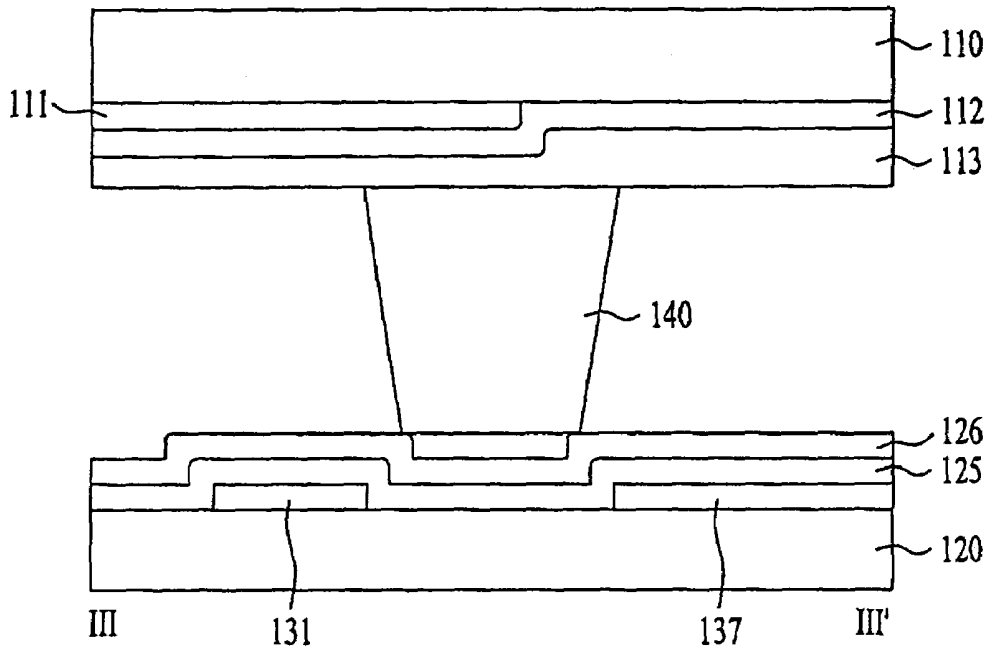

FIG. 11B

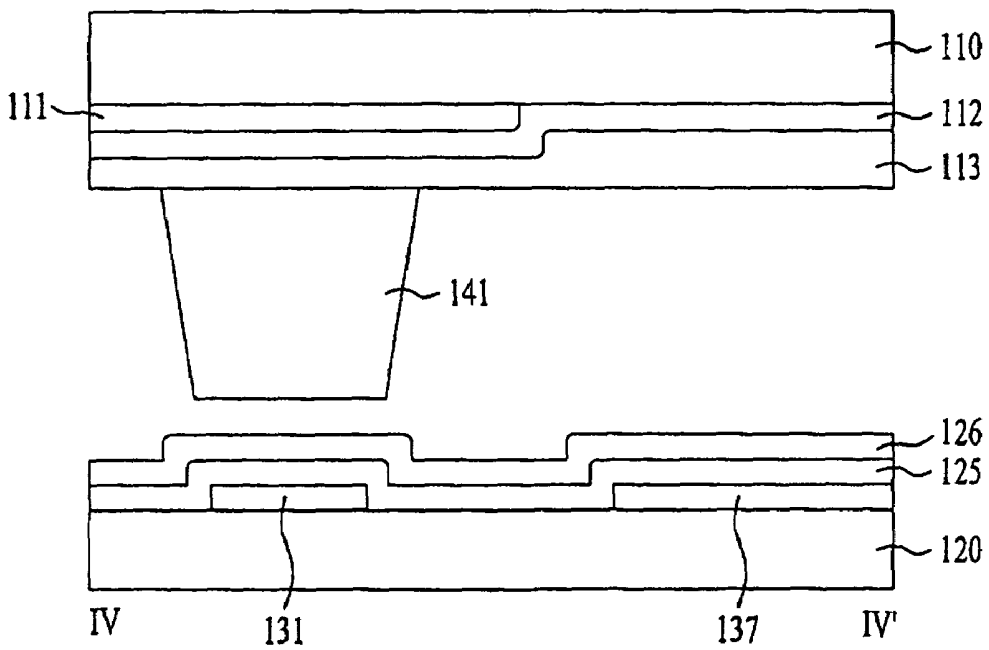

FIG. 12

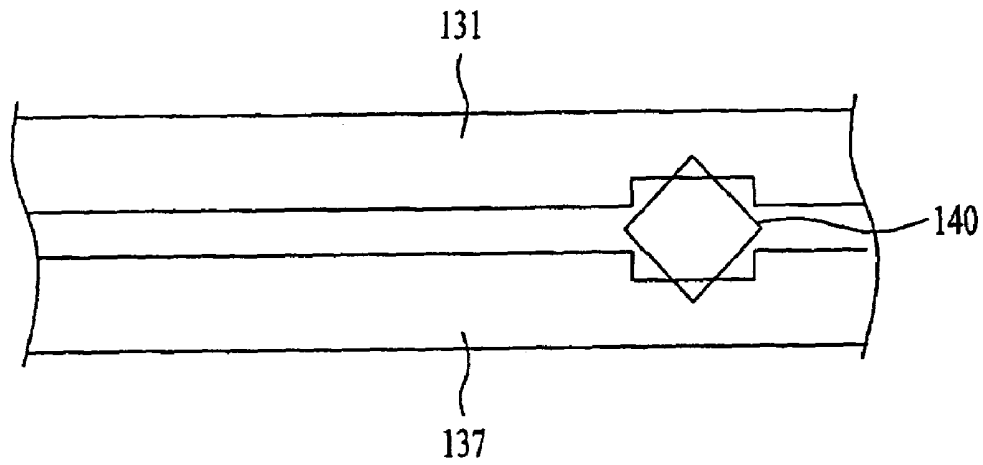

FIG. 13

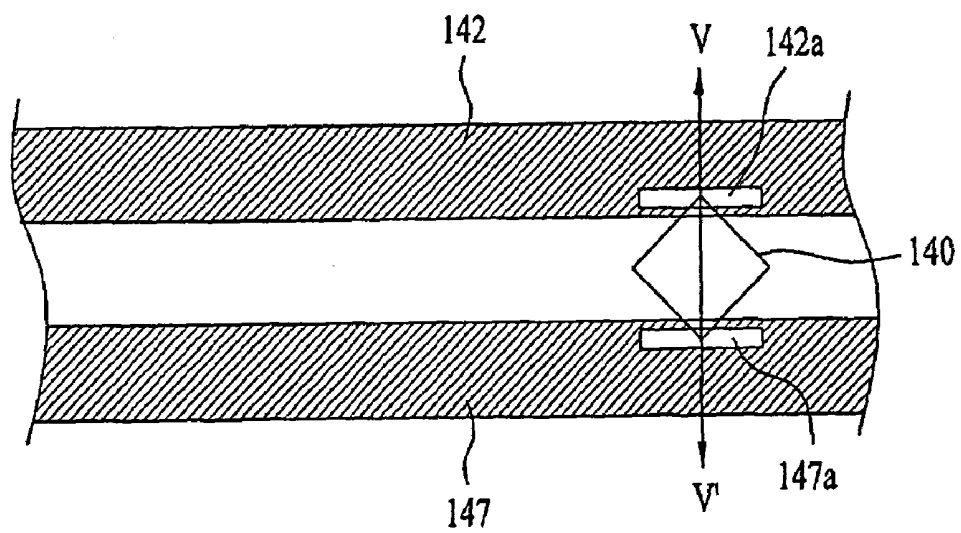

FIG. 14

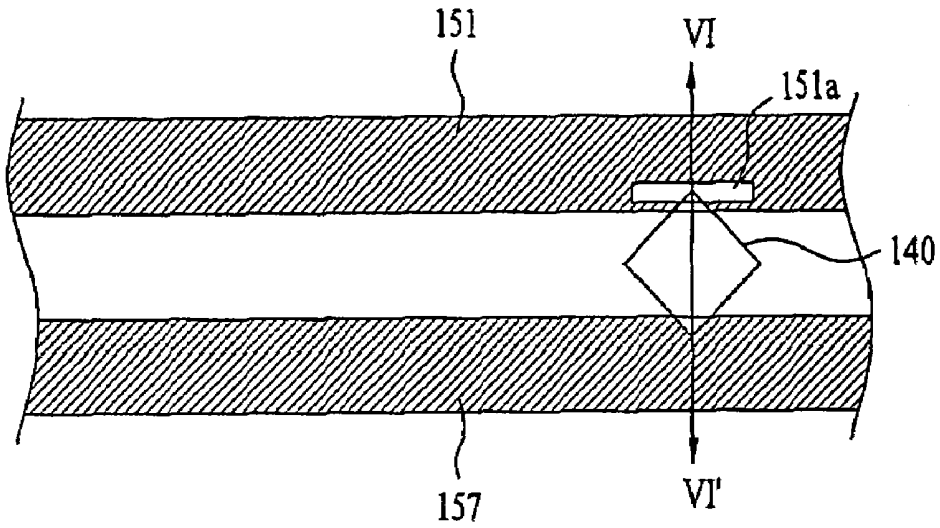

FIG. 15

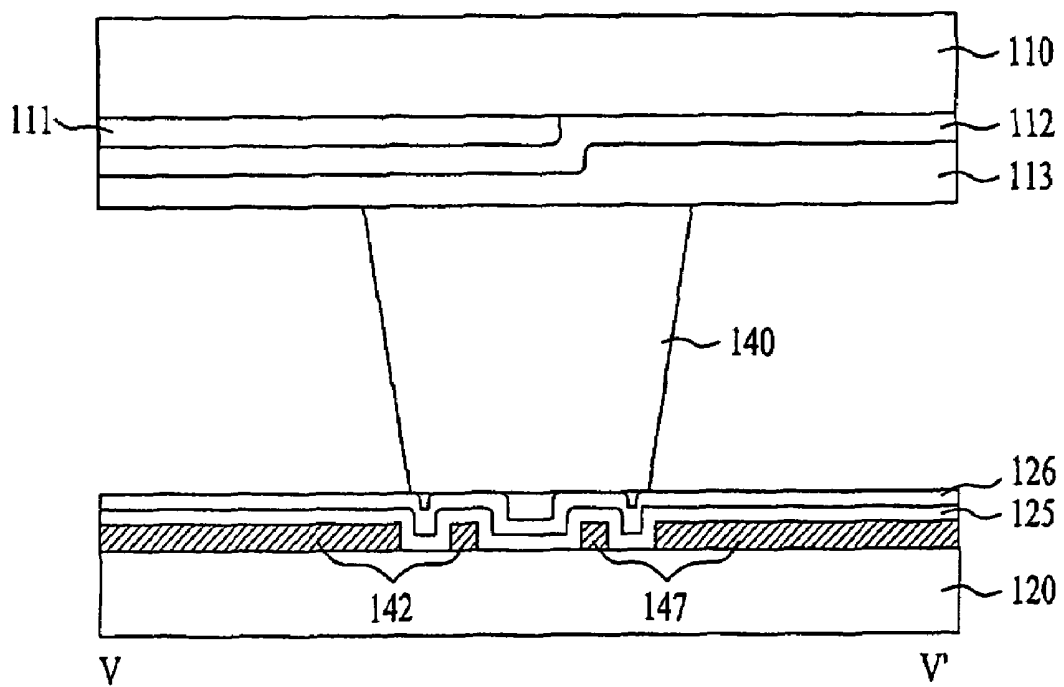

FIG. 16

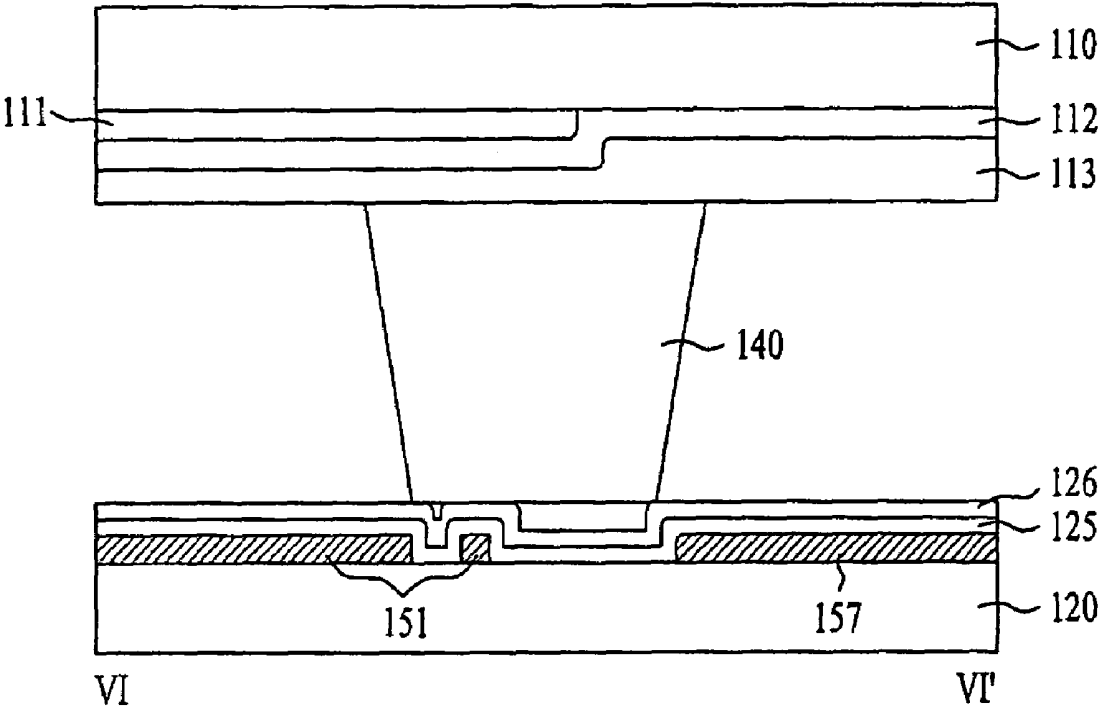
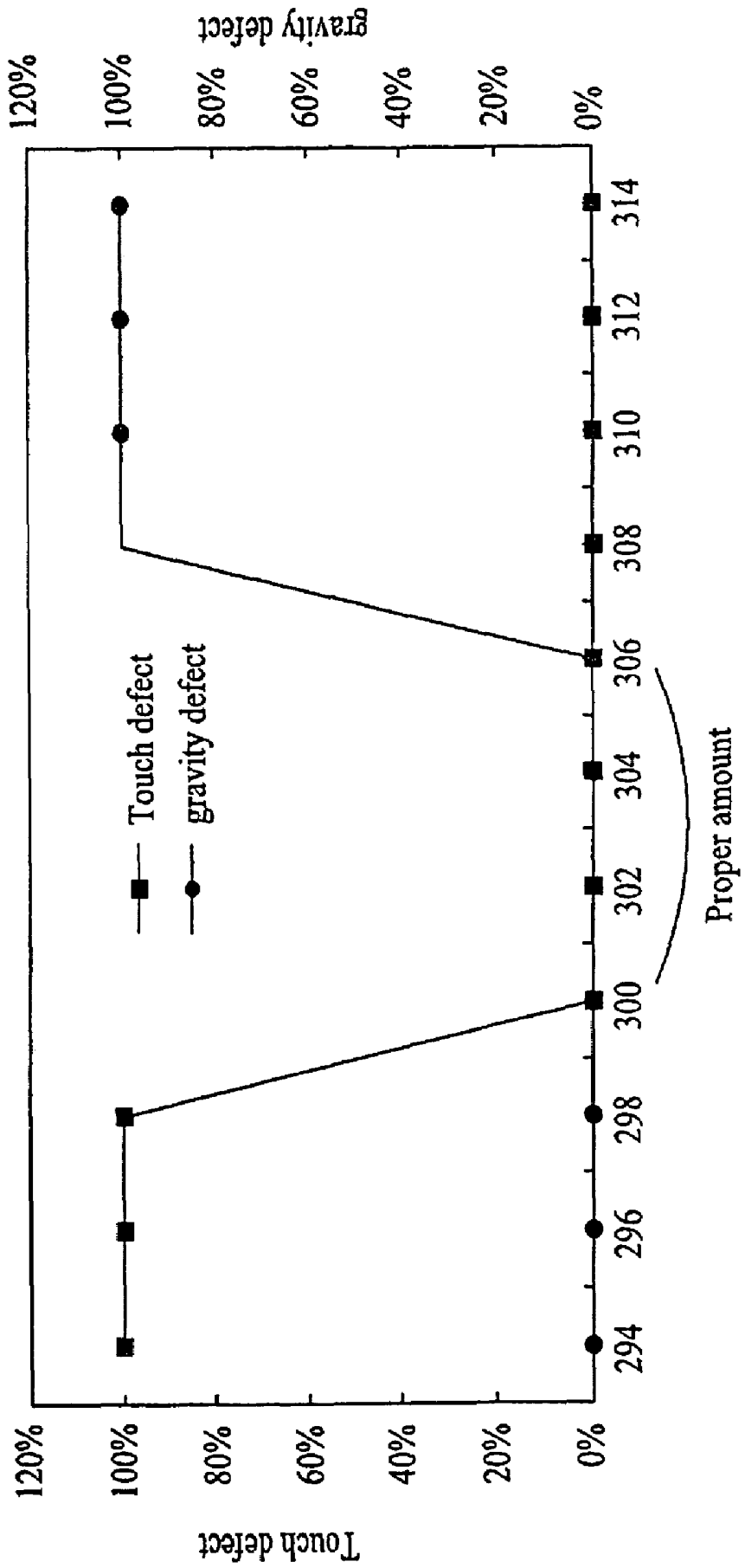

FIG. 17



**LIQUID CRYSTAL DISPLAY DEVICE
HAVING SPACERS OVERLAPPED WITH
SLITS IN THE COMMON LINE AND GATE
LINE**

This application claims the benefit of the Korean Patent Application No. 10-2004-116284, filed on Dec. 30, 2004, which is hereby incorporated by reference for all purposes as if fully set forth herein.

BACKGROUND OF THE INVENTION

1. Field of the Invention

The present invention relates to a liquid crystal display (LCD) device, and more particularly, to an LCD device in which column spacers for a cell gap are arranged between gate and common lines to reduce a contact area between the column spacers and an opposing substrate, and a stable cell gap is maintained over the whole panel by reducing variation of a thickness per area of a thin film transistor (TFT) substrate corresponding to the column spacers.

2. Discussion of the Related Art

A related art LCD device will be described with reference to the accompanying drawings.

FIG. 1 is an exploded perspective view illustrating a related art LCD device.

As shown in FIG. 1, the related art LCD device includes a first substrate **1**, a second substrate **2**, and a liquid crystal layer **3** formed between the first and second substrates **1** and **2** by injection.

In more detail, the first substrate **1** includes a plurality of gate lines **4** arranged along a first direction at fixed intervals, and a plurality of data lines **5** arranged along a second direction perpendicular to the first direction at fixed intervals. A plurality of pixel electrodes **6** are arranged in a matrix-type configuration within pixel regions **P** defined by crossing the gate and data lines **4** and **5**. The first substrate **1** also includes a plurality of TFTs **T** formed at respective areas where the gate lines **4** cross the data lines **5** to transmit data signals from the data lines to the respective pixel electrodes according to gate pulse signals supplied to the gate lines.

Also, the second substrate **2** includes a black matrix layer **7** that blocks light from portions of the first substrate **1** except the pixel regions **P**, an R/G/B color filter layer **8** for displaying various colors, and a common electrode **9** for producing the image on the color filter layer **8**.

In the aforementioned LCD device, the liquid crystal layer **3** is aligned by an electric field generated between the pixel electrode **6** and the common electrode **9**. Light irradiated through the liquid crystal layer **3** may be controlled by the alignment direction of the liquid crystal layer **3**, thereby displaying the image.

This kind of LCD device is referred to as a twisted nematic (TN) mode LCD device, which has disadvantageous characteristics such as a narrow viewing angle. In order to overcome the narrow viewing angle, an In-Plane switching (IPS) mode LCD device has been actively developed.

In the IPS mode LCD device, a pixel electrode and a common electrode are formed in a pixel region parallel to each other at a fixed interval therebetween, an electric field parallel to the substrates develops between the pixel electrode and the common electrode, thereby aligning the liquid crystal layer according to the electric field parallel to the substrates.

Meanwhile, a method of manufacturing a related art LCD device is classified into a liquid crystal injection method and

a liquid crystal dispensing method depending upon a method of forming a liquid crystal layer between a first substrate and a second substrate.

First, the method of manufacturing the LCD device according to the liquid crystal injection method will be described as follows.

An LCD panel and a container having liquid crystal material therein are provided in a chamber, and the chamber is evacuated. Moisture and air bubbles in the liquid crystal material and the container are simultaneously removed, and an inside space of the LCD panel is maintained in a vacuum state.

Then, an injection inlet of the LCD panel is dipped into the container having the liquid crystal material in the vacuum state, and the vacuum state inside the chamber is brought to atmospheric pressure. Thus, the liquid crystal material is injected into the LCD panel through the injection inlet by a pressure difference between the inside of the LCD panel and the chamber.

However, the method of manufacturing the LCD device by the liquid crystal injection method has the following disadvantages.

First, after cutting a large sized glass substrate into the respective LCD panel regions, the injection inlet is dipped into the container having the liquid crystal material while maintaining the vacuum state between the two substrates. The process of injecting liquid crystal material between the two substrates is slow thereby lowering yield.

Also in the case of forming a large sized LCD device, it is difficult to completely inject the liquid crystal material into the inside of the LCD panel, thereby causing failure due to incomplete injection of the liquid crystal material.

Furthermore, the process of the liquid crystal material is slow and a large space is required for the liquid crystal injection device.

In order to overcome the problems with the liquid crystal injection method, the liquid crystal dispensing method has been developed. In the dispensing method, two substrates are bonded to each other after dispensing liquid crystal material on any one of the two substrates.

In this method, it is impossible to use ball spacers for maintaining a cell gap between the two substrates since the ball spacers move in the spreading direction of liquid crystal material.

Thus, instead of the ball spacers, patterned spacers or column spacers are fixed to any one of the two substrates to maintain the cell gap between the two substrates.

FIG. 2A is a structural sectional view illustrating a color filter substrate provided with column spacers, and FIG. 2B is a structural sectional view illustrating the state when a TFT substrate is bonded to the color filter substrate.

As shown in FIG. 2A, the column spacers **20** are formed on a black matrix layer (not shown) of the color filter substrate **2**. In this case, each of the column spacers **20** has a height "h".

As shown in FIG. 2B, if the color filter substrate **2** provided with the column spacers **20** is arranged to oppose the TFT substrate **1** and is bonded to the TFT substrate **1**, the column spacers **20** are contracted at a height "h" representing a height of a cell gap due to pressure generated when bonding the substrates together.

As shown in FIG. 2A and FIG. 2B, the column spacers **20** within a panel **10** bonding the substrates together are pressed at a thickness h-h' according to the pressure during bonding and contracted at the height "h" of the cell gap.

As described above, the LCD device including the column spacers has a relatively large contact area with an opposing substrate (TFT substrate) unlike the ball spacers, thereby

causing a great frictional force due to the increase in the contact area to the substrate. Accordingly, in a case where the screen of the LCD device having the column spacers is rubbed, spots may be generated on the screen for a long time.

FIG. 3A and FIG. 3B are a plan view and a cross-sectional view illustrating the spots generated on the screen by touching the LCD panel.

As shown in FIG. 3A, if the LCD panel 10 is continuously touched with a finger or pen along a predetermined direction, the second substrate 1 of the LCD panel 10 is shifted at a predetermined interval along the touched direction as shown in FIG. 3B. At this time, the second substrate 1 is not restored to the original state for a long time. In this case, liquid crystal molecules 3 touched with a finger or pen are dispersed and the liquid crystal molecules 3 are gathered in the region around the touch portion. For this reason, a cell gap h1 corresponding to the region where the liquid crystal molecules are gathered is higher than a cell gap h2 of the remaining portions, thereby generating a touch defect that represents spots around the touch portion due to surplus and shortage of the liquid crystal molecules.

The touch defect is generated in the LCD device provided with the column spacers because the column spacers are fixed to one substrate and are in contact with another opposing substrate in a surface type to form a relatively large contact area unlike the globular ball spacers.

Consequently, the aforementioned related art LCD device has the following disadvantages.

First, in the related art LCD device provided with the column spacers, when the LCD panel is touched while being pressed in a predetermined direction, the substrates shifted in opposing directions are not restored to the original state or it takes a long time even if they are restored to the original state. For this reason, light leakage occurs in a portion where the liquid crystal molecules are pushed from the touch portion during a restoring time. It is noted that such a touch defect is caused by the frictional force generated by a large contact area between the column spacers and their opposing substrate.

Second, the ball spacers are dispersed for injection of the liquid crystal and have a globular form. When a predetermined area of the panel is pressed, the ball spacers corresponding to the predetermined area of the panel are slid and have tolerance to the pressed pressure. However, since the column spacers are selectively in portions except for the pixel region, the column spacers may easily be deformed when the portion having no column spacers is pressed. A structure below the column spacers may be broken.

Third, a height difference occurs in the column spacers due to a gap between the column spacers. In this case, the contact area and the contact pressure between the column spacers and the opposing substrate are varied, thereby generating a defect of a cell gap over the whole panel.

Such a problem seriously occurs in large sized LCD panel based on the liquid crystal dispensing method in forming the liquid crystal layer of the LCD panel. This is caused by difficulty in selecting a proper amount of the liquid crystal dispensed on the substrate unlike the liquid crystal dispensing method in which the liquid crystal is injected into the substrate by the pressure difference between the inside of the LCD panel and the outside thereof.

SUMMARY OF THE INVENTION

Accordingly, the present invention is directed to an LCD device that substantially obviates one or more problems due to limitations and disadvantages of the related art.

An advantage of the present invention is to provide an LCD device in which column spacers for a cell gap are arranged between gate and data lines to reduce a contact area between the column spacers and an opposing substrate and a stable cell gap is maintained over the whole panel by reducing variation of a thickness per area of a thin film transistor (TFT) substrate corresponding to the column spacers.

Additional advantages, and features of the invention will be set forth in part in the description which follows and in part will become apparent to those having ordinary skill in the art upon examination of the following or may be learned from practice of the invention. The advantages of the invention may be realized and attained by the structure particularly pointed out in the written description and claims hereof as well as the appended drawings.

To achieve these and other advantages and in accordance with the purpose of the invention, as embodied and broadly described herein, an LCD device according to the present invention includes first and second substrates facing each other; gate and data lines formed on the first substrate to cross each other, thereby defining pixel regions; a thin film transistor (TFT) formed in each portion where the gate lines cross the data lines; common lines formed adjacent to the gate lines; at least one common electrode extended from the common line and at least one pixel electrode connected to a drain electrode of the thin film transistor in each of the pixel regions; a plurality of first column spacers, each formed on the second substrate corresponding to a portion between the gate line and the common line; and a liquid crystal layer filled between the first and second substrates.

The first column spacer corresponds to a recessed portion between the gate and common lines.

The first column spacer is overlapped with the gate line. The LCD device further includes a gate slit formed in the gate line overlapped with the first column spacer.

The first column spacer is overlapped with the common line. The LCD device further includes a common slit formed in the common line overlapped with the first column spacer.

The first column spacer is overlapped with both the gate line and the common line. The LCD device further includes at least one slit in the common and gate lines overlapped with the first column spacer.

The LCD device further includes a second column spacer formed on the second substrate to correspond to a predetermined portion of the gate line. The second column spacer is not in contact with the first substrate. The second column spacer is spaced apart from the uppermost surface of the first substrate at an interval of 0.2 μm to 0.6 μm when the first substrate is bonded to the second substrate.

The LCD device further includes a black matrix layer formed on the second substrate to shield portions except for pixel regions and the TFT, and an R/G/B color filter layer formed to correspond to the pixel regions. The LCD device further includes an overcoat layer formed on an entire surface of the second substrate including the black matrix layer and the color filter layer.

The gate and common lines are formed on one layer.

The LCD device further includes a gate insulating layer interposed between the layer of the gate and common lines and a layer of the data line.

The LCD device further includes a passivation film interposed between the layer of the data line and a layer of the pixel electrode.

It is to be understood that both the foregoing general description and the following detailed description of the

present invention are exemplary and explanatory and are intended to provide further explanation of the invention as claimed.

BRIEF DESCRIPTION OF THE DRAWINGS

The accompanying drawings, which are included to provide a further understanding of the invention and are incorporated in and constitute a part of this application, illustrate embodiment(s) of the invention and together with the description serve to explain the principle of the invention. In the drawings:

FIG. 1 is an exploded perspective view illustrating a related art LCD device;

FIG. 2A is a structural sectional view illustrating a color filter substrate provided with column spacers;

FIG. 2B is a structural sectional view illustrating the state that a TFT substrate is bonded to the color filter substrate;

FIG. 3A and FIG. 3B are a plan view and a cross-sectional view illustrating spots generated on the screen by touching an LCD panel;

FIG. 4 is a sectional view illustrating a structure of an extension according to the present invention;

FIG. 5 is a plan view illustrating one pixel of an LCD device having an extension according to the present invention;

FIG. 6 is a structural sectional view taken along line I-I' of FIG. 5;

FIG. 7A and FIG. 7B are sectional views illustrating extensions and column spacers corresponding to the extensions according to the present invention;

FIG. 8 is a plan view illustrating a structure of column spacers corresponding to a TFT according to the present invention;

FIG. 9 is a structural sectional view taken along line II-II' of FIG. 8;

FIG. 10 is a plan view illustrating an LCD device according to the first embodiment of the present invention;

FIG. 11A is a structural sectional view taken along line III-III' of FIG. 10;

FIG. 11B is a structural sectional view taken along line IV-IV' of FIG. 10;

FIG. 12 is a plan view illustrating a first column spacer of an LCD device according to the second embodiment of the present invention;

FIG. 13 is a plan view illustrating a first column spacer of an LCD device according to the third embodiment of the present invention;

FIG. 14 is a plan view illustrating a first column spacer of an LCD device according to the fourth embodiment of the present invention;

FIG. 15 is a structural sectional view taken along line V-V' of FIG. 13;

FIG. 16 is a structural sectional view taken along line VI-VI' of FIG. 14; and

FIG. 17 is a graph illustrating a liquid crystal dispensing margin in a structure of an LCD device according to the present invention.

DETAILED DESCRIPTION OF THE ILLUSTRATED EMBODIMENTS

Reference will now be made in detail to embodiments of the present invention, examples of which are illustrated in the accompanying drawings. Wherever possible, the same reference numbers will be used throughout the drawings to refer to the same or like parts.

If an LCD panel provided with column spacers is touched with a finger or pen along a predetermined direction, a substrate of the LCD panel is shifted at a predetermined interval along the touched direction. Since it takes a long time to restore the substrate to the original state, a touch defect that represents spots around the touch portion occurs for a time to restore the substrate to the original state. The touch defect is caused by a frictional force generated due to a large contact area between the column spacers and their opposing substrate. Therefore, to remove the touch defect, efforts to reduce the contact area have been performed. One of the efforts is an LCD device having an extension.

FIG. 4 is a sectional view illustrating a structure of an extension according to the present invention.

In FIG. 4, a column spacer 70 is formed on a first substrate 60 and an extension 75 is formed on a second substrate 80, so that a contact area between the column spacer 70 and the second substrate 80 can be reduced.

The extension 75 serves to reduce a frictional force between the column spacer and its opposing substrate by reducing a large contact area between the column spacer and the opposing substrate considering that a touch defect occurs due to the contact area, thereby preventing the touch defect from occurring.

FIG. 5 is a plan view illustrating one pixel of an LCD device having an extension according to the present invention, and FIG. 6 is a structural sectional view taken along line I-I' of FIG. 5.

As shown in FIG. 5 and FIG. 6, the LCD device having an extension includes first and second substrates 60 and 80 bonded to each other at a certain space, a liquid crystal layer 90 injected between the first substrate 60 and the second substrate 80, a column spacer 70 formed on the first substrate 60, and an extension 75 formed on the second substrate 80 to correspond to the column spacer 70.

In more detail, the first substrate 60 includes a black matrix layer 61 shielding light from portions (regions for gate and data lines and TFT) except for a pixel region, an R/G/B color filter layer 62 formed to correspond to the pixel region, thereby displaying colors, and an overcoat layer 63 formed on an entire surface of the black matrix layer 61 and the color filter layer 62.

The second substrate 80 includes a plurality of gate lines 81 vertically crossing a plurality of data lines 82 to define pixel regions, pixel and common electrodes 83 and 87a alternately formed in each pixel region where the gate lines 81 cross the data lines 82, and a plurality of TFTs formed at respective areas where the gate lines 81 cross the data lines 82. The common electrode 87a is forked from common lines 87 parallel to the gate lines 81. The common and pixel electrodes 87a and 83 are formed substantially parallel to each other in a zigzag pattern.

The process of fabricating the above elements on the second substrate will be described as follows.

A metal material such as Mo, Al and Cr is deposited on the second substrate 80 by sputtering and then patterned using a mask (not shown) to form a plurality of gate lines 81 and a gate electrode 81a extended from the gate lines. The common lines 87 are formed in parallel to the gate lines 81, and the common electrodes 87a forked from the common lines 87 are formed within the pixel region. The common electrodes 87a are formed in a zigzag pattern.

Subsequently, an insulating material such as SiNx is deposited on the second substrate 80 including the gate lines 81 to form a gate insulating layer 85.

A semiconductor layer 84 is formed on the gate insulating layer 85 on the gate electrode 81a. The semiconductor layer

84 is formed in such a manner that an amorphous silicon layer and an n+ layer heavily doped with P are sequentially deposited on the gate insulating layer **85** and then patterned using a mask (not shown). The semiconductor layer **84** selectively remains at a predetermined width in a predetermined portion on the gate line **81** to form a semiconductor layer pattern **84a**.

Afterwards, a metal material such as Mo, Al and Cr is deposited on the entire surface by sputtering and then patterned using a mask (not shown) to form data lines **82** and source and drain electrode **82a** and **82b** at both sides of the gate electrode **81a**. The source electrode **82a** is extended from the data line **82**. The n+ layer below the source and drain electrodes **82a** and **82b** is overetched. Thus, the n+ layer is removed from the gate electrode **81a**, and the exposed portion is defined as a channel region of the TFT. The semiconductor layer **84** is comprised of the amorphous silicon layer and the n+ layer. A source and drain metal layer **82d** is formed on a predetermined portion of the semiconductor layer pattern **84a** at a predetermined width (preferably, smaller than the semiconductor layer pattern **84a**) along with the data line **82**. The extension **75** is formed by depositing the source and drain metal layer **82d** and the semiconductor layer pattern **84a**.

Next, a passivation film **86** of SiNx is deposited on the entire surface of the gate insulating layer **85** including the semiconductor layer pattern **84a**, the data line **82**, the source electrode **82a** and the drain electrode **82b** by a chemical vapor deposition (CVD) method. An inorganic material such as SiNx is mainly used as a material of the passivation film **86**. An organic material having low dielectric ratio, such as Benzocyclobutene (BCB), Spin On Glass (SOG), and acryl, may be used as a material of the passivation film **86** to improve an aperture ratio of a liquid crystal cell.

Subsequently, the passivation film **86** on the drain electrode **82b** is partially etched using a mask (not shown) to form a contact hole that partially exposes the drain electrode **82b**.

A transparent electrode material is deposited on the passivation film **86** by sputtering to sufficiently bury the contact hole. The transparent electrode material is then patterned using a mask (not shown) to form pixel electrodes **83** in the pixel regions. The pixel electrodes **83** alternate with the common electrodes **87a**. At this time, the pixel electrodes **83** are electrically connected to the drain electrode **82b** through the contact hole.

The column spacer **70** is formed on an uppermost portion (the overcoat layer **63** in the drawing) of the first substrate to correspond to the extension **75**. In this case, since the column spacer **70** is in contact with an upper area of the extension **75**, a frictional force is reduced when the LCD panel is touched, thereby minimizing the touch defect.

In the aforementioned LCD device having an extension, the gate line **81**, the gate insulating layer **85**, the semiconductor layer pattern **84a**, the source and drain metal layer **82d**, and the passivation film **86** are formed around the extension. A gap in the range of $\pm 10\%$ of a deposition thickness is formed during deposition. Therefore, if the semiconductor layer pattern **84a** and the source and drain metal layer **82d** are respectively formed at a thickness of 2000 Å, the extension **75** needs a thickness of about 4000 Å. However, the extension **75** may be formed over the whole LCD panel at a thickness of 3600 Å to 4400 Å due to the gap (thickness varying factor). In this way, when the extension **75** is formed, a separate pattern is further formed on the gate line **81** and two layers are further deposited and etched. Thus, unlike other portions on the gate line **81**, a gap of about 800 Å additionally occurs in a portion where the extension **75** is formed. Since the passivation film,

the gate insulating layer and the gate line are further formed on and below the extension **75**, the total gap may be 2000 Å (=400 Å×3+800 Å) assuming that the other layers are formed at a thickness of 2000 Å.

FIG. 7A and FIG. 7B are sectional views illustrating the extension and the column spacer corresponding to the extension according to the present invention.

FIG. 7A illustrates the extension **75a** having no gap and the column spacer corresponding to the extension **75a**. In this case, the column spacer **70** is normally in contact with the extension **75a** without pressure.

As shown in FIG. 7B, if the extension **75b** is formed to have a large gap, especially at a value greater than a desired value, the column spacer **70** is pressed by the extension **75b**, thereby causing deformation of the column spacer in which a portion of the column spacer corresponding to the extension **75b** is additionally pressed by a thickness 'a'.

Although not shown, if the extension **75b** is smaller than a desired size, the extension is not in contact with the column spacer. In this case, it is difficult to prevent the touch defect from occurring.

As described above, in the extension structure using the semiconductor layer and the source and drain metal layer, the thickness varying factor of the semiconductor layer and the source and drain metal layer serves as a factor that varies a volume of the panel. Therefore, in a large sized LCD device of 30 inch or greater, the thickness varying factor serves to reduce a liquid crystal dispensing margin (in the range of a liquid crystal corresponding to a level having neither touch defect nor gravity defect).

In the aforementioned LCD device, the extension is formed on the gate line to remove the touch defect. However, it is possible to form the column spacer to correspond to the TFT without forming the extension of the gate line.

Hereinafter, in an LCD device having a 'U' shaped TFT, a structure of the column spacer corresponding to the 'U' shaped TFT will be described. In this structure, the touch defect can be removed by reducing the contact area between the column spacer and its opposing substrate.

FIG. 8 is a plan view illustrating a structure of the column spacer corresponding to the TFT according to the present invention, and FIG. 9 is a structural sectional view taken along line II-II' of FIG. 8.

As shown in FIG. 8 and FIG. 9, the LCD device having the 'U' shaped TFT includes first and second substrates **110** and **120** and a liquid crystal layer **90** filled between the two substrates.

In more detail, the first substrate **110** includes a black matrix layer **111** shielding light of portions (regions for gate and data lines and TFT) except for pixel regions, an R/G/B color filter layer **112** formed to correspond to the pixel regions, thereby displaying colors, and an overcoat layer **113** formed on an entire surface of the black matrix layer **111** and the color filter layer **112**.

The second substrate **120** includes a plurality of gate lines **121** vertically crossing a plurality of data lines **122** to define pixel regions, pixel and common electrodes **123** and **127a** alternately formed in each pixel region where the gate lines **121** cross the data lines **122**, and a plurality of TFTs formed at respective areas where the gate lines **121** cross the data lines **122**. The common electrode **127a** is forked from common lines **127** substantially parallel to the gate lines **121**. The common and pixel electrodes **127a** and **123** are formed parallel to each other in a zigzag pattern.

The TFT includes a gate electrode **121a** formed in a single body with the gate line **121**, a 'U' shaped source electrode **122a** extended from the data line **122**, a drain electrode **122b**

entering the 'U' shaped source electrode **122a** and connected to the pixel electrode **123**, and a semiconductor layer **124** covering an upper portion of the gate electrode **121a** and formed in contact with lower portions of the source electrode **122a** and the drain electrode **122b**.

Further, a gate insulating layer **125** is interposed between the gate line **121** and the common line **127** and between the gate line **121** and the data line **122**. A passivation film **126** is interposed between the data line **122** and the pixel electrode **123**.

A column spacer **101** is formed on the overcoat layer **113** of the first substrate **110** to correspond to a channel region of the TFT.

In this case, the column spacer **101** is formed on the semiconductor layer **124** of the TFT to cross the 'U' shaped source electrode **122a**. Since the upper portion of the drain electrode **122b** is extended to the portion where the column spacer **101** is formed, the passivation film **126** on the drain electrode **122b** is in contact with the column spacer **101**. Therefore, the contact area between the column spacer **101** and its opposing substrate can be reduced even in case where the 'U' shaped TFT is formed, in the same manner as the extension structure.

However, in the structure in which the column spacer is formed on the TFT, the gate electrode **121a**, the gate insulating layer **125**, the semiconductor layer **124**, the source and drain metal electrodes **122a** and **122b**, and the passivation film **126** are deposited on the substrate where the column spacer is actually formed in the same manner as the extension structure. For example, if each layer is formed at a thickness of about 2000 Å, a gap of a portion corresponding to the column spacer is $400 \text{ Å} \times 5 = 2000 \text{ Å}$ considering that a gap of $\pm 10\%$ is generated when each layer is formed. Deformation of the column spacer is varied in the portion corresponding to the column spacer depending on the serious degree of the gap, thereby causing the great difference between cell gaps in respective portions.

Therefore, an LCD device having a step difference in the substrate corresponding to the column spacer and a minimized gap in the portion corresponding to the column spacer will now be described in detail.

FIG. 10 is a plan view illustrating an LCD device according to the first embodiment of the present invention, FIG. 11A is a structural sectional view taken along line III-III' of FIG. 10, and FIG. 11B is a structural sectional view taken along line IV-IV' of FIG. 10.

As shown in FIG. 10, FIG. 11A and FIG. 11B, the LCD device according to the first embodiment of the present invention includes first and second substrates **110** and **120** facing each other and bonded to each other, and a liquid crystal layer (not shown) filled between the two substrates.

In more detail, the first substrate **110** includes a black matrix layer **111** shielding light from portions (regions for gate and data lines and TFT) except for pixel regions, an R/G/B color filter layer **112** formed to correspond to the pixel regions, thereby displaying colors, and an overcoat layer **113** formed on an entire surface of the black matrix layer **111** and the color filter layer **112**.

The second substrate **120** includes a plurality of gate lines **131** vertically crossing a plurality of data lines **122** to define pixel regions, pixel and common electrodes **123** and **127a** formed in each pixel region substantially parallel with each other, and a plurality of 'U' shaped TFTs formed at respective areas where the gate lines **131** cross the data lines **122**. The common electrode **127a** is forked from common lines **137** parallel to the gate lines **131**. The common and pixel electrodes **127a** and **123** are formed substantially parallel to each other in a zigzag pattern.

Each of the TFTs includes a gate electrode **121a** formed in a single body with the gate line **131**, a 'U' shaped source electrode **122a** extended from the data line **122**, a drain electrode **122b** entering the 'U' shaped source electrode **122a** and connected to the pixel electrode **123**, and a semiconductor layer (not shown) covering an upper portion of the gate electrode **121a** and formed in contact with lower portions of the source electrode **122a** and the drain electrode **122b**.

Further, a gate insulating layer **125** is interposed between the gate line **131** and the common line **137** and between the gate line **131** and the data line **122**. A passivation film **126** is interposed between the data line **122** and the pixel electrode **123**.

In the LCD device according to the first embodiment of the present invention, a first column spacer **140** is formed on the overcoat layer **113** of the first substrate **110** to correspond to a portion between the gate line **131** and the common line **137**. In other words, the common line **137** and the gate line corresponding to the portion where the first column spacer **140** is formed have a width smaller than those of other portions, so that the first column spacer is not overlapped with the common line **137** and the gate line **131**.

In this case, as shown in FIG. 11A, the first column spacer **140** is in contact with the passivation film **126** formed with a step difference between the gate line **131** and the common line **137**. The first column spacer **140** forms a cell gap between the first and second substrates **110** and **120** and has a small contact area with its opposing substrate, i.e., the passivation film **126** formed on the uppermost of the second substrate **120**. In other words, a portion where the metal line (gate line or common line) is not formed serves as a recessed portion between the gate line **131** and the common line **137**. Therefore, the gate insulating layer **125** and the passivation film **126** formed on the gate line **131** and the common line **137** are formed with a step difference due to the recessed portion corresponding to the portion between the gate line **131** and the common line **136**. The first column spacer **140** is formed to correspond to the recessed portion and around the recessed portion. The upper portion of the first column spacer **140** corresponding to the recessed portion is not contacted to the passivation film **126**. Therefore, the small contact area is formed between the first column spacer **140** and the passivation film **126**.

A size of the contact area between the first column spacer **140** and the passivation film **126** is varied depending on the interval between the gate line **131** and the common line **137** or the retracted range of the gate line **131** or the common line **137** at the portion where the column spacer **140** is formed. At this time, the interval between the gate line **131** and the common line **137** is in the range of about 10 μm to 16 μm based on resolution of an exposing unit. The first column spacer **140** is formed between the gate line **131** and the common line **137** over the interval of about 10 μm to 16 μm . The interval between the gate line **131** and the common line **137** may be narrowed in the range of about 8 μm if resolution of the exposing unit becomes great.

Furthermore, as shown in FIG. 11B, a second column spacer **141** is formed on the overcoat layer **113** of the first substrate **110** to correspond to a predetermined portion of the gate line **131**. The second column spacer **141** has a height smaller than that of the first column spacer **140** by about 0.2 μm to 0.6 μm . The second column spacer is spaced apart from the passivation film **126** corresponding to the uppermost of the opposing substrate **120** at a predetermined interval to prevent the touch defect of the column space from occurring.

In this case, the first column spacer **140** is formed per three pixels (subpixel) at a sectional size of 14 $\mu\text{m} \times 14 \mu\text{m}$ (prefer-

ably, 10 μm to 30 μm ×10 μm to 30 μm) around the first substrate **110**. Also, the second column spacer **141** is formed per three pixels at a sectional size of 14 μm ×14 μm (preferably, 10 μm to 30 μm ×10 μm to 30 μm) around the first substrate **110**.

The first and second column spacers **140** and **141** are formed on the uppermost surface of the first substrate **110**, i.e., the overcoat layer **113**. The lower surfaces of the column spacers may be formed in various polygonal shapes, for example, polygonal columns having a certain height. The lower surfaces of the column spacers may have a cylinder shape. Also, they may have a square column shape as shown. The sizes of the first and second column spacers **140** and **141** may be varied depending on the size of the LCD panel. The sizes of the first and second column spacers **140** and **141** may be varied depending on line widths of the gate line **131** and the common line **137** and a line width of a space between the gate line **131** and the common line **137**. The retracted range of the gate line **131** and the common line **137** corresponding to the first column spacer **140** depends on the size of the first column spacer **140**. In this case, the retracted portion of the gate line **131** or the common line **137** has the line width in the range that resistance of the gate line **131** or the common line **137** does not become great. In other words, even if the gate line **131** or the common line **137** is partially retracted, the line width should be obtained in the range that response speed is not deteriorated when the LCD device is driven.

The first and second column spacers **140** and **141** are formed under the same process condition. The first and second column spacers **140** and **141** have different exposing amounts per portion to form different heights from each other. For example, if the first and second column spacers **140** and **141** are formed of a negative photo-hardening resin, a first mask is arranged on the first substrate **110** to perform an exposure process, wherein the first mask includes a transparent portion defined to correspond to the first column spacer **140** and a semitransparent portion defined to correspond to the second column spacer **141**. If the first and second column spacers **140** and **141** are formed of a positive photo-hardening resin, a second mask opposite to the first mask is used.

The first and second column spacers **140** and **141** are formed to correspond to the step difference formed on the second substrate **120**. The step difference is formed between the gate line **131** and the common line **137**. Therefore, the gate line **131** or the common line **137**, the gate insulating layer **125**, and the passivation film **126** are formed on the second substrate **120** corresponding to the first and second column spacers **140** and **141**. In this case, since two layers are not formed in comparison with the structure in which the column spacer is formed to correspond to the TFT, imbalance of the step difference generated in each portion can be reduced.

In the LCD device of the present invention, for example, if the semiconductor layer (not shown) and the data line **122** are respectively formed at a thickness of about 2000 Å, a gap of each portion is in the range of $\pm 10\%$ of a deposition thickness. In this case, it is possible to reduce a gap corresponding to a thickness of $2 \times 400 \text{ \AA} = 800 \text{ \AA}$ in comparison with the deposition structure of the semiconductor layer and the data line in which the column spacer is formed to correspond to the extension or the TFT.

Meanwhile, although the LCD device shown in FIG. 10 has a 'U' shape, the LCD device of the present invention may have various shapes without being limited to the 'U'-shape.

Hereinafter, a method for fabricating the LCD device having the TFT will be described.

A metal material such as Mo, Al and Cr is deposited on the second substrate **120** by sputtering and then patterned using a

mask (not shown) to form the plurality of gate lines **131** and the gate electrodes **121a** extended from the gate lines **131**. The common lines **137** are formed in parallel with the gate lines **131**. The common electrodes **127a** forked from the common lines **137** are formed in the pixel regions in a zigzag arrangement. A predetermined portion where the gate lines **131** face the common lines **137** may be retracted (at a thinner line width).

Subsequently, an insulating material of SiNx is deposited on the second substrate **120** including the gate lines **131** to form the gate insulating layer **125**.

The semiconductor layer **124** is formed on the gate insulating layer **125** to cover the gate electrode **121a**. The semiconductor layer **124** is formed in such a manner that an amorphous silicon layer and an n+ layer heavily doped with P are sequentially deposited on the gate insulating layer **125** and then patterned using a mask (not shown).

Afterwards, a metal material such as Mo, Al and Cr is deposited on the entire surface by sputtering and then patterned using a mask (not shown) to form the data lines **122** and the source and drain electrodes **122a** and **122b** at both sides of the gate electrode **121a**. The source electrode **122a** is extended from the data line **122**. At this time, the n+ layer below the source and drain electrodes **122a** and **122b** is overetched. Thus, the n+ layer is removed from the gate electrode **121a**. In this case, the amorphous silicon layer is exposed from the gate electrode **121a**, and the exposed portion is defined as a channel region of the TFT. The semiconductor layer **124** is comprised of the amorphous silicon layer and the n+ layer.

Next, the passivation film **126** of SiNx is deposited on the gate insulating layer **125** including the semiconductor layer **124**, the data line **122**, the source electrode **122a** and the drain electrode **122b** by a chemical vapor deposition (CVD) method. An inorganic material such as SiNx is mainly used as a material of the passivation film **126**. Recently, an organic material having low dielectric ratio, such as BenzoCycloButene (BCB), Spin On Glass (SOG), and acryl, is used as a material of the passivation film **126** to improve an aperture ratio of a liquid crystal cell.

Subsequently, the passivation film **126** on the drain electrode **122b** is partially etched using a mask (not shown) to form a contact hole that partially exposes the drain electrode **122b**.

A transparent electrode material is deposited on the passivation film **126** by sputtering to sufficiently bury the contact hole. The transparent electrode material is then patterned using a mask (not shown) to form the pixel electrodes **123** in the pixel regions. The pixel electrodes **123** alternate with the common electrodes **127a**. At this time, the pixel electrodes **123** are electrically connected with the drain electrode **122b** through the contact hole.

The black matrix layer **111** is formed on the first substrate **110** to correspond to portions (gate lines, data lines and TFT) where the pixel regions are not formed. The color filter layer **112** is formed to correspond to the pixel regions, and the overcoat layer **113** is formed on the entire surface of the first substrate **110** including the black matrix layer **111** and the color filter layer **112**.

A photo-hardening resin is deposited on the entire surface of the overcoat layer **113** and then selectively removed to form the first column spacer **140** of the first height corresponding to the portion between the gate line **131** and the common line **137** of the second substrate **120** and the second column spacer **141** of the second height corresponding to the predetermined portion of the gate line **131**.

In this case, the first height is higher than the second height by about 0.21 μm to 0.6 μm . This height difference may be generated by varying the exposing amount using each portion of a first mask, which defines the first and second column spacers **140** and **141**, as a transparent portion and a semitransparent portion. In this case, the photo-hardening resin is a negative photo-hardening resin. If the first and second common spacers **140** and **141** are of a positive photo-hardening resin, a second mask opposite to the first mask is used.

In case where the first column spacer **140** is formed as above, the contact area between the first column spacer **140** and the second substrate **120** can be reduced to prevent the touch defect from occurring and a cell gap between the first and second substrates **110** and **120** can be maintained.

Also, in case where the second column spacer **141** is formed as above, a gap between the second substrate and the column spacer is obtained so as to obtain a margin, thereby failing to cause deformation of the column spacer when the column spacer is pressurized during bonding of the column spacer to the second substrate **120**.

Meanwhile, an alignment layer may further be formed on the uppermost surfaces of the first and second substrates **110** and **120**.

FIG. **12** is a plan view illustrating a first column spacer of an LCD device according to the second embodiment of the present invention.

As shown in FIG. **12**, the first column spacer **140** of the LCD device according to the second embodiment of the present invention is arranged between the gate line **131** and the common line **137**, which are more adjacent to each other than those of the first embodiment. The column spacer **140** is overlapped with the upper portion on the gate and common lines. In this case, to maintain the contact area between the second substrate **120** and the first column spacer **140** similarly to the first embodiment, the line width can be reduced so that the gate line **131** and the common line **137** below the first column spacer **140** can be more retracted.

FIG. **13** is a plan view illustrating a first column spacer of an LCD device according to the third embodiment of the present invention, and FIG. **15** is a structural sectional view taken along line V-V' of FIG. **13**.

As shown in FIG. **13** and FIG. **15**, in the LCD device according to the third embodiment of the present invention, a gate line **142** and a common line **147** are formed on a second substrate in parallel with each other. The gate line **142** and the common line **147** are respectively provided with a gate slit **142a** and a common slit **147a** to face each other. The first column spacer **140** is formed on the first substrate between the gate slit **142a** and the common slit **147a**.

At this time, the first column spacer **140** is formed on the line V-V' of FIG. **13**. That is, the first column spacer **140** is formed over the gate line **142**, the gate slit **142a**, the gate line, the common line **147**, and the common slit **147a** and the common line **147**. The first column spacer **140** may be extended to the gate slit **142a** and the common slit **147a** to overlap these slits. If the column spacer **140** is arranged as above, the gate insulating layer **125** and the passivation film **126** are formed on the second substrate to have a recessed portion. Therefore, the contact area between the first column spacer **140** and the passivation film **126** is actually reduced.

FIG. **14** is a plan view illustrating a first column spacer of an LCD device according to the fourth embodiment of the present invention, and FIG. **16** is a structural sectional view taken along line VI-VI' of FIG. **14**.

In the LCD device according to the fourth embodiment of the present invention, a slit of one line is removed from the structure of the third embodiment. As shown in FIG. **14**, only

a gate slit **151a** may be provided. Also, only a common slit may be provided. It is important that the first column spacer **140** is arranged to pass through the slit.

In the LCD device according to the fourth embodiment of the present invention, the first column spacer **140** is formed over a predetermined portion of the gate slit **151a** and the common line **157** in a structure in which the gate slit **151a** is formed at the gate line **151**. The gate line **151** and the common line **157** are formed substantially parallel with each other and face each other.

At this time, the first column spacer **140** is formed on the line VI-VI' of FIG. **14**. That is, the first column spacer **140** is formed over the gate line **151**, the gate slit **151a**, the gate line, and the common line **157**. As an example, the first column spacer **140** may be extended to the predetermined portion of the common line **151** and the gate slit **151a** to overlap them. If the column spacer **140** is arranged as above, the gate insulating layer **125** and the passivation film **126** have a recessed portion at a portion adjacent to the first column spacer **140**. Therefore, the contact area between the first column spacer **140** and the passivation film **126** is actually reduced.

In the LCD device according to the fourth embodiment of the present invention, the cell gap is maintained through the first column spacer and the touch defect can be avoided. Also, at least one slit is provided on at least one of the gate line and the common line corresponding to the first column spacer so that the first column spacer is formed to correspond to the step difference defined by the recessed portion formed by the slit. Thus, the gap is remarkably reduced by about 800 \AA in comparison with the structure in which the column spacer is formed to correspond to the extension or the TFT. As a result, it is possible to improve the touch defect and maintain a stable cell gap.

Furthermore, when the LCD panel is pressurized by the second column spacer, a certain margin is obtained to remarkably reduce deformation of the column spacer. This could lead to a stable cell gap.

FIG. **17** is a graph illustrating a liquid crystal dispensing margin in the structure of the LCD device according to the present invention.

FIG. **17** illustrates a result obtained by applying the LCD device of the present invention to a 37" LCD model. A proper liquid crystal dispensing amount that can remove the touch defect and the gravity defect is in the range of 300 dot to 306 dot. In other words, 6 dot corresponds to the normal range having neither touch defect nor gravity defect. If the liquid crystal is dispensed on the LCD panel in a range smaller than 300 dot, a large touch defect occurs. If the liquid crystal is dispensed on the LCD panel in a range greater than 306 dot, a large gravity defect occurs. In the structure in which the column spacer is formed to correspond to the extension or the TFT, the proper dispensing amount is in a range of about 0 dot to 3 dot as the touch defect is biased to the right on the graph and the gravity defect is biased to the left on the graph. In this way, since the proper dispensing amount has an increased range, it is possible to obtain a stable cell gap and remove the defect.

As described above, the LCD device according to the present invention has the following advantages.

First, since the first column spacer is arranged on the line passing through or between the gate and common lines, it is in contact with the opposing substrate to correspond to the recess defined on the above line, thereby reducing the contact area between the column spacer and the substrate and thus preventing the touch defect from occurring.

Second, the slit of either the portion between the gate line and the common line or the predetermined line is provided on

the line from the gate line to the common line so that the first column spacer is formed to correspond to the step difference defined by the recessed portion formed by the slit. Thus, the gap is remarkably reduced by about 800 Å (obtained assuming that the source and drain metal layer and the semiconductor layer have a thickness of about 2000 Å) in comparison with the structure in which the column spacer is formed to correspond to the extension of the TFT. As a result, it is possible to remove the touch defect and maintain a stable cell gap over the whole LCD panel.

Third, when the LCD panel is pressurized by the second column spacer, a certain margin is obtained to remarkably reduce deformation of the column spacer. This could lead to a stable cell gap.

Finally, the reduction of the gap and the stable cell gap obtained by reducing deformation of the column spacer serve to improve the liquid crystal dispensing margin.

It will be apparent to those skilled in the art that various modifications and variations can be made in the present invention without departing from the spirit or scope of the inventions. Thus, it is intended that the present invention covers the modifications and variations of this invention provided they come within the scope of the appended claims and their equivalents.

What is claimed is:

1. The LCD device comprising:
 - first and second substrates facing each other;
 - gate lines and data lines formed on the first substrate to cross each other, and define pixel regions;
 - a thin film transistor (TFT) formed in each portion where the gate lines cross the data lines;
 - common lines parallel to the gate lines, wherein each common line is spaced apart from each gate line at an interval of about 8 μm to 16 μm;
 - at least one common electrode extended from the common lines and at least one pixel electrode connected to a drain electrode of the thin film transistor in each of the pixel regions;
 - at least one slit in each of the common line and the gate line;
 - a plurality of first column spacers, wherein the center of each first column spacer is formed on the second substrate and overlaps with a recessed portion between the gate lines and the common lines and wherein edges of each first column spacer are overlapped with the at least one slit in the common line and the gate line; and
 - a liquid crystal layer filled between the first and second substrates.

* * * * *

专利名称(译)	具有间隔物的液晶显示装置与公共线和栅极线中的狭缝重叠		
公开(公告)号	US7557892	公开(公告)日	2009-07-07
申请号	US11/267265	申请日	2005-11-07
[标]申请(专利权)人(译)	金正日W ^ㄴ YOO WON ^ h		
申请(专利权)人(译)	金正日W ^ㄴ YOO WON ^ h		
当前申请(专利权)人(译)	LG DISPLAY CO. , LTD.		
[标]发明人	KIM JONG WOO YOO WON HYUNG		
发明人	KIM, JONG WOO YOO, WON HYUNG		
IPC分类号	G02F1/1339 G02F1/1343		
CPC分类号	G02F1/134363 G02F1/13394		
优先权	1020040116284 2004-12-30 KR		
其他公开文献	US20060146222A1		
外部链接	Espacenet USPTO		

摘要(译)

公开了一种LCD装置，其中用于单元间隙的柱状隔离物布置在栅极线和公共线之间，以减小柱状隔离物与相对基板之间的接触面积，并且通过减少a的变化来在整个面板上保持稳定的单元间隙。与柱状衬垫料对应的薄膜晶体管 (TFT) 基板的每单位面积的厚度。 LCD装置包括彼此面对的第一和第二基板，形成在第一基板上以彼此交叉的栅极线和数据线，以及像素区域，在栅极线和数据线交叉的每个部分中形成的薄膜晶体管，公共和像素电极交替地形成在像素区域中，与栅极线相邻形成的公共线基本平行于栅极线，形成在第二基板上的第一柱状间隔物对应于栅极线和公共线之间的部分，以及填充的液晶层在第一和第二基板之间。

