



US006411357B1

(12) **United States Patent**
Ting et al.

(10) **Patent No.:** **US 6,411,357 B1**
(45) **Date of Patent:** **Jun. 25, 2002**

(54) **ELECTRODE STRUCTURE FOR A WIDE VIEWING ANGLE LIQUID CRYSTAL DISPLAY**

(75) Inventors: **Dai-Liang Ting**, Hsinchu; **Lisen Chuang**, Penghu; **Ching-Chao Chang**, Taipei, all of (TW)

(73) Assignee: **Industrial Technology Research Institute**, Hsinchu (TW)

(*) Notice: Subject to any disclaimer, the term of this patent is extended or adjusted under 35 U.S.C. 154(b) by 0 days.

(21) Appl. No.: **09/483,416**

(22) Filed: **Jan. 14, 2000**

(30) **Foreign Application Priority Data**

Sep. 13, 1999 (TW) 88108187A01

(51) **Int. Cl.⁷** **G02F 1/1343**

(52) **U.S. Cl.** **349/141; 349/146**

(58) **Field of Search** **349/141, 143, 349/123, 146**

(56) **References Cited**

U.S. PATENT DOCUMENTS

5,745,207 A * 4/1998 Asada et al. 349/141

6,288,763 B1 * 9/2001 Hirota 349/141

* cited by examiner

Primary Examiner—William L. Sikes

Assistant Examiner—Dung Nguyen

(57) **ABSTRACT**

An electrode structure for a liquid crystal display includes a layer of pixel electrodes each having a herringbone-shaped structure, a passivation layer and a layer of common electrodes. The pixel electrodes are formed in parallel above the common electrodes. The herringbone-shaped structure of a pixel electrode has a predefined turning angle between 45 degrees to 90 degrees. The pixel electrode structure allows the liquid crystals in the display to rotate in two directions, clockwise and counterclockwise, to compensate for the color dispersion caused by a wide viewing angle.

8 Claims, 4 Drawing Sheets

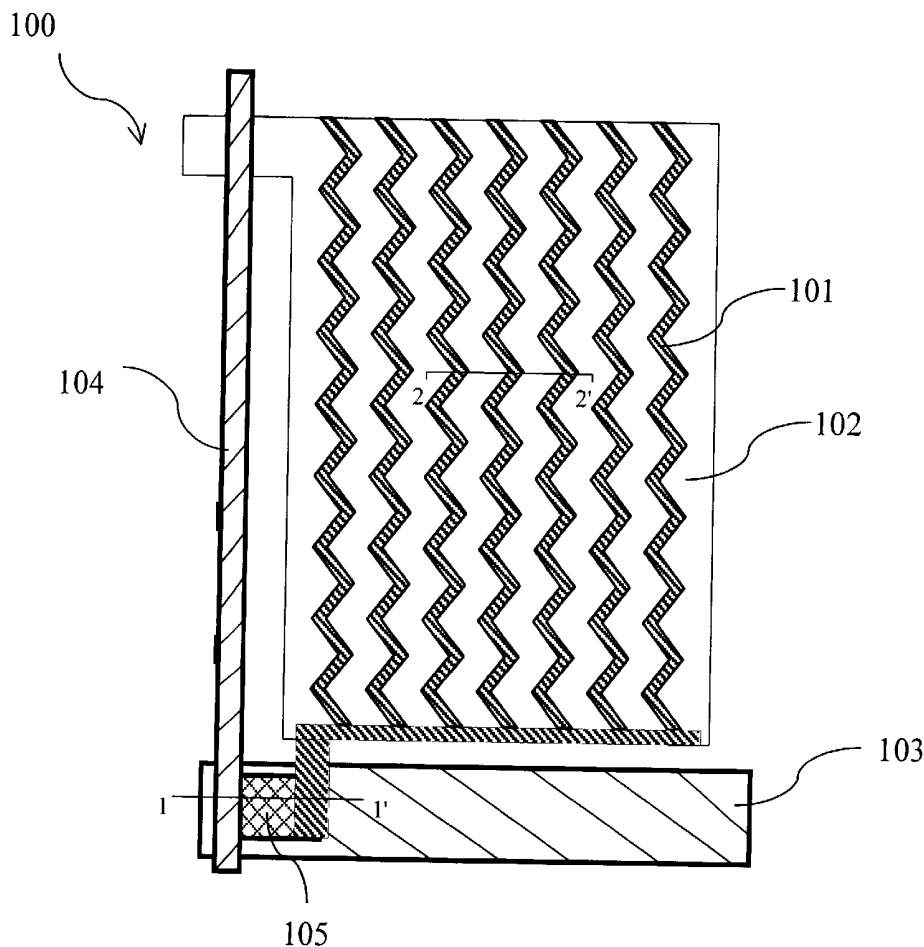

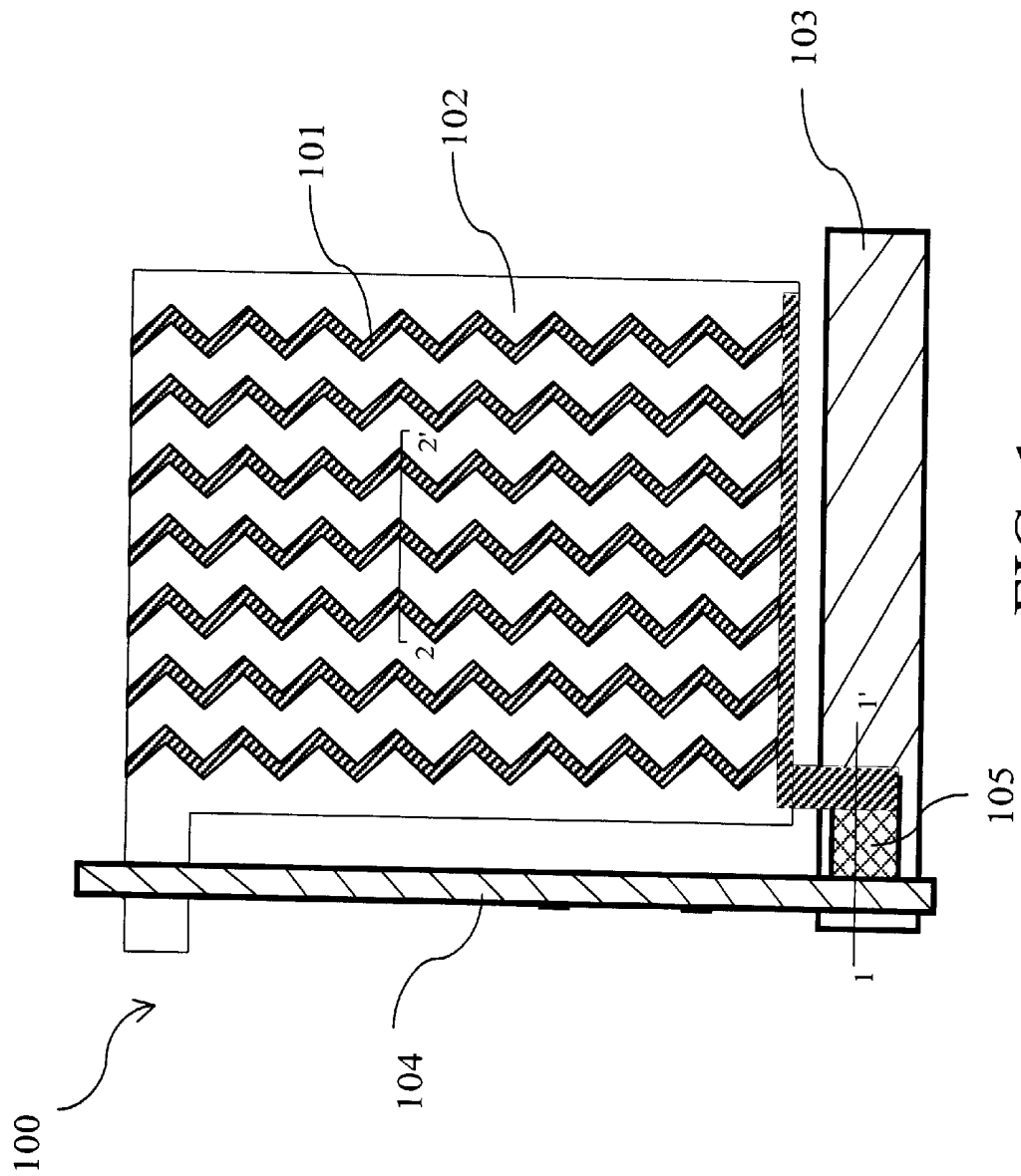

FIG. 1

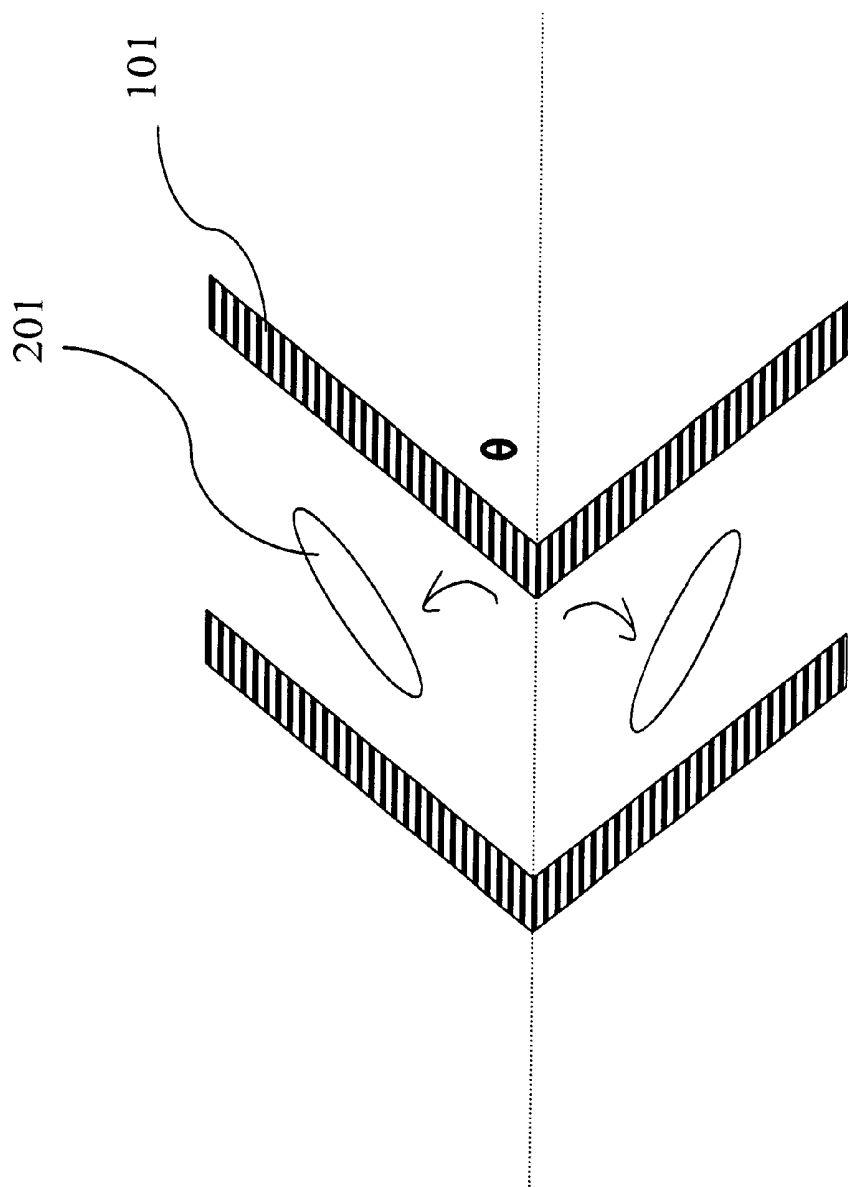

FIG. 2

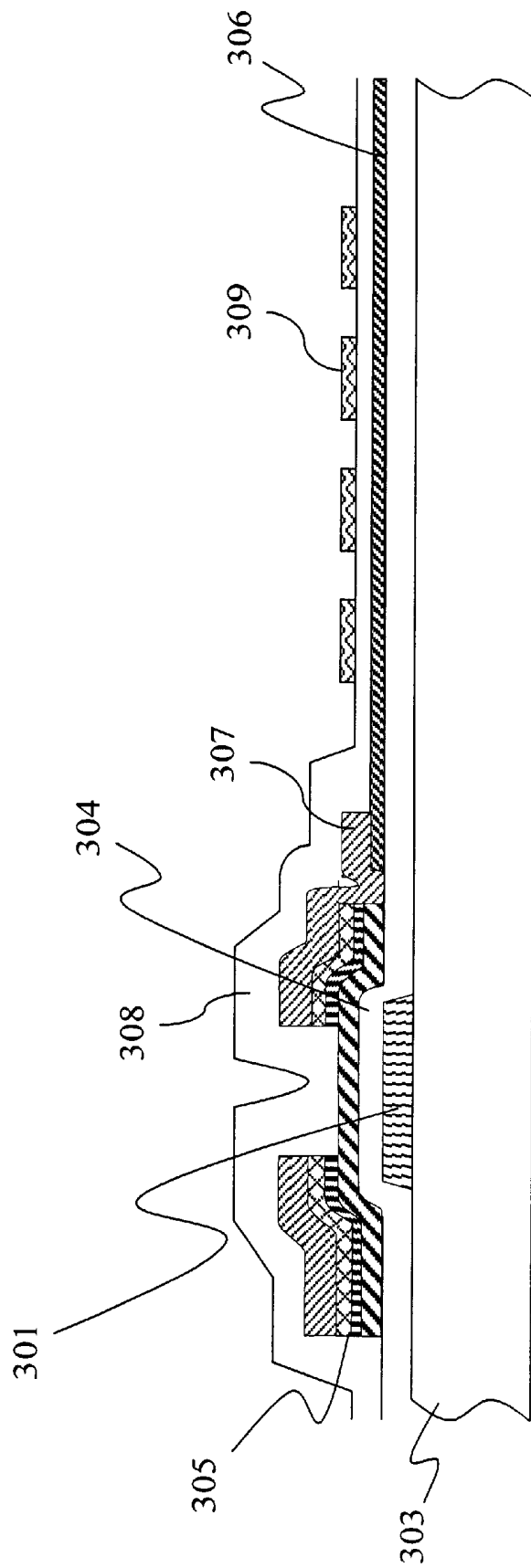

FIG. 3

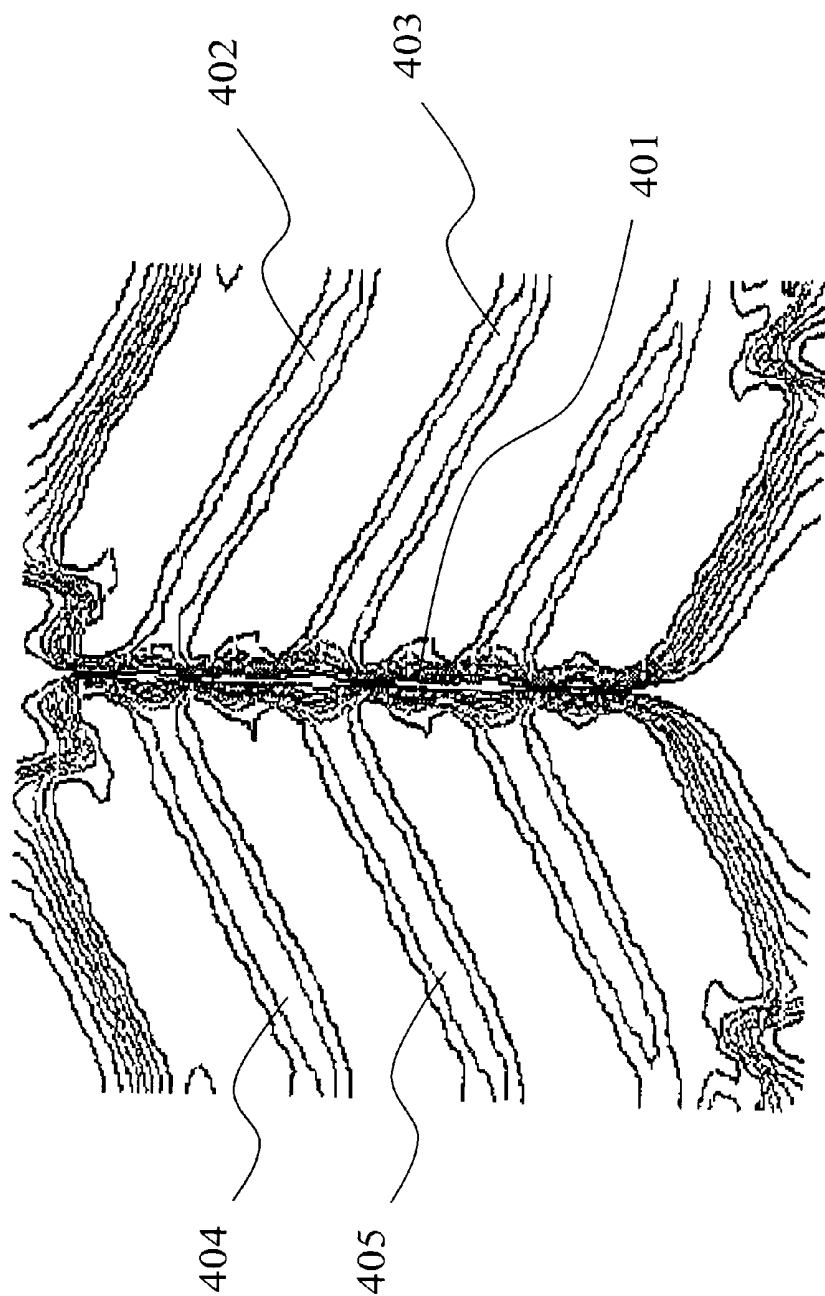

FIG. 4

ELECTRODE STRUCTURE FOR A WIDE VIEWING ANGLE LIQUID CRYSTAL DISPLAY

FIELD OF THE INVENTION

The present invention relates generally to an electrode structure of a liquid crystal display, and more particularly to an electrode structure of a wide viewing angle liquid crystal display.

BACKGROUND OF THE INVENTION

A large number of liquid crystal display (LCD) panels have recently been employed as display devices in electronic products. The technologies of wide viewing angle liquid crystal displays have been disclosed very often in recent years. In a Taiwan patent application No. 88108187 entitled "Electrode Structure of A Wide Viewing Angle Liquid Crystal Display", an electrode structure for providing wide viewing angle is disclosed. The electrode structure comprises an upper electrode layer having multiple comb-shaped and parallel conductors on a glass substrate, a lower electrode layer having a TN-type conductor and a layer of non-conductive insulator formed between the upper and lower electrode layers.

In the embodiment of the Taiwan patent application, the pixel electrodes in the upper layer of the electrode structure has a comb-shaped structure while the common electrode in the lower layer has a plate-shaped structure. A layer of negative-type liquid crystal is used to fill the space between the upper and lower glass substrates of the LCD. The two electrode layers are fabricated on the lower glass substrate.

The drawback of the electrode structure disclosed in the Taiwan patent application is that the liquid crystal driven by an electric voltage rotates toward one direction. Therefore, the effect of color dispersion at different viewing angle limits the viewing angle of the LCD and degrades the quality of the display.

SUMMARY OF THE INVENTION

The present invention has been made to overcome the above-mentioned drawback of the electrode structure in the prior art. The primary object of the invention is to provide an electrode structure for a wide viewing angle liquid crystal display. The electrode structure has upper and lower electrode layers. The pixel electrode in the upper layer has a herringbone-shaped structure while the common electrode in the lower layer has a plate-shaped structure.

The liquid crystal display has two separated glass substrates between which liquid crystals are filled. Multiple scan signal lines, multiple data signal lines, multiple switching elements, and a layer of common electrodes are fabricated on the surface of the lower glass substrate. The scan signal lines are perpendicular to the data signal lines in order to form a pixel matrix. A passivation layer made of a transparent non-conductive insulator is formed between the layer of pixel electrodes and the layer of common electrodes.

The herringbone-shaped structure of the pixel electrodes allows the liquid crystal molecules to rotate in two directions, clockwise and counterclockwise. The color dispersion caused by a wide viewing angle is thus compensated for. The herringbone-shaped structure also helps to maintain the brightness of pixels.

The foregoing and other objects, features, aspects and advantages of the present invention will become better understood from a careful reading of a detailed description

provided herein below with appropriate reference to the accompanying drawings.

BRIEF DESCRIPTION OF THE DRAWINGS

FIG. 1 is a top view showing the electrode structure of a single pixel for a wide viewing angle liquid crystal display according to the preferred embodiment of the present invention.

FIG. 2 shows the liquid crystal rotates in two opposite directions according to the electrode structure of the present invention.

FIG. 3 shows the cross section along line 1-1' and line 2-2' of FIG. 1.

FIG. 4 illustrates the brightness distribution in a single pixel of the electrode structure of the present invention when an electric voltage is applied.

DETAILED DESCRIPTION OF THE PREFERRED EMBODIMENTS

FIG. 1 is a top view showing the electrode structure **100** of a single pixel for a wide viewing angle liquid crystal display according to the preferred embodiment of the present invention. Referring to FIG. 1, the upper layer of the electrode structure **100** comprises a plurality of pixel electrodes **101** each having a herringbone-shaped structure while the lower layer comprises a common electrode **102** having a plate-shaped structure. The scan signal line region **103** is perpendicular to the data signal line region **104** to form a pixel.

As shown in FIG. 1, a thin film transistor **105** used as a switching device is located near the crossing point of the scan signal line region **103** and the data signal line region **104** in a single pixel. The scan signal line region **103** and the data signal line region **104** are adjacent to the area where the pixel electrodes **101** are formed.

The thin film transistor is an active switching device that controls the charging and discharging of the pixel electrodes. In addition to the thin film transistor, the active switching device may also be a Metal Oxide Semiconductor (MOS) transistor, a diode, a Metal-Insulator-Metal (MIM) transistor or a variable resistor according to the invention.

The following illustrates in detail the electrode structure of a wide viewing angle liquid crystal display of the present invention. The electrode structure including a common electrode layer, a pixel electrode layer, and a passivation layer is formed above a glass substrate. On the top surface of the glass substrate, there are multiple scan signal lines, multiple data signal lines, multiple switching elements, and a layer of common electrodes. The passivation layer is made of a transparent non-conductive insulator and located between the common electrode layer and the pixel electrode layer. The passivation layer can be formed by depositing or growing an insulator film on the thin film transistor.

For every single pixel, the data signal line is located above and perpendicular to the scan signal line. At least a switching element such as a thin film transistor **105** is fabricated near the crossing point of the scan signal line and the data signal line. The gate terminal of the switching element connects to the scan signal line, the drain terminal connects to the data signal line and the source terminal connects to the pixel electrode.

As mentioned above, the pixel electrode has a herringbone-shaped structure. Pixel electrodes are formed in parallel. The turning angle θ shown in FIG. 2 in the herringbone-shaped structure is within a pre-defined range,

about 45 to 90 degrees. The herringbone-shaped structure of the pixel electrodes allows the liquid crystal molecules **201** to rotate in two directions, clockwise and counterclockwise. As shown in FIG. 2, the liquid crystal molecules **201** rotates in both clockwise and counterclockwise directions by a θ angle. The color dispersion-caused by a viewing angle is thus compensated for and the effect of color dispersion is reduced.

The herringbone-shaped structure of the pixel electrodes maintains the brightness above the pixel electrodes in the certain range of θ . The intensity is proportional to the square of $\sin 2\theta$, therefore, if the turning angle θ is less than 45 degrees, the maximal value of θ is also less than 45 degrees. The pixel brightness will not reach its maximum value.

According to the invention, the electrode pitch in the layer of pixel electrodes is about 1 to 15 μm and the electrode width is about 1 to 10 μm . In the structure of a single pixel, the herringbone-shaped pixel electrodes **101** and the common electrode **102** both keep a distance from the scan signal line region **103** and the data signal line. region **104**. They do not cross over the scan signal line region **103** and the data signal line region **104**.

FIG. 3 shows the cross section along line 1-1' and line 2-2' of FIG. 1. Along line 1-1' of FIG. 1 is the steps of fabricating the thin film transistor, the data line and the scan line. Along line 2-2' is the steps of fabricating the pixel electrodes **101** and the common electrode **102**.

Referring to FIG. 3, the cross section along line 1-1' of FIG. 1 illustrates in detail every layer of the structure above the substrate. A metallic layer of the scan signal line **301** is first formed above the glass substrate **303**. Then, the glass substrate **303** is covered with an insulator layer **304** and an island-like region **305** is formed to provide an active layer for the thin film transistor. The thin film transistor comprises at least a gate, a drain, and a source. The gate terminal of the thin film transistor connects to the scan signal line **301**, the drain terminal connects to the data signal line **307** and the source terminal connects to the pixel electrodes **306**.

The present invention forms a layer of plate-shaped common electrodes **306**. The plate-shaped common electrodes **306** can be made of transparent or non-transparent conductive materials. The general transparent conductive materials may be indium-tin-oxide (ITO), SnO_2 , N type amorphous silicon film, N type poly-silicon film, P type poly-silicon film, and ZnO, etc. Non-transparent conductive material may be other metallic material. The plate-shaped common electrodes **306** do not cross over the island-like region **305**, as shown in FIG. 3.

Above the island-like region **305** is a metallic layer of data signal lines **307**. A passivation layer **308** is further used to cover the substrate. Similarly, the electric contact with the data signal line metallic layer **307** can be established by forming multiple contact holes outside the pixel region.

Along line 2-2' of FIG. 1 is the steps of forming the layer of pixel electrodes. A layer of herringbone-shaped pixel electrodes **309** is fabricated above the layer of common electrodes **306** and the passivation layer **308**. The herringbone-shaped pixel electrodes **309** can be made of transparent or non-transparent conductive materials.

As mentioned above, the structure of the herringbone-shaped pixel electrodes preserves the brightness of pixels.

FIG. 4 illustrates the distribution of brightness in a single pixel of the electrode structure of the present invention when an electric voltage is applied. The brightness at the middle portion **401** of the herringbone-shaped pixel electrode is almost zero. However, more than 70% effective transmission of light can be achieved at regions **402**, **403**, **404**, and **405** that are parallel to each other.

Although this invention has been described with a certain degree of particularity, it is to be understood that the present disclosure has been made by way of preferred embodiments only and that numerous changes in the detailed structure and combination as well as arrangement of parts may be restored to without departing from the spirit and scope of the invention as hereinafter set forth.

What is claimed is:

1. An electrode structure of a wide viewing angle liquid crystal display comprising:

a scan signal line;

a data signal line perpendicular to said scan signal line, said scan signal line and said data signal line defining a pixel area;

a common electrode in said pixel area;

a passivation layer above said common electrode; and a plurality of pixel electrodes each having a herringbone-shaped structure and running substantially in parallel with said data signal line above said passivation layer and said common electrode;

wherein said common electrode has a plate-shaped structure substantially filling said pixel area below said plurality of pixel electrodes.

2. The electrode structure of a wide viewing angle liquid crystal display as claimed in claim 1, said herringbone-shaped structure having a turning angle ranging from 45 degrees to 90 degrees.

3. The electrode structure of a wide viewing angle liquid crystal display as claimed in claim 1, said plurality of pixel electrodes having a pitch ranging from 1 to 15 μm and the width of each pixel electrode ranging from 1 to 10 μm .

4. The electrode structure of a wide viewing angle liquid crystal display as claimed in claim 1, wherein said common electrode is made of indium-tin-oxide, SnO_2 , N-type amorphous silicon film, N type poly-silicon film, P type poly-silicon film, or ZnO.

5. The electrode structure of a wide viewing angle liquid crystal display as claimed in claim 1, wherein said pixel electrodes are made of indium-tin-oxide, SnO_2 , N-type amorphous silicon film, N type poly-silicon film, P type poly-silicon film, or ZnO.

6. The electrode structure of a wide viewing angle liquid crystal display as claimed in claim 1, wherein said pixel electrodes are made of metal material.

7. The electrode structure of a wide viewing angle liquid crystal display as claimed in claim 1, further comprising a switching device.

8. The electrode structure of a wide viewing angle liquid crystal display as claimed in claim 7, said switching device being a thin film transistor.

* * * * *



US006411357C1

(12) **INTER PARTES REEXAMINATION CERTIFICATE** (871st)

United States Patent

Ting et al.

(10) **Number:** **US 6,411,357 C1**

(45) **Certificate Issued:** **May 8, 2014**

(54) **ELECTRODE STRUCTURE FOR A WIDE VIEWING ANGLE LIQUID CRYSTAL DISPLAY**

(75) **Inventors:** **Dai-Liang Ting**, Hsinchu (TW); **Lisen Chuang**, Penghu (TW); **Ching-Chao Chang**, Taipei (TW)

(73) **Assignee:** **Industrial Technology Research Institute**, Chutung, Hsinchu (TW)

Reexamination Request:

No. 95/002,133, Sep. 4, 2012

Reexamination Certificate for:

Patent No.: **6,411,357**
Issued: **Jun. 25, 2002**
Appl. No.: **09/483,416**
Filed: **Jan. 14, 2000**

(30) **Foreign Application Priority Data**

Sep. 13, 1999 (TW) 88108187 A

(51) **Int. Cl.**

G02F 1/1343 (2006.01)

(52) **U.S. Cl.**
USPC **349/141; 349/146**

(58) **Field of Classification Search**
None
See application file for complete search history.

(56) **References Cited**

To view the complete listing of prior art documents cited during the proceeding for Reexamination Control Number 95/002,133, please refer to the USPTO's public Patent Application Information Retrieval (PAIR) system under the Display References tab.

Primary Examiner — Minh Nguyen

(57) **ABSTRACT**

An electrode structure for a liquid crystal display includes a layer of pixel electrodes each having a herringbone-shaped structure, a passivation layer and a layer of common electrodes. The pixel electrodes are formed in parallel above the common electrodes. The herringbone-shaped structure of a pixel electrode has a predefined turning angle between 45 degrees to 90 degrees. The pixel electrode structure allows the liquid crystals in the display to rotate in two directions, clockwise and counterclockwise, to compensate for the color dispersion caused by a wide viewing angle.

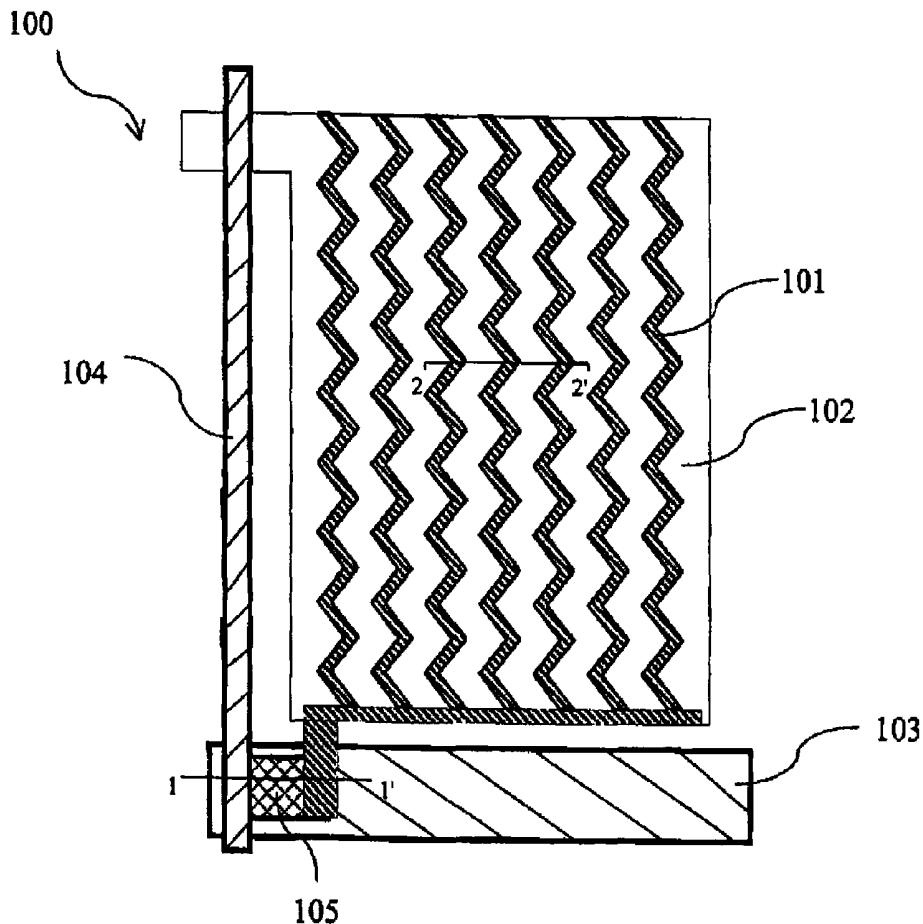

**INTER PARTES
REEXAMINATION CERTIFICATE
ISSUED UNDER 35 U.S.C. 316**

5

THE PATENT IS HEREBY AMENDED AS
INDICATED BELOW.

AS A RESULT OF REEXAMINATION, IT HAS BEEN
DETERMINED THAT:

10

Claims 1, 7 and 8 are cancelled.

Claims 2-6 were not reexamined.

* * * * *

专利名称(译)	用于宽视角液晶显示器的电极结构		
公开(公告)号	US6411357	公开(公告)日	2002-06-25
申请号	US09/483416	申请日	2000-01-14
[标]申请(专利权)人(译)	财团法人工业技术研究院		
申请(专利权)人(译)	工业技术研究院		
当前申请(专利权)人(译)	工业技术研究院		
[标]发明人	TING DAI LIANG CHUANG LISEN CHANG CHING CHAO		
发明人	TING, DAI-LIANG CHUANG, LISEN CHANG, CHING-CHAO		
IPC分类号	G02F1/13 G02F1/1343 G02F1/136 G02F1/1368 G09F9/30		
CPC分类号	G02F1/134363		
助理审查员(译)	NGUYEN, 粪便		
优先权	088108187A01 1999-09-13 TW		
外部链接	Espacenet USPTO		

摘要(译)

用于液晶显示器的电极结构包括一层像素电极，每个像素电极具有人字形结构，钝化层和公共电极层。像素电极在公共电极上方平行形成。像素电极的人字形结构具有45度至90度之间的预定转角。像素电极结构允许显示器中的液晶沿顺时针和逆时针两个方向旋转，以补偿由宽视角引起的色散。

